

ENGINE-EPA CERTIFIED

Model Komatsu S3D84E-3B
 Type Water cooled, 4-stroke cycle
 Aspiration Turbocharged
 Number of cylinders 3
 Bore x stroke 84 mm x 90 mm **3.31" x 3.54"**
 Piston displacement 1.5 ltr. **91 cu. in.**
 Governor Mechanical
 Horsepower rating @ 2500 rpm
 Flywheel horsepower 27.2 kw **37 HP**
 Meets EPA emissions regulations

Fuel system Direct injection
 Lubrication system
 Method Gear pump, force lubrication
 Filter Full-flow
 Air cleaner Dry type with double elements
 & dust evacuator, plus dust indicator

TRANSMISSION

Drive Method Hydrostatic

Travel Speed*	Forward		Reverse	
	15.0 km/h	9.3 mph	15.0 km/h	9.3 mph

*Measured with 15.5/70-18 tires

AXLES AND FINAL DRIVES

Drive system Four wheel drive
 Front Fixed, semi-floating
 Rear Center-pin support
 semi-floating, 16° total oscillation
 Reduction gear Spiral bevel gear
 Final reduction gear Planetary gear, single reduction
 Oscillating Angle ± 16°

BRAKES

Service brake Hydraulically-activated, wet, sealed disc
 Parking brake Mechanically-activated, wet, sealed disc
 Tire size 12.5/70-16-6PR

STEERING SYSTEM

Type Full hydraulic power, center pivot steering
 Steering angle 40°
 Minimum turning radius at the
 center of outside tire 3210 mm **10'6"**

BOOM AND BUCKET

Z-bar loader linkage is designed for maximum rigidity and offers powerful breakout. Rap-out loader linkage design enables shock dumping for removing sticky materials.

BUCKET CONTROLS

Control positions

Boom Raise, hold, lower & float
 Bucket Roll back, hold & dump

HYDRAULIC SYSTEM

Capacity (discharge flow) @ engine-rated rpm

Loader pump 43 ltr/min **11.4 US gal/min**
 Auxiliary hydraulic 43 ltr/min **11.4 US gal/min**
 (Gear-type pumps)

Relief valve setting

Loader 210 bar **2990 psi**

Control valve

3-spool, open center type

Hydraulic cylinders

Loader and steering Double-acting, piston

Hydraulic Cylinders	Number of Cylinders	Bore		Stroke	
		Boom	2	75 mm	2.95"
Bucket	1	75 mm	2.95"	360 mm	14.2"

Hydraulic cycle time (rated load in bucket)

Raise 4.6 sec
 Dump 1.0 sec
 Lower (empty) 2.8 sec
 Rollback 1.4 sec
 Total cycle time 9.8 sec

SERVICE REFILL CAPACITIES

Cooling System 5.8 ltr. **1.5 US gal.**
 Fuel Tank 42.0 ltr. **11.9 US gal.**
 Engine 4.7 ltr. **1.24 US gal.**
 Hydraulic reservoir 28.0 ltr. **7.4 US gal.**
 Axle (each, front and rear) 9.3 ltr. **1.4 US gal.**

Standard Equipment

- Alarm, back-up
- Canopy, ROPS
- Directional signals
- Engine coolant temp. gauge
- Fuel gauge
- Head lights (two)
- Horn
- Hourmeter
- Hydraulic oil temp. gauge
- Rearview mirrors (two)
- Seat, adjustable
- Seat belt (3 in.)
- Tachometer
- Indicator Lights, for: battery, parking brake, engine pre-heat, engine oil pressure, hydraulic filter restriction

Optional Equipment

- Auxiliary hydraulics
- Mechanical front attachment coupler
- 66" Bucket
- 48" Pallet forks

Dimensions

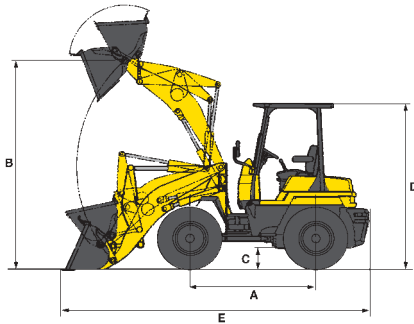

Standard tires	15.5/70-18-8PR	
Tread (Front and rear)	1250 mm	4'1"
Width over tires	1655 mm	5'5"
A Wheelbase	1850 mm	6'1"
B Hinge pin height, maximum height	3115 mm	10'3"
C Ground clearance	310 mm	12"
D Overall height, ROPS canopy	2500 mm	8'2"
E Overall length	4550 mm	14'11"

Bucket		Pin-on Bucket with Bolt-on Cutting Edge		Attachment Coupler with Bolt-on Cutting Edge		Attachment Coupler with 48" pallet forks	
Bucket capacity	SAE rated	0.6 m ³	.75 yd ³	.6 m ³	.75 yd ³	N/A	N/A
Bucket width		1690 mm	5'7"	1665 mm	5'6"	N/A	N/A
Bucket weight (48" Pallet fork weight)		215 kg	473 lb	250 kg	550 lb	(172 kg)	(378 lb)
Static tipping load	Straight	2550 kg	5,830 lb	2412 kg	5,306 lb	1807 kg	3,975 lb
	Full turn (40°)	2306 kg	5,073 lb	2098 kg	4,615 lb	1572 kg	3,450 lb
Operating capacity - 50% of full turn tipping load		1153 kg	2,536 lb	1049 kg	2,307 lb	788 kg	1,729 lb
Dump clearance, maximum height and 45° dump angle		2140 mm	7'0"	2140 mm	7'0"	N/A	N/A
Reach at maximum height and 45° dump angle		785 mm	2'7"	785 mm	2'7"	N/A	N/A
Operating height	Fully raised	3375 mm	11'1"	3375 mm	11'1"	N/A	N/A
Turning radius*		3610 mm	11'10"	N/A	N/A	N/A	N/A
Digging depth	10°	150 mm	5.9"	150 mm	5.9"	N/A	N/A
Breakout force		3050 kg	6,720 lb	3050 kg	6,720 lb	N/A	N/A
Operating weight		3720 kg	8,200 lb	3791 kg	8,340 lb	3705 kg	8,150 lb

• All dimensions, weights, and performance values based on SAE J732c and J742b standards. Static tipping load and operating weight shown include 15.5/70-18PR tires, lubricant, coolant, full fuel tank, ROPS canopy, and operator. Machine stability and operating weight are affected by counterweight, tire size, and other attachments.

N/A - Not applicable

* Turning radius measured with bucket at carry position, outside corner of bucket.

This specification sheet may contain attachments and optional equipment that are not available in your area. Please contact your local Komatsu Utility Corporation distributor for those items you may require. Materials and specifications are subject to change without notice.

Form No. KUSS114-01

© 2001 Komatsu Printed in USA PLI (7.5M) PL

Printed in USA 0601

KOMATSU®

PO Box 8112 • Vernon Hills, IL 60061-8112
website: www.komatsuutility.com

