

TCM[®]

OPERATION & MAINTENANCE MANUAL

WHEEL LOADER

L3-2

L4-2

L5-2

L6-2



It is the responsibility of the Operator & Supervisor to read and understand this manual.

Protect the earth and be kind to loader.

TCM CORPORATION

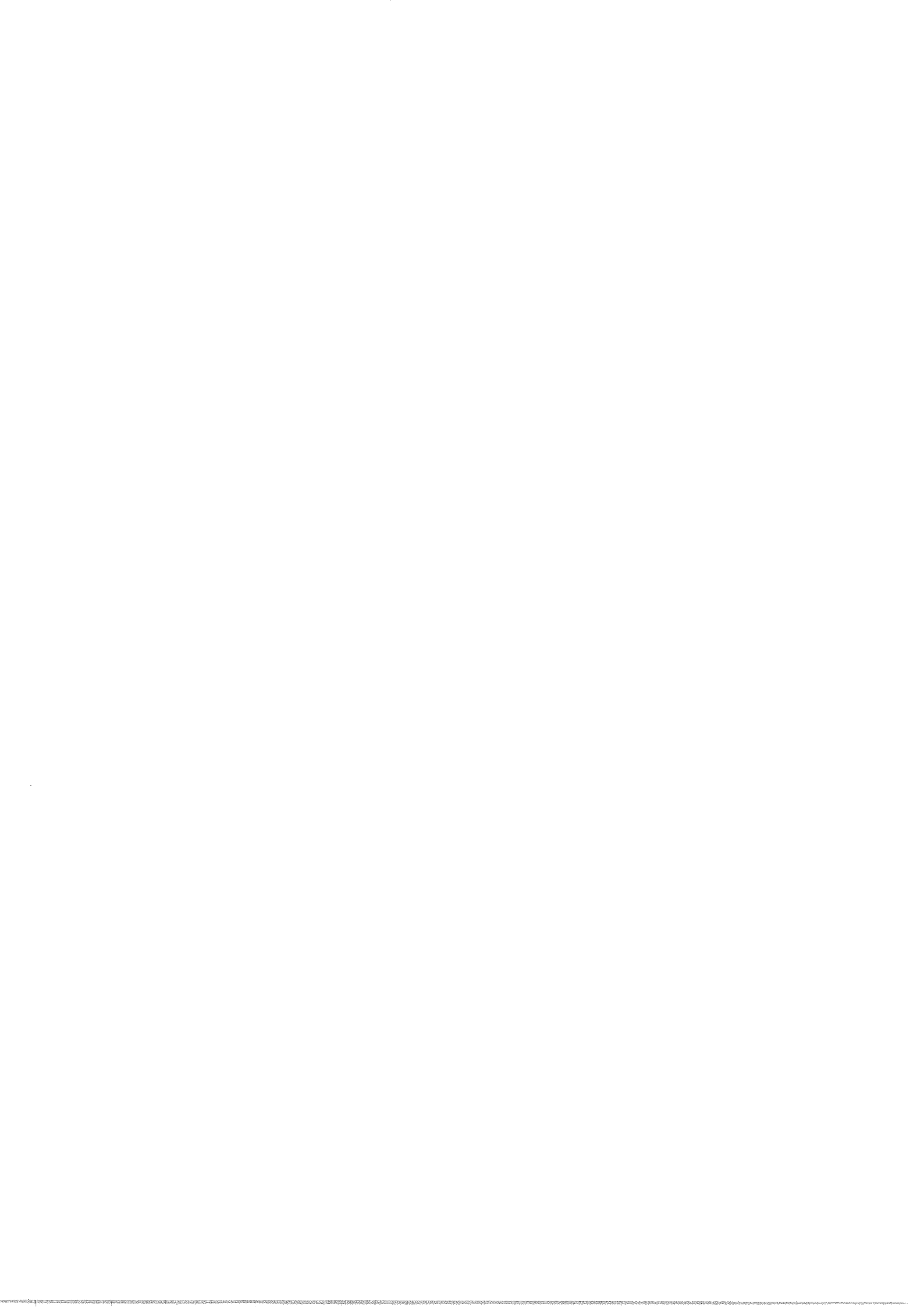

Introduction

Read this manual carefully to learn how to operate and service your machine correctly. Failure to do so can cause in personal injury or equipment damage.

This manual is part of your machine and should remain with machine when you sell your machine. Replace this manual when damaged. Contact your TCM dealer or TCM to obtain replacement of this manual.

This manual contains "SAFETY", "OPERATION" and "MAINTANANCE".
"SAFETY" explain basic precautions for safety in operation and maintenance.
"OPERATION" explain basic machine operation.
"MAINTENANCE" explain lubrication, inspection and maintenance of machine.

Right-hand and Left-hand sides are determined by facing in direction of forward travel.

When using machine with optional equipment, read separate manual for respective optional equipment.

WARNING

Careless operation of machine may result in accident leading to injury or death.

Read this manual carefully to learn how to operate and service your machine.

Keep this manual near machine at all times, and have people who operate machine read manual repeatedly.

When this manual is lost or damaged, replace it.

If you sell machine, be sure to remain this manual with machine.

CONTENTS

Safety Signs	0-1
1. Safety	0-2
2. Direction of Machine	0-2
3. Break-in	0-3
4. Precautions with Respect to Attachments	0-3
5. California Proposition 65 Warning	0-3
6. Safety Signs	0-4
Failure Notice	0-8

SAFETY

Introduction	1-1
--------------------	-----

Safety Operation

1. Basic Understanding	1-2
2. Prepare for Safe Operation	1-7
3. Before Starting Engine	1-10
4. After Starting Engine	1-13
5. Safety Operation	1-14
6. Snow Condition	1-29
7. After Operation	1-30
8. Transporting	1-32
9. Towing	1-34

Safety Maintenance

1. Basic Understanding	1-35
2. Before Maintenance	1-37
3. Maintenance	1-38
4. After Maintenance	1-46

OPERATION

Names of Components	2-1
Operator's Station	2-2
Cab Operation	2-25
Engine Operation	2-31
Operating Machine	2-36
Operating Procedures	2-43
Servicing Batteries	2-49
Operation in Cold Weather	2-53
Tire Maintenance	2-55
Seat Belt	2-58
Transporting	2-59
Long-Term Storage	2-66

CONTENTS

MAINTENANCE

Maintenance	3-1
Periodical Replacement of Safety Parts	3-5
Fuel, Water and Lubricants Selection and Capacities	3-10
Maintenance Chart	3-14
Periodical Maintenance/Daily	3-16
Periodical Maintenance/100 Hours or 1 Months	3-27
Periodical Maintenance/250 Hours or 3 Months	3-30
Periodical Maintenance/500 Hours or 6	3-36
Periodical Maintenance/1000 Hours or 12	3-40
Maintenance/When Required	3-51
Adjustment of Each Part	3-60
Troubleshooting	3-62
Specifications	3-65
Main Equipment	3-69
Write Down Your Loader Data Here	3-70
Maintenance Log	3-71
Notes	3-75

Safety Signs

Most accidents during machine operation are attributable to negligence of basic safety rules and warnings. Such accidents can be avoided by exercising sufficient care in advance.

Wrong operation, lubrication, or maintenance may cause an accident leading to injury or death. Carefully read and thoroughly understand safety precautions and warning explained in this manual before operating, lubricating, or maintaining machine.

Safety signs are affixed to machine to prevent accidents that lead to personal injury or death. Carefully read and completely understand preventive methods and cautions written on Safety signs. When Safety signs have come off or when they are damaged, replace with new ones.

Safety messages on safety signs in this manual and on machine are classified as follows.

 DANGER
DANGER indicates imminently hazardous situation which, if not avoided, will result in death or serious injury.

 WARNING
WARNING indicates potentially hazardous situation which, if not avoided, could result in death or serious injury.

 CAUTION
CAUTION indicates potentially hazardous situation which, if not avoided, may result in minor or moderate injury.

IMPORTANT
Negligence of safety message may damage machine or shorten its service life.

 marks are shown on pictures that depict dangerous work procedures or situations.

Pictures are used to direct attention to text, not representing all details of text. Safety signs shown in manual or affixed to machine do not explain all conceivable precautions.

1. Safety

Keep safety in mind at all times during operation and maintenance, and pay the closest attention.

Basic safety precautions are summarized in “SAFETY” at beginning of this manual.

Observe precautions with  mark in text in order to ensure safety, because they are especially important for safety.

Use this machine primarily for operations specified below.

(See “Operation Procedures”.)

- Leveling the ground
- Loading
- Excavating

Precautions with respect to operation, inspection, maintenance, and safety shown in this manual are related only to the operation of machine for specified works. When using machine for purposes other than those specified in this manual, ensure safety by yourself.

2. Direction of Machine

Front, rear, right, and left shown in this manual are those when viewed from operator’s seat.

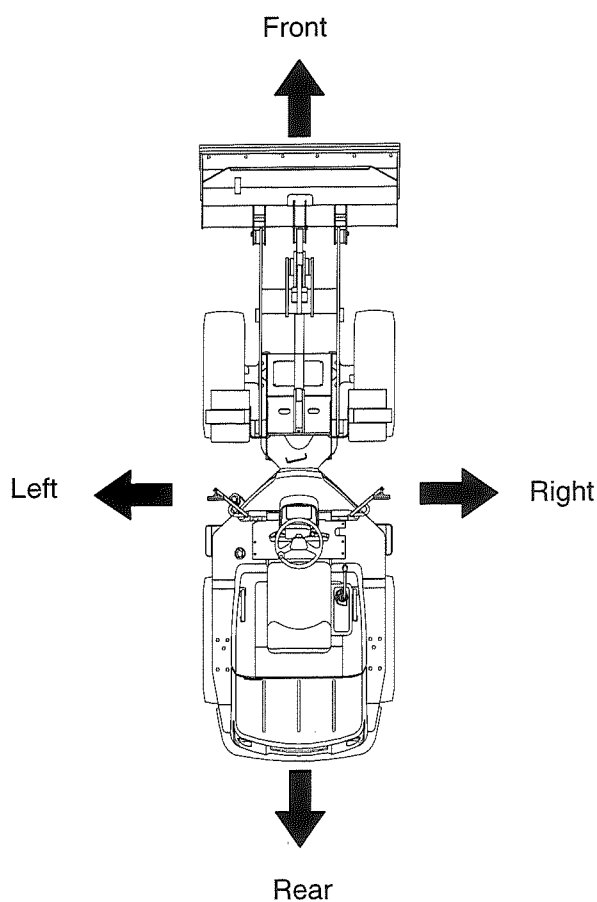

3. Break-in

New machines are sufficiently inspected before shipment. Rough operation in break-in period will hasten deterioration of performance. Avoid rough operation while first 100 hours (indicated by hour meter).

Break in machine while paying attention to following:

- Warm-up engine for 5 minutes after starting.
- Avoid high-speed operation or operation under heavy load.
- Avoid abrupt starting and acceleration or unnecessary sudden stopping and turning.

4. Precautions With Respect to Attachments

When operating machine equipped with optional attachments, read instruction manual for respective attachments.

Do not use attachments that are not approved by your authorized dealer. Use of unapproved attachments will not only pose safety problems but exercise adverse effects on operation and life of machine.

We will not take responsibility for accidents that led to injury, death, or damage to machine due to use of unapproved attachments.

5. California Proposition 65 Warning

Diesel engine exhaust and some of its constituents are known to State of California to cause cancer, birth defects and other reproductive harm.

6. Safety Signs

Keep safety signs in good conditions. Replace missing or damaged safety signs with new ones. Order new safety signs from the authorized dealer, using the number at the bottom on the sign. Adhere a safety sign in the same place as before.

There are others in addition to the following safety signs. Treat them in the same way as those shown below.

0020

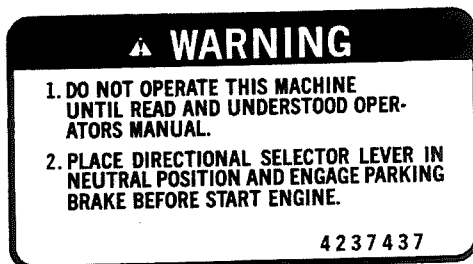

METER PANEL, RH

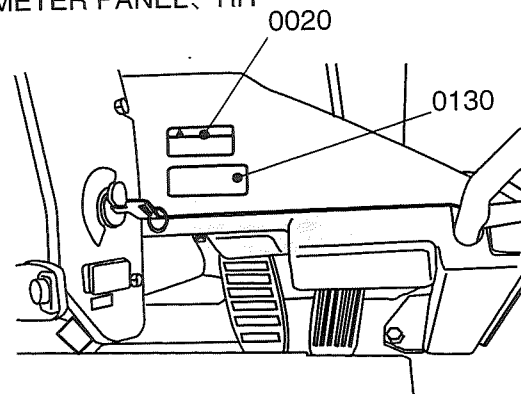

0130

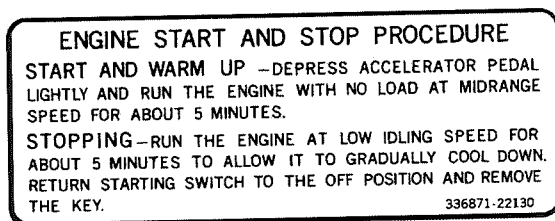

0140

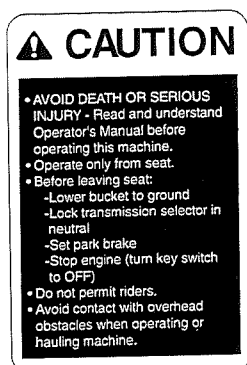

METER PANEL, RH

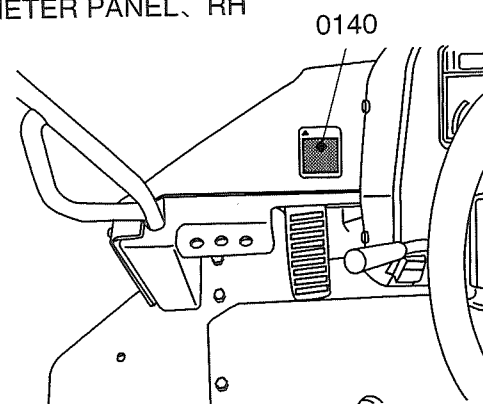

0030

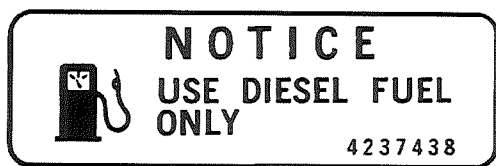

FUEL TANK

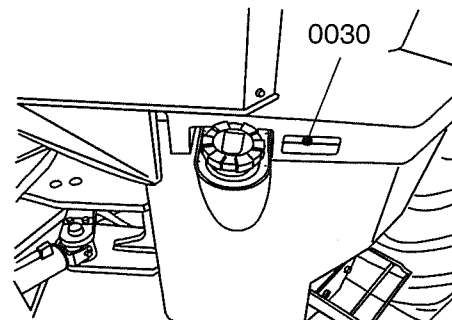

0040



OIL TANK

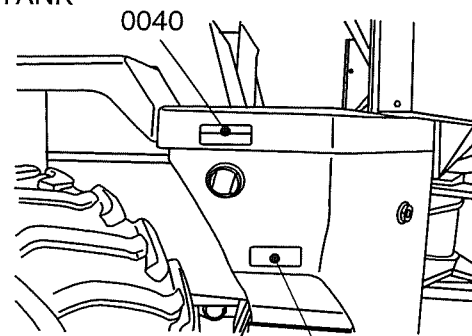

0160



0160

0050

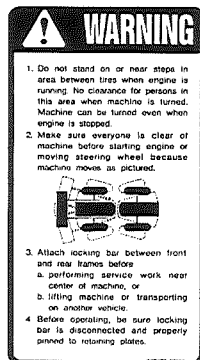

FRONT FENDER

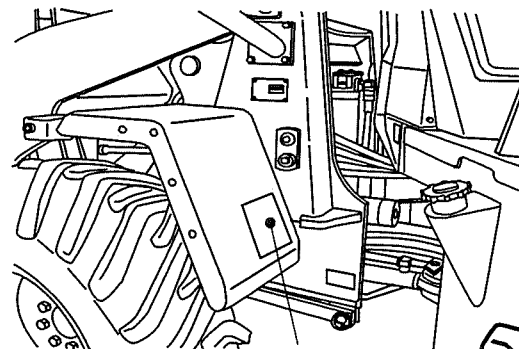

0050

0100



FRONT FRAME

0100

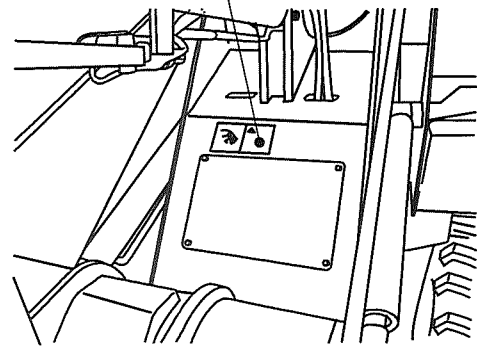

0070

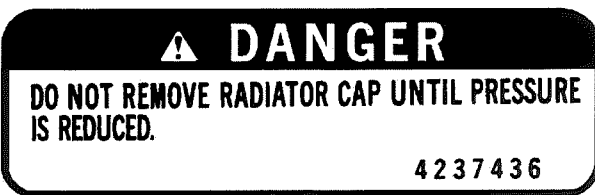

ENGINE ROOM

0070

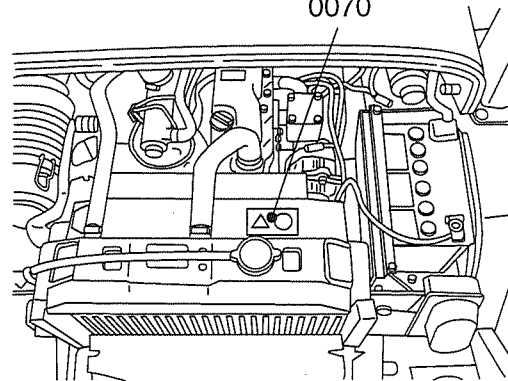

0120

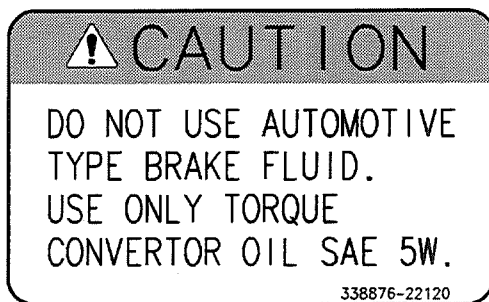

METER PANEL, UNDER

0120

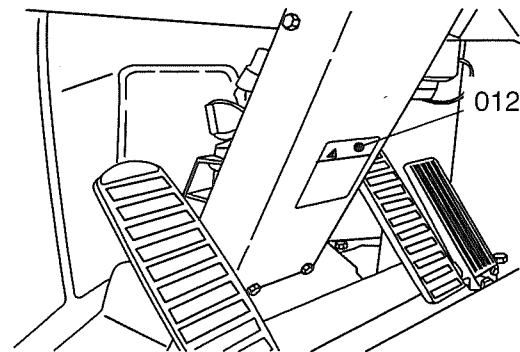

0150

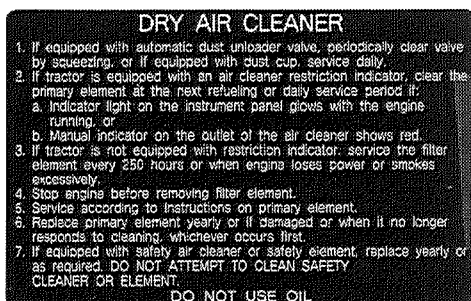

ENGINE ROOM



0150

0080

DANGER EXPLOSIVE GASES
 Cigarettes, flames or sparks could cause battery to explode. Always shield eyes and face from battery. Do not charge or use booster cables or adjust post connections without proper instruction and training.
KEEP VENT CAPS TIGHT AND LEVEL
POISON CAUSES SEVERE BURNS
 Contains sulfuric acid. Avoid contact with skin, eyes or clothing. In event of accident flush with water and call a physician immediately.
KEEP OUT OF REACH OF CHILDREN

ENGINE ROOM

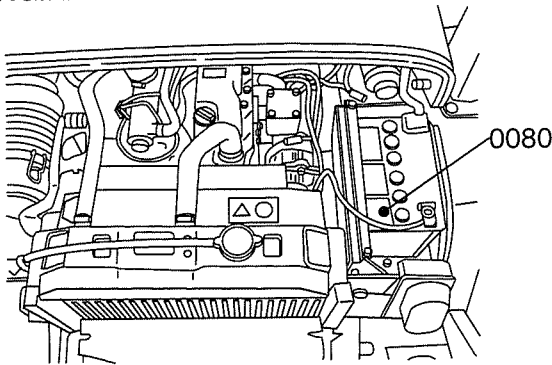

1100

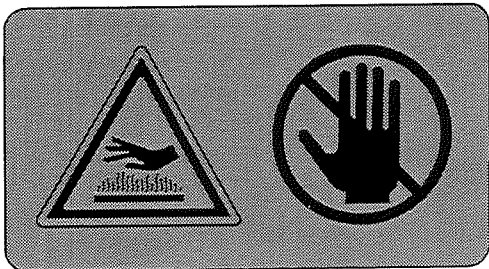

ENGINE ROOM

(L5-2/L6-2)

1100

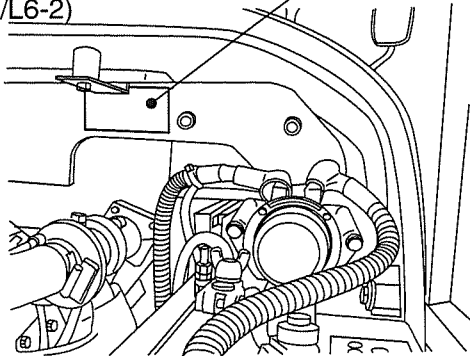

0060

NOTICE
 USE RECOMMENDED AXLE OIL ONLY
 (REFER TO OPERATOR'S MANUAL)
 4237444

AXLE, FRONT

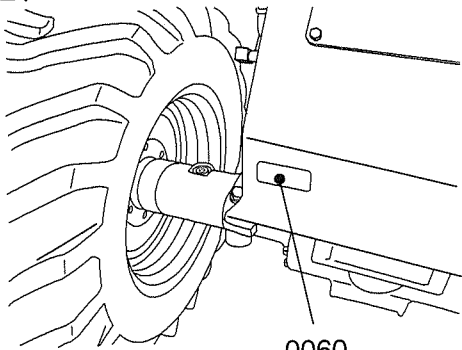

0060

Failure Notice

Inform your authorized dealer of machine No., engine No., and hour indicated by hour meter when placing orders for parts and notifying failure.

Machine No. and engine No. are shown on the service warranty.

Refer to "Meter Panel" for the hour meter.

Machine number is inscribed on the company name plate and machine body.

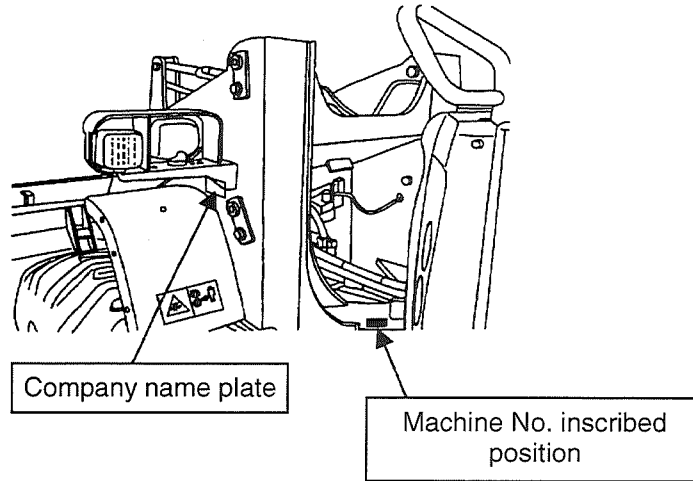

Machine No.

Model	Company name plate (Serial No.)	Inscription on machine body
L3-2	* HFK F35P0○○○○○○ * * HFK4E000C000○○○○○○ * Note 1	F35-○○○○○○
L4-2	* HFK F36P0○○○○○○ * * HFK4E100K000○○○○○○ * Note 2	F36-○○○○○○
L5-2	* HFK F37P0○○○○○○ * * HFK4E200L000○○○○○○ * Note 3	F37-○○○○○○
L6-2	* HFK F37P0○○○○○○ * * HFK4E300L000○○○○○○ * Note 3	F37-○○○○○○

Serial number

Note 1: 01049 and after Note 2: 01129 and after Note 3: 01145 and after

■ Engine No. Inscribed Position

- L3-2

D1105-○○○○○○

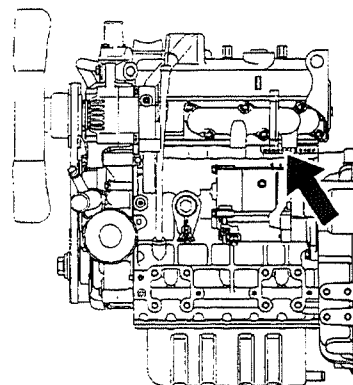

- L4-2

D1503-○○○○○○

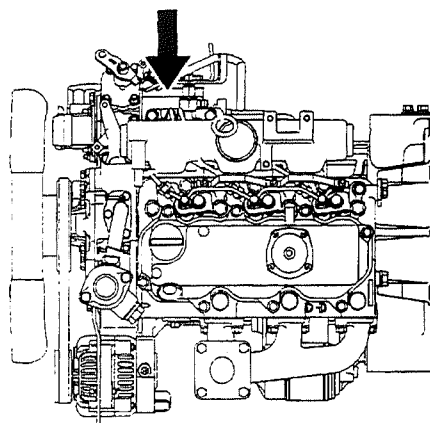

- L5-2/L6-2

D1503-○○○○○○

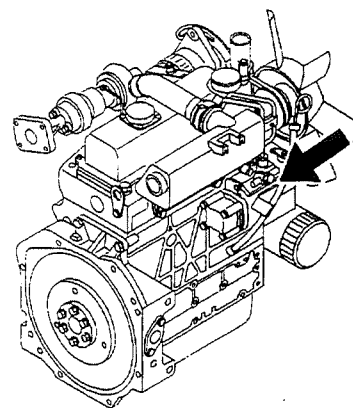

SAFETY

**WARNING**

Carefully read and observe all safety precautions, otherwise serious injury or death will result.

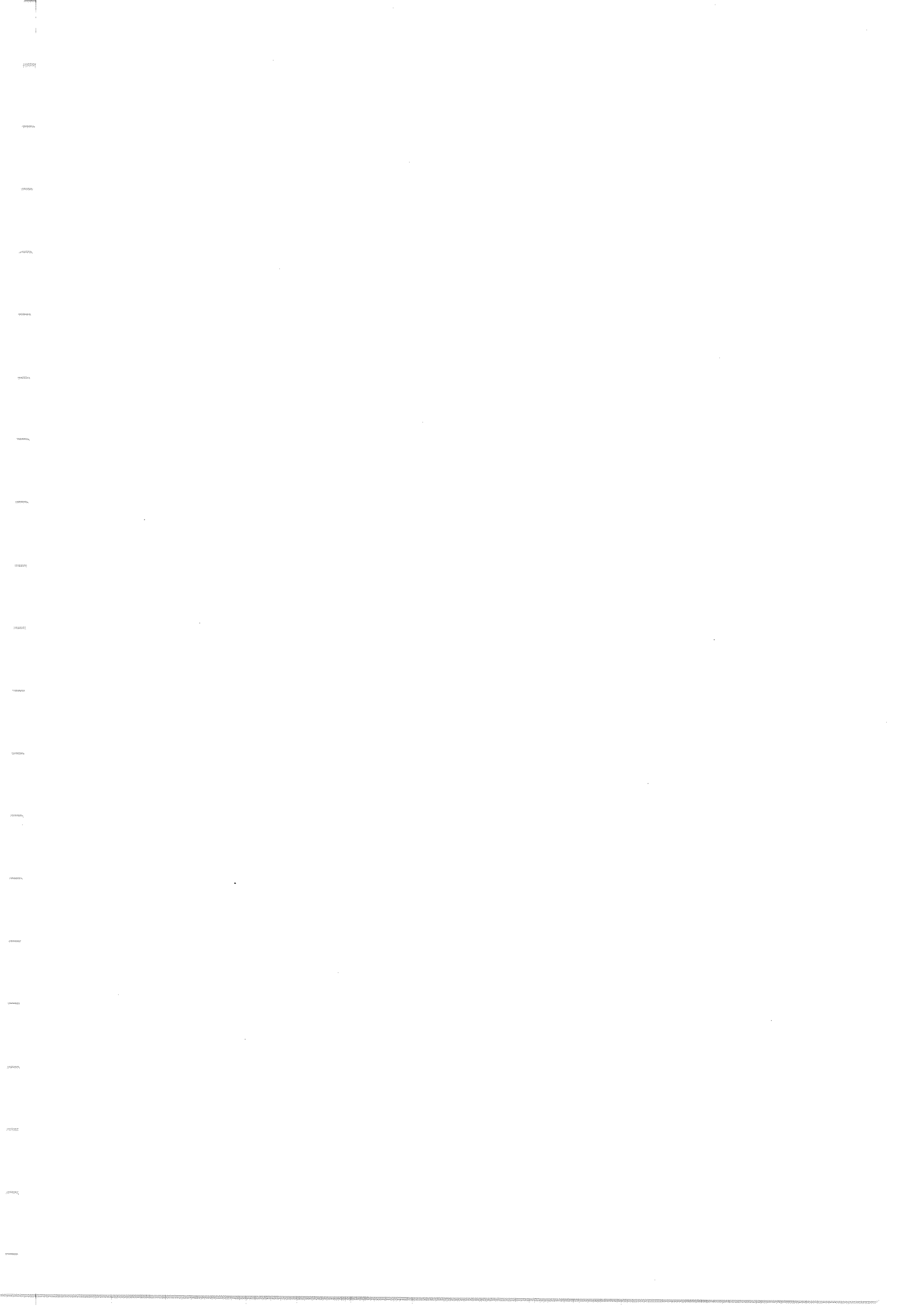

Introduction

This chapter summarizes basic points to notice concerning wheel loader operation and its inspection and maintenance procedure. This chapter illustrates specific examples you may encounter in your daily work so that you will have ample knowledge of danger and safety. You should understand purpose of operation and have knowledge about precautions regarding operational procedures, dangerous places in work area, etc. Therefore, you should examine above matters together with a supervisor and CO-workers to ensure safety operation. Key to safety operation is your responsibility. Please read this chapter carefully in order to thoroughly understand basic precautions to prevent accident resulting in injury or death.

Safety Operation

1. Basic Understanding

■ Operating Qualification

Allow only authorized and qualified persons to operate this machine.



■ Read and Understand Operating Manual

Do not operate this machine until you read and understand instructions in Operation & Maintenance Manual.

Learn how to operate machine and how to use controls properly.



■ Follow Safety Instructions

Carefully read all safety messages in this manual and on your machine safety signs. Keep safety signs in good condition. Replace missing or damaged safety signs. Be sure new equipment components and repair parts include current safety signs. Replacement safety signs are available from your authorized dealer.

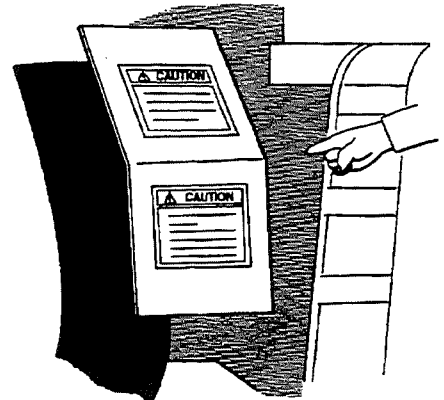

■ Overwork and Drunk Operating Prohibited

You should condition yourself for operating machine properly.

Avoid overworks, liquors, drugs and any medication which causes drowsiness.



■ **Do not Wear Loose-Fitting Clothing**

Do not wear loose-fitting clothing, any accessory and neckties which are apt to become caught on or entangled in equipment.

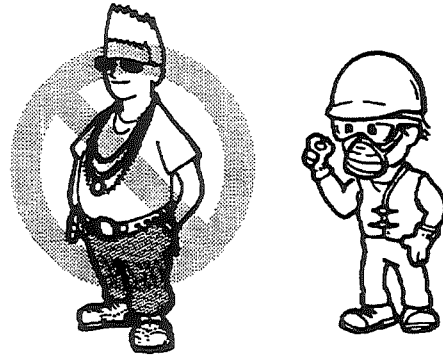

■ **Wear Protective Clothing**

Wear hard hat, safety glasses, safety shoes, working gloves and other safety equipment, as required by job conditions.

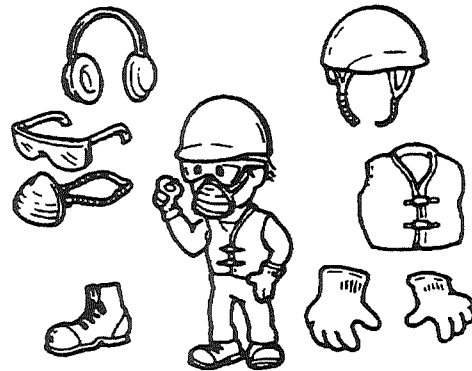

■ **Prepare Safeguard Equipment**

Prepare first aid kit and fire extinguisher for emergencies.

- Know how to use first aid kit and fire extinguisher.
- Check location of first aid and fire extinguisher.
- Keep emergency numbers for doctor, ambulance service, hospital and fire department near your phone.

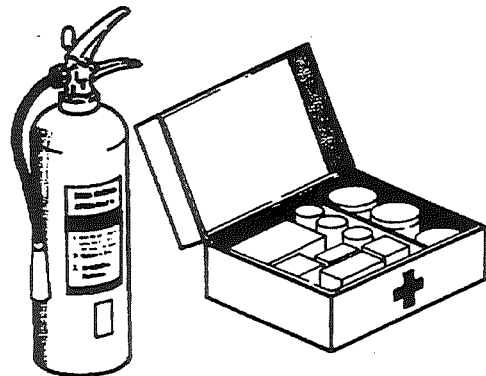

■ **Learn Thoroughly “Rules”**

Learn thoroughly “Rules” that should be observed at work site. It is responsibility of operator to know what specific requirements, precautions and work area hazards exist, and to discuss these with his foreman or supervisor.

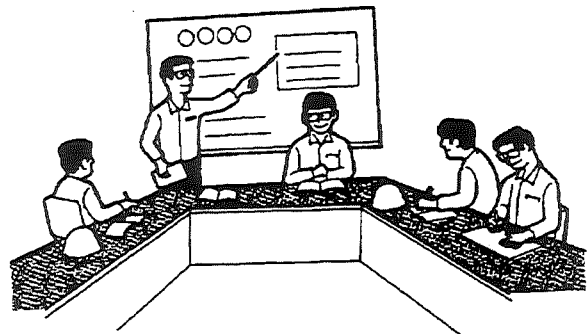

■ Learn Hand Signals

Learn hand signals to be used on job.

Do not begin operation until signals are clearly understood.

Prior to starting operation, discuss thoroughly with your signal person and determine working position and signal system.

Fix firmly in your memory meaning of all flags, signs and markings so that you understand them at glance under any circumstances.



■ Set Up Correct Work Plan

Fully understand performances of machine and operate machine in manner suitable for field.

Do not exceed performances of machine.

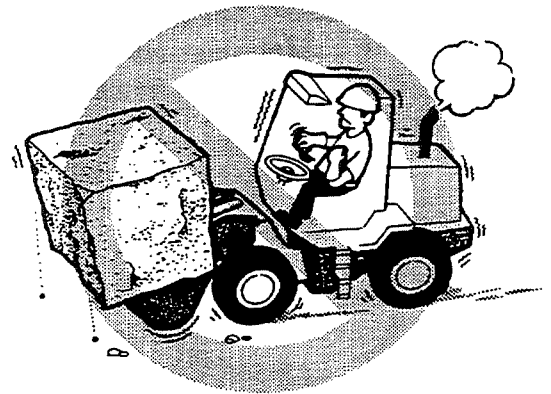

■ Check Condition of Work Site

Prior to starting operation, check conditions of ground configuration and geological features of work site and approach roads. Install safety facilities to places where machine may roll over or cave-ins may occur and do not enter dangerous area.

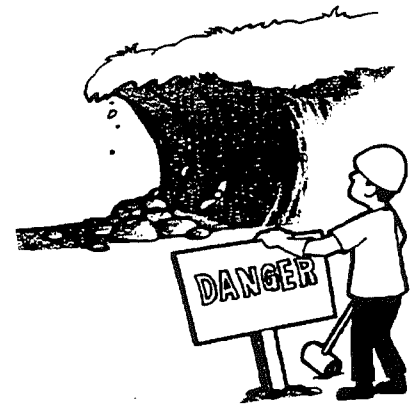

■ Inspection Machine Daily

Inspect your machine carefully each day before you start it.

Do not operate machine until corrective measures have been cleared by qualified personnel.

(See "Periodic Maintenance/Daily".)

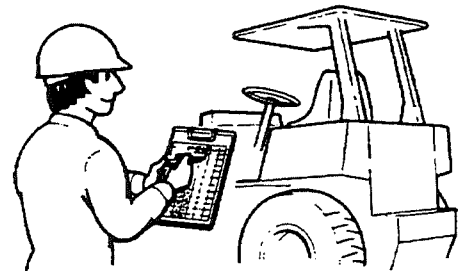

■ Use Handrails and Steps for Getting On and Off Machine

You must wait until machine fully stops before getting off. It is dangerous to get off when machine is moving even immediately before stopping. Never jump on or off.

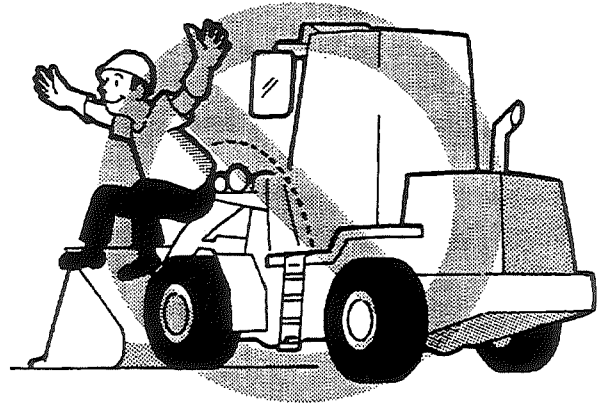

When you get off machine, always maintain three point contact with steps and handrails and face machine.

Be careful of slippery conditions on platforms, steps, handrails and on ground when leaving machine.



■ To Prevent Rolling, Always Make Sure Machine is Properly Secured Before Leaving Operator's Seat

- Select level surface when possible to park machine.
- Move Speed Shift to NEUTRAL.
- Apply parking brake.
- Lower bucket to ground.
- Stop engine.
- Move hydraulic control levers to relieve pressure.
- Set all control levers to hold position and apply each lever lock.
- Remove starting switch key so that prevent unauthorized starting or moving machine.
- Firmly place chocks against tires to prevent rolling, especially if parked on slope.
- Install all vandalism protection locks and covers.



■ Diesel Engine Exhaust

IMPORTANT

CALIFORNIA

Proposition 65 Warning

Diesel engine exhaust and some of its constituents are known to State of California to cause cancer, birth defects, and other reproductive harm.

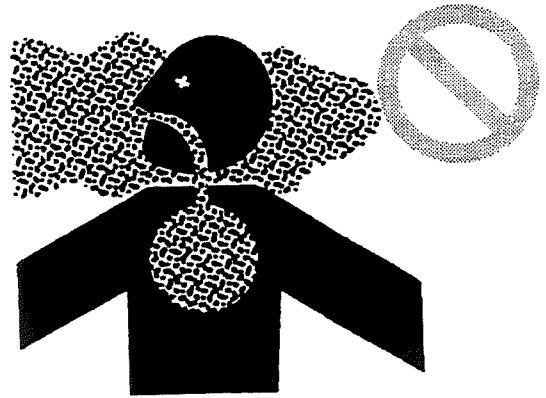

■ Remodeling Prohibited

When remodeling is necessary, contact your authorized dealer. Accident resulting in injury or death and failure of product due to remodeling without our permission are out of scope of our responsibility.

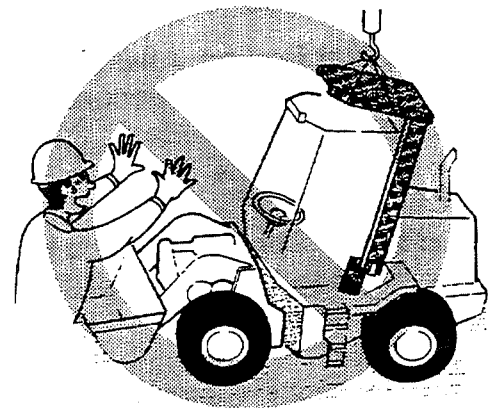

■ Caution of HEAD GUARD and ROPS

In field where stones may fall, install HEAD GUARD. Further, in field where machine may turn sideways, use Roll Over Protective Structure (ROPS) and seat belt.

Make certain all parts are reinstalled correctly if ROPS is loosened or removed for any reason. Tighten mounting bolts to specifications. Protection offered by ROPS will be impaired if ROPS is subjected to structural damage, is involved in turn over incident, or is in any way altered by welding, bending, drifting, or cutting. Damaged ROPS should be replaced, not reused. If you repair, contact your authorized dealer in advance.



2. Prepare for Safe Operation

■ Be Careful of Buried Matters (Water Lines, Gas Lines, etc.)

Before working in vicinity of gas lines or water lines; always contact owners of gas lines or water lines before beginning work.

Determine jointly what specific precautions must be taken to insure safety.

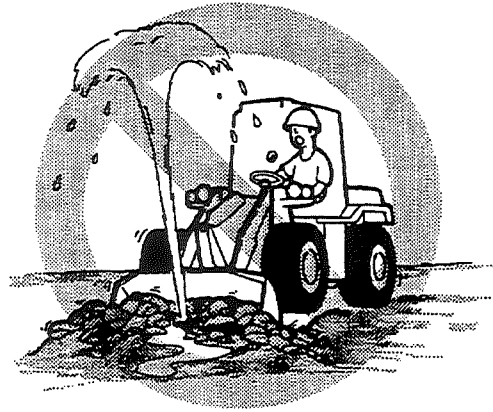

■ Off Limits to Work Site

Check that there is no people other than signal person or obstacles within work area before operation. Post "OFF LIMITS" signboard to prevent trespassing.

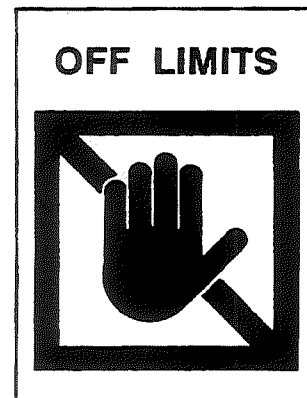

■ Observe Allowable Water Depth

When operating machine in water or fording streams, know water depth, ground condition and velocity of water in advance.

Do not take machine in water exceeding allowable depth.

(See "Allowable Water Depth".)

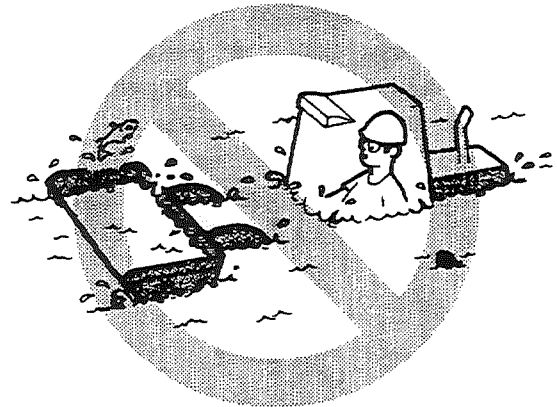

■ Use Apply Lever Locks

When you get on and off machine from right-hand side, take care not to touch control levers. Control levers could be accidentally moved and cause damage or accident.



■ **Keep Clean Engine Area**

Inspect inside of engine room and remove any dead leaves or paper waste.
Dead leaves or papers are highly inflammable and can cause fires.

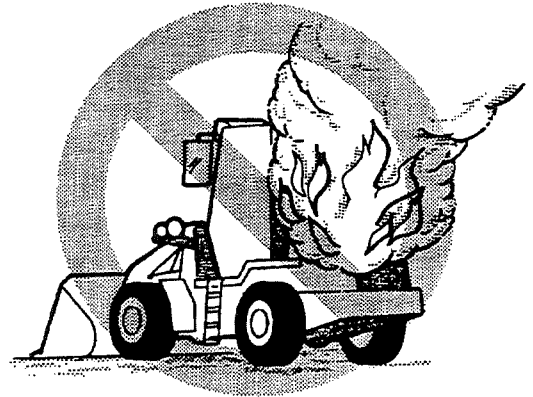

■ **Inspection of Oil, Fuel, and Water Leakage**

Check ground on which machine was parked for leakage of oil, fuel, or water. If leakage is found, repair leaking section and wipe off dirt.

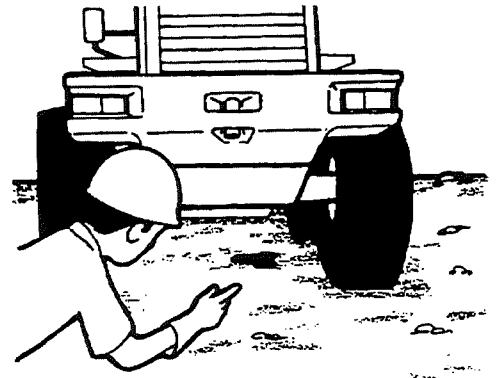

■ **How to Use Fire Extinguisher**

There exists possibility of fire always.
You must be fully aware of extinguisher to use and its location and use method always.
When you have used fire extinguisher, replace it with new one or charge fire-extinguishing agent.



■ **Park in Safe Place**

Park machine in safe place or specified place. Do not park machine in place where there are flammable objects, such as, fuel, lubricants, paper and dry grass.

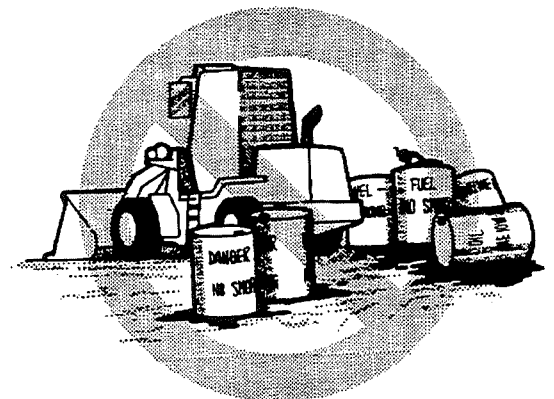

■ Keep Clean Operator Compartments

Keep operator area floor free of trash, mud or loose objects.

When tools and parts are scattered, they may jam controls.

Do not get on your machine or operate it with wet or greasy hands or slippery shoes.

Wipe off thoroughly any grease, oil or mud on floor, steps, handrail, control levers or pedals. Also, keep shoe soles free of oil as this causes slipping, resulting in accident.

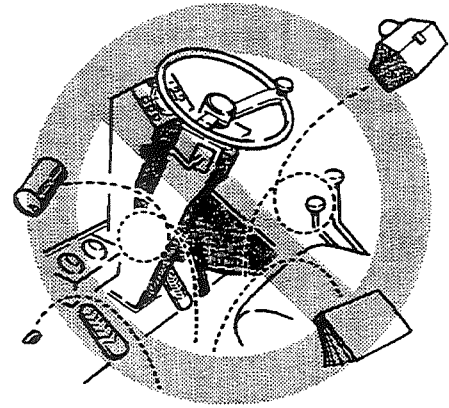

■ Read and Obey Safety Signs

Keep safety signs in good condition. Replace missing or damaged safety signs.

Safety signs attached to machine provide precautions for using machine.



■ Check Safety Equipment

Check safety devices equipped on machine before starting engine to ensure correct operation of machine.

- Check all safety guards and covers are mounted correctly. Repair breakage or tighten loose or fallen bolts, if any.
- Check all safety guards and covers are mounted correctly. Repair breakage or tighten loose or fallen bolts, if any.
- Check all lever locks are in position and functioning properly.
- Do not remove safety devices.

(See "Walk-Around Inspection".)



3. Before Starting Engine

■ Safety Check of Around machine

Make sure no person is working under machine or in invisible place from operator's seat before starting engine or starts to move machine.

Warn people when machine starts to move.

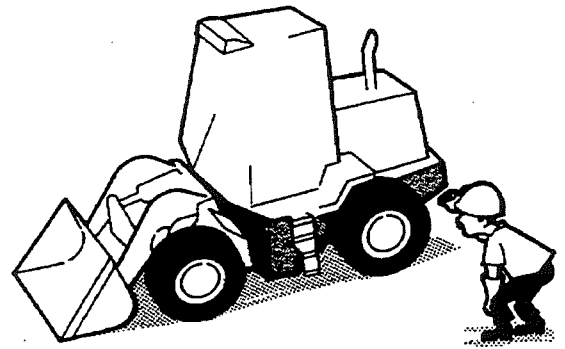

■ Be Careful of "CAUTION" Tag

If "CAUTION" tag is attached to door, control lever or steering wheel, do not start engine or do not move control levers.



■ Good Visibility

Clean windshield, windows and mirrors before you start, to provide good visibility.

Secure windows and doors in either open or shut position.



■ Good Rear Visibility

Adjust sideview mirrors and room mirror for proper rear view.

If mirror is broken, replace it.

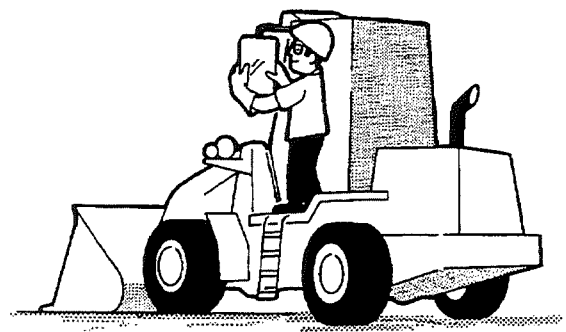

■ **Check Steering Frame Locking Bar**

Check steering frame locking bar is in carry position. Locked machine cannot be steered.

(See "Safety Bar".)

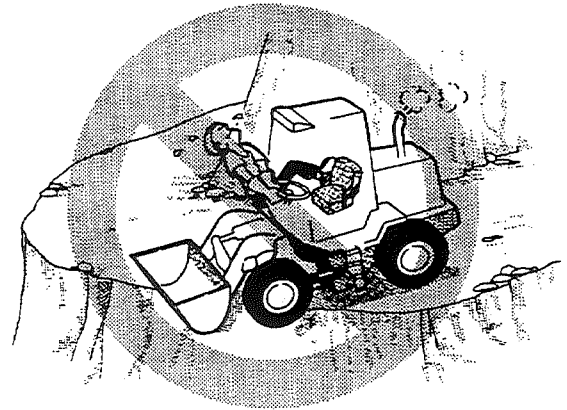

■ **Are Lights and Horn Functioning?**

Operate light switch all lights and lights in instruments for correct lighting, as well as for dirt and damage to check. Check that horn and back buzzer, sound correctly.

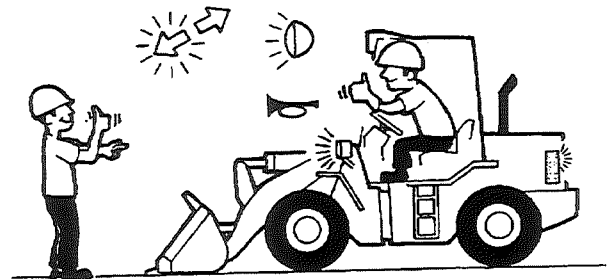

■ **Adjust Seat for Easy Operation**

Adjust seat so that full brake pedal travel can be obtained with operator's back against seat back.

When moving machine backward, you are apt to take an attitude of twisting body so as to keep watching backward. Then, adjust position of seat so as to be able to securely depress brake pedal.

Do not adjust operator's seat while machine is moving: seat could move suddenly, causing loss of control.

(See "Operator's Seat".)

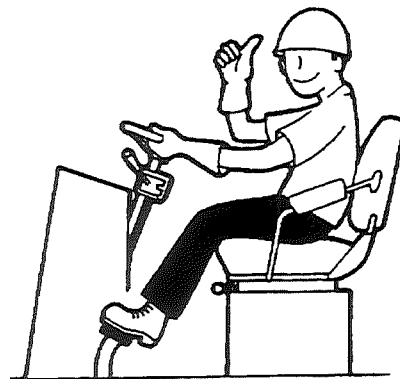

■ **Move Control Levers to Neutral Position**

Check control levers is in "NEUTRAL" position and parking brake is applied.



■ **Starting Engine Only from Operator's Seat**

Do not start engine by shorting across starter terminals.

Never start engine while standing on ground. Start engine only from operator's seat, with Speed Shift lever in neutral and parking brake engaged.

Sound horn to alert persons nearby.

Do not operate machine if start cranks engine with Speed Shift lever in forward or reverse position.

■ **Beware of Exhaust Fumes**

Start and operate engine in well ventilated area only. In enclosed area, vent exhaust to outside. Engine exhaust fumes can cause sickness or death. Prevent asphyxiation.

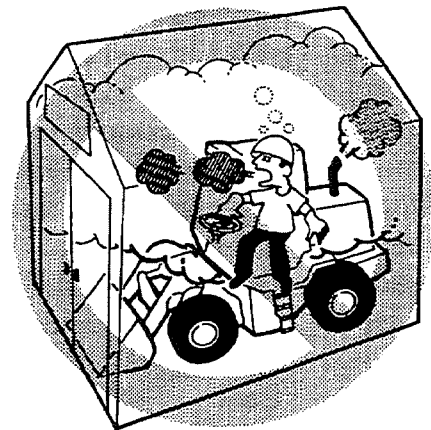

4. After Starting Engine

■ Safety Check of Around

Make sure that there are no persons or obstacles around machine. Use signal person when backing up if view is obstructed. Signal by sounding your horn.

Warn people on machine passage and move them to safety area.

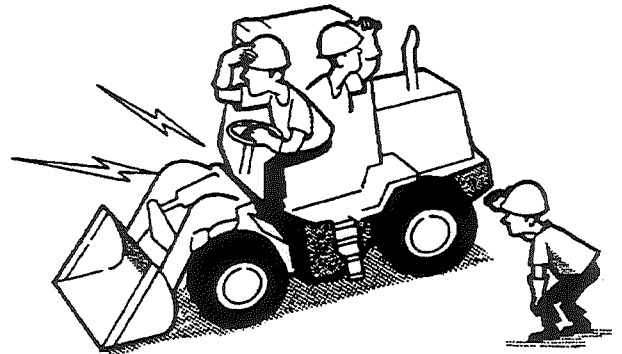

■ Never Carry Passengers

Your machine is material handling device. Never carry passengers.

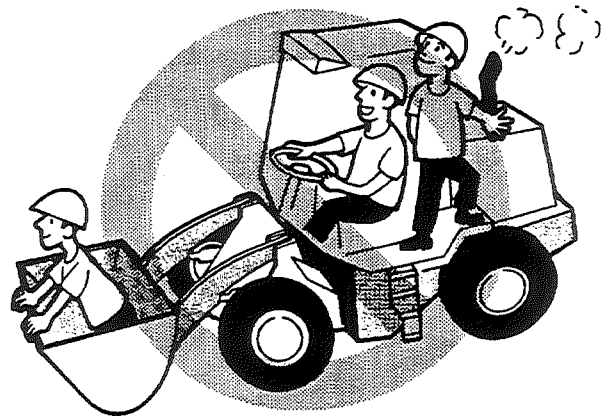

■ Warming-up

Warm up engine instead of operating machine immediately after starting engine.

After warm-up, operate hydraulic control levers several times to check condition of lifting, lowering, and tilting operation of lift arm and bucket. Check that working equipment and its operating condition are normal.

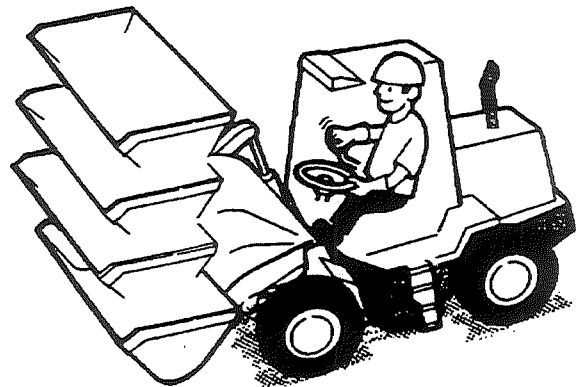

■ Trial Run before Operation

Operate machine in open area and check that transmission, brakes, accelerator, and steering are operating properly.

Do not operate machine if defect is detected. Repair any defect before operation.

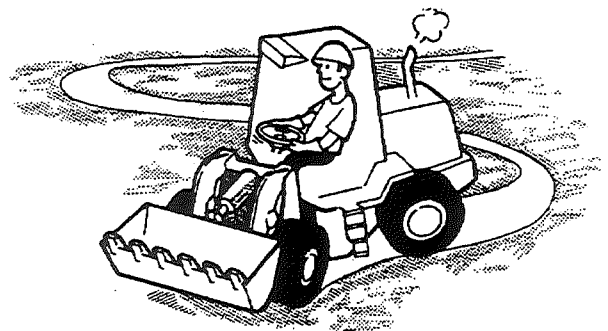

5. Safety Operation

■ Operate Carefully at Night Especially

You are very easy to make mistakes in assuming distance and height of objects and ground at night. Carefully operate machine at speed suitable to illumination.

Be sure to arrange adequate lighting system.

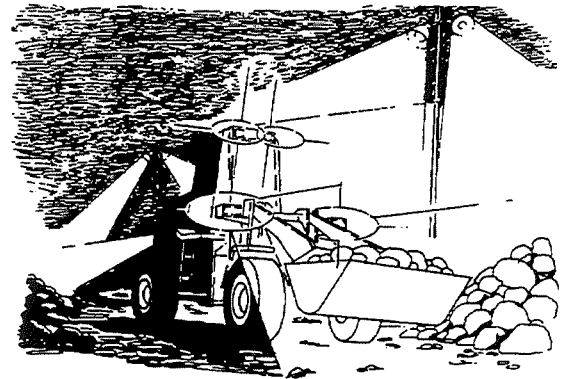

■ Stop Work When Visibility is Poor

If visibility is reduced by smoke, fog or dust, stop work and wait until you get clear visibility.

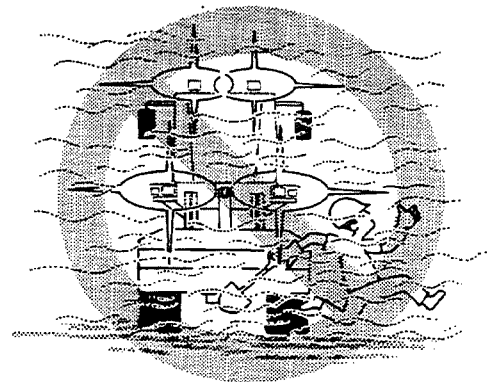

■ Do not Approach High-Tension Cable

Electrical shock may result when you approach high-tension cable. Strictly observe following on work site near high-tension cable.

- Wear rubber-soled shoes.
- Keep safe distance between machine and cable.
- Station signal person who will give warning when machine approaches cable excessively.

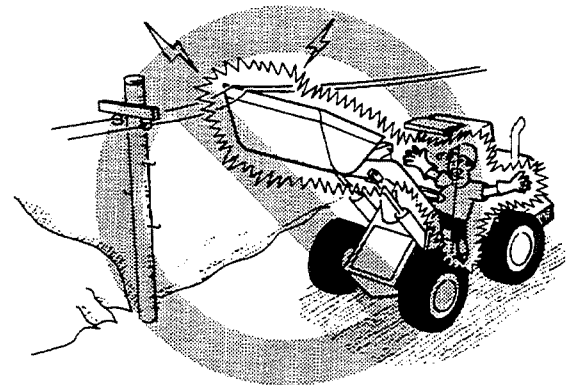

■ Do not Approach Dangerous Spot

When you operate machine on road shoulder or in a place where landslide may occur, take necessary safety measures, assign signal person and follow his instructions



■ **Operate Machine Only Operator's Seat**

Always sit in operator's seat when operating machine.

Do not operate any control lever while engine is stopping

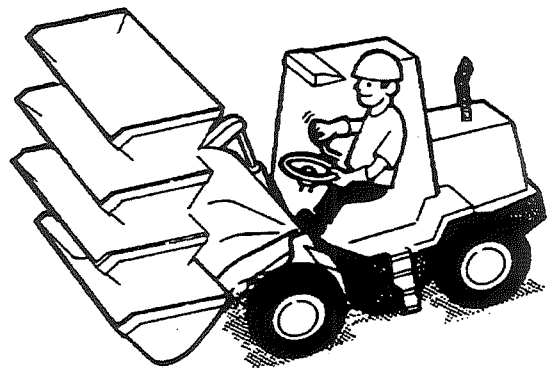

■ **Do not Allow People to Approach**

People will be in danger on work site. Do not allow any person other than guide to enter work site.

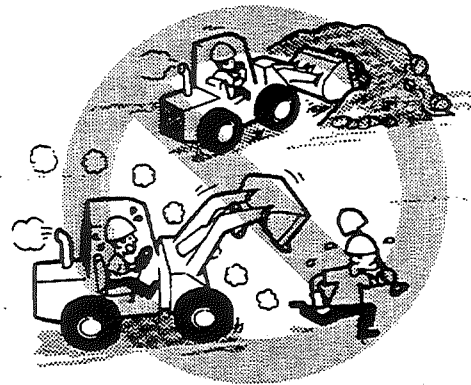

■ **Provide Protections Workers**

Do not allow person to approach operating machine.

Provide necessary protections for workers.

If necessary ask another person to direct and watch dangers.

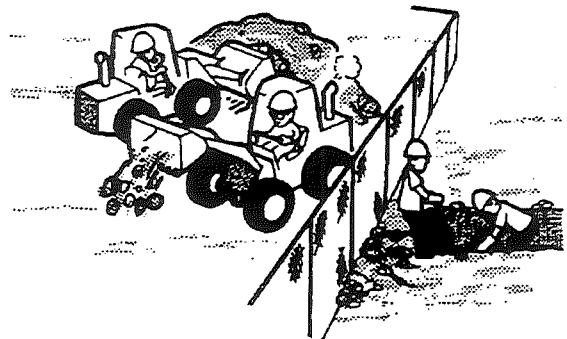

■ **Safety of Other Vehicles and Pedestrians**

When operating machine on road, take measures to protect pedestrians and passing vehicles from accident, such as, assigning signal person(s) or installing barrier. Signal person must be in direct communication with operator, and operator must work close attention to signals.



■ **Safety Check on Changing Direction**

When attempting to change forward and reverse directions, make sure of safety in direction of travel. Be particularly careful to check that rear is clear before backing machine.

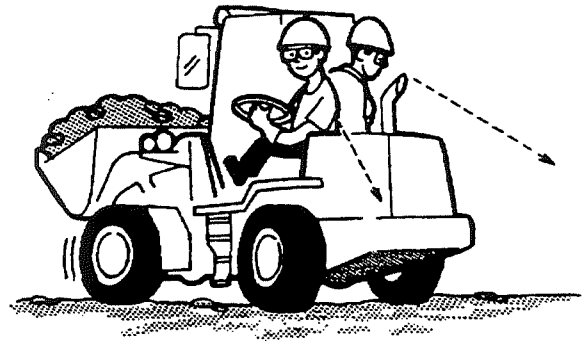

■ **Watch Out for Workers**

Operate machine paying special attention to persons in direction of travel and around machine. If necessary, sound horn for warning of danger.

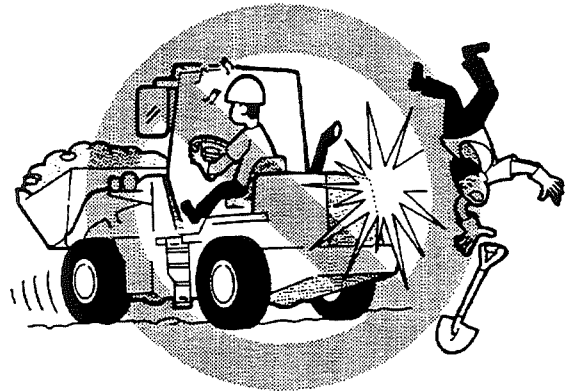

■ **Never Lift Load Over Anyone**

Never lift load over anyone or allow anyone to stand beneath raised bucket.

Do not allow workers entering surrounding area of working equipment.



■ **Never Let Anybody in or Near Articulated Area**

Never allow anybody to enter articulated area of chassis when machine is turning, otherwise serious or fatal crushing injuries will result.

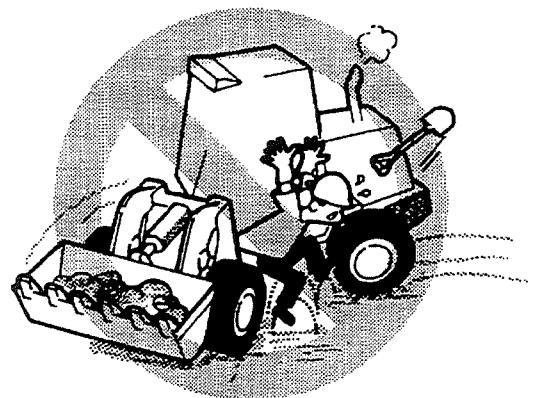

■ **Observe Traffic Rules of Work Site**

For prevention of accident due to contact with vehicles, thoroughly understand traffic rules on work site in advance and follow signs and instructions of signal person. Loaded vehicles cannot stop immediately, so yield way to them at all times.

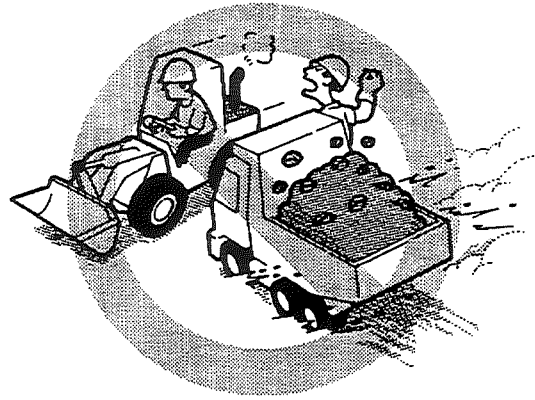

■ **Keep Safe Distance from Others**

Always keep machine under control and safe distance from others. Never pass another vehicle. Use accessory lights and devices to warn operators of other vehicles.

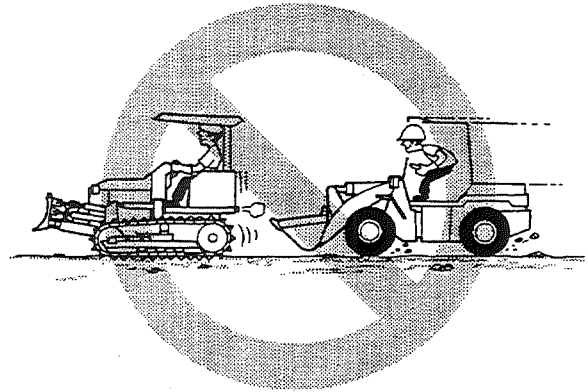

■ **Pay Attention to Surrounding**

In close quarters, carefully travel or steer machine at low speed paying special attention to safety around machine.

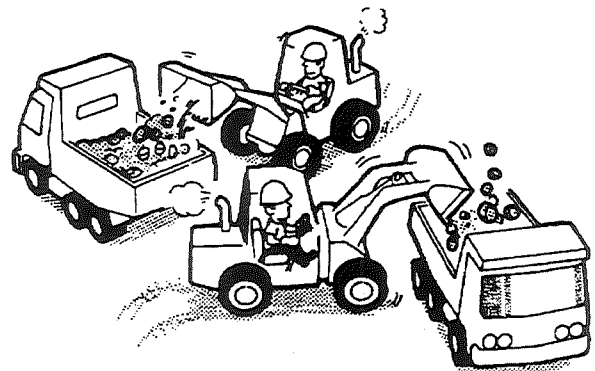

■ **Level Work Site**

Level work site utilizing idle time.

Smooth surface increases work efficiency and makes machine operation easy. If work site is very sandy or dusty, sprinkle water over ground before working on site.

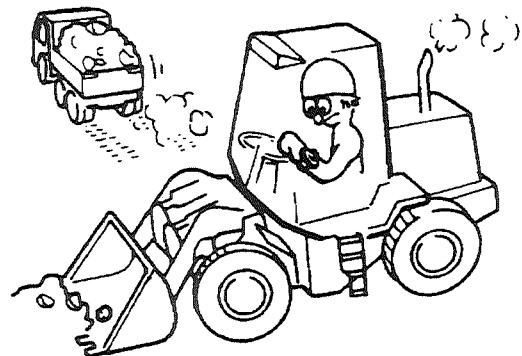

■ **Use of Machine for Operations Other Than Specified Purposes is Prohibited.**

1. Never use bucket for work platform.

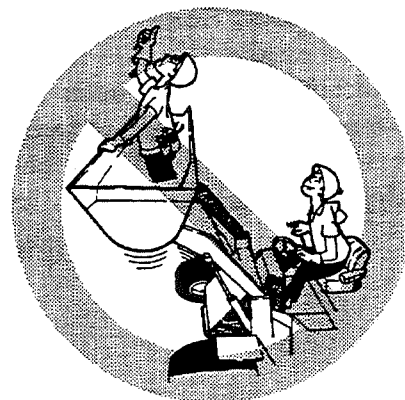

2. Never use machine as crane.
This machine is not equipped with hoist or safety device, so there is risk of falling or drop of hoisted load during crane operation.

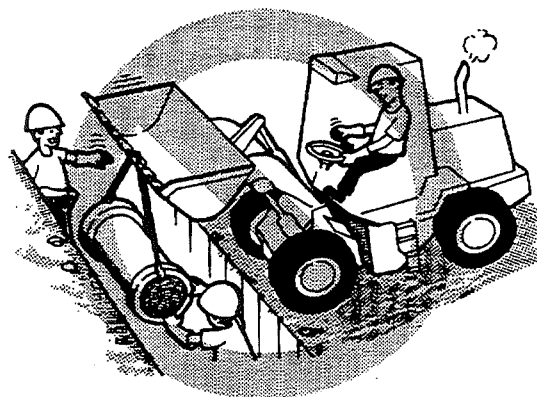

3. Never use machine as battering ram.
Besides damaging machine, it can cause personal injury.

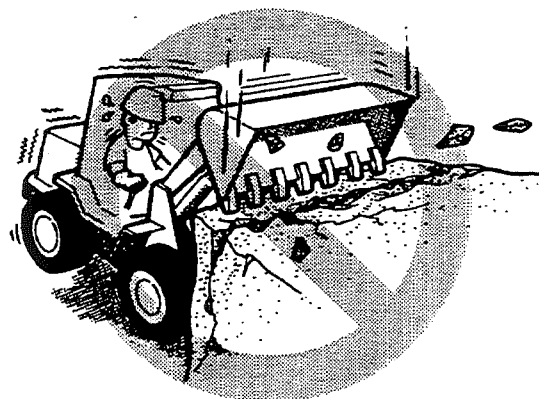

■ **Never Exceed Rated Capacity**

Always be aware of operating capacity of machine. Using machine to do work beyond its capacity will not only damage machine, but may even cause unexpected accidents.

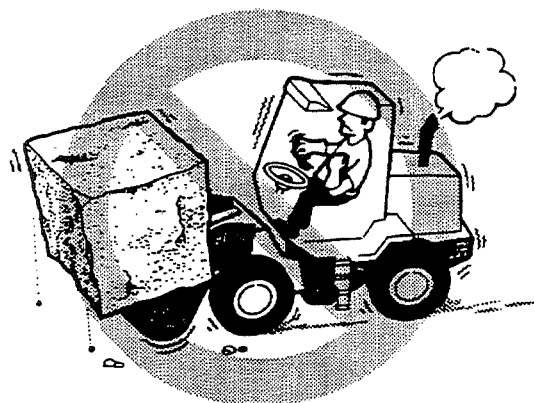

■ **Keep Working Equipment at Safety Height While Traveling**

Carry load with bucket fully tilted back and lowered approx. 40 cm (16 in) above ground level.

Do not carry load with bucket raised excessively.

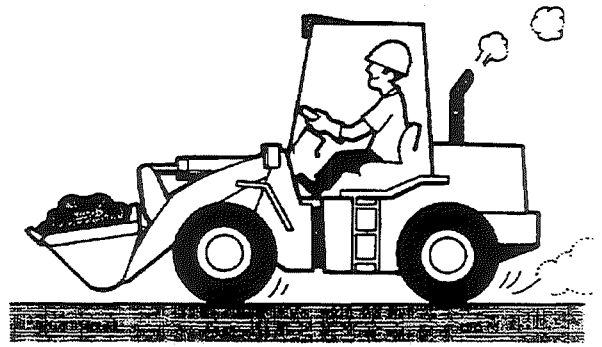

■ **Do not Stop Engine While Traveling**

When engine stops while traveling, power steering device will not operate to result in excessively hard turning of steering wheel.

This is dangerous, so apply brake, lower bucket and apply parking brake. When engine stops accidentally.

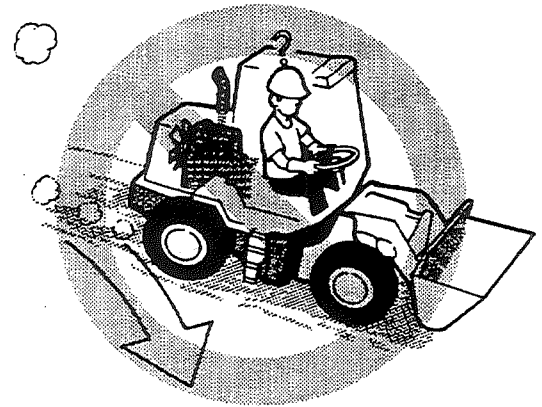

■ **Temporary Stop Machine If Visibility is Poor**

In place where visibility is obstructed, such as entrance or exit, decrease speed and stop machine, if necessary, sound horn to warn.

Ask signal person to direct and watch dangers.

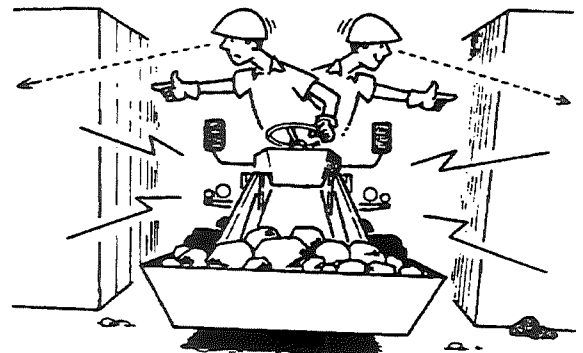

■ **Follow Signal Person**

Always use signal person when operator's view is obstructed in any way.

Operator shall respond to operating signals only from appointed signal person, but shall obey stop signal at any time from anybody.

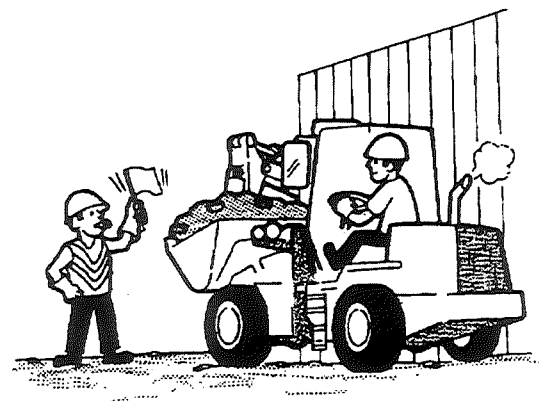

■ **Do not Keep Your Foot on Brake Pedal Unnecessarily While Operation.**

Do not keep your foot on brake pedal unless it is necessary.

When you operate machine with your foot on brake pedal, brake will be overheated, not working properly when necessary.

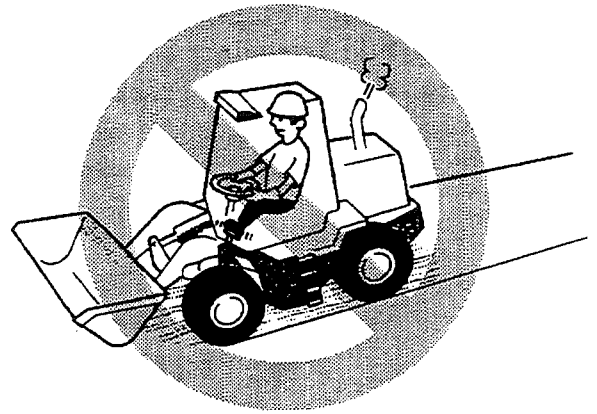

■ **Avoid Rough Operation**

High-speed traveling, sudden starting, turning, braking and jig-zag movement are dangerous.

Always keep machine under control.

Operate controls smoothly and slowly.

Machine may turn over if it is operated roughly while bucket is at raised position.

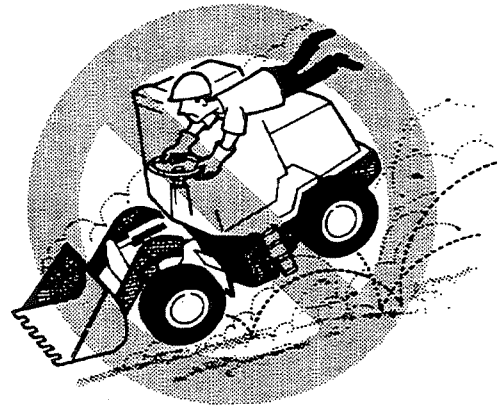

■ **Observe Speed Limit and Avoid Sudden Stops**

Observe work procedure and speed suited to situation of operation.

Considering relation between traveling speed and braking distance, always try to apply brake early.

(See "Stopping Machine".)

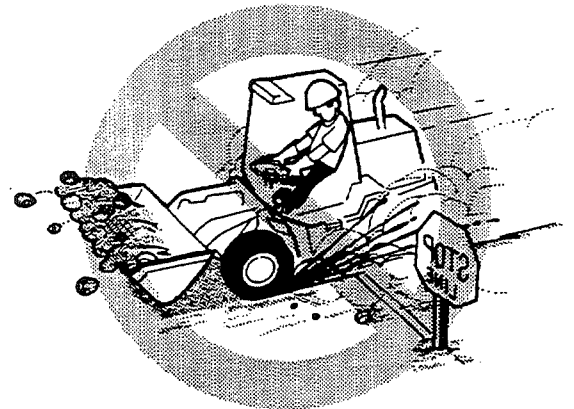

■ **Depress Brake Pedal to Stop**

Bucket should not be used as a brake except in emergency.

Do not use parking brake while traveling as brake.

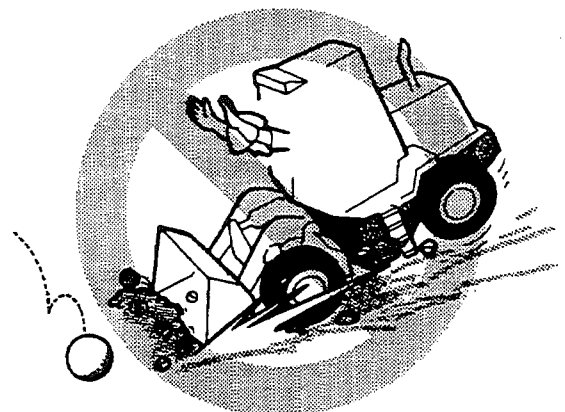

■ **Ensure Combined Weight of Machine and Load Do not Exceed Operating Area**

Investigate travel route for road width and overpass. Check any bridges for weight limits. Ensure combined weight of machine and load does not exceed capacity of planned operating area.

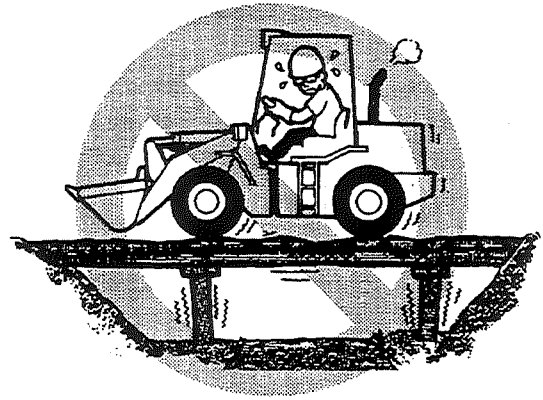

■ **When Passing Through Tunnel or under Elevated Structure**

Contact accident will result when machine passes through tunnel or under elevated structure carelessly. Check that height and width of machine is within limit.

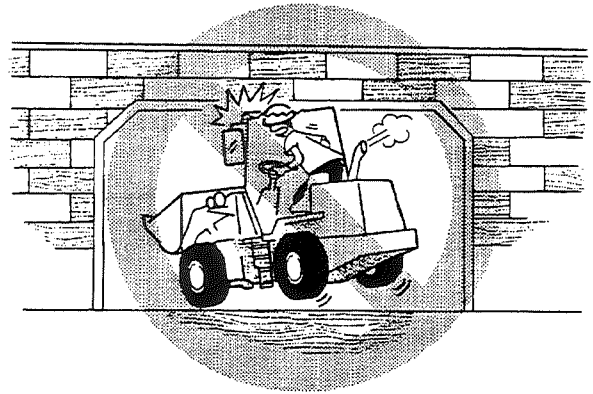

■ **Know Working Area**

When operating machine inside building, know what clearance you will encounter: overhead, doorways, aisles, etc. and also, weight limitations of floors and ramps.

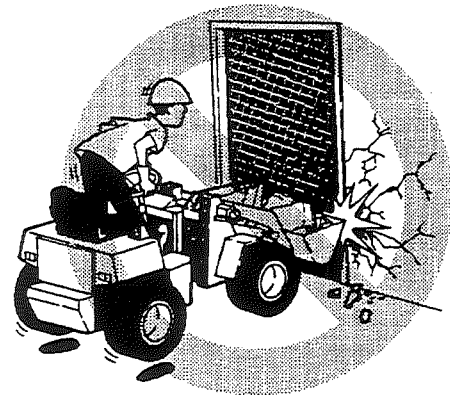

■ **Do not Forget Ventilation for Indoor Operation**

If you must operate machine in building, be positive there is adequate ventilation. Either use exhaust pipe extension to remove exhaust fumes or open doors and windows to bring enough outside air into area.

Exhaust gas is dangerous, and can lead to death.

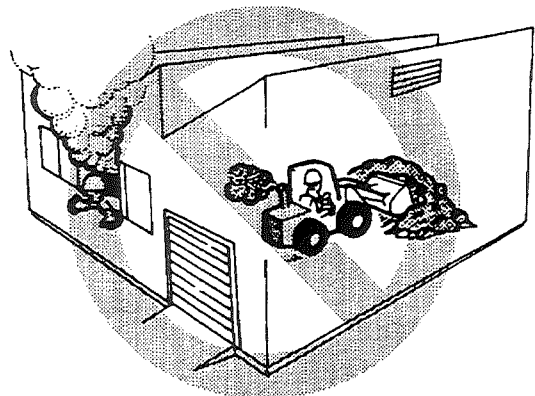

■ **Avoid Sudden Change of Direction or Speed**

Sudden change of speed applies shock to machine, exercising adverse effect on life of machine. Slow down speed with brake before changing traveling direction.

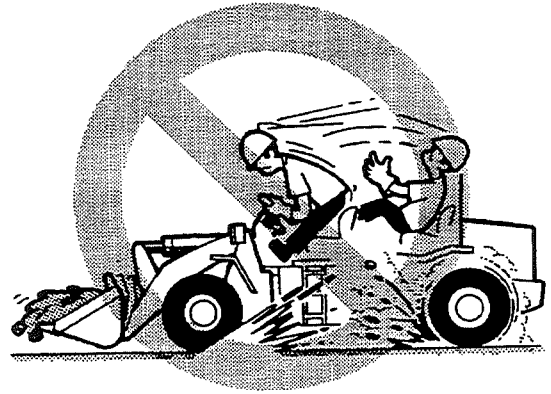

■ **Avoid Sudden Steering**

Do not change traveling lane suddenly since machine may turn over. Especially, when machine travels on slope or bumpy area, move it slowly and do not change passage suddenly.

Avoid sudden steering while travelling or boom is raised high.

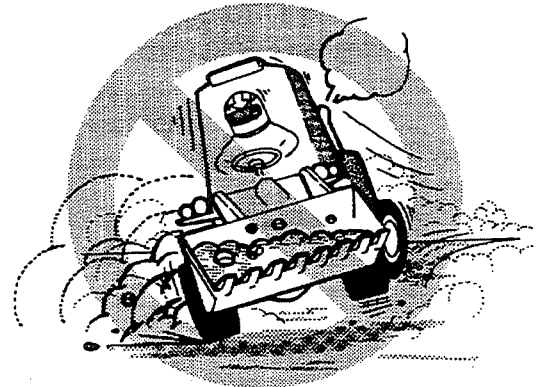

■ **Careful Operating on Bumpy Surface**

Avoid overturn or loss of steering when traveling bumpy surface.

Slow down for maximum safety.

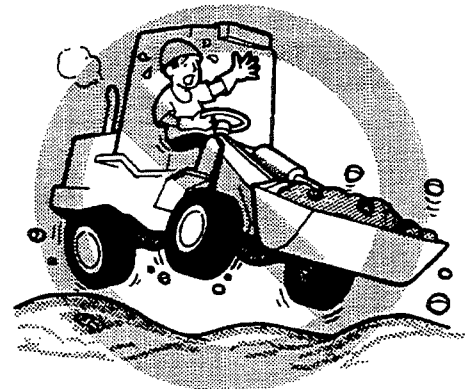

■ **Be Careful on Slippery Surface**

Tires will easily slip on snowy, frozen road, and slope, so avoid sudden braking, starting, and turning.

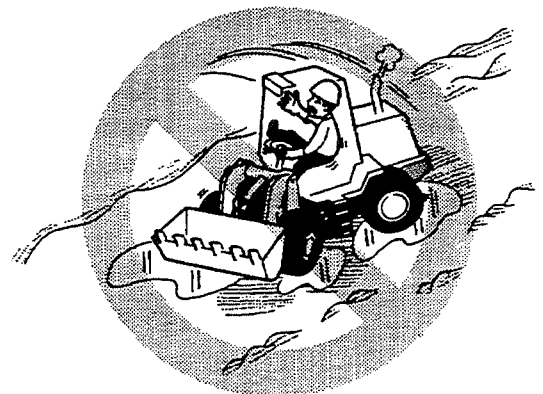

■ Travel Square to Slope

When work on slope, move machine in direction square to slope.

Crossing slope diagonally or parallelly bears danger of turning over or side slipping.

When travel on slope, keep bucket height 20-30cm (8-12inch) from ground.

(See "Precaution for Traveling Uphill and Downhill".)

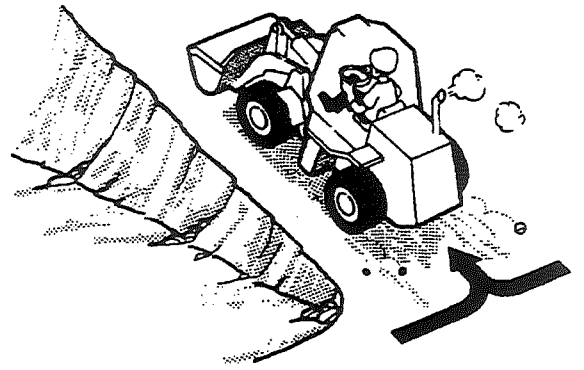

■ Avoid Traverse

Avoid traverse whenever possible. Danger of tipping and/or turn over is always present.

When you must turn machine on slope, select a spot of gentle slope and firm ground and move machine carefully after lowering working equipment.

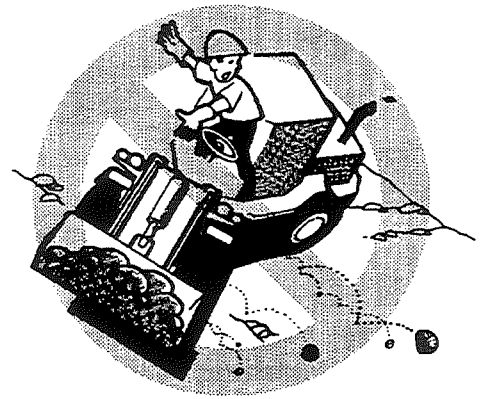

■ Select Proper Gear Shift on Uphill and Downhill

Stop machine before approach to uphill, and select low gear speed suitable for slope. Do not change gear on slope. Use engine brakes on downhill and travel machine slowly. When speed exceeds proper range of selected gear speed, apply brake to lower speed so that engine will not overrun.

When bucket is loaded, go up in forward travel and go down in reverse travel.

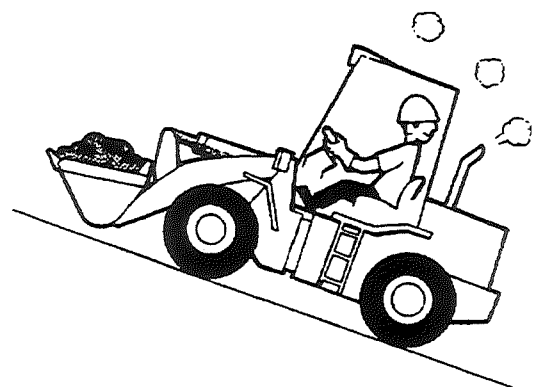

■ **Operate Carefully and Slowly When Bucket is Fully Loaded**

When bucket is full-loaded, operate machine slowly. Sudden stopping, starting and steering are dangerous.

Especially, operate machine carefully when working equipment is raised.



■ **Keep Your Balance**

Keep balance of machine.

When machine is likely to tip forward, lower bucket composedly to keep your balance.

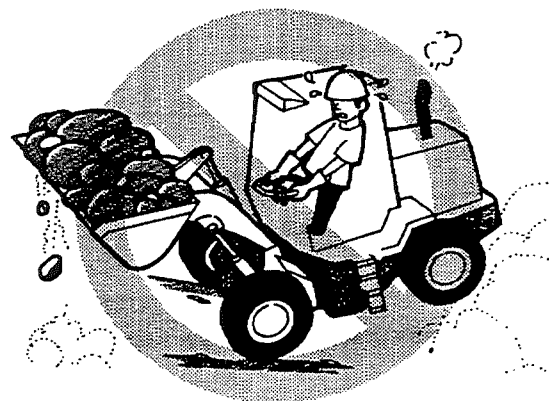

■ **Never Use FLOAT position**

Do not stop or lower work equipment suddenly machine tip over will result. Especially bucket is loaded, operate work equipment carefully.

When lowering loaded bucket, place control lever in LOWER position.

Never operate it with lever in FLOAT position.

FLOAT position is dangerous because lowering speed cannot be controlled.

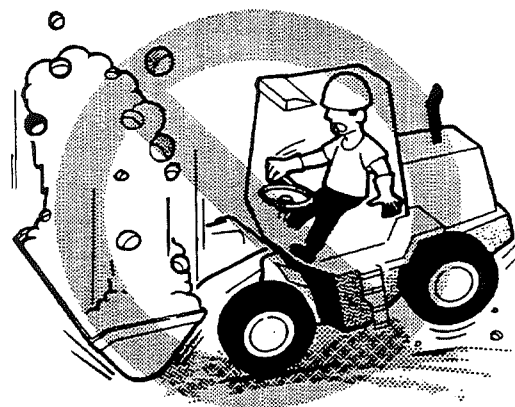

■ **Do not Hit with Bucket**

When loading trucks or hoppers, be careful not to hit truck or hopper with machine or bucket.

Never move load over truck cab.

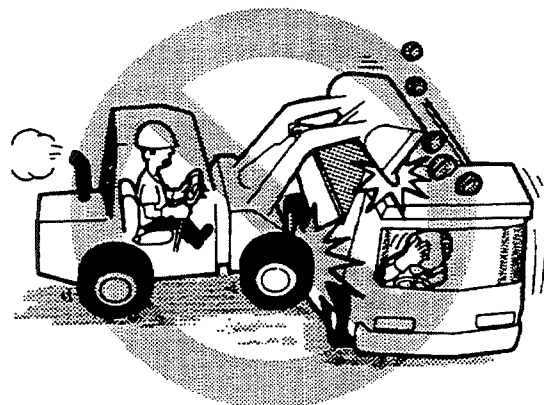

■ **Be Careful of Fall of Unstable Load**

When handling round or cylindrical objects, piled plates, and other unstable objects, they may fall onto operator's seat side in case bucket is raised high, resulting in serious injury or death. When handling unstable objects, exercise care so that bucket will not be raised excessively or tilted excessively backward.

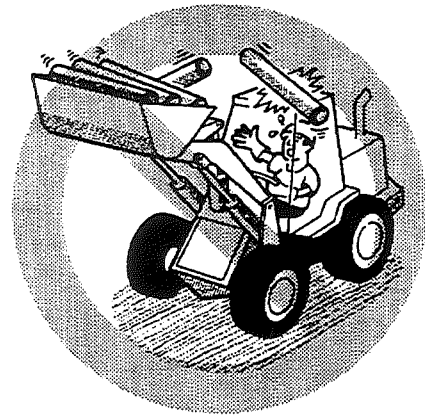

■ **Pay Attention to Wind Direction**

Entry of soil or dust into eyes causes an unexpected accident. Pay attention to wind direction. When loading/unloading, be sure to position bucket leeward so as to avoid dust blowing onto you.

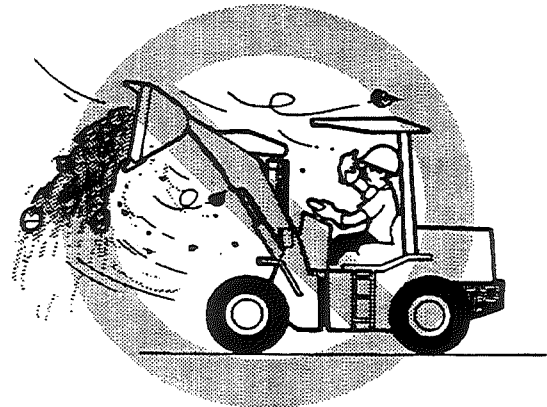

■ **Avoid One-Sided Load**

Load bucket at center. Avoid one-sided loading. When surface is rough, drive machine carefully so as to keep load evenly in stabilized state.

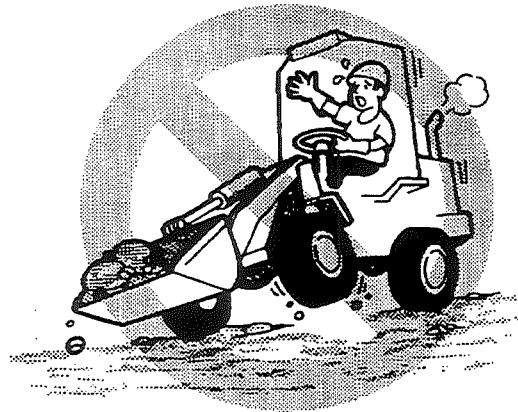

■ **Stay Safe Distance from Slide Areas**

Pay attention to loosening of ground on cliff or road shoulder and do not approach such spot carelessly. Make sure footing is firm enough to avoid cave in. Machine may turn over because of landslide or dropping of wheel.



■ **Digging at High Speed Causes Accident**

Never digging at high speed, it can cause personal injury or machine damage.

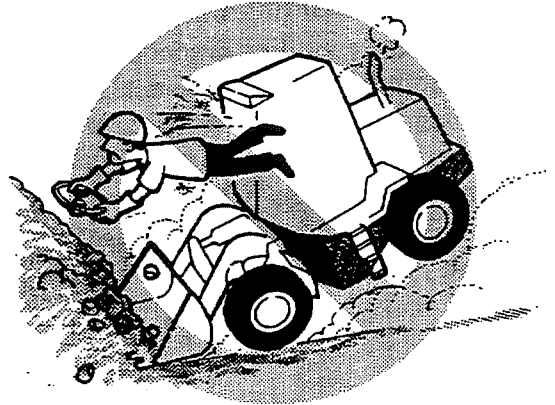

■ **Avoid Digging or Loading in Turning State**

Never tilt bucket back to dig material when machine is articulated, it will result machine is unstable.
(See “Excavating”.)

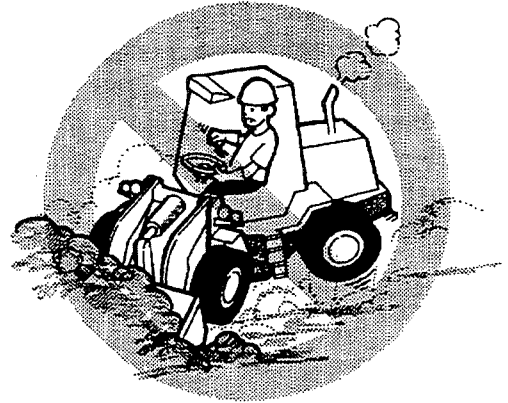

■ **Avoid One Side of Bucket for Digging**

When digging ground with bucket, do not apply force only to one side of bucket. It can cause work equipment damage.
(See “Excavating”.)

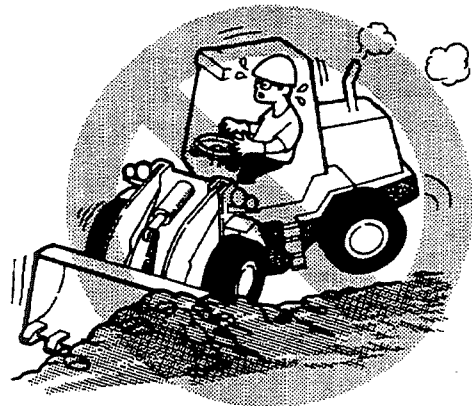

■ **Digging Overhanging Banks is Prohibited**

Digging near overhanging banks is very dangerous operation.
Whole mass can become unstable and cave in.

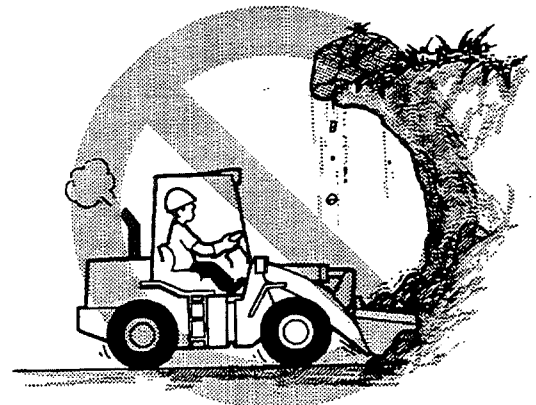

■ **Avoid Excessive Down Pressure on Bucket**

Never operate with front wheels raised to prevent loss of traction and, further, overload may be affect drive train.

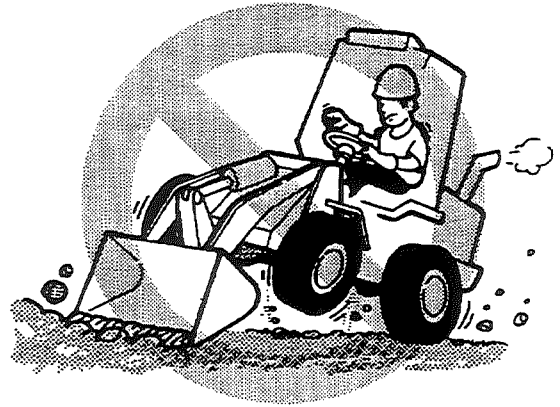

■ **Avoid Spinning Your Wheels**

In excavating and loading operations, do not spin tires.

Tire life may be shortened and high maintenance cost will result.

Spinning can convert smooth area into ruts that tend to tip machine. Keep work area as smooth as possible.

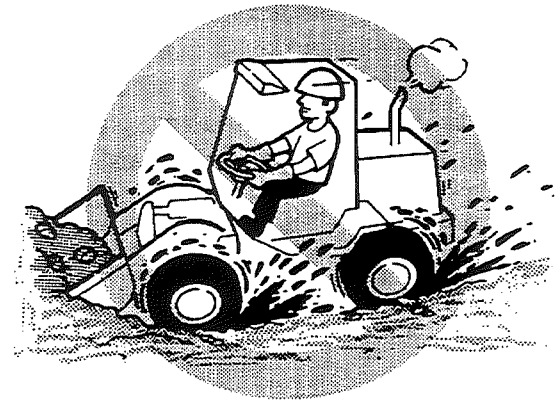

■ **Be Careful When Dropping Load at Cliff Top or Reaching Slope Top**

Load decreases and speed increases immediately.

When dropping off load soil at cliff top, slow down travel speed. Stay safe distance from edge of cliffs.

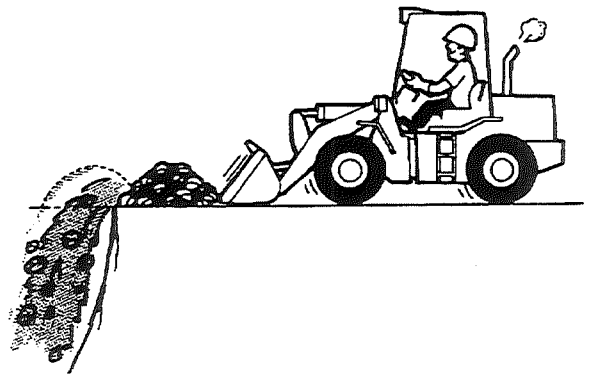

■ **Check Safety of Place Where Load is Dumped**

When dumping soil or rocks from height, make sure of safety of place where these materials are dumped.

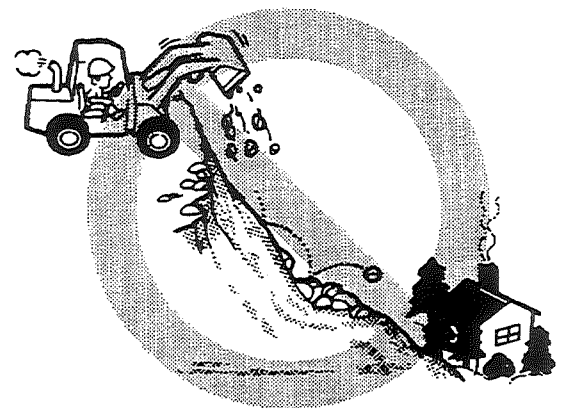

■ **Do not Enter Soft Ground**

Exercise care so that machine will not get stuck in soft ground. Avoid frequent steering on soft ground, and do not travel on same surface repeatedly.

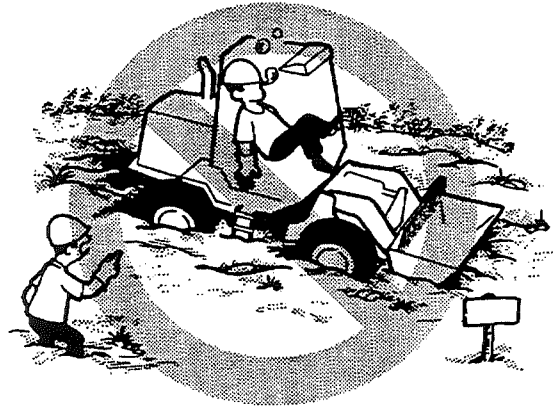

■ **Repair Any Defective Part Immediately**

When failure occurs while operation, report it immediately to your foreman and do not operate machine before repair. If any warning light come on, move machine to open area and check it.

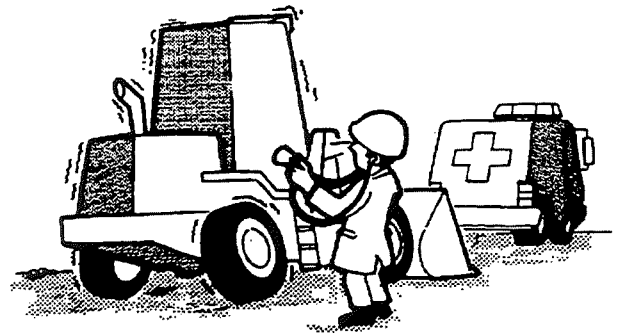

■ **Even Small Defect Causes a Major Damage**

If you notice even small defect, report it to your foreman.

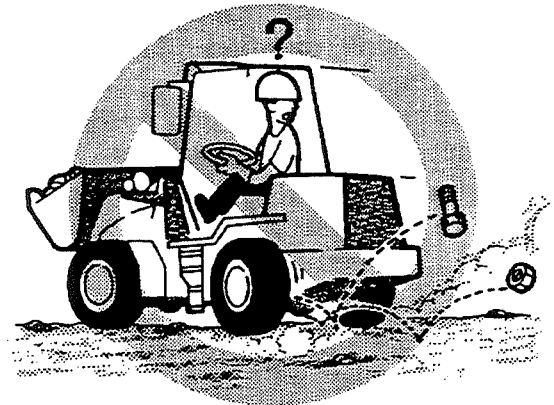

■ **Handling of Disabled Machine**

When transport disabled machine, secure it and chock tracks.

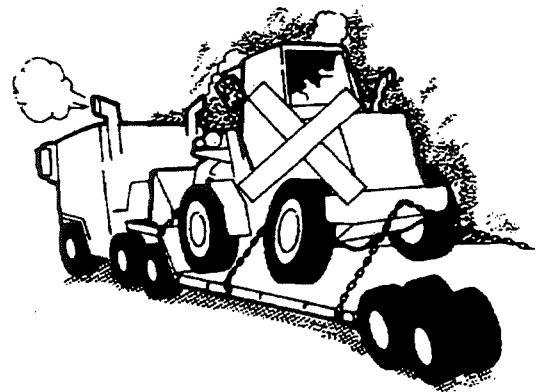

6. Snow Condition

■ Attach Tire Chains Before Starting Snow-Removing Work

When you operate machine on snow, attach tire chains or use machine with snow tires.

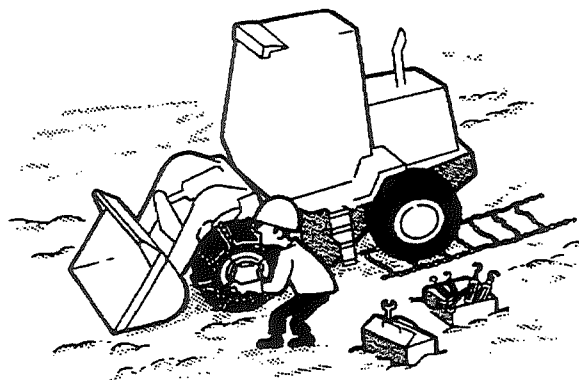

■ Pay Attention to Road Shoulder and Structures

When you remove snow on road, pay attention to road shoulder and structures since they are covered with snow.

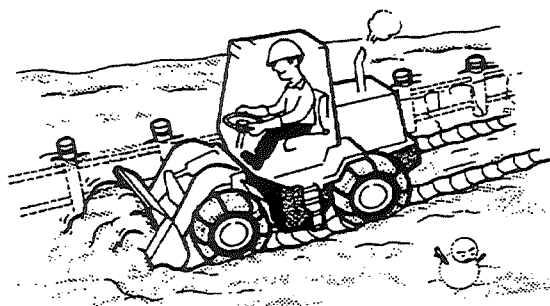

■ Be Careful of Side Slipping

Machine tends to slip sideways even on slight slope while snow remove. Avoid operating machine beyond its capacity or overspeeding.



■ Avoid Sudden Braking

Never apply sudden braking on snowy road. This is especially important on slope since control of machine is lost.

Lower working equipment to ground to stop machine.

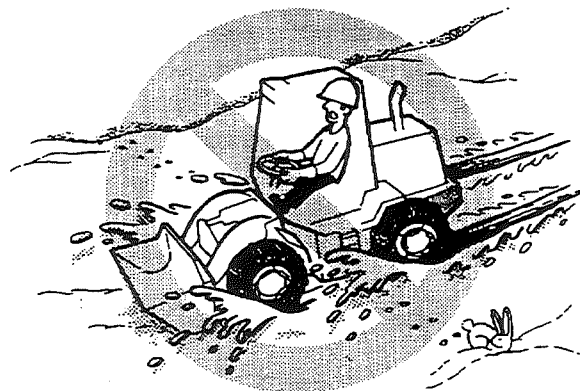

7. After Operation

■ Parking Machine

Select firm ground for parking.

Machine parked on slope may drift by its own weight. If machine has to be parked on slope, park it at right angles to slope and chock tires to prevent movement. If bucket can be pushed into ground, do so when parking.

(See "Parking Machine")

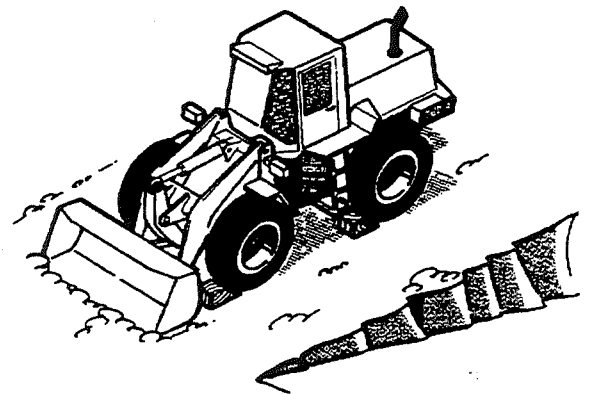

■ Place Clear Signs When Parking on Street

If you must park machine on street, use appropriate flags, barriers, flares and warning signals as required. Be sure that machine is parked in position of not disturbing other vehicles and pedestrians.

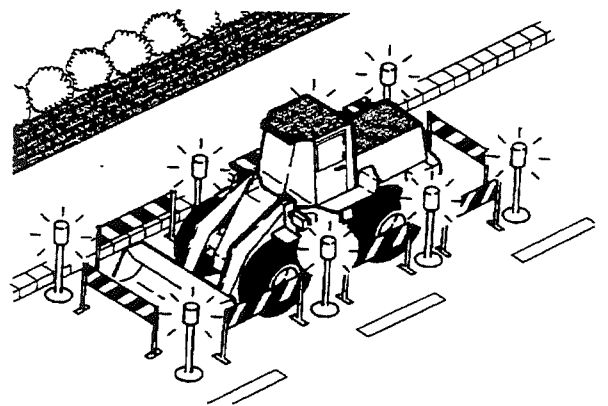

■ Check Safety When You Leave Machine

- Move Speed Shift lever to NEUTRAL.
- Apply parking brake.
- Lower bucket to ground.
- Stop engine.
- Move hydraulic control levers to relieve hydraulic pressure.
- Set all control levers to hold position and apply each lever lock.
- Remove starting switch key so that prevent unauthorized starting or moving machine.
- Firmly place chocks against tires to prevent rolling, especially if parked on slope.
- Install all vandalism protection locks and covers.
- Keep key in specified place.

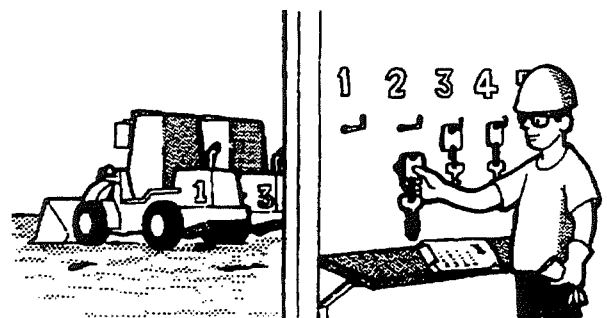

■ **Clean and Check Machine After Operation**

Clean machine thoroughly. Remove any grease, oil or dirt buildup to facilitate spotting of loose or defective parts and minimize fire hazards.

Check condition of machine at end of each day; report any damage or defects to your supervisor.

(See “Prepare Machine for Storage”.)

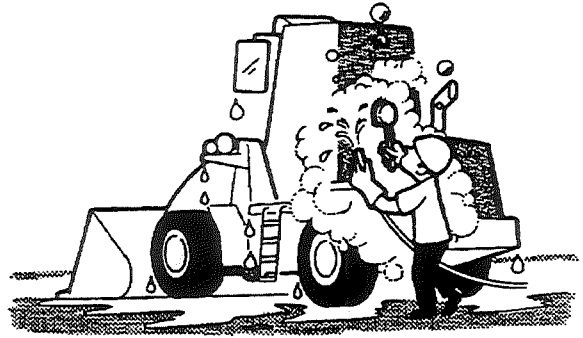

■ **Prepare Machine for Storage**

Store inside after cleaning and checking. If store outside, lay lumber on level surface and cover with water-proof material.

(See “Prepare Machine for Storage”.)

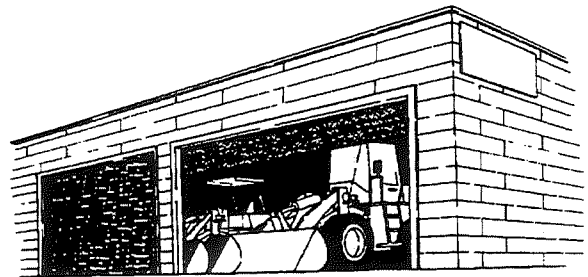

8. Transporting

■ Load and Unload

Loading and unloading of construction machinery on trailer require close attention to safety.

Method of loading machine varies by sizes and types of loader but you must observe following always.

- Park trailer on level and firm surface.
- Keep trailer bed and ramps clean.
Put chocks against truck wheels.
- Use ramps or loading dock.
Ramp capacity must be greater than weight of loader, have low angle, and correct height.
Use ramp equipped with hooks so that it will not come off trailer bed.
- Place center of machine over center of trailer.
- Drive machine onto ramps slowly.
- Go up ramps and never steer halfway on ramps.
When changing course, descend first of all.
- After machined is in position on trailer, connect steering frame locking bar to hold articulated frame rigid.
- Lower bucket onto blocks or trailer bed.
- Move Speed Shift lever to neutral. Apply parking brake.
- Stop engine and remove starting switch key.
Move control lever to relieve hydraulic pressure.
- Place chocks against tires and tie down machine to trailer with chains or wire cables.

(See "Precautions for Loading and Unloading".)

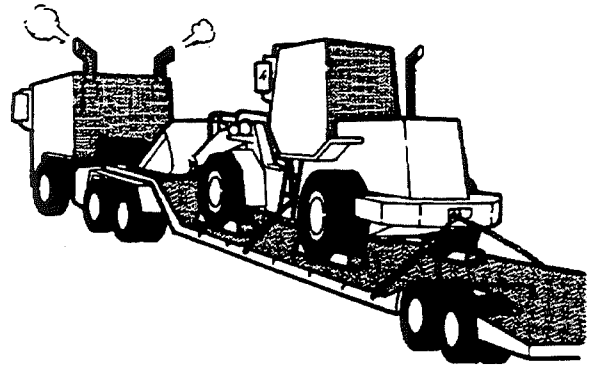
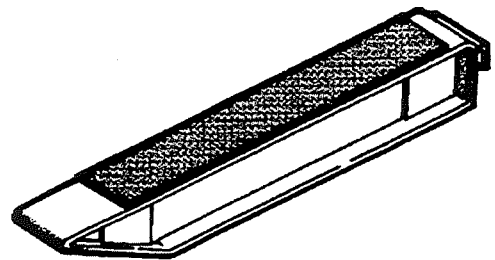
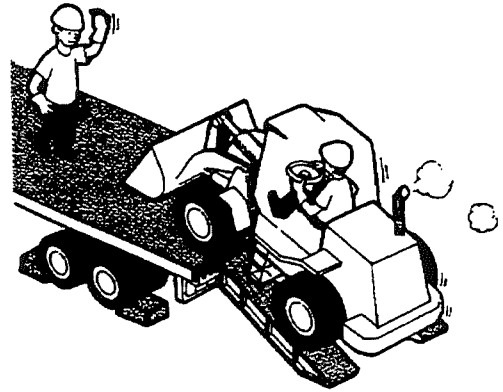

■ Transporting

Obey local laws governing weight, width and length of load.

Observe all regulations governing wide loads.

Investigate travel route for road width and overpass.

Check any bridges for weight limits.

(See "Transporting" .)

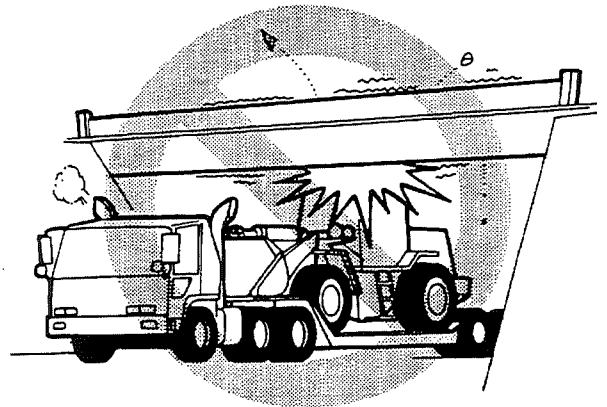

■ Travel on Public Road

When you travel on public road, safely drive machine, pay attention not to disturb road traffic and observing traffic regulations. Keep carry position when traveling.

(See “Precautions for Self-Driving”.)

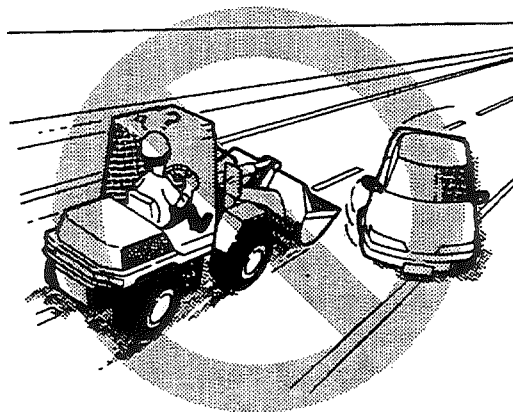

■ Traveling Long Distance

When machine is driven on highway for delivery, or moved by operator to new job site, special precautions must be observed to protect tires. If precautions are not observed, excessive tire heat may build up and tires may fail prematurely.

Always consult your tire dealer for specific information before starting out on trip.

Damaged tires will result to serious injury. Pay attention to following when traveling continuously.

- Check inflation pressure before starting out each day and correct to pressure recommended for highway by your tire dealer
- When traveling long distance, stop for 30-minutes cooling period after 1 hour sustained operation.
- Do not reduce inflation pressure by “bleeding” tires while highway driveway.
- Do not drive with “dry ballast” in highway driveway.

(See “Precautions for Self-Driving”.)

9. Towing

■ Towing

Tow machine only in emergency for short distance. Do not tow machine over long distance. Machine is not supposed to be towed unless it is unavoidable. Pay attention to following when towing machine:

- Towing failed machine in wrong way will cause serious injury or death.
- Machine may be towed only for short distance for inspection and repair. When long-distance towing, use trailer.
- When machine is backed for connection with object to tow, operate machine in accordance with signal person. Confirm safety of operator before starting towing.
- Machine that tows another must be same or larger than machine to be towed. Towing machine must have sufficient braking functions, weight, and tractive force, and it must be able to control both machines on slope and towing route.
- Towing on slope is prohibited.
- Connect machine to tow and that to be towed in line.
- When machine begins to move suddenly, tow rope or bar may be overloaded and broken. Move machine slowly at constant speed.
- Do not use kinked or twisted tow rope.
- Check that there is nobody in space between towing and towed machines.

(See "Towing" .)

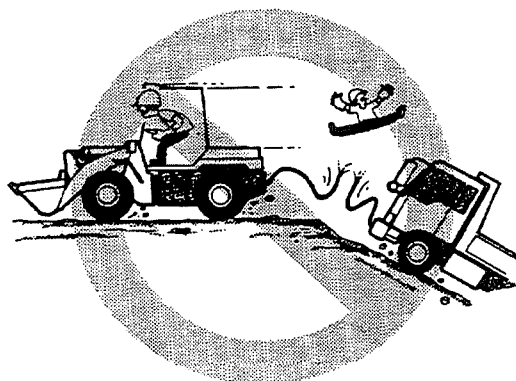
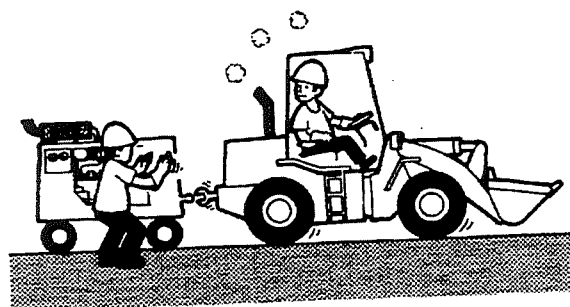
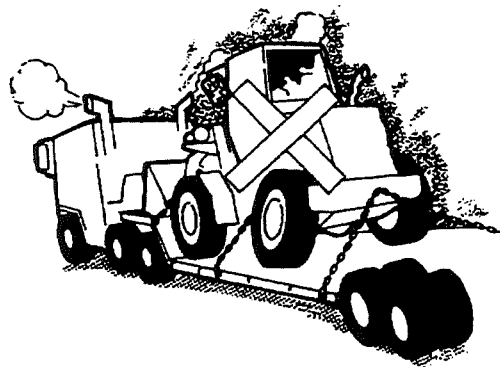

Safety Maintenance

1. Basic Understanding

■ Read “Maintenance” Section in This Manual and Fully Understand Contents.

Before maintain machine, carefully read manual (Maintenance section) and fully understands contents.

Any description marked with  in chapter is very important part for safety.

Be sure to observe these cautions.



■ Read and Obey Safety Signs

Safety signs attached to machine provide important precautions for prevent personal injury.

Read safety signs before maintenance.

(See “Safety Signs”.)

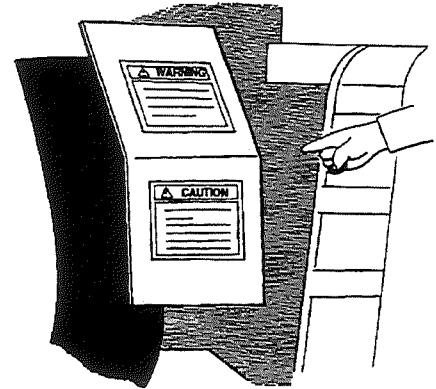

■ When Working With Others

Follow job instruction when you work jointly with others on repair of machine or mounting/dismounting attachment.

Know what other people are doing.

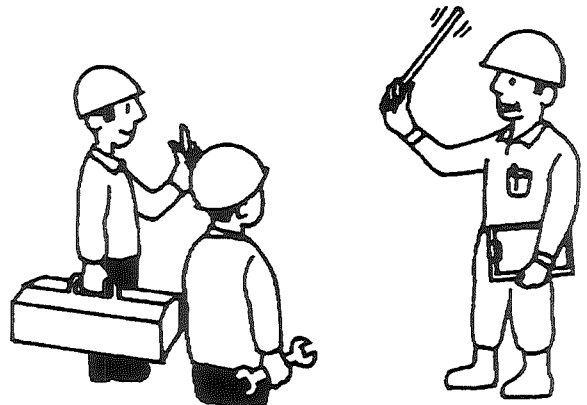

■ Wear Protective Clothing

Wear hard hat, safety glasses, safety shoes, working gloves and other protective equipment, as required by job conditions.

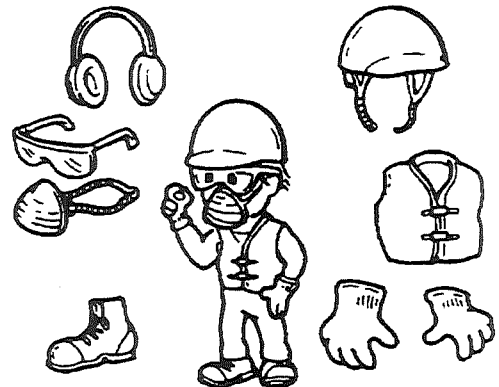

■ Complete Preparation

When performing any service on machine, do following steps unless otherwise specified.

- Park machine on level surface.
- Move Speed Shift lever to NEUTRAL.
- Apply parking brake.
- Lower bucket to ground.
- Stop engine.
- Move hydraulic control levers several times to relieve hydraulic pressure.
- Set all control levers to hold position and apply each lever lock.
- Remove starting switch key so that prevent unauthorized starting or moving machine.
- Place chocks against tires to prevent rolling.
- Install steering frame locking bar in locking position.
- Disconnect battery to prevent accidental starting.
- Attach "DO NOT OPERATE" tag to steering wheel or starting switch.

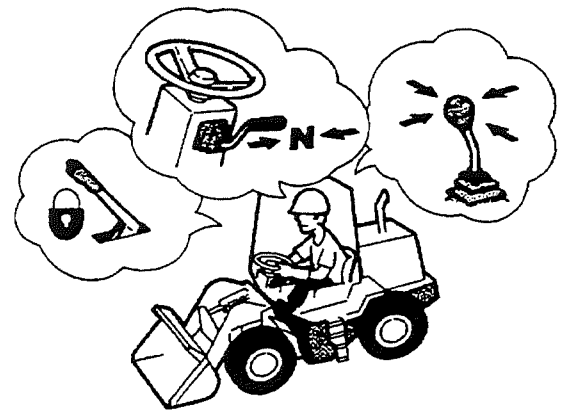

■ Use Proper Tools

Always check tools to be used.

When improper tool is used, part is damaged and, further, you may be injured.

Use proper tool and work carefully.

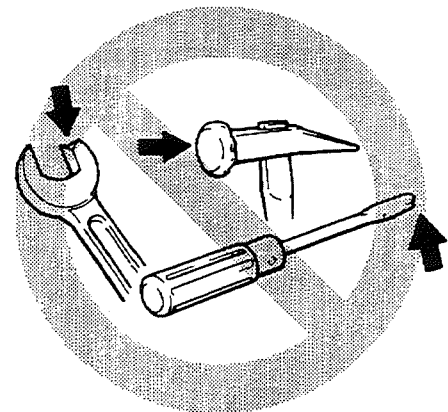

■ Periodical Replacement of Safety Parts

Repalce safety parts periodically with new ones even if they are normal. They will be deteriorated as time passes. If some anomaly is found in safety parts, change or repair them even before their specified term of validity comes.

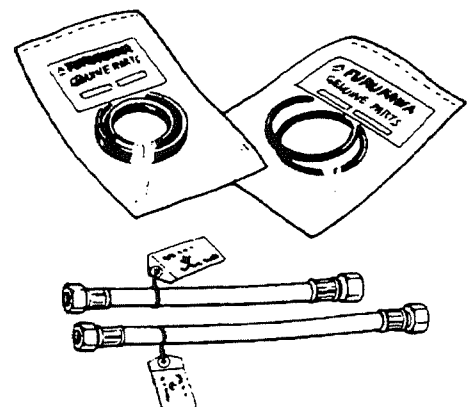

2. Before Maintenance

■ CAUTION Sign;

When you maintain machine hang CAUTION tag in operator's compartment to prevent anyone from starting engine or moving machine. If necessary, place similar caution sign on outside of machine.

CAUTION tag Part no.HF332881-61160

CAUTION tag is in tool box.



■ Lower Working Equipment and Stop Engine

Do not maintain machine while working equipment is raised and engine is running.

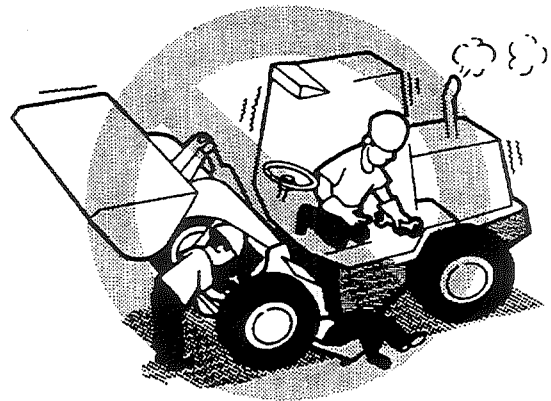

■ Support Raised Working Equipment

Before doing any work, place equipment on ground to avoid accidents.

Put support under raised working equipment. Never work under raised working equipment without support.

If support is not available, lower working equipment to ground.

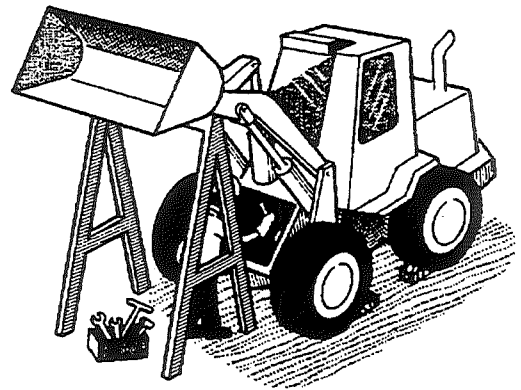

■ Lock Front and Rear Frames

Connect steering frame locking bar to both frames if performing service in center pivot area.

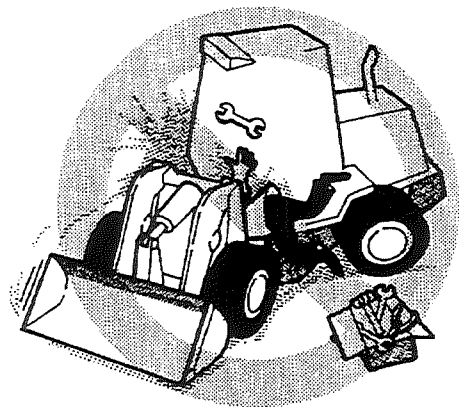

3. Maintenance

■ Do not Allow to Unauthorized Persons

Do not allow unauthorized persons entering place of maintenance.

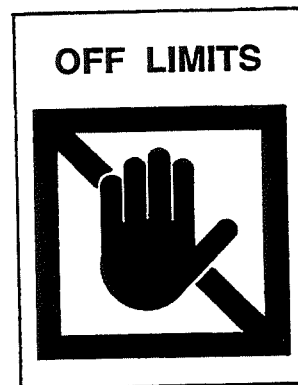

■ Exhaust Gas is Dangerous

If you have to work in building, make sure there is enough ventilation. Draw exhaust gas outside of building with extension pipe.

Engine exhaust gas can cause sickness or death. Prevent asphyxiation.

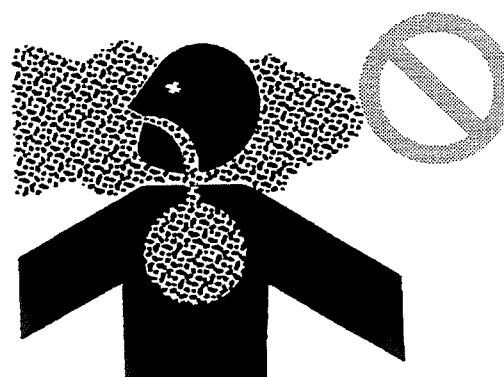
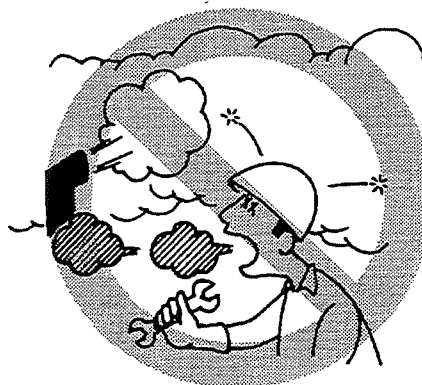

■ **Keep Work Site Clean and Dry**

Keep work site floor and machine free of foreign materials, such as, tools, oil, debris, since they can catch accident. Keep work site clean and dry always.

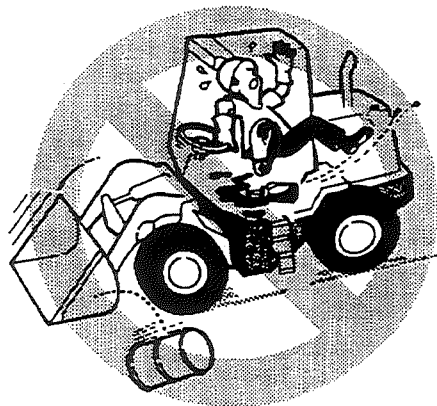

■ **Hot Oil and Components Can Cause Injury**

All parts are hot immediately after operation and if you touch any part, you may get burn. Wait until temperature of these parts drops before starting maintenance.

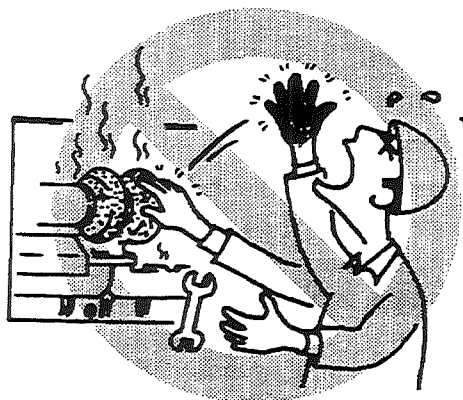

■ **Relieve Pressure in All Systems Before Working on Machine**

Always relieve pressure in circuit before maintain oil, coolant. Don't forget hydraulic system may be pressurized. Stop engine before maintain hydraulic system and relieve hydraulic pressure.

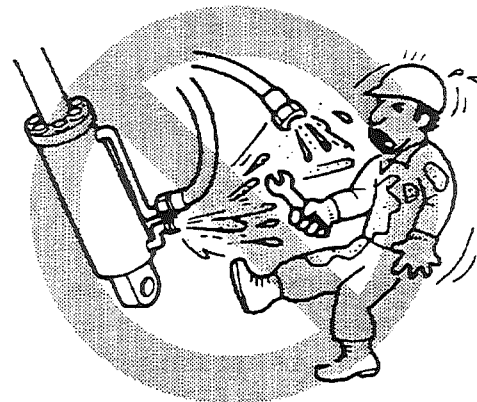

■ **Do not Open Radiator Cap**

Check coolant level only when engine is stopped and radiator cap is cool. Only remove radiator cap when radiator is cool.

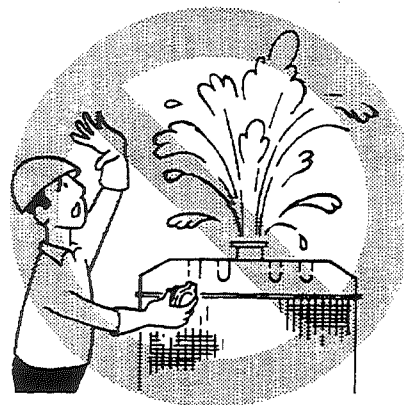

■ Do not Drain Hot Oil

While operation, oil and air in sealed hydraulic tank become hot and will tend to expand. Do not open or drain hot hydraulic tank; hot oil can rush out if filter cap or drain plug is removed and can cause serious burns.

Always relieve tank pressure before removing cap completely.

Fluids must be drained into containers. Spilled oil must be cleaned up as it catch fire.



■ Avoid Fires

Fuel and most lubricants are flammable.

Handle it with care.

When refill it, observe following instructions.

- Stop engine and turn starting switch to "OFF" position.
- Do not smoke or allow open flame in area.
- Refill outdoor or in well ventilated area.
- Do not refill over proper level.
- Tighten cap securely after refilling.

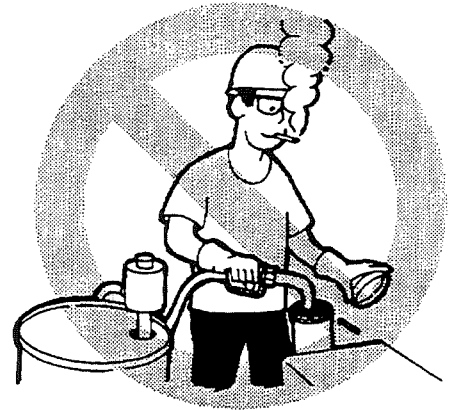

■ Avoid High-pressure Fluids

Leakage of high-pressure fluids (hydraulic oil or fuel) your skin or eyes, causing serious injury or loss of eyesight.

Leakage of high-pressure fluids may not be visible occasionally. For inspection of leakage, wear safety glasses and thick gloves, and apply thick paper, or plate of wood location to inspect.

Do not use bare hand for inspection.

If you have touched high-pressure fluids, consult doctor immediately.

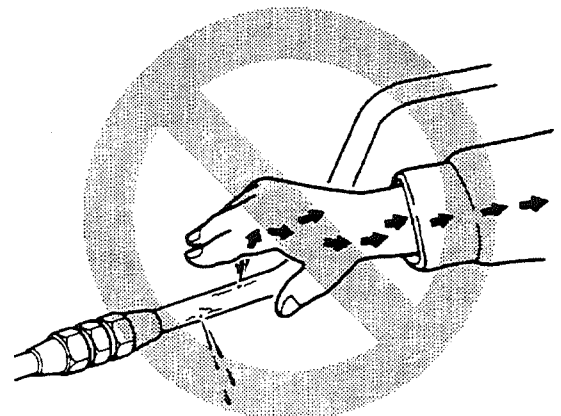

■ Remove Paint Before Welding or Heating

Avoid potentially toxic fumes and dust.

Hazardous fumes can be generated when paint is heated by welding, soldering, or using a torch.

Do all work outside or in well ventilated area.

Dispose of paint and solvent properly.

Remove paint before welding or heating:

- If you sand or grind paint, avoid breathing dust. Wear approved respirator.
- If you use solvent or paint stripper, remove stripper with soap and water before welding. Remove solvent or paint stripper containers and other flammable material from area. Allow fumes to disperse at least 15 minutes before welding or heating.

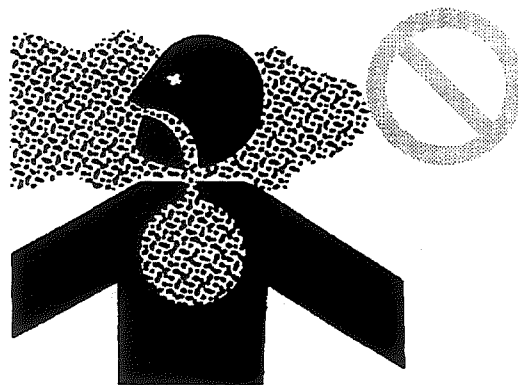

■ Use Nonflammable Cleaning Solvent to Clean Parts

Use nonflammable cleaning solvent to clean parts. Gasoline is highly flammable and should never be used as cleaning fluid.

Do not weld or gas cut on pipes or tubes in which oil remains. Clean out thoroughly with steam or nonflammable cleaning solvent before welding or gas cutting on them.

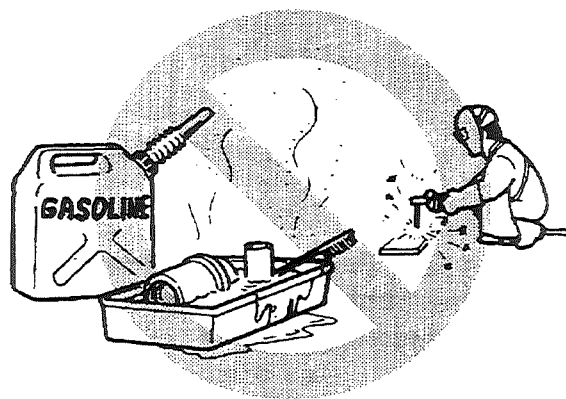

■ Avoid Heating Near Pressurized Fluid Lines

Flammable spray can be generated by heating near pressurized fluid lines, resulting in severe burns to yourself and bystanders. Do not heat by welding, soldering, or using torch near pressurized fluid lines or other flammable materials. Pressurized lines can be accidentally cut when heat goes beyond immediate flame area.

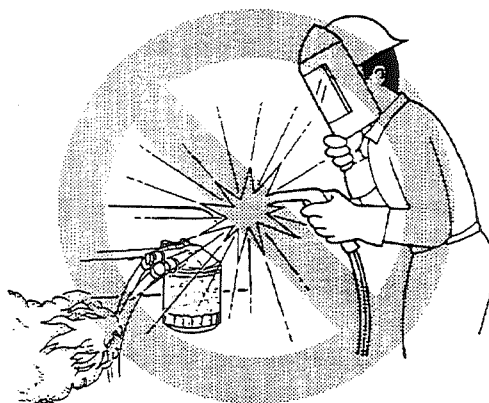

■ **Never Use Flame for Illumination**

Use explosion-proof lighting equipment for inspection of fuel, oil, coolant, and battery fluid. Do not use open flame for illumination.



■ **Do not Maintenance While Engine is Running**

Stop engine before maintenance. Do not touch running fan, pulley, belt, and other moving parts, otherwise you may be caught in them and your fingers or hand may be cut off.

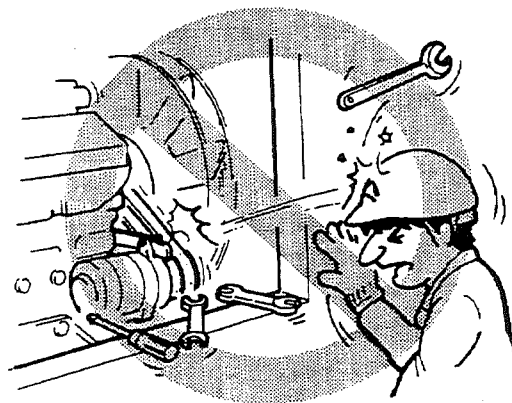

■ **Two Men Should Work Together on Maintenance While Engine is Running**

Be sure to stop engine before working on maintenance. If it is necessary to keep engine running, two men should work together. One man must be on operator's seat while other works on maintenance. Safety must be checked each other. Pay close attention to moving parts.



■ **Starting Engine Only From Operator's Seat**

Prevent possible injury or death from runaway machine. DO NOT start engine by shorting across starter terminals. Machine will start in gear if normal circuit is bypassed. Never start engine while standing on ground. Start engine only from operator's seat with Speed Shift lever locked in neutral and park brake applied.

■ Precautions for Maintenance at High Place

Before starting maintenance at high place, secure footing to prevent fall.

- Do not spill oil or grease.
- Do not scatter tools about.
- Do not jump onto or off machine.
- Use safety belt and safety equipment as necessary according to nature of work.



■ Support Jacked Machine

Method to jack up machine must be correct, otherwise operator may be crushed by machine due to release of hydraulic pressure or fall of machine.

- Do it on level, hard ground.
- Lock frame in front and rear and apply chocks to tires before jacking up machine.
- Capacity of jack must be sufficient to support weight of machine. Do not use attachments or other objects used for work in place of jack.
- After jacking up machine, support it with strong block instead of hydraulic jack.

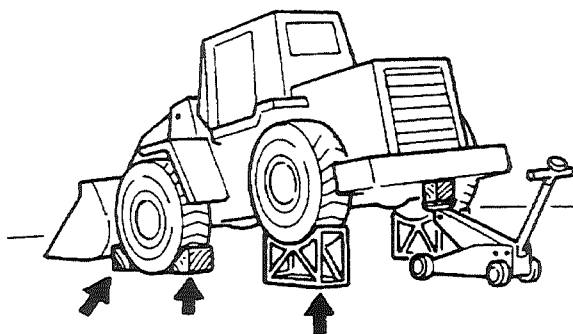

■ Protect Against Flying Debris

When you drive connection pins in or out, guard against injury from flying pieces of metal or debris; wear goggles or safety glasses.

Connecting pins, when hammered, may pop out, so do not allow people to stand in that direction.

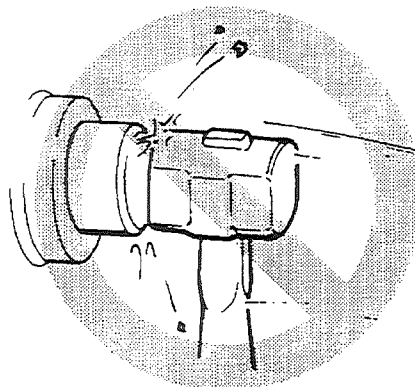

■ Pressure Air Can Cause Personal Injury

When using pressure air for cleaning purposes, clear area of bystanders, guard against flying chips, and wear personal protection equipment including eye protection.

Reduce compressed air to less than 200 Kpa (30 PSI) when using for cleaning purposes.



■ Disconnect Battery Ground Cable

Disconnect battery ground cable (-) before welding on machine or making adjustments on engine or electrical system.

For service batteries, be sure to see "Precautions for Servicing Batteries".

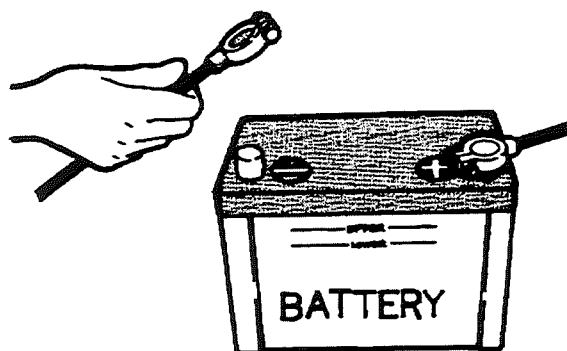

■ Check Tire Pressure

Explosive separation of tire and rim parts can cause serious injury or death.

When inflating tires, use clip-on chuck and extension hose long enough to allow you to stand to one side and not in front of or over tire assembly. Use safety cage if available.

Wear safety glasses, ear plug and other safety equipment.

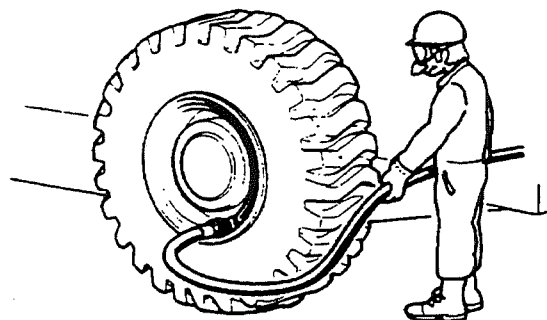
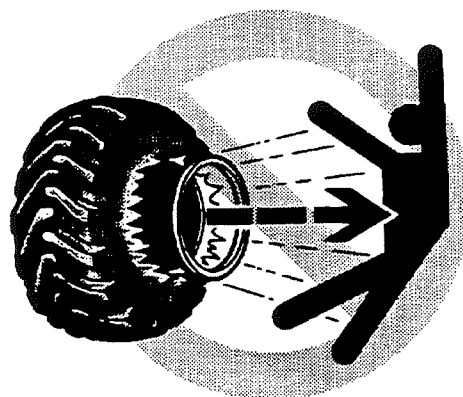

■ **Tire Maintenance**

Tire and rim servicing can be dangerous, and should be done by well trained personnel using proper tools and procedures. Call your authorized dealer or qualified repair service to inspect rim and tire assembly and make necessary repairs.

For handling tires, be sure to see “**Precautions for Tire Maintenance**”.



4. After Maintenance

■ After Maintenance

- After maintenance, idle engine at low speed to check for oil or coolant leakage.
- Slowly move control levers to check operation.
- Increase engine speed to check for oil or coolant leakage.
- Move control levers to check that function of them.

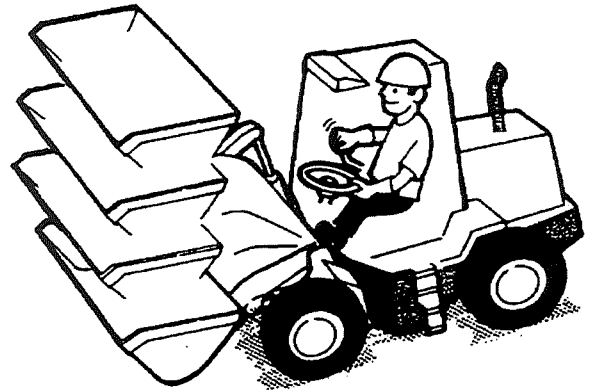

■ Dispose of Waste Properly

Improperly disposing of waste can threaten environment and ecology. Potentially harmful waste used with your machine include such items as oil, fuel, coolant, brake fluid, filters, and batteries.

Use leakproof containers when draining fluids. Do not use food or beverage containers that may mislead someone into drinking from them.

Do not dump waste onto ground, down drain, or into any water source.

Air conditioning refrigerants escaping into air can damage Earth's atmosphere. Government regulations may require certified air conditioning service center to recover and recycle used air conditioning refrigerants.

Inquire on proper way to recycle or dispose of waste from your local environmental or recycling center, or from your authorized dealer.

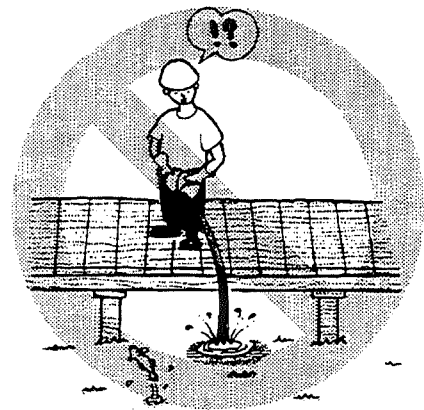

■ Contact Your authorized Dealer for Repair

Difficult repair, when conducted incorrectly, will cause unexpected accidents.

Contact your authorized dealer for repair according to instructions shown in manual.



OPERATION

00001

00002

00003

00004

00005

00006

00007

00008

00009

00010

00011

00012

00013

00014

00015

00016

00017

00018

00019

00020

00021

Names of Components

■ Appearance of Machine

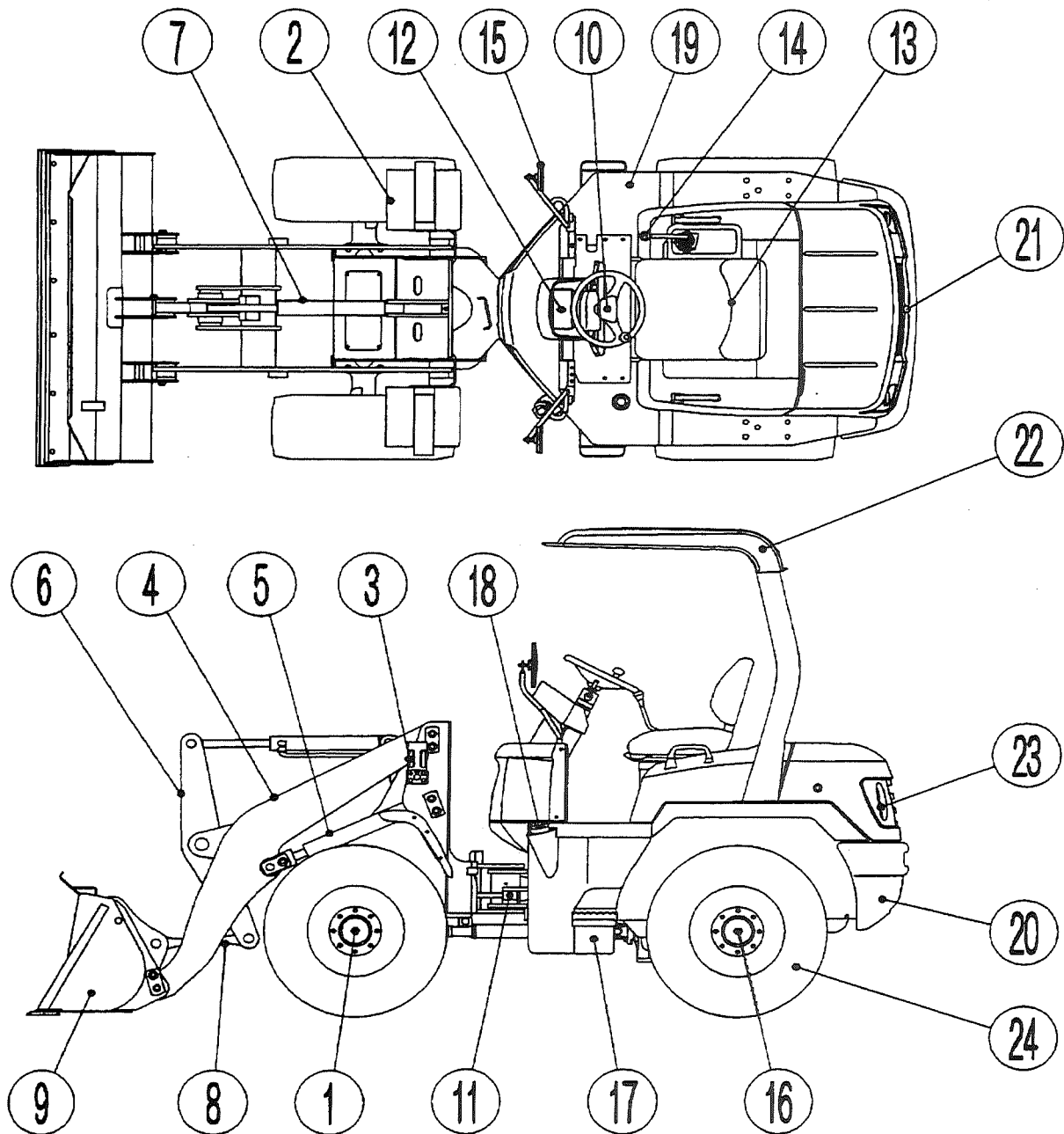

● Front Frame and Working Device

- 1. Front Axle
- 2. Front Fender
- 3. Head Light/Front Indicator
- 4. Lift Arm
- 5. Lift Cylinder
- 6. Bellcrank
- 7. Tilt Cylinder
- 8. Bucket Link
- 9. Bucket

● Operator Seat

- 10. Steering Wheel
- 11. Steering Cylinder
- 12. Meter Panel
- 13. Operator Seat
- 14. Working Device Control Lever
- 15. Sideview Mirror

● Rear Frame

- 16. Rear Axle
- 17. Fuel Tank
- 18. Fuel Filler Port

- 19. Hydraulic Oil Tank
- 20. Weight
- 21. Drawbar Pin
- 22. Canopy
- 23. Rear Indicator/Back-up Light/Brake Light/Tail Light
- 24. Tire
- L3-2: 10-16.5-4PR
- L4-2: 12.5/70-16-6PR
- L5-2: 15.5/60-18-8PR
- L6-2: 15.5/60-18-8PR

Operator's Station

Functions and controls necessary for operation are covered.
Read and fully understand all functions and controls.

■ Meter Panel

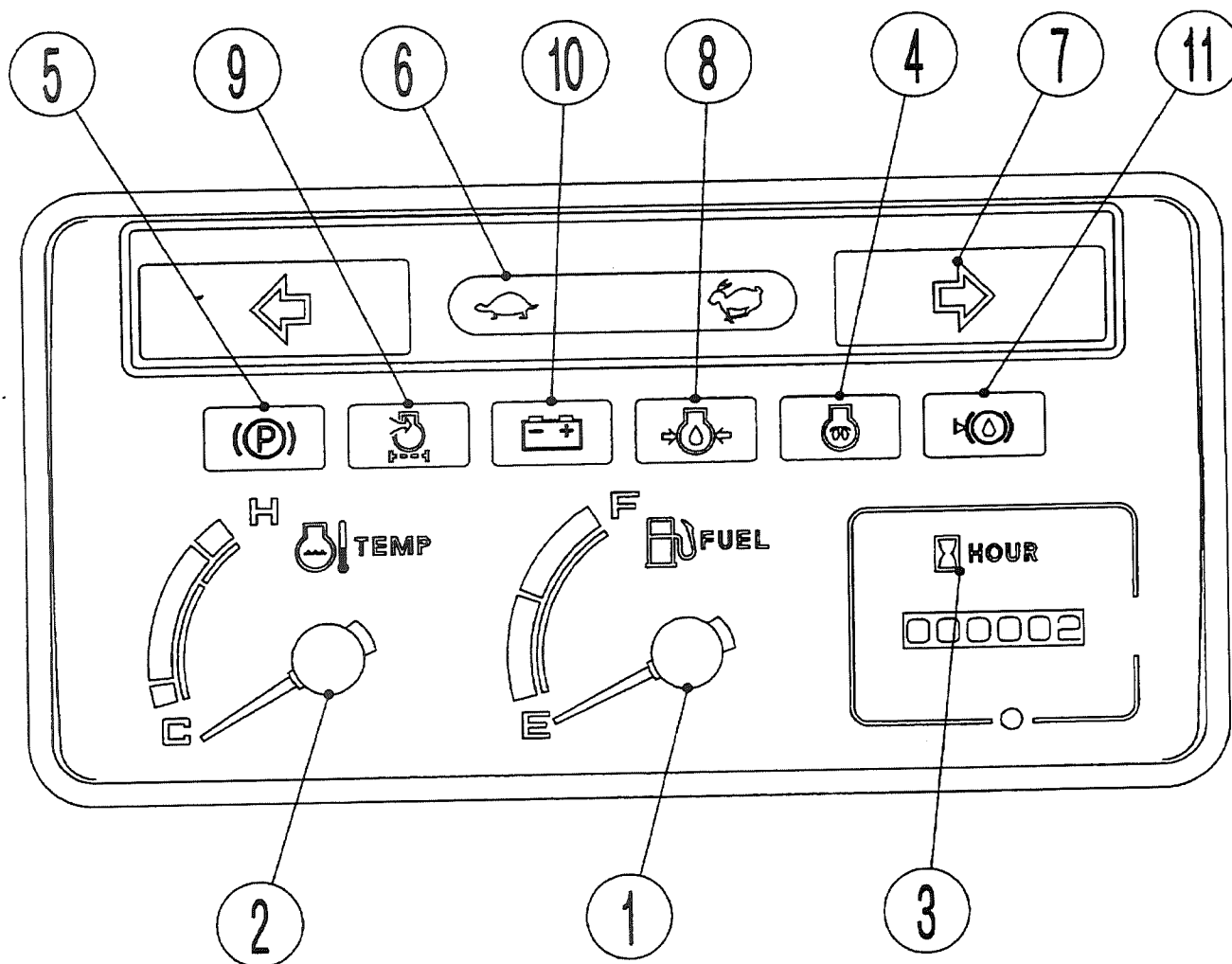

● Meters

1. Fuel Gauge
2. Engine Coolant Temperature Gauge
3. Hour Meter

● Pilot Lamps (Work Indicator Lamps)

4. Engine Pre-heat Indicator
5. Parking Brake Indicator
6. Speed Shift Indicator
7. Turn Signal Indicator

● Monitor Lamps (Warning Indicator Lamps)

8. Engine Oil Pressure
9. Air Cleaner
10. Alternator (Charge)
11. Brake Oil

● **Meters**

① **Fuel Gauge**

Fuel gauge indicates amount of fuel in fuel tank.

	L (gal)	
Tank capacity	F level	E level (remainder)
L3-2	33 (8.7)	6 (1.6)
L4-2	50 (13.2)	11(2.9)
L5-2	50 (13.2)	11 (2.9)
L6-2	50 (13.2)	11 (2.9)

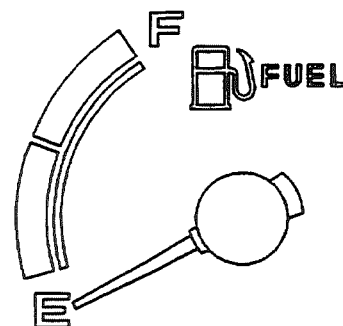

E (Empty): Indicates that fuel tank is empty.

(A little fuel remains.)

F (Full): Indicates that fuel tank is full.

NOTE

When gauge approaches E, refill tank with light oil as soon as possible.

② **Engine Coolant Temperature Gauge**

IMPORTANT

Don't stop engine immediately when overheated. Coolant temperature may be rapidly heightened to cause seizure. Run engine at low idle until coolant temperature is decreased. Don't refill radiator with cold coolant, otherwise engine may be damaged.

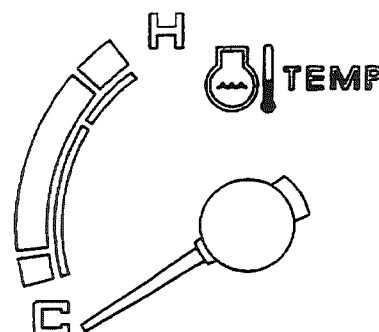

Engine coolant temperature gauge indicates temperature of engine coolant.

● **If Gauge Stays in White Zone:**

Temperature of engine coolant is in operating range.

● **If Gauge Reaches Red Zone (H):**

It indicates that engine is overheated. Immediately stop the work, then run engine at low idle, and wait until gauge returns to white zone. After coolant temperature is lowered, stop engine and check cooling system. (Quantity of coolant is not full, fan belt is loosened, radiator is clogging, water leaks, etc.)

③ Hour Meter

Hour meter indicates operating time of engine. Set your checking and maintenance intervals based on time data of hour meter. It is recommended to supply lubricant at shorter intervals when machine is to be operated under hard working conditions or in humid locations.

- When starter switch is in "ON" position and one hour elapses, indicator on hour meter advances by 1, even if machine does not operate.
- Function of hour meter can be checked by monitoring flashing of green, operational status indicator lamp (A) below meter. Check meter or electrical system if operational status indicator lamp (A) is not flashing.

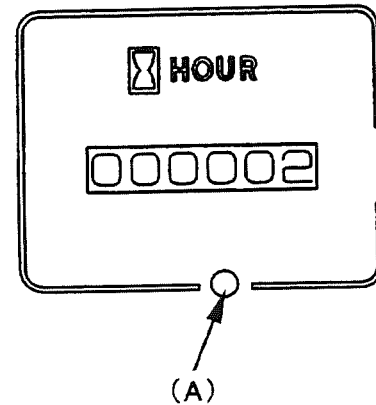

● **Pilot Lamps (Work Indicator Lamps)**

④ **Engine Pre-heat Indicator**

Indicator comes on when starter switch is in **HEAT** (preheating) position. It indicates that glow plug is operating. Preheating circuit is turned off and this indicator goes out automatically after approx. 5 seconds.



⑤ **Parking Brake Indicator**

This indicator comes on when parking brake is applied. When you drives the machine, release the parking brake and make sure that this indicator is off.



⑥ **Speed Shift Indicator**



This indicator comes on when speed is at work mode (1st speed is fixed).



This indicator comes on when speed is at automatic shift mode (FORWARD/BACKWARD 1st to 2nd).

⑦ **Turn Signal Indicator**

This indicator shows turn signal is flashing. Move turn signal lever forward (when turning to the left), and left indicator flashes. Move the turn signal lever backward (when turning to the right), and right indicator flashes. When the hazard light switch is "ON", both of the turn signal indicators flash at the same time.

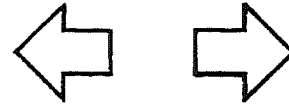

● Monitor Lamps (Warning Indicator Lamps)

IMPORTANT

When trouble occurs in respective sections shown on monitor, sensor is activated and indicator light comes on. When indicator light comes on, stop engine immediately or run it at low idle and take appropriate corrective action.

⑧ Engine Oil Pressure

This indicator lamp shows that engine lubricant oil pressure is low. When oil pressure is low, monitor lamp is turned on.

When indicator lamp comes on during operation, engine seizure may occur. Stop operation immediately, move machine to safe place and then stop engine to inspect it.

(Inspection)

- Check engine oil level. If it is not sufficient, supply engine oil.
- Check oil filter element for clogging. If the replacement period has passed, replace the oil filter element and oil.
- Check for oil leakage. If it is found, make repairs.
- Check sensor and oil filter switch for trouble.

If indicator lamp is still ON, contact with your authorized dealer.

NOTE

Indicator lamp comes on when starter switch is set to the "ON" or "HEAT" position. After engine start, indicator lamp goes out if oil pressure is proper.

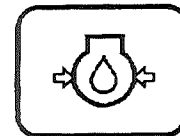

⑨ Air Cleaner

When air cleaner elements are clogged, this indicator lamp comes on.

When indicator lamp comes on during operation, stop operation immediately, move machine to safe place and then clean or replace elements.

Refer to “**Cleaning and Check of Air Cleaner Element**” and “**Replacement of Air Cleaner Element**”.

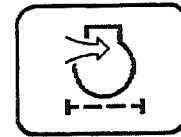
**NOTE**

Indicator lamp comes on when starter switch is set to “ON” or “HEAT”. After engine start, indicator lamp goes out if machine is normal.

⑩ Alternator (Charge)

This indicator lamp comes on if trouble has occurred in charge system during engine rotation.

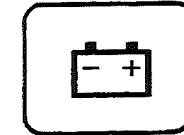

When indicator lamp comes on during operation, stop operation immediately, move machine to safe place and then stop engine.

(Inspection)

- Check fan belt for looseness or damage.
- Check alternator, relay and wires for looseness.

If indicator lamp is still ON, contact with your authorized dealer.

NOTE

Indicator lamp comes on when the starter switch is set to “ON” or “HEAT”. After engine start, indicator lamp is normal if it goes out as engine rotary speed is increased.

① Brake Oil

When oil level is low in brake reservoir tank, indicator lamp comes on.

If this lamp comes on during traveling, brake may not function. Stop machine immediately.

Check brake piping (from master cylinder to reduction) for oil leakage.

If no trouble is found, refill brake reservoir tank with brake oil. (Refer to "Applicable Oil List".)

Refer to "**Check of Oil Level in Brake Oil Tank and Supply**".

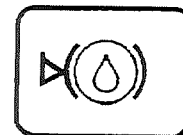

■ Function Test of Monitoring System

Indicator bulb blowout and operational checks can be carried out by setting starter switch to "ON".

- Set starter switch to "ON", and all the monitor lamps come on.
Keep key at the "HEAT" position, and engine pre-heat lamp ④ goes out after approx. 5 seconds to show that preheating is completed.
- Parking brake lamp ⑤ keeps ON until parking brake is released.
- If there is no problem, all monitoring lamps go out when engine has started.
- When a monitoring lamp does not come on (the bulb is not blown out), contact with your authorized dealer.

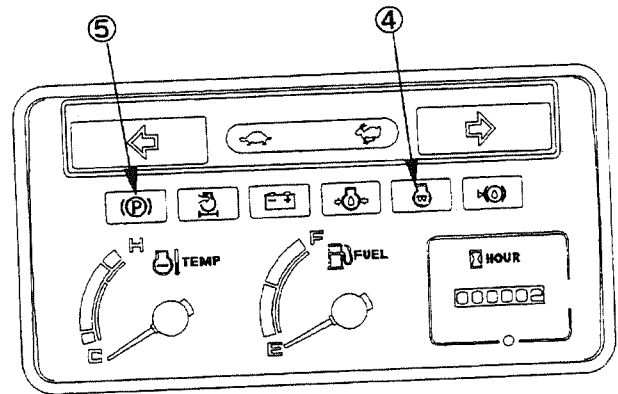

NOTE

Engine pre-heat pilot lamp ④ does not come on when starter switch is at the "ON" position.

■ Starter Switch

IMPORTANT

Preheating is completed in approx. 5 seconds, glow plugs are automatically turned off and engine pre-heat pilot lamp is also turned off. Right after preheating is completed, turn key to the "START" position to start engine. It is not necessary to use glow plug when the atmospheric temperature is normal. Don't keep key in the "START" position for 20 seconds or more, otherwise related parts will be damaged.

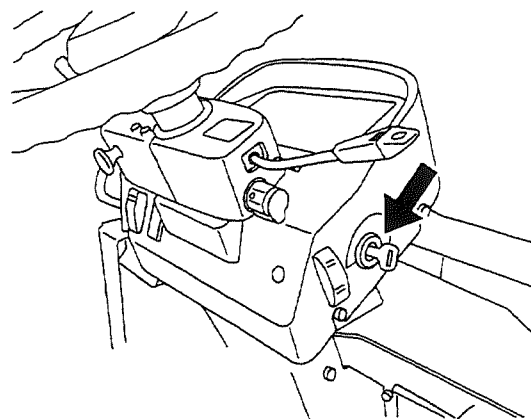

This switch is used to start and stop the engine.

- OFF** Key can be inserted and removed and machine's electrical circuits are turned off.
- Set the key to this position when you wish to stop engine.
- ON** Electrical circuits are operational in the machine.
- START** This is engine start position. When engine has started, release key. Key automatically returns to "ON" position.
- HEAT** This position is used when ambient temperature is low and engine is difficult to start. When switch is at "HEAT" position, glow plug operates and engine pre-heat lamp comes on. Release key, and it automatically returns to "OFF" position.



■ Parking Brake Switch

WARNING

- If parking brake is applied while machine is traveling, machine stops suddenly. Don't use parking brake instead of the service brake except in emergency.
- When engine has stopped during traveling, parking brake is applied and so the machine stops suddenly. It is very dangerous.
- When you park machine or have to leave it, be sure to apply parking brake.

This switch operates and releases parking brake.

ON Press switch upward (**ON**), and parking brake is applied and parking brake pilot lamp comes on.

OFF Press switch downward (**OFF**), parking brake is released and parking brake pilot lamp goes out.

RESET When parking brake is applied and engine starts, press switch further downward (**OFF**). Parking brake is released and parking brake pilot lamp goes out.

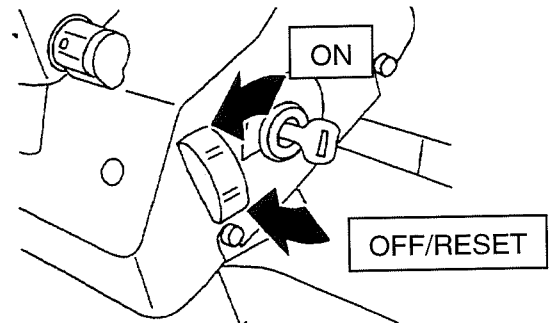
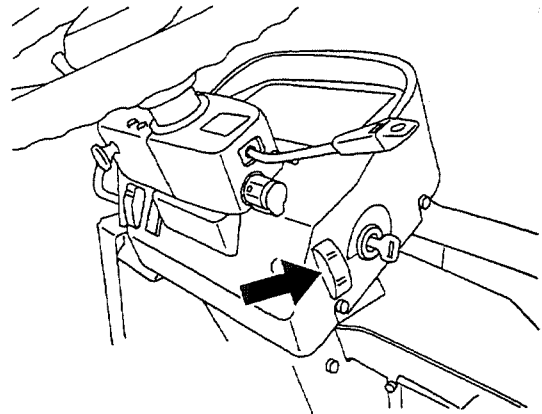

NOTES

- Engine can start whether parking brake switch is **ON** or **OFF**.
- After engine has started, unless parking brake switch is set to "RESET", parking brake is not released.
- Parking brake is released by oil pressure. Under engine stop condition, parking brake cannot be released even if switch is set to "OFF".

■ Light Switch

This switch has two rotary selection positions.

OFF

..... Lights go out.



..... Side lights, tail lights, gauge lights and meter lights come on.

(First Position)



..... Rest of the lights (head lights) come on in addition to those of First Position.

(Second Position)

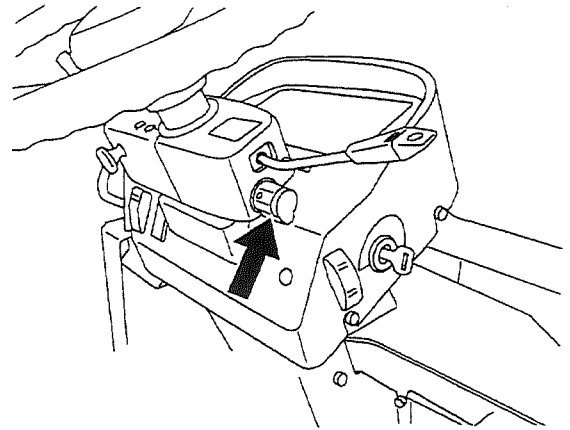

■ Turn Signal Lever

Use the turn signal lever to deliver signals when turning to left or right and when changing lines.

Moving lever forward or backward makes the turn signal light and turn signal indicator flash.

Move lever forward (in direction of arrow ①) to turn to left, or backward (in direction of arrow ②) to turn to right.

The lever does not return to its initial position automatically. Return lever by hand.

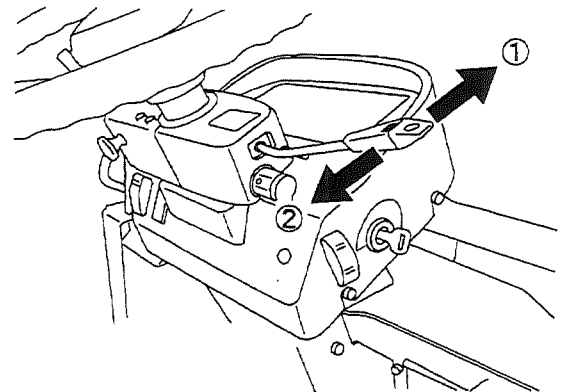

■ Hazard Light Switch

When this switch is pulled rightward, it comes to **ON** and all the signal lights and the turn signal indicators will flash.

Use this switch when your machine has stopped urgently on the roads because of puncture or other troubles.

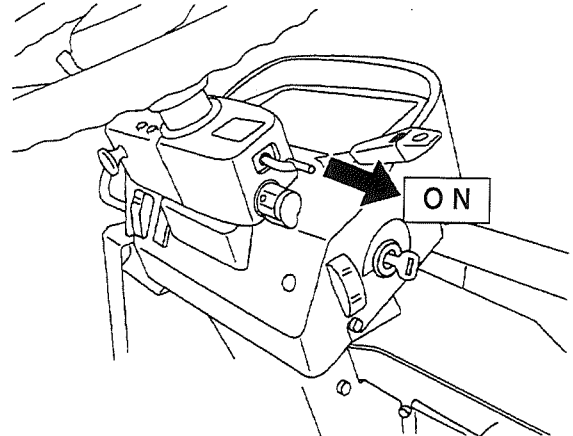

■ Horn Switch

Push center of handle, and horn sounds.

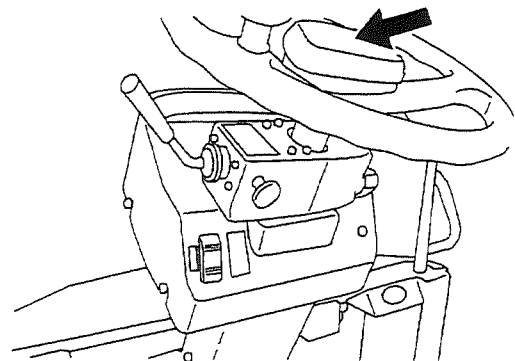

■ Fuse Box

IMPORTANT

- Before replacing fuses, be sure to turn off power (starter switch OFF). Before replacing hazard fuse, disconnect the negative terminal of battery.
- Don't use a fuse exceeding the specified capacity, and wire, silver paper or any other materials, otherwise an electric wire will be overheated and burned.
- If a new fuse blows out right after replacement, there are other problems. Contact with your authorized dealer.

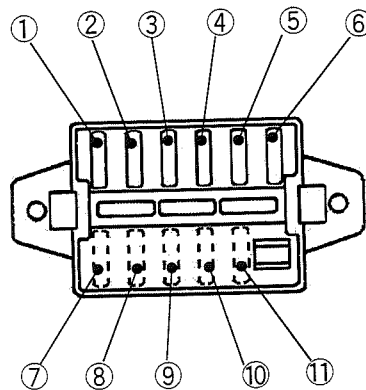
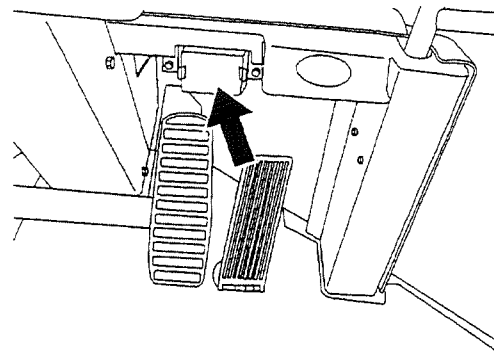

Fuses prevent excessive current from flowing into the electrical circuit and protect electric parts and wiring from damage. Remove fuse box cover, and you will see fuses.

If a fuse has blown out, examine and eliminate its cause and then replace it with a new fuse having the same capacity.

■ Fuse Capacity and Circuit Name

No.	Fuse Capacity	Circuit Name
1	15A	HST [F], [R] solenoid/HST [1st (medium speed) fixed] solenoid/Parking brake solenoid/Relay [3], [4]/Back-up light/Back buzzer
2	30A	Head light/Turn signal light/Meter panel illumination light/Tail light/Flasher unit
3	10A	Meter panel monitor light/Coolant temperature gauge/Fuel gauge/Hour meter/Relay [1]. [2]
4	15A	Stop light/Horn
5	10A	Auto leveler proximity switch/Control valve tilt detent
6	10A	Glow lamp timer/Fuel pump/Engine stop solenoid
7	-	Heater (Option)
8 to 11	-	Option power supply

■ Speed Shift Lever

WARNING

Before parking, leaving or repairing machine, set the shift lever "N" (Neutral) and lock it.

The lever of machine changes direction (forward/backward).
Speed step is automatically changed.

F (Forward LOW & AUTO):

..... Push the lever forward, and machine move forward.

N (Neutral):

..... When lever is at "Neutral", the machine does not move.

R (Reverse LOW & AUTO):

..... Pull lever backward, and e machine moves backward.

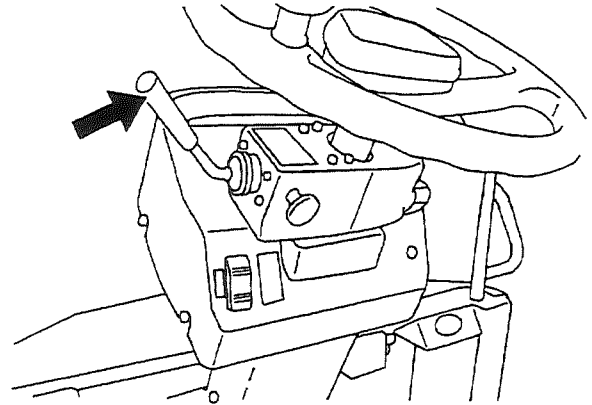

■ Safety Lock (for Shift Lever)

Safety lock locks the shift lever.

Lock: Push button forward, and the shift lever is locked.

Unlock: Pull button backward, the safety lock is released.

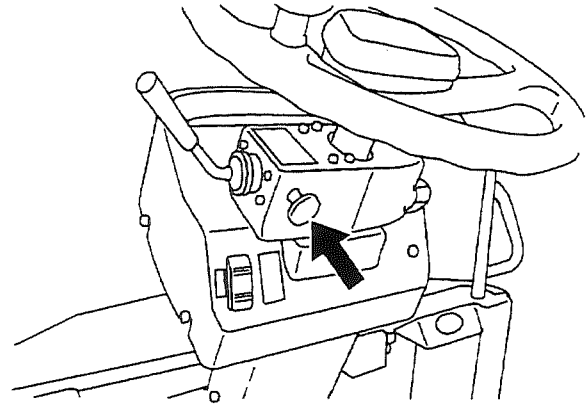

NOTE

When shift lever is at other ones except "N" (Neutral), safety function works and so the engine does not start.

■ Travel Mode Selector Switch

This switch is used to select the speed mode of machine.

LOW ... Push the switch to "**LOW**", and work mode (1st speed fixed) is selected.



AUTO ... Push switch to "**AUTO**", and work mode is canceled and automatic travelling mode is selected. Speed is automatically shifted.

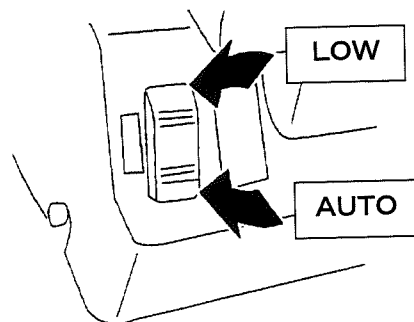
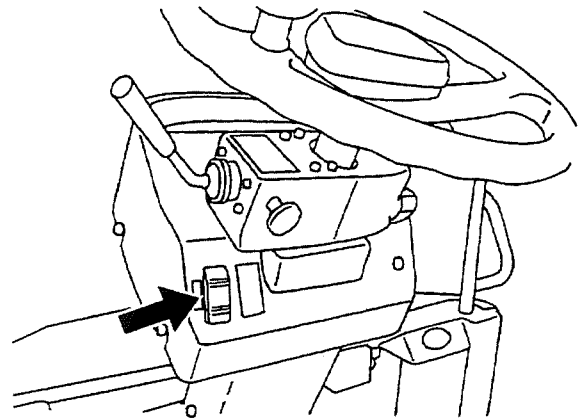

- Working Device Control Lever
- Control of Lift Arm

! WARNING

Don't place lever at the "FLOAT" position when bucket is loaded. If lever is at "FLOAT", dropping speed cannot be controlled.

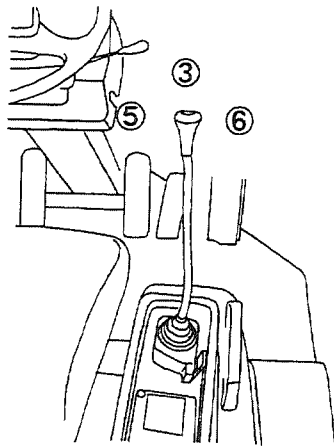
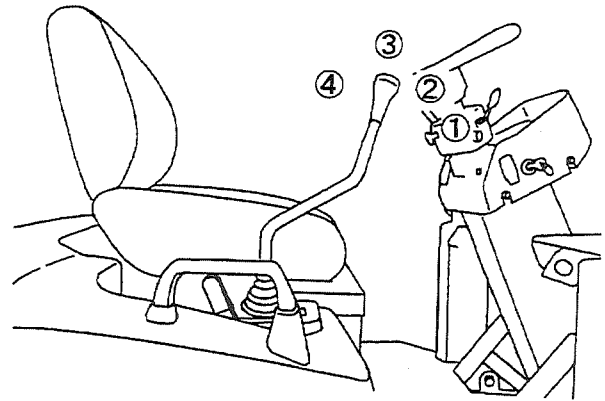

- ① **FLOAT** Push lever fully forward, it stops at "FLOAT" and lift arm moves freely with any external force remaining applied. Unless lever is held at "FLOAT", it returns to ③ "NEUTRAL" when released.
- ② **LOWER** Push lever forward, and lift arm is lowered. Release lever, and it returns to ③ "NEUTRAL".
- ③ **NEUTRAL** Lift arm and bucket remain at stop position. When you have stopped operation of "LOWER", "RAISE", or "TILT", "DUMP", lever returns to this position.
- ④ **RAISE** Pull lever backward, and lift arm is raised. Release lever, and it returns to ③ "NEUTRAL".

● Control of Bucket**⑤ TILT-BACK**

..... Pull the lever to left, and bucket is tilted backward (TILT-BACK). Release lever, and it returns to ③ "NEUTRAL".

Note:..... When lever is released within auto leveler operating range, bucket remains at TILT-BACK position. When bucket is at preset angle, lever automatically returns to "NEUTRAL".

⑥ DUMP..... Push lever to right, and bucket is tilted forward (DUMP). Release lever, and it returns to ③ "NEUTRAL".

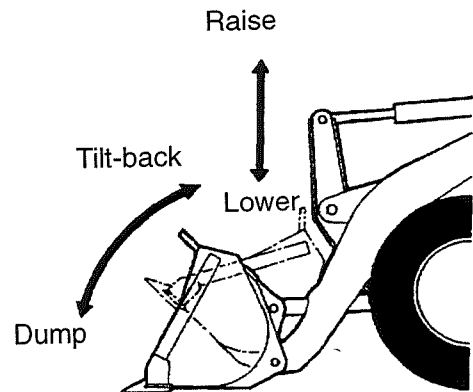
**NOTE**

Lift arm and bucket can be operated at same time. For example, as raising lift arm, bucket is tilted backward. Such combined operation is possible.

■ **Safety Lock (for Working Device Control Lever)**

! WARNING

Before parking, leaving or repairing machine, put bucket on ground and lock working device control lever. If you touch unlocked working device control lever carelessly, a serious accident may occur.

This is a locking device for working device control lever.

LOCK: Push safety lock lever forward, and working device control lever is locked.



UNLOCK: Pull safety lock lever backward, and working device control lever is unlocked.

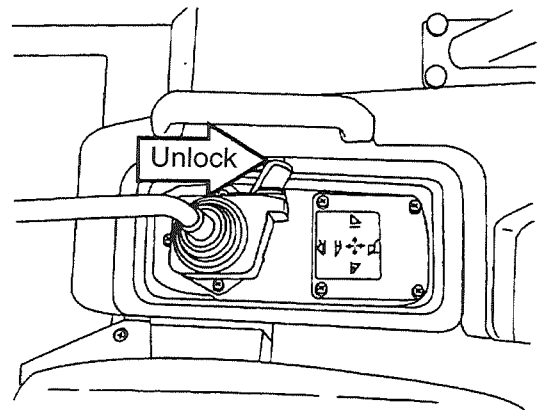
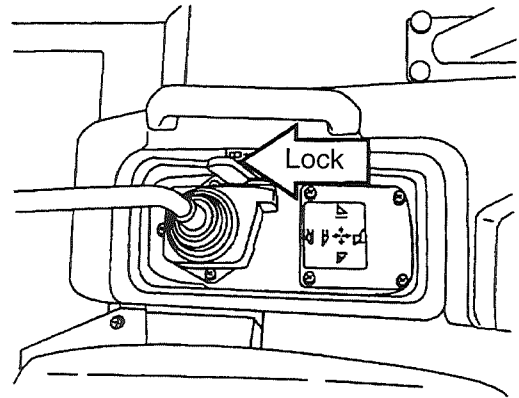

■ **Safety Bar**

! WARNING

- Before maintenance, transporting or lifting machine, fix front and rear frames with safety bar.
- Before general traveling, make sure that safety bar is set to the "UNLOCK" position.

This device locks front and rear frames not to bend them when repairing, transporting or lifting machine.

LOCK: Connects front and rear frames with safety bar and fixes them with pins.



UNLOCK: Sets front frame in its housing position and fixes it with pins.

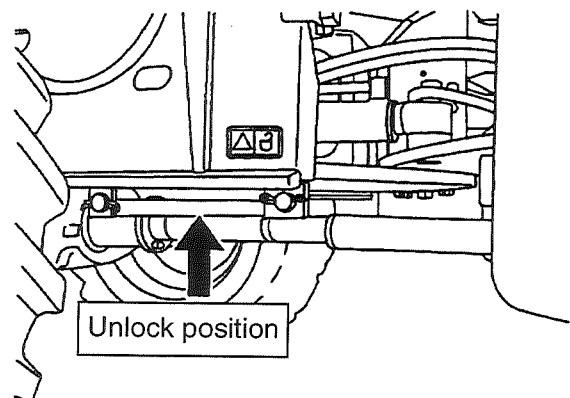
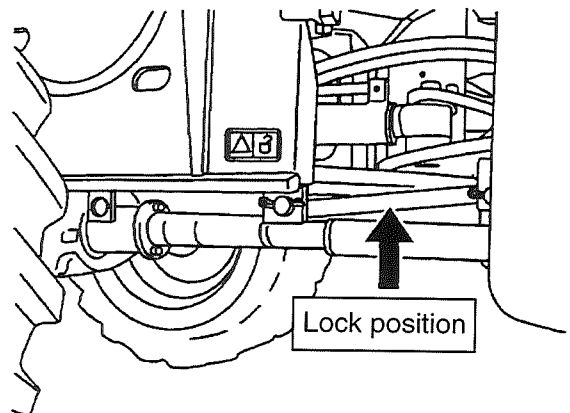

■ Brake Pedals

! WARNING

- Don't depress brake pedal repeatedly more than necessary.
- Don't put your foot on brake pedal if not necessary.

Step on brake pedal to stop machine.

Brake pedal is interlocked with inching valve of HST pump. When brake pedal is stepped on a little, HST pump returns to "NEUTRAL". Braking function of HST and operation of service brake will stop machine more powerfully.

Step on brake pedal, and HST will return to neutral status whether shift lever is in forward or backward position. Therefore, motive power of engine can be concentrated on working equipment when excavation, loading, or other working speed is required.

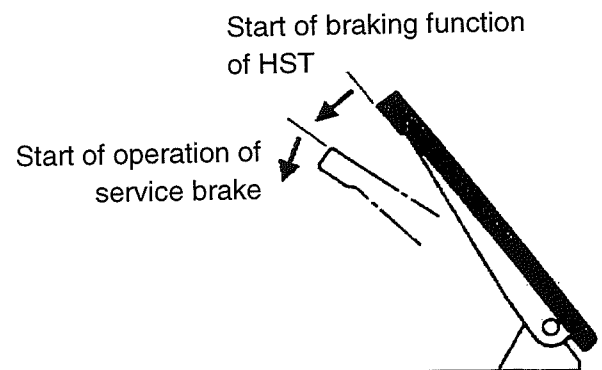
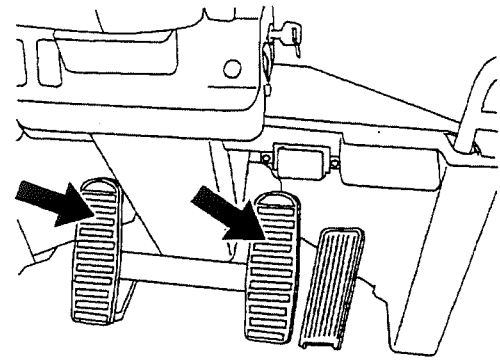

■ Accelerator Pedal

Depress to increase engine speed.
Release to decrease engine speed.

Traveling speed of machine and operating speed of working device are controlled by accelerator pedal. Avoid sudden acceleration.

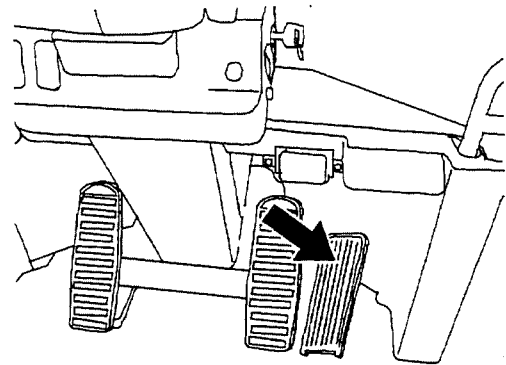

■ Adjustment of Operator's Seat

⚠ WARNING

- It is dangerous to adjust the seat while you are operating. Adjust it before starting the machine.
- Adjust the seat position so that you can depress all pedals completely while pressing your back against the back of operator's seat.

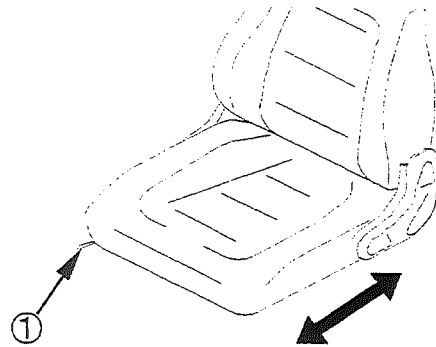

● Back-and-forth Adjustment

Seat can be adjusted back and forth. Move adjusting lever [1] to right (outward), and, after setting seat in the desired position, release lever and fix seat.

■ Seat Back Pocket

A pocket to put operation manual in is provided on rear side of back of operator's seat. Keep operation manual in this pocket for future reference.

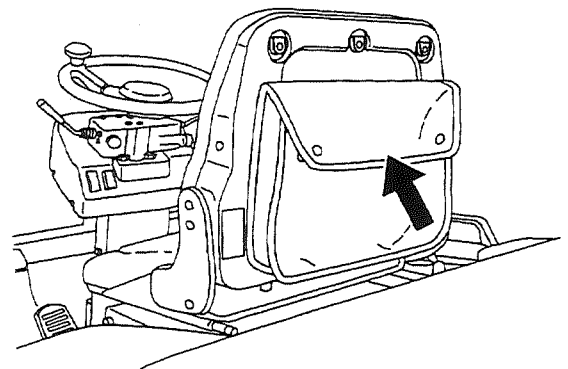

■ **Fuel Tank Cap (with Lock)**

Fuel tank filler port is equipped with lock. Open and close cap with starter switch key.

● **When opening cap**

1. Insert key. Insert key to its root securely and then operate it. If key is operated in unstable condition, it may be broken.
2. Turn key counterclockwise in 90° to unlock cap, and cap can be opened.

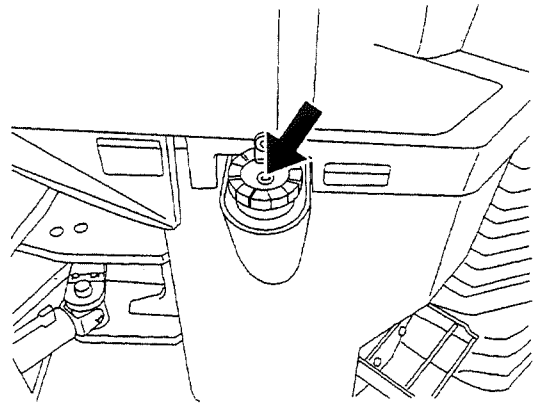

● **When closing cap**

1. Screw in cap.
2. Turn key clockwise in 90° to lock cap and then remove key.

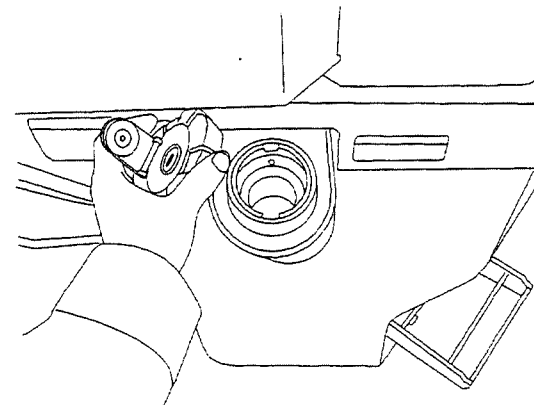

■ **Opening and Closing of Engine Hood**

● **When opening engine hood**

1. Turn lock key ① to release position with starter switch key.
2. Press lock key ①, and engine hood ② is slightly lifted.
3. Hold handle of engine hood ② and tilt engine hood ② backward.

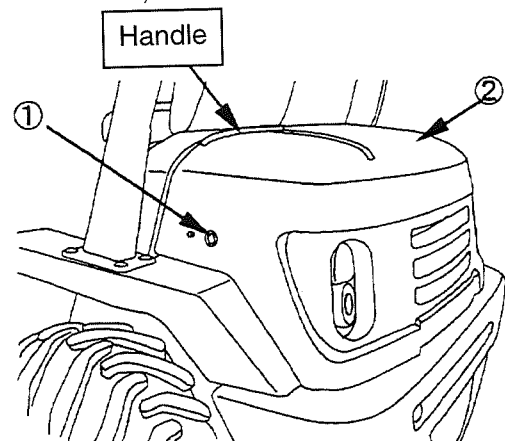

● **When closing engine hood**

1. Slowly close engine hood ② and press it until a click sound is heard.
2. After closing engine hood ②, set lock key [1] to locking position to lock engine hood ②.

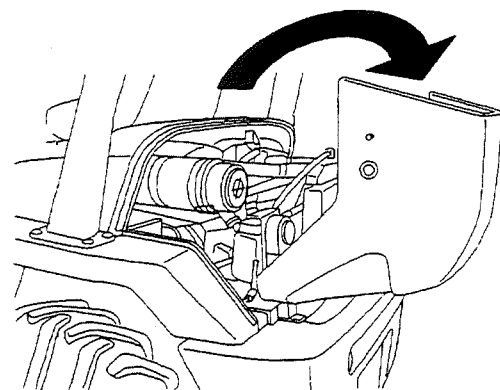

NOTE

Firmly close and lock hood except inspection time to prevent theft and mischief.

■ **Sideview Mirrors**

Adjust sideview mirrors to see rear of machine most properly.

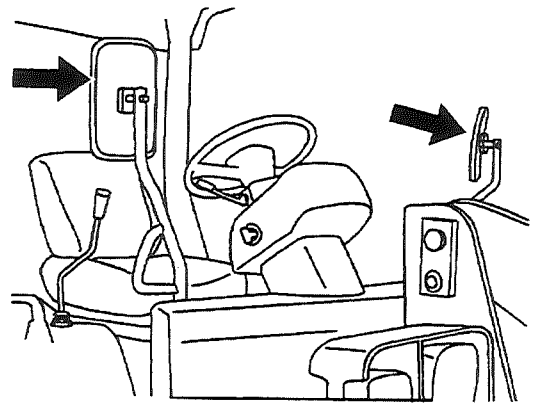

■ **Drawbar Pin**

When towing other machine or when fixing machine for transportation, use pin provided at rearmost of machine.

Drawbar pin can be removed if ring pin is removed by removing its ring.

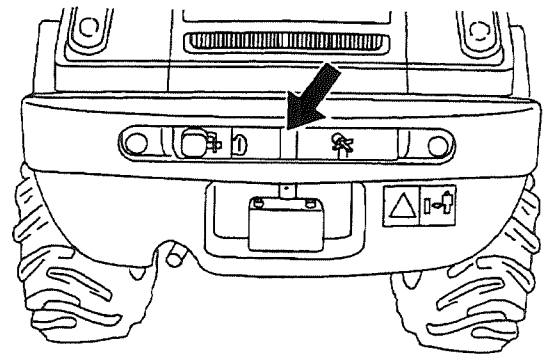

■ **Back Buzzer**

Set shift lever to "Reverse" (R), and back buzzer sounds. When you are driving machine, check safety at rear of machine carefully and then reverse machine.

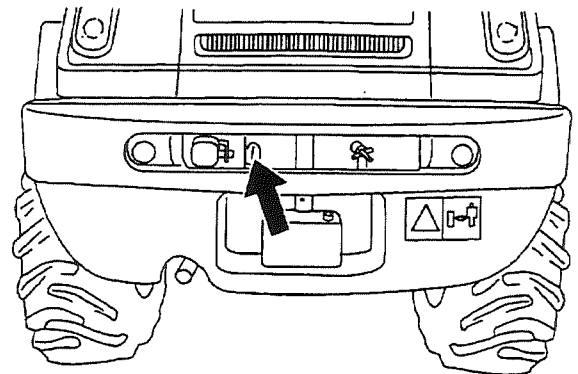

■ **Back-up Light**

Set shift lever to "Reverse" (R), and back-up light comes on. When you are driving machine, check safety at rear of machine carefully and then reverse machine.

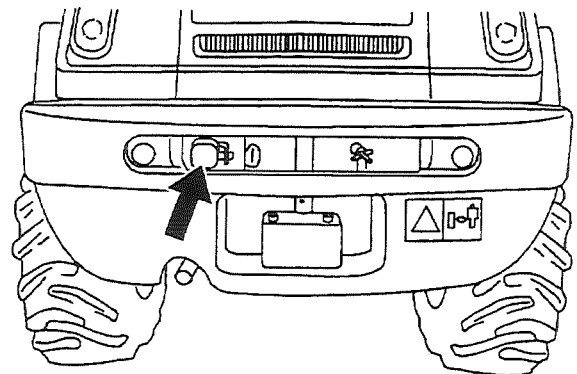

■ **Bucket**

Bucket is equipped with leveler plate. Use leveler plate as a standard of bucket angle for operation.

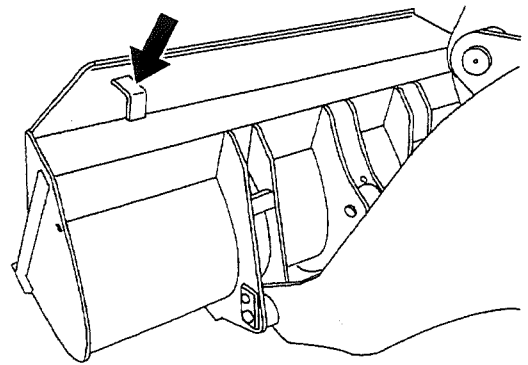

■ **Bucket Auto Leveler**

After dumping bucket contents, set working device control lever to "TILT-BACK". When bucket is tilted to preset angle, working device control lever returns to "NEUTRAL" automatically and "TILT-BACK" stops.

Then, when lift arm is put on ground, bucket is horizontal if set angle is horizontal.

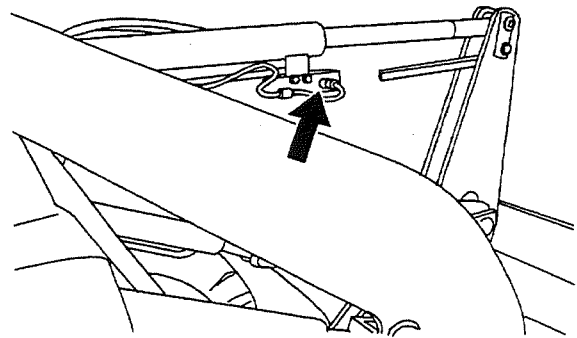

Cab Operation

■ Machine Equipped with Cab (Option)

The following equipments are added to a machine with cab.

● Door

You can get on/off cab from right or left door. There is working device control lever near right door and so you should use left door when getting on/off.

The right and left doors can be kept open. Push door to engage U bolt ② with latch ①, and door is locked. To unlock door, pull lever ③ forward. Latch is disengaged and door is unlocked.

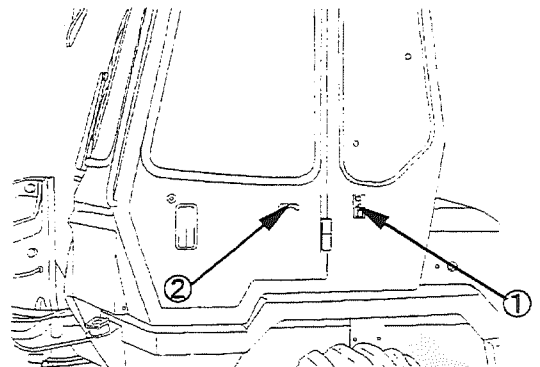
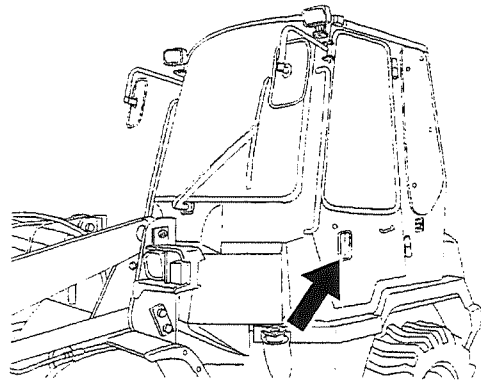
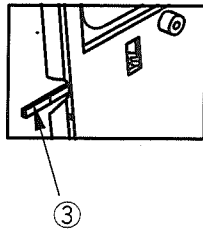

■ Quarter Glass

To open quarter glass, push it as pulling lever.

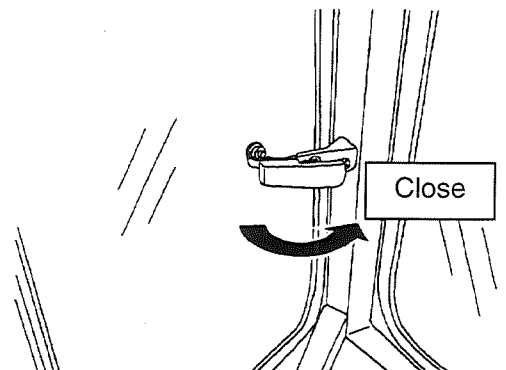
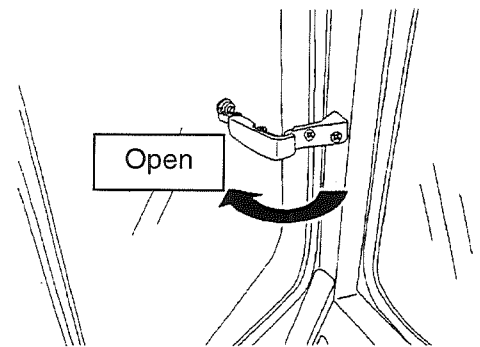

■ Panel Switches

① Front Wiper/Washer Switch

Turn switch clockwise to operate wiper.

- Stop
- (1st speed) Operates at low speed.
- (2nd speed) Operates at high speed.

Press switch to spout washer fluid.

② Rear Wiper

Turn the switch clockwise to operate wiper.

- Stop
- Operation

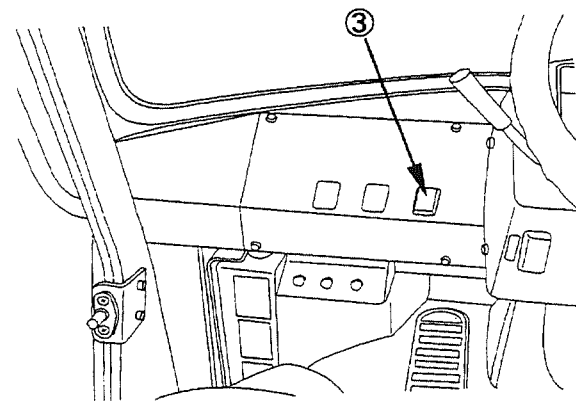
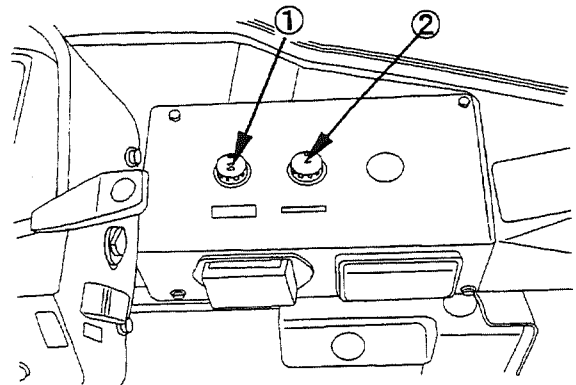

NOTE

Don't move wipers when window glass is dry.

③ Front Working Lights

! WARNING

Turn off front working lights when traveling on public roads.

Press switch to "ON" side (upward), and working lights come on at sides of cab. When working lights are ON, pilot lamp is ON. Press switch to "OFF" side (downward), and lights go out.

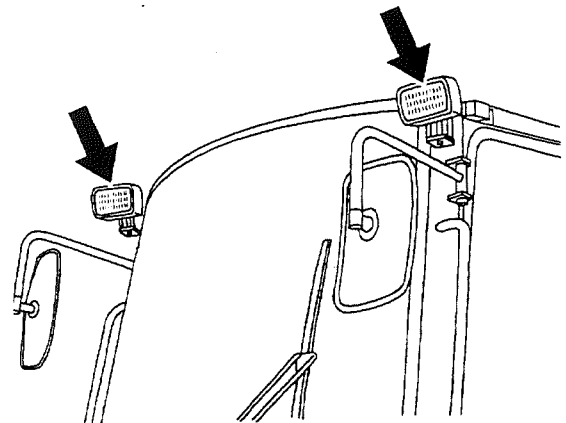

■ Fuse Box (Used Exclusively for Cab)

IMPORTANT

Before replacing fuses, be sure to turn off power (set starter switch to "OFF").

● Fuse Capacity and Circuit Name

NO	Fuse Capacity	Circuit Name
①	15A	Front wiper/washer
②		Radio
③		Front working lights
④		Room light
⑤		Rear wiper/washer
⑥		Optional power supply

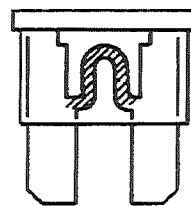
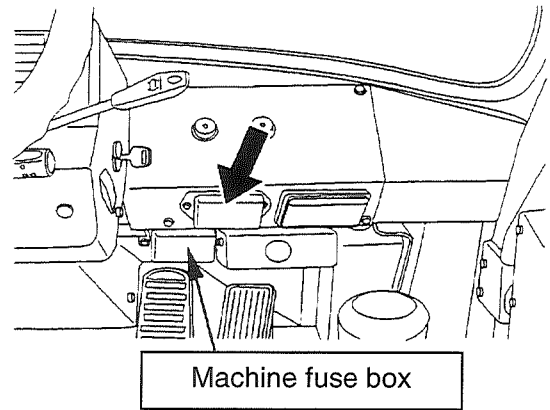

(Right)

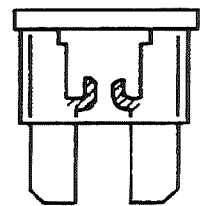

(Fuse has blown out.)

■ Ashtray

Ashtray is provided at right of operator's seat. Pull cover and use ashtray. If ashtray is not used, push it in.

 **CAUTION**

Clean ashtray before it is filled with stubs. If a stub drops to catch fire, it is dangerous.

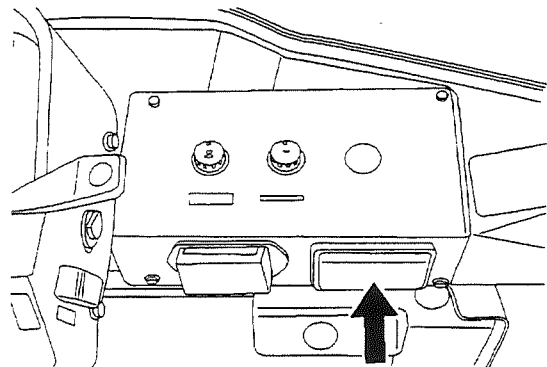

■ **Room Light**

Move slide switch to right, and room light comes on.

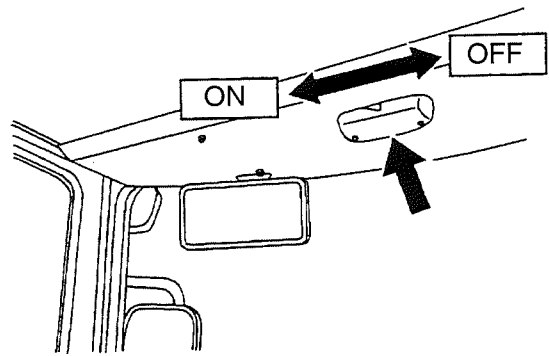

■ **Room Mirror**

Before operation, adjust the sideview mirrors and room mirror to see rear of machine most properly.

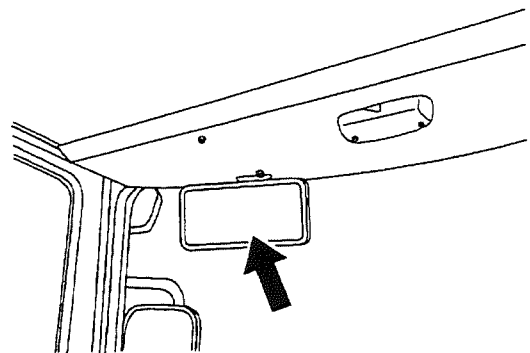

■ **Washer Tank**

The washer tank is provided at the rear right of operator's seat. Use a commercial washer fluid. In winter, keep the specified density to prevent freezing.

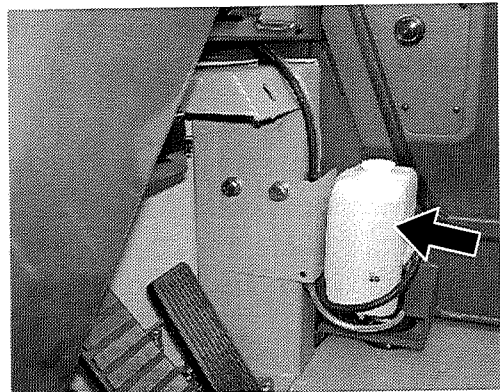

■ **Sideview Mirrors**

Adjust sideview mirrors to see rear of machine most properly.

Make adjustment by loosening nut ①. After adjustment, tighten nut securely. By loosening nut ②, stay opening width can be adjusted.

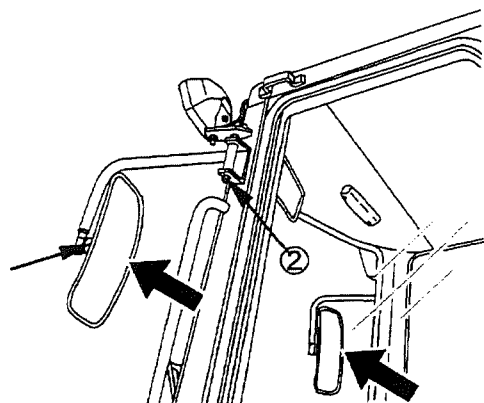

■ Heater (Option)

● Heater Switch

Heater switch is provided at lower right of meter panel. Turn knob clockwise to operate heater fan. Air flow can be adjusted by two steps.

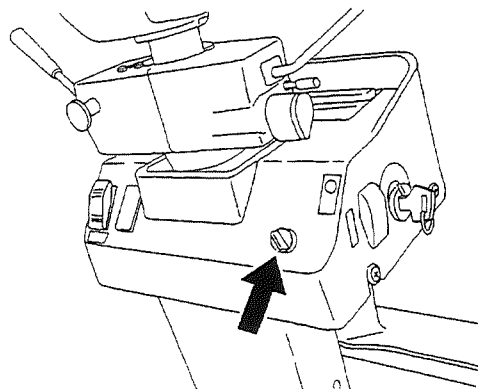

● Heater Unit

Heater unit is housed under operator's seat. By adjusting opening angle of cover, defroster (front glass) heater and foot heater can be adjusted.

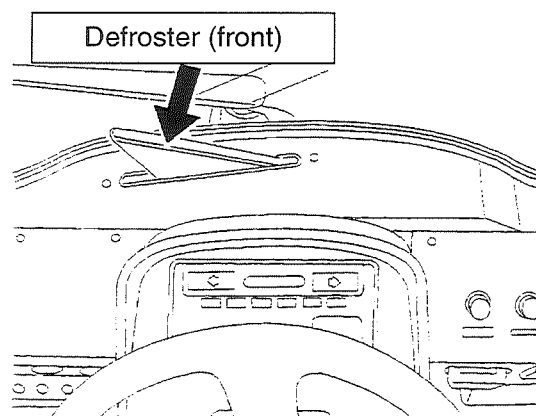
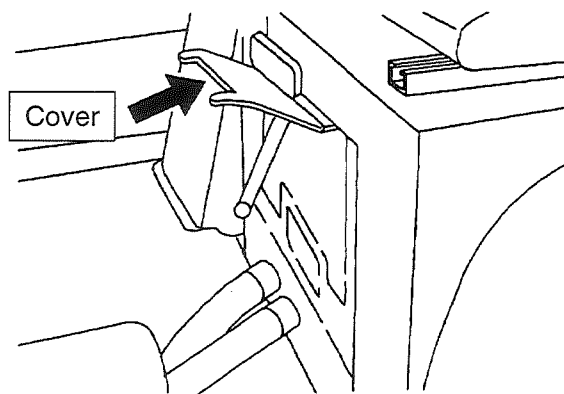

■ AM radio with clock (Option)

IMPORTANT

If panel is splashed with water, radio may malfunction. Handle radio very carefully.

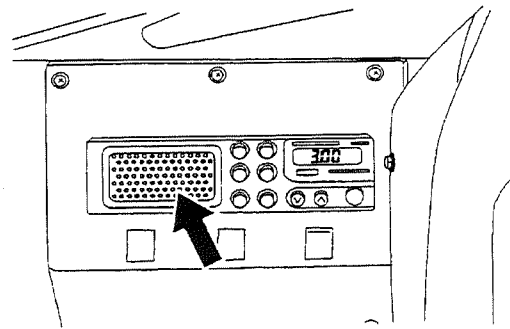

Radio is provided at front left of operator's seat.

■ Handling of Radio

● Setting the clock

Press ⬆ as pressing T-ADJ button, "minute" is changed. Press ⬇ to change "hour". Next, press RESET button, "minute" is changed to "00". Press DISP button, and frequency display appears.

● Programming of frequency

Press TUNE buttons ⬆ and ⬇ to select a desirable channel. Next, press program buttons ① to ⑥ for 2 seconds or more, program is set to pressed place.

● Changing the display

"Clock" and "Frequency" are displayed alternately by pressing DISP button.

● Adjustment of volume and tone quality

Turn ON/V button clockwise to increase volume. Turn ON/V button counterclockwise to decrease volume. Tone quality can be adjusted by turning TONE dial. Use button and dial as you like.

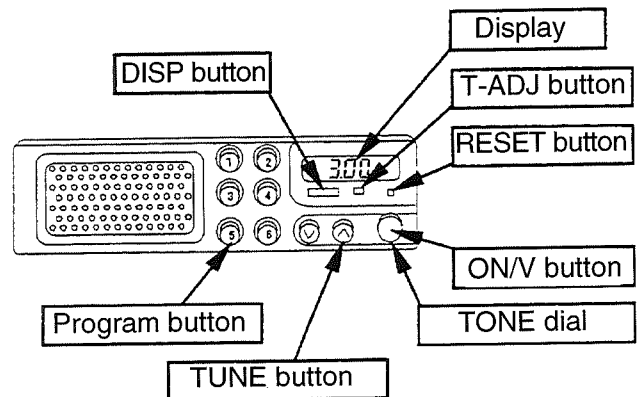

Engine Operation

Operating procedures from starting to stopping of engine are described here. Operating after engine start is described in "Operating Machine".

■ Before Starting Engine

1. Carry out daily checks before starting engine. Refer to "Periodic Maintenance/Daily" to the "MAINTENANCE" section.
2. Make sure that safety bar is set in unlock position.
3. Before starting engine, check positions of various levers, pedals, etc.
4. Adjust position of seat so that you can fully step on all pedals with your back firmly pressed against back rest of seat. When reversing, you may need to twist your body backward. In this case, maintain position of seat so that you can fully depress brake pedals.
5. Make sure that parking brake is applied.
6. Make sure that shift lever is locked in "N" (Neutral) position.
7. Make sure that working device is put on ground and working device control lever is locked.

NOTE

Unless the shift lever is at "N" (Neutral), the engine cannot start. Before starting engine, apply parking brake and set shift lever to "N" (Neutral).

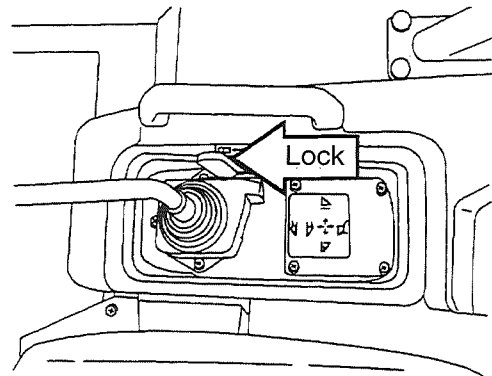
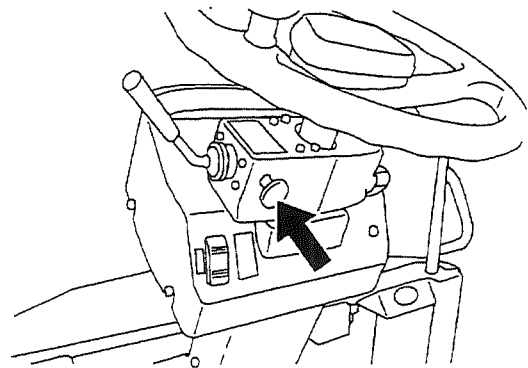
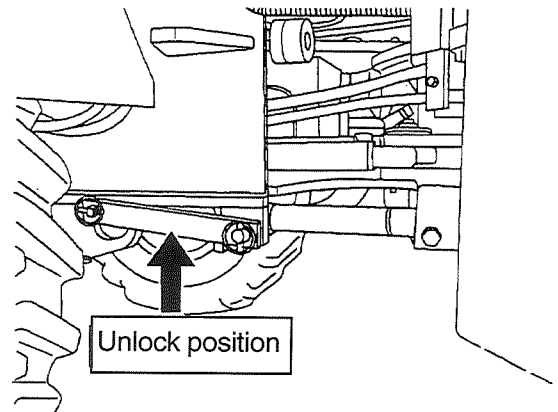

Starting Engine

WARNING

- Sound horn to alert persons nearby.
- Start engine in well ventilated area only. Engine exhaust fumes can cause sickness or death.
- Never start engine while standing on ground. Start engine only from operator's seat, with Speed shift lever in neutral and parking brake applied.

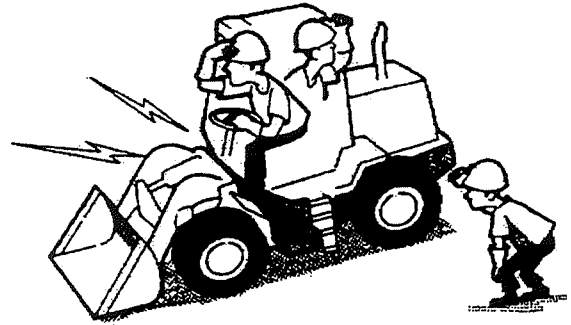

IMPORTANT

- Do not leave starting switch key turned to ON for approx. 20 seconds or more in succession. Otherwise, battery is discharged.
- If engine fails to start after two or three tries, return switch key to OFF. Wait for approx. 2 minutes, then try again.

Starting Under Normal Operating Conditions

1. Turn starting switch key to **ON** position. Check monitoring system for proper function.
2. Depress accelerator pedal one-third way down.
3. Turn starting switch key to **START** position to start engine.
4. After engine has started, release switch key. Key returns to **ON** position automatically.

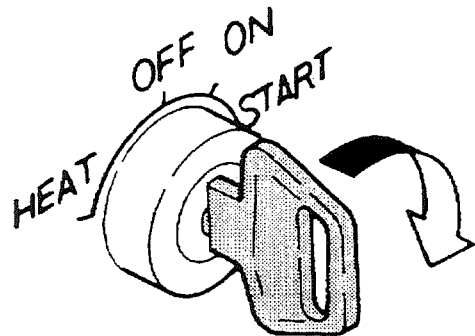
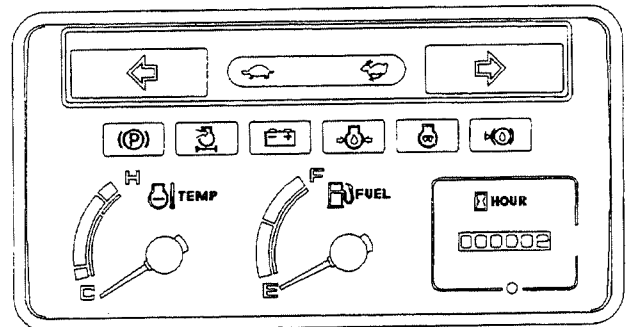

■ Cold Weather Starting

! WARNING
 Don't use starting fluid for starting the engine.
 The starting fluid may cause explosion.



Proceed as follows if the outside air temperature is too low for engine to start:

1. Turn starting switch key to "HEAT" (Pre-heat) position and wait until engine heat pilot lamp goes out.

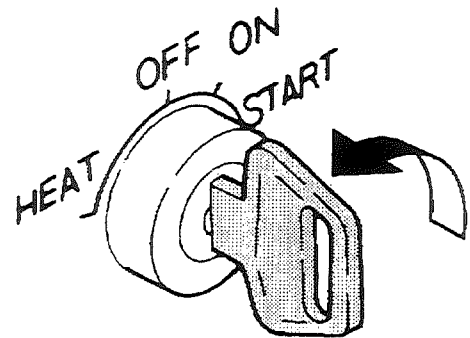

2. After indicator lamp goes out, depress accelerator pedal and turn key to "START" to start engine.
3. When engine has started, release key. Key returns to "ON" position automatically.
4. When engine speed has increased, keep stepping lightly on accelerator pedal.

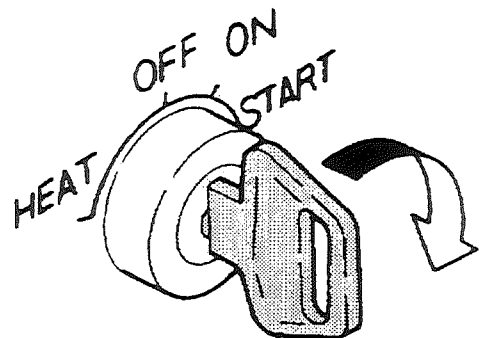

■ After Starting Engine

IMPORTANT

Avoid abrupt acceleration until warm-up is over.

Do not operate machine until you carry out operations and checks listed below.

1. After engine start, check that monitor lamps go off. If some monitor lamp does not go off, stop engine to check cause.
2. After running engine for approx. 5 minutes at low idle for warm-up, depress accelerator up to intermediate position, and operate working device control lever to warm up hydraulic system. Warm-up will circulate lubricant completely through respective sections and warm up engine gradually, raising coolant and oil temperatures for satisfactory operation.
3. Check engine for unusual vibration, noise, smells, exhaust gases, etc.
4. Check hydraulic components, engine, etc. for oil leakage.
5. Operate machine at light load until needle of engine coolant temperature gauge reaches white zone.

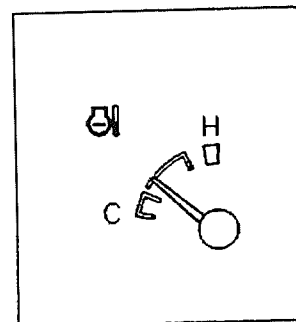
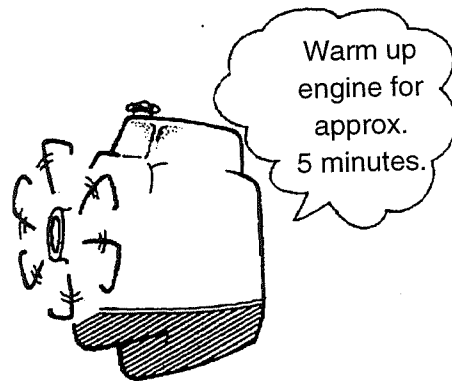
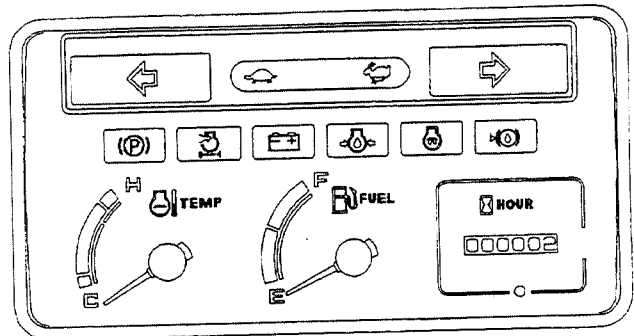

■ Stopping Engine

IMPORTANT

- When you stop engine before it has cooled down, the life of engine may be shortened. Don't stop engine rapidly.
- Cool the engine gradually and then stop it.
- When the engine oil pressure indicator lamp comes on during operation, engine may be seized. Stop engine immediately.
- Turbocharger makes use of exhaust gas energy, so it becomes hot and turns at high speed. The rotary sections of turbocharger are lubricated and cooled by engine oil. Observe the specified idling time before stopping engine, otherwise seizure may occur in bearing.

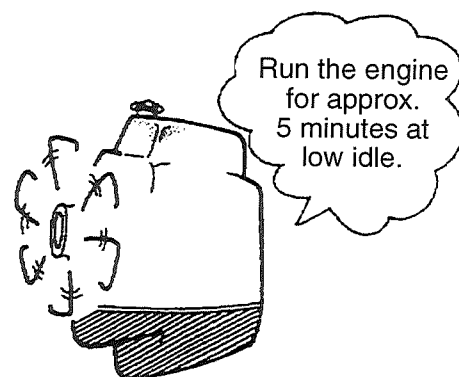
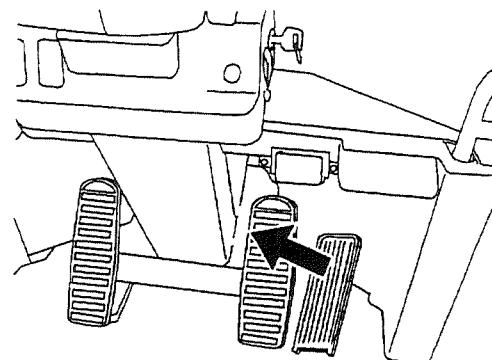

1. Park machine on a level ground and release accelerator pedal.
2. Run engine for approx. 5 minutes at low idle to gradually cool down each section of engine.
3. Turn starter switch key to "OFF" position to stop engine.
4. Remove key.

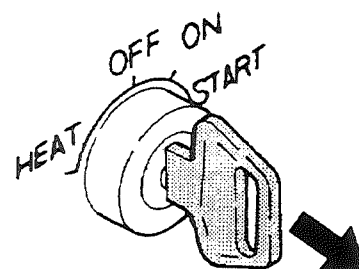

Operating Machine

Operating procedures from starting of machine to parking are described here.

■ Starting Machine

WARNING

- Before starting machine, make sure that there are no persons or obstacles around machine and signal by sounding horn.
- Don't allow persons to stand around machine.
- Space at back of machine is blind spot. Pay special attention when you reverse machine.

1. Unlock working device control lever and set bucket in traveling posture. Tilt back bucket and then put it in air approx. 40cm (16in) above the ground (operating posture).
2. Depress brake pedal and release parking brake.
3. Unlock shift lever and set it in your desirable position.
4. Make sure that there are no persons and obstacles around machine, especially in blind spot. Signal by sounding horn.
5. Release brake pedal and slowly depress accelerator pedal to start machine.

NOTE

When parking brake is applied, machine is kept in neutral condition regardless of shift lever position.

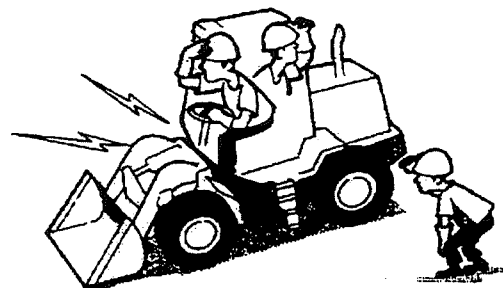
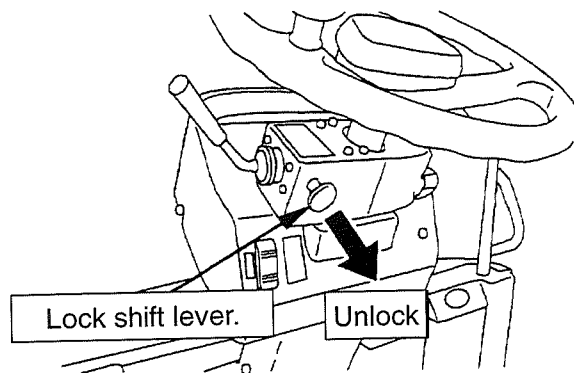
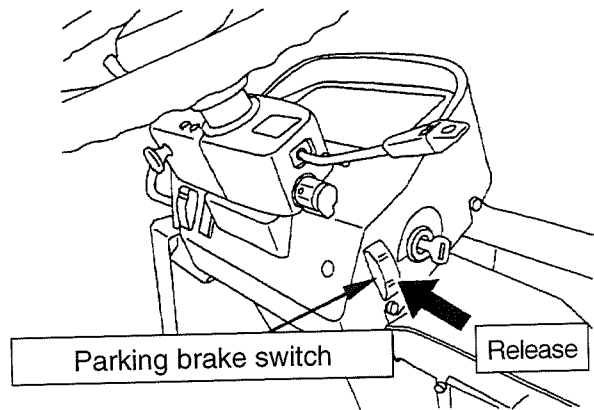
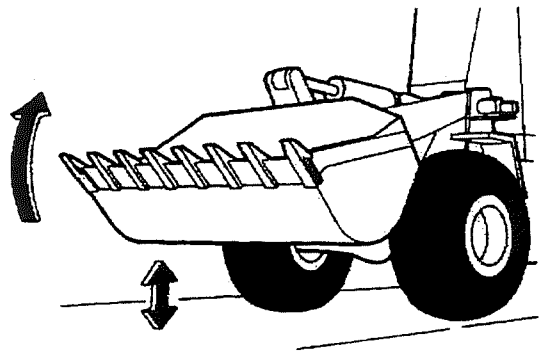

■ Test Operating before Operation

Operate machine for trial in safe place and check for traveling of machine and for operation of various sections.

After warming up, operate working device control lever to move boom up and down, tilt bucket and carry out dumping several times.

During this procedure, make sure that machine operates normally and each section is normal.

Travel machine on a dry ground and apply service brake. Make sure that service brake is fully applied and that braking force is uniform on both sides.

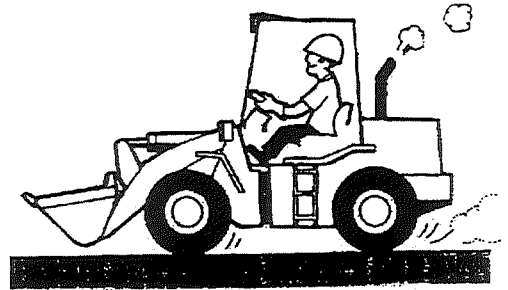

■ Speed Change

WARNING

- Use “work mode” for excavation and loading.
- Use “travel mode” for high-speed traveling and light work.
- To travel on common roads, set a safe speed according to particular road conditions.
- Thoroughly understand the relationship between traveling speed and stopping distance, and determine traveling speed according to working conditions and condition of traveling road.
- Enter “traveling mode” before traveling on a slope. Avoid entering “traveling mode” in middle of a slope.

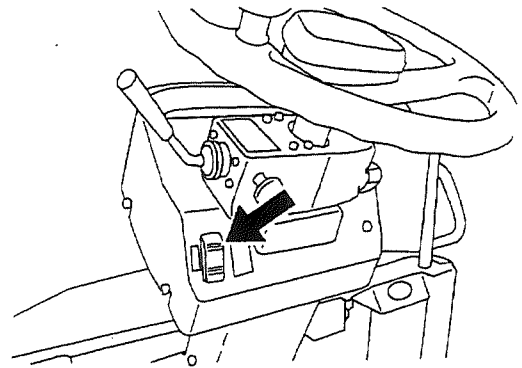

Speed is automatically changed. By operating travel mode selector switch, “low speed” and “high speed” can be selected for forward and backward movement.

■ Changing Direction

WARNING

- When attempting to change forward and reverse directions, make sure of safety in direction of travel. Check that rear is clear before reversing machine.
- Do not suddenly change forward or reverse at high speed.

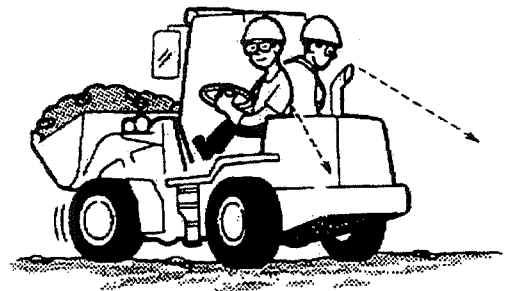

You can change forward or reverse just by changing position of shift lever without stopping machine. Sudden gear changing not only reduces life of machine because of excessive loading of power transmission system, but also places unnecessary overburden on body of operator. Therefore, reduce machine speed before changing.

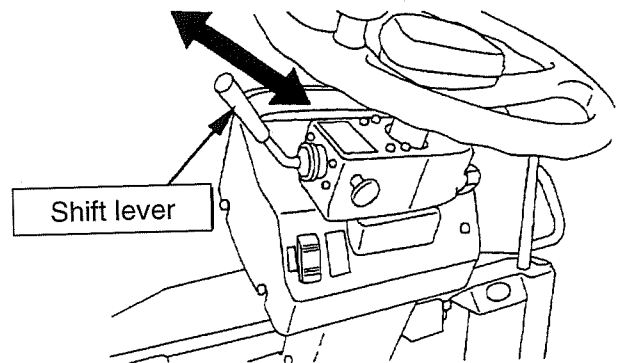

■ Steering Machine

WARNING

- Do not steer machine suddenly at high speed and do not steer machine on steep slope or incline.
- If the engine stops during traveling, the machine cannot be steered. Don't stop the engine during traveling. Especially on a slope, never stop the engine during traveling because it is dangerous. If the engine has stopped during traveling, immediately stop the machine in a safe place.

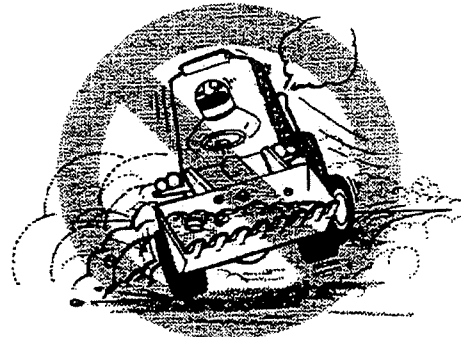

As steering wheel is turned, front and rear frames bend with their respective center pins acting as center of bending.

To steer machine, slowly turn steering wheel so that movement of wheel follows that of machine. Once front and rear frames have bent to touch stoppers, do not turn steering wheel any further in that direction.

■ **Precautions for Traveling Uphill and Downhill**

● **Lower Center of Gravity when Turning**

Lower working device to lower center of gravity when turning machine on slope.

Avoid traverse whenever possible. Danger of tipping and/or turn over is always present.

While operating or turning in narrow places, always pay careful attention to surrounding safety. Also, speed down and operate carefully.



● **Traveling on Slopes**

Stop machine in front of uphill road, and select low gear speed suitable for slope. Do not change gear speed halfway.

Use engine brakes on downhill road and drive machine slowly.

When speed exceeds proper range of selected gear speed, depress brake pedal to lower speed so that engine will not overrun.

When bucket is loaded, go up in forward travel and go down in reverse travel.



● **If Engine Stops**

Stop of engine while traveling makes machine unsteerable.

Depress brake pedal fully when engine has stopped on a slope. Next, lower the working device to ground and apply parking brake.

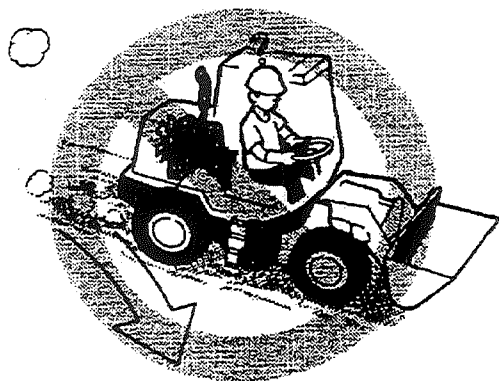

■ Stopping Machine

 **WARNING**

Avoid suddenly stopping, and stop with sufficient distance margin.

IMPORTANT

Unless in emergency, do not apply parking brake. Apply parking brake after machine has stopped.

Lightly step on brake pedal, and HST pump will be forced to enter the neutral state, and deceleration (braking) function of HST will be activated.

When brake pedal is stepped on further, deceleration (braking) function of HST and function of the service brake will stop machine more powerfully.

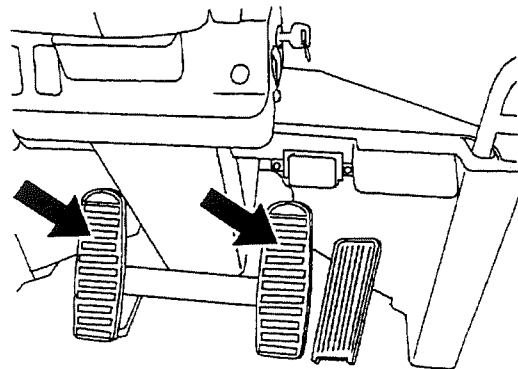
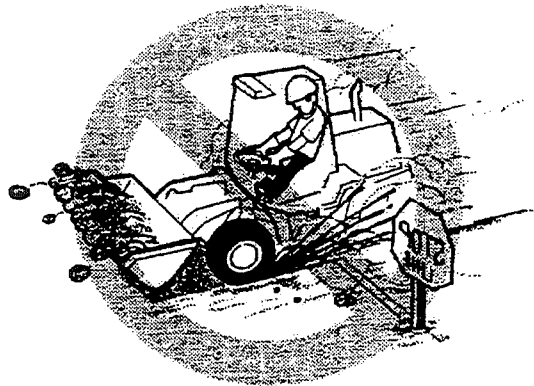

● When Brakes Do not Work

IMPORTANT

When you have used parking brake as emergency brake, ask your authorized dealer for inspection of brake.

Use parking brake to stop machine only when machine will not stop even if you depress brake pedal.

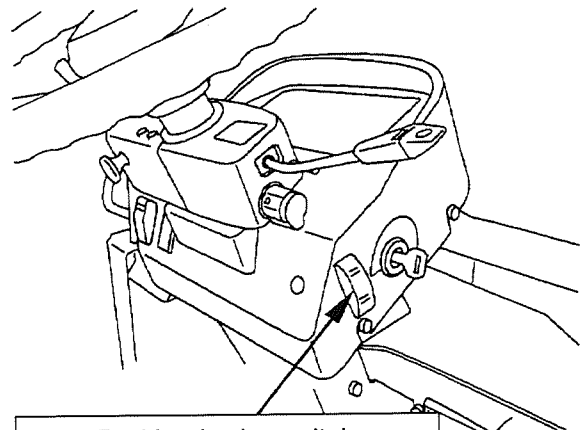

Parking brake switch

■ Parking Machine

! WARNING

- Select a firm, solid ground for parking machine. Machine parked on slope may go out of control by its own weight. If machine has to be parked on slope, park it at right angle with slope, block tires to prevent movement and penetrate bucket into ground.
- If you must park machine on street, use appropriate flags, barricades and warning signals.
- When you leave machine, put bucket on the ground, set safety lock devices to "lock", stop engine and then lock all keys.

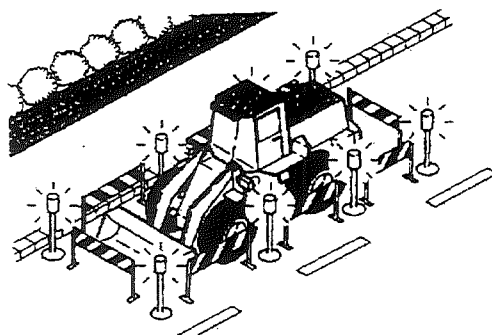
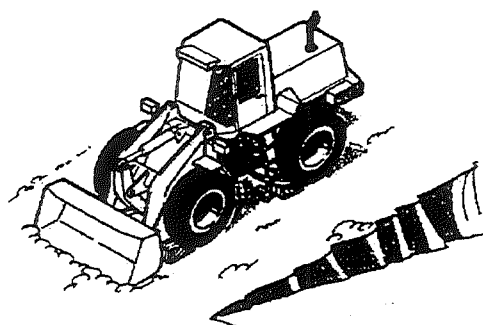

1. Release accelerator pedal to decrease machine speed and then depress brake pedal to stop machine.

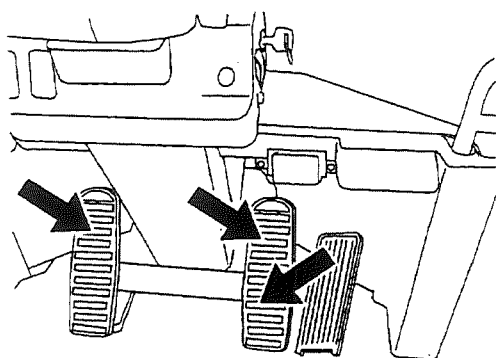

2. Return shift lever to "N" (Neutral) to lock it.

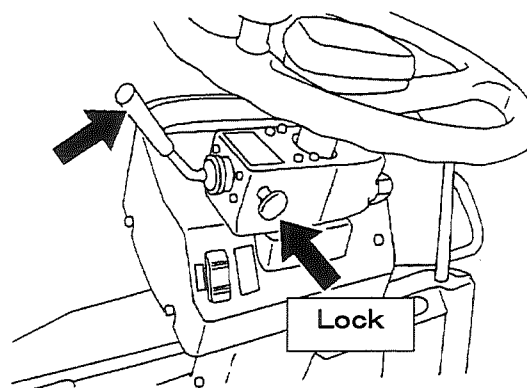

Operating Machine

3. Set the parking brake switch to “ON” to apply the parking brake.

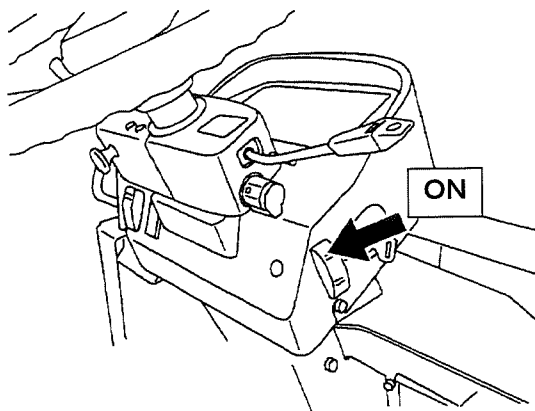

4. Operate the working device control lever to put the bucket onto the ground horizontally.

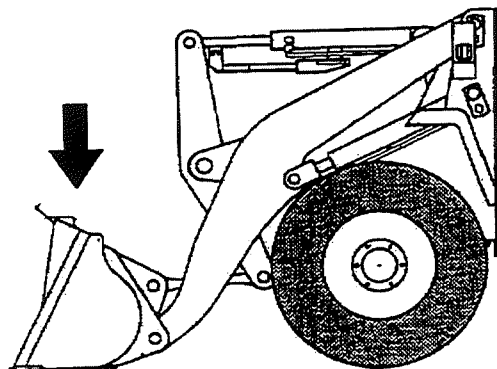

5. Lock the working device control lever.

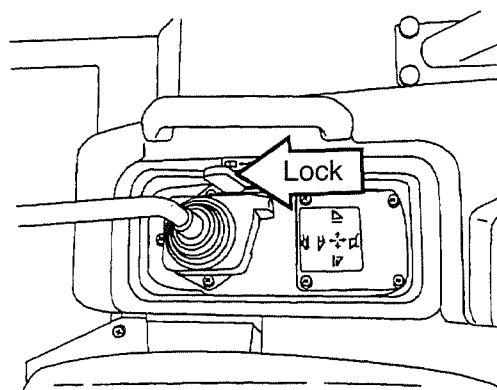

6. Stop the engine. Refer to “Stopping Engine”.

7. Remove the starter switch key and store it in the specified place.

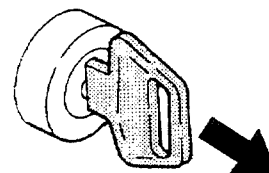

Operating Procedures

■ General

Carry loaded bucket as low as possible for better stability and visibility.

Carry loaded bucket fully tilted back and towed approx. 40cm (16in) from ground level.

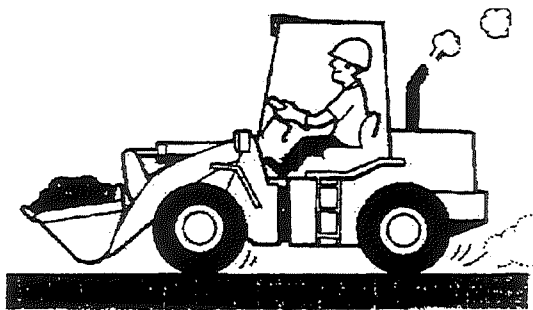

Level work site utilizing idle time.

Smooth surface increases work efficiency and makes machine operation easy. If work site is very sandy or dusty, sprinkle water over ground before working on site.

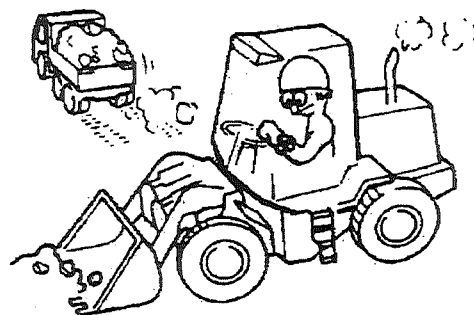

When dumping bucket, keep dust away from engine and maintain visibility. If possible, dump with wind to your back.

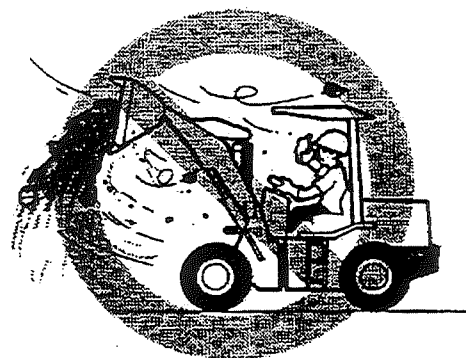

Avoid excessive down pressure on bucket, such as front wheels are raised.

It cause loss of traction and applies excessive force to drive train.

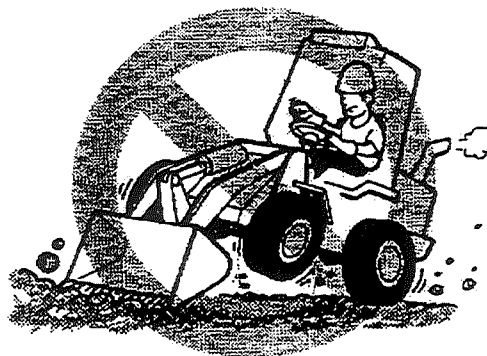

■ Dozing

When dozing, keep bucket bottom to parallel to ground.

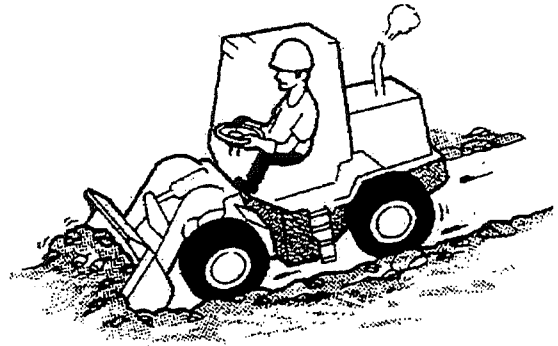

■ Leveling

Be sure to level ground while reversing machine.

1. Scoop soil into bucket and, while reversing machine, dump material little by little to level ground.
2. Dump bucket to rest cutting edge of bucket on ground and reverse machine to drag bucket for leveling ground.
3. Scoop some more soil into bucket, put the working device control lever in FLOAT position, level bucket and ground level, and smooth ground by moving reverse.

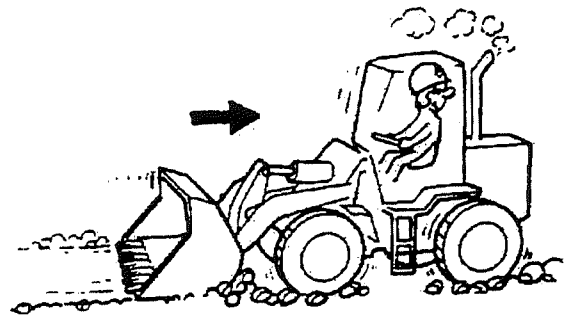

■ Load and Carry Operations



WARNING

When carrying load, lower bucket to lower center of gravity.

Load-and-carry operation is working method in which excavating/loading operations and carrying operations are to be carried out together using wheel loader. Conditions of road surface significantly affect lives of tires. Always make road surface flat and smooth.

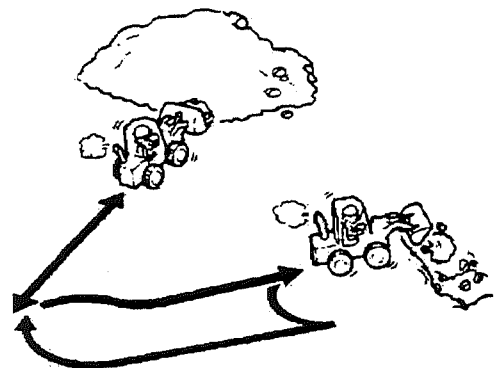

Excavating

WARNING
 When carrying load, lower bucket to lower center of gravity.

IMPORTANT

- Slippage of tires shortens life of tires. Exercise care so as not to slip tires.
- When excavating with bucket, make sure that bucket receives even load at both end. Avoid uneven loading.



1. Lower bucket to ground and hold it for slight digging angle.

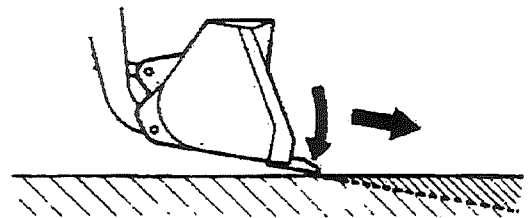

2. Move machine forward while applying down force. Return control lever to HOLD when sufficient penetration is obtained. Tilt working device control lever forward slightly and move machine forward to dig soil little by little.

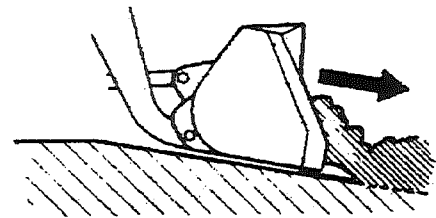

3. Excavate in parallel to ground by adjusting bucket angle with working device control lever. When bucket is loaded, raise it.

4. Adjust height of bucket to approx. 40cm (16in) from ground level, and carry scooped deposit.

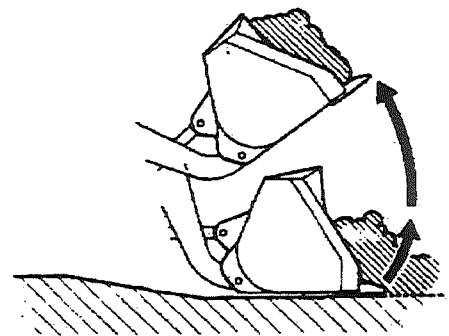

■ Loading

WARNING

- Longitudinal stability of machine deteriorates while loading with bucket and lift arm section remaining moved upward to its maximum height. During such loading, slowly move machine and carefully tilt bucket and arm section forward.
- Machine must not be moved forward at high speed. Otherwise, not only machine itself may become damaged, but also may operator get injured.
- Never operate digging or loading with machine articulated.

IMPORTANT

- Slippage of tires shortens life of tires. Exercise care so as not to slip tires.
- Do not swing bucket excessively.

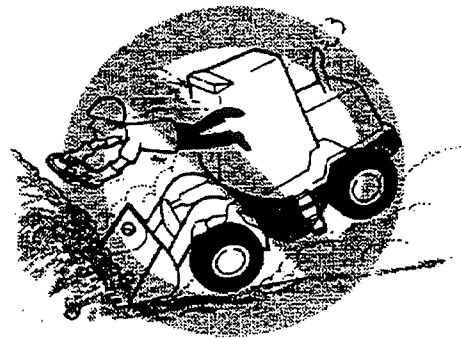
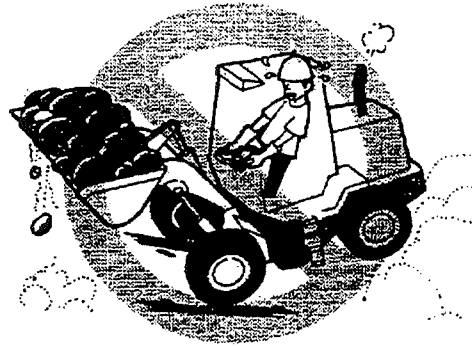

Minimize turning and travel distances in accordance with configuration of ground in order to operate efficiently.

● **V-pattern (V-shape loading)**

Park truck at approx. 60° with regard to direction of loading.

After filling bucket, move machine backward, move it so that it is at right angle to truck and then move it forward to unload material into truck.

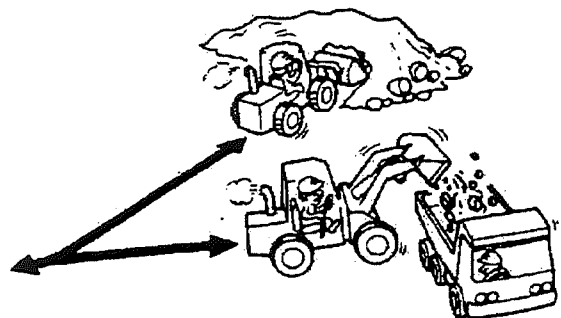

● **I-pattern (Cross-drive loading)**

Place machine at right angle to stockpile and dig.

Load bucket and move machine backward. Drive truck between stockpile and machine and then unload material into truck.

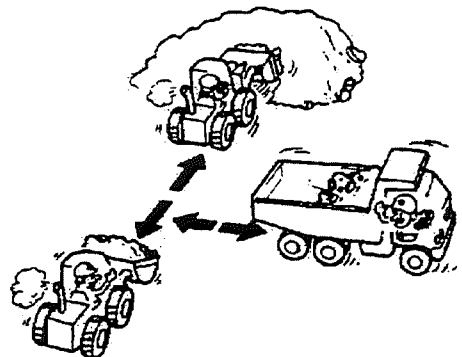

● **T-Pattern**

Park truck in parallel with stockpile.
Work between stockpile and truck.

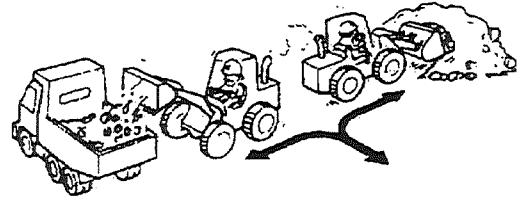

■ **Loading Truck with Deposites**

1. Level bucket and lower to ground.
Move machine forward, crowding bucket straight into pile.
2. Move forward moving cutting edge of bucket in vertical direction with the working device control lever, and load bucket adjusting lift arm and bucket.
3. When bucket is loaded, place control lever in TILT BACK position and raise it high enough to clear material being loaded.
After filling bucket, move machine backward.
4. Carry loaded bucket approx. 40cm (16in) from ground level.
5. Park truck at position at which turning and traveling machine is minimized.
Move machine in direction of square to truck.
6. Travel forward to truck while raising bucket to clear truck sideboard.

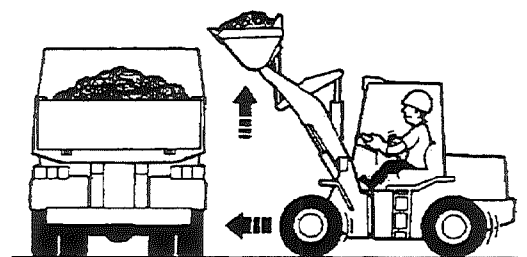
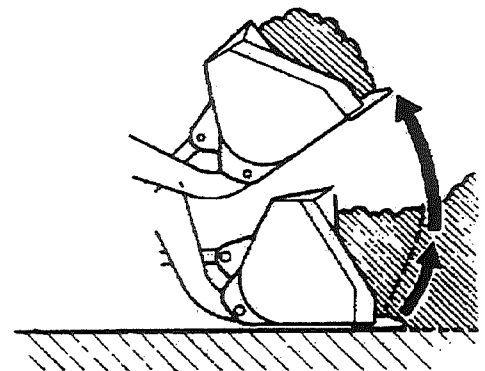
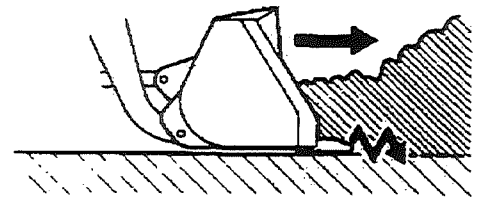

Operation Procedures

7. Move to position in which load can be dumped into middle of load-carrying platform of truck.
If length of truck body is more than twice bucket size, load truck from front towards rear.
8. Place control lever in DUMP position.
When dumping clay soil, which cannot be easily dumped, have bucket hit stopper.
9. Place control lever in TILT BACK position.
10. Reverse machine and lower bucket near ground.

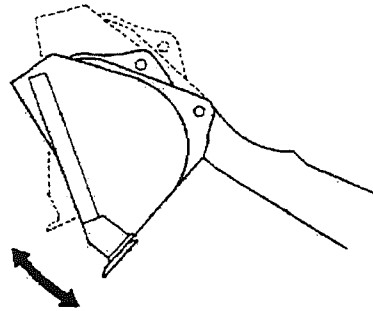

■ Allowable Water Depth

When working in water, investigate water depth and bottom conditions.

Do not exceed allowable water depth (bottom of axle housing).

After finishing operation, apply grease to all lubricating points that have been exposed to water.

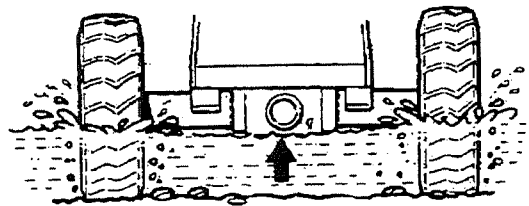

Servicing Batteries

Precautions for Servicing Batteries

WARNING

- Battery generates flammable gas and may explode. Sparks or open flames must be kept away from battery.
- Do not smoke when servicing battery.
- Electrolyte is dangerous material. Be extra careful not to allow liquid to come into contact with your eyes or skin. If electrolyte contacts with your clothes or skin, wash away with water at once. If electrolyte contacts with your eye, wash it away with much water and consult with a doctor.
- Before checking and servicing battery, stop engine and turn starter switch key to OFF.
- Wipe off dust collected atop battery with wet cloth before starting engine.
- Always wear protective glasses when working with batteries.
- To remove battery, be sure to disconnect battery cables from grounding terminal ((-) terminal) and other terminal ((+)terminal), in that order. To remount battery, be sure to reconnect battery cables to(+)terminal and(-) terminal, in that order. Sparks will occur if, with terminal remaining connected, tool or other metallic materials are brought into contact with (+) terminal or vehicle body.
- Loose terminals cause sparks due to poor contact, leading to explosion. Firmly tighten terminals.

NOTE

Battery is located at right hand side in engine room.

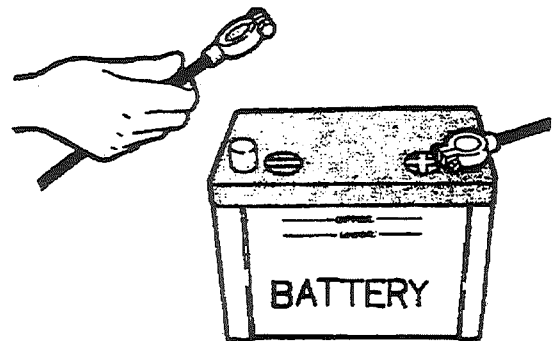
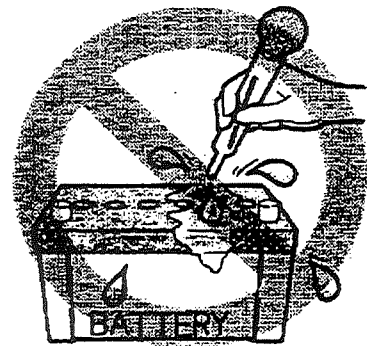
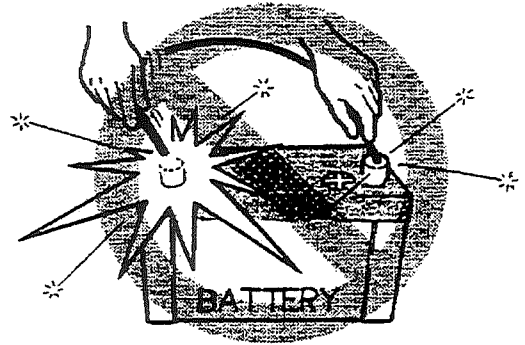
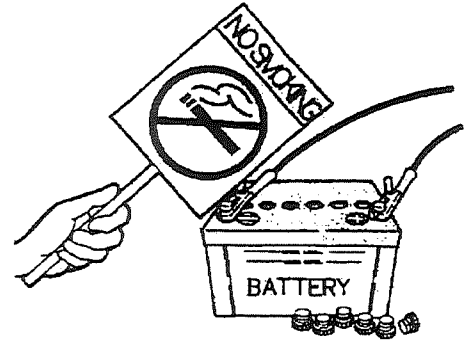

■ In Cold Weather

Decrease in outside air temperature reduces capacity of battery, and thus causes electrolyte to freeze if battery has not been fully charged. Always keep rate of charging as close as possible to 100%.

If necessary, refill battery with distilled water before charging.

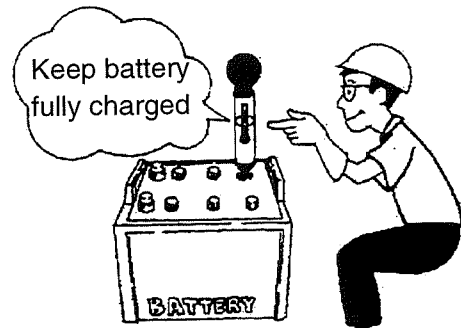

■ In Hot Weather

Electrolyte will evaporate and electrodes can expose to air. This will damage electrodes.

■ Precautions for Battery Charging

While charging, all caps must be removed to let out any internal gases. Battery gas can explode. Keep sparks and flames away from batteries.

Discontinue charging if battery has become overheated. After completion of charging, immediately stop charging to prevent overcharging. Positive cable and a negative cable must always be connected to (+) terminal and (-) terminal, respectively.

- If battery is to be charged on machine, change the battery terminal arrangement before charging. Battery charger can damage alternator with abnormal voltage.

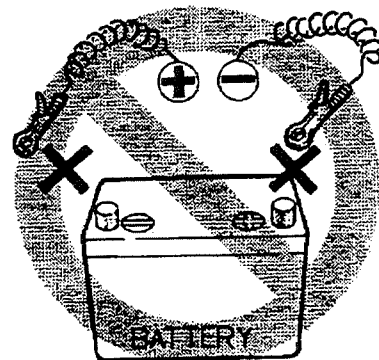
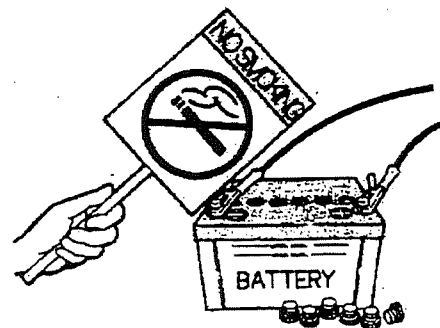

Check Electrolyte Specific Gravity

Rate at which battery is charged can be expressed by measuring specific gravity. Using table given at right, convert measured data into rates of charging. Always maintain rate of charging of 75% or more.

Electrolyte temperature (°C) \ Rate of charging(%)	20	0	-10
100	1.28	1.29	1.30
90	1.26	1.27	1.28
80	1.24	1.25	1.26
75	1.23	1.24	1.25

Using Booster Batteries



WARNING

- When starting from another machine, never allow machines or boost cable clamp to touch each other. This prevent sparks near battery, which could ignite hydrogen gas given off battery, causing battery to explode.
- When using auxiliary batteries, be sure to wear glasses to protect your eyes from sparks.
- If the battery cable is removed from the machine which has already started, be careful to prevent the cable end from touching the machine.
- Always turn starting switch and accessory switches to OFF position before connecting booster batteries.

IMPORTANT

- Use a battery of same capacity as the trouble machine for a normal machine.
- Use a booster cable and clip applicable to the size of battery.
- Check cables and clip for disconnection and corrosion. Make sure that cable and clip are securely connected.
- Make connection of battery as follows: POSITIVE(+)to POSITIVE(+) and NEGATIVE (-)to NEGATIVE(-). Don't connect POSITIVE (+) to NEGATIVE or NEGATIVE (-) to POSITIVE (+).
- Connect boost cable correctly.
- To prevent sparking around battery, connect the body and engine block to a point as far from battery as possible.

Servicing Batteries

■ Connect and Disconnect Boost Cables

Usage of boost cables to start engine of faulty machine and normal machine is described below.

■ Connect Booster Cables

Connect booster cables in following order;

1. Connect one cable (A) clip to positive (+) terminal ① of battery in faulty battery.
2. Connect opposite end clip of cable (A) to positive (+) terminal ② of normal battery.
3. Connect other cable (B) clip to negative (-) terminal ③ of normal battery.
4. Connect opposite end clip of cable (B) to body ④ or engine block of faulty machine.
5. After connecting, check if clips are securely connected to battery terminals before starting engine.
6. Start engine.

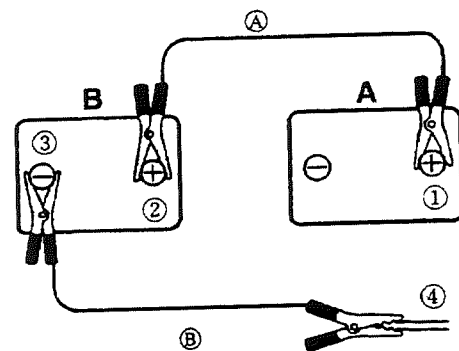

A: Faulty battery
B: Normal battery

■ Disconnect Booster Cables

1. After engine starts, remove cable (B) clip from body ④ or engine block first.
2. Remove opposite end clip of cable (B) from negative (-) terminal ③ of normal battery.
3. Remove cable (A) clip from positive (+) terminal ② of normal battery.
4. Remove opposite end clip of cable (A) from positive (+) terminal ① of faulty battery.

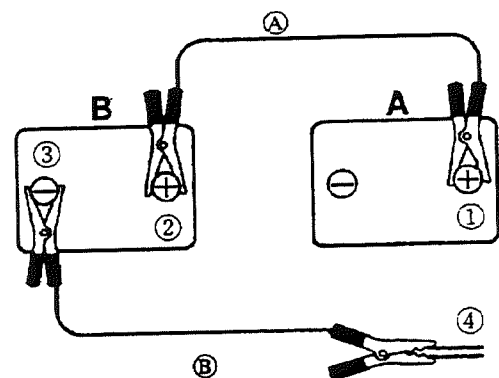

A: Faulty battery
B: Normal battery

Operation in Cold Weather

Decreases in atmospheric temperature cause engine-starting failures, freezing, etc. Observe following notes:

■ Hydraulic Oil

Oil becomes thick and heavy when atmospheric temperature drops. Use proper viscosity oil.

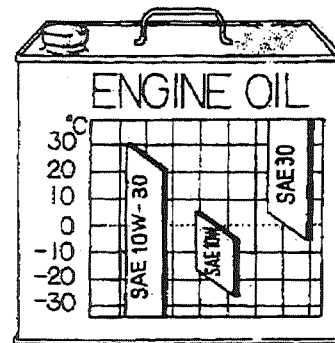

■ Fuel Oil

Open drain plug to drain any condensate from fuel system at end of each day's operation. This prevents fuel line from freezing. Also, fill up fuel tank, to prevent condensation within tank.

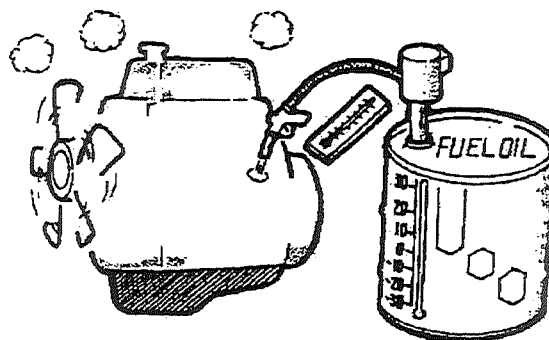

■ Battery

Decrease in atmospheric temperature reduces capabilities of battery, and thus causes electrolyte to freeze if battery has not been fully charged. Keep battery fully charged at all times, and provide heat insulation so that engine can be started smoothly on next morning.

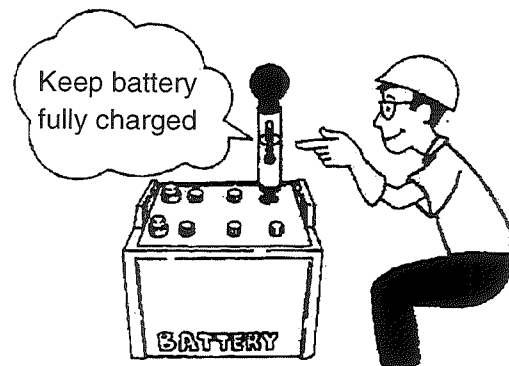

■ Coolant

Maintain coolant freeze protection level.

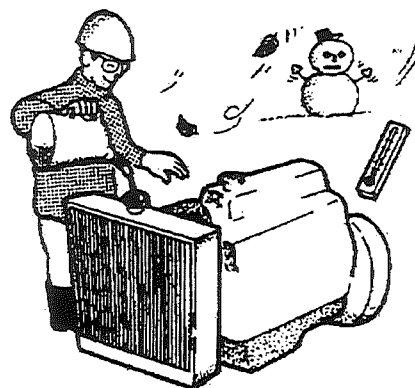

Operation in Cold Weather

■ Precautions for Operations

Remove ice, snow or mud from machine body. Any such foreign matter must be removed from surfaces of hydraulic cylinder rods, in particular, otherwise seal damage may result. After engine has started, provide sufficient warming-up to make hydraulic oil warm.

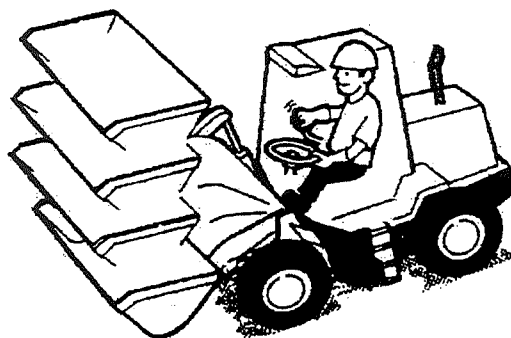

Operate machine with reduced load and speed until gauge be in white zone.

See "Fuel, Water and Lubricants Selection and Capacities" specifications of fuel, lubricants and anti-freeze.

NOTE

When cold season is over, change oil and fuel in each equipment to those with specified viscosity that match atmospheric temperature.

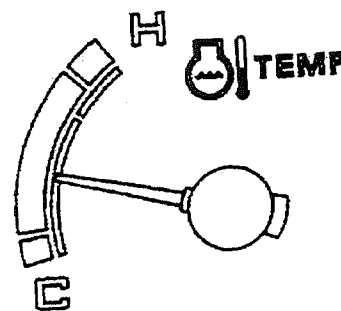

Tire Maintenance

■ Precautions for Tire Maintenance

WARNING

- Tire must be inflated at specified pneumatic pressure. Insufficient pneumatic pressure causes abnormal heating, leading to busting.
- Do not stand in front of tire when adjusting pneumatic pressure. When tire wheel is deformed, it may be blown off, causing serious injury or death.
- Do not fill tire with inflammable gas or air that contains volatile substances.
- Do not weld rim without removing tire, or do not make fire or conduct welding near wheels or tires. Heated tire will generate inflammable gas, and ignition of such gas will cause explosion, leading to serious injury or death. Unlike puncture and other types of rupture, explosion of tire generates strong breaking force, which is very dangerous.
- When tires are used under severe working conditions, internal pressure of tires will become abnormally high because of generated heat. In that case, slow down traveling speed or lessen load. Do not release pressure from tires at that time.
- Use specified tires. Pneumatic pressure for tires shown in manual is for general cases. Pneumatic pressure of tires depends on operating conditions and type of tires.
Contact your TCM dealer for details.
- Replacement or maintenance of wheels and tires without correct understanding of proper method may cause breakage or explosion of wheels and tires, causing accident that leads to injury or death. Contact your TCM dealer, or qualified repair service for maintenance.

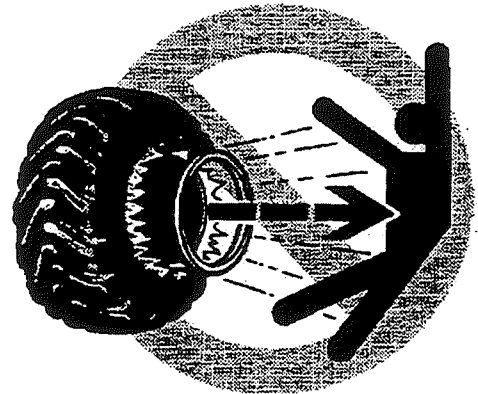
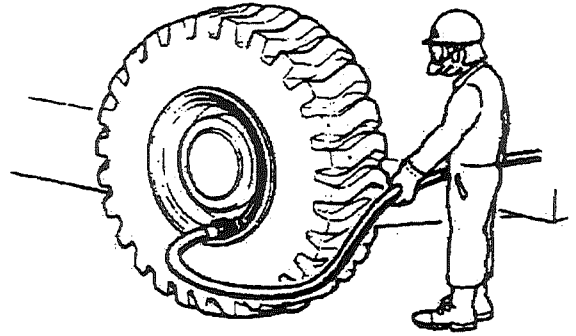

Tire Maintenance

■ Tire Pressure

Proper tire pressure is essential to get best performance from tires. Optimum traction, flotation and load endurance can only be obtained if proper inflation pressure is maintained.

Excessive air pressures increase tension of rubber and chord section of each tire because of reduced ground contact areas of treads. As a result, tire damage due to cracking or shocks becomes prone to occur.

Insufficient air pressure cause tires to repeat excessively bucking, which in turn may create similar situation to overloading and make tires prone to burst because of resulting heat.

In this way, both excessive and insufficient air pressure significantly affect lives of tires and operation of machine. Air pressure must, therefore, be adjusted as specified.

Adjust air pressure of tires to within ranges specified in table right. Also, perform adjustments according to particular working conditions.

To work at sites of soft ground, adjust air pressure to level slightly lower in specifications, or to work on ordinary roads, adjust air pressure to level slightly higher in specifications.

Measure air pressure under cold-air condition (while tires are cool).

While operation, since air pressures increase because of heat of tires, they usually become higher than under cold-air condition. If air pressures are higher than usual by 98 Kpa (14.2 PSI) or more, reduce either operating speed or load. Deflating tires must be avoided in that case.

While air pressure checking, closely observe for tire flaws and burrs and check for nails or other metallic pieces that may cause puncture, and for unusual wear.



Insufficient
air pressure

Appropriate
air pressure

Excessive
air pressure

Air pressure table KPa

Tire Size	Air Pressure
L3-2 10-16.5-4PR Tubeless Tire	196 to 215
L4-2 12.5/70-16-6PR Tubeless Tire	196 to 215
L5-2/L6-2 15.5/60-18-8PR Tubeless Tire	215 to 235

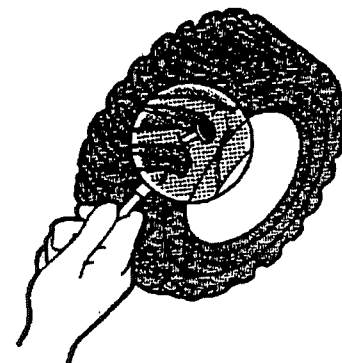

NOTE

Maintenance of road surface is one of most important factors in determining life of tire. Bumps, check holes, rocks and so on cut and wear tires, even bursting can result.

Of particular importance is maintenance of loading and dumping areas because chances of damage at these places are great. Road and ground conditions there have large effect on productivity of machines.

■ **Remove Tire**

1. Lower the working device on ground and apply parking brake.
2. Loosen all hub bolts by 1 turn.
3. Jack up machine and hold.
4. Remove hub bolts to replace tires.

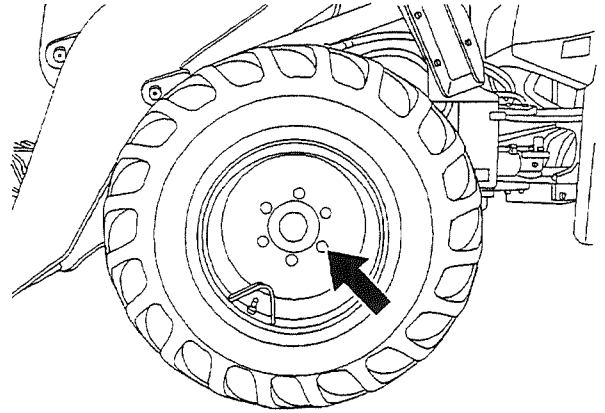

■ **Install Tire**

1. Tighten hub bolts lightly, while tires are raised up. Order of tightening is shown in right figure.
2. After tightening hub bolts temporarily, lower machine.
3. Retighten them to specific torque.

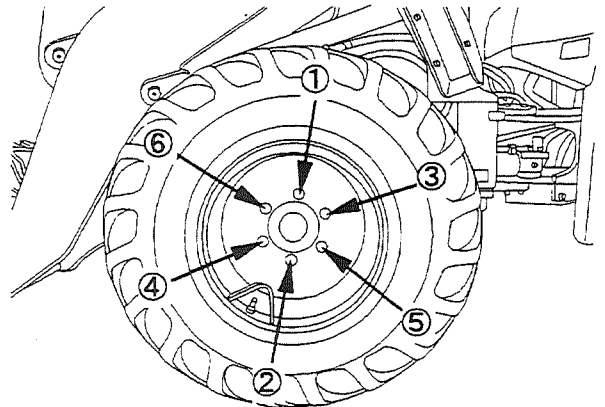

Model	Tighten torque (Nm)
L3-2	278 to 306
L4-2	375 to 412
L5-2 L6-2	375 to 412

■ **Tread Pattern Direction**

Pay attention to installing direction.

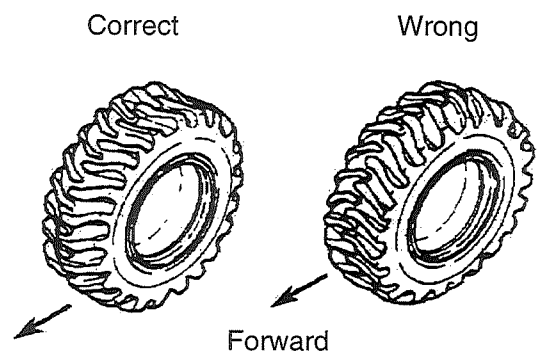

Seat Belt



WARNING

When you drive a machine with seat belt, be sure to use it.

■ Inspection and Adjustment of Seat Belt (Option)

● Inspection of Seat Belt

1. Before using seat belt, check belt metal parts for looseness.
2. If seat belt is damaged or its surface gets fluffy or if metal parts are broken or deformed, replace seat belt with a new one.

● How to Use Seat Belt

1. Adjust seat to take a proper operating posture.
2. Insert tab into buckle and make sure that it is securely locked.
If belt is too short for you, make buckle or tab in right angle with belt at fixed side and pull belt. It is made longer.
3. Set the belt along your body without twisting.
If belt is too loose, pull free end of belt at buckle or tub side. It is made shorter.
4. To unfasten seat belt, press unlock button of buckle.

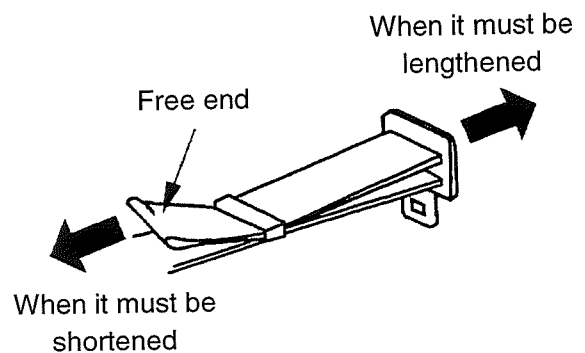
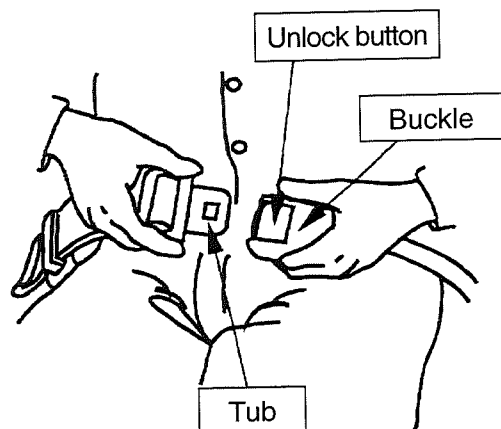

Transporting

■ Transporting

Transport machine safely by using a trailer, truck or other proper vehicles and observe laws for road traffic, transport vehicles, vehicle limit, etc. Decide a transport route by investigating the road width, height and permitted weight.

Put working devices on bed, set chocks at front and rear of tires to prevent machine from moving and fix machine with wire rope or chain.

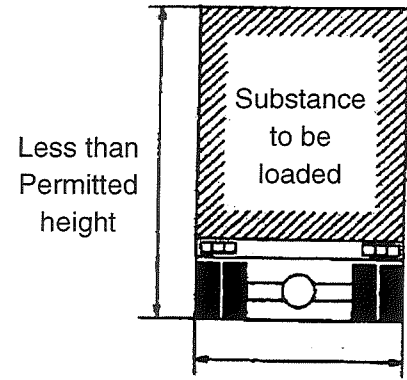

Less than permitted width

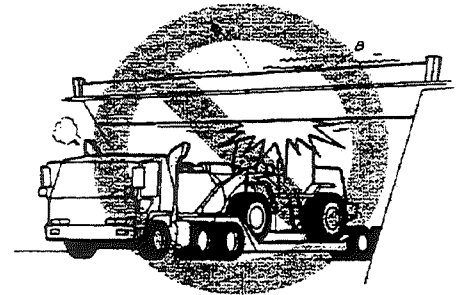

The dimensions of the machines at shipment are shown in the table below.

Item	Model	Model			
		L3-2	L4-2	L5-2	L6-2
Machine Mass (with Canopy)	kg	1895	2625	3245	3545
Overall Length (with BOC)	mm	3440	4140	4425	4695
Overall Width (with Bucket)	mm	1350	1570	1690	←
Overall Height (with Canopy)	mm	2350	2415	2495	←
Overall Height (with Cab)	mm	2395	2460	2540	←

■ Precautions for Loading and Unloading

! WARNING

- Load and unload machine under directions of signal person.
- Load and unload machine on level, firm surface. Transport vehicle must have its parking brakes applied and its tires chocked.
- Ramp capacity must be greater than weight of machine. Ramp must have low angle and correct height.
- Use ramp equipped with hooks so that it will not come off trailer bed.
- Go up ramps directly and never change course halfway on ramps. When changing course, descend first of all and correct direction.
- Before loading and unloading machine, remove any ice, snow, or other slippery substances from trailer bed and from ramps.

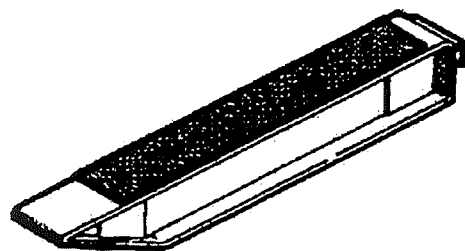
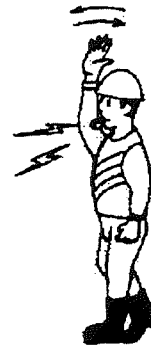

● Using Banked Soil for Loading and Unloading

1. Banked soil must have sufficient width for machine to ensure safety.
2. Banked soil must be fully tamped beforehand to prevent side slopes from crumbling while operating. Also, slope of banked soil itself must be made as gentle as possible.
3. Make banked soil flush with trailer bed.
4. Load into required position of trailer bed.
5. Block tires and tie down machine to trailer with chains or wire cables.

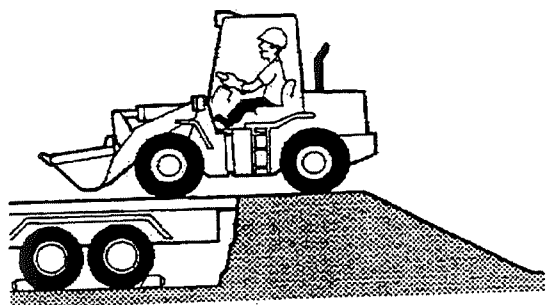

● **Using Ramps for Loading and Unloading**

1. After stopping trailer in loading/unloading position, apply parking brakes of truck and lock tires of truck using chocks.
2. Appropriately apply ramps to trailer bed so that ramps do not come off. Slope ramps to 15 degrees or less.
3. Adjust layout of ramps for accurate alignment between center lines of trailer bed and machine and between those of ramps and machine.
4. Drive at low speed in accordance with signal person, and stop in front of ramps. Recheck loading position there.
5. Orient front end of machine towards ramps, and drive across at low speed without stopping. Do not steer on ramps even if that becomes necessary. When necessary to steer, descend first of all and correct direction.

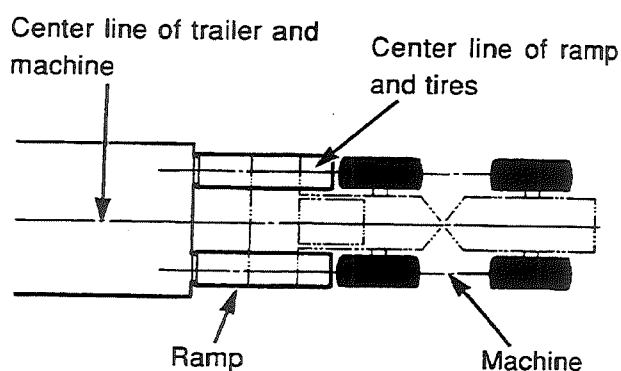
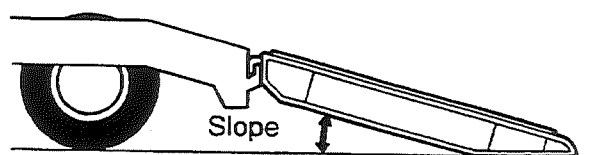

■ **Precautions for Loading**

1. Stop machine at required position of trailer bed, and apply parking brakes of machine.
2. Lock front and rear frames of machine using safety bar.
3. Lower bucket onto floor surface of trailer bed, then set each control lever in neutral position, and apply safety locks.
4. Stop engine, and remove key from starting switch.
5. Lock tires using chocks to prevent machine from moving while transport, and then securely fix machine using wire ropes or chains.

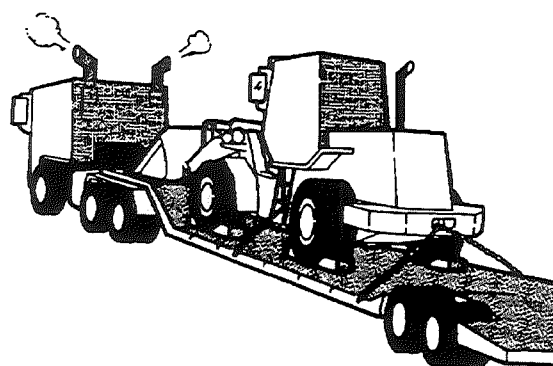
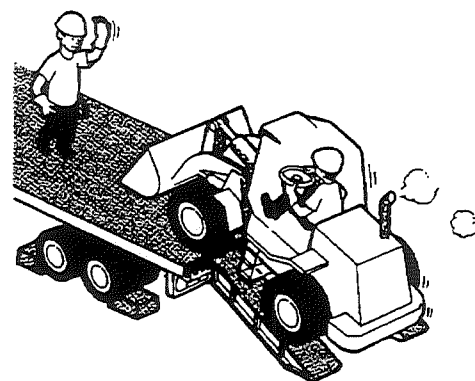

Transporting

- Towing in slope is prohibited.
- Firmly connect the machine to tow and the one to be towed in line.
- When the machine begins to move suddenly, the towing rope or bar is overloaded and may be broken. Move the machine slowly at constant speed.
- The machine to tow must have the same size as the one to be towed. The machine to tow must have a sufficient braking function, weight and towing power to be able to control both machines on slope and towing route.
- When towing a vehicle along downhill, it is necessary to add a larger-sized vehicle at the back of the vehicle to be towed so that it can be fully controlled.

● If Engine Operates

When the transmission system and handle are operable and the engine rotates, let a person get on the vehicle to be towed and perform steering in the towing direction to pull out the vehicle from mud or move it to the side of road.

● If Engine Does Not Operate

● If Traveling is Impossible

This machine uses HST (transmission). When the engine does not operate or traveling is impossible, the HST brake works and the machine cannot move.

When towing the machine, remove the propeller shaft. Release the parking brake manually. Refer to “**How to Release Parking Brake Manually**” .

When the engine does not operate, steering is impossible. Remove the pipes from the steering cylinder.

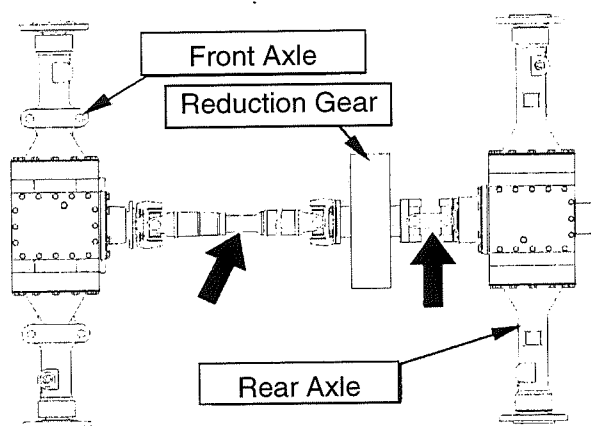

How to Release Parking Brake Manually

WARNING

Each section is hot right after engine has stopped. Wait until each section is cooled down.

Parking brake is released by oil pressure. When engine stops, parking brake is not released even if its switch is set to "OFF".

When engine is not activated and the machine must be towed, release the parking brake forcedly (manually).

1. Remove bolt ① (bolt for releasing, M10xL55).
2. Remove plug ②.
3. Tighten bolt ① into port B from which plug ② was removed.

Parking brake piston is pulled back to release parking brake and so you can move machine.

4. After the work, remove the bolt ① from the port B and insert the plug ② into it.
5. Set the bolt ① to the original position.

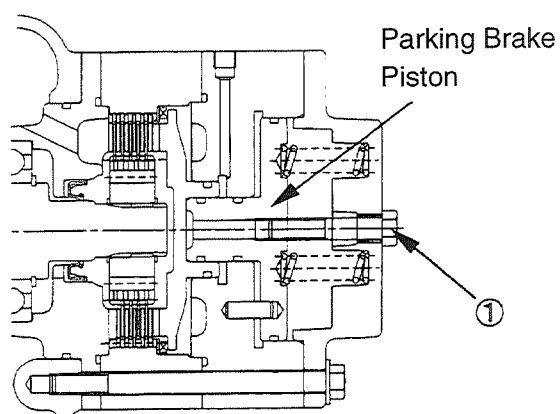
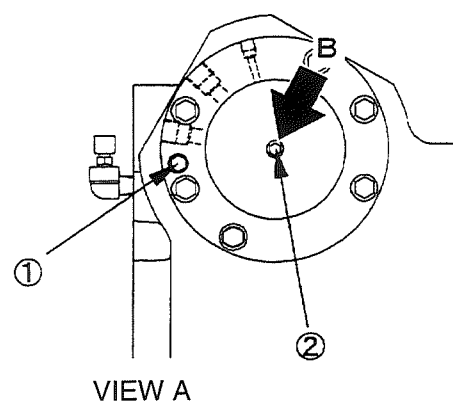
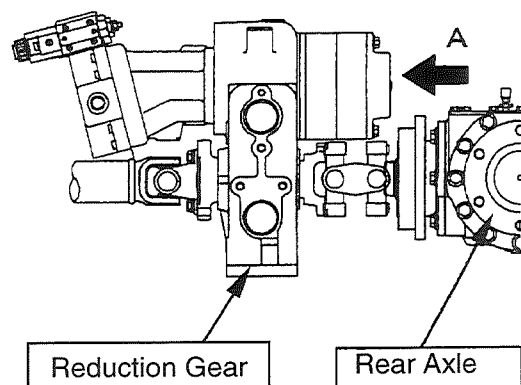

Long-Term Storage

If machine is not to be used for long periods of time, store it as directed below.

■ Prepare Machine for Storage

- Store your machine inside only after cleaning various sections of machine. If it becomes absolutely necessary to store machine outside, lay lumber on level ground and cover with water-proof material.
- Carry out refilling oil, lubricating, and oil replacements.
- Apply grease to exposed sections of piston rods of hydraulic cylinders.
- Disconnect cable from (-) terminal of battery, or remove battery from machine and store battery insides. Fully charge battery.
- If atmospheric temperature is likely to decrease below 0 °C, drain out coolant or add anti-freeze to prevent freezing.
- Apply parking brakes, and lock tires with chocks.
- Adjust tire pressure to specifications.

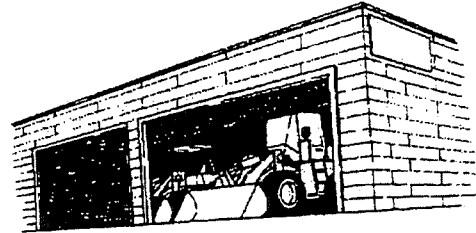
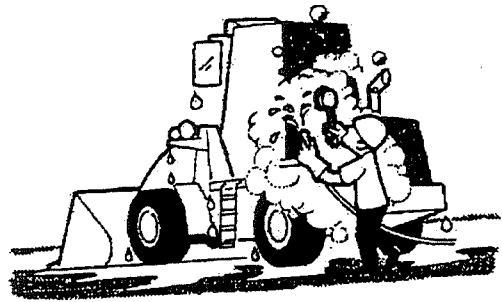

■ While Storage Periods

WARNING

When starting engine inside for prevention of corrosion, open windows and entrance of storage room to provide appropriate ventilation.

- Start engine at least once a month to prevent damage to oil seals of sections which require lubrication.
- Adjust tire pressure to specifications.
- At same time, fully charge battery.

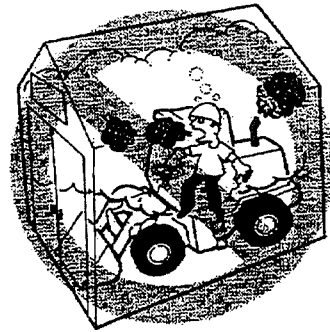

■ Reusing Machine

Before reusing machine that has been stored for long period of time, see section of manual related to "Periodic Maintenance/Daily" and carry out following operations:

- Apply oils and grease to all required sections.
- Remove grease from hydraulic cylinder rods.
- Adjust tire pressure to specifications.
- After engine start, run engine at low idle for 5 minutes or more so that lubricant flows into various sections.

MAINTENANCE



Maintenance

When anomaly is found while inspection or operating, inspect cause immediately, and repair machine. When cause of trouble is unknown and regarding hydraulic equipment, contact your authorized dealer.

■ Complete Preparation

When performing any service of machine, do following steps unless otherwise specified.

- Park machine on level surface.
- Move transmission control lever to NEUTRAL.
- Apply parking brake, and lower bucket to ground.
- Stop engine, and remove starting switch key.
- Move working device control lever several times to relieve hydraulic pressure.
- Set the safety lock to the lock position.
- Chock tires to prevent moving.
- Connect the front and rear frames with the safety bar.
- Attach "DO NOT OPERATE" tag to steering wheel or starting switch.

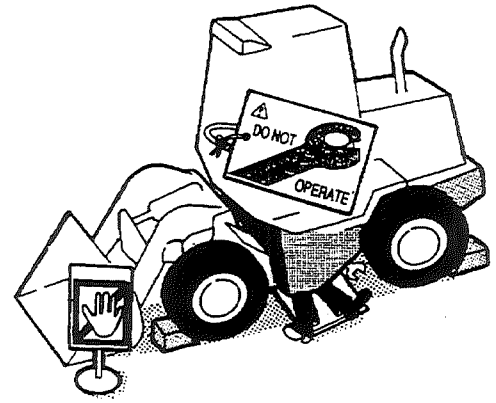

■ Check Hour Meter

Check hour meter every day to confirm time of necessary repair.

■ Genuine TCM Parts

Use Genuine TCM parts.

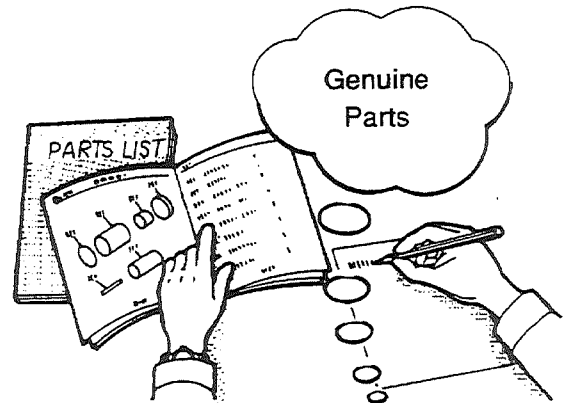

■ Lubricants

Use recommended oil or fuel only.

Use oil having specified viscosity, corresponding with atmospheric temperature.

Certain fluids, when mixed, may destroy seals causing loss of control and possible personal injury.

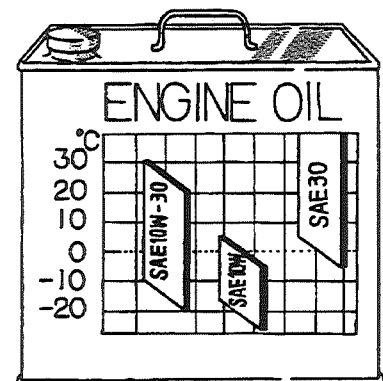

■ **Read and Obey Safety Signs**

Safety signs attached to machine provide important precautions to prevent personal injury. Read safety signs before maintenance. Replace it if damaged.

■ **Contact Your authorized Dealer**

Difficult repair, when conducted incorrectly, will cause unexpected accidents.

Contact your authorized dealer for repair engine and adjust hydraulic equipment.

Tire and rim servicing can be dangerous, and should be done by well trained personnel using proper tools and procedures. Call qualified repair service to inspect rim and tire assembly and make necessary repairs.

■ **Clean Oil and Grease**

Use clean oil and grease. Keep them in clean containers to avoid entry of dust.

■ **Pay Attention to Coolant and Oil Temperatures**

Oil, coolant, or filters are hot right after engine stop. Wait until the temperature lowers.

When replacing oil, warm oil (about 20-40°C) for easy draining.

■ **Check Drained Oil and Filters**

When replacing oil or filter, check deposit of metallic particle and foreign matter in drained oil or removed filter.

■ **Precautions for Refueling**

Do not remove strainer when refueling.

■ **Be Careful of Entry of Dust**

Checking and replacing oil should be done in place of minimum dust to avoid entry of dust.

■ **Clean Mounting Surface**

When sealed parts of O-rings, gaskets or seals are removed, clean mounting surface and replace with new sealing parts.

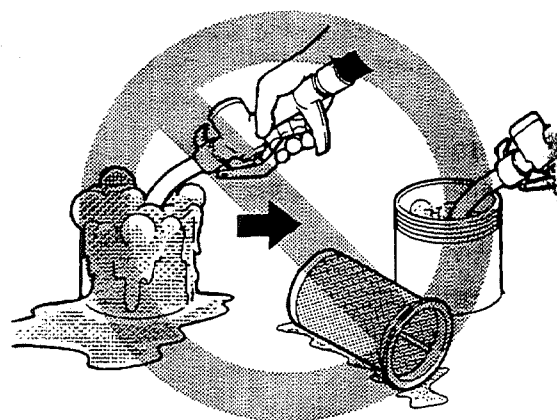
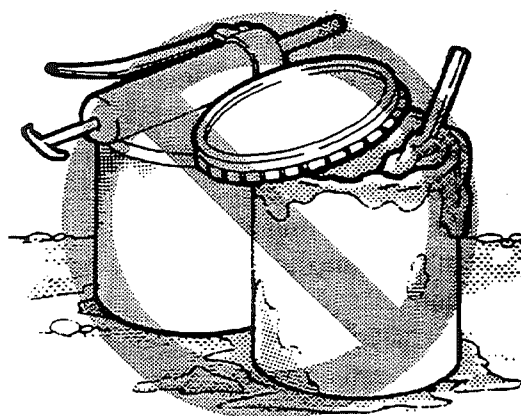

■ Use Nonflammable Oil to Clean Parts

Use nonflammable oil to clean parts. Do not use it for cleaning, gasoline is highly flammable.

■ Precautions for Welding

- Turn off starter switch.
- Do not apply 200V or higher voltage continuously.
- Take ground within 1 m from welding section.
- Do not locate seals or bearings in between weld and ground
- Remove negative(—) terminal of battery to stop flow of electricity.

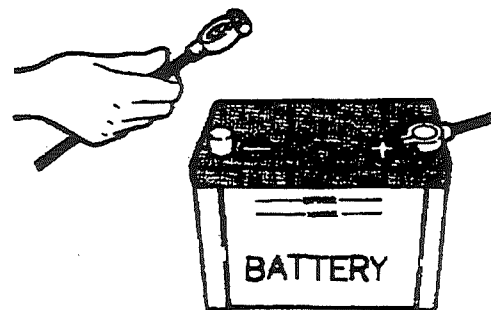

■ Air Bleeding

When oil in hydraulic oil tank or filters are replaced or when hydraulic cylinder or pipes are replaced, run engine at low speed after reassembly to bleed air from circuit.

1. Extend and retract respective cylinders 4-5 times so that they will not reach stroke end (stop cylinder travel approx. 10cm (3.9in) before stroke end).
2. Then move respective cylinders up to stroke ends 3-4 times.

When greasing, wipe away the pushed-out old grease fully. Especially on a section where the adhered sand or dust causes the increased wear of rotary unit, wipe away the old grease carefully.

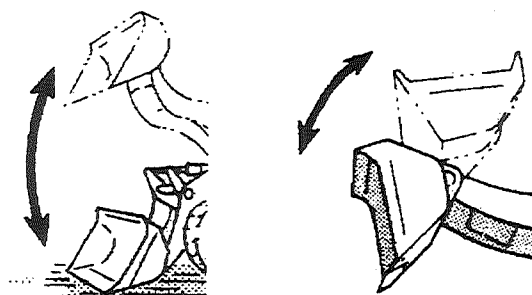

■ Precautions for Work in Dusty Place

Be careful of following when machine is operated in dusty place.

- Shorten service intervals for air cleaner element and radiator fins.
- Replace fuel filter in good time as well.
- Clean starter and alternator so that dust will not accumulate.

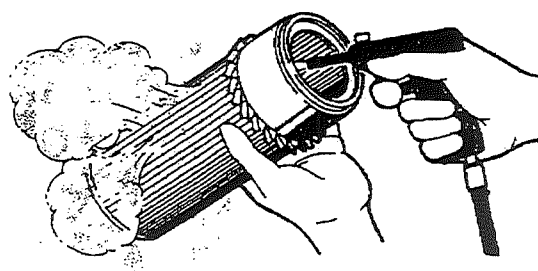

■ **Inspection of Drive Train**

When machine is operated in rocky places, inspect drive train, for cracks, wear, and damage to bolts and nuts.

■ **Keep Your Pockets Empty**

When checking open cover there is risk of dropping things in. Before removing inspection covers, empty your pockets.

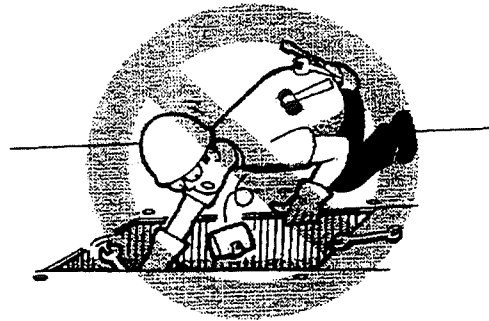

■ **Cleaning and Inspection after Work**

Thoroughly wash machine. In particular, clean filter caps, grease fittings and area around dipsticks. Do not allow entry of dirt or dust into system. Do not splash water over electrical component when washing machine. If it is soaked with water, it may not operate normally.



Periodical Replacement of Safety Parts

Replace filter elements, air cleaner elements, bolt-on edges, and other consumables with new ones in periodical inspection or before they are worn.

Replace consumables correctly to use the machine more economically.

Be sure to use the TCM genuine parts.

Check part No. with your authorized dealer when placing order for parts.

■ Consumable position

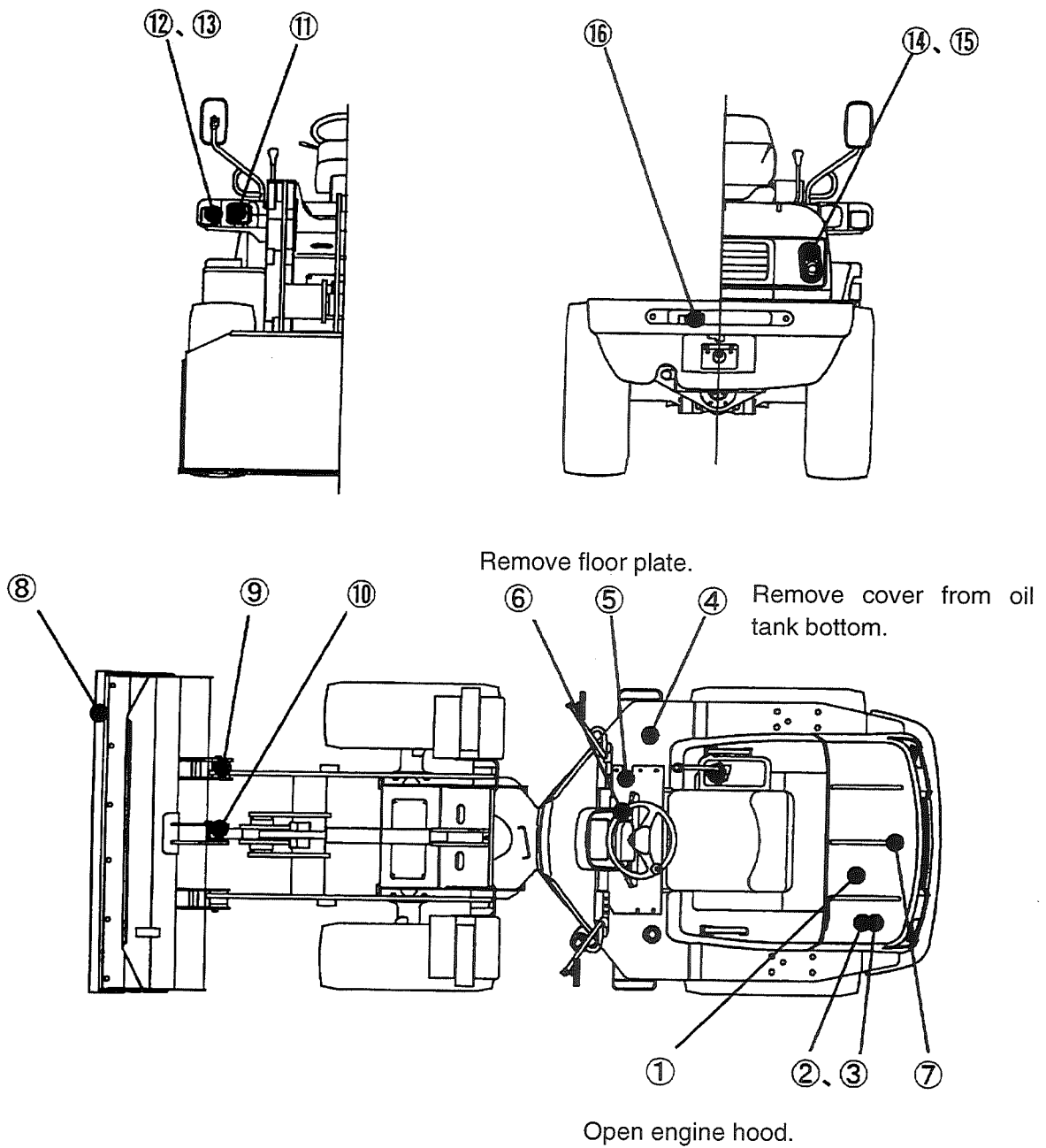

Periodical Replacement of Safety Parts

■ List of consumables

• L3-2

PARTS NAME		PARTS NO.	Q'TY	INTERVAL	
Filter/Element	① Engine oil filter	BN16271-3029-2	1	250 hours (3 months) ※	
	② Engine fuel filter element	BN16271-4356-1	1	500 hours (6 months)	
	③ Air cleaner element	HF301026-11120	1	1000 hours (12 months)	
	④ Hydraulic oil suction filter (Strainer)	HF301781-21120	1	—	
	⑤ Hydraulic oil return filter element	HF336781-31110	1	500 hours (6 months) ※	
	⑥ HST hydraulic oil filter element kit	HF301271-31130 (Element)	1	1000 hours (12 months) ※	
HF120002-06000 (O-ring)		1			
⑦ Engine fan V-belt		BN16282-9701-1	1	—	
⑧ Cutting edge (BOC)	Edge	HF301816-91110	1	—	
	Bolt	HF321811-91120	6		
	Washer	HF550811-11440	6		
	Nut	HF103312-16130	6		
Shim	⑨ Shim for adjustment between bucket and bucket link. (T: 1.0)	HF331611-15150	AR	—	
	⑩ Shim for adjustment between lift arm and bucket. (T: 1.0)	HF331611-15150	AR		
Bulb and Lens for Lamp	⑪ Head light (HF301136-53110)	Bulb	HF323121-98190	1	—
		Lens	HF301136-98110	1	
	⑫ Front turn signal indicator (HF322131-53121)	Bulb	HF322131-98130	1	—
		Lens (Front)	HF346121-98130	1	
		Lens (Rear)	HF346121-98140	1	
	⑬ Side light (HF322131-53121)	Bulb	HF322131-98140	1	—
	⑭ Rear combination turn signal light (HF323126-53110)	Bulb	HF322121-98110		
		Lens	HF323126-98110	1	
	⑮ Tail light, brake, etc. (HF323126-53110)	Bulb	HF322121-98120	1	
		Lens	HF323126-98120	1	
⑯ Back-up light (HF323126-53130)	Bulb	HF323121-98220	1	—	
	Lens	HF323126-98130	1		

※: Only at the first replacement time in a new machine, perform this work after initial 100 hours (1 month).

AR: Use shims of proper quantity depending on space.

■ List of Consumables

- L4-2

PARTS NAME		PARTS NO.	Q'TY	INTERVAL	
Filter/Element	①Engine oil filter	BN16414-3243-1	1	250 hours (3 months) ※	
	②Engine fuel filter element	BN16271-4356-1	1	500 hours (6 months)	
	③Air cleaner element	HF301126-11120	1	1000 hours (12 months)	
	④Hydraulic oil suction filter (Strainer)	HF301781-21120	1	—	
	⑤Hydraulic oil return filter element	HF336781-31110	1	500 hours (6 months)※	
	⑥HST hydraulic oil filter element kit	HF301271-31130 (Element)	1	1000 hours (12 months)※	
HF120002-06000 (O-ring)		1			
⑦Engine fan V-belt		BN16343-9701-1		—	
		BN1G790-97011	1	With 60A alternator	
⑧Cutting edge (BOC)	Edge	HF323811-91110	1	—	
	Bolt	HF321811-11420	6		
	Washer	HF550811-11440	6		
	Nut	HF103312-16130	6		
Shim	⑨Shim for adjustment between bucket and bucket link. (T: 1.0)	HF341541-11110	AR	—	
	⑩Shim for adjustment between lift arm and bucket. (T: 1.0)	HF341541-11110	AR		
Bulb and Lens for Lamp	⑪Head light (HF301136-53110)	Bulb	HF323121-98190	1	—
		Lens	HF301136-98110	1	
	⑫Front turn signal indicator (HF322131-53121)	Bulb	HF322131-98130	1	—
		Lens (Front)	HF346121-98130	1	
		Lens (Rear)	HF346121-98140	1	
	⑬Side light (HF322131-53121)	Bulb	HF322131-98140	1	—
	⑭Rear combination turn signal light (HF323126-53110)	Bulb	HF322121-98110		
		Lens	HF323126-98110	1	
	⑮Tail light, brake, etc. (HF323126-53110)	Bulb	HF322121-98120	1	
		Lens	HF323126-98120	1	
⑯Back-up light (HF323126-53130)	Bulb	HF323121-98220	1	—	
	Lens	HF323126-98130	1		

※: Only at the first replacement time in a new machine, perform this work after initial 100 hours (1 month).

AR: Use shims of proper quantity depending on space.

Periodical Replacement of Safety Parts

■ List of Consumables

- L5-2/L6-2

PARTS NAME		PARTS NO.	Q'TY	INTERVAL	
Filter/Element	① Engine oil filter	BN16414-3243-1	1	250 hours (3 months) ※	
	② Engine fuel filter element	BN16271-4356-1	1	500 hours (6 months)	
	③ Air cleaner element	HF301126-11120	1	1000 hours (12 months)	
	④ Hydraulic oil suction filter (Strainer)	HF301781-21120	1	—	
	⑤ Hydraulic oil return filter element	HF336781-31110	1	500 hours (6 months)※	
	⑥ HST hydraulic oil filter element kit	HF301271-31130 (Element)	1	1000 hours (12 months)※	
HF120002-06000 (O-ring)		1			
⑦ Engine fan V-belt	BN16343-9701-1		—		
	BN1G790-97011	1	With 60A alternator		
⑧ Cutting edge (BOC)	Edge	HF303811-91110	1	—	
	Bolt	HF321811-91120	7		
	Washer	HF550811-11440	7		
	Nut	HF103312-16130	7		
Shim	⑨ Shim for adjustment between bucket and bucket link. (T: 1.0)	HF341541-11110	AR	—	
	⑩ Shim for adjustment between lift arm and bucket. (T: 1.0)	HF341541-11110	AR		
Bulb and Lens for Lamp	⑪ Head light (HF301136-53110)	Bulb	HF323121-98190	1	—
		Lens	HF301136-98110	1	
	⑫ Front turn signal indicator (HF322131-53121)	Bulb	HF322131-98130	1	—
		Lens (Front)	HF346121-98130	1	
		Lens (Rear)	HF346121-98140	1	
	⑬ Side light (HF322131-53121)	Bulb	HF322131-98140	1	—
	⑭ Rear combination turn signal light (HF323126-53110)	Bulb	HF322121-98110		
		Lens	HF323126-98110	1	
	⑮ Tail light, brake, etc. (HF323126-53110)	Bulb	HF322121-98120	1	
		Lens	HF323126-98120	1	
⑯ Back-up light (HF323126-53130)	Bulb	HF323121-98220	1	—	
	Lens	HF323126-98130	1		

※: Only at the first replacement time in a new machine, perform this work after initial 100 hours (1 month).

AR: Use shims of proper quantity depending on space.

■ List of Consumables (Spare of Oil and Grease)

L3-2,L4-2,L5-2,L6-2

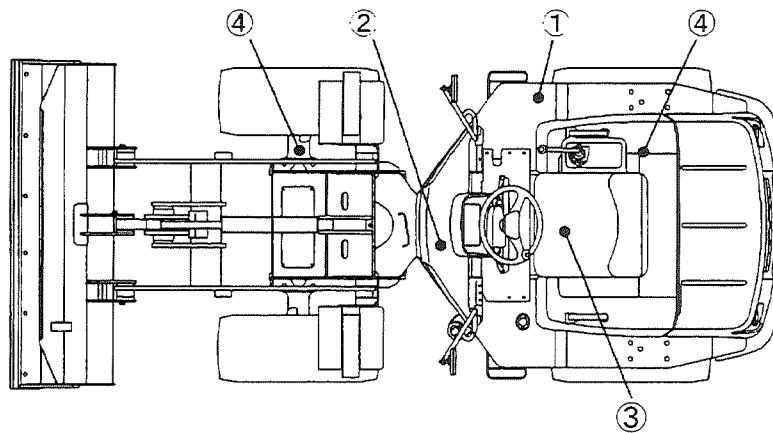

No.	Oil and Grease
1	Hydraulic oil (Nisseki Mitsubishi HP46)
2	Brake oil (Idemitsu Daphne Torque Oil B)
3	Reduction gear (Nisseki Mitsubishi Firm Gear B: Old name is Mitsubishi Antoil Super B)
4	Differential (Axle) (Cosmo Gear SAE90)
-	Grease (Cosmo Dinamax Super No. 2)

* Refer to “Fuel, Water and Lubricants Selection and Capacities” for the oil replacement quantity and interval of the machine.

Fuel, Water and Lubricants Selection and Capacities

■ Fuel

Use ONLY clean, high-quality fuel.

Use Grade No.2-D fuel above 4°C

Use Grade No.1-D fuel below 4°C

Do not use kerosene or fuel that contains gasoline or alcohol.
Use of these fuels can causes machine failure.

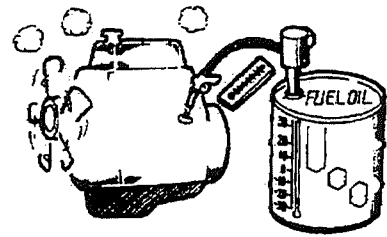

● Fuel Storage

Both injection pump and the injection nozzle, which are very precise components, are lubricated by fuel, that is, fuel oil itself. Use of fuel that contains water or dirt causes engine failure. Clean fuel must therefore be used. Handling of fuel requires strict observation of following precautions:

1. Fill fuel tank at end of operation each day. This prevents condensation of water within tank and, hence, entry of resulting moisture into fuel, and gives time for any internal dirt and moisture to separate from and settle inside tank.
2. Fill fuel storage tank and leave it for at least 24 hours, and use only supernatant after allowing any dirt and moisture to settle.
3. While filling fuel tank, do not pump up any sediment in fuel storage tank together with fuel.
4. Open drain plugs of both fuel storage tank and fuel tank of machine periodically to drain any entrapped water and sediment.
5. Replace fuel filter and element periodically.

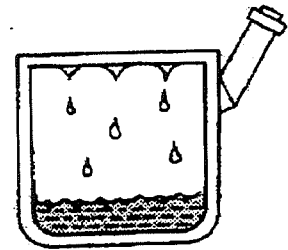

■ Grease

Use grease of NLGI No.2 for air temperatures of 0°C or more, or use grease of NLGI No.1 or No.0 for air temperatures below 0°C.

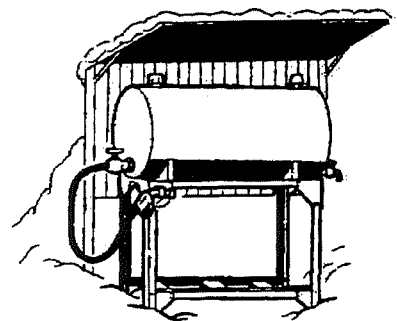

■ Lubrication Oil

- Always use engine oil of Grade CD based on API Service Classifications.
Use highly wear-resistant hydraulic oil of ISO VG46.
- Viscosity of oils changes as temperature changes. Use oils of viscosity appropriate for particular air temperature.
- Characteristics of oils vary from manufacturer to manufacturer, and use of oils of different brands in mixed form may deteriorate performance. Always use an oil of same brand to refill.
- To replace engine oil, first drain old oil completely, next flush engine with high-quality flushing oil, and then fill engine with new, high-quality engine oil.

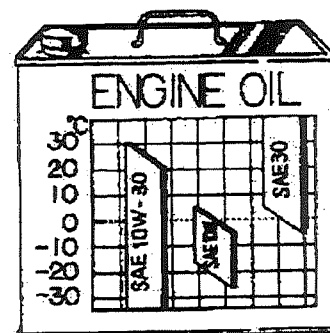

■ Coolant

Coolant should be soft water, such as tap water, that contains minimum impurities. Well water or river water must not be used. In summer, use rust-preventive agent for prevention of corrosion, and in winter, use antifreeze for prevention of freezing. When refilling is required, use coolant that contains antifreeze or rust-preventive agent and soft water at same mixing ratio as that of initial water mixture.

■ Antifreeze

- Antifreeze prevents freezing and rusting of cooling system.
- Use antifreeze when air temperature is lower than 0°C.
- Use antifreeze which can be used throughout a year. Change antifreeze every 2 years (autumn).
- When antifreeze other than antifreeze is used, replace it twice (in spring and autumn) every year.
- When coolant (antifreeze) is changed, be sure to clean cooling system.
(See “Replacement of Coolant/Cleaning of Cooling System” .)
- Freezing temperature of coolant changes according to particular mixing ratio relative to antifreeze. To set mixing ratio, assume that coolant freezes at temperatures from about 5-10°C lower than minimum level estimated. It is ideal that mixing ratio be set as directed on container of antifreeze used.

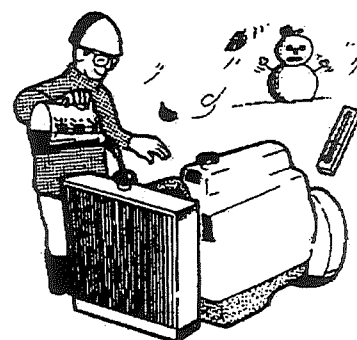
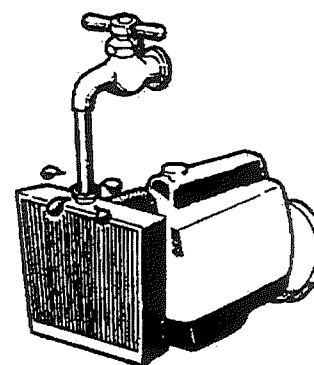

Fuel, Water and Lubricants Selection and Capacities

■ Antifreeze Mixing Ratio Table

Minimum Air Temperature (°C)		-15	-20	-25	-30	-35	-45	-55
Ratio Relative to Water (%)		30	35	40	45	50	55	60
L3-2 Cooling System Capacity [5.5L]	Amount of Antifreeze L	1.7	2.0	2.2	3.0	2.8	2.5	3.3
	Amount of Water L	3.8	3.5	3.3	3.0	2.8	2.5	2.2
L4-2 Cooling System Capacity [5.7L]	Amount of Antifreeze L	1.8	2.0	2.3	2.6	2.9	3.2	3.5
	Amount of Water L	3.9	3.7	3.4	3.1	2.8	2.5	2.2
L5-2 L6-2 Cooling System Capacity [6.1L]	Amount of Antifreeze L	1.9	2.2	2.5	2.8	3.1	3.4	3.7
	Amount of Water L	4.2	3.9	3.6	3.3	3.0	2.7	2.4

- Antifreeze must always be used at mixing ratio from 30% to 60% that is appropriate for particular air temperature. If mixing ratio is less than 30%, coolant is frozen to cause not only the damage of radiator but also low anti-corrosion power. If mixing ratio is more than 60%, the anti-freezing power is lowered and the risk of overheating is increased.
- If antifreeze comes into contact with your skin, immediately wash away it with running water.

Note:

- Coolant mixed with long life coolant (LLC) is used for new machine, so it is not necessary to change mixing ratio unless air temperature lowers to -20°C. When temperature is below -20°C, refer to "Antifreeze Mixing Ratio Table" shown above and adjust mixing ratio.

■ Applicable Oil List

IMPORTANT	
1. Characteristics of oil differ according to manufacturer, so be sure supply same oil.	
2. When a kind of oil is changed to another after overhaul, completely remove the old oil. Completely bleed air as well. When supplying oil for replenishment, be sure to supply same oil.	
3. When supplying oil of another brand name, carefully check its specifications.	
4. The oil marked with * is used as standard specification when shipped from factory.	

Engine oil	Apolloil Motive CD-M 10W-30*
Radiator (Engine coolant)	Sanshin Science Long Life Coolant DX*
Hydraulic oil	Nisseki Mitsubishi HP46*
Brake oil	Idemitsu Daphne Torque Oil B*
Reduction gear	Nisseki Mitsubishi Firm Gear B (Old name is Nisseki Mitsubishi Antoil Super B)*
Differential (Axle)	Cosmo Gear SAE90*
Grease	Cosmo Dinamax Super No. 2

■ Fuel, Water and Lubricants Application Table

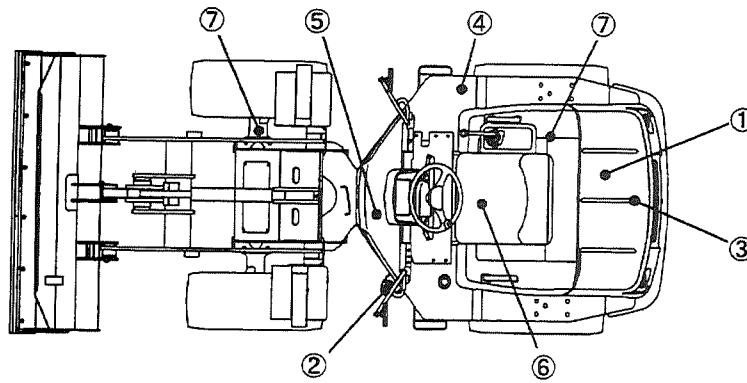

Specified Oil Level : L (gal)

Model	①	②	③	④	⑤	⑥	⑦
L3-2	3.6 (1.0)	33 (8.7)	5.5 (1.5)	18 (Total 25) (4.8(Total 6.6))	0.1(Total 0.3) (Total 0.1)	1.8 (0.5)	3.5 /EACH (0.9)
L4-2	5.6 (1.5)	50 (13.2)	5.7 (1.5)	28 (Total 42) (7.4(Total 11.1))	0.1(Total 0.3) (Total 0.1)	1.8 (0.5)	4.5 /EACH (1.2)
L5-2	5.6 (1.5)	50 (13.2)	6.1 (1.6)	28 (Total 42) (7.4(Total 11.1))	0.1(Total 0.3) (Total 0.1)	1.8 (0.5)	4.5 /EACH (1.2)

Section to be Refilled	Category and Classification	For Temperature Range						Replacement Period
		-30	-20	-10	0	10	20	
① Engine Oil Pan	Engine Oil CD-class Diesel Engine Oil	SAE5W / SAE30 SAE10W SAE10W-30						250 hours (3 months)
② Fuel Tank	Diesel fuel oil	No.1-D / No.2-D						Every day
③ Radiator	Soft Water (Tap Water)	Long Life Coolant (LLC) is added.						Every 2 years (Autumn)
④ Hydraulic Oil Tank	Anti-corrosive Hydraulic Oil	ISO VG46						1000 hours (12 months)
⑤ Brake Oil Reservoir	Torque Converter Oil SAE5W (Mineral Oil)	Torque Converter Oil SAE5W						1000 hours (12 months)
⑥ Reduction Gear	Nisseki Mitsubishi Firm Gear B or SAE10W	Special Oil or SAE10W						1000 hours (12 months)
⑦ Axle	Gear Oil	SAE80W / SAE90						1000 hours (12 months)
Pin Bearing	Lithium Multi-purpose Grease	NLGI No.1 / NLGI No.2						100/250 hours (1/3 months)

Maintenance Chart

Maintenance Interval

Check and Service Items	Page
■ Periodic Maintenance/Daily	
Walk-Around Inspection	3-16
Check Level in Engine Oil Level	3-17
Check Coolant Level	3-18
Check Hydraulic Oil Level	3-19
Check Fuel Level	3-20
Drain Water and Sediment from Fuel Tank	3-20
Drain Water and Sediment from Water Separator	3-21
Check Brake Oil Level	3-22
Check Battery Electrolyte Levels	3-23
Check and Adjust Tension of Fan Belt	3-24
Check Steering Wheel Freeplay	3-25
Check Brake Pedal Stroke	3-25
Check Tire	3-26
Check Wheel Hub Bolt for Looseness	3-26
Others	3-26
■ Periodic Maintenance/100 Hours or 1 Month (1st maintenance of new machine only)	
Change Engine Oil and Replace Engine Oil Filter	3-30
Replace Hydraulic Oil	3-42
Replace HST Oil Filter Element	3-43
■ Periodic Maintenance/100 Hours or 1 Month	
Grease Oscillating Rear Axle	3-27
■ Periodic Maintenance/250 Hours or 3 Months (First maintenance of new machine only)	
Change Axle Oil	3-45
Change Reduction Gear Oil	3-47

Check and Service Items	Page
■ Periodic Maintenance/250 Hours or 3 Months	
Change Engine Oil Replace Engine Oil Filter Element	3-30
Clean and Check Air Cleaner Element	3-32
How to Clean and Check Air Cleaner Element	3-33
Check Battery Terminals	3-34
Grease Center Pin	3-34
Grease Working Equipment	3-35
Grease Steering Pins	3-35
■ Periodic Maintenance/500 Hours or 6 Months	
Replace Fuel Filter Element	3-36
Clean Water Separator Filter Screen	3-37
Grease Propeller Shaft	3-39
Check Injection Nozzle	3-39
■ Periodic Maintenance/1000 Hours or 12 Months	
Change Hydraulic Oil and Clean Suction Strainer	3-40
Replace Hydraulic Filter Element	3-42
Replace HST Oil Filter Element	3-43
Change Axle Oil	3-45
Change Oil in Reduction Gear Oil	3-47
Change Brake Oil	3-48
Bleeding Procedure of Brake System	3-49
Replace Air Cleaner Element	3-50
■ Maintenance/When Required	
Check Axle Oil Level	3-51
Clean and Check Radiator Fin	3-52
Change Coolant and Clean Cooling System	3-53
Clean Fuel Tank	3-55
Cleaning of Engine Breather Element	3-56
Check and Adjust Engine Valve Clearance	3-56
Replace Fuses	3-57
Replace Slow Blow Fuse	3-58
Replace Cutting Edge	3-59

Periodic Maintenance/Daily

Periodic maintenance must be done before starting daily operation. You can use the machine safely and prevent trouble by performing periodic maintenance every day. This maintenance is very important. Be sure to carry out it.

■ Walk-Around Inspection

Look around and under the machine entirely to check for loose or missing bolts and nuts, leakage of oil, fuel, and coolant, as well as their spill on ground.

Check condition of tire pressure, working device and hydraulic system.

- ① Check bucket and linkage for damage and excessive wear.
- ② Check high-pressure hoses, their connections and hydraulic cylinders for oil leakage.
- ③ Check lights for broken bulbs and lenses.
- ④ Check cooling system for leakage and radiator for clogging.
- ⑤ Check engine room for oil or fuel leakage. Check battery electrolyte level.
- ⑥ Check the steps and handrails for damage, oil or mud. Oil or mud may cause slip.
- ⑦ Watch bottom of machine body and check if oil leaks from front and rear axles and if dust or mud is accumulated.
- ⑧ Check HST and piping for oil leakage.
- ⑨ Check hydraulic system for oil leakage.
- ⑩ Check tires for damage and pressure.
- ⑪ Check if operator's seat and its vicinity are fully cleaned.
- ⑫ Check monitors and meters on the meter panel for damage.

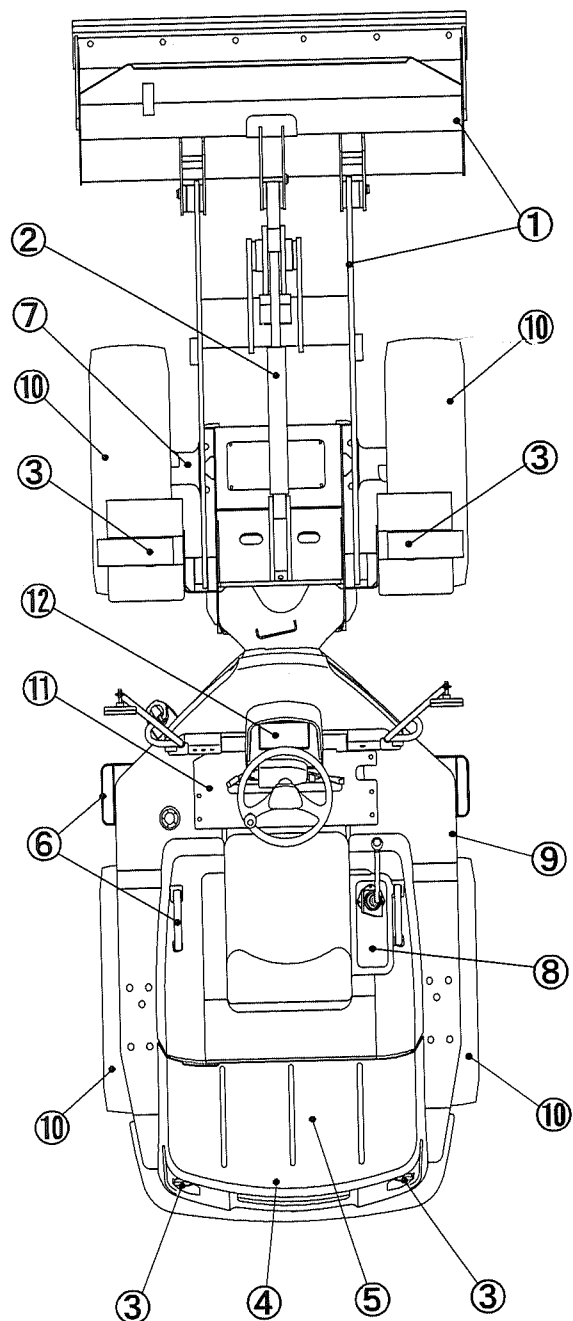

■ Check Engine Oil Level



WARNING

If oil has spilled during Add, wipe it away fully. The spilled oil may cause fire.

IMPORTANT

- Wipe well area around oil filler port to prevent dust.
- Check oil level 5 minutes after Add. If check is done right after Add, lower oil level is displayed than real level to cause excessive Add.
- Use engine oil with proper viscosity according to ambient temperature.

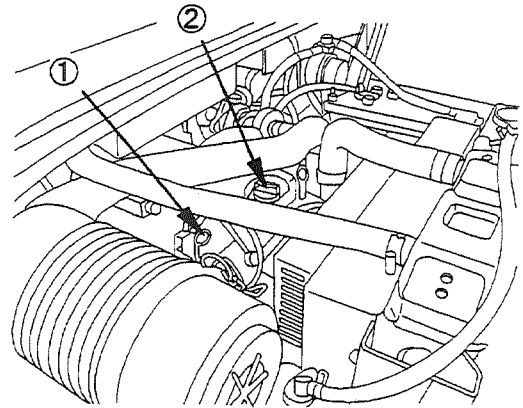

Stop machine on a level ground and then check oil level before starting engine. If engine has started, stop it and wait for at least 5 minutes before rechecking level.

1. Open engine hood.
2. Remove dipstick ① and wipe it with clean cloth. Insert it again completely, and take it out slowly. Check oil level. (Check for oil contamination and viscosity.)
3. Engine oil level is appropriate if it is between high and low lines inscribed on the gauge.
4. If engine oil is insufficient, Add it through oil filler port ②.

■ Check Coolant Level

! WARNING

- Normally, don't remove radiator cap. If you have removed radiator cap when engine is hot, steam or hot water spouts to burn you.
- Check coolant level at reservoir tank only when engine is cool.

IMPORTANT

- Supply coolant with same mixing ratio of antifreeze and anticorrosive as before.
- **DO NOT** use well water or river water as coolant. Use soft water such as tap water.

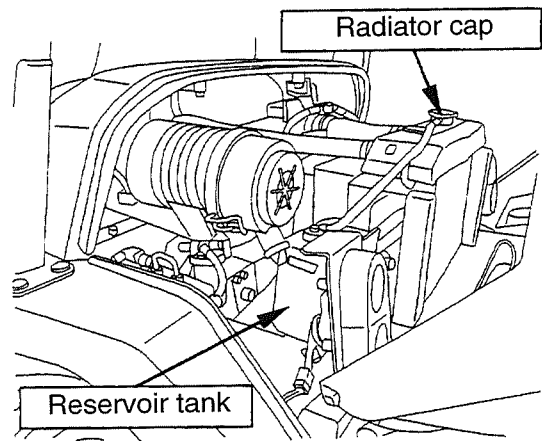

Reservoir tank is located at left side in engine room.

1. Check coolant level in radiator while engine stops and the coolant temperature is low.
2. Coolant level is appropriate if it is between **FULL** and **LOW** lines on reservoir tank. If level is **LOW** or less, open cap at top of reservoir tank and add coolant up to **FULL**. If reservoir tank is empty, remove radiator cap and add coolant to top of radiator.
3. If coolant decreases constantly, check radiator and radiator hose for leakage.

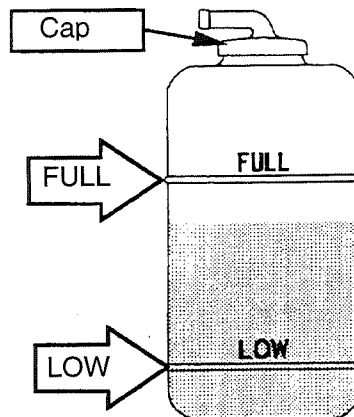

■ Check in Hydraulic Oil Level



WARNING

- The hydraulic oil tank has internal pressure. Especially right after operation, the hydraulic oil tank is hot. Before removing the oil filler port plug, make sure that the tank is cooled down and relieve the internal pressure.

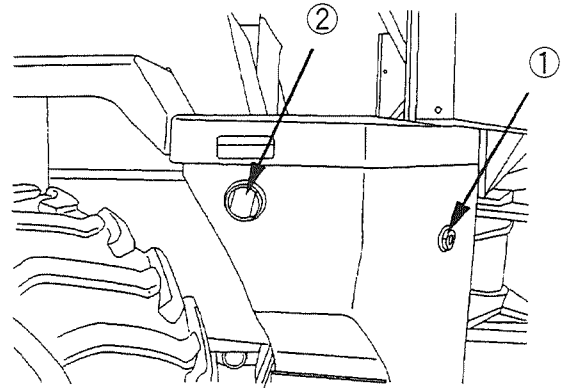

Hydraulic oil tank is located right side of machine.

1. Park machine straight on a level ground, put bucket on ground horizontally and stop engine.
2. Check the oil level with the oil level gauge ① located on side of tank.
3. Oil level is appropriate if it is between High and Low lines on sight gauge.
4. If oil level is insufficient, remove oil filler port plug ② (Open end wrench size: 32mm) and Add specified hydraulic oil. (Refer to “Applicable Oil Lists” .)
5. Firmly install oil filler port plug ②.

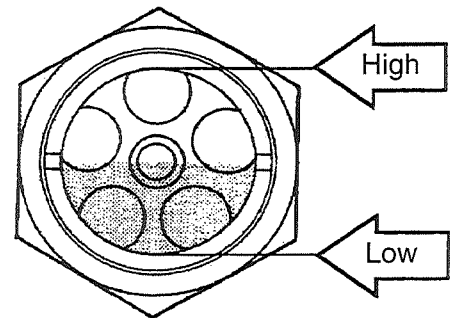

■ Check of Fuel Level

WARNING

- Fuel (light oil) is flammable. Stop engine before fill tank. Do not smoke while you fill fuel tank or work on fuel system.
- If oil has spilt during supply, spilt oil may cause fire. Wipe it away fully.

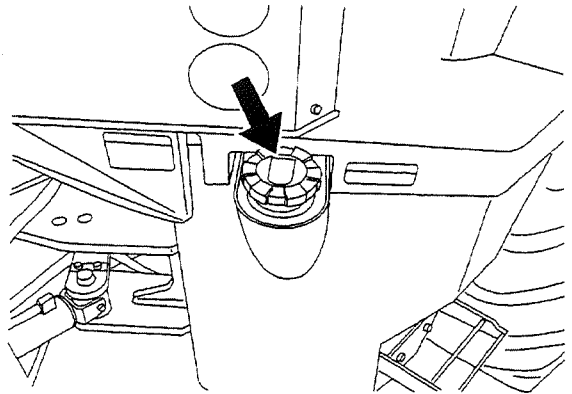

Fuel filler port is located on left of machine.

1. Before starting engine, use fuel gauge to check quantity of fuel in tank.
2. While filling fuel tank, do not allow water or dirt to enter. Also, leave strainer of fuel tank mounted.
3. Securely tighten and lock cap after filling up fuel tank.

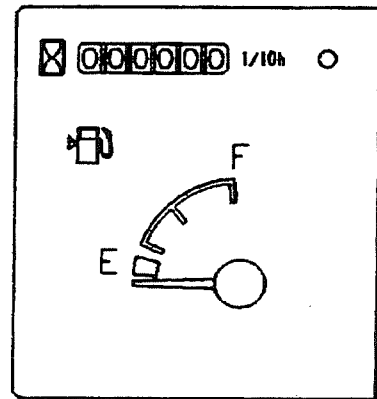

Fill fuel tank after work.

Model	Fuel tank capacity L(gal)
L3-2	33(8.7)
L4-2	50(13.2)
L5-2	50(13.2)
L6-2	50(13.2)

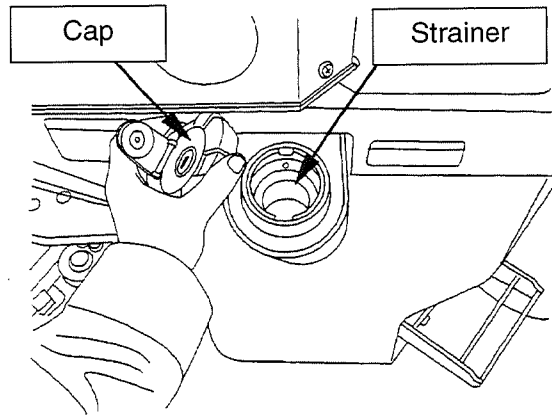

■ Drain of Water and Sediment from Fuel Tank

Remove plug (width across flat: 19mm) to drain water and sediment from fuel tank. Install plug after draining.

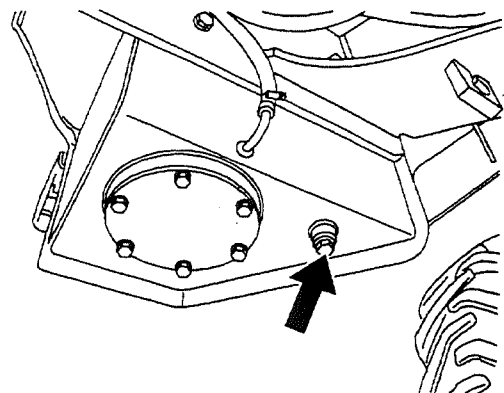

■ **Drain Water and Sediment from Water Separator**

Water separator filter separates water mixed with fuel to prevent trouble due to water.

Accumulated water lifts up “float” in the filter case.

Accumulated water lifts up float in filter case. When Float reaches “Drain Level”, loosen retaining ring and remove filter case to discharge water and sediment.

Discharge water according to “Clean Water Separator Filter Screen”.

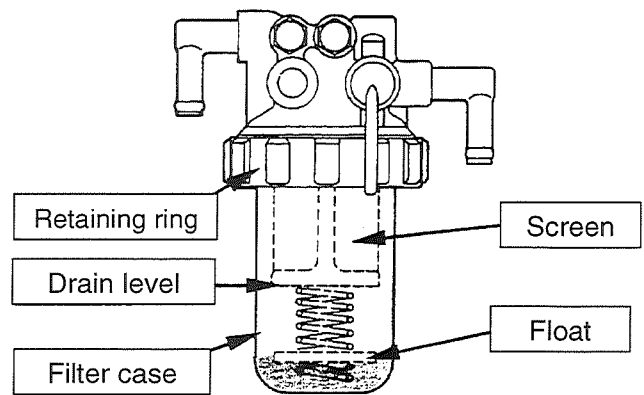
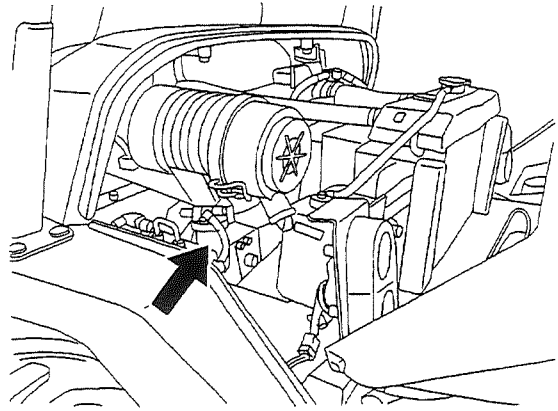

■ Check Brake Oil Level



WARNING

- Use specified brake oil. Don't use automotive tyep brake fluid.
- When brake oil level drops quickly, check master cylinder and brake piping for leakage.

IMPORTANT

When adding brake oil, be careful to prevent foreign matter from entering.

Brake oil tank is located at back of steering cover.

1. Check oil level in brake oil reservoir.
2. Check visually or by touching if oil leaks around reservoir.
3. Oil level must be within the range of brake oil reservoir (A).
4. If brake oil level is insufficient, remove cap from brake oil reservoir and add specified oil to reach a proper level.
5. After adding, install cap firmly.

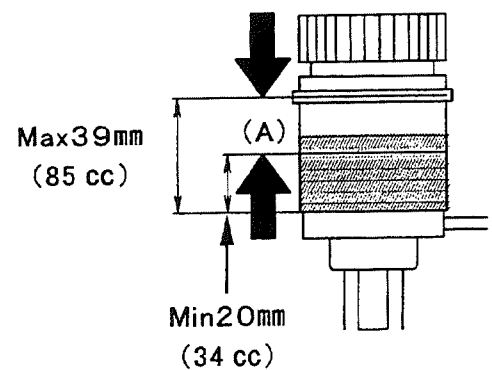
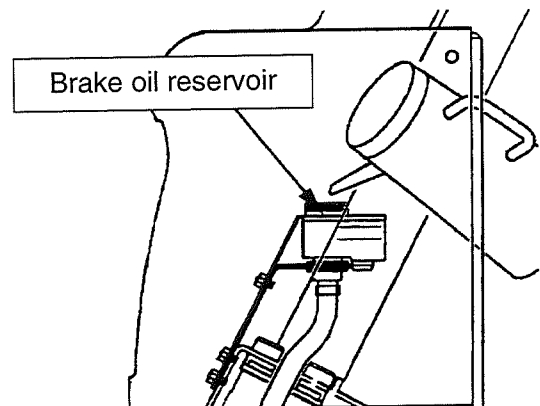
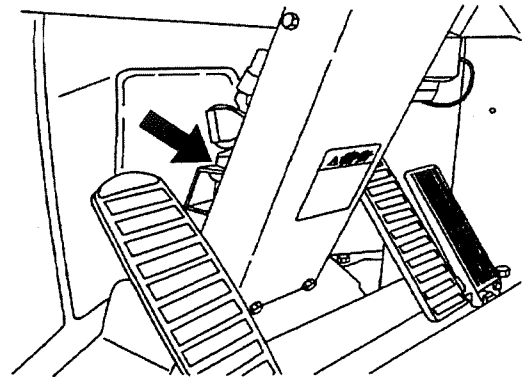

■ Check of Battery Electrolyte Level

! WARNING

Battery gas can explode. Do not smoke when observing battery electrolyte levels.

Electrolyte is dilute sulfuric acid solution, so avoid contact with eyes, skin, clothing or other metallic surfaces. If it should get onto anything, wash it off quickly with running water and wash it off quickly with a doctor.

Always keep battery surface clean and ventilation holes free from dirt.



Battery is located at right side in engine room.

For battery that has level lines marked on side, liquid level must be between **UPPER** and **LOWER** level lines.

Add distilled water up to **UPPER** level line if necessary.

For battery that does not have level line marking, or When level check is impossible, remove cap and check visually filler port. Level is appropriate if it reaches sleeve bottom.

Add distilled water up to sleeve bottom if necessary.

For battery that has indicator, follow the instruction.

While freezing weather, add distilled only just before operation or just before changing.

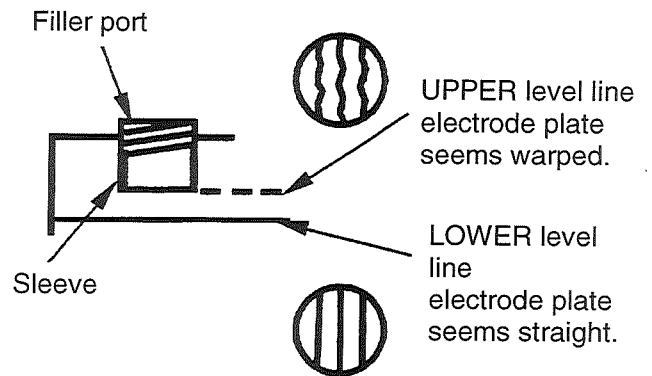
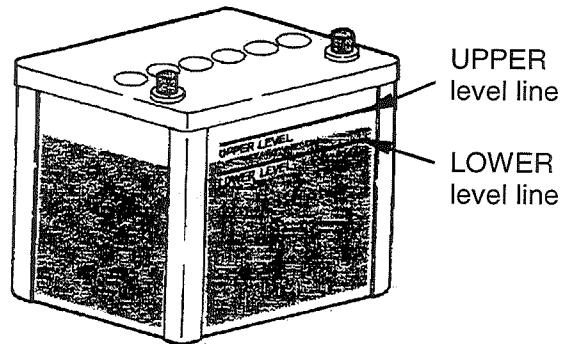

! DANGER

Do not use or charge battery while battery electrolyte is at or below **LOWER** level line.

- Battery life will be shortened. Moreover, explosion may occur.
- Electrolyte may leak to corrode parts or damage the painted surface.

■ Check and Adjust Tension of Fan Belt

! WARNING

DO NOT check and adjust fan belt while engine is running.

IMPORTANT

- Excessive belt tension damages belt and bearing.
- DO NOT oil or lubricate belt. Belt will slip to shorten its life.
- Check pulleys for damage, as well as groove and belt for abrasion. Check to see if belt is in contact with bottom of groove.
- If belt is elongated to lose adjusting allowance, is cracked or damaged, replace it. When belt has been replaced, check the belt tension again after operation.

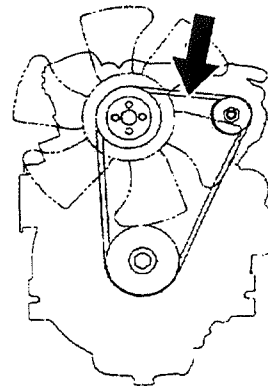
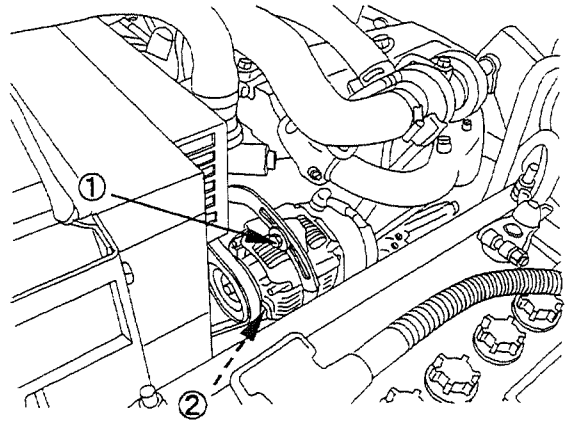

Check fan belt for looseness and damage.

1. Push middle portion between fan pulley and alternator pulley at finger pressure of approx. 98N (10kg) and check that flexure belt.

Model	Flexure (in/mm)
L3-2	0.31-0.39/8-10
L4-2	0.31-0.39/8-10
L5-2	0.39-0.59/10-15
L6-2	

2. If belt needs adjustment, loosen bolt ① and lock nut, ② move alternator and adjust flexure of belt. Don't push alternator directly with steel bar, etc. but push it via a wood piece, etc.
3. After adjustment, tighten the bolt and nut securely.

■ Check Steering Wheel Freeplay

IMPORTANT

When freeplay is excessive or steering wheel does not turn smoothly, contact your authorized dealer.

Check to see if freeplay of steering wheel is appropriate and if its operation is normal. Freeplay should be 20 – 40 mm (0.8 – 1.5 in) on circumference of steering wheel.

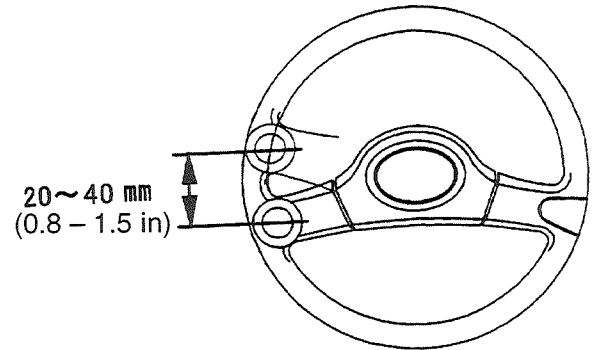

■ Check Brake Pedal Stroke

! WARNING

When stroke is long or resistance of pedal is weak, there is possibility of brake oil leakage or poor braking operation because air is mixed. Contact with your authorized dealer.

Depress brake pedal completely to see if stroke is appropriate [approx. 50mm(1.9in)] or if resistance is sufficient when you depress pedal to maximum extent,

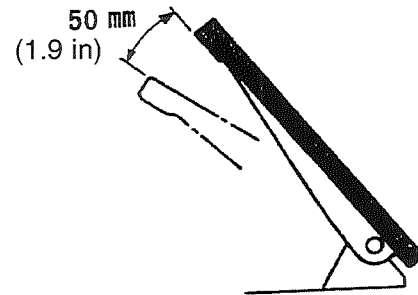

■ Check Tires

Measure tire pressure with gauge while tires are cool.

At the same time as inspection of tire pressure, check tires for nails, metal pieces, or chips of rock that may cause flat tires or for abnormal wear, cracks, and other damage.

■ Check Wheel Bolts for Looseness

Check wheel hub bolts for looseness. Be sure to turn bolts in tightening direction for inspection. If broken wheel hub bolt is found, change all wheel hub bolts.

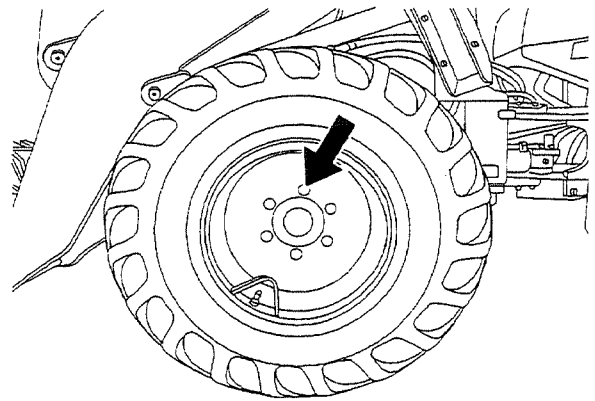
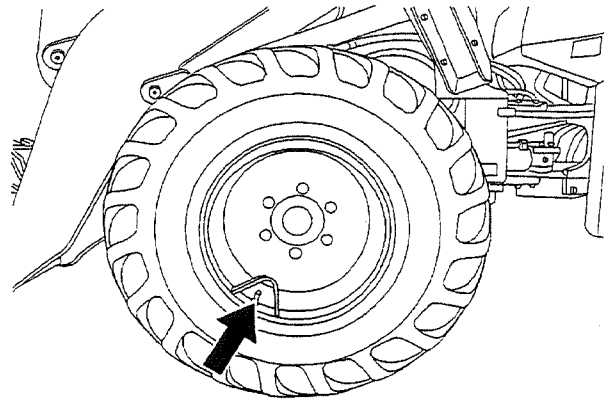

Model	Tire pressure (Standard tire) Kpa (PSI)	Tightening torque N·m (ft·lb)
L3-2	196 – 215 (28 – 31)	273 – 300 (201 – 221)
L4-2	196 – 215 (28 – 31)	375 – 412 (227 – 304)
L5-2	215 – 235	375 – 412
L6-2	(31 – 34)	(227 – 304)

■ Others

- Check for correct serving of any abnormal sections that might have been found whiel operations on previous working day.
- Check for operation of electronic-monitoring system, coolant temperature gauge, and other instrument.
- Check that each control lever can be easily actuated and that they operate without backlashes.
- Check that head light, rear work light, backup light and turn signal light correctly operate. Depress brake pedal to see if brake light comes on.
- Check that horn sound.
- Sit up in operator’s seat, and check to see if rear view mirror is in position sufficiently showing condition of rear and side.
- Check engine for sound, vibration, and color of exhaust gas.
- Check that reflector and license plate are not dirty or damaged, permitting clear identification.

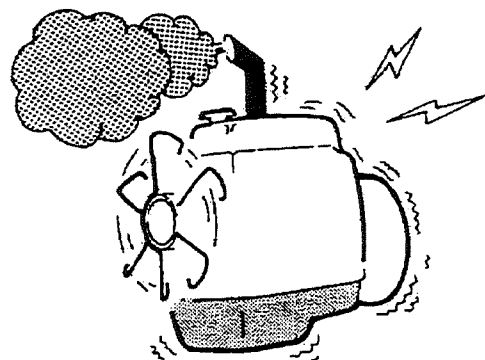
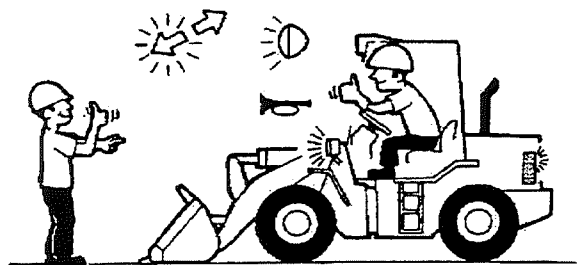

Periodic Maintenance/100 Hours or 1 Month

■ Grease Oscillating Rear Axle

- ① Rear axle support (Front side)
- ② Rear axle support (Rear side)

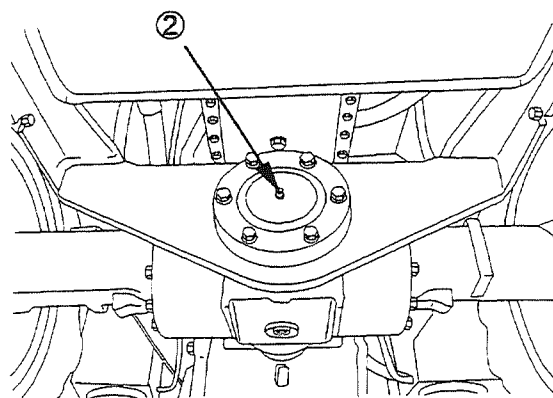
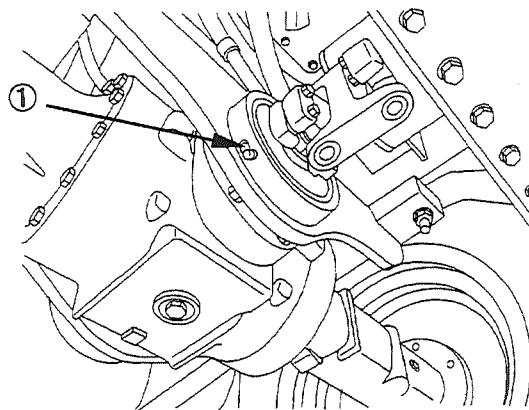

■ Cleaning of Fuel Filter Element

WARNING

- Each section is hot right after engine has stopped. Wait until each section is cooled down before cleaning fuel filter.
- Don't put fire near the machine.
- The spilt fuel may cause fire. Wipe it off completely.
- Before cleaning or replacing the fuel filter, set the starter switch to "OFF" or disconnect the earth side of battery.
- When cleaning with compressed air, wear protective glasses. Use the compressed air of 200Kpa (30PSI) or less.

IMPORTANT

Don't use gasoline to clean the filter element.

Fuel filter separates and removes sediment and moisture from fuel. Fuel filter may become clogged with foreign substances during a long time operation. Fuel filter must be cleaned at fixed intervals to prevent such clogging.

1. Turn the cock ① of fuel filter upward to "Close".
2. Remove the retaining ring ② and take out the element [4] from the filter case ③.
3. Clean the element ④ with light oil and inject the compressed air 200Kpa (30PSI) from the inside of the element to remove dust.
4. Also remove dust and moisture from the bottom of filter case ③.

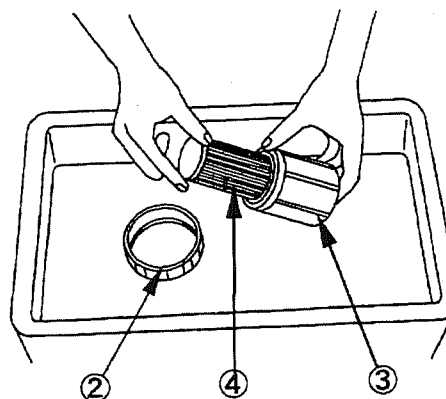
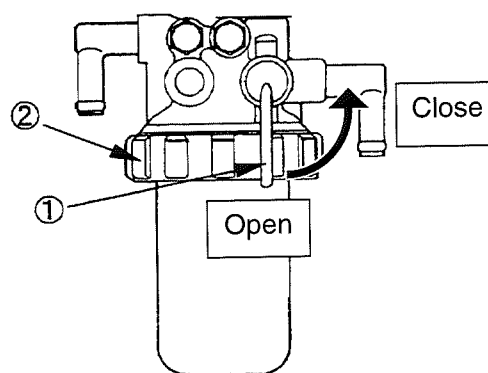
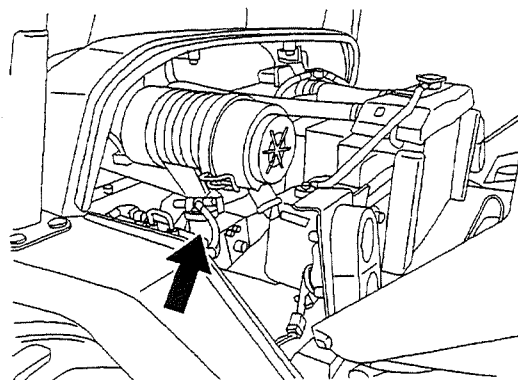

5. Check the O-ring. If it is damaged, replace it with a new one.
6. Install the cleaned element ④ to the filter case ③ and set them on the filter mounting by hand. When the packing surface is in contact with the seal surface of filter mounting, tighten the retaining ring by about 2/3 turn manually. Don't tighten the retaining ring excessively.
7. Turn the cock ① of fuel filter downward to "Open".
8. After installing, bleed air from the fuel system and check for fuel leakage.

Bleed Air fuel system

These machines are equipped with an electric fuel pump. Set starter switch to "ON", and air will be removed automatically. It is not necessary to run starter motor.



WARNING

Before starting engine, make sure of safety around engine and then crank up.

IMPORTANT

Shortage of fuel and suction of air will make the electric fuel pump empty, causing a loud suction sound (operating sound). Turn OFF the starter switch to avoid the empty pump.

Conduct following operations 100 hours (1 month) after initial operation of new machine.

- Change HST Oil Filter Element
- Change Engine Oil and Replace Filter Element
- Replace Hydraulic Return Filter Element

Periodic Maintenance/250 Hours or 3 Months

At the same time carry out "Periodic Maintenance/100 Hours or 1 Month".

■ Change Engine Oil and Replace Filter Element

CAUTION

Oil is hot right after engine is stopped. Wait until oil cools before changing oil.

Spilt engine oil will cause fire, wipe it off completely.

IMPORTANT

DO NOT reuse oil filter.

Drain plug ① is located at underside on right side of rear of machine.

1. Open engine hood.
2. Place containers under drain plug ① and oil filter ② to receive drained oil.
3. Remove drain plug ① (wrench size: 19mm) to drain oil. After draining, tighten the drain plug ①.
4. Turn oil filter ② counterclockwise to remove it. If it cannot be easily removed, use a filter wrench.
5. Apply oil thinly to packing surface of a new oil filter.
6. Clean filter mounting and install a new oil filter by turning it clockwise. When seal surface of packing is in contact with seal surface of filter mounting, tighten oil filter by about 2/3 turns. If tightened excessively, packing is damaged to cause oil leakage. Be careful not to tighten oil filter excessively.

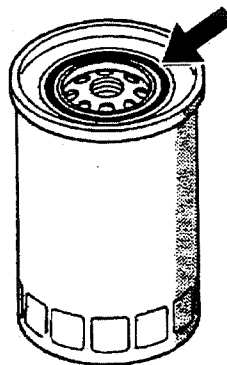
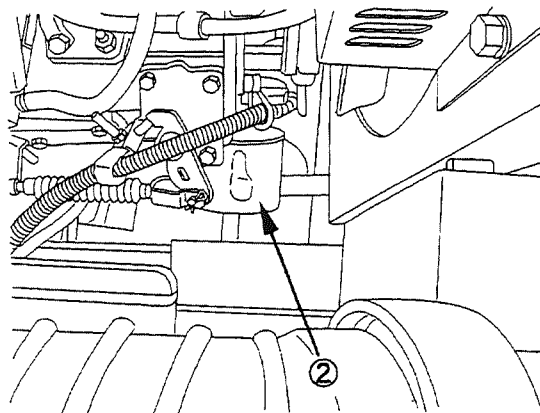
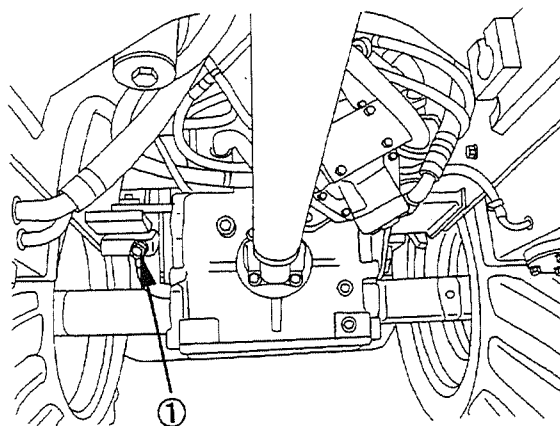

7. Supply required quantity of engine oil appropriate for particular air temperature from filler port ③. (See “Applicable Oil Lists”.)

Model	Required oil q'ty
L3-2	3.6 liter (0.95 gal)
L4-2	5.6 liter (1.48gal)
L5-2	5.6 liter (1.48 gal)
L6-2	5.6 liter (1.48 gal)

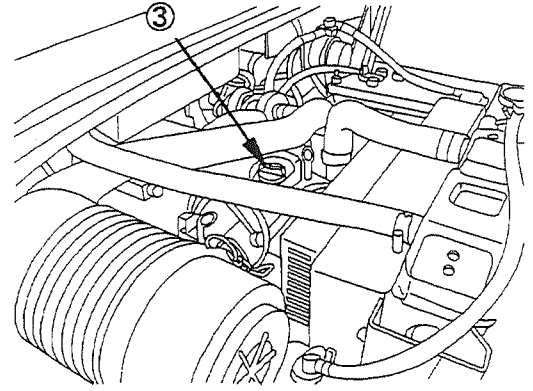

8. Run engine at low idle. Make sure that the engine oil does not leak.
9. 5 to 10 minutes after engine has stopped, check engine oil level again. Refer to “Check Engine Oil Level”.

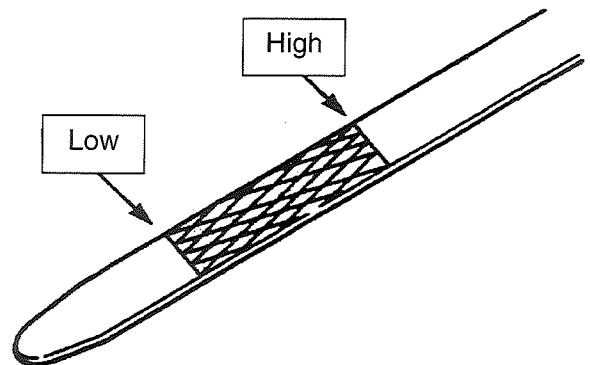

Replace engine oil and filter element after initial 100 hours (1 month) operation. Thereafter replace them every 250 hours (3 months) operation.

Periodic Maintenance/250 Hours or 3 Months

■ Clean and Check Air Cleaner Element



CAUTION

DO NOT clean and replace the air cleaner while engine is running.

IMPORTANT

Stop engine before servicing air cleaner.

If machine is to be operated in dusty places, shorten service interval.

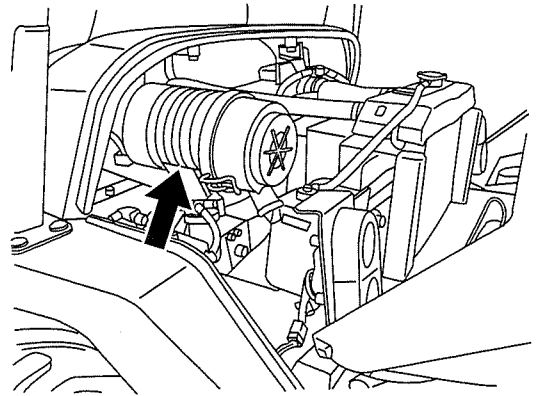

Clean and check air cleaner element every 250 hours (3 months) or if air cleaner dust indicator lamp comes on.

1. Release clamps and remove dust cup.
2. Take out element, and clean and check it. Refer to “**Clean and Check Air Cleaner Element**”.
3. Clean the body interior with a clean cloth.
4. Install a new or cleaned element.
5. Clean dust cup and then install and fix it with clamp securely. Install the dust cup to face its assembly direction indicator mark (TOP) upward.
6. Check air piping for looseness of hose clamps, etc.

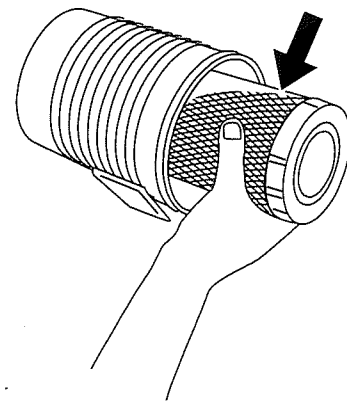

NOTE

*If cleaned element is installed and soon indicator lamp is lit, replace it with a new element.
It is permitted to clean an element up to 5 times.
If the element is to be cleaned 6 times, replace it with a new one.*

■ How to Clean and Check Air Cleaner Element

IMPORTANT
When cleaning element, DO NOT tap and hit it against hard objects. DO NOT use an element whose plaits and gasket are damaged.

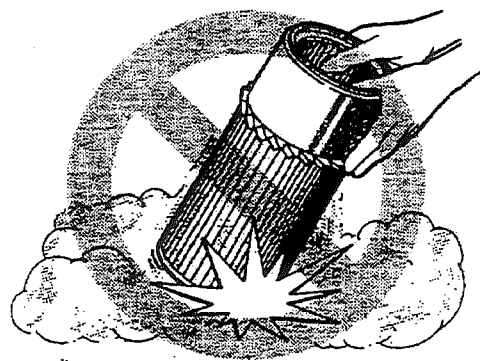

Cleaning

Clean element in the following way according to degree of its contamination.

■ Clean Dusty Element

 CAUTION
When cleaning element with compressed air, wear protective glasses and use compressed air of 200Kpa (30 PSI) or less.

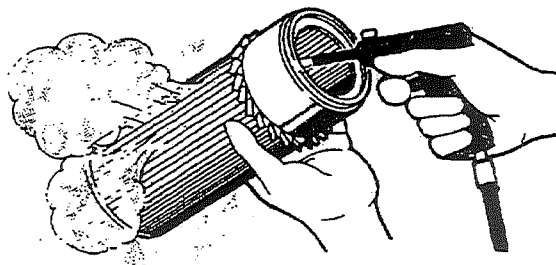

IMPORTANT
DO NOT wash the element with water.

Inject dry, compressed air of 200Kpa (30 PSI) from inside of element along fins.

Check

Perform checks after element has been cleaned. Illuminate inside of element from top, and check filter paper. Replace element with new one if filter paper is damaged or has pinholes, especially, thin section, or if gasket is damaged.



Periodic Maintenance/250 Hours or 3 Months

■ Check Battery Terminals

Check terminals for looseness. Clean them if they are dirty or corroded.

When terminals are corroded and white powder is adhering, clean them with hot water.

If corrosion is excessive, brush terminals. After cleaning, apply grease thinly to terminals.

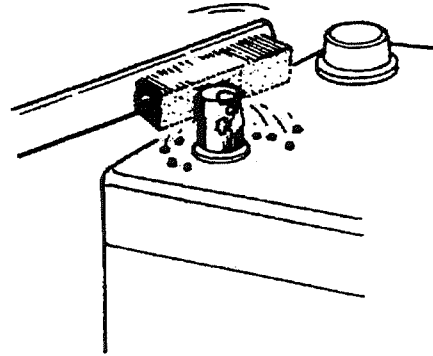

■ Grease Center Pin

Use clean grease to prevent dust from entering. After lubrication, wipe off the drained old grease completely.

① Center pin (left side)

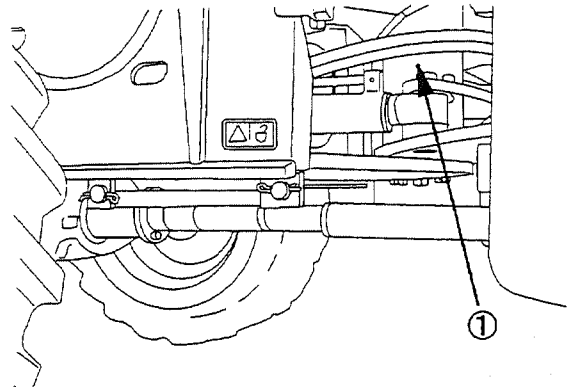

■ Grease Working Equipment

Use a clean grease to prevent dust from entering. After lubrication, wipe off the drained old grease completely. Especially if the bucket hinge pin and bucket link pin are soiled with sand or dust, they are worn early. Carefully wipe them.

● HN bush

HN bushes are being used for these machines. As pin moves (generates friction heat), the oil in this bush is sucked into the clearance against pin and oozes. Consequently excellent lubricating performance is obtained to prolong the greasing interval and besides reduce the wear of pin and bush remarkably.

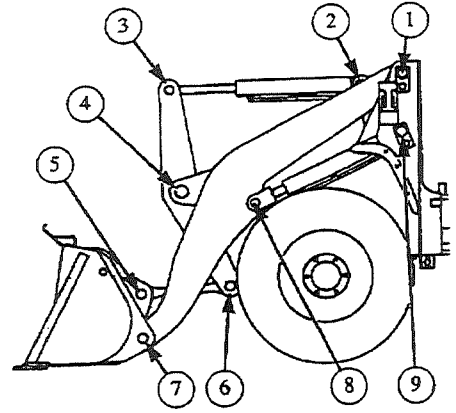

- ① Lift arm pin (RH&LH, 2 places)
- ② Bucket cylinder pin
- ③ Bucket cylinder pin
- ④ Bell crank pin
- ⑤ Bucket link pin
- ⑥ Bucket link pin
- ⑦ Bucket hinge pin (RH&LH, 2 places)
- ⑧ Lift cylinder pin (RH&LH, 2 places)
- ⑨ Lift cylinder pin (RH&LH, 2 places)

■ Grease Steering Pin

- ① Steering cylinder pin(Front)
- ② Steering cylinder pin (Rear)

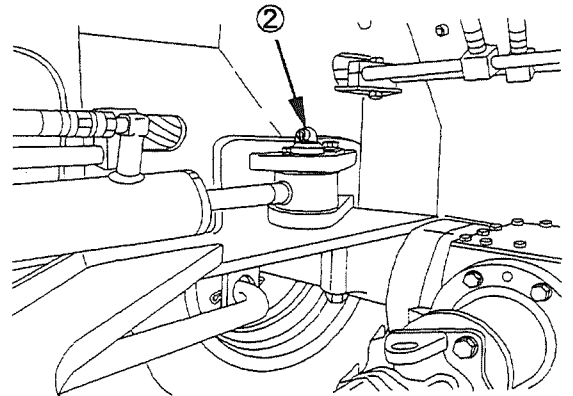

Conduct the following operations 250 hours (3 months) after initial operation of new machine only.

■ Change Axle Oil and Reduction Gear Oil

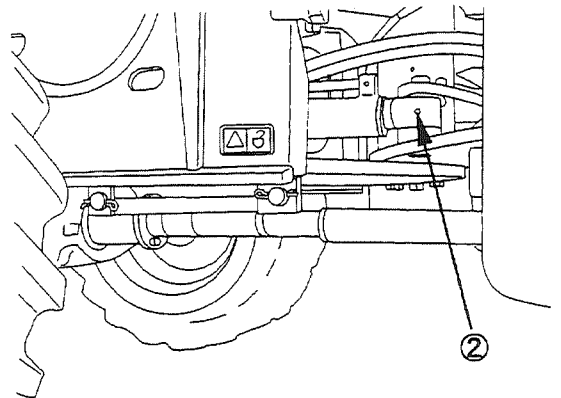

Periodic Maintenance/500 Hours or 6 Months

At the same time carry out “Periodic Maintenance/100 Hours or 1 Month” and “Periodic Maintenance/250 Hours or 3 Months”.

■ Replace Fuel Filter Element



WARNING

Each section is hot right after engine has stopped. Wait until each section is cooled down before replacing fuel filter.

DO NOT put fire near machine.

Spilt oil may cause fire. Wipe it off completely. Before replacing fuel filter, set starter switch to “OFF” or disconnect ground harness of battery.

When cleaning with compressed air, wear protective glasses. Use the compressed air of 200Kpa (30 PSI) or less.

IMPORTANT

DO NOT use gasoline to clean part.

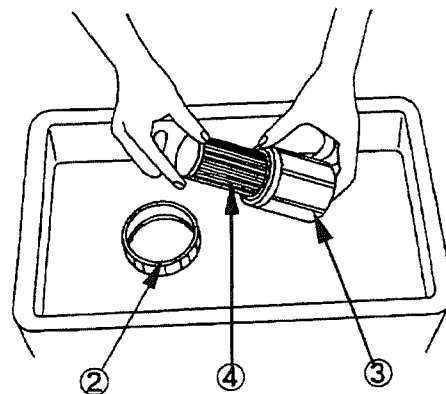
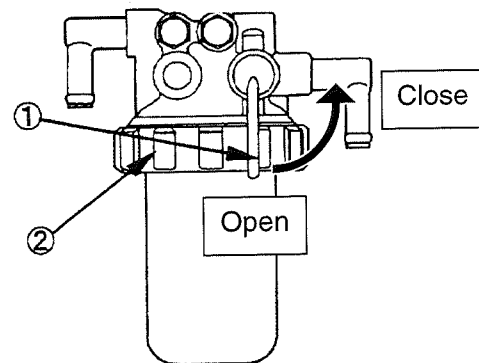
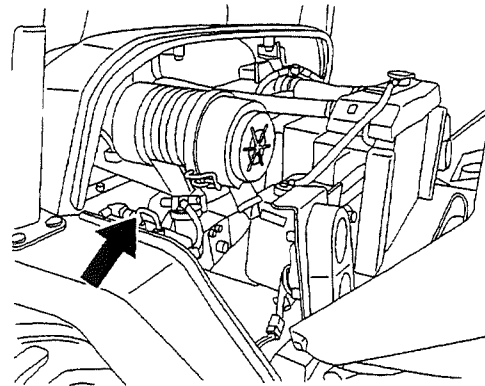

Fuel filter separates and removes sediment and moisture from fuel. Fuel filter may become clogged with foreign substances during a long time operation. Fuel filter must be replaced at fixed intervals to prevent such clogging.

1. Turn cock ① of fuel filter counter clockwise to “Close”. Turn ① in 90°.
2. Remove retaining ring ② and take out element ④ from filter case ③.
3. Filter case ③ with and install a new element. At the same time replace the O-ring with a new one.
4. Clean filter mounting and install new element. When installing, be careful not to twist and damage the packing.
DO NOT tighten retaining ring excessively.
5. Turn cock ① clockwise to open.
6. Bleed air fuel system and start engine to check filter seal for leakage.

Memo

A series of horizontal dotted lines for writing, starting below the title and extending across the page.

No. OW-600AE

ISSUED: JANUARY, 2002

TCM CORPORATION

INTERNATIONAL MARKETING DIVISION:

1-15-5, Nishi-shimbashi, Minato-ku, Tokyo
105-0003, Japan
FAX: Japan +81-3-35918152, 3-35918153

All rights reserved

OT-1406007(TA) Printed in Japan

■ Clean Water Separator Filter Screen

WARNING

Each section is hot right after engine has stopped. Wait until each section is cooled down before replacing water separator filter.

DO NOT put fire near the machine.

Spilt fuel may cause fire. Wipe it off completely.

Before cleaning or replacing water separator filter, set starter switch to "OFF" or disconnect ground harness of battery.

When cleaning with compressed air, wear protective glasses. Use the compressed air of 200Kpa (30 PSI) or less.

IMPORTANT

DO NOT use gasoline to clean screen.

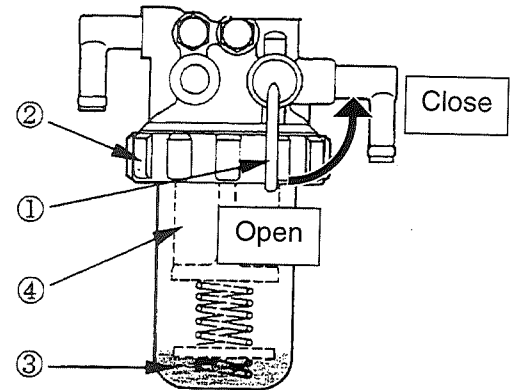
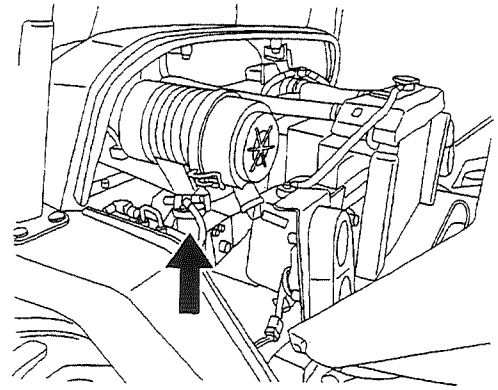

Water separator filter separates water from fuel to prevent trouble due to water. Water separator filter may become clogged with foreign substances during a long time operation. Water separator filter must be cleaned at fixed intervals to prevent such clogging.

1. Turn cock ① of water separator filter counter clockwise to "Close". Turn cock ① in 90°.
2. Remove retaining ring ② and then remove filter case ③ and screen ④.
3. Wash screen ④ with clean fuel oil and inject compressed air of 200Kpa (30 PSI) from inside to remove substances.
4. Also remove dust and water accumulated in bottom of filter case ③.

Periodic Maintenance/500 Hours or 6 Months

5. Check O-ring. If it is damaged, replace it with a new one.
6. Clean water separator mounting surface. Install cleaned screen ④ to filter mounting. Set spring ⑤ and float ⑥ to filter case ③ and install them on filter mounting. When installing, be careful not to twist and damage O-ring.
7. Turn cock ① clockwise to "Open".
8. Bleed air fuel system and start engine to check fuel leakage.

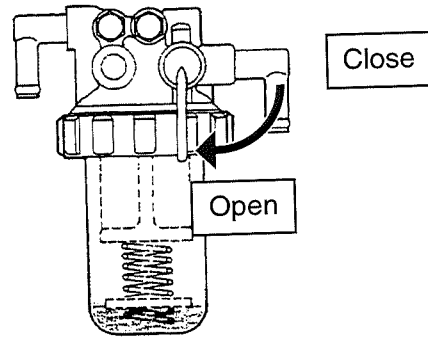

Bleed Air fuel system

These machines are equipped with an electric fuel pump. Set starter switch to "ON", and air will be removed automatically. It is not necessary to run starter motor.



WARNING

Before starting engine, make sure of safety around engine and then crank up.

IMPORTANT

Shortage of fuel and suction of air will make the electric fuel pump empty, causing a loud suction sound (operating sound). Turn OFF the starter switch to avoid the empty pump.

■ Grease Propeller Shafts

WARNING
 Stop engine on level surface. Lower bucket to ground, then apply parking brake. Make sure place chocks against tires to prevent moving.

1. Front axle - Reduction gear box (3 places)
2. Reduction gear box - Rear axle (2 places)

At the same time check retaining bolts for looseness.

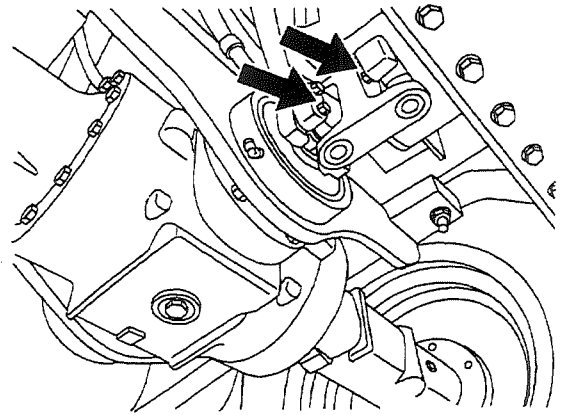
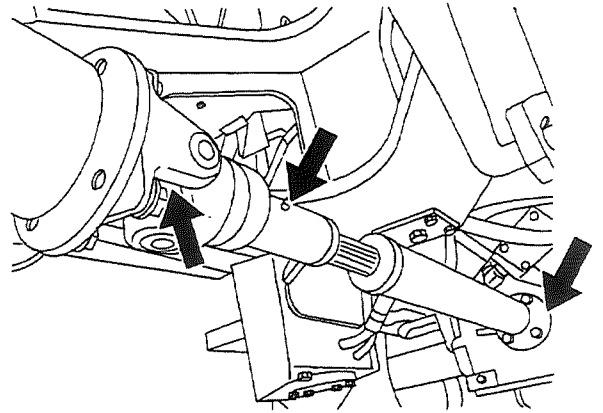

■ Check Injection Nozzle

WARNING
 DO NOT bring your hand close to tip of injection nozzle when using a nozzle tester. The high-pressure fuel oil spit out of injection nozzle may damage your skin. If the high-pressure fuel oil has touched your skin, consult a doctor within several hours.

Check the “static injection start pressure” and “condition of injection” using a nozzle tester.

When injection pressure of nozzle is too high or too low, or when condition of injection is poor, combustion in engine will become abnormal, causing drop in output or excessive emission of soot.

In such cases, “adjust the injection start pressure” or “change the nozzle”.

Contact with your authorized dealer for checking injection nozzle.

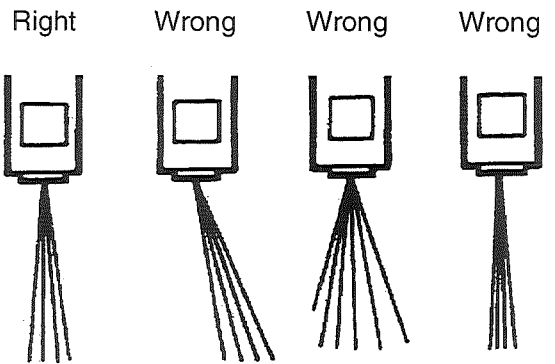

Periodic Maintenance/1000 Hours or 12 Months

At the same time carry out “Periodic Maintenance/100 Hours or 1 Month”, “Periodic Maintenance/250 Hours or 3 Months” and “Periodic Maintenance/500 Hours or 6 Months”.

■ Check Hydraulic Oil and Clean Strainer

WARNING

Oil is hot and tank is pressurized right after engine is stopped. Wait until oil cools before removing filler cap.

Remove it while releasing internal pressure.

Spilled oil will cause fire, so Wipe it off completely.

IMPORTANT

Hydraulic devices are precision machines. Contaminated hydraulic oil may cause an unexpected accident. Manage oil carefully.

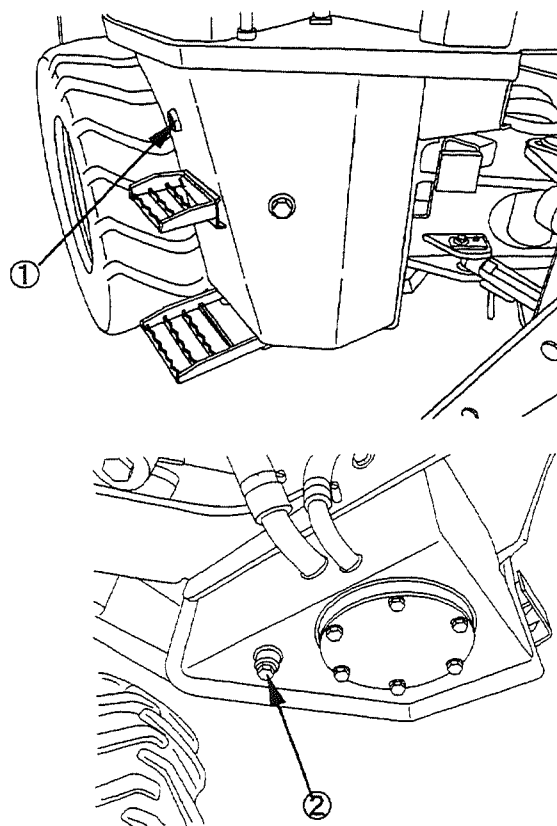

When replacing hydraulic oil, replace hydraulic return filter element and HST oil filter element at the same time.

1. Stop machine on a level ground, put the bucket on ground, apply parking brake and stop engine.
2. Move hydraulic control lever several times to relieve hydraulic pressure.
3. Remove oil filler port plug ① (open end wrench size : 32mm) slowly to relieve pressure.
4. Place a container under drain plug ② to receive drained oil.

Model	Capacity of hydraulic oil tank (Total) L [gal]
L3-2	25 [6.6]
L4-2	42 [11.1]
L5-2	42 [11.1]
L6-2	42 [11.1]

5. Remove drain plug ② (wrench size: 19mm) to drain oil.
6. After draining, remove cover ③ and then remove tank strainer ④ (open end wrench size: 41mm).
7. Remove dust from tank strainer ④ and clean it with unflammable washing oil. If strainer ④ is damaged, replace it with a new one.
8. Check tank inside for foreign substance and clean inside with washing oil.
9. Check O-ring of cover ③. Replace O-ring, if it is damaged.
Clean drain plug ②, then apply sealing tape around.
10. Install cleaned strainer ④ and tighten drain plug ②.

Next, replace hydraulic return filter element and HST oil filter element.

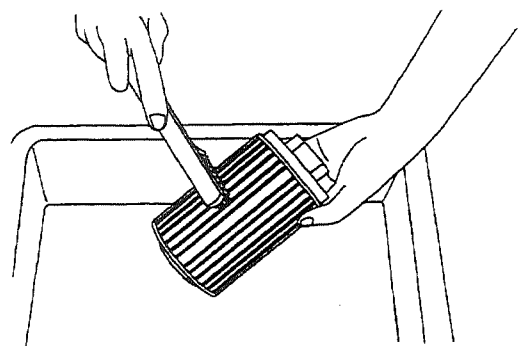
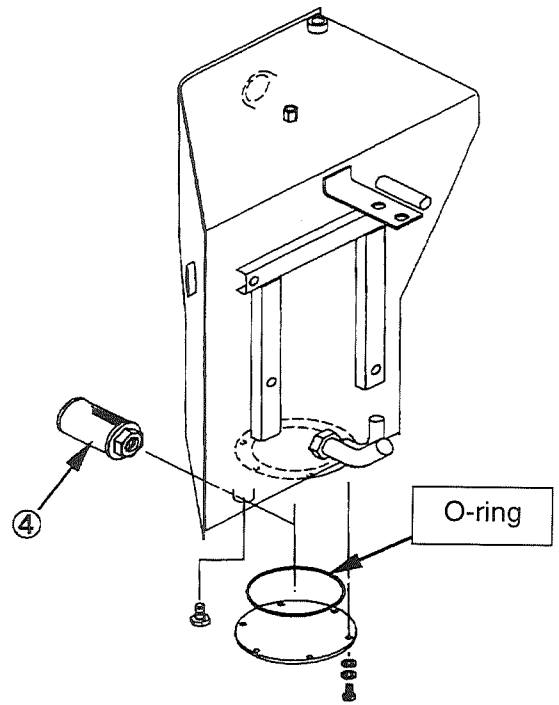
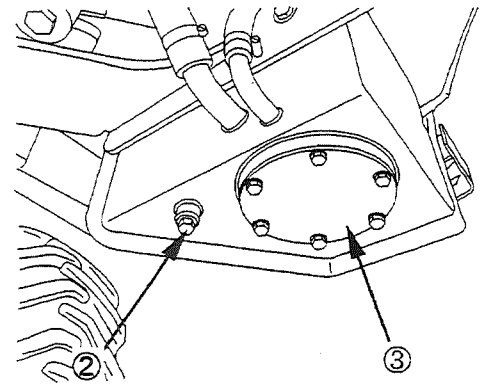

■ Replace Hydraulic Return Filter Element

WARNING

Oil is hot and tank is pressurized right after engine is stopped. Wait until oil cools before replacing hydraulic return filter. Spilled oil will cause fire, so wipe it off completely.

IMPORTANT

DO NOT reuse hydraulic return filter.

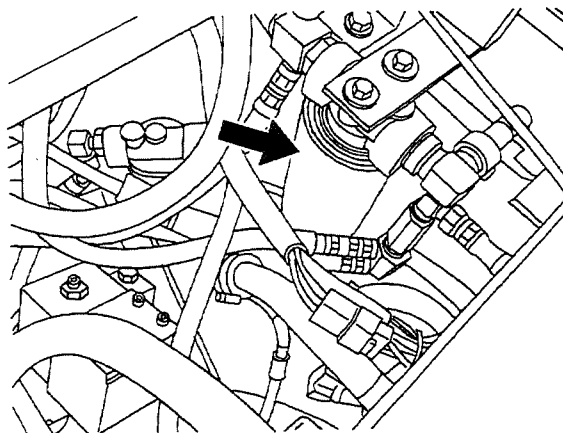

Remove floor plate. You will find hydraulic return filter at right of machine.

When replacing hydraulic oil, replace hydraulic return filter element at the same time.

1. Place container under hydraulic return filter to receive drained oil.
2. Turn hydraulic return filter counterclockwise (as viewed from bottom) to remove it.
3. Apply oil thinly to packing surface of a new hydraulic return filter.
4. Clean filter mounting and mount new hydraulic return filter by turning it clockwise. When the surface of packing is in contact with seal surface of filter mounting, tighten hydraulic return filter by 2/3 turns. If tightened excessively, packing is damaged to cause oil leakage. Be careful not to tighten hydraulic return filter excessively.

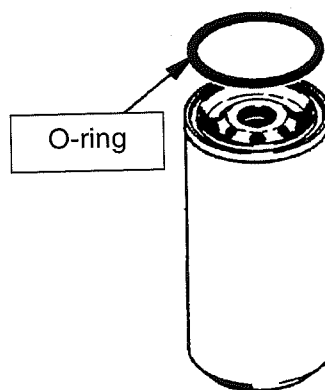

Replace hydraulic return filter after initial 100 hours (1 month) operation. Thereafter, replace it every 1000 hours (12 months) or when replacing the hydraulic oil.

Replace HST Oil Filter Element

WARNING
 Oil is hot and right after engine is stopped. Wait until oil before replacing HST oil filter element.
 Spilled oil will cause fire, so wipe it off completely.

IMPORTANT
 When supplying hydraulic oil, be careful to prevent dust from entering.
DO NOT reuse HST oil filter element.

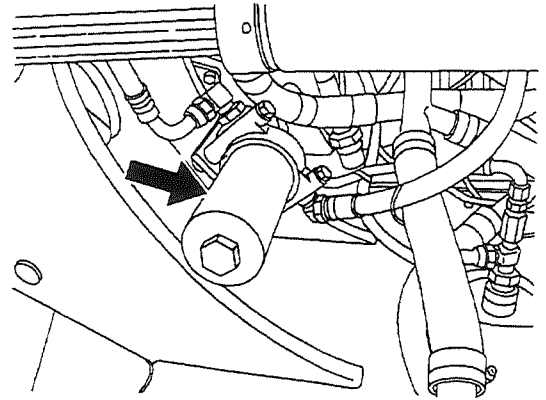

HST oil filter is located at right of rear frame center pin as viewed from bottom.

When replacing hydraulic oil, replace HST oil filter element.

1. Place a container under HST oil filter to receive drained oil.
2. Turn filter case counterclockwise (as viewed from bottom) to remove it. Replace O-ring of filter mounting with a new one.
3. Clean filter mounting and inside of filter case.
4. Install a new element to filter mounting and turn filter case clockwise to install it.
5. Supply the specified hydraulic oil as required through the oil filler port. (Refer to "Applicable Oil Lists".

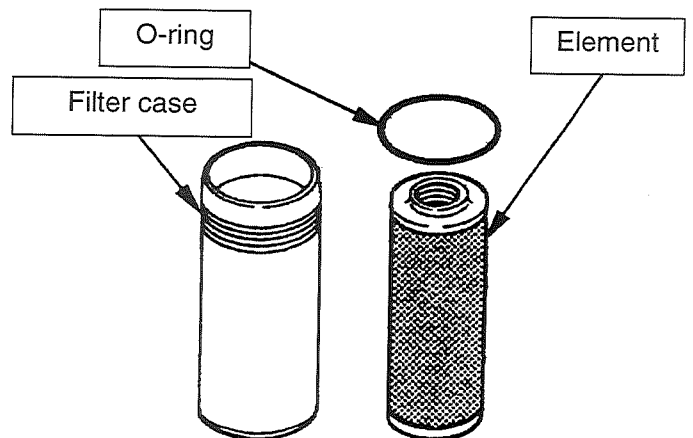

Model	Capacity of hydraulic oil tank (Total) L [gal]
L3-2	25 [6.6]
L4-2	42 [11.1]
L5-2	42 [11.1]
L6-2	

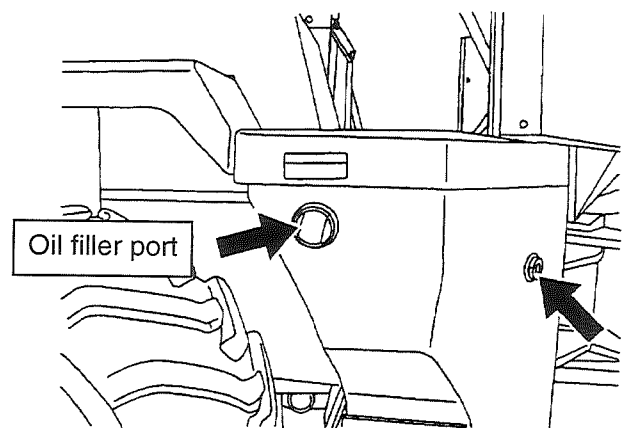

Periodic Maintenance/1000 Hours or 12 Months

6. Check O-ring of oil filler port plug. If it is damaged, replace it with a new one.
7. Install oil filler port plug. Then, bleed air from hydraulic system.
8. Run engine at low idle and push and pull each cylinder 4 or 5 times so that it will not reach stroke end [approx. 10cm (3.9in) before stroke end].

IMPORTANT

If engine runs at high idle with a cylinder at stroke end, air may in cylinders damage seals.

9. Then, move each cylinder to stroke end 3 - 4 times.
10. Lower bucket horizontally to ground, stop engine, check oil level gauge on side of tank, and add oil as necessary. Optimal oil level is somewhere between high and low levels.

Replace HST oil filter after initial 100 hours (1 month) operation. Thereafter, replace it every 1000 hours (12 months) or when replacing hydraulic oil.

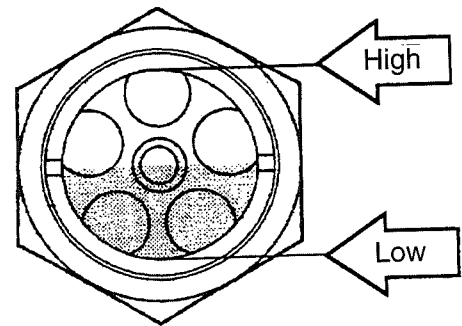
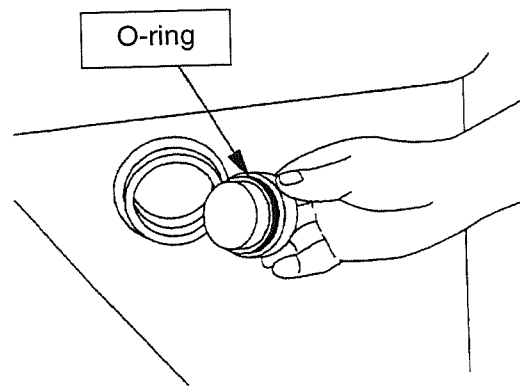

Change Axle Oil

WARNING

- Oil is hot right after operation. Wait until oil is cooled down before changing it.

- Front axle
If oil can be changed only when lift arm and bucket are lifted, lock working equipment control lever and safety bar, stop engine and apply chocks against tires. Moreover, use a support stand, to prevent working equipment from lowering.
- Rear axle
When tires removed and then oil is changed, axle height must be same at right and left horizontally. Use a support stand, etc. to make a stable condition.

1. Place a container under the drain plug ① to receive drained oil.
2. Remove dipstick/fill plug ② and then remove drain plug ①.
3. After draining, clean drain plug ①, Apply seal tape around plug and tighten it.

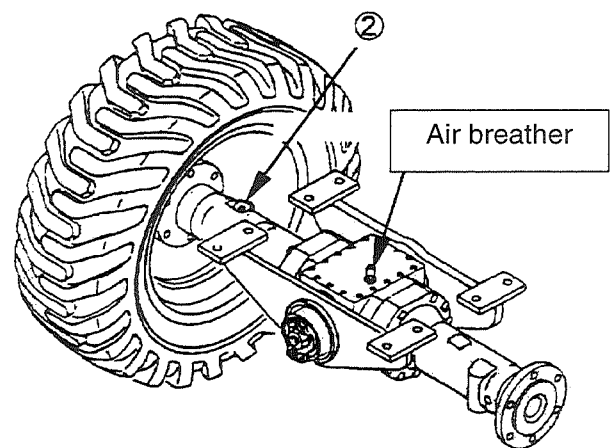
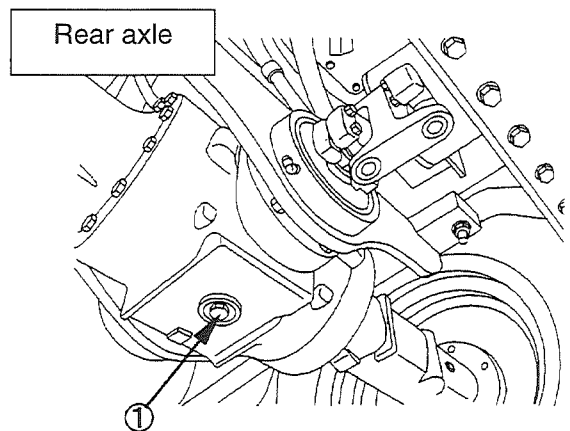
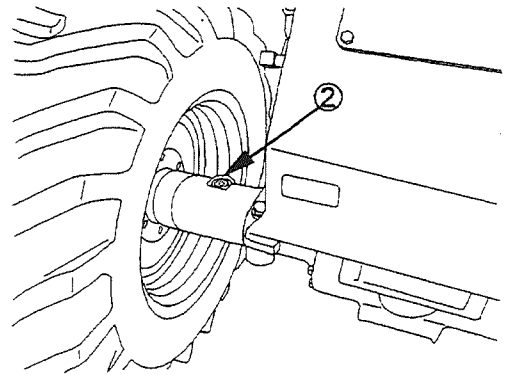
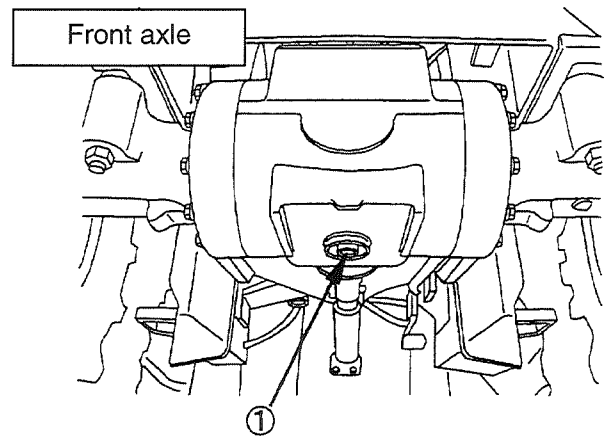

Periodic Maintenance/1000 Hours or 12 Months

4. Supply oil as required through oil filler port. Put dipstick/fill plug at oil filler port to If oil adheres up to inscribed line of dipstick, oil level is proper.

NOTE

If dipstick/fill plug is installed completely, an incorrect oil level reading can occur.

Model	Required oil q'ty L (gal)	
	Front axle	Rear axle
L3-2	3.5 (0.9)	←
L4-2	4.5 (1.2)	←
L5-2	4.5 (1.2)	←
L6-2		

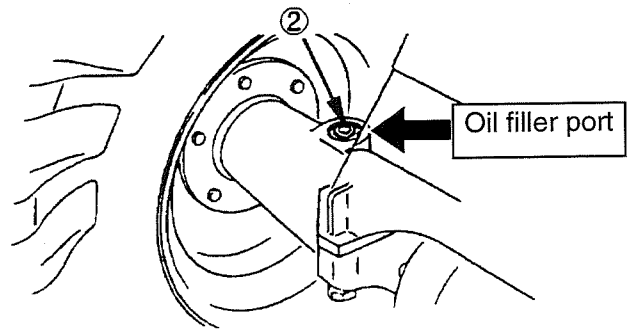

5. Clean dipstick/fill plug ② and apply seal tape around it. And then tighten it.

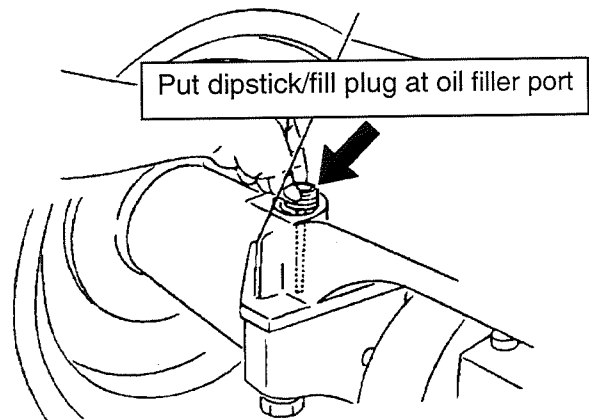

Replace the axle oil after initial 250 hours (3 months) operation. Thereafter, replace it every 1000 hours (12 months).

NOTE

If dipstick/fill plug is installed completely, an incorrect oil level reading can occur.

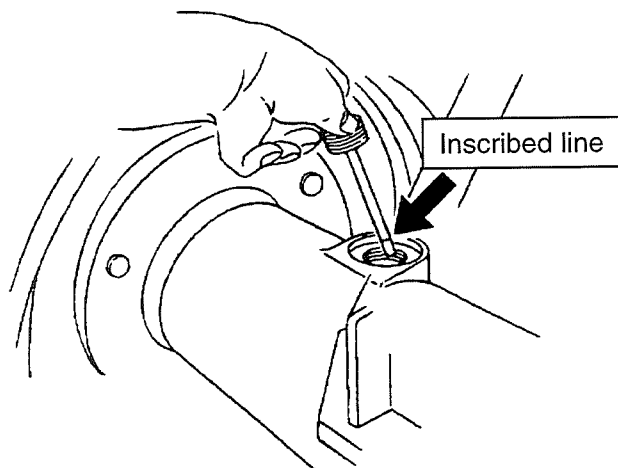

Change Reduction Gear Box Oil

WARNING

Oil is hot right after engine is stopped. Wait until oil cools before changing oil.

Spilled oil will cause fire, wipe it off completely.

1. Place a container under drain plug to receive drained oil.
2. Remove level plug ① and then remove the drain plug ② to drain oil.
3. After draining, clean drain plug ②, apply seal tape around it and tighten it.
4. Remove oil filler port plug ③ and supply gear oil as required. Supply oil until oil comes out from level port a little.

Model	Required oil q'ty L (gal)
L3-2	1.8 (0.5)
L4-2	1.8 (0.5)
L5-2	1.8 (0.5)
L6-2	1.8 (0.5)

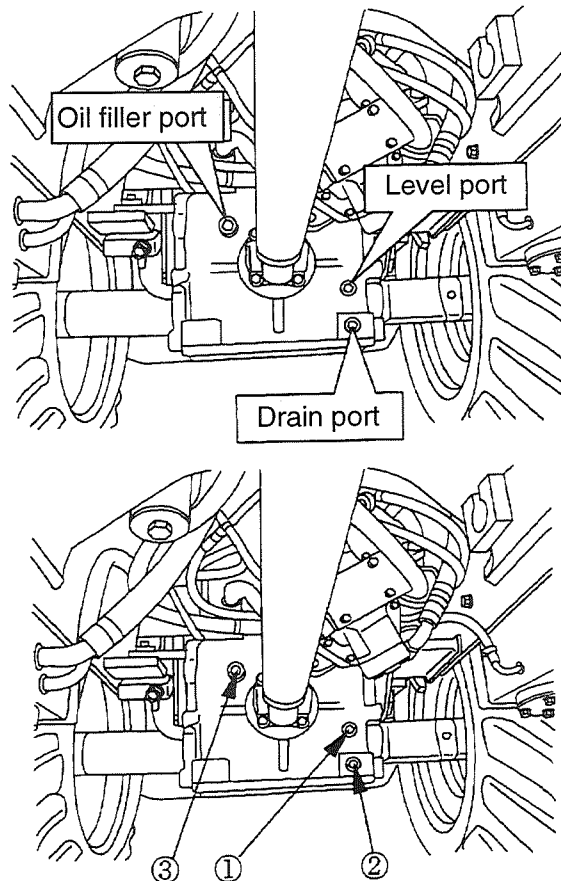

5. Clean level plug ① and the oil filler port plug, ③ apply seal tape around them and tighten them.
6. After supplying oil, start engine and move machine slowly to circulate oil.
7. Stop engine and check oil level of reduction gear again. If necessary, add specified oil as required. (Refer to above "4".)

Replace the oil in reduction gear after initial 250 hours (3 months) operation. Thereafter, replace it every 1000 hours (12 months).

■ Changing Brake Oil

WARNING

Stop machine on a level, solid ground, lower bucket to ground, apply parking brake and apply chocks to tires to prevent machine from moving.

Wear protective glasses to prevent oil from injuring your eyes.

A built-in wet brake is used. Use the specified oil (Torque converter oil, SAE5W). If you use automotive brake fluid (vegetable oil), brake may malfunction.

When changing brake oil, bleed air.

IMPORTANT

Contact with your authorized dealer for changing brake oil.

1. Insert one end of transparent vinyl tube into bleed screw, and put other end in a clean container so that brake oil will not be scattered.
2. Loosen the bleed screw discharge old brake oil. Discharge old brake oil while supplying new oil in order to prevent entry of air into empty brake oil tank. When clean oil begins to flow out, tighten the bleed screw.

NOTE

Two people are required to bleed brake system, one to depress brake pedal and other to open and close bleed screw.

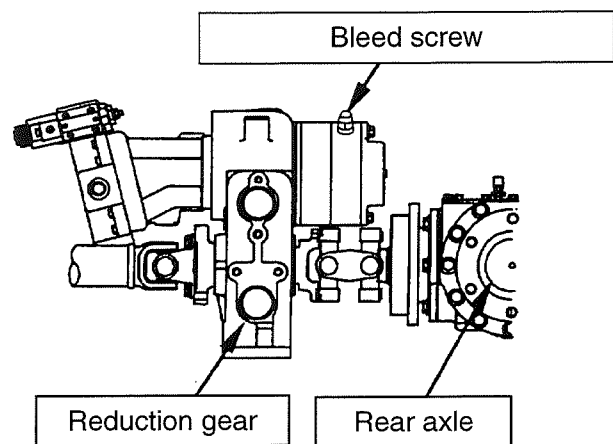
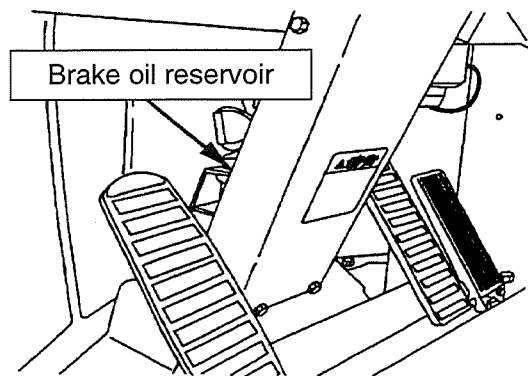

■ Bleeding Procedure of Brake System

WARNING

Carefully confirm type of oil. Wrong type of oil will cause malfunction of brake. (Refer to "Applicable Oil Lists" on P.3-13.)

IMPORTANT

Two people are required to bleed brake system one to depress brake pedal and other to open and close bleed screw.

Make sure that more than half of brake oil reservoir tank is filled with oil while oil bleeding.

1. Insert one end of transparent vinyl tube into bleed screw, and put other end in a clean container so that brake oil will not be scattered.
2. Depress brake pedal several times, and while depressing on it completely, loosen bleed screw by turning 1/2-1 turn in order to discharge oil.
3. Tighten the bleed screw and pedal.
4. Repeat above operations 2 and 3 until clean oil begins to flow through vinyl tube and air bubbles are removed completely.
5. When air in tube is completely removed, tighten bleed screw while depressing pedal.
6. After air bleeding, add brake oil to reservoir tank up to appropriate level.

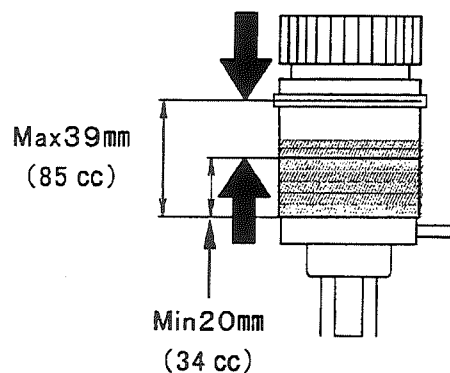
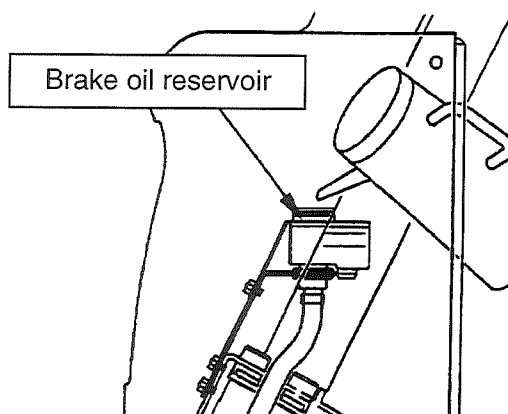
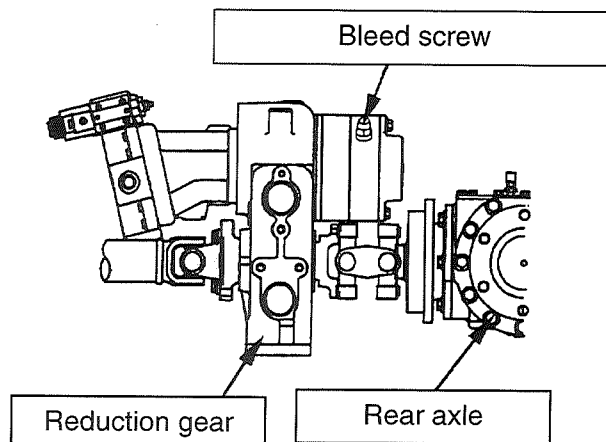
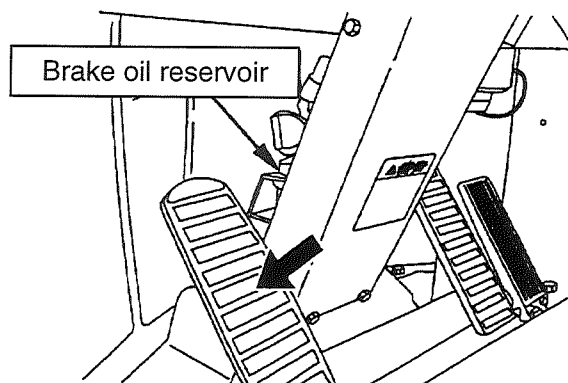

■ Replace Air Cleaner Element



WARNING

Stop engine before servicing the air cleaner.

IMPORTANT

If machine is to be operated in dusty places, shorten service interval.

Clean and check...Element every 250 hours (3 months) of operation or if air cleaner dust indicator comes on.

Replace.....Replace element with new one when outer element is cleaned 6 times or after 1000 hours (12 months) of operation.

1. Replace clamps and remove dust cup.
2. Take out element and replace it with a new one.
3. Install cleaned dust cup and fix it with clamps securely.
4. Check air piping for looseness of hose clamps.

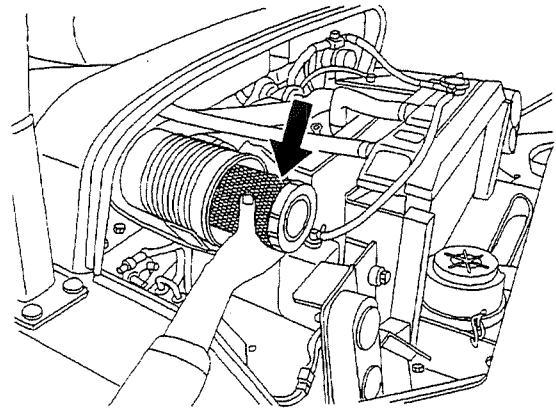
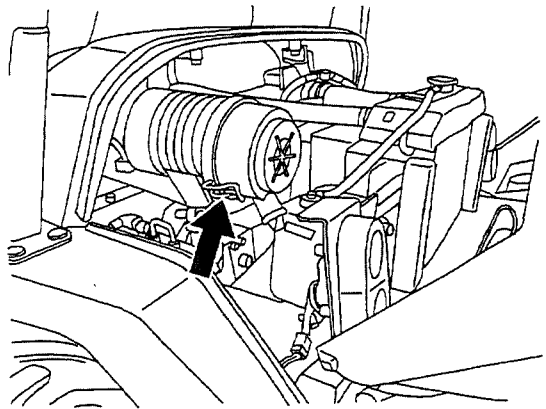

Maintenance/When Required

■ Check Axle Oil Level



WARNING

Oil is hot right after operation. Wait until oil is cooled down before checking. Spilled oil may cause fire. Wipe it off completely.

If oil leakage visible, check oil level.

Check oil level on a ground where the machine is horizontal. If machine is inclined to left or right, an incorrect oil level reading can occur.

1. Remove dipstick/fill plug and check to see if oil reaches inscribed line on dipstick.
2. If oil level is insufficient, add oil as required. Put dipstick/fill plug at oil filter port to check oil level. If oil adheres up to inscribed line of dipstick, oil level is proper. Refer to **“Replace Axle Oil”** and **“Applicable Oil Lists”**
3. Clean dipstick/fill plug ② and apply seal tape around it. And then tighten it.

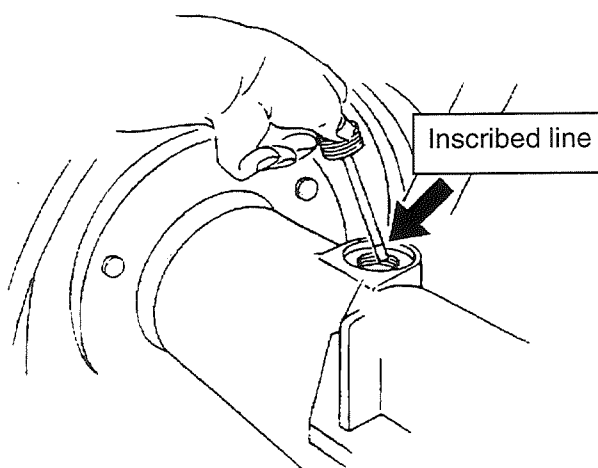
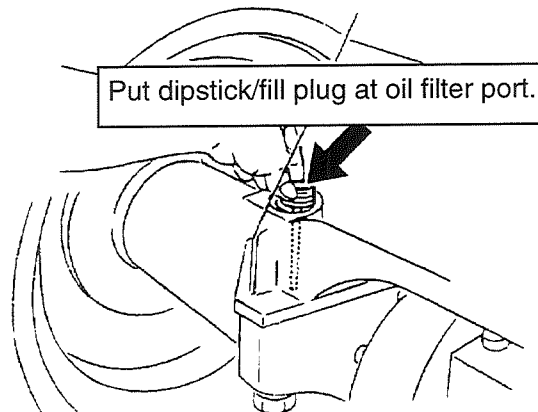
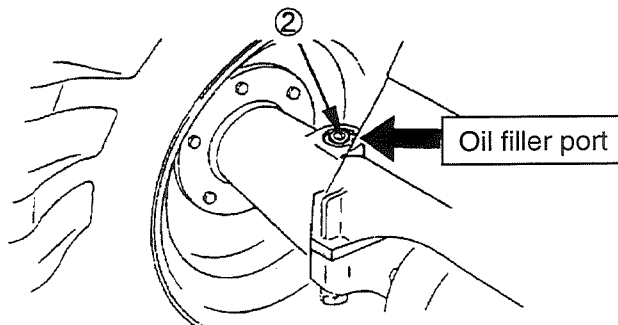

■ Clean and Check Radiator Fin

 **CAUTION**

When cleaning with compressed air, wear protective glasses. Use the compressed air of 200Kpa (30 PSI) or less.

Clogging of radiator fins with dirt, leaves of trees, or other foreign substances causes overheating, because stream of cooling air is obstructed and thus cooling efficiency of radiator significantly decreases. If clogging is found, then clean it with water or compressed air. If cleaning is done with water, protect alternator from water splashes.

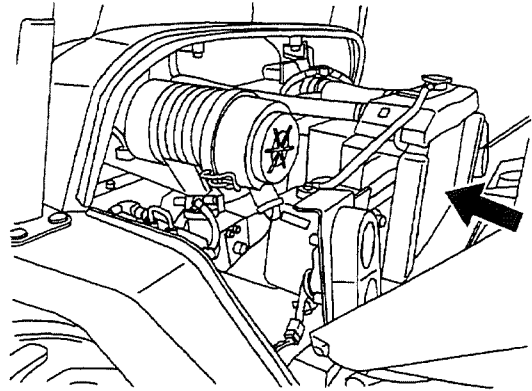

Change Coolant and Clean Cooling System

WARNING

If engine is hot and radiator cap is removed, steam or hot water is spouted to burn you. Before servicing cooling system, stop engine and make sure that coolant is cooled and radiator cap can be removed by hand. To remove radiator cap, turn it slowly counterclockwise as relieving internal pressure.

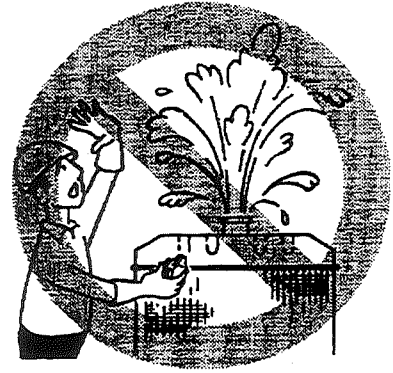

For the method to replace coolant, refer to "Fuel, Water, and Lubricants, Selection and Capacities". When changing coolant, clean inside of cooling system. Water scale or rust inside cooling system will reduce cooling capacity, causing overheating.

IMPORTANT

- Check rubber hose. If it is damaged, replace it with a new one. Also check hose clamps for looseness.
- Check radiator fins for clogging with dust and insects. If clogging is found, clean fins with water or compressed air.

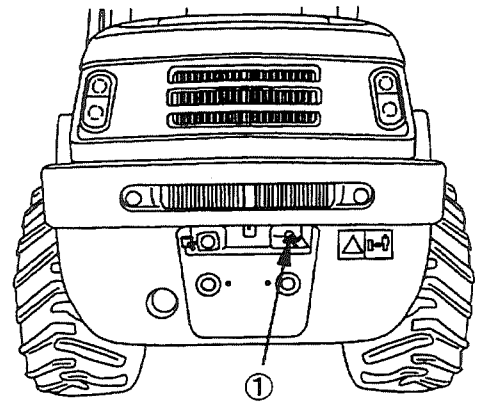

L3-2

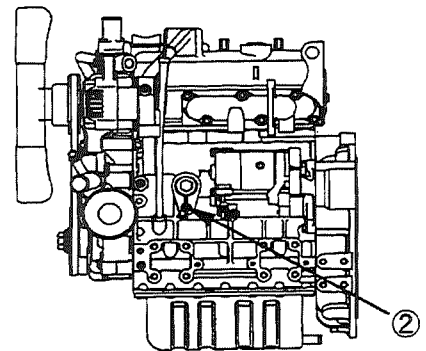

1. Stop machine on a level ground and stop engine to cool cooling system. Place a container under drain cock ① to receive drained coolant.
2. Open engine hood. Slowly turn radiator cap counterclockwise as relieving internal pressure to remove it.
3. Loosen drain cock ① of radiator to drain coolant.
4. Loosen drain cock ② of engine crankcase to drain coolant from engine block. (In L5-2/L6-2, remove the hose to drain coolant.)
5. Close the drain cocks ① and ②.

L4-2

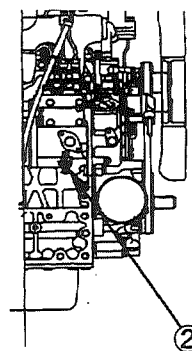

L5-2/L6-2

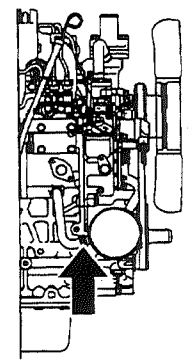

Maintenance/When Required

6. Clean radiator using a commercially available cleaning agent. Follow written instructions of manufacturer of cleaning agent. (Run the engine at speed slightly higher than idling speed and, when coolant temperature has reached 80°C or more, keep running for about 30 minutes. If temperature is low, cleaning effect is not as expected because thermostat is closed.)

NOTE

Control water supply during cleaning so that cooling system will be full of water.

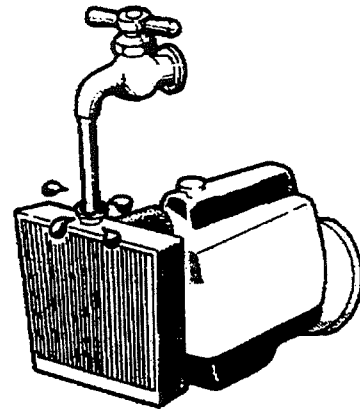

7. After cleaning, drain entire cleaning agent and then fill radiator with tap water. Start engine and keep it running for about 10 minutes, and drain water. Repeat this water-washing until clean water flows out.

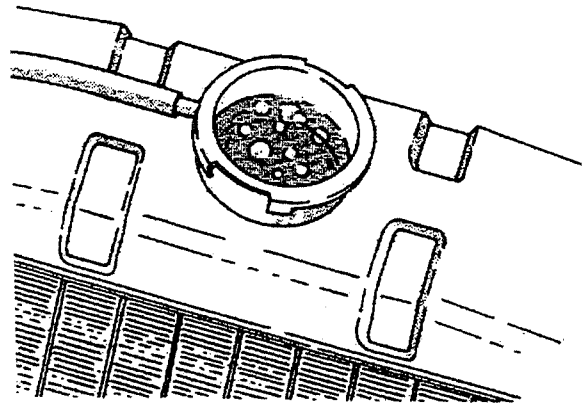

8. Prepare coolant that consists of tap water and rust-preventive agent or antifreeze. Slowly feed this coolant into radiator. Run engine without radiator cap to bleed air of cooling system completely. Refer to "Coolant"

Model	Required coolant q'ty L (gal)
L3-2	5.5 (1.5)
L4-2	5.7 (1.5)
L5-2	6.1 (1.6)
L6-2	6.1 (1.6)

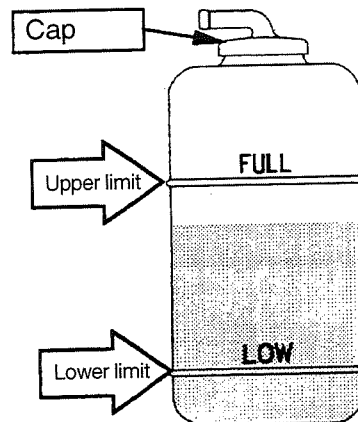

9. Stop engine and optimize the quantity of coolant. Feed coolant up to top of radiator's filler port and up to "FULL" of reservoir tank.

10. Check radiator cap. If packing is damaged or if spring is fatigued, replace cap with a new one.

11. Securely install cap.

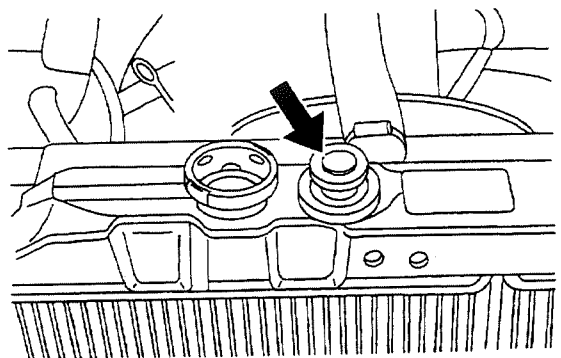

■ Clean Fuel Tank



WARNING

Fuel is flammable. When servicing fuel system, turn OFF starting switch key and keep open flames away from machine. Spilled fuel will cause fire, wipe it away completely.

If engine does not start smoothly or output is insufficient due to poor fuel supply, check and clean fuel tank.

1. Place a container under drain plug ① to receive drained fuel.
2. Remove drain plug ① and drain fuel.
3. Remove lower cover ②.
4. Clean inside of tank with non-flammable solvent and remove dust accumulated in bottom of tank.
5. Apply seal tape around drain plug ① and tighten it.
6. Install the cover ② and supply fuel. Replace O-ring of cover ②, if it is damaged.
7. Bleed fuel system of air and make sure that fuel does not leak. Refer to "Bleed air from fuel system".

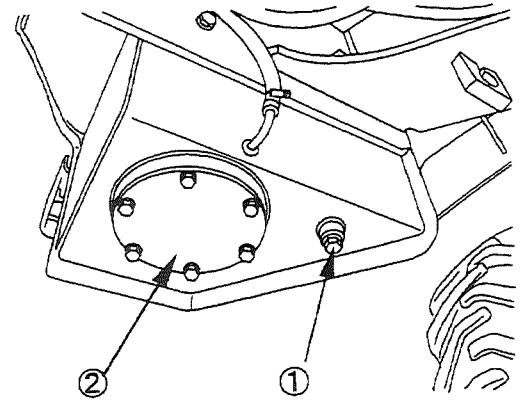

WARNING

Before starting engine, make sure of safety around engine and then crank up.

IMPORTANT

Shortage of fuel and suction of air will make the electric fuel pump empty, causing a loud suction sound (operating sound). Turn OFF the starter switch to avoid the empty pump.

Maintenance/When Required

■ Clean Engine Breather Element

IMPORTANT
Before removing breather, wipe away dust around it.

Remove breather and clean element with non-flammable solvent.

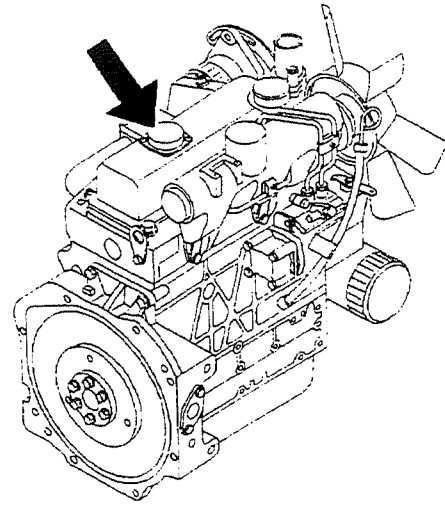

■ Check and Adjust Engine Valve Clearance

Contact your authorized dealer for check and adjustment of valve and clearance.

■ Replace Fuses

WARNING

Before replacing fuses, be sure to turn off power (starter switch OFF). Before replacing hazard fuse, disconnect negative terminal of battery.

DO NOT use a fuse exceeding specified capacity, and wire, silver paper or any other materials, otherwise electric wire will be overheated and burned.

If a new fuse blows out right after replacement, there are other problems. Contact with your authorized dealer.

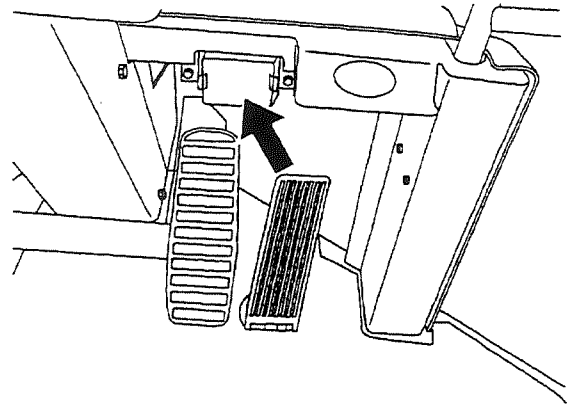

1. Set starter switch key to "OFF" and remove key.
2. Remove fuse cover.
3. Check position and capacity of fuse according to trouble situation. Refer to "Fuse Capacity and Circuit Name".
4. Remove fuse. If fuse has blown out, replace it with a new one of specified capacity.
5. Insert fuse completely.

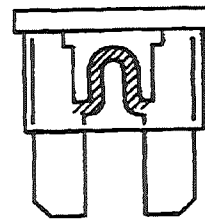

(Right)

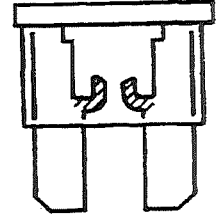

(Fuse has blown out.)

■ Replace Slow Blow Fuse

 **WARNING**

Before replacing the slow blow fuse, turn off power (set the starter switch to "OFF"). Also disconnect negative terminal of battery. If a new slow blow fuse blows out right after replacement, there are other problems. Contact with your authorized dealer.

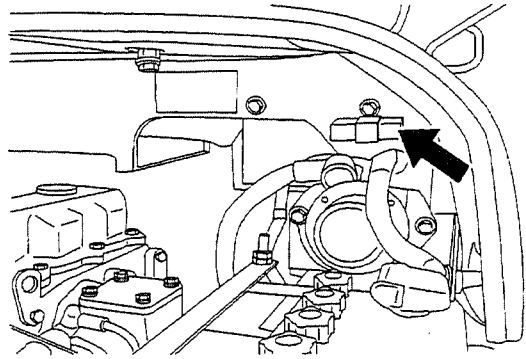

1. Set starter switch key to "OFF" and remove key.
2. Open engine hood.
3. Remove slow blow fuse. If it has blown out, replace it with a new one.
5. Insert slow blow fuse completely.

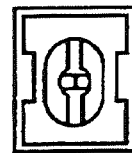

(Right)

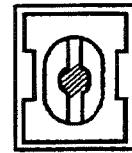

(Fuse has blown out.)

■ Replace Cutting Edge

 **WARNING**

Stop machine on a level ground, stop engine and lock working equipment control lever with safety lock.
Before replacing cutting edge, set blocks to prevent bucket from lowering.

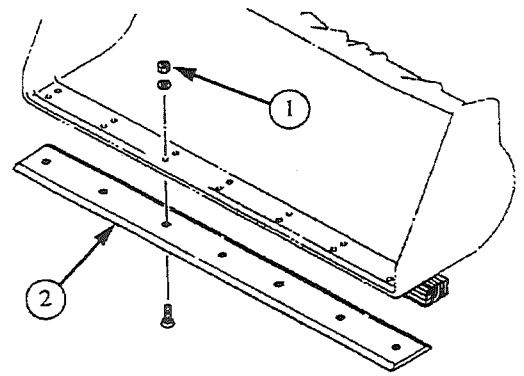

1. Raise bucket so that its bottom will be horizontal, and place blocks under bucket. Stop engine.
2. Remove bolts and nuts ① and then remove cutting edge ②.
3. If only one side of cutting edge is worn out, reverse cutting edge for reuse. If both sides have become worn out, replace cutting edge with a new one.
4. Clean mounting surface and mount cutting edge.

Model	Nut tightening torque N·m (ft·lb)
L3-2	186.2 - 235.2 (137-174)
L4-2	186.2 - 235.2 (137-174)
L5-2	186.2 - 235.2 (137-174)
L6-2	

5. Start engine, raise bucket slowly and remove blocks.
6. After operation of several hours, retighten mounting nuts.

Adjustment of Each Part

Adjust Auto Leveler



WARNING

Stop machine on a level ground and apply chocks to the front and rear of tires. Apply parking brake and fix front and rear frames with safety bar. While arm is being lifted, don't go to under working device.

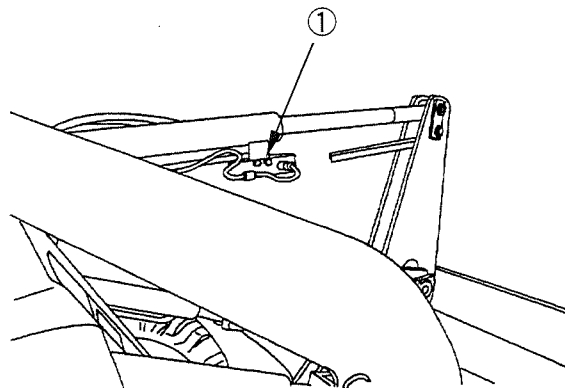

1. Lower bucket close to ground, and stop engine in accordance with desired angle of excavation.
2. Loosen bolt ①, and move bracket ④ so that edge of bracket ② will be approx. 30~35mm (1.2 - 1.4in) away from center of sensitive surface of proximity switch ③. Then secure bracket ②.
3. Loosen two nuts ⑤ to adjust clearance between surface of proximity switch ③ and bracket ②. Distance must be 5-7mm (0.2-0.3in).
4. After adjustment, start engine and check adjustment. Raise lift arm, dump bucket, raise engine speed to maximum, set hydraulic control lever in "tilt back" position, and release your hold on lever.
5. When bucket angle is adjusted correctly, check that hydraulic control lever automatically returns to neutral position.
6. Lower lift arm, and check that bucket is set at desired angle.

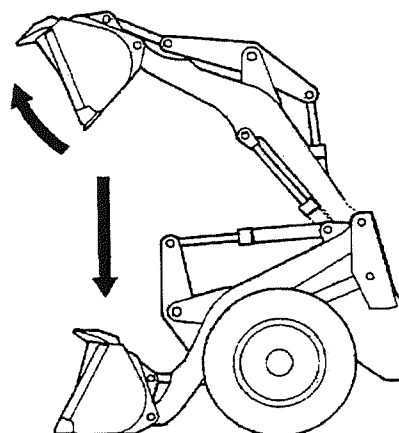
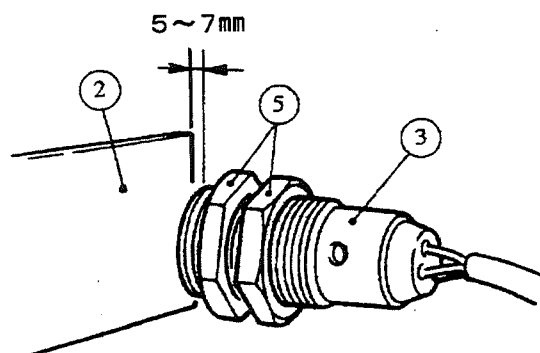
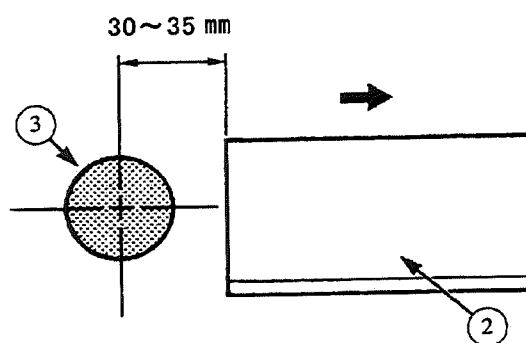

■ How to Release Parking Brake Manually

WARNING
 Each section is hot right after engine has stopped. Wait until each section is cooled down.

Parking brake is released by oil pressure. When engine stops, parking brake is not released even if its switch is set to "OFF".

When engine does not start and machine must be towed, release parking brake forcedly (manually).

1. Remove bolt ① (bolt for releasing, M10×L55).
2. Remove plug ②.
3. Tighten the bolt ① into the port B from which the plug ② was removed.

Parking brake piston is pulled back to release parking brake and so you can move machine very slowly.

4. After work, remove bolt ① from port B. Apply seal tape around plug ② and tighten it into port B.
5. Set bolt ① to its original position.

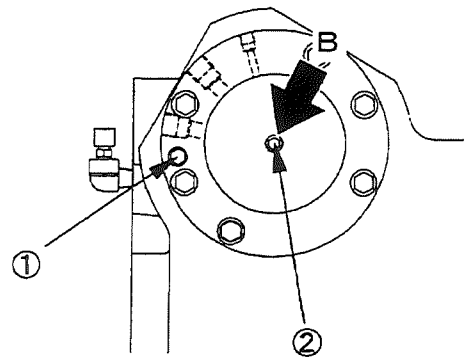
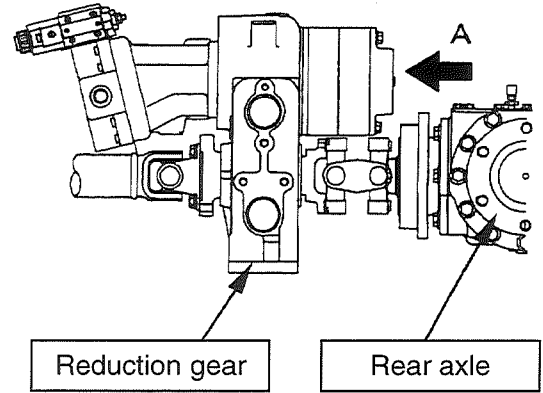

VIEW A

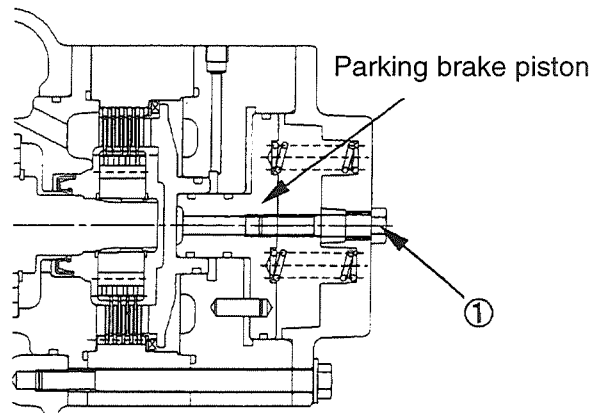

Troubleshooting

Failure may occur due to combination of various causes, and if any failure occurs, cause should be investigated for each item and remedial steps should be taken.

If it seems that there are troubles or causes other than the following items, ask your authorized dealer for inspection. For items marked with ☉, ask your authorized dealer for inspection.

Symptom	Cause	Remedy
■ Engine		
Engine does not start when starter is turned.	<input type="radio"/> Fuel shortage	<input type="radio"/> Supply fuel.
	<input type="radio"/> Air is mixed in fuel system.	<input type="radio"/> Bleed air.
	<input type="radio"/> Fuel injection pump or nozzle is faulty.	☉ Adjust or replace.
	<input type="radio"/> Clogging of fuel system	<input type="radio"/> Replace fuel filter element or clean strainer.
	<input type="radio"/> Insufficient intake air quantity	<input type="radio"/> Clean or replace air cleaner element.
	<input type="radio"/> Insufficient compression pressure	☉ Repair or replace cylinder, piston ring, etc.
Starter does not turn.	<input type="radio"/> Battery is not charged enough.	<input type="radio"/> Charge.
	<input type="radio"/> Malfunction of starter or starter relay	☉ Repair or replace.
	<input type="radio"/> Shift lever is not in neutral position.	<input type="radio"/> Set shift lever in neutral position.
Engine exhaust color is white or blue.	<input type="radio"/> Excessive quantity of oil in oil pan	<input type="radio"/> Adjust it to specified oil quantity.
	<input type="radio"/> Improper fuel	<input type="radio"/> Change it with specified fuel.
	<input type="radio"/> Insufficient compression pressure	☉ Repair or replace cylinder, piston ring, etc.
Engine exhaust color is black or dark gray.	<input type="radio"/> Improper fuel	<input type="radio"/> Change it with specified fuel.
	<input type="radio"/> Improper valve clearance	☉ Adjust clearance.
	<input type="radio"/> Insufficient intake air quantity	<input type="radio"/> Clean or replace air cleaner element.
Water temperature is too high.	<input type="radio"/> Insufficient quantity of coolant	<input type="radio"/> Supply coolant.
	<input type="radio"/> Loosened fan belt	<input type="radio"/> Adjust tension.
	<input type="radio"/> Loosened radiator cap	<input type="radio"/> Tighten cap.
	<input type="radio"/> Dust and fur accumulated in cooling system	<input type="radio"/> Supply coolant or clean inside of cooling system.
	<input type="radio"/> Faulty thermostat	☉ Replace thermostat.
	<input type="radio"/> Radiator fins are clogged.	<input type="radio"/> Clean fins.
Engine oil pressure indicator light comes on.	<input type="radio"/> Insufficient oil quantity in oil pan	<input type="radio"/> Supply to specified oil quantity.
	<input type="radio"/> Oil filter element is clogged.	<input type="radio"/> Replace oil element.
	<input type="radio"/> Oil leakage from pipe or joint	☉ Check/repair.
	<input type="radio"/> Faulty monitor	☉ Replace monitor.
■ HST (Transmission)		
Reduction in traveling speed and difficulty in traveling	<input type="radio"/> Insufficient oil in reduction gear box	<input type="radio"/> Supply to specified oil quantity.
	<input type="radio"/> Imperfect shift lever	<input type="radio"/> Completely shift lever.
	<input type="radio"/> Abrasion or damage to parts in gear box	☉ Repair or replace.

Symptom	Cause	Remedy
Excessive rise of oil temperature	<input type="radio"/> Insufficient or excessive oil	<input type="radio"/> Fill up to specified level.
	<input type="radio"/> Engine is overheated.	<input type="radio"/> Inspect engine.
	<input type="radio"/> Deterioration or poor quality of oil	<input type="radio"/> Replace oil.
	<input type="radio"/> Suction strainer is clogged.	<input type="radio"/> Clean or replace.
	<input type="radio"/> Improper speed gear	<input type="radio"/> Use correct speed gear.
Noise	<input type="radio"/> Suction strainer is clogged.	<input type="radio"/> Clean or replace.
	<input type="radio"/> Abrasion or damage to parts in gear box	<input checked="" type="radio"/> Repair or replace.
■ Propeller Shaft		
Noise	<input type="radio"/> Spline is worn.	<input checked="" type="radio"/> Replace.
	<input type="radio"/> Universal joint is worn or damaged.	<input checked="" type="radio"/> Replace.
	<input type="radio"/> Bearing is worn or damaged.	<input checked="" type="radio"/> Replace.
	<input type="radio"/> Each section is loosened.	<input type="radio"/> Retighten.
	<input type="radio"/> Insufficient lubrication	<input type="radio"/> Lubricate.
■ Axle		
Noise	<input type="radio"/> Insufficient oil or poor quality	<input type="radio"/> Supply to specified oil quantity.
	<input type="radio"/> Gears are worn or damaged.	<input checked="" type="radio"/> Repair or replace.
	<input type="radio"/> Propeller shaft is bent.	<input checked="" type="radio"/> Repair or replace.
	<input type="radio"/> Bearings are worn or damaged.	<input checked="" type="radio"/> Repair or replace.
Power is not transmitted.	<input type="radio"/> Shaft is broken.	<input checked="" type="radio"/> Replace
	<input type="radio"/> Internal parts are worn or damaged.	<input checked="" type="radio"/> Repair or replace.
■ Steering		
Malfunction	<input type="radio"/> Insufficient oil quantity in oil tank	<input type="radio"/> Supply to specified oil quantity.
	<input type="radio"/> Main pump is faulty.	<input checked="" type="radio"/> Repair or replace.
	<input type="radio"/> Orbit roll or flow sensing valve is improper.	<input checked="" type="radio"/> Repair or replace.
	<input type="radio"/> Malfunction of steering cylinder	<input checked="" type="radio"/> Repair or replace.
■ Service Brake		
Braking force is lowered.	<input type="radio"/> Air is mixed in brake system.	<input type="radio"/> Bleed air.
	<input type="radio"/> Oil leakage from brake piping	<input checked="" type="radio"/> Repair and supply brake oil.
	<input type="radio"/> Malfunction of master cylinder	<input checked="" type="radio"/> Repair or replace.
	<input type="radio"/> Brake discs are worn.	<input checked="" type="radio"/> Replace.
Dragging	<input type="radio"/> Master cylinder is faulty.	<input checked="" type="radio"/> Repair or replace.
	<input type="radio"/> Brake piston is stuck.	<input checked="" type="radio"/> Repair.
Abnormal noise	<input type="radio"/> Deterioration of brake oil and reduction gear oil	<input type="radio"/> Change oil.
	<input type="radio"/> Improper oil	<input type="radio"/> Change it with specified oil.
■ Parking Brake		
Parking brake does not function.	<input type="radio"/> Brake plate and disc are worn.	<input checked="" type="radio"/> Repair or replace.

Troubleshooting

Symptom	Cause	Remedy
■ Hydraulic System		
Lift arm does not rise or rises slowly.	<input type="radio"/> Insufficient oil quantity in oil tank	<input type="radio"/> Supply to specified oil quantity.
	<input type="radio"/> Suction strainer is clogged.	<input type="radio"/> Clean or replace.
	<input type="radio"/> Control cable is faulty.	<input checked="" type="radio"/> Adjust or replace.
	<input type="radio"/> Main pump is faulty.	<input checked="" type="radio"/> Repair or replace.
	<input type="radio"/> Oil seal is damaged in cylinder.	<input checked="" type="radio"/> Replace.
Bucket swings while machine is traveling.	<input type="radio"/> Oil seal in cylinder is damaged.	<input checked="" type="radio"/> Replace.
	<input type="radio"/> Oil tightness of control valve is faulty.	<input checked="" type="radio"/> Adjust, repair or replace.
	<input type="radio"/> Pin and bush of linkage are worn.	<input checked="" type="radio"/> Replace.
Excessive rise of oil temperature	<input type="radio"/> Suction strainer is clogged.	<input type="radio"/> Clean or replace.
	<input type="radio"/> Tension of engine fan belt is insufficient.	<input type="radio"/> Adjust.
	<input type="radio"/> Insufficient or excessive oil	<input type="radio"/> Fill up to specified oil quantity.
	<input type="radio"/> Engine is overheated.	<input checked="" type="radio"/> Inspect engine.
	<input type="radio"/> Deterioration of oil or poor quality	<input type="radio"/> Replace oil.

■ Specifications

• L3-2

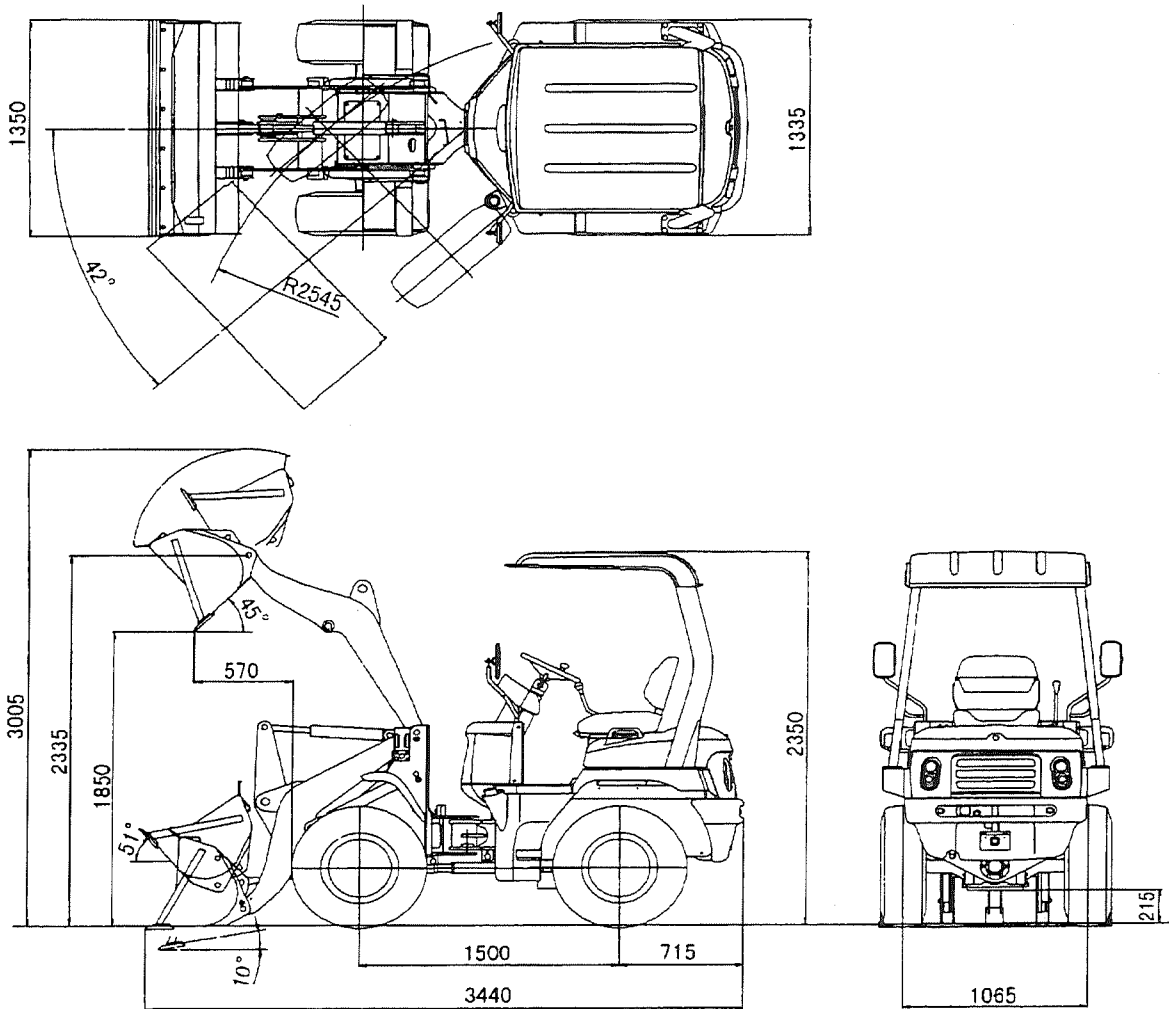

Bucket capacity (with BOC)		0.3m ³
Operating weight		1915kg
Engine	Maker/Model	KUBOTA D1105-K2A
	Flywheel power/Rated speed	16.2kW (22PS)/ 2500rpm
	Piston displacement	1,123 L
	Fuel tank capacity	33 L (Light oil)
	Operating load	500kg
Max. drawbar pull		17200N (1750kg)
Performance	Travel speed	1st gear F&R 6.2km/h
	(2 forward & 2 reverse)	2nd gear F&R 15km/h
	Gradeability	30°
	Turning radius (center of outside wheel)	2545mm
	Articulation angle	42°

Dimensions	Overall length (with BOC at ground)	3440mm
	Overall width (Bucket)	1350mm
	Overall height (Canopy)	2350mm
	Wheelbase	1500mm
	Ground clearance	215mm
	Dumping clearance (with BOC)	1850mm
	Dumping reach (with BOC)	570mm
	Bucket hinge pin height (Max.)	2335mm
Battery		12V-75D26
Transmission control HST		HST (Electrical)
Tire size/Pressure (standard)		10-16.5-4PR 200kPa

• L4-2

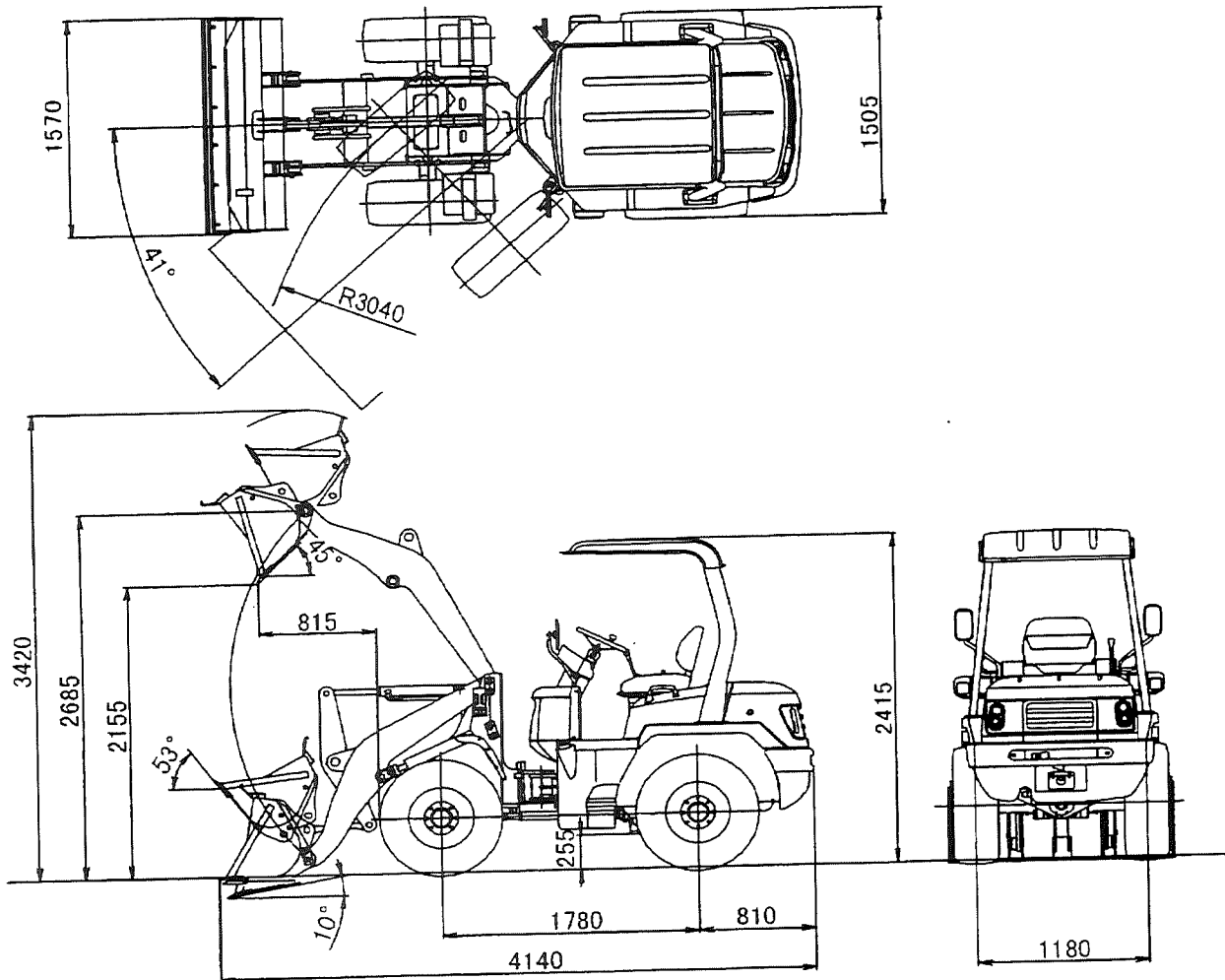

Bucket capacity (with BOC)		0.4m ³
Operating weight		2645kg
Engine	Maker/Model	KUBOTA D1503-DI-K2A
	Flywheel power/Rated speed	21.3kW (29PS)/ 2400rpm
	Piston displacement	1,499 L
	Fuel tank capacity	50 L (Light oil)
	Operating load	650kg
Max. drawbar pull		27000N (2750kg)
Performance	Travel speed	1st gear F&R 7.5km/h
	(2 forward & 2 reverse)	2nd gear F&R 15km/h
	Gradeability	30°
	Turning radius (center of outside wheel)	3040mm
	Articulation angle	41°

Dimensions	Overall length (with BOC at ground)	4140mm
	Overall width (Bucket)	1570mm
	Overall height (Canopy)	2415mm
	Wheelbase	1780mm
	Ground clearance	255mm
	Dumping clearance (with BOC)	2155mm
	Dumping reach (with BOC)	815mm
Bucket hinge pin height (Max.)		2685mm
Battery		12V-75D26
Transmission control HST		HST (Electrical)
Tire size/Pressure (standard)		12.5/70-16-6PR 200kPa

• L5-2

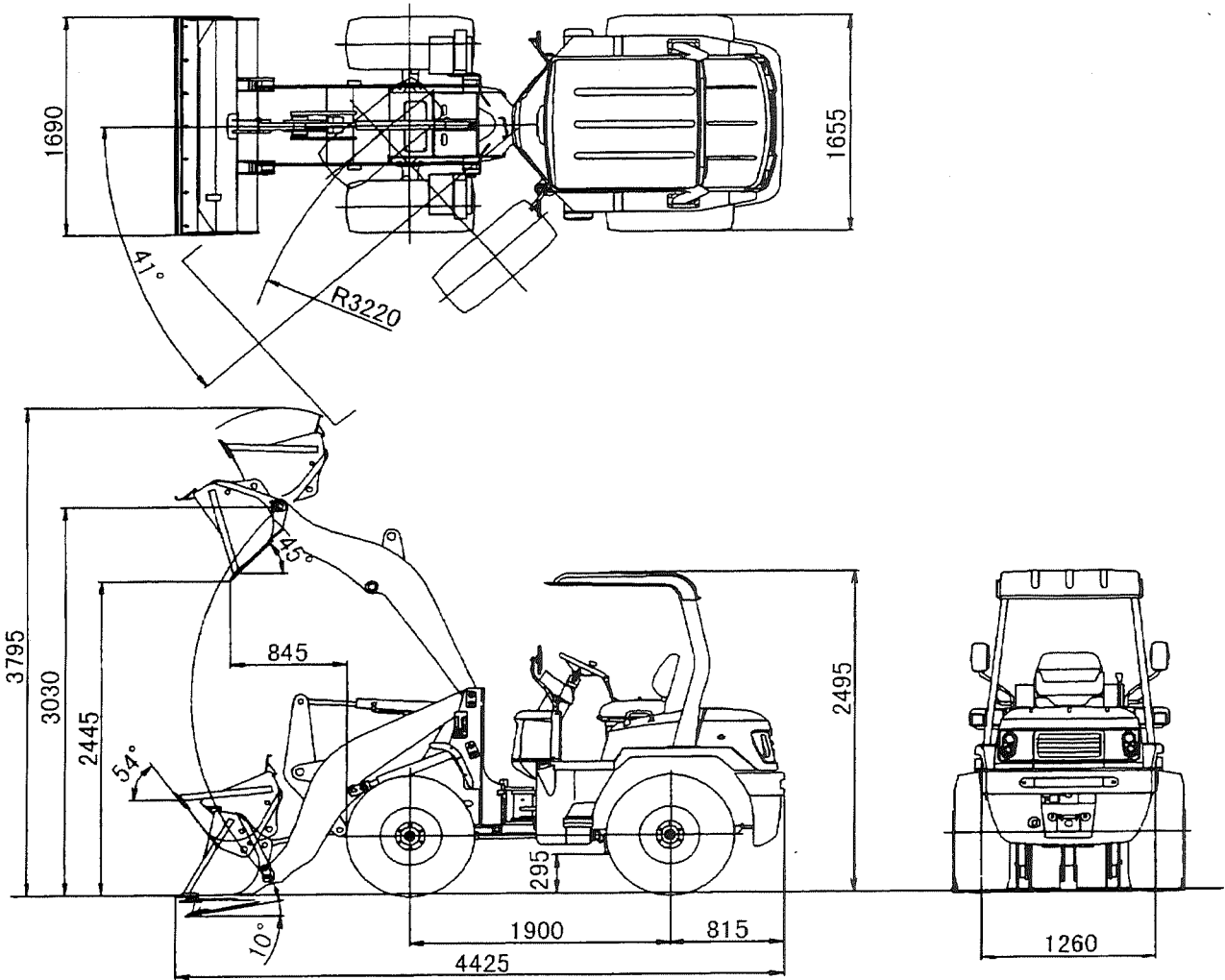

Bucket capacity (with BOC)		0.5m ³
Operating weight		3265kg
Engine	Maker/Model	KUBOTA D1503-DI-T-K2A
	Flywheel power/Rated speed	27.2kW (37PS)/ 2500rpm
	Piston displacement	1,499 L
	Fuel tank capacity	50 L (Light oil)
	Operating load	850kg
	Max. drawbar pull	33350N (3400kg)
Performance	Travel speed	1st gear F&R 8km/h
	(2 forward & 2 reverse)	2nd gear F&R 15km/h
	Gradeability	30°
	Turning radius (center of outside wheel)	3220mm
	Articulation angle	41°

Dimensions	Overall length (with BOC at ground)	4425mm
	Overall width (Bucket)	1690mm
	Overall height (Canopy)	2495mm
	Wheelbase	1900mm
	Ground clearance	295mm
	Dumping clearance (with BOC)	2445mm
	Dumping reach (with BOC)	845mm
	Bucket hinge pin height (Max.)	3030mm
Battery		12V-75D26
Transmission control HST		HST (Electrical)
Tire size/Pressure (standard)		15.5/60-18-8PR 200kPa

Troubleshooting

- L6-2

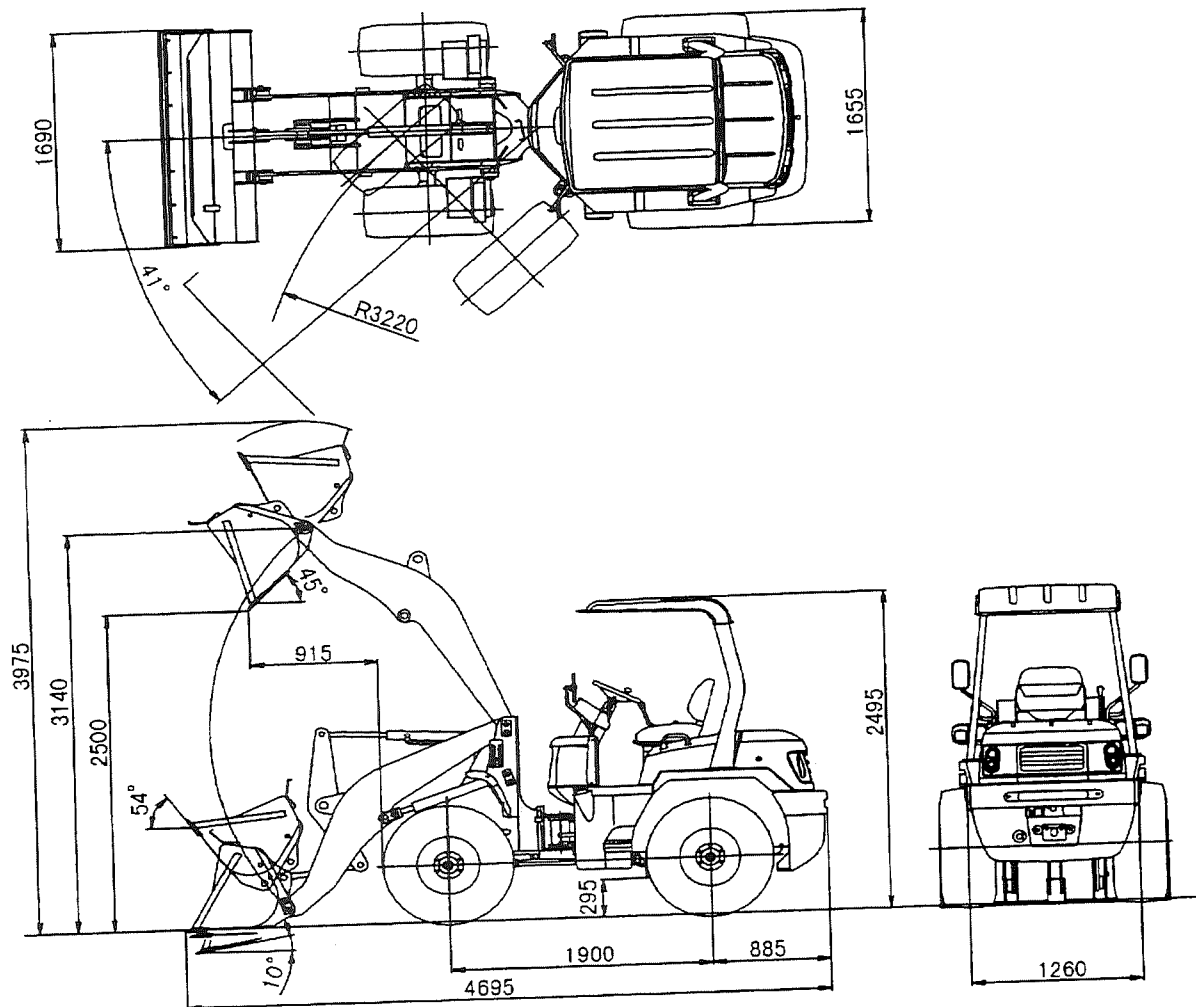

Bucket capacity (with BOC)		0.6m ³	
Operating weight		3565kg	
Engine	Maker/Model	KUBOTA D1503-DI- T-K2A	
	Flywheel power/Rated speed	27.2kW (37PS)/ 2500rpm	
	Piston displacement	1,499 L	
	Fuel tank capacity	50 L (Light oil)	
	Operating load	960kg	
Max. drawbar pull		3400kg	
Performance	Travel speed	1st gear F&R 8km/h	
	(2 forward & 2 reverse)	2nd gear F&R 15km/h	
	Gradeability		30°
	Turning radius (center of outside wheel)		3210mm
	Articulation angle		41°

Dimensions	Overall length (with BOC at ground)	4695mm
	Overall width (Bucket)	1690mm
	Overall height (Canopy)	2495mm
	Wheelbase	1900mm
	Ground clearance	295mm
	Dumping clearance (with BOC)	2500mm
	Dumping reach (with BOC)	915mm
	Bucket hinge pin height (Max.)	3140mm
Battery		12V-75D26
Transmission control HST		HST (Electrical)
Tire size/Pressure (standard)		15.5/60-18-8PR 200kPa

Main Equipment

■ Standard Equipment

○: Standard —: No setting

	Name of Equipment	L3-2	L4-2	L5-2	L6-2
Working equipment	Standard bucket: Capacity m ³ (heaped)	0.3	0.4	0.5	0.6
	Cutting edge	○	○	○	○
	Auto leveler	○	○	○	○
	Oil (HN) bush (working device)	○	○	○	○
Comfortable equipment	Key OFF engine stop	○	○	○	○
	Hour meter	○	○	○	○
	Coolant temperature gauge	○	○	○	○
	Fuel gauge	○	○	○	○
	Automatic speed change system	○	○	○	○
	Floor mat	○	○	○	○
	Tools (in bag)	○	○	○	○
	Canopy (resin)	○	○	○	○
	Water separator	○	○	○	○
Safety device	HST lever lock	○	○	○	○
	Safety bar (Frame lock)	○	○	○	○
	Working device lever lock	○	○	○	○
	Neutral start system	○	○	○	○
	Parking brake dragging preventive system	○	○	○	○
	Head light (halogen)	○	○	○	○
	Back-up lamp	○	○	○	○
	Back buzzer	○	○	○	○
	Hazard	○	○	○	○
	Fuel cap with key	○	○	○	○
	Engine hood lock	○	○	○	○
Environmental equipment	Complying with exhaust gas Tier II equivalent regulations (Japan)	○	○	○	○
	Complying with ultra low noise regulations (Japan)	○	○	○	○

Write Down Your Loader Data Here

Write Down Your Loader Data Here

Memo

LOADER MODEL _____

LOADER SERIAL NO. _____

ENGINE SERIAL NO. _____

SUPERVISER'S NAME

DATE OF PURCHASE _____

DEALER'S NAME

WORKSHOP'S NAME

PHONE _____

Dotted lines for memo writing.

