

SPECIFICATIONS

		E804-3	E806-3	E820-3
ENGINE				
Type		4-cycle, water cooled, direct fuel injection, diesel	4-cycle, water cooled, direct fuel injection, diesel	4-cycle, water cooled, direct fuel injection, diesel
Make / model		KUBOTA / D1803-MDI	KUBOTA / V2403-MDI	KUBOTA / V3307-DI-T
Flywheel power	(SAE J1995 gross)	30.6HP (31.0PS) / 2200r.p.m.	45.7HP (46.3PS) / 2400r.p.m.	63.0HP (64.3PS) / 2200r.p.m.
	(SAE J1349 net)	29.8HP (30.2PS) / 2200r.p.m.	45.0HP (45.6PS) / 2400r.p.m.	61.0HP (62.0PS) / 2200r.p.m.
Number of cylinder		3	4	4
Bore x stroke		3.43" (87mm) x 4.03" (102.4mm)	3.43" (87mm) x 4.03" (102.4mm)	3.70" (94mm) x 4.72" (120mm)
Piston displacement		111.4 in ³ (1826cc)	148.5 in ³ (2434cc)	203.2 in ³ (3331cc)
Voltage / starter / alternator		12V / 2.0kW / 60A	12V / 2.0kW / 60A	12V / 3.0kW / 80A
Battery CCA capacity x No.		490 x 1	490 x 1	620 x 1
TRANSMISSION				
Type		Electric controlled hydrostatic transmission automatically controls power and speed. Finger tip operated single transmission control lever makes Forward-Neutral-Reverse control. Low speed-hold switch limits loader travel speed for dig-and-load operation.(E820-3)		
Pump		Infinitely variable load sensing bi-directional piston pump with automatic power/speed control.		
Motor		Automatic piston motor.		
Travel speed	1st	—	—	7.4 mph (12km/h)
	2 forward, 2 reverse	9.3 mph (15km/h)	10.5 mph (17km/h)	21.1 mph (34km/h)
AXLE / BRAKES				
Type		Heavy duty, planetary final drive	Heavy duty, planetary final drive	Heavy duty, planetary final drive
Differential		Limited slip differential	Limited slip differential	Conventional type
Rear axle oscillation		±8 deg.	±8 deg.	±11deg
Service brake		Wet discs in reduction gear box	Wet discs in reduction gear box	Inboard mounted wet disc on front axle
Parking brake		Spring applied hydraulic released wet disc	Spring applied hydraulic released wet disc	Spring applied hydraulic released wet disc
TIRES				
Standard, tubeless		12.5/70-16-6PR	15.5/60-18-8PR	17.5/65-20-10PR
HYDRAULIC / STEERING				
Type		Single gear pump delivers oil flow to loader and steering functions. Priority valve delivers oil to steering system first. Air-to-oil cooler maintains transmission/hydraulic oil temperature.		
Pump type & flow		Gear 9.0 GPM (34.9LPM) / 2200r.p.m.	Gear 14.0 GPM (52.7LPM) / 2400r.p.m.	Gear 21.0 GPM (80.3LPM) / 2200r.p.m.
Pressure	loader	20.6 Mpa (210kg/cm ²)	20.6 Mpa (210kg/cm ²)	20.6 Mpa (210kg/cm ²)
	steering	17.2 Mpa (175kg/cm ²)	17.2 Mpa (175kg/cm ²)	18.1MPa (185kg/cm ²)
Hydraulic cycle time	raise	5.0 sec.	4.5 sec.	5.0 sec.
	lower	3.0 sec.	3.0 sec.	3.5 sec.
	dump	1.0 sec.	1.0 sec.	1.0 sec.
	total	9.0 sec.	8.5 sec.	9.5 sec.
Hydraulic cylinders bore x stroke	boom	2.56"(65mm) x 17.72"(450mm)	2.76"(70mm) x 20.91"(531mm)	3.35"(85mm) x 21.73"(552mm)
	bucket	2.56"(65mm) x 14.33"(364mm)	2.76"(70mm) x 17.72"(450mm)	3.15"(80mm) x 17.99"(457mm)
	steering	2.17"(55mm) x 8.98"(228mm)	2.36"(60mm) x 8.98"(228mm)	1.77"(45mm) x 13.39"(340mm)
SERVICE REFILL CAPACITIES				
Fuel tank		11.7 gal. (45L)	11.7 gal. (45L)	21.7 gal. (82L)
Engine oil		1.5 gal. (5.5L)	2.0 gal. (7.5L)	3.0 gal. (11L)
Coolant		1.2 gal. (4.5L)	1.7 gal. (6.5L)	2.6 gal. (10L)
Transmission & hydraulic		9.9 gal. (38L)	9.9 gal. (38L)	19.3 gal. (73L)
Axle, front / rear		1.2 gal. (4.5L) / 1.2 gal. (4.5L)	1.2 gal. (4.5L) / 1.2 gal. (4.5L)	1.6 gal. (6.2L) / 1.7 gal. (6.4L)
Reduction box		0.5 gal. (2L)	0.5 gal. (2L)	0.3 gal. (1L)

STANDARD EQUIPMENT

- 3 spool control valve
- Adjustable suspension seat with seat belt
- Automatic bucket leveler
- Automatic fuel air bleed system
- Cartridge type fuel, engine oil, HST oil and hydraulic oil filters
- Dual range hydrostatic transmission (E820-3)
- Eco-mode switch (E820-3)
- Electric fuel pump
- Electric parking brake
- Fuel water separator
- Full Auto range hydrostatic transmission (E804-3 & E806-3)
- General-purpose bucket with bolt-on cutting edge
- Glow plugs
- Inboard mounted wet disc brakes
- Lifting lug
- Locking hood and fuel tank
- LSD-limited slip differential (option for E820-3)

- Oil impregnated bushings for load handling system
- Radiator reserve tank
- ROPS/FOPS canopy
- Side-by-side radiator and oil cooler
- Tie down
- Tow pin

ACCESSORIES

- Back up alarm
- Floor mat
- Headlights, front turn signals, and rear combination lights
- Rear view mirrors
- Safety bar

OPTIONAL EQUIPMENT

- CFC-free air conditioner
- Heater and defroster
- Hydraulic quick coupler
- Mechanical quick coupler
- Radiator dust screen
- ROPS/FOPS cabin
- Solid tires
- Various buckets and attachments

DIMENSIONS

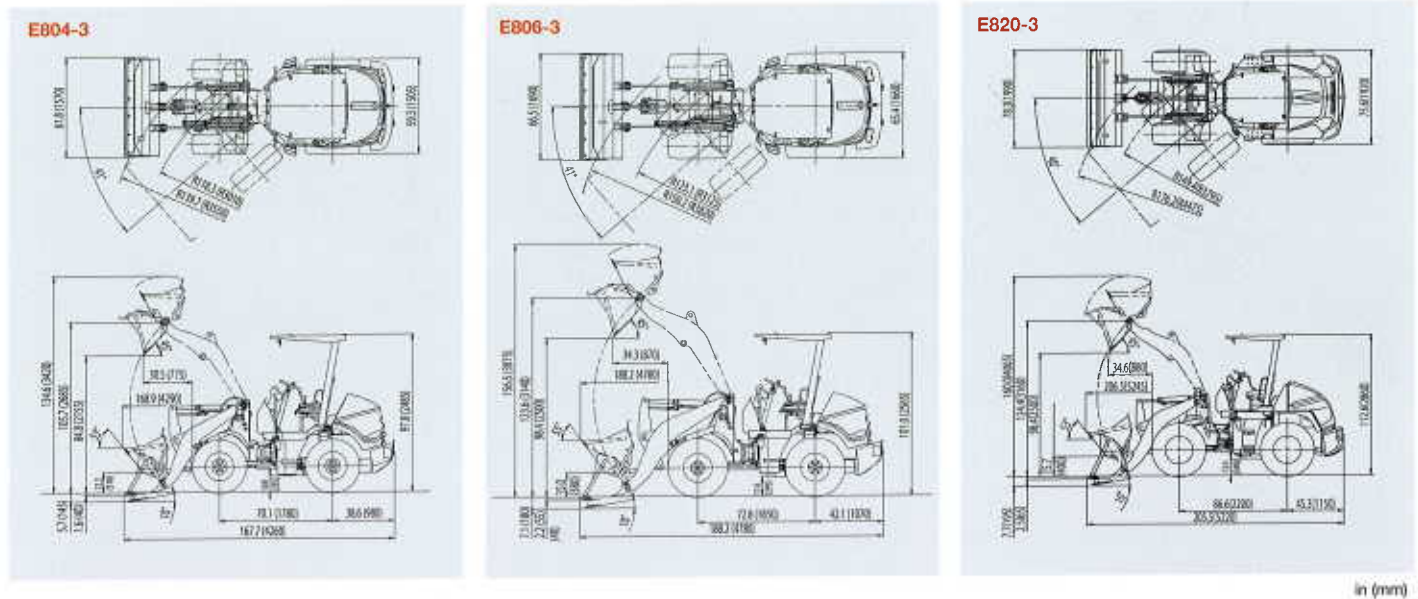

in (mm)

OPERATING DATA

Bucket type		E804-3		E806-3		E820-3		
		General Purpose		General Purpose		General Purpose		
		Bolt-on edge		Bolt-on edge		Bolt-on edge		
		Pin-on	Quick-coupler	Pin-on	Quick-coupler	Pin-on	Quick-coupler	
Bucket capacity, heaped	yd ³ (m ³)	0.52 (0.40)		0.78 (0.60)		1.18 (0.90)		
Bucket capacity, struck heaped	yd ³ (m ³)	0.5 (0.38)		0.67 (0.52)		0.95 (0.73)		
Bucket width	in (mm)	61.8 (1570)		66.5 (1690)		78.3 (1990)		
Hydraulic cycle time, raise/lower	sec	5.0/3.0	5.0/3.0	4.5/3.0	4.5/3.0	5.0/3.5	5.0/3.5	
Bucket cycle time, dump	sec	1.0	1.0	1.0	1.0	1.0	1.0	
Dumping height at full lift, 45° discharge	in (mm)	84.8 (2155)	79.7 (2025)	98.4 (2500)	93.7 (2380)	98.4 (2500)	94.1 (2390)	
Reach at full lift, 45° discharge	in (mm)	30.5 (775)	34.7 (880)	34.3 (870)	39.2 (995)	34.6 (880)	39.0 (990)	
Digging depth, horizontal / 10° forward tilt	in (mm)	1.6(40)/5.7(145)	2.2(55)/7.5(190)	2.2(55)/7.1(180)	2.0(50)/8.3(210)	2.6(65)/7.7(195)	2.6(65)/8.5(220)	
Overall length, bucket on ground	in (mm)	167.7 (4260)	174.8 (4445)	188.2 (4780)	195.1 (4955)	205.5 (5220)	211.8 (5380)	
Overall height, bucket fully raised	in (mm)	134.6 (3420)	138.6 (3525)	156.5 (3975)	161.6 (4105)	160.0 (4065)	164.0 (4165)	
Height to hinge pin, fully raised	in (mm)	105.7 (2685)	105.7 (2685)	123.6 (3140)	123.6 (3140)	124.6 (3165)	124.6 (3165)	
Turning radius, bucket in carry position	in (mm)	139.7 (3550)	141.7 (3600)	150.2 (3820)	152.4 (3870)	176.2 (4475)	178.7 (4540)	
Breakout force, bucket cylinder	lbf (kgf)	6390 (2900)	4630 (2100)	7500 (3400)	5550 (2515)	10470 (4750)	8280 (3755)	
Static tipping load, straight	lbs (kgf)	4310 (1955)	3720 (1685)	6200 (2810)	5570 (2525)	9390 (4260)	8150 (3695)	
Static tipping load, full turn	lbs (kgf)	3660 (1660)	3100 (1405)	5130 (2325)	4520 (2050)	7980 (3620)	6880 (3120)	
Operating weight	lbs (kg)	6540 (2965)	6800 (3085)	8620 (3910)	8890 (4030)	11570 (5245)	11860 (5380)	
OPTIONAL EQUIPMENT OPERATING DATA								
with ROPS / FOPS cabin	operating weight	lbs (kg)	6880 (3120)	7150 (3245)	8980 (4075)	9250 (4195)	11920 (5405)	12220 (5540)
	straight tipping load	lbs (kgf)	4580 (2075)	3990 (1810)	6450 (2925)	5840 (2650)	9750 (4420)	8470 (3840)
	full turn tipping load	lbs (kgf)	3880 (1760)	3330 (1510)	5300 (2405)	4760 (2160)	8300 (3765)	7170 (3250)
with solid tires	tire size		8.25-15		7.50-20		10.00-20	
	operating weight	lbs (kg)	7220 (3275)	7480 (3390)	9360 (4245)	9600 (4355)	12490 (5665)	12790 (5800)
	straight tipping load	lbs (kgf)	4670 (2120)	4070 (1845)	6540 (2965)	5930 (2690)	9980 (4530)	8680 (3940)
	full turn tipping load	lbs (kgf)	3940 (1785)	3400 (1540)	5370 (2435)	4820 (2185)	8480 (3850)	7340 (3330)

TCM retains the right to change these products and specifications without incurring any obligation relating to such changes. These products and specifications are subject to change without notice. Photos and illustrations may or may not include optional equipment and accessories.

Manufactured by

TCM
TCM CORPORATION

1-15-5, Nishi-shimbashi Minato-ku,
Tokyo, 105-0003 Japan
TEL: +81-3-3591-8176
FAX: +81-3-3591-8152
<http://www.tcmglobal.net>

Distributed by