

# Technical Data

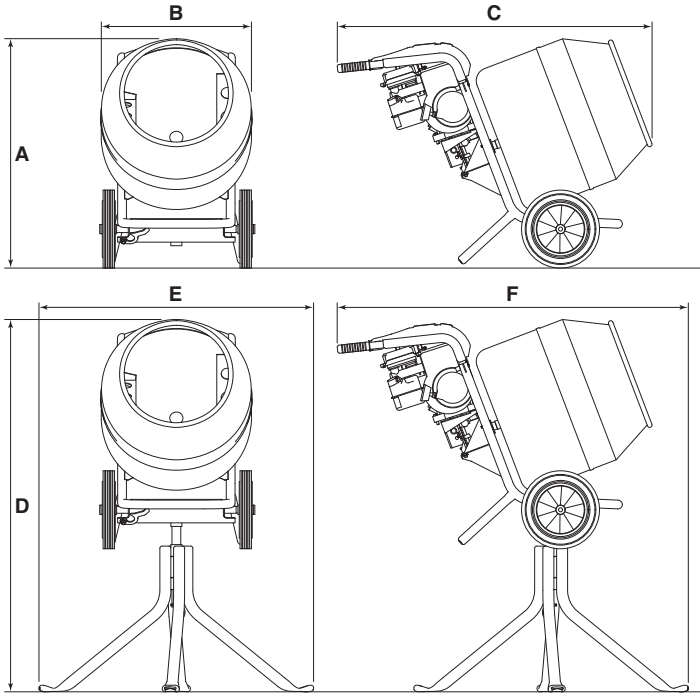

All Models	Minimix 150			
	A - Height (Off Stand)	890 mm		
B - Width (Off Stand)	597 mm			
C - Length (Off Stand)	1211 mm			
D - Height (On Stand)	1432 mm			
E - Width (On Stand)	1056.5 mm			
F - Length (On Stand)	1227 mm			
Electric Models	110v 50Hz	230v 50Hz	230v 60Hz	415v 50Hz
Unladen Weight	55.5 Kg	55 Kg	55 Kg	57 Kg
Stand Weight	9.5 Kg	9.5 Kg	9.5 Kg	9.5 Kg
Maximum Drum Capacity	130 ltr	130 ltr	130 ltr	130 ltr
Maximum Mixing Capacity	90 ltr	90 ltr	90 ltr	90 ltr
Drum speed (RPM)	24	24	24	24
Nominal Voltage	110v	230v	230v	415v
Nominal Current	5.0amp	2.6amp	3.0amp	1.0amp
Nominal Power	0.55 kW	0.55 kW	0.6 kW	0.55 kW
Current Frequency	50Hz	50Hz	60Hz	50Hz
Motor R.P.M.	2850	2850	3480	2780
Protective System	IP45	IP45	IP45	IP45
Power Consumption	550 W	550 W	670 W	550 W
Sound Power Level	84 dB(A)	84 dB(A)	84 dB(A)	84 dB(A)
Petrol Models	Briggs & Stratton	Honda GXH50	Honda GX120	Robin EH09DU
Unladen Weight	60.5 Kg	53.5 Kg	61 Kg	60.5 Kg
Stand Weight	9.5 Kg	9.5 Kg	9.5 Kg	9.5 Kg
Maximum Drum Capacity	130 ltr	130 ltr	130 ltr	130 ltr
Maximum Mixing Capacity	90 ltr	90 ltr	90 ltr	90 ltr
Drum speed (RPM)	24	24	5 - 24	24
Engine Model	2.4hp Vanguard	GXH 50	GX120	EH09
Fuel Type	Petrol	Petrol	Petrol	Petrol
Nominal Power	1.8 kW	1.8 kW	2.9	2.1 kW
Sound Power Level	92 dB(A)	92 dB(A)	92 dB(A)	92 dB(A)