

# S130

SKID-STEER

LOADER



Left Side Standard Instrument Panel

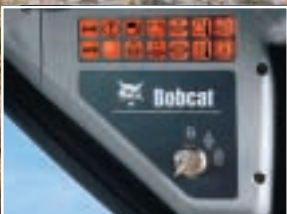

Right Side Standard Instrument Panel



Optional Deluxe Instrument Panel

***One Tough Animal***

# Bobcat® S130 Skid-Steer Loader

# SPECIFICATIONS

## Performance

Rated Operating Capacity<sup>1</sup>  
 ROC with optional counterweight  
 Tipping Load  
 Hydraulic Pump Capacity  
 Travel Speed  
 Operating Weight

## S130

1300 lb. (590 kg)  
 1400 lb. (635 kg)  
 2600 lb. (1179 kg)  
 16.9 GPM (64.0 L/min)  
 7.3 MPH (11.7 km/hr.)  
 4740 lb. (2150 kg)

## Dimensions

Length (with bucket)  
 Width (with bucket)  
 Height  
 Height to Bucket Pin

120.5 in. (3059 mm)  
 55.0 in. (1398 mm)  
 77.0 in. (1956 mm)  
 109.1 in. (2771 mm)

## Engine

Make/Model  
 Fuel/Cooling  
 Cylinders  
 SAE NET HP/Displacement  
 Fuel Tank Capacity

## Tier II Compliant

Kubota V2203-DI  
 Diesel/Liquid  
 4  
 46/134 in.<sup>3</sup> (2.2 L)  
 14 gal. (53 L)

## Operation

Steering and Drive

Forward, reverse, travel speed and steering controlled by two hand levers.

Hydraulics

Raise/lower lift arms and dump/rollback bucket controlled by two foot pedals or optional hand controls.

Transmission

Hydrostatic, four-wheel drive.

## Standard Features

Adjustable Cushion Seat	Front & Rear Lights
Automatically Activated	Lift Arm Support
Glow Plugs	Meters/Gauges/
Bobcat Interlock Control	Warning Lights
System (BICS™)	Parking Brake
Bob-Tach™	Seat Bar
Deluxe Cab	Seat Belt
Dual Path Cooling System	Spark Arrestor Muffler
Engine/Hydraulic	10-16.5 Standard
Shutdown	Duty Tires
Front Auxiliary	
Hydraulics	

## Options/Accessories

Advanced Control System (ACS)	Hydraulic Bucket Positioning <sup>2</sup>
Attachment Control Kit	Keyless Start System
Backup Alarm	Power Bob-Tach™
Bobcat Heavy-Duty Tires	Rear Auxiliary Hydraulics
Bobcat Heavy-Duty Offset Tires	Ride Control
Bobcat Poly-Fill Tires	Service Safety Training Kit
Bobcat Severe-Duty Tires	Side Windows
Bobcat Super Float Tires	Skid-Steer Loader Operator Training Kit
Cab Enclosure w/Heater	Sound Package
Catalytic Purifier	Special Applications Kit <sup>3</sup>
Gold Package Option	Suspension Seat (Vinyl or Cloth Cover)
Counterweight Kit	Water Kit
Deluxe Instrument Panel	
Flasher/Strobe Lights	
Horn	

## The Attractively-Priced Bobcat S130 Skid-Steer Loader

The S130 is a smart way to move into the popular Bobcat line of skid-steer loaders. The machine offers top value for your money. It has a turning radius of 6 feet and a rated operating capacity of 1300 pounds, along with features such as heavy-duty drive chains that never need adjustment, removable axle hubs for quick, easy servicing and a dual-path cooling system that cools with debris-free air. The S130 also works with a wide variety of Bobcat attachments, and sells for a very attractive price.

## The Multi-Purpose Bobcat S130 Skid-Steer Loader

A hard-working machine, the S130 is loaded with time-saving, money-saving features. Here are just a few:

- Great balance of power and maneuverability.
- Choice of seven bucket styles and more than 30 other attachments.
- Bobcat Interlock Control System (BICS)™ is standard.
- Operator-friendly cab.

### Greater Comfort

The cab is designed with the operator in mind, for optimum comfort and functionality. And with a wider opening, it's easy to enter and exit.

The seat bar pivots from the rear, providing secondary restraint protection as well as a comfortable armrest for operators of all sizes. Plus, the worklight design doubles the amount of illumination to the work area for better operation in low light.

The S130 also features an easy-to-read, highly functional instrument panel, along with a number of improved comfort options.

<b>1300 LB.</b> Rated Operating Capacity; 1400 lb. with optional counterweight kit	<b>109.1 IN.</b> Lift Height	<b>46 HP</b> Liquid-Cooled Kubota Diesel Engine
---	---------------------------------	--

### Optional Deluxe Instrument Package includes:

- Multi-language capability
- System diagnostic capability
- All gauges read in metric or English units
- Keyless start security
- Job clock
- Real-time clock
- Help screens

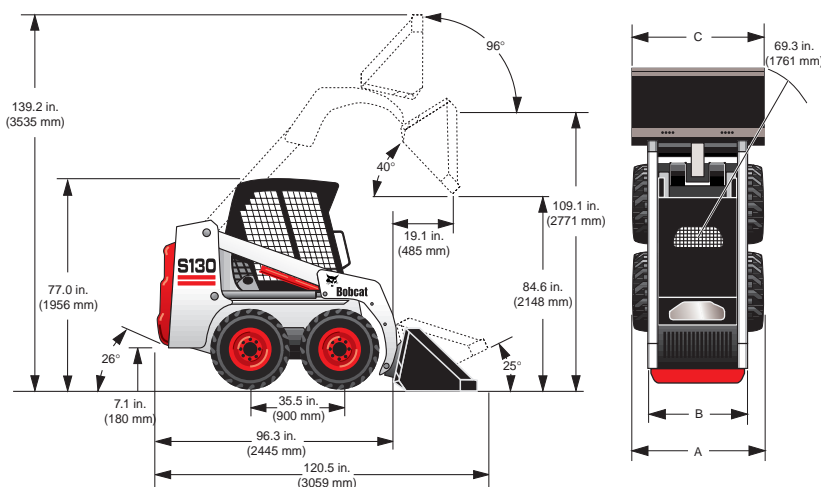

NOTE — Where applicable, dimensions are in accordance with Society of Automotive Engineers (SAE) and ISO standards. Specifications and design are subject to change without notice. Pictures of Bobcat loaders may show other than standard equipment. All dimensions are given for loader equipped with standard tires. All dimensions are shown in inches. Respective metric dimensions are enclosed by parentheses. Bobcat Company complies with the requirements of ISO 9001 as registered with BSI.

<sup>1</sup> Operating capacity rated with standard digging bucket according to SAE standard J819 - OPERATING CAPACITY TO EQUAL NO MORE THAN ONE-HALF THE TIPPING LOAD.

<sup>2</sup> Bucket positioning helps operator keep the same tilt of the load during lifting.

<sup>3</sup> Includes Lexan front door, top and rear windows.

<sup>4</sup> Special application kit (see #3) must be used.

A - 10-16.5 Tires - 60.3 in. (1524 mm) or 54 in. (1372 mm) with inset rims. 31.5 x 13-16.5 - 60 in. (1524 mm)

B - 10-16.5 Tires - 50.3 in. (1278 mm) or 44 in. (1118 mm) with inset rims. 31.5 x 13-16.5 - 48.3 in. (1176 mm)

C - 54 in. Bucket Width - 55.0 in. (1398 mm) 62 in. Bucket Width - 62.0 in. (1575 mm)



**Bobcat**

B-1777

Bobcat Company  
 P.O. Box 6000 • West Fargo, ND 58078  
[www.bobcat.com](http://www.bobcat.com)

Printed in U.S.A.

An **IR** Ingersoll Rand business

Kn-30M-1203-#640493-F

## Bobcat Attachments for this model:

- Angle Broom\*
- Auger
- Backhoe
- Brushcat™ Rotary Cutter
- Brush Saw
- Buckets
- Chipper\*
- Combination Bucket
- Concrete Mixer\*
- Cutter Crusher
- Digger
- Dozer Blade\*
- Dumping Hopper
- Farm Grapple (for use with utility forks or bucket)
- Front Scarifier
- Grader\*
- Hydraulic Breaker<sup>4</sup>
- Hydraulic Pallet Fork
- Industrial Grapple
- Landplane
- Landscape Rake
- Mower
- Pallet Fork
- Planer\*
- Rear Stabilizer
- Scraper
- Snow Blade
- Snowblower\*
- Sod Layer\*
- Soil Conditioner\*
- Spreader
- Sweeper
- Three Point Hitch
- Tiller
- Tilt-Tatch
- Tracks
- Trench Compactor
- Trencher
- Utility Fork
- Vibratory Roller
- Whisker Push Broom

\* Attachment Control Kit required.