

KOMATSU®

PC18MR-3 PC27MR-3
PC30MR-3 PC35MR-3
PC45MR-3 PC55MR-3

OPERATING WEIGHT

PC18MR-3 1,780 kg 3,920 lb
PC27MR-3 2,890 kg 6,370 lb
PC30MR-3 3,140 kg 6,920 lb
PC35MR-3 3,575 kg 7,880 lb
PC45MR-3 4,755 kg 10,480 lb
PC55MR-3 5,160 kg 11,380 lb



COMPACT
HYDRAULIC EXCAVATOR

WALK-AROUND

OPERATING WEIGHT		
PC18MR-3	1,780 kg	3,920 lb
PC27MR-3	2,890 kg	6,370 lb
PC30MR-3	3,140 kg	6,920 lb
PC35MR-3	3,575 kg	7,880 lb
PC45MR-3	4,755 kg	10,480 lb
PC55MR-3	5,160 kg	11,380 lb



Photo may include optional equipment



Photo may include optional equipment

Performance and Versatility

- Komatsu HydraMind hydraulic system
- Automatic load sensing two-speed travel
- Standard auxiliary hydraulics
- Integrated counterweight and tight tail swing

Operator Comfort

- Large operator platform
- Fully adjustable suspension seat
- Pilot proportional joystick controls
- Large monitor panel
- Easy entry and egress
- Low noise

Value, Durability, and Strength

- High strength X-track frame
- Castings are used for boom foot, tip, and swing yoke
- Single large diameter swing pin
- Three track options: rubber, steel, and Roadliner
- O-ring face seal hydraulic fittings
- Moisture/dust resistant electrical connectors

Service and Maintenance

- Wide opening engine hood and side covers
- Side-by-side radiator and oil cooler are easy to inspect and clean
- Extended lubrication and engine oil replacement intervals reduce maintenance and down time
- Tilt-forward operator's station provides full access to engine

General Features

- Two-post ROPS canopy or ROPS cab
- Neutral engine start system
- Excellent visibility enhances job site awareness
- Low emission Komatsu engine with dual element air cleaner
- One key operates the ignition and all machine locks

PRODUCTIVITY FEATURES

Tight Tail Swing

Operator is able to focus on the work in front of them and worry less about a rear swing impact, even in confined areas with only an **80mm 3"** projection over the tracks.



CLSS HydraMind Hydraulic System

When two or more actuators are operated simultaneously, the pressure-compensated CLSS system ensures each actuator works according to its control input, regardless of the size of the load. This gives the operator precise control at all times.

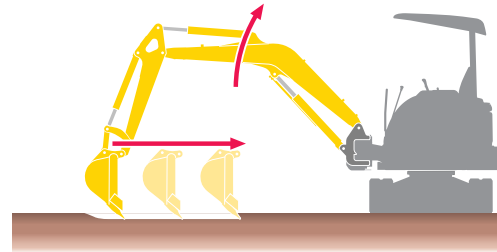

Confined Job Site Advantage

Operator can focus on digging and improve productivity, because they can worry less about obstacles to the rear of the machine, such as parked cars, walls and trees.

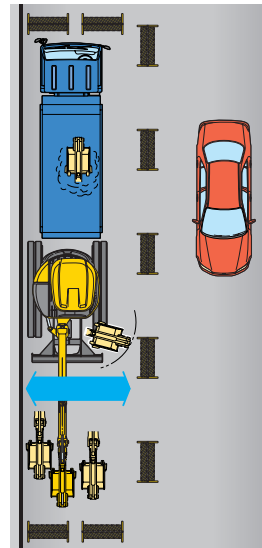

PC18MR-3	2,070mm	6'9"
PC27MR-3	2,515mm	8'3"
PC30MR-3	2,415mm	7'11"
PC35MR-3	2,550mm	8'4"
PC45MR-3	2,830mm	9'3"
PC55MR-3	2,800mm	9'2"

* : When boom swing

Automatic Two-speed Travel

The travel speed selector switch installed on the blade control allows the operator to engage high speed travel. Once engaged the system automatically senses the travel load and shifts between high speed and low speed travel.



Expandable undercarriage (PC18MR-3)

The PC18MR-3 can pass through narrow space due to narrow width and undercarriage can be expanded for good stability during excavation.

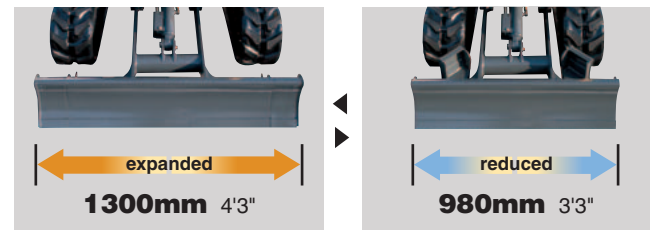

Working Ranges

	mm ft.in.		
	PC18MR-3	PC27MR-3	PC30MR-3
Max. digging height	3615 11'10"	4480 14'8"	4840 15'11"
Max. digging depth	2160 7'1"	2550 8'4"	2760 9'1"
Max. digging reach at ground level	3935 12'11"	4550 14'11"	4910 16'1"
Loading height	1220 4'0"	1650 5'5"	1700 5'7"

	PC35MR-3	PC45MR-3	PC55MR-3
Max. digging height	5000 16'5"	5515 18'1"	5945 19'6"
Max. digging depth	3110 10'2"	3350 12'0"	3800 12'6"
Max. digging reach at ground level	5170 17'0"	5575 18'3"	6070 19'11"
Loading height	1805 5'11"	1945 6'5"	1930 6'4"

Digging Force

	kg lb		
	PC18MR-3	PC27MR-3	PC30MR-3
Max. crowd force: Arm	1010 2230	1500 3310	1800 3970
Max. digging force: Bucket	1620 3570	2230 4920	3000 6610

	PC35MR-3	PC45MR-3	PC55MR-3
Max. crowd force: Arm	2100 4630	2200 4850	2440 5380
Max. digging force: Bucket	3050 6720	3460 7630	3980 8770

Auxiliary Flow

	ltr/min USgal/min		
	PC18MR-3	PC27MR-3	PC30MR-3
Auxiliary flow	35 9.2	50 13.2	70 18.5

	PC35MR-3	PC45MR-3	PC55MR-3
Auxiliary flow	70 18.5	70 18.5	70 18.5

Drawbar Pull

	kg lb		
	PC18MR-3	PC27MR-3	PC30MR-3
Max. drawbar pull	1700 3750	3200 7050	3400 7500

	PC35MR-3	PC45MR-3	PC55MR-3
Max. drawbar pull	3400 7500	4280 9440	4280 9440

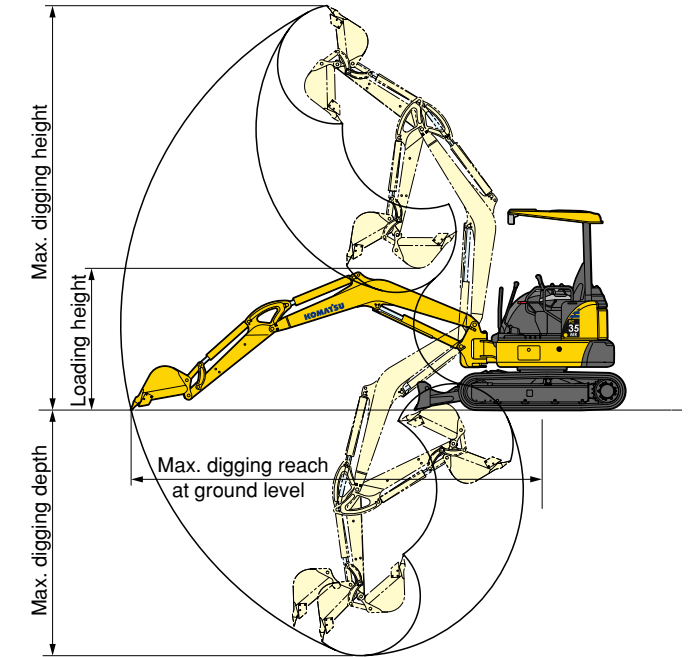

Stability

The MR-3 series offers exceptional lifting capacity and stability in a tight tail machine.

Lifting capacity comparison

	kg lb		
	PC18MR-3	PC27MR-3	PC30MR-3
3m 10'	220 480	370 820	365 800
Rating at max. reach	185 410	245 540	220 480

	PC35MR-3	PC45MR-3	PC55MR-3
3m 10'	580 1280	995 2190	1005 2220
Rating at max. reach	345 760	505 1110	435 960

The conditions of this comparison are a standard arm, sideways, blade on ground, and at a height of 0m (ground level).

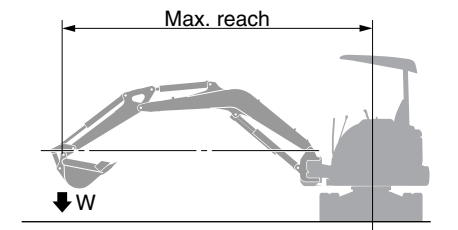

OPERATOR ENVIRONMENT

Large Entrance and Foot Space

The two-post canopy design allows the MR-3 series to have larger entrance for entry and egress.



Fully Adjustable Suspension Seat

The spacious operator's compartment provides outstanding ride quality. The large suspension seat enhances operator comfort.

Joystick Controls

PPC joystick controls are low effort and provide fine control.



PC18MR-3

Pattern Change Valve (optional equipment)

Pattern change valve allows the operator to change easily between ISO or SAE control patterns.



Excellent Visibility

The operator's station design allows the operator to maintain 360° field view.



Large Operator's Cab (optional equipment)

The cab provides outstanding foot space. Ergonomic design helps reduce fatigue. The large rear glass provides the operator excellent rear visibility.



Photo may include optional equipment



Photo may include optional equipment

Upper-rail Type Sliding Door



Large Rear Glass



Large-capacity Air Conditioner (optional equipment)

Provides comfortable operator environment throughout the year.



Cup Holder

Large cup holder is standard equipment.



Canopy

Cab

EASY MAINTENANCE

Tilt-up Operator Compartment

Operator's compartment floor tilts forward providing easy access to hydraulic compartments.

Fully Opening Engine Door and Side Cover

Allow easy access for daily checks and regular maintenance.



Photo may include optional equipment

High Strength X-track Frame

X-track frame is a large hydraulic excavator concept and deters dirt and debris build up saving the operator valuable time when cleaning the machine.

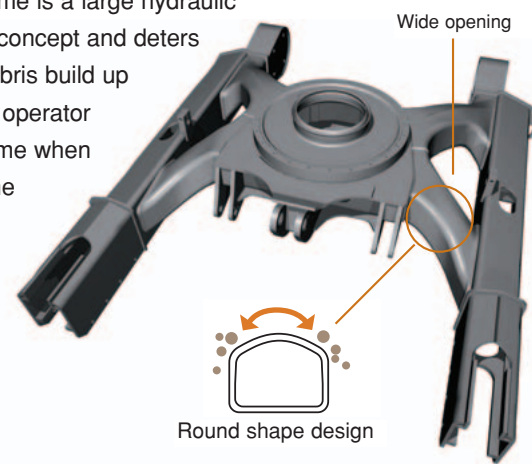

500 Hour Maintenance Intervals

Extended lubrication, engine oil and filter replacement intervals reduce maintenance costs.

Comparison of periodic service intervals		hours
		MR-3 SERIES
Lubricating to swing circle		500
Lubricating to bushing of work equipment		500
Replacement of engine oil / filter		500

Larger Diameter Swing Pin

Has high durability and maintains suitable clearances between pin and bushing after long-term operation.



O-ring Face Seal

O-ring face seals are highly reliable.

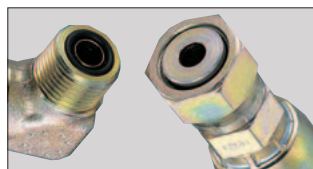

DT Connector

DT connectors are moisture and dust resistant.

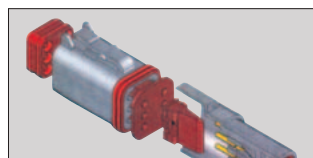

FEATURES

Two-post ROPS & OPG Canopy

ROPS [Roll-Over Protective Structures]

This canopy meets the requirements of ROPS, with the advantage of a two-post design.



Neutral Engine Start System

Locks out drives and hydraulics during machine start up.



Tie-Downs or Anchor Points

Large tie-downs or anchor points in the track frame and blade allow the machine to be secured quickly for transport.

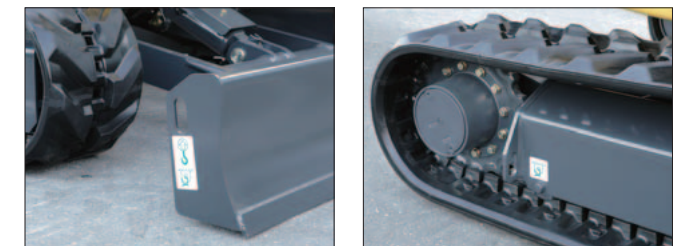

OPTIONAL EQUIPMENT

Roadliner (not available for PC18MR-3)

Replacement is fast, easy and cost efficient as individual shoes are replaced when damaged or worn instead of replacing the entire track.



Steel Shoes with Rubber Pad



Optional Blade

(Bolt-on cutting edge type)



PA Blade (not available for PC18MR-3 and PC27MR-3)

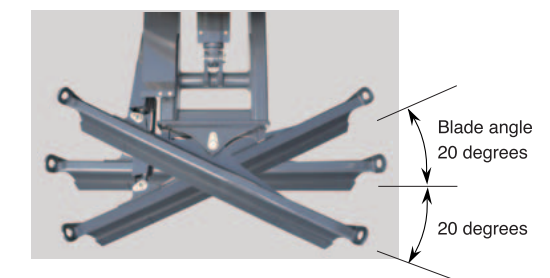

SPECIFICATIONS

		PC18MR-3	PC27MR-3	PC30MR-3	PC35MR-3	PC45MR-3	PC55MR-3
Performance	Operating weight	1780 3920	2890 6370	3140 6920	3575 7880	4755 10480	5160 11380
		ROPS Canopy, Rubber shoe		ROPS Canopy, Rubber shoe		ROPS Canopy, Rubber shoe	
	Flywheel horse power	11.2/2600	19.2/2600	21.4/2400	21.4/2400	28.5/2400	28.5/2400
		15/2600		25.7/2600		28.6/2400	
	Bucket capacity (SAE heaped)	0.044 0.058	0.08 0.10	0.09 0.12	0.11 0.14	0.14 0.18	0.16 0.21
		(CECE heaped)		0.04 0.052		0.07 0.09	
	Bucket width (incl. side cutters)	400 16	430 17	430 17	530 21	530 21	580 23
		450 18		500 20		500 20	
	Travel speed Hi	4.3 2.7	4.8 3.0	4.6 2.9	4.8 3.0	4.6 2.9	4.6 2.9
	Lo	2.3 1.4	2.6 1.6	2.5 1.6	2.8 1.7	2.8 1.7	2.8 1.7
Swing speed	8.9	9.2	9.3	9	9	9	
Ground pressure	0.32 4.6	0.32 4.6	0.30 4.3	0.36 5.1	0.25 3.6	0.29 4.1	
Max. traction force	1700 3750	3200 7050	3400 7500	3400 7500	4280 9440	4280 9440	
Gradeability	30	30	30	30	30	30	
Bucket digging force(ISO)	1620 3570	2230 4920	3000 6610	3050 6720	3460 7630	3980 8770	
Arm crowd force(ISO)	1010 2230	1500 3310	1800 3970	2100 4630	2200 4850	2440 5380	
Engine	Model	Komatsu 3D67E	Komatsu 3D82AE-6	Komatsu 3D88E-6	Komatsu 3D88E-6	Komatsu 4D88E-6	Komatsu 4D88E-6
	Type	Swirl chamber	Direct injection	Direct injection	Direct injection	Direct injection	Direct injection
	Piston displacement	0.778 47	1.33 81	1.642 100	1.642 100	2.189 134	2.189 134
Electric system	Operation voltage	12	12	12	12	12	12
	Battery	41	58	58	58	72	72
	Alternator	40	40	40	40	40	40
	Starter	1.2	2.3	2.3	2.3	2.3	2.3
Blade	Width x height	980 or 1300 x 250	1550 x 355	1550 x 355	1740 x 355	1960 x 355	1960 x 355
		3'3" or 4'3" x 10"		5'1" x 1'2"		5'9" x 1'2"	
		5'1" x 1'2"		5'1" x 1'2"		6'5" x 1'2"	
Drive system	Drive method	Hydrostatic	Hydrostatic	Hydrostatic	Hydrostatic	Hydrostatic	Hydrostatic
	Type of travel brake	Hydraulic lock type	Hydraulic lock type	Hydraulic lock type	Hydraulic lock type	Hydraulic lock type	Hydraulic lock type
	Type of travel shoe	Rubber	Rubber	Rubber	Rubber	Rubber	Rubber
Undercarriage	Adjustment of the track tension	Grease	Grease	Grease	Grease	Grease	Grease
	Number of shoes (for each side)	35 (steel)	40 (steel)	44 (steel)	44 (steel)	39 (steel)	39 (steel)
	Number of carrier rollers (for each side)	0	1	1	1	1	1
	Number of track rollers (for each side)	3	4	4	4	4	4
Hydraulic system	Type of hydraulic pump	Variable capacity x 1 gear x 1	Variable capacity x 1 gear x 1	Variable capacity x 1 gear x 1	Variable capacity x 2 gear x 1	Variable capacity x 2 gear x 1	Variable capacity x 2 gear x 1
	Max. oil flow	41.6 x 1 + 12.7	70.6 x 1 + 21.4	69.8 x 1 + 19.8	36.1 x 2 + 19.8	53.5 x 2 + 33.8	53.5 x 2 + 33.8
		11.0 x 1 + 3.4		18.4 x 1 + 5.7		14.1 x 2 + 8.9	
		14.1 x 2 + 8.9		14.1 x 2 + 8.9		14.1 x 2 + 8.9	
	Hydraulic motor (travel)	Variable capacity x 2	Variable capacity x 2	Variable capacity x 2	Variable capacity x 2	Variable capacity x 2	Variable capacity x 2
(swing)	fixed capacity x 1	fixed capacity x 1	fixed capacity x 1	fixed capacity x 1	fixed capacity x 1	fixed capacity x 1	
Max. pressure setting	235 3340	250 3560	265 3770	265 3770	270 3840	270 3840	
Auxiliary hydraulic flow	35	50	70	70	70	70	
	9.2		13.2		18.5		
Refilling capacity	Fuel tank	19 5.0	44 11.6	44 11.6	44 11.6	65 17.2	65 17.2
	Hydraulic tank	15.2 4.0	14 3.7	14 3.7	20 5.3	20 5.3	20 5.3
	Engine	3.3 0.9	5 1.3	6.7 1.8	6.7 1.8	7.5 2.0	7.5 2.0
	Coolant	3.1 0.8	3.3 0.9	3.3 0.9	3.3 0.9	8.5 2.2	8.5 2.2

DIMENSIONS

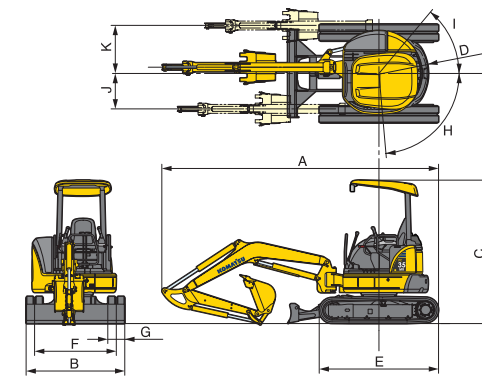

	PC18MR-3	PC27MR-3	PC30MR-3	PC35MR-3	PC45MR-3	PC55MR-3
A Overall length	3650 12'0"	4240 13'11"	4560 15'0"	4825 15'10"	5220 17'2"	5550 18'3"
B Overall width	1300 4'3"	1550 5'1"	1550 5'1"	1740 5'9"	1960 6'5"	1960 6'5"
C Overall height	2410 7'11"	2520 8'3"	2520 8'3"	2520 8'3"	2550 8'4"	2550 8'4"
D Tail swing radius	715 2'4"	855 2'10"	855 2'10"	950 3'1"	1060 3'6"	1060 3'6"
E Crawler length	1555 5'1"	1950 6'5"	2105 6'11"	2105 6'11"	2520 8'3"	2520 8'3"
F Track gauge	1070 3'6"	1250 4'1"	1250 4'1"	1440 4'9"	1560 5'1"	1560 5'1"
G Track shoe width	230 9"	300 12"	300 12"	300 12"	400 16"	400 16"
H/I Boom swing angle	LH70/RH50	LH85/RH50	LH80/RH50	LH75/RH55	LH85/RH50	LH85/RH50
J Bucket offset LH	465 1'6"	580 1'11"	580 1'11"	580 1'11"	630 2'1"	630 2'1"
K Bucket offset RH	785 2'7"	845 2'9"	845 2'9"	770 2'6"	880 2'11"	880 2'11"

LIFTING CAPACITY

Blade on ground with additional counterweight (X-weight)

Model	Arm length		2m 6.5'		3m 10'		Maximum		
			Front	Side	Front	Side	Front	Side	
			PC18MR-3	965mm 3'2"	3m 10'				*355 *780
		2m 6.5'				*315 *700	*215 470		
		1m 3.25'	*650 *1435	420 930	*365 *810	230 510	*320 *710	180 400	
		0m 0'	*805 *1780	395 870	*410 *900	220 480	*335 *740	185 410	
		-1m -3.25'	*635 *1400	400 880			*340 *750	245 540	
		0m 0'	*795 *1750	390 860	*400 *880	215 470	*300 *660	165 360	
PC27MR-3	1100mm 3'7"	3m 10'				*695 *1530	325 720		
		2m 6.5'	*1215 *2680	800 1760	*795 *1750	410 900	*705 *1550	250 550	
		1m 3.25'			*1065 *2350	385 850	*735 *1620	230 510	
		0m 0'	*2230 *4920	680 1500	*1185 *2610	370 820	*775 *1710	245 540	
		-1m -3.25'	*1820 *4010	695 1530	*2020 *2250	370 820	*810 *1790	315 690	
		0m 0'	*2305 *5080	660 1450	*1155 *2550	355 780	*695 *1530	205 450	
PC30MR-3	1240mm 4'1"	3m 10'				*825 *1820	290 640		
		2m 6.5'			*1000 *2200	420 930	*825 *1820	225 500	
		1m 3.25'			*1320 *2910	385 850	*845 *1860	210 460	
		0m 0'	*2660 *5860	680 1500	*1440 *3170	365 800	*870 *1920	220 480	
		-1m -3.25'	*2140 *4720	695 1530	*1250 *2760	365 800	*880 *1940	275 610	
		0m 0'	*2820 *6220	670 1480	*1415 *3120	360 790	*780 *1720	185 410	
PC35MR-3	1370mm 4'6"	3m 10'				*690 *1550	385 850		
		2m 6.5'			*960 *2120	655 1440	*710 *1570	315 690	
		1m 3.25'			*1290 *2840	610 1350	*845 *1860	335 740	
		0m 0'	*2610 *5750	1100 2420	*1430 *3150	580 1280	*885 *1950	345 760	
		-1m -3.25'	*2245 *4950	1120 2470	*1325 *2920	580 1280	*920 *2030	415 910	
		0m 0'	*2735 *6030	1085 2390	*1390 *3060	575 1270	*720 *1590	275 610	
PC45MR-3	1375mm 4'6"	3m 10'				*990 *2180	*990 *2180	*1020 *2250	585 1290
		2m 6.5'			*1530 *3370	1100 2430	*1060 *2340	500 1100	
		1m 3.25'			*2125 *4690	1025 2260	*1120 *2470	480 1060	
		0m 0'			*2345 *5170	995 2190	*1195 *2640	505 1110	
		-1m -3.25'	*3010 *6640	1965 *4330	*2195 *4840	995 2190	*1280 *2820	600 1320	
		0m 0'	*1250 *2760	*1250 *2760	*2275 *5020	980 2160	*1045 *2300	430 950	
PC55MR-3	1640mm 5'5"	3m 10'				*1435 *3160	1140 2510	*850 *1870	500 1100
		2m 6.5'				*885 *1950	440 970		
		1m 3.25'			*2030 *4480	1045 2300	*930 *2050	420 930	
		0m 0'			*2260 *4980	1005 2220	*985 *2170	435 960	
		-1m -3.25'	*2790 *6150	1960 *4320	*2170 *4780	1000 2200	*1050 *2320	500 1100	
		0m 0'	*1285 *2830	*1285 *2830	*2205 *4860	1010 2230	*895 *1970	390 860	

*Load is limited by hydraulic capacity rather than tipping. Rated loads do not exceed 87% of hydraulic capacity or 75% of tipping load.

WORKING RANGE

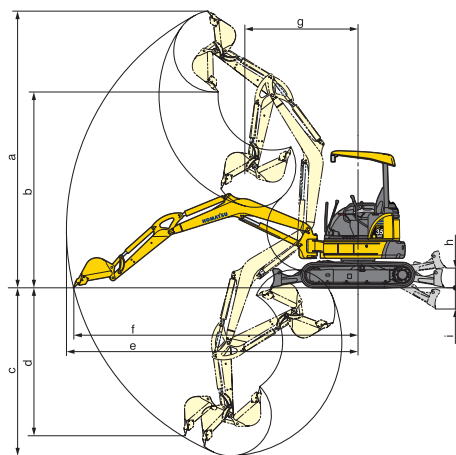

STD ARM WORKING RANGE

	PC18MR-3	PC27MR-3	PC30MR-3	PC35MR-3	PC45MR-3	PC55MR-3
a Max. digging height	3615 11'10"	4480 14'8"	4840 15'11"	5000 16'5"	5515 18'1"	5945 19'6"
b Max. dumping height	2610 8'7"	3190 10'6"	3350 11'0"	3530 11'7"	3785 12'5"	4230 13'11"
c Max. digging depth	2160 7'1"	2550 8'4"	2760 9'1"	3110 10'2"	3350 11'0"	3800 12'6"
d Max. vertical digging depth	1785 5'10"	2080 6'10"	2400 7'10"	2690 8'10"	2645 8'8"	3020 9'11"
e Max. digging reach	4025 13'2"	4650 15'3"	5050 16'7"	5300 17'5"	5735 18'10"	6220 20'5"
f Max. digging reach at ground level	3935 12'11"	4550 14'11"	4910 16'1"	5170 17'0"	5575 18'3"	6070 19'11"
g Min. swing radius (When boom swing)	1670 5'6"	1980 6'6"	2055 6'9"	2030 6'8"	2340 7'8"	2270 7'5"
	(1355 4'5")	(1660 5'5")	(1560 5'1")	(1600 5'3")	(1770 5'10")	(1740 5'9")
h Max. blade lift	280 11"	360 1'2"	360 1'2"	360 1'2"	430 1'5"	430 1'5"
i Max. blade depth	255 10"	315 1'0"	310 1'0"	390 1'3"	330 1'1"	330 1'1"

LONG ARM WORKING RANGE

	PC18MR-3	PC27MR-3	PC30MR-3	PC35MR-3	PC45MR-3	PC55MR-3
a Max. digging height	3820 12'6"	4690 15'5"	5070 16'8"	5270 17'3"	5780 19'0"	6215 20'5"
b Max. dumping height	2815 9'3"	3390 11'1"	3580 11'9"	3790 12'5"	4060 13'4"	4495 14'9"
c Max. digging depth	2410 7'11"	2840 9'4"	3130 10'3"	3455 11'4"	3770 12'4"	4160 13'8"
d Max. vertical digging depth	2000 6'7"	2370 7'9"	2770 9'1"	3120 10'3"	3060 10'0"	3380 11'1"
e Max. digging reach	4270 14'0"	4930 16'2"	5390 17'8"	5640 18'6"	6130 20'1"	6570 21'7"
f Max. digging reach at ground level	4190 13'9"	4840 15'11"	5215 17'1"	5520 18'1"	5980 19'7"	6430 21'1"
g Min. swing radius (When boom swing)	1770 5'10"	2030 6'8"	2190 7'2"	2140 7'0"	2410 7'11"	2380 7'10"
	(1435 4'8")	(1700 5'7")	(1665 5'6")	(1710 5'7")	(1860 6'1")	(1840 6'0")
h Max. blade lift	280 11"	360 1'2"	360 1'2"	360 1'2"	430 1'5"	430 1'5"
i Max. blade depth	255 10"	310 1'0"	310 1'0"	390 1'3"	330 1'1"	330 1'1"

STANDARD/OPTIONAL EQUIPMENT

● : Standard equipment ○ : Optional equipment

	PC18MR-3	PC27MR-3	PC30MR-3	PC35MR-3	PC45MR-3	PC55MR-3
Arm						
STD arm with aux. piping PC18MR: 965mm 3'2" PC30MR: 1240mm 4'1" PC45MR: 1375mm 4'6" PC27MR: 1100mm 3'7" PC35MR: 1370mm 4'6" PC50MR: 1640mm 5'5"	●	●	●	●	●	●
Long arm with aux. piping PC18MR: 1215mm 4'0" PC30MR: 1610mm 5'3" PC45MR: 1770mm 5'10" PC27MR: 1370mm 4'6" PC35MR: 1720mm 5'8" PC50MR: 2000mm 6'7"	○	○	○	○	○	○
STD arm without aux. piping	○	○	○	○	○	○
Long arm without aux. piping	○	○	○	○	○	○
Bucket Capacity Bucket width (incl. side cutters)						
0.022m³ 0.029yd³ 250mm 10" (300mm 12")	○					
0.035m³ 0.046yd³ 250mm 10" (320mm 13")		○	○			
0.04m³ 0.052yd³ 350mm 14" (400mm 16")	○					
0.044m³ 0.058yd³ 280mm 11" (350mm 14")		○	○			
0.044m³ 0.058yd³ 400mm 16" (450mm 18")	●					
0.055m³ 0.072yd³ 350mm 14" (420mm 17")				○		
0.055m³ 0.072yd³ 300mm 12" (370mm 14")					○	○
0.08m³ 0.10yd³ 430mm 17" (500mm 20")		●				
0.09m³ 0.12yd³ 430mm 17" (500mm 20")		○	●	○		
0.11m³ 0.14yd³ 530mm 21" (600mm 24")			○	●		
0.11m³ 0.14yd³ 430mm 17" (500mm 20")					○	○
0.13m³ 0.17yd³ 630mm 25" (700mm 28")				○		
0.14m³ 0.18yd³ 530mm 21" (600mm 24")					●	
0.16m³ 0.21yd³ 580mm 23" (650mm 26")					○	●
Track shoes						
230mm 9" rubber shoes	●					
300mm 12" rubber shoes		●	●	●		
400mm 16" rubber shoes					●	●
230mm 9" steel shoes	○					
300mm 12" steel shoes		○	○	○		
400mm 16" steel shoes					○	○
230mm 9" steel shoes with rubber pad	○					
300mm 12" steel shoes with rubber pad		○	○	○		
400mm 16" steel shoes with rubber pad					○	○
300mm 12" road liner		○	○	○		
400mm 16" road liner					○	○
Blade						
Expandable blade assembly	●					
Blade assembly		●	●	●	●	●
Blade assembly with BOC		○	○	○	○	○
PA blade			○	○	○	○
Others						
Standard equipment			Optional equipment			
<ul style="list-style-type: none"> • Additional counterweight • Air cleaner, single element • Automatic two-speed travel • Rear view mirrors, RH and LH • Seat belt, 78mm 3" width • Steering pedals 	<ul style="list-style-type: none"> • Suspension seat, reclining with arm rests • Travel alarm • Two-post ROPS & Top guard canopy 	<ul style="list-style-type: none"> • Additional working light • Air conditioner (for cab) (not available for PC18MR-3) • Cigarette lighter (for cab) • Pattern change valve (ISO - Backhoe) • Radiator net • Radio (for cab) 	<ul style="list-style-type: none"> • Rigid seat, reclining • ROPS & Top guard cab with heater, front window washer/wiper, cup holder and ashtray (not available for PC18MR-3) • Seat belt, 50mm 2" width 			

www.Komatsu.com

Printed in Japan 200809 IP.As(10)



CEN00314-01

Materials and specifications are subject to change without notice
KOMATSU is a trademark of komatsu Ltd, Japan