

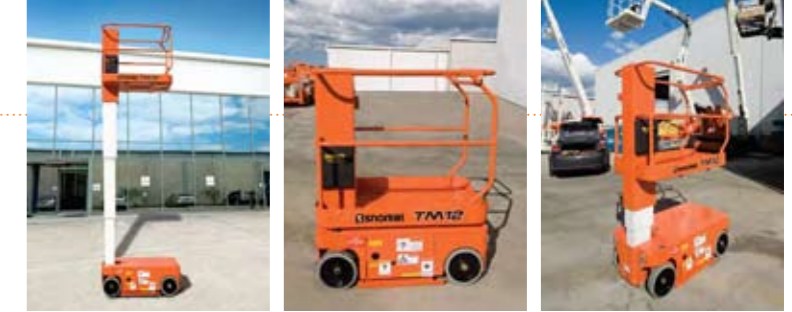

VERTICAL MAST BOOM

TM12

Safe and simple, its size is designed for working in restricted spaces such as hotels, offices, retail stores and public buildings.



The Snorkel TM12 provides a safe, efficient means of working at height in restricted spaces typically encountered in offices, retail stores, hotels, public buildings or crowded industrial aisles. Its ultra compact size makes it ideal for applications such as stock picking and record storage retrieval. When the job is complete, the lift can be quickly lowered and returned to a convenient storage area.

Key features

- › 5.7m maximum working height
- › Ultra compact design
- › Drives through standard doorway and narrow aisles
- › Transportable in most passenger elevators
- › Non-marking tyres
- › Step on and step off platform

Standard features

- › Proportional controls
- › Drives at full height
- › 24V DC 4hp electric motor provides clean, pollution free power great for indoor use
- › Descent and tilt alarms
- › High amp hour rating gives long usage between charges
- › 25 amp charger for easy overnight charging
- › Emergency lowering at chassis controls
- › Non-marking, solid rubber tyres
- › D-ring tie down points
- › Selectable motion alarm
- › 1 year parts and labour warranty
- › 5 years structural warranty

Additional options

- › Overload alarm
- › Custom colours
- › Environmental green oil

WORKING SPAN

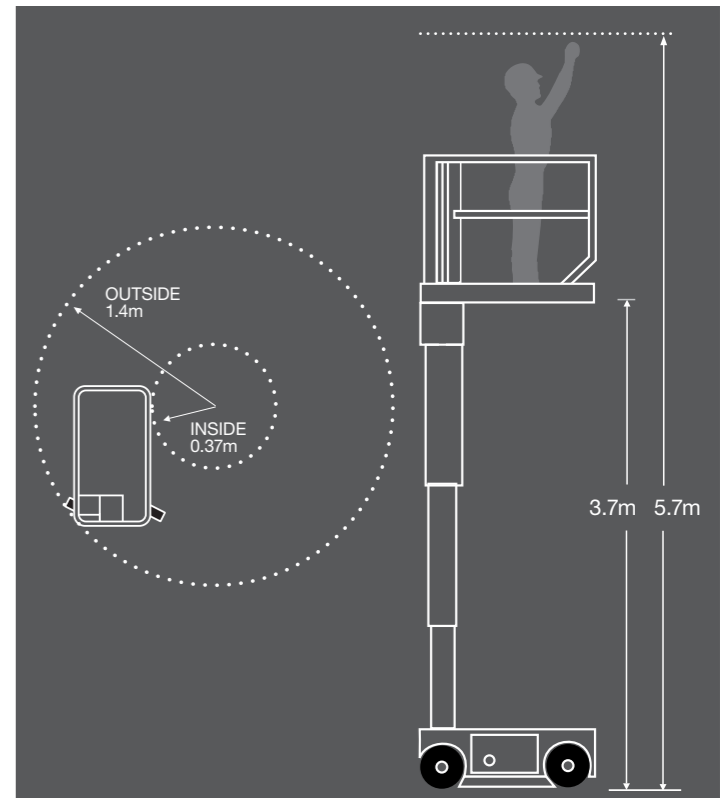

COMPACT DESIGN

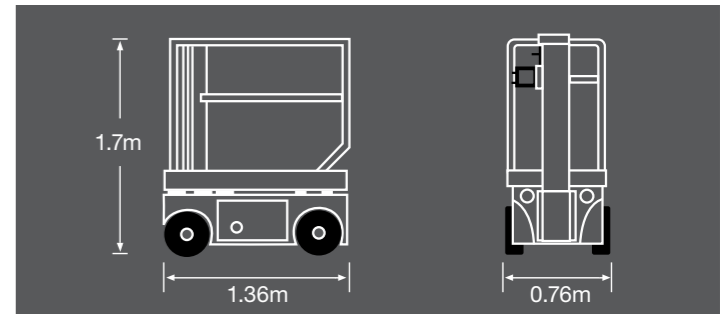

VERTICAL MAST BOOM
TM12

Contact us

At Snorkel, we've made it easier for you to find the information you need. Speak to us or visit our website www.snorkellift.com for more information.

- Sales
0800 SNORKEL
- Technical support
0800 766 7535
- Parts and service
0800 SNORKEL

Specifications

Working height	5.7m	18.7'
Platform height	3.7m	12.1'
Maximum drive height	3.7m	12.1'
Platform capacity – SWL	227kg	500lbs
Platform size – inside	0.74m x 1.04m	2.4' x 3.4'
Overall width	0.76m	2.5'
Stowed height	1.7m	5.6'
Stowed length	1.36m	4.5'
Gross weight	776kg	1711lbs
Drive speed – maximum with platform raised	3.65km/hr 1.0km/hr	
Gradeability	14.5° / 25%	
Inside turning radius	0.37m	1.2'
Ground clearance	76mm	
Lift speed – raise / lower	18 seconds / 25 seconds	
Drive system	Dual front hydraulic motors	
Tyres	305mm diameter solid rubber, non-marking	
Battery charger	90V - 240V - 25 amp automatic	
Parking brake	Two wheel, spring applied, hydraulic release with manual overdrive	
Control system	One hand proportional controls	
Power source	Batteries 4 x 220Ah	Electric motor 24V 4hp DC

DANGER: Models described in this brochure are NON-INSULATED and do not provide electrocution protection from contact with or close proximity to energised conductors which is pointed out on decals and placards attached to the machine. Only qualified and trained operators are to be authorised to use and operate a work platform. Aerial work platforms must be elevated only on firm, level surface. This literature is for illustrative purposes only. Consult Operating Maintenance and Parts Manuals for proper procedures. Specifications may vary and are subject to change without notice or obligation.



DEALER STICKER



VERTICAL MAST BOOM
TM12

