



Ratings and Performance Data

Engine Make	Perkins		
Engine Model:	1104D-E44TAG1		
Alternator Make	Marelli		
Alternator Model:	MJB 200 LA4		
Control Panel:	Power Wizard 1.1		
Base Frame:	Heavy Duty Fabricated Steel		
Circuit Breaker Type:	3 Pole MCCB		
Frequency:	50 HZ		60 HZ
Engine Speed: RPM	rpm	1500	
Fuel Tank Capacity:	litres (US gal)	218 (57.59)	
Fuel Consumption Prime	litres (US gal)/hr	19.4 (5.1)	
Fuel Consumption Standby	litres (US gal)/hr	21 (5.5)	

Engine Technical Data

No. of Cylinders	4		
Alignment	IN LINE		
Cycle	4 STROKE		
Bore	mm (in)	105 (4.1)	
Stroke	mm (in)	127 (5)	
Induction	TURBOCHARGED AIR TO AIR CHARGE COOLED		
Cooling Method	WATER		
Governing Type	ELECTRONIC		
Governing Class	ISO 8528 G2		
Compression Ratio	16.7:1		
Displacement	L (cu. in)	4.4 (268.4)	
Moment of Inertia:	kg m ² (lb/in ²)	1.324 (4524)	
Voltage	12		
Ground	Negative		
Battery Charger Amps	65		
Engine Weight Dry	kg (lb)	439 (968)	
Engine Weight Wet	kg (lb)	448 (988)	

Engine Performance Data

		50 Hz	60 Hz
Engine Speed	rpm	1500	
Gross Engine Power Prime	kW (hp)	78.2 (105)	
Gross Engine Power Standby	kW (hp)	85.7 (115)	
BMEP Prime	kPa (psi)	1422 (206.3)	
BMEP Standby	kPa (psi)	1559 (226.1)	



Fuel System

Fuel Filter Type:	Replaceable Element				
Recommended Fuel:	Class A2 Diesel				
Fuel Consumption at		110 % Load	100 % Load	75 % Load	50 % Load
50 Hz Prime:	l/hr (US gal/hr)	21 (5.5)	19.4 (5.1)	15.1 (4)	10.7 (2.8)
50 Hz Standby	l/hr (US gal/hr)	-	21 (5.5)	16.4 (4.3)	11.6 (3.1)
60 Hz Prime	l/hr (US gal/hr)				
60 Hz Standby	l/hr (US gal/hr)	-			

(Based on diesel fuel with a specific gravity of 0.83 and conforming to BS2869 classA2,EN590)

Air System

Air System		50 Hz	60 Hz
Air Filter Type:			Paper Element
Combustion Air Flow Prime	m ³ /min (cfm)	5.7 (201)	
Combustion Air Flow Standby	m ³ /min (cfm)	6 (213)	
Max. Combustion Air Intake Restriction	kPa	8 (32.1)	

Cooling System

Cooling System		50 Hz	60 Hz
Cooling System Capacity	l (US gal)	17.5 (4.6)	
Water Pump Type:			Centrifugal
Heat Rejected to Water & Lube Oil: Prime	kW (Btu/min)	50.3 (2861)	
Heat Rejected to Water & Lube Oil: Standby	kW (Btu/min)	55.4 (3151)	
Heat Radiation to Room*: Prime	kW (Btu/min)	21.6 (1228)	
Heat Radiation to Room*: Standby	kW (Btu/min)	23.7 (1348)	
Radiator Fan Load:	kW (hp)	2.8 (3.8)	
Radiator Cooling Airflow:	m ³ /min (cfm)	197.4 (6971)	
External Restriction to Cooling Airflow:	Pa (in H ₂ O)	125 (0.5)	

*: Heat radiated from engine and alternator
 Designed to operate in ambient conditions up to 50°C (122°F).
 Contact your local FG Wilson Dealer for power ratings at specific site conditions.

Lubrication System

Oil Filter Type:	Spin-on, Full flow		
Total Oil Capacity:	l (US gal)	8.4 (2.2)	
Oil Pan Capacity:	l (US gal)	6.9 (1.8)	
Oil Type:	API CH4 15W-40		
Oil Cooling Method:	WATER		

Exhaust System

Exhaust System		50 Hz	60 Hz
Maximum Allowable Back Pressure:	kPa (in Hg)	15 (4.4)	
Exhaust Gas Flow: Prime	m ³ /min (cfm)	13.8 (487)	
Exhaust Gas Flow: Standby	m ³ /min (cfm)	14.8 (523)	
Exhaust Gas Temperature: Prime	°C (°F)	470 (878)	
Exhaust Gas Temperature: Standby	°C (°F)	492 (918)	



Alternator Physical Data

No. of Bearings:	1
Insulation Class:	H
Winding Pitch:	2/3
Winding Code	M0
Wires:	12
Ingress Protection Rating:	IP23
Excitation System:	SHUNT
AVR Model:	Mark V

* dependant on voltage code selected

Alternator Operating Data

Overspeed: rpm	2250
Voltage Regulation: (Steady state) %	+/- 0.5
Wave Form NEMA = TIF:	50
Wave Form IEC = THF: %	2
Total Harmonic content LL/LN: %	2
Radio Interference:	EN 55011
Radiant Heat: 50 Hz kW (Btu/min)	7.6 (432)
Radiant Heat: 60 Hz kW (Btu/min)	

Alternator Performance Data 50 Hz:

		415/240 V	400/230 V	380/220 V	
Voltage Code					
Motor Starting Capability*	kVA	180	137	151	202
Short Circuit Capacity**	%	300	300	300	300
Reactances	Xd	2.88	3.1	3.43	2.56
	X'd	0.24	0.26	0.29	0.214
	X''d	0.099	0.099	0.11	0.082

Alternator Performance Data 60 Hz

Voltage Code					
Motor Starting Capability*	kVA	202	127	152	170
Short Circuit Capacity**	%	300	300	300	300
Reactances	Xd				
	X'd				
	X''d				

Reactances shown are applicable to prime ratings.

*Based on 30% voltage dip at 0.6 power factor.

** With optional independant excitation system (PMG / AUX winding)



Output Ratings 50 Hz

Voltage Code	kVA	Prime		Standby	
		kVA	kW	kVA	kW
415/240V	80	64	64	88	70.4
400/230V	80	64	64	88	70.4
380/220V	80	64	64	88	70.4
230/115V					
220/127V					
220/110V					
200/115V					
240V					
230V					
220V					

Output Ratings 60 Hz

Voltage Code	kVA	Prime		Standby	
		kVA	kW	kVA	kW
480/277V					
440/254V					
416/240V					
400/230V					
380/220V					
240/139V					
240/120V					
230/115V					
220/127V					
220/110V					
208/120V					
240/120					
220/110					

Sound Pressure Levels (dBA)

Generator Set Model		50 Hz						60 Hz					
		15 m (50 ft)		7 m (23 ft)		1 m (3 ft)		15 m (50 ft)		7 m (23 ft)		1 m (3 ft)	
		75% Load	100% Load	75% Load	100% Load	75% Load	100% Load	75% Load	100% Load	75% Load	100% Load	75% Load	100% Load
Three Phase													
P33-3	Prime	61	63	67	69	78	80	63	64	69	70	80	82
	Standby	62	64	68	70	79	81	63	65	69	71	81	82
P33-6	Prime	61	62	67	68	78	79	-	-	-	-	-	-
	Standby	61	63	67	69	78	80	-	-	-	-	-	-
P50-3	Prime	56	57	62	63	73	73	59	60	65	66	76	77
	Standby	56	58	62	64	73	74	59	61	65	67	76	78
P55-3	Prime	56	58	62	64	73	74	59	61	65	67	76	78
	Standby	57	58	63	64	73	75	60	62	66	68	77	79
P65-5	Prime	57	59	63	65	73	75	61	63	67	69	77	80
	Standby	57	59	63	65	74	76	61	64	67	70	78	81
P65-6	Prime	58	59	64	65	76	77	-	-	-	-	-	-
	Standby	58	60	64	66	76	78	-	-	-	-	-	-
P88-3	Prime	59	61	65	67	77	79	61	62	67	68	78	80
	Standby	60	62	66	68	78	80	61	63	67	69	79	81
P88-6	Prime	60	61	66	67	76	77	-	-	-	-	-	-
	Standby	60	61	66	67	77	77	-	-	-	-	-	-
P110-3	Prime	65	66	71	72	81	82	66	67	72	73	81	81
	Standby	66	66	72	72	81	82	66	67	72	73	81	82
P110-6	Prime	61	61	67	67	77	77	-	-	-	-	-	-
	Standby	61	61	67	67	77	77	-	-	-	-	-	-
P150-5	Prime	60	61	66	67	76	78	61	62	67	68	79	79
	Standby	60	61	66	67	77	78	61	62	67	68	79	79
P165-5	Prime	62	63	68	69	79	80	65	65	71	71	82	82
	Standby	62	63	68	69	79	80	65	65	71	71	82	82
P165-6	Prime	62	62	68	68	78	79	-	-	-	-	-	-
	Standby	62	63	68	69	78	79	-	-	-	-	-	-
P175-2	Prime	62	63	68	69	78	79	-	-	-	-	-	-
	Standby	63	63	69	69	79	79	-	-	-	-	-	-
P200-3	Prime	66	66	72	72	83	83	69	69	75	75	84	85
	Standby	66	66	72	72	83	83	69	69	75	75	84	85
P200-6	Prime	62	63	68	69	79	80	-	-	-	-	-	-
	Standby	62	63	68	69	79	80	-	-	-	-	-	-
P220-3	Prime	66	66	72	72	83	83	-	-	-	-	-	-
	Standby	66	67	72	73	83	83	-	-	-	-	-	-

Dimensions and Weights

Generator Set Model	A: mm (in)	B: mm (in)	C: mm (in)	D: mm (in)	E*: mm (in)		Weight: kg (lb)	Fuel Capacity: l
Three Phase								
P33-3	1864	898	1253	1349	880	–	846	56.0
P33-6	1864	898	1253	1349	880	–	846	56.0
P50-3	2291	1026	1426	–	800	1000	1025	145
P55-3	2291	1026	1426	–	800	1000	1025	145
P65-5	2291	1026	1426	–	800	1000	1067	145
P65-6	2291	1026	1426	–	800	1000	1107	145
P88-3	2291	1126	1527	–	1000	–	1202	188
P88-6	2761	1126	1535	–	1000	–	1401	212
P110-3	2761	1126	1535	–	1000	–	1402	212
P110-6	2761	1126	1535	–	1000	–	1402	212
P150-5	3515	1126	1681	–	1015	–	1754	289
P165-5	3515	1126	1681	–	1015	–	1892	289
P165-6	3515	1126	1681	–	1015	–	1937	289
P175-2	3515	1126	1681	–	1015	–	1937	289
P200-3	3515	1326	1681	–	1015	–	2074	384
P200-6	3515	1326	1681	–	1015	–	2134	384
P220-3	3515	1326	1681	–	1015	–	2159	384

*Clearance required both sides; Weight with lube oil, no coolant, no fuel.

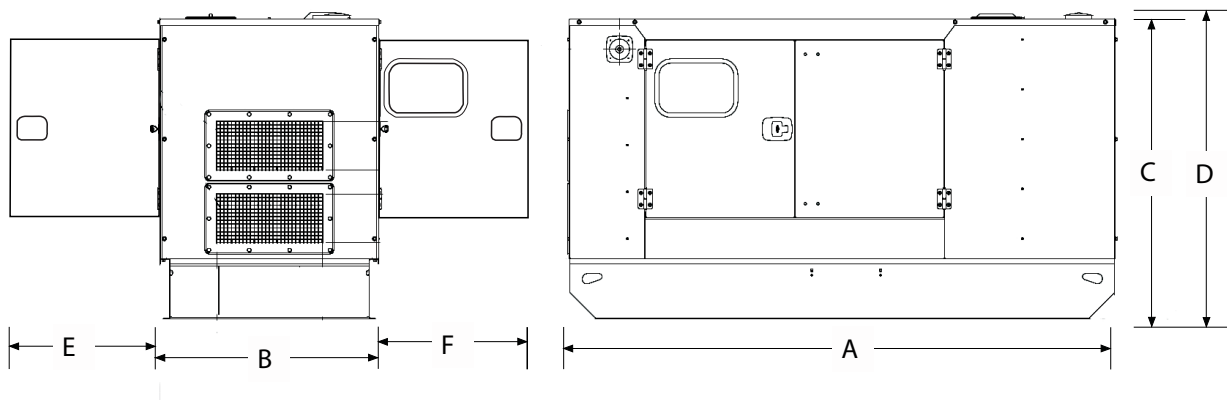

FG Wilson manufactures product in the following locations:

Northern Ireland • Brazil • China • India • USA

With headquarters in Northern Ireland, FG Wilson operates through a Global Dealer Network.

To contact your local Sales Office please visit the FG Wilson website at www.FGWilson.com.

FG Wilson is a trading name of Caterpillar (NI) Limited.

In line with our policy of continuous product development, we reserve the right to change specification without notice.

24-220kVAEnclosure/0816/GB