



An Oshkosh Corporation Company

Operation and Safety Manual

Original Instructions - Keep this manual with the machine at all times.

Model - 1230ES

ANSI



P/N - 3121221

August 15, 2013

FOREWORD

This manual is a very important tool! Keep it with the machine at all times.

The purpose of this manual is to provide owners, users, operators, lessors, and lessees with the precautions and operating procedures essential for the safe and proper machine operation for its intended purpose.

Due to continuous product improvements, JLG Industries, Inc. reserves the right to make specification changes without prior notification. Contact JLG Industries, Inc. for updated information.

NOTICE

IT IS A GOOD PRACTICE TO AVOID PRESSURE-WASHING ELECTRICAL/ELECTRONIC COMPONENTS. SHOULD PRESSURE-WASHING BE UTILIZED TO WASH AREAS CONTAINING ELECTRICAL/ELECTRONIC COMPONENTS, JLG INDUSTRIES, INC. RECOMMENDS A MAXIMUM PRESSURE OF 750 PSI (52 BAR) AT A MINIMUM DISTANCE OF 12 INCHES (30.5 CM) AWAY FROM THESE COMPONENTS. IF ELECTRICAL/ELECTRONIC COMPONENTS ARE SPRAYED, SPRAYING MUST NOT BE DIRECT AND BE FOR BRIEF TIME PERIODS TO AVOID HEAVY SATURATION.

SAFETY ALERT SYMBOLS AND SAFETY SIGNAL WORDS



This is the Safety Alert Symbol. It is used to alert you to the potential personal injury hazards. Obey all safety messages that follow this symbol to avoid possible injury or death

⚠ DANGER

INDICATES AN IMMINENTLY HAZARDOUS SITUATION. IF NOT AVOIDED, WILL RESULT IN SERIOUS INJURY OR DEATH. THIS DECAL WILL HAVE A RED BACKGROUND.

⚠ WARNING

INDICATES A POTENTIALITY HAZARDOUS SITUATION. IF NOT AVOIDED, COULD RESULT IN SERIOUS INJURY OR DEATH. THIS DECAL WILL HAVE AN ORANGE BACKGROUND.

⚠ CAUTION

INDICATES A POTENTIALITY HAZARDOUS SITUATION. IF NOT AVOIDED, MAY RESULT IN MINOR OR MODERATE INJURY. IT MAY ALSO ALERT AGAINST UNSAFE PRACTICES. THIS DECAL WILL HAVE A YELLOW BACKGROUND.

NOTICE

INDICATES INFORMATION OR A COMPANY POLICY THAT RELATES DIRECTLY OR INDIRECTLY TO THE SAFETY OF PERSONNEL OR PROTECTION OF PROPERTY.

⚠ WARNING

THIS PRODUCT MUST COMPLY WITH ALL SAFETY RELATED BULLETINS. CONTACT JLG INDUSTRIES, INC. OR THE LOCAL AUTHORIZED JLG REPRESENTATIVE FOR INFORMATION REGARDING SAFETY RELATED BULLETINS WHICH MAY HAVE BEEN ISSUED FOR THIS PRODUCT.

NOTICE

JLG INDUSTRIES, INC. SENDS SAFETY RELATED BULLETINS TO THE OWNER OF RECORD OF THIS MACHINE. CONTACT JLG INDUSTRIES, INC. TO ENSURE THAT THE CURRENT OWNER RECORDS ARE UPDATED AND ACCURATE.

NOTICE

JLG INDUSTRIES, INC. MUST BE NOTIFIED IMMEDIATELY IN ALL INSTANCES WHERE JLG PRODUCTS HAVE BEEN INVOLVED IN AN ACCIDENT INVOLVING BODILY INJURY OR DEATH OF PERSONNEL OR WHEN SUBSTANTIAL DAMAGE HAS OCCURRED TO PERSONAL PROPERTY OR THE JLG PRODUCT.

For :

- Accident Reporting
- Product Safety Publications
- Current Owner Updates
- Questions Regarding Product Safety
- Standards and Regulations Compliance Information
- Questions Regarding Special Product Applications
- Questions Regarding Product Modifications

Contact :

Product Safety and Reliability Department
JLG Industries, Inc.
13224 Fountainhead Plaza
Hagerstown, MD 21742

or Your Local JLG Office
(See addresses on manual rear cover)

In USA:

Toll Free: 877-JLG-SAFE (877-554-7233)

Outside USA:

Phone: 240-420-2661
E-mail: ProductSafety@JLG.com

REVISION LOG

Original Issue of Manual November 4, 2005
Manual Revised..... May 8, 2006
Manual Revised..... July 13, 2006
Manual Revised..... January 23, 2007
Manual Revised..... March 19, 2007
Manual Revised..... May 16, 2007
Manual Revised..... June 11, 2007
Manual Revised..... May 6, 2008
Manual Revised..... June 22, 2010
Manual Revised..... August 15, 2013

SECTION - PARAGRAPH, SUBJECT	PAGE
FOREWORD	A
SAFETY ALERT SYMBOLS AND SAFETY SIGNAL WORDS	B
Contact :	C
In USA:	C
Outside USA:	C
REVISION LOG	D
 SECTION - 1 - SAFETY PRECAUTIONS	
1.1 GENERAL	1-1
1.2 PRE-OPERATION	1-2
Operator Training and Knowledge	1-2
Workplace Inspection	1-2
Machine Inspection	1-3
1.3 OPERATION	1-4
General	1-4
Trip and Fall Hazards	1-5
Electrocution Hazards	1-6
Tipping Hazards	1-8
Crushing and Collision Hazards	1-9
1.4 TOWING, LIFTING, AND HAULING	1-10

SECTION - PARAGRAPH, SUBJECT	PAGE
 SECTION - 2 - USER RESPONSIBILITIES, MACHINE PREPARATION AND INSPECTION	
2.1 PERSONNEL TRAINING	2-1
Operator Training	2-1
Training Supervision	2-2
Operator Responsibility	2-2
2.2 PREPARATION, INSPECTION, AND MAINTENANCE	2-2
2.3 PRE-START INSPECTION	2-4
2.4 FUNCTION CHECK	2-5
2.5 DAILY WALK-AROUND INSPECTION	2-7
 SECTION - 3 - MACHINE CONTROLS AND INDICATORS	
3.1 GENERAL	3-1
3.2 CONTROLS AND INDICATORS	3-2
Ground Control Station	3-3
Battery Charger/Hour Meter Indicators	3-5
Platform Control Station	3-8
Platform Control and Indicator Panel	3-9
Drive/Lift/Steer Joystick Control	3-10
3.3 DECAL INSTALLATION	3-12

TABLE OF CONTENTS

SECTION - PARAGRAPH, SUBJECT	PAGE	SECTION - PARAGRAPH, SUBJECT	PAGE
SECTION - 4 - MACHINE OPERATION			
4.1 DESCRIPTION	4-1	Mechanical Brake Release	4-19
4.2 OPERATING CHARACTERISTICS AND LIMITATIONS	4-1	SECTION - 5 - EMERGENCY PROCEDURES	
General	4-1	5.1 GENERAL INFORMATION	5-1
Placards	4-1	5.2 EMERGENCY OPERATION	5-1
4.3 PLATFORM LOADING	4-1	Operator Unable to Control Machine	5-1
4.4 BATTERY CHARGING	4-2	Platform Caught Overhead	5-1
Battery Charger Fault Codes	4-3	5.3 PLATFORM MANUAL DESCENT	5-1
4.5 AC INVERTER OPERATION (OPTION)	4-4	5.4 INCIDENT NOTIFICATION	5-2
4.6 OPERATION	4-6	SECTION - 6 - GENERAL SPECIFICATIONS AND OPERATOR MAINTENANCE	
Platform/Ground Select Switch	4-6	6.1 INTRODUCTION	6-1
Emergency Stop Switch	4-6	Other Publications Available Specific to this Machine:	6-1
4.7 RAISING AND LOWERING PLATFORM	4-7	6.2 OPERATING SPECIFICATIONS	6-2
Raising Platform	4-8	Platform Capacities	6-3
Lowering Platform	4-10	Dimensional Data	6-3
4.8 STEERING AND TRAVELING	4-12	Tires	6-4
Steering	4-12	Batteries	6-4
Driving Forward and Reverse	4-13	6.3 CRITICAL STABILITY WEIGHTS	6-4
4.9 PARKING AND STOWING MACHINE	4-15	6.4 LUBRICATION	6-5
4.10 TIE DOWN/LIFT LUGS	4-16	Lubrication Capacities	6-5
Tie Down	4-16	Hydraulic Oil	6-5
Lifting	4-16	Lubrication Specifications	6-6
4.11 TOWING	4-18		
Electric Brake Release	4-18		

SECTION - PARAGRAPH, SUBJECT	PAGE
6.5 OPERATOR MAINTENANCE	6-7
Oil Check Procedure	6-7
6.6 BATTERY MAINTENANCE.....	6-8
Battery Maintenance and Safety Practices	6-8
6.7 TIRES AND WHEELS.....	6-9
Tire Wear and Damage	6-9
Wheel and Tire Replacement	6-9
Wheel Installation	6-9
6.8 SUPPLEMENTAL INFORMATION	6-10
6.9 DIAGNOSTIC TROUBLE CODES (DTC)	6-11
6.10 DTC CHECK TABLE INDEX	6-11
6.1 DIAGNOSTIC TROUBLE CODES (DTC) CHECK TABLES	6-12
0-0 Help Comments	6-12
2-1 Power-Up	6-14
2-2 Platform Controls.....	6-14
2-3 Ground Controls.....	6-16
2-5 Function Prevented.....	6-16
3-1 Line Contactor Open Circuit.....	6-18
3-2 Line Contactor Short Circuit.....	6-19
3-3 Ground Output Driver	6-19
4-2 Thermal Limit (SOA)	6-22
4-4 Battery Supply.....	6-22
6-6 Communication	6-23
6-7 Accessory	6-24
7-7 Electric Motor	6-24

SECTION - PARAGRAPH, SUBJECT	PAGE
8-1 Tilt Sensor	6-25
8-2 Platform Load Sense	6-26
9-9 Hardware.....	6-26

SECTION - 7 - INSPECTION AND REPAIR LOG

LIST OF FIGURES

2-1. Daily Walk-Around Inspection.....	2-8
3-1. Location of Machine Controls.....	3-2
3-2. Ground Control Station	3-3
3-3. Ground Controls.....	3-4
3-4. Battery Charger and Hour Meter Indicators	3-5
3-5. Location of Manual Descent Valve (Front of Machine)	3-6
3-6. Location of Brake Release Switch (Rear of Machine)	3-7
3-7. Platform Control Station.....	3-8
3-8. Platform Control/Indicator Panel	3-9
3-9. Platform Control Components	3-10
3-10. 1230ES - Decal Installation.....	3-12
4-1. Location of Battery Charger AC Input Plug.....	4-2
4-2. Location of AC Inverter ON/OFF - Toggle Switch	4-4
4-3. Platform/Ground Select Switch.....	4-6

TABLE OF CONTENTS

SECTION - PARAGRAPH, SUBJECT	PAGE
4-4. Ground Control - Emergency Stop Switch	4-6
4-5. Platform Control - Emergency Stop Switch	4-7
4-6. Raising Platform From Ground Control	4-8
4-7. Raising Platform From Platform Control	4-9
4-8. Lowering Platform From Ground Control	4-10
4-9. Lowering Platform From Platform Control	4-11
4-10. Steering from Platform Control	4-12
4-11. Driving Forward from Platform Control	4-13
4-12. Grade and Slideslope Definition	4-14
4-13. Securing Control Station to Platform	4-15
4-14. Tie Down and Lift Lug Locations	4-16
4-15. Lifting Using Spreader Bar	4-17
4-16. Electric Brake Release	4-18
4-17. Brake - Manual Disengage	4-19
5-1. Location of Manual Descent Valve (Front of Machine)	5-2
6-1. Hydraulic Oil Check Procedure	6-7
6-2. Battery Fluid Level	6-8
6-3. Wheel Lug Nut Tightening Sequence	6-9

SECTION - PARAGRAPH, SUBJECT	PAGE
LIST OF TABLES	
1-1 Minimum Approach Distances (M.A.D.)	1-6
2-1 Inspection and Maintenance Table	2-3
2-2 Tilt Cutout Settings	2-6
3-1 1230ES - (ANSI and CE) Decal Installation Chart	3-13
4-1 Battery Charger Fault Codes	4-3
6-1 Operating Specification	6-2
6-2 Capacities	6-3
6-3 Dimensions	6-3
6-4 Tire Specifications	6-4
6-5 Battery Specifications	6-4
6-6 Critical Stability Weights	6-4
6-7 Capacities	6-5
6-8 Hydraulic Oil	6-5
6-9 Lubrication Specifications	6-6
6-10 Hydraulic Oil Specifications (OEM)	6-6
6-11 Wheel Torque Chart	6-10
7-1 Inspection and Repair Log	7-1

SECTION 1. SAFETY PRECAUTIONS

1.1 GENERAL

This section outlines the necessary precautions for proper and safe machine usage and maintenance. In order to promote proper machine usage, it is mandatory that a daily routine is established based on the content of this manual. A maintenance program, using the information provided in this manual and the Service and Maintenance Manual, must also be established by a qualified person and must be followed to ensure that the machine is safe to operate.

The owner/user/operator/lessor/lessee of the machine should not accept operating responsibility until this manual has been read, training is accomplished, and operation of the machine has been completed under the supervision of an experienced and qualified operator.

These sections contain the responsibilities of the owner, user, operator, lessor, and lessee concerning safety, training, inspection, maintenance, application, and operation. If there are any questions with regard to safety, training, inspection, maintenance, application, and operation, please contact JLG Industries, Inc. ("JLG").

WARNING

FAILURE TO COMPLY WITH THE SAFETY PRECAUTIONS LISTED IN THIS MANUAL COULD RESULT IN MACHINE DAMAGE, PROPERTY DAMAGE, PERSONAL INJURY OR DEATH.

1.2 PRE-OPERATION

Operator Training and Knowledge

- The Operators and Safety Manual must be read in its entirety before operating the machine. For clarification, questions, or additional information regarding any portions of this manual, contact JLG Industries, Inc.

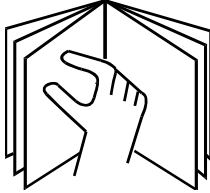

- An operator must not accept operating responsibilities until adequate training has been given by competent and authorized persons.
- Allow only those authorized and qualified personnel to operate the machine who have demonstrated that they understand the safe and proper operation and maintenance of the unit.
- Read, understand, and obey all DANGERS, WARNINGS, CAUTIONS, and operating instructions on the machine and in this manual.

- Ensure that the machine is to be used in a manner which is within the scope of its intended application as determined by JLG.
- All operating personnel must be familiar with the emergency controls and emergency operation of the machine as specified in this manual.
- Read, understand, and obey all applicable employer, local, and governmental regulations as they pertain to your utilization and application of the machine.

Workplace Inspection

- Precautions to avoid all hazards in the work area must be taken by the user before operation of the machine.
- Do not operate or raise the platform from a position on trucks, trailers, railway cars, floating vessels, scaffolds or other equipment unless the application is approved in writing by JLG.
- Before operation, check work area for overhead hazards such as electric lines, bridge cranes, and other potential overhead obstructions.
- Check floor surfaces for holes, bumps, drop-offs, obstructions, debris, concealed holes, and other potential hazards.
- Check the work area for hazardous locations. Do not operate the machine in hazardous environments unless approved for that purpose by JLG.

- Ensure that the ground conditions are adequate to support the maximum tire load indicated on the tire load decals located on the chassis adjacent to each wheel.
- Do not operate the machine when wind conditions exceed 28 mph (ANSI/CSA SPEC) / (CE/AUST SPEC) - Indoor Use Only.
- This machine can be operated in nominal ambient temperatures of 0° F to 104° F (-20° C to 40° C). Consult JLG to optimize operation outside of this temperature range.
- Do not operate any machine on which the safety or instruction placards or decals are missing or illegible.
- Check the machine for modifications to original components. Ensure that any modifications have been approved by JLG.
- Avoid accumulation of debris on platform deck. Keep mud, oil, grease, and other slippery substances from footwear and platform deck.

Machine Inspection

- Do not operate this machine until the inspections and functional checks have been performed as specified in Section 2 of this manual.
- Do not operate this machine until it has been serviced and maintained according to the maintenance and inspection requirements as specified in the machine's Service and Maintenance Manual.
- Ensure all safety devices are operating properly. Modification of these devices is a safety violation.

WARNING

MODIFICATION OR ALTERATION OF AN AERIAL WORK PLATFORM SHALL BE MADE ONLY WITH PRIOR WRITTEN PERMISSION FROM THE MANUFACTURER

1.3 OPERATION

General

- Do not use the machine for any purpose other than positioning personnel, their tools, and equipment.
- Before operation, the user must be familiar with the machine capabilities and operating characteristics of all functions.
- Never operate a malfunctioning machine. If a malfunction occurs, shut down the machine. Remove the unit from service and notify the proper authorities.
- Do not remove, modify, or disable any safety devices.
- Never slam a control switch or lever through neutral to an opposite direction. Always return switch to neutral and stop before moving the switch to the next function. Operate controls with slow and even pressure.
- Hydraulic cylinders, other than the outrigger cylinders, should never be left at end of travel (fully extended or fully retracted) before shutdown or for long periods of time. Always “bump” control in opposite direction slightly when function reaches end of travel. This applies both to machines in operation or in the stowed position.
- Do not allow personnel to tamper with or operate the machine from the ground with personnel in the platform, except in an emergency.
- Do not carry materials directly on platform railing unless approved by JLG.
- When two or more persons are in the platform, the operator shall be responsible for all machine operations.
- Always ensure that power tools are properly stowed and never left hanging by their cord from the platform work area.
- Do not assist a stuck or disabled machine by pushing or pulling except by pulling at the chassis tie-down lugs.
- Stow platform assembly and shut off all power before leaving machine.

Trip and Fall Hazards

- JLG Industries, Inc. recommends that all persons in the platform wear a full body harness with a lanyard attached to an authorized lanyard anchorage point while operating this machine. For further information regarding fall protection requirements on JLG products, contact JLG Industries, Inc.

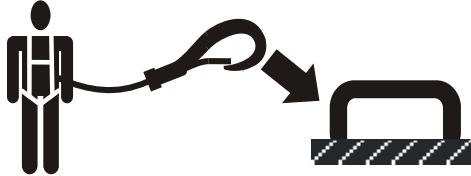

- Prior to operation, ensure all gates and rails are fastened and secured in their proper position. Identify the designated lanyard anchorage point(s) at the platform and securely attach the lanyard. Attach only one (1) lanyard per lanyard anchorage point
- Use extreme caution when entering or leaving platform. Ensure that the platform assembly is fully lowered. Face the machine when entering or leaving the platform. Always maintain “three point contact” with the machine, using two hands and one foot or two feet and one hand at all times during entry and exit.

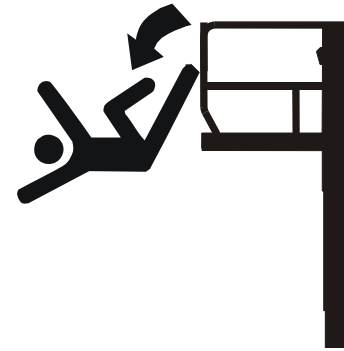

- Keep both feet firmly positioned on the platform floor at all times. Never position ladders, boxes, steps, planks, or similar items on unit to provide additional reach for any purpose.
- Keep oil, mud, and slippery substances cleaned from footwear and the platform floor.

Electrocution Hazards

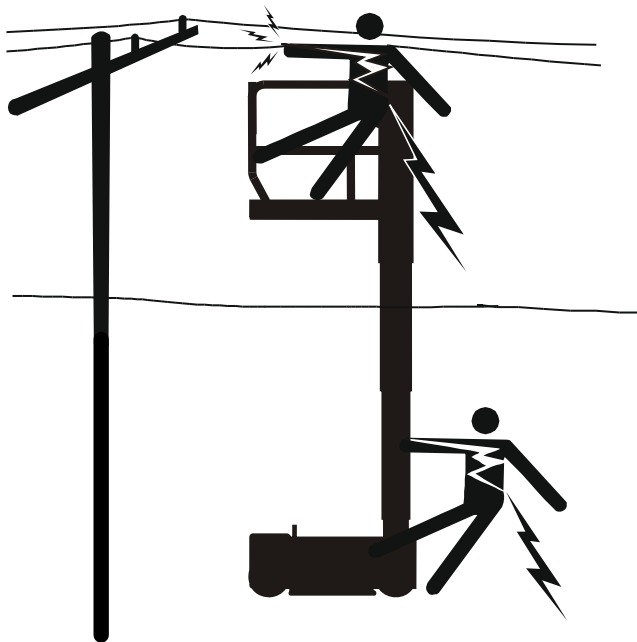

- This machine is not insulated and does not provide protection from contact or proximity to electrical current.
- Maintain distance from electrical lines, apparatus, or any energized (exposed or insulated) parts according to the Minimum Approach Distance (MAD) as shown in Table 1-1.
- Allow for machine movement and electrical line swaying.

Table 1-1. Minimum Approach Distances (M.A.D.)

Voltage Range (Phase to Phase)	MINIMUM APPROACH DISTANCE in Feet (Meters)
0 to 50 KV	10 (3)
Over 50KV to 200 KV	15 (5)
Over 200 KV to 350 KV	20 (6)
Over 350 KV to 500 KV	25 (8)
Over 500 KV to 750 KV	35 (11)
Over 750 KV to 1000 KV	45 (14)

NOTE: This requirement shall apply except where employer, local or governmental regulations are more stringent.

- Maintain a clearance of at least 10 ft. (3m) between any part of the machine and its occupants, their tools, and their equipment from any electrical line or apparatus carrying up

to 50,000 volts. One foot additional clearance is required for every additional 30,000 volts or less.

- The minimum approach distance may be reduced if insulating barriers are installed to prevent contact, and the barriers are rated for the voltage of the line being guarded. These barriers shall not be part of (or attached to) the machine. The minimum approach distance shall be reduced to a distance within the designed working dimensions of the insulating barrier. This determination shall be made by a qualified person in accordance with the employer, local, or governmental requirements for work practices near energized equipment



DO NOT MANEUVER MACHINE OR PERSONNEL INSIDE PROHIBITED ZONE (MAD). ASSUME ALL ELECTRICAL PARTS AND WIRING ARE ENERGIZED UNLESS KNOWN OTHERWISE.

Tipping Hazards

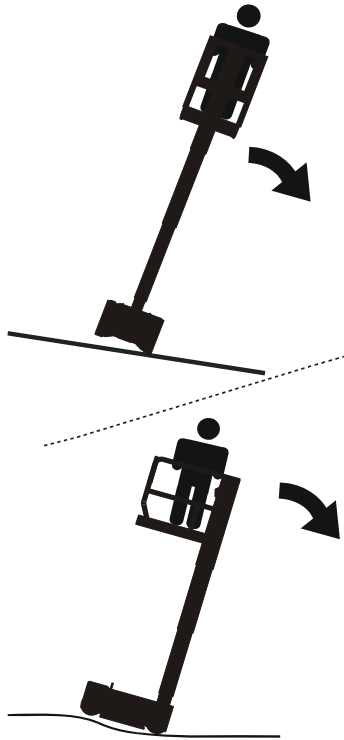

- Ensure that the ground conditions are adequate to support the maximum tire load indicated on the tire load decals located on the chassis adjacent to each wheel. Do not travel on unsupported surfaces.
- The user should be familiar with the driving surface before driving. Do not exceed the allowable sideslope and grade while driving.
- Do not elevate platform or drive with platform elevated while on or near a sloping, uneven, or soft surface. Ensure machine is positioned on a firm, level and smooth surface before elevating platform or driving with the platform in the elevated position.
- Before driving on floors, bridges, trucks, and other surfaces, check allowable capacity of the surfaces.
- Never exceed the maximum work load as specified on the platform. Keep all loads within the confines of the platform, unless authorized by JLG.
- Keep the chassis of the machine a minimum of 2 ft. (0.6m) from holes, bumps, drop-offs, obstructions, debris, concealed holes, and other potential hazards at the ground level.
- Never attempt to use the machine as a crane. Do not tie-off machine to any adjacent structure. Never attach wire, cable, or any similar items to platform.

- Do not cover the platform sides or carry large surface-area items in the platform when operating outdoors. The addition of such items increases the exposed wind area of the machine.
- Do not increase the platform size with unauthorized deck extensions or attachments.
- If mast assembly or platform is caught so that one or more wheels are off the ground, all persons must be removed before attempting to free the machine. Use cranes, forklift trucks, or other appropriate equipment to stabilize machine and remove personnel.

Crushing and Collision Hazards

- Approved head gear must be worn by all operating and ground personnel.
- Keep hands and limbs off of the mast assembly during operation.
- Watch for obstructions around machine and overhead when driving. Check clearances above, on sides, and bottom of platform when lifting or lowering platform.

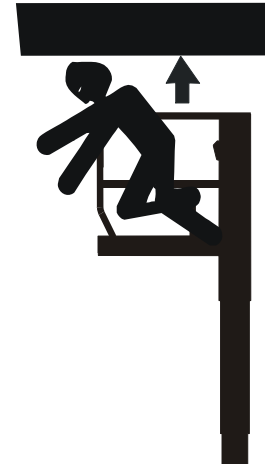

SECTION 1 - SAFETY PRECAUTIONS

- During operation, keep all body parts inside platform railing.
 - Always post a lookout when driving in areas where vision is obstructed.
 - Keep non-operating personnel at least 6 ft. (1.8m) away from machine during all driving operations.
 - Under all travel conditions, the operator must limit travel speed according to conditions of ground surface, congestion, visibility, slope, location of personnel, and other factors causing hazards of collision or injury to personnel.
 - Be aware of stopping distances in all drive speeds. When driving in high speed, switch to low speed before stopping. Travel grades in low speed only.
 - Do not use high speed drive in restricted or close quarters or when driving in reverse.
 - Exercise extreme caution at all times to prevent obstacles from striking or interfering with operating controls and persons in the platform.
 - Ensure that operators of other overhead and floor level machines are aware of the aerial work platform's presence. Disconnect power to overhead cranes. Barricade floor area if necessary.
- Avoid operating over ground personnel. Warn personnel not to work, stand, or walk under a raised platform. Position barricades on floor as necessary.

1.4 TOWING, LIFTING, AND HAULING

- Never allow personnel in platform while towing, lifting, or hauling.
- This machine should not be towed, except in the event of emergency, malfunction, power failure, or loading/unloading. Refer to emergency towing procedures.
- Ensure platform is fully retracted and completely empty of tools prior to towing, lifting or hauling.
- When lifting machine with a forklift, position forks only at designated areas of the machine. Lift with a forklift of adequate capacity.
- Refer to Section 4 for lifting information.

SECTION 2. USER RESPONSIBILITIES, MACHINE PREPARATION AND INSPECTION

2.1 PERSONNEL TRAINING

The aerial platform is a personnel handling device; so it is necessary that it be operated and maintained only by trained personnel.

Persons under the influence of drugs or alcohol or who are subject to seizures, dizziness or loss of physical control must not operate this machine.

Operator Training

Operator training must cover:

- 1.** Use and limitations of the controls in the platform and at the ground, emergency controls and safety systems.
- 2.** Control labels, instructions, and warnings on the machine.
- 3.** Rules of the employer and government regulations.
- 4.** Use of approved fall protection equipment.
- 5.** Enough knowledge of the mechanical operation of the machine to recognize a malfunction or potential malfunction.
- 6.** The safest means to operate the machine where overhead obstructions, other moving equipment, and obstacles, depressions, holes, drop-offs.
- 7.** Means to avoid the hazards of unprotected electrical conductors.
- 8.** Specific job requirements or machine application.

Training Supervision

Training must be done under the supervision of a qualified person in an open area free of obstructions until the trainee has developed the ability to safely control and operate the machine.

Operator Responsibility

The operator must be instructed that he/she has the responsibility and authority to shut down the machine in case of a malfunction or other unsafe condition of either the machine or the job site.

2.2 PREPARATION, INSPECTION, AND MAINTENANCE

Table 2-1 covers the periodic machine inspections and maintenance recommended by JLG Industries, Inc. Consult local regulations for further requirements for aerial work platforms. The frequency of inspections and maintenance must be increased as necessary when the machine is used in a harsh or hostile environment, if the machine is used with increased frequency, or if the machine is used in a severe manner.

SECTION 2 - USER RESPONSIBILITIES, MACHINE PREPARATION AND INSPECTION

Table 2-1. Inspection and Maintenance Table

Type	Frequency	Primary Responsibility	Service Qualification	Reference
Pre-Start Inspection	Before using each day; or whenever there's an Operator change.	User or Operator	User or Operator	Operator and Safety Manual
Pre-Delivery Inspection <i>(see note below)</i>	Before each sale, lease, or rental delivery.	Owner, Dealer, or User	Qualified JLG Mechanic	Service and Maintenance Manual and applicable JLG inspection form
Frequent Inspection	In service for 3 months or 150 hours, whichever comes first; or Out of service for a period of more than 3 months; or Purchased used.	Owner, Dealer, or User	Qualified JLG Mechanic	Service and Maintenance Manual and applicable JLG inspection form
Annual Machine Inspection <i>(see note below)</i>	Annually, no later than 13 months from the date of prior inspection.	Owner, Dealer, or User	Factory Trained Service Technician (Recommended)	Service and Maintenance Manual and applicable JLG inspection form
Preventative Maintenance	At intervals as specified in the Service and Maintenance Manual.	Owner, Dealer, or User	Qualified JLG Mechanic	Service and Maintenance Manual

NOTE: Inspection forms are available from JLG. Use the Service and Maintenance Manual to perform inspections.

NOTICE

JLG INDUSTRIES, INC. RECOGNIZES A FACTORY-CERTIFIED SERVICE TECHNICIAN AS A PERSON WHO HAS SUCCESSFULLY COMPLETED THE JLG SERVICE TRAINING SCHOOL FOR THE SPECIFIC JLG PRODUCT MODEL.

SECTION 2 - USER RESPONSIBILITIES, MACHINE PREPARATION AND INSPECTION

2.3 PRE-START INSPECTION

The Pre-Start Inspection should include each of the following:

1. **Cleanliness** – Check all surfaces for leakage (oil or battery fluid) or foreign objects. Report any leakage to the proper maintenance personnel.
2. **Structure** - Inspect the machine structure for dents, damage, weld or parent metal cracks or other discrepancies.

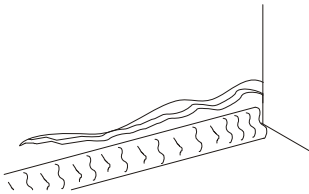

Parent Metal Crack

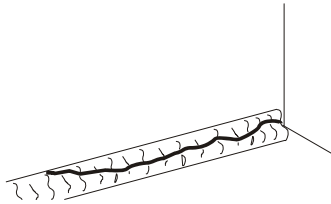

Weld Crack

3. **Decals and Placards** – Check all for cleanliness and legibility. Make sure none of the decals and placards are missing. Make sure all illegible decals and placards are cleaned or replaced.
4. **Operators and Safety Manuals** - Check that a copy of the Operator and Safety Manual is enclosed in the weather resistant storage container.
5. **“Walk-Around” Inspection** – Refer to Figure 2-1. on page 2-8.
6. **Battery** – Charge as required.
7. **Fluid Levels** - Check the hydraulic oil level in the pump reservoir.
8. **Accessories/Attachments** - Reference the Operator and Safety Manual of each attachment or accessory installed upon the machine for specific inspection, operation, and maintenance instructions.
9. **Function Check** – Once the “Walk-Around” Inspection is complete, perform a functional check of all systems in an area free of overhead and ground level obstructions. Refer to Section 4 for more specific instructions on the operation of each function.

2.4 FUNCTION CHECK

Perform the Function Check as follows:

1. From the **Ground Control Panel** with no load in the platform:
 - a. Check if the platform/off/ground selector switch and the platform lift-up/lift-down switch operate properly.
 - b. Check that Pot-Hole-Protection system operates properly, platform raised - bars down, platform down - bars up.

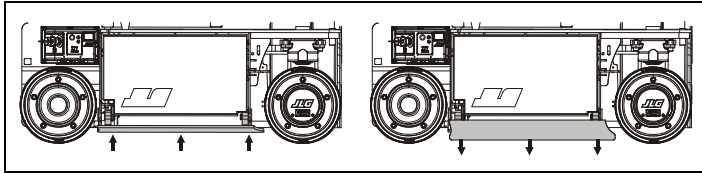

- c. Ensure that all machine functions are disabled when the Emergency Stop Button is depressed.
 - d. With platform raised a few feet (meters), check if the manual descent valve (*located at the base of the mast on the front of the machine*), lowers the platform properly.

2. From the **Platform Control Console**:

- a. Ensure that the control console is firmly secured in the proper location.
- b. Check that all guards protecting switches are in place.
- c. Operate all functions, drive/lift mode select switch, horn button, enable trigger, and joystick functions to ensure proper operation.
- d. With the platform elevated 6 in. (15cm) or more on a smooth, firm, and level surface, drive the machine to check if the high drive cutout speed-limit is engaged. Drive speed will be reduced from a top speed of 3mph (4.8 kph) to 0.5 mph (0.8 kph)
- e. Ensure that all machine functions are disabled when the Emergency Stop Button depressed.

SECTION 2 - USER RESPONSIBILITIES, MACHINE PREPARATION AND INSPECTION

3. With the platform in the transport (stowed) position.
 - a. Drive the machine on a grade, not to exceed the rated gradeability, and stop to ensure the brakes hold.
 - b. Check the tilt indicator light/alarm to ensure proper operation. The light/alarm should be activated when tilted at or beyond the values in Table 2-2.

NOTE: *When the tilt indicator warning is activated the following functions are affected;*

ANSI/CSA/AUS Spec. - *Drive and Lift functions are disabled, platform must be lowered (stowed) to drive out of tilt condition.*

CE Spec. - *Drive and Lift function are NOT disabled.*

Table 2-2. Tilt Cutout Settings

1230ES	Tilt Setting (front to back)	Tilt Setting (side to side)
ANSI/CSA	3°	1.5°
CE/AUS	3.4°	3.4°

2.5 DAILY WALK-AROUND INSPECTION

Begin the “Walk-Around Inspection” at Item 1, see Figure 2-1. on page 2-8. Continue checking each item in sequence for the conditions listed in the following checklist.

WARNING

**TO AVOID POSSIBLE INJURY, BE SURE MACHINE POWER IS “OFF”.
DO NOT OPERATE UNTIL ALL MALFUNCTIONS HAVE BEEN CORRECTED.**

NOTICE

DO NOT OVERLOOK VISUAL INSPECTION OF CHASSIS UNDERSIDE. CHECKING THIS AREA OFTEN RESULTS IN DISCOVERY OF CONDITIONS WHICH COULD CAUSE EXTENSIVE MACHINE DAMAGE.

INSPECTION NOTE: On all components, make sure there are no loose or missing parts, that they are securely fastened, and that no visible damage, leaks or excessive wear exists in addition to any other criteria mentioned.

1. Platform Control Console - Placard secure and legible, control lever and switches return to neutral, and emergency stop switch function properly, manual in storage box.

2. Front Wheel - Drive motor, steer linkage, and steer cylinder - (*open side access door*) - *See Inspection Note*
3. Wheels and Tires - Properly secured, no missing lug nuts. Refer to Section 6.1, TIRES AND WHEELS. Inspect wheels for damage and corrosion.
4. Pothole Protection System - *See Inspection Note*
5. Battery Compartment - *See Inspection Note.*
6. Manual Descent - *See Inspection Note*
7. Beacon - *See Inspection Note*
8. Ground Controls - Placard secure and legible, control switches return to neutral position, emergency stop switch functions properly. Control markings legible.
9. Hydraulic Pump/Motor, Control Valve Installation - No unsupported wires or hoses; no damaged or broken wires - *See Inspection Note*
10. Mast Assembly - *See Inspection Note*
11. Platform/Handrail/Gate Installation (*Not Shown*) - *See Inspection Note*

SECTION 2 - USER RESPONSIBILITIES, MACHINE PREPARATION AND INSPECTION

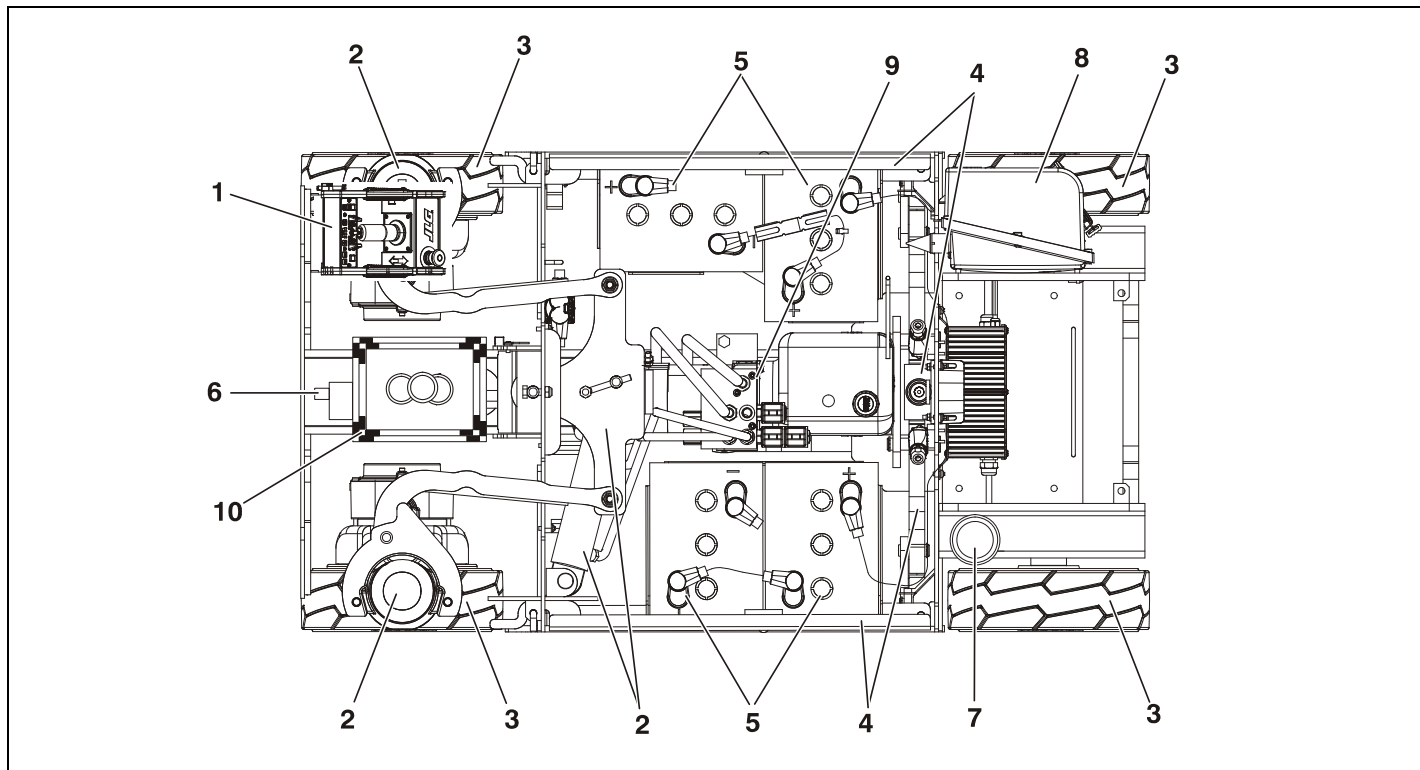

Figure 2-1. Daily Walk-Around Inspection (Shown Top View Cutaway).

SECTION 3. MACHINE CONTROLS AND INDICATORS

3.1 GENERAL

This section provides the necessary information needed to understand controls and their functions.

NOTICE

THE MANUFACTURER HAS NO DIRECT CONTROL OVER MACHINE APPLICATION AND OPERATION, THE USER AND OPERATOR ARE RESPONSIBLE FOR CONFORMING WITH GOOD SAFETY PRACTICES.

3.2 CONTROLS AND INDICATORS

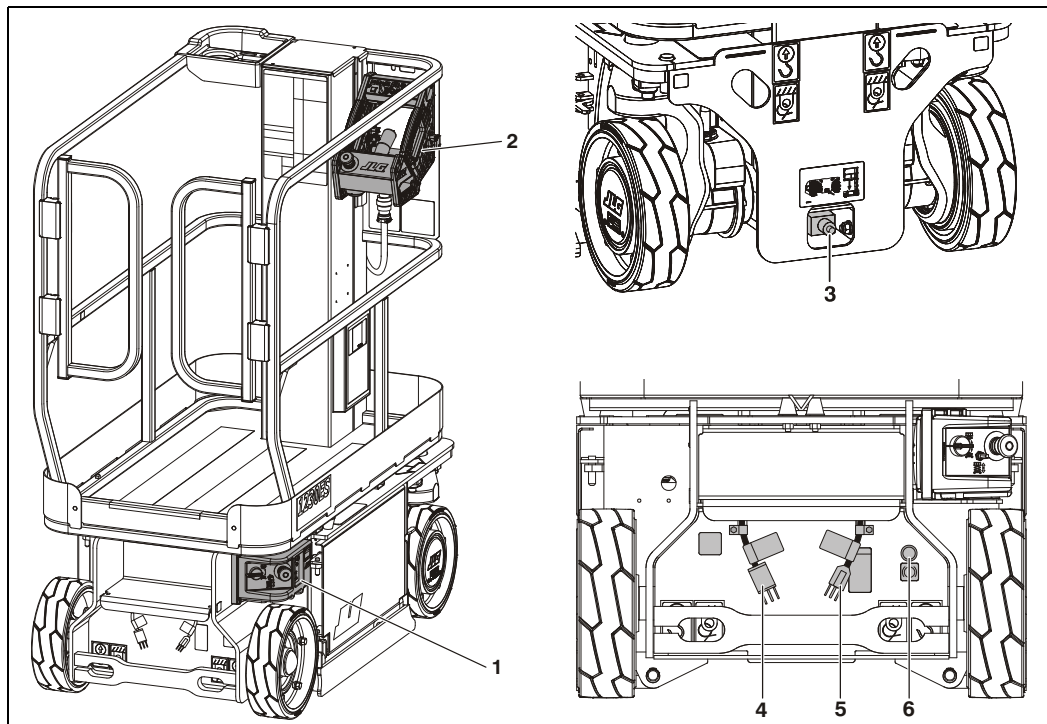

1. Ground Control Station
2. Platform Control Station
3. Platform Manual Descent Valve
4. *AC Plug - To Platform AC Receptacle Outlet Box
5. AC Plug - Battery Charger Input Plug
6. Brake Release Button

* When equipped with the inverter/charger option, the AC plug (4) to the platform AC receptacle box outlet will be eliminated from the rear panel. The platform AC receptacle box outlet will be plugged directly into the inverter/charger internally. Also an inverter ON/STANDBY toggle switch will be mounted on the rear panel.

Figure 3-1. Location of Machine Controls.

Ground Control Station

⚠ WARNING

DO NOT OPERATE FROM GROUND CONTROL STATION WITH PERSONNEL IN THE PLATFORM EXCEPT IN AN EMERGENCY.

TO AVOID SERIOUS INJURY, DO NOT OPERATE MACHINE IF PLATFORM LIFT/LOWER SWITCH DOES NOT RETURN TO THE OFF OR NEUTRAL POSITION WHEN RELEASED.

PERFORM AS MANY PRE-OPERATIONAL CHECKS AND INSPECTIONS FROM THE GROUND CONTROL STATION AS POSSIBLE.

NOTICE

WHEN THE MACHINE IS SHUT DOWN FOR OVERNIGHT PARKING OR BATTERY CHARGING, THE EMERGENCY STOP AND POWER SELECT SWITCHES MUST BE POSITIONED TO OFF TO PREVENT DRAINING THE BATTERIES.

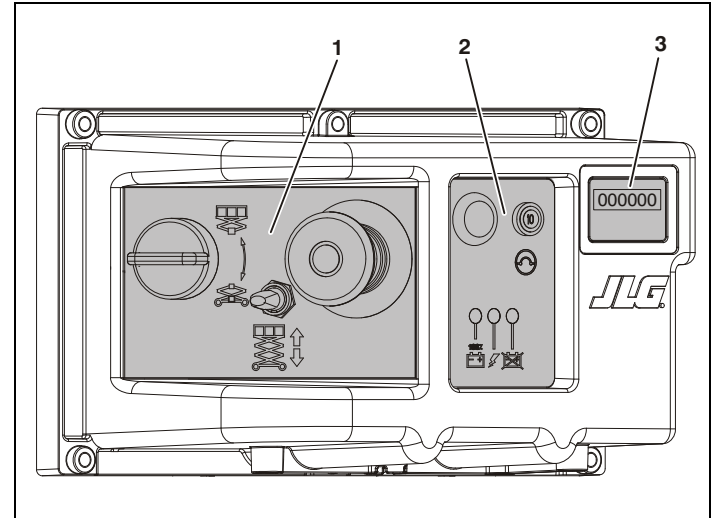

Figure 3-2. Ground Control Station

1. Ground Controls
2. Battery Charging - Status Indicators and Circuit Breaker
3. Hour Meter

Ground Controls

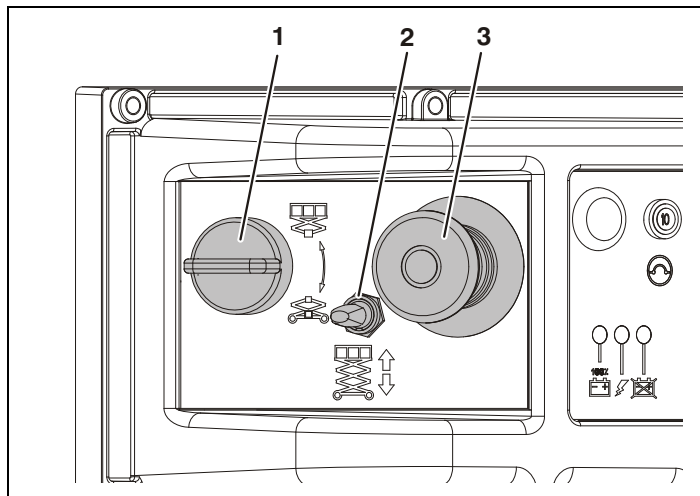





Figure 3-3. Ground Controls

1. Platform/Off/Ground Selector Switch
2. Platform Lift/Lower Switch
3. Emergency Stop Switch

1. **Platform/Off/Ground Selector Switch** - A three position, key-operated power select switch supplies operating power to the platform or ground controls and powers machine down in the off position.
2. **Platform Lift/Lower Switch** - A three position, momentary contact lift control switch provides raising and lowering of the platform when positioned to up or down.
3. **Emergency Stop Switch** - A two-position, red, mushroom-shaped emergency stop switch, when positioned to ON with the power selector switch positioned to ground, furnishes operating power to the ground control station. In addition, the switch can be used to turn off power to the function controls in the event of an emergency. Power is turned on by pulling the switch out, and is turned off by depressing switch.

Battery Charger/Hour Meter Indicators

- Battery Charger Status** - This panel, located to the right of the ground control box, is designed to give the operator an accurate read on the status of the battery charger.

 <p>100%</p>	GREEN - Charge Complete
	YELLOW - Charging in Process
	RED - Charging Abnormal

- 10 Amp Circuit Breaker** - This circuit breaker protects the Ground Control Station in case of a short circuit or other malfunction in the ground controls circuit.
- Hour Meter** - The hour meter shows the total amount of lift operation time accumulated.

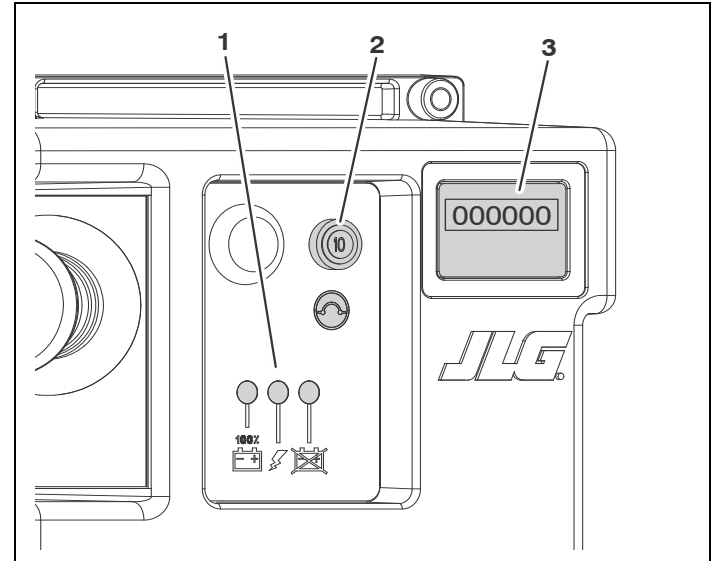

Figure 3-4. Battery Charger and Hour Meter Indicators

- Battery Charging Status - GREEN/YELLOW/RED Indicators
- 10 Amp Circuit Breaker
- Hour Meter

Platform Manual Descent Valve

The platform manual descent valve is used in the event of total power failure to retract and lower the platform using gravity. The manual descent valve is located at the bottom of the mast assembly on the front of the machine inside an access hole. Look for the instruction decal located just above the access hole.

The procedure is as follows:

1. Locate the **manual descent valve (1)** on the front of the machine at the base of the mast.

⚠ WARNING

KEEP HANDS AND ARMS OUT OF THE PATH OF THE MAST AND PLATFORM WHILE LOWERING.

2. Press and hold the RED button on the manual descent valve, release the button when the platform is lowered to desired level.

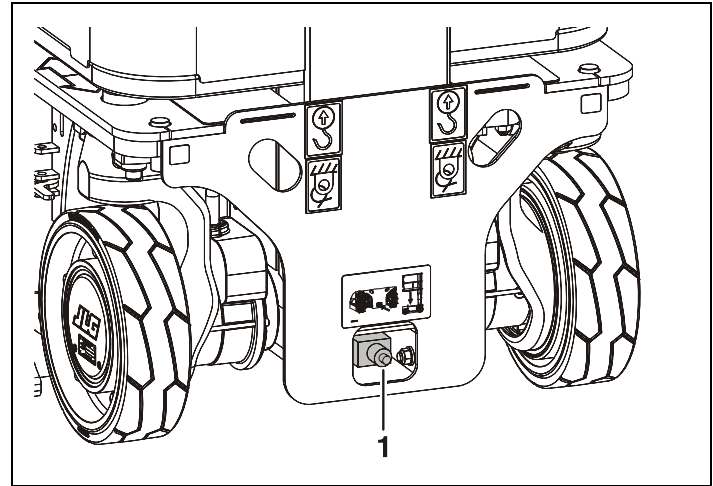

**Figure 3-5. Location of Manual Descent Valve
(Front of Machine)**

Brake Release Switch

NOTE: If the machine's batteries are completely depleted of electrical charge the brakes cannot be released electrically. The brakes must be released mechanically, see "Mechanical Brake Release" on page 4-19.

⚠ WARNING

DO NOT MANUALLY DISENGAGE THE BRAKES UNLESS THE MACHINE IS SETTING ON A LEVEL SURFACE OR THE MACHINE IS FULLY RESTRAINED.

1. The **brake release switch (1)** is located on the **lower rear panel (2)** on the machine.
2. The machine must be powered ON to GROUND CONTROL MODE at the Platform/Off/Ground Selector Switch on the **Ground Control Station (3)** to operate the brake release switch.

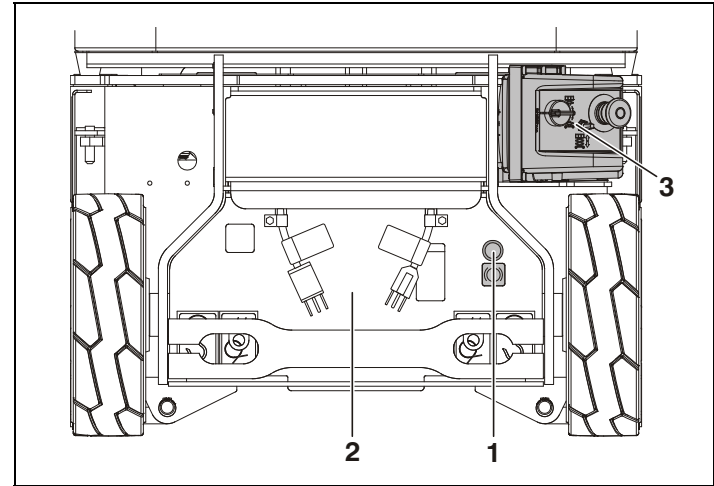
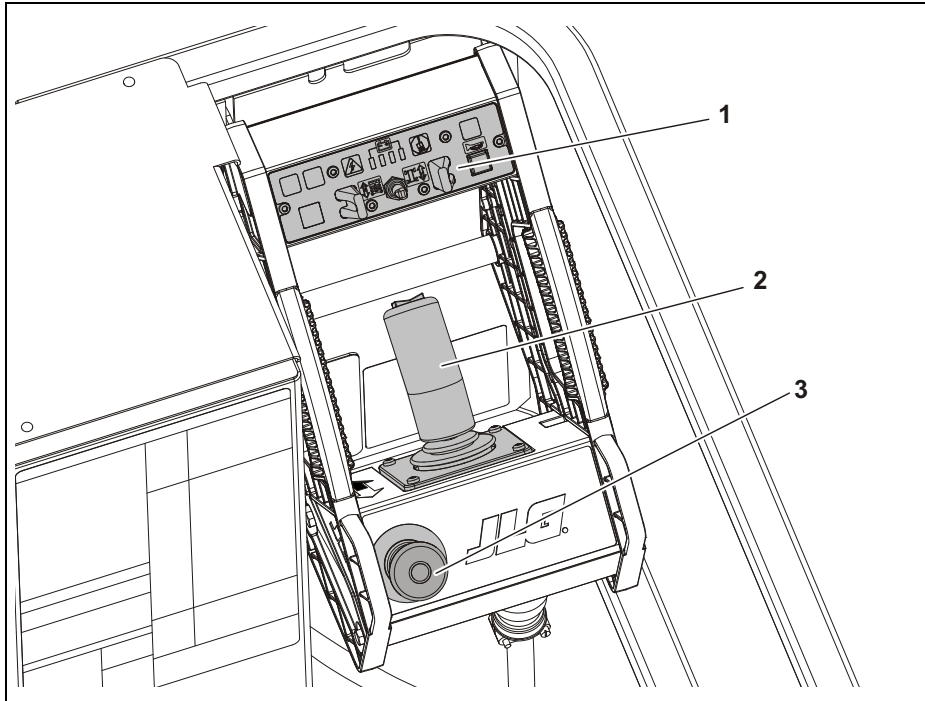

Figure 3-6. Location of Brake Release Switch (Rear of Machine)

Platform Control Station



- 1. Platform Control and Indicator Panel
- 2. Drive/Lift/Steer Joystick Control
- 3. Emergency Stop Switch

Figure 3-7. Platform Control Station.

Platform Control and Indicator Panel

NOTE: The platform control and indicator panel uses different shaped symbols to alert the operator to different types of operational situations that could arise. The meaning of those symbols are explained below.



Tilt Indicator Warning Light - Indicates a potentially hazardous situation, which if not corrected, could result in serious injury or death. This indicator will be red.



System Distress Indicator - Indicates an abnormal operating condition, which if not corrected, may result in machine interruption or damage. This indicator will be yellow. *(SEE NOTE BELOW)

NOTE: * This lamp when activated is flashing a DTC (Diagnostic Troubleshooting Code). For an explanation of these codes and items the Operator can or cannot correct, see Section 6, GENERAL SPECIFICATIONS AND OPERATOR MAINTENANCE, sub-Section 6.1, DIAGNOSTIC TROUBLE CODES (DTC).

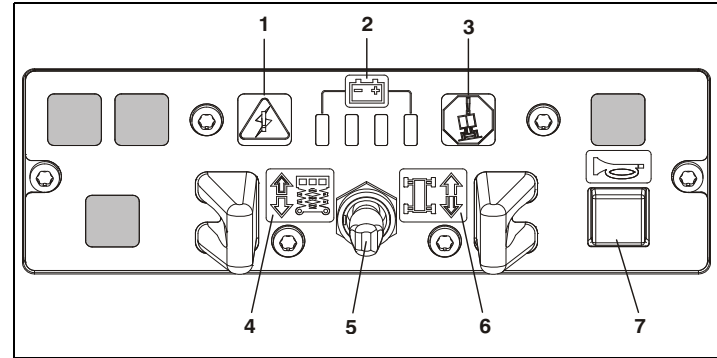

Figure 3-8. Platform Control/Indicator Panel

- | | |
|--------------------------------------|--------------------------------|
| 1. System Distress Indicator | 5. Lift or Drive Select Switch |
| 2. Battery Discharge Indicator (BDI) | 6. Drive Mode Indicator |
| 3. Tilt Indicator Warning Light | 7. Horn Button |
| 4. Platform Lift Mode Indicator | |

NOTE: The button and indicators shown shaded on the indicator panel are currently not used on the 1230ES machine.

! WARNING

TO AVOID SERIOUS INJURY, DO NOT OPERATE MACHINE IF ANY CONTROL LEVERS OR TOGGLE SWITCHES CONTROLLING ANY MACHINE FUNCTIONS DO NOT RETURN TO THE OFF OR NEUTRAL POSITION WHEN RELEASED.

SECTION 3 - MACHINE CONTROLS AND INDICATORS

1. **System Distress Indicator** - This indicator will light up with a fault flash code that indicate where a problem within the system exists.
2. **Battery Discharge Indicator (BDI)** - This set of lights is designed to let the operator know the condition of the batteries.
3. **Tilt Indicator Warning Light and Alarm** - A red warning light on the control panel illuminates and an audible alarm sounds when the chassis is at or beyond the permitted amount of slope.

⚠ WARNING

IF THE TILT INDICATOR WARNING LIGHT/ALARM IS ACTIVATED WHEN PLATFORM IS RAISED LOWER PLATFORM AND DRIVE TO A FIRM LEVEL SURFACE.

4. **5. 6. Lift/Drive Select** - This toggle switch is used to select either drive or lift. After selecting a function, the controller must be moved in the proper direction in order to activate that function. This function must be selected with the joystick in the neutral position. Otherwise, the function select will not occur.
7. **Horn** - This push-button switch, when activated, permits the operator to warn job-site personnel when the machine is operating in the area.

Drive/Lift/Steer Joystick Control

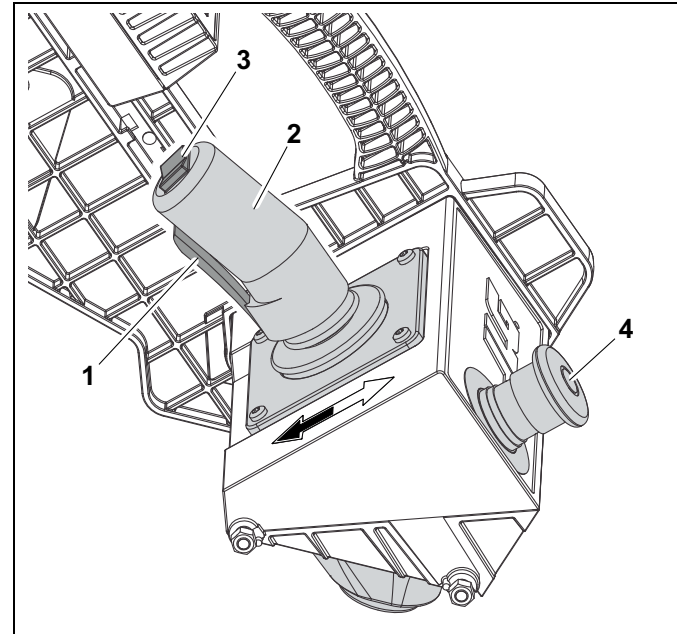
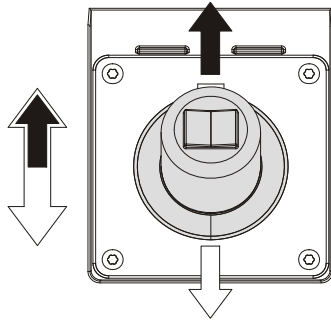

Figure 3-9. Platform Control Components

- | | |
|------------------------|--------------------------|
| 1. Trigger Switch | 3. Steer Switch |
| 2. Joystick Controller | 4. Emergency Stop Switch |

1. **Trigger Switch** - This switch is located on the front of the joystick controller. The trigger switch acts as an enable and must be depressed before operating the drive, steer and lift functions. When released, the function being operated will stop.
2. **Joystick Controller** - The control handle controls three functions: drive, lift, and steer.



Drive - The drive function must be selected using the drive/lift selector switch (*items 5 and 6 on the Platform Control/Indicator panel - Figure 3-8.*), prior to moving the control handle. After selecting the drive function, engage the trigger switch lever, then move the control handle forward to drive the machine forward or move the control handle backwards to drive the machine backward.

Lift - After selecting the lift function using the drive/lift selector switch (*item 4 and 5 on the Platform Control/Indicator panel - Figure 3-8.*), engage the trigger switch lever, moving the control handle backward to raise the platform and moving the control handle forward will lower the platform.

The speed on all selected functions is proportionally controlled by the distance of travel of the hand controller from the center position.

Steer - The thumb-operated steer switch on top of the control handle activates the steer wheels in the direction activated (right or left).

3. **Steer Switch** - The steer switch is a thumb operated switch located at the top of the control handle. Depressing the switch to the right will steer the wheels to the right. Depressing the switch to the left will steer the wheels to the left.
4. **Emergency Stop Switch** - A two-position, red, mushroom-shaped emergency stop switch functions to provide power to the platform control station and also to turn off power to the platform function controls in the event of an emergency. With the Power selector switch positioned to platform, power is turned on by pulling the switch out (on), and is turned off by pushing the switch in (off).

3.3 DECAL INSTALLATION

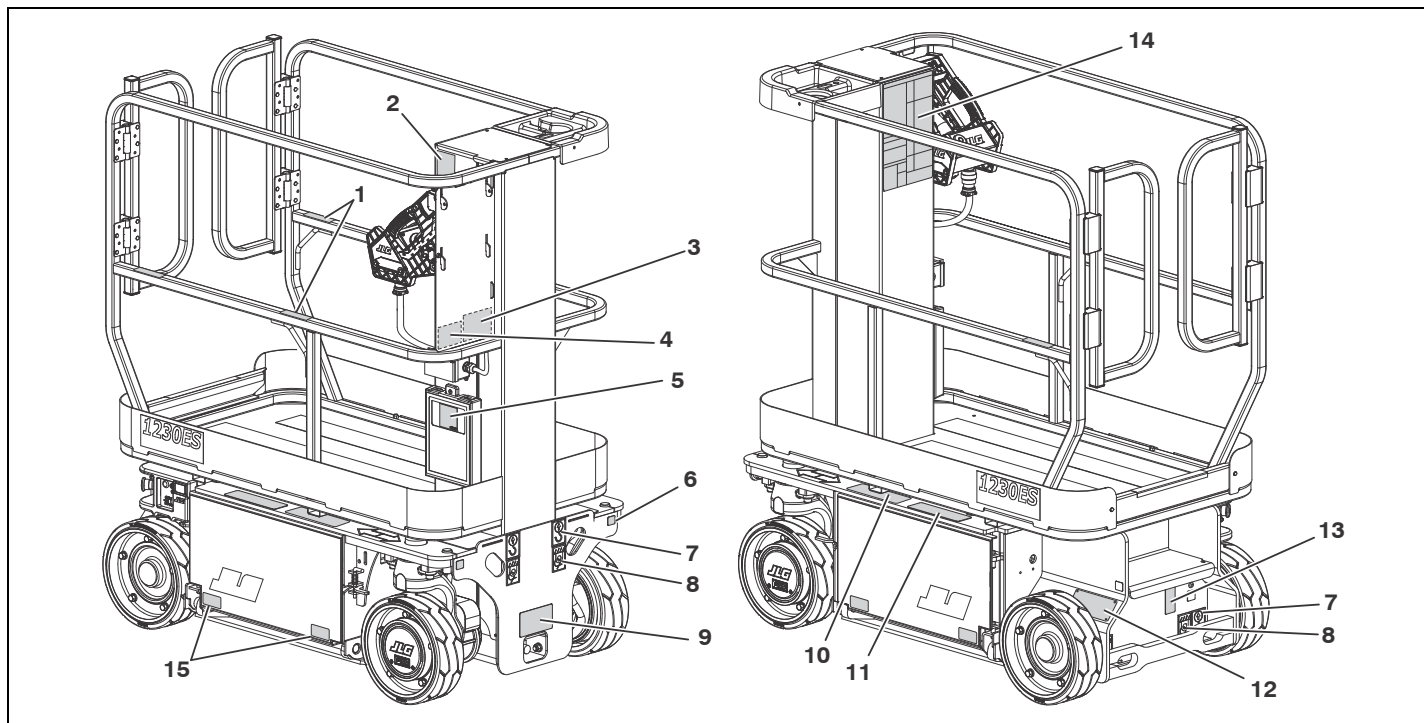

Figure 3-10. 1230ES - Decal Installation.

Table 3-1. 1230ES - (ANSI and CE) Decal Installation Chart (See Figure 3-10.)

ITEM	ANSI/ CSA	ANSI (LAT)	ANSI (BRZ)	ANSI (JPN)	ANSI (CHI)	CE/AUS	CSA (FRE)
1*	1704277	1704277	1704277	1704277	1704277	1704277	1704277
2	1705686	1705720	1705726	—	1705946	—	1705686
3	1700584	1700584	1700584	1700584	1700584	1700584	1700584
4	1702631	1702631	1702631	1702631	1702631	1702631	1702631
5	1701640	1701640	1701640	1701640	1701640	1701640	1701640
6*	1706671	1706671	1706671	1706671	1706671	1706671	1706671
7*	1703811	1703811	1703811	1703811	1703811	1703811	1703811
8*	1703814	1703814	1703814	1703814	1703814	1703814	1703814
9	1706670	1706670	1706670	1706670	1706670	1706670	1706670
10*	1706832	1705724	1706833	—	1705944	1706078	1706832
11*	1703786	1704032	1704024	1705099	1704081	1705099	1703786
12	1001096010	1001096010	1001096010	1001096010	1001096010	1706856 3252811 ⁽¹⁾	1001096010
13	1703785	1704031	1704023	1705803	1704079	1705803	1703785
14	1706676	1706682	1706684	1706686	1706683	1706686	1706681
15*	1704016	1704016	1704016	1704016	1704016	1704016	1704016

* Identical item mounted on opposite side of the machine.

NOTE: (1) Australia Only

SECTION 3 - MACHINE CONTROLS AND INDICATORS



NOTES:

<hr/>	<hr/>
<hr/>	<hr/>
<hr/>	<hr/>
<hr/>	<hr/>
<hr/>	<hr/>
<hr/>	<hr/>
<hr/>	<hr/>
<hr/>	<hr/>
<hr/>	<hr/>
<hr/>	<hr/>
<hr/>	<hr/>
<hr/>	<hr/>
<hr/>	<hr/>
<hr/>	<hr/>
<hr/>	<hr/>
<hr/>	<hr/>
<hr/>	<hr/>
<hr/>	<hr/>
<hr/>	<hr/>
<hr/>	<hr/>
<hr/>	<hr/>
<hr/>	<hr/>

SECTION 4. MACHINE OPERATION

4.1 DESCRIPTION

This machine is a self-propelled aerial work platform on top of an elevating mast mechanism. The Lift's intended purpose is to position personnel with their tools and supplies at positions above ground level. The machine can be used to reach work areas located above machinery or equipment positioned at ground level.

This JLG Lift has a primary operator Control Station in the platform. From this Control Station, the operator can drive and steer the machine in both forward and reverse directions, raise and lower the platform. The machine is also equipped with a Ground Control Station which will override the Platform Control Station. Ground Controls operate lift up, down and emergency stop. Ground Controls are to be used only in an emergency to lower the platform to the ground should the operator in the platform be unable to do so.

4.2 OPERATING CHARACTERISTICS AND LIMITATIONS

General

A thorough knowledge of the operating characteristics and limitations of the machine is always the first requirement for any user, regardless of user's experience with similar types of equipment.

Placards

Important points to remember during operation are provided at the control stations by DANGER, WARNING, CAUTION, IMPORTANT, NOTICE, and INSTRUCTION placards. This information is placed at various locations for the express purpose of alerting personnel of potential hazards constituted by the operating characteristics and limitations of the machine. See foreword for definitions of placard safety signal words.

4.3 PLATFORM LOADING

The platform maximum rated load capacity is shown on a placard located on the platform and is based upon the machine positioned on a smooth, firm, and level surface. Refer to Section 6 specifications for the maximum platform capacity.

The platform is entered through the gates at the rear of the machine. The gates push inward when entering.

NOTE: *Australian machines include a gate latch on both entry gates, press down on the latch release handles to open the gates, release handles to latch gates when closed.*

NOTE: *It is important to remember that the load should be evenly distributed on the platform. The load should be placed near the center of the platform when possible.*

SECTION 4 - MACHINE OPERATION

4.4 BATTERY CHARGING

NOTE: Be sure that machine is parked in a well ventilated area before charging begins.



ONLY PLUG THE CHARGER INTO A PROPERLY INSTALLED AND GROUNDED OUTLET. DO NOT USE GROUND ADAPTORS OR MODIFY PLUG. DO NOT TOUCH NON-INSULATED PORTION OF OUTPUT CONNECTOR OR NON-INSULATED BATTERY TERMINAL.

DO NOT OPERATE CHARGER IF THE AC SUPPLY CORD IS DAMAGED OR IF THE CHARGER HAS RECEIVED A SHARP BLOW, BEEN DROPPED, OR OTHERWISE DAMAGED IN ANY WAY.

ALWAYS DISCONNECT THE AC SUPPLY BEFORE MAKING OR BREAKING THE (POS/NEG) CONNECTIONS TO THE BATTERY.

DO NOT OPEN OR DISASSEMBLE CHARGER.

1. The battery charger **AC input plug (1)** is located on the panel at the **lower rear of the machine (2)** just behind the tie-down bar.
2. Connect the charger **AC input plug (1)** to a grounded outlet using a 3 wire 12 AWG extension cord. (Maximum charger current draw is 12A RMA @ 108 VAC.)

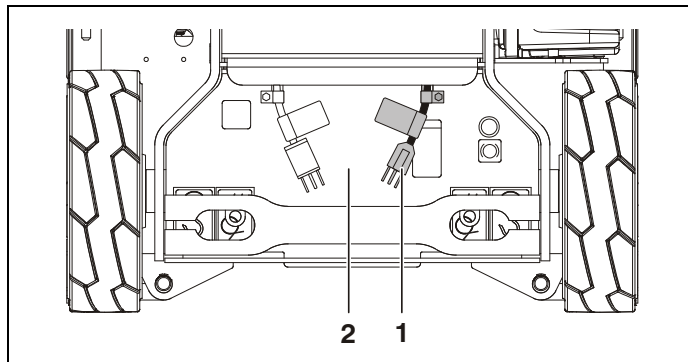

Figure 4-1. Location of Battery Charger AC Input Plug

3. When powered up the charger will go through a short LED indicator self-test. The battery charger light's on the Ground Control Station will flash in sequence for two seconds.
4. The batteries are fully charged when the green light on the battery charger status panel (Ground Control Station) is illuminated.

NOTE: If the charger is left plugged in, the charger will automatically restart a complete charge cycle if the batteries voltage drops below a minimum voltage or 30 days has elapsed.

Battery Charger Fault Codes

If a fault occurred during charging, the red "Fault" LED (*located on the Ground Control Station panel*) will flash with a code corresponding to the error. Refer to the table following for the flash codes and their removal.

If required, further general and troubleshooting information about the battery charger can be found in the charger manufacturer's Owner's Guide included in the manual storage box mounted on the machine.

Table 4-1. Battery Charger Fault Codes

FLASH(s)	FAULT	MODE(S) AFFECTED	REMEDY
1	High battery voltage	Invert or Charge	Discharge battery, unit will auto start.
2	Low battery voltage	Invert or Charge	Connect qualified external AC to charge batteries.
3	Charge time is greater than 20 hrs.	Charge	Remove DC loads or replace batteries.
4	Shorted battery	Charge	Replace Battery.
5	Over-temperature	Invert	Turn the toggle switch to Standby and allow inverter/charger to cool.
6	Over load Over current	Invert or Charge	Remove excessive AC loads and reset unit by turning the toggle switch to Standby they ON.

SECTION 4 - MACHINE OPERATION

4.5 AC INVERTER OPERATION (OPTION)

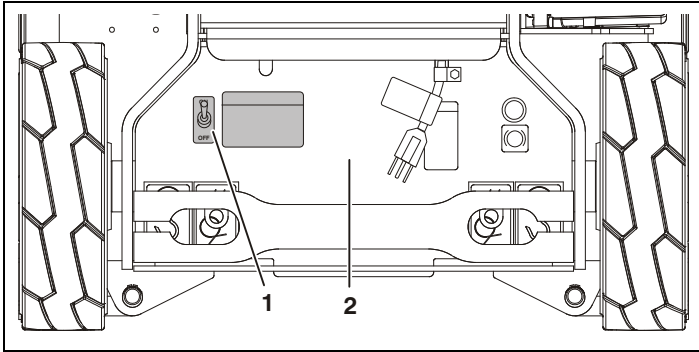

Figure 4-2. Location of AC Inverter ON/OFF - Toggle Switch

NOTE: The inverter automatically turns to OFF if it has not detected any AC loads for 2 hours, or if the loads are so small the unit cannot detect them, such as a cell phone charger. To continue inverter operation after an automatic shut-down, cycle the inverter ON/OFF toggle switch to OFF then back to ON.

1. The AC inverter ON/OFF **toggle switch (1)** is located on the **lower rear panel (2)** of the machine.
2. When the toggle switch is set to the ON position this will allow AC current from the inverter to flow to the AC receptacle box in the platform.

NOTE: Connect devices one at a time to the AC receptacle box. Do not connect to many high-surge devices at once.

3. To turn off the AC current to the platform AC receptacle box, set the inverter toggle switch to the OFF position.

NOTE: Further General and Troubleshooting information about the Inverter/Charger can be found in the manufacturers Owner's Guide included in the manual storage box mounted on the machine.



NOTES:

A large area for notes, consisting of two columns of horizontal lines. The left column has 15 lines and the right column has 15 lines, providing a total of 30 lines for handwritten notes.

4.6 OPERATION

Platform/Ground Select Switch

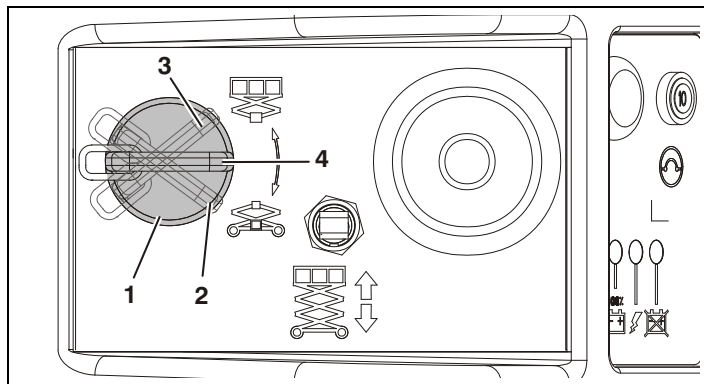

Figure 4-3. Platform/Ground Select Switch

The **power selector switch (1)** on the **Ground Control Station** functions to direct electrical power to the desired control station. With the switch in the **ground position (2)**, power is supplied to the emergency stop switch at the ground control station. When the switch is in the **platform position (3)**, power is supplied to the emergency stop switch at the platform control station. The switch should be in the **off position (4)** when parking the machine overnight.

Emergency Stop Switch

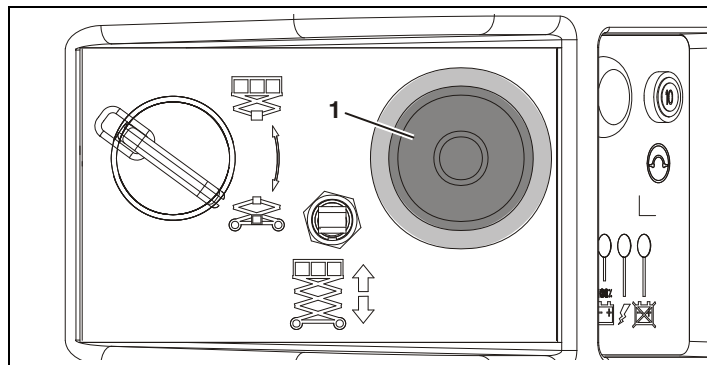

Figure 4-4. Ground Control - Emergency Stop Switch

This **emergency stop switch (1)**, when in the on (out) position, provides electrical power to the ground controls or platform controls, as applicable. In addition, the switch can be used to turn off power (push the switch IN) to the function controls in the event of an emergency.

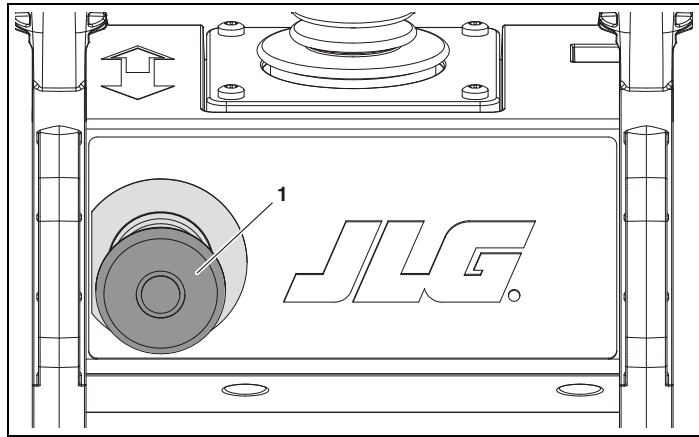

Figure 4-5. Platform Control - Emergency Stop Switch

The platform **emergency stop switch (1)**, when in the on (out) position, provides electrical power to the platform controls. Push the switch (in) to turn off power to the platform function controls in the event of an emergency.

4.7 RAISING AND LOWERING PLATFORM

⚠ WARNING

DO NOT RAISE PLATFORM EXCEPT ON A SMOOTH, FIRM AND LEVEL SURFACE FREE OF OBSTRUCTIONS AND HOLES.

TO AVOID SERIOUS INJURY, DO NOT OPERATE MACHINE IF ANY CONTROL LEVERS OR TOGGLE SWITCHES CONTROLLING PLATFORM MOVEMENT DOES NOT RETURN TO THE OFF OR NEUTRAL POSITION WHEN RELEASED.

IF THE PLATFORM DOES NOT STOP WHEN A CONTROL SWITCH OR LEVER IS RELEASED, USE THE EMERGENCY STOP SWITCH TO STOP THE MACHINE.

NOTE: *On the platform controller, when selecting between the Lift/Drive functions the joystick controller must be in the neutral position for 3 seconds before the function change is effective. The machine is inoperable before this time.*

Raising Platform

1. If the machine is shut down, place the platform/ground select switch to the desired position (*platform or ground*).
2. Position both the ground control station and platform control station emergency stop switches to the on position.

From Ground Control Station

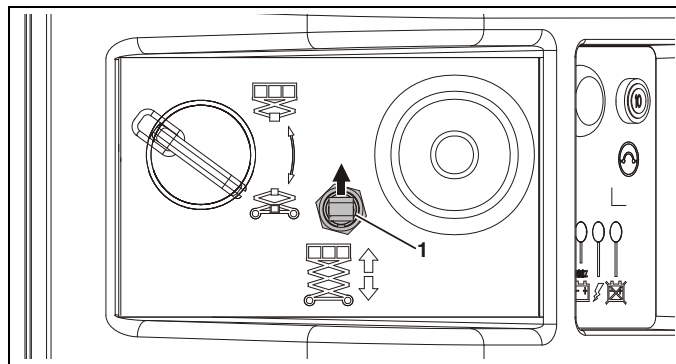

Figure 4-6. Raising Platform From Ground Control

1. **If operating from the ground controls -**
Position the **lift switch (1)** to up and hold until desired elevation is achieved.

⚠ WARNING

DO NOT OPERATE FROM GROUND CONTROL STATION WITH PERSONNEL IN THE PLATFORM EXCEPT IN AN EMERGENCY.

From Platform Control Station

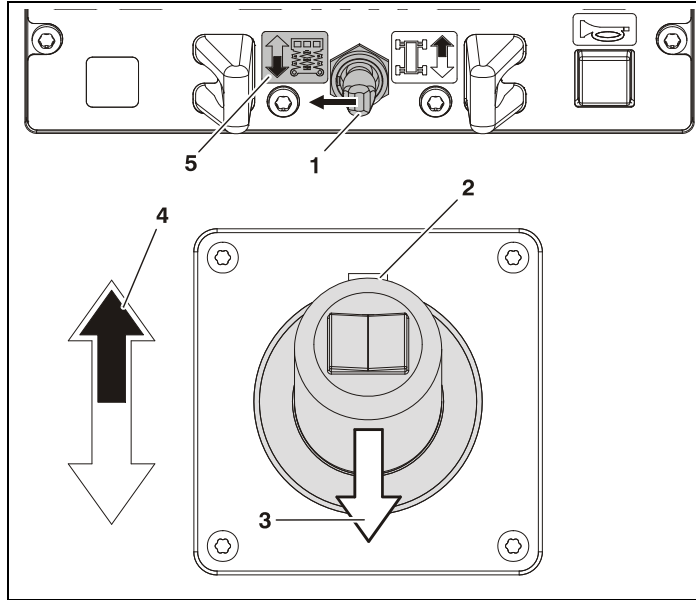

Figure 4-7. Raising Platform From Platform Control

1. If operating from the platform controls -

Set the **lift/drive select switch to lift (1)**, squeeze and hold the **red trigger switch (2)**, move the **joystick backward (3)** (platform up) and hold until desired elevation is reached. Releasing the red trigger switch or moving the joystick back to its centered position will stop the function being operated.

NOTE: To ensure proper orientation of the desired platform function, match the color (black/white) of the directional arrow (4), to the lift/lower arrow (5) on the platform control indicator panel.

Lowering Platform

⚠ WARNING

ENSURE THE AREA BENEATH THE PLATFORM IS FREE OF PERSONNEL PRIOR TO LOWERING.

NOTE: *The machine is equipped with a descent alarm which will sound as the platform is being lowered (optional on CE units).*

From Ground Control Station

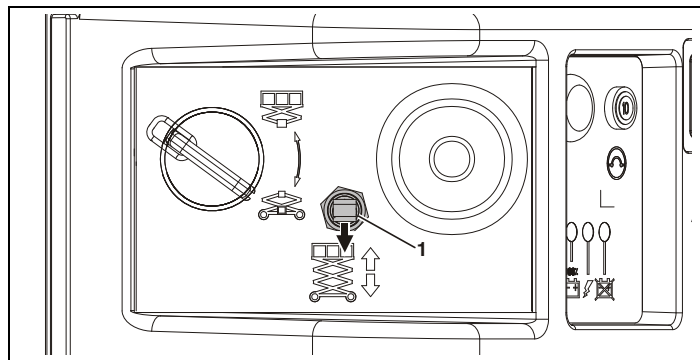

Figure 4-8. Lowering Platform From Ground Control

- 1. If operating from the ground controls -**
Position the **lift switch (1)** to down and hold until desired elevation is achieved or until platform is fully lowered.

⚠ WARNING

DO NOT OPERATE FROM GROUND CONTROL STATION WITH PERSONNEL IN THE PLATFORM EXCEPT IN AN EMERGENCY.

From Platform Control Station

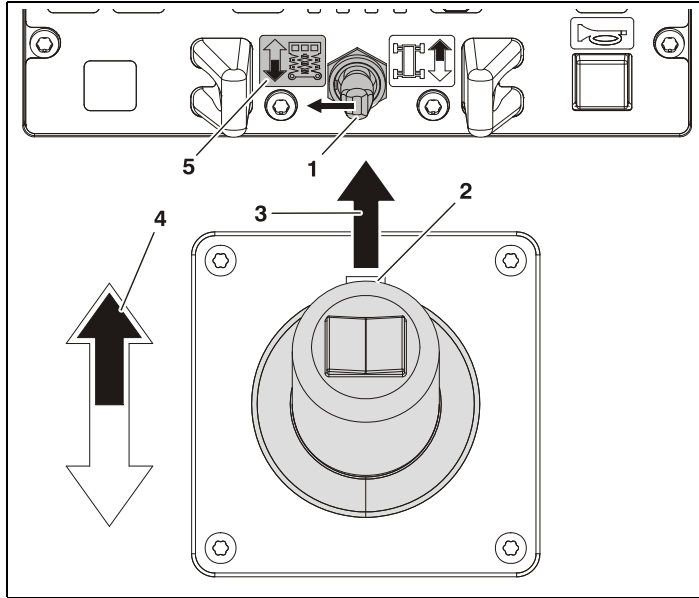

Figure 4-9. Lowering Platform From Platform Control

1. If operating from the platform controls -

Set the **lift/drive select switch to lift (1)** squeeze the **red trigger switch (2)** and push the **joystick forward (3)** (platform down) and hold until desired elevation is reached or until platform is fully lowered. Releasing the red trigger switch or moving the joystick back to its centered position will stop the function being operated.

NOTE: To ensure proper orientation of the desired platform function, match the color (black/white) of the directional arrow (4), to the lift/lower arrow (5) on the platform control indicator panel.

SECTION 4 - MACHINE OPERATION

4.8 STEERING AND TRAVELING

⚠ WARNING

DO NOT DRIVE WITH PLATFORM RAISED EXCEPT ON A SMOOTH, FIRM AND LEVEL SURFACE FREE OF OBSTRUCTIONS AND HOLES.

DO NOT ATTEMPT TO DRIVE THE MACHINE WITH THE PLATFORM RAISED UNLESS THE POT HOLE PROTECTION SYSTEM BARS HAVE BEEN FULLY LOWERED.

TO AVOID LOSS OF TRAVEL CONTROL OR UPSET ON GRADES AND SIDESLOPES, DO NOT DRIVE MACHINE ON GRADES OR SIDESLOPES EXCEEDING THOSE SPECIFIED. REFERENCE FIGURE 4-12. AND TABLE 6-1.

1. Place power selector switch at the ground control station to platform.
2. Position emergency stop switch at platform control station to the on position.

Steering

On the platform control station, set the **lift/drive select switch (1)** to the drive position.

To steer the machine, the thumb operated **steer control switch (2)** on the joystick handle is positioned to the **right (3)** for traveling right, or to the **left (4)** for traveling left. When released, the switch will return to the center-off position and the wheels will remain in the previously selected position. To return the wheels

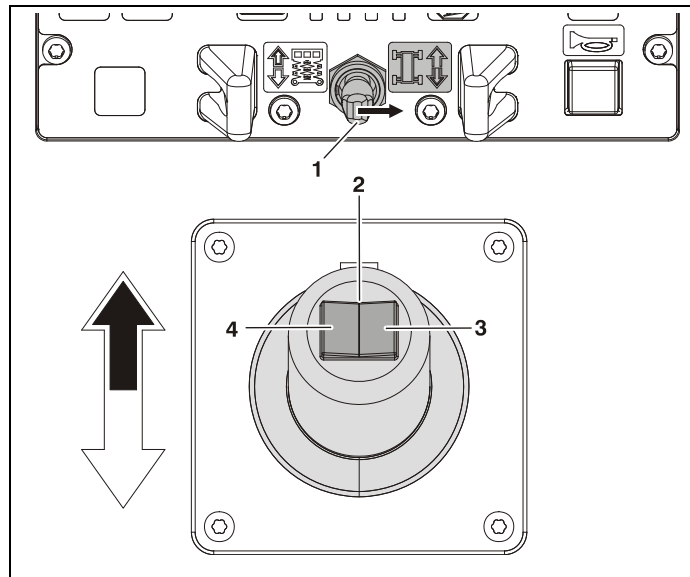

Figure 4-10. Steering from Platform Control

to the straightened position, the switch must be activated in the opposite direction until the wheels are centered.

Driving Forward and Reverse

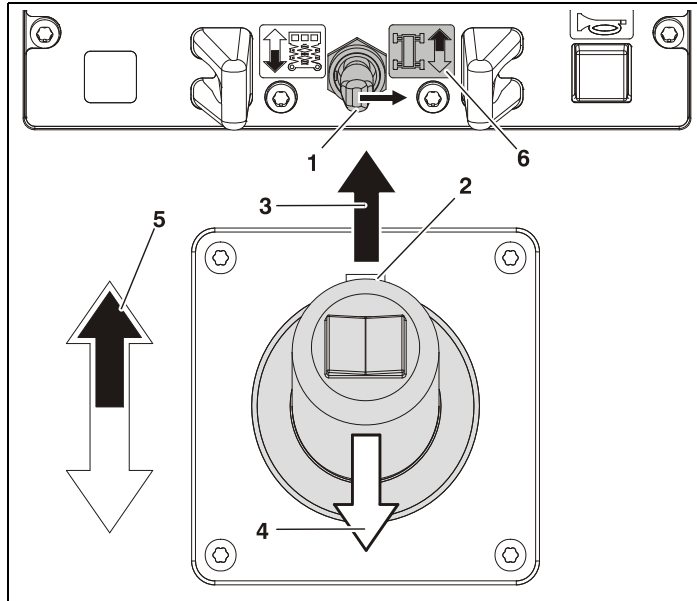

Figure 4-11. Driving Forward from Platform Control

Set the **lift/drive selector switch (1)** to drive mode. Squeeze the **red trigger switch (2)** on front of the joystick, and move the joystick **forward (3)** to drive forward or **backward (4)** to

drive in reverse. The drive system is proportional so for additional drive speed, push the joystick further in the direction of travel. Releasing the red trigger switch or returning the joystick to center will stop the function being operated.

NOTE: To ensure proper orientation of the desired platform function, match the color (black/white) of the directional arrow (5), to the lift/lower arrow (6) on the platform control indicator panel.

⚠ WARNING

IF THE TILT INDICATOR WARNING LIGHT/ALARM IS ACTIVATED WHILE DRIVING WITH PLATFORM RAISED, LOWER PLATFORM COMPLETELY AND DRIVE TO A FIRM LEVEL SURFACE.

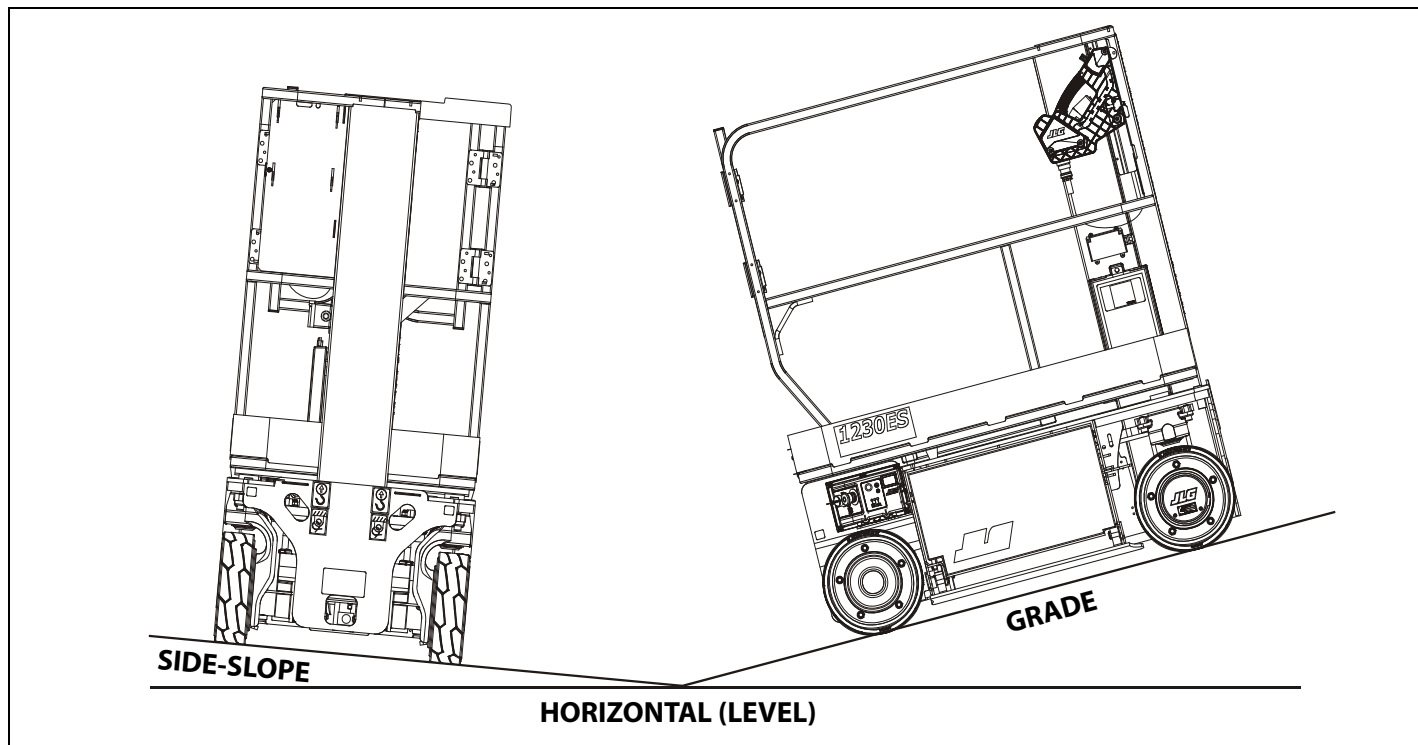

Figure 4-12. Grade and Side-Slope Definition

4.9 PARKING AND STOWING MACHINE

1. Drive the machine to a reasonably well-protected and well-ventilated area.
2. Ensure the platform is fully lowered.
3. At the platform control station, turn the platform - ground selector switch to off and remove the key to disable the machine and prevent unauthorized use.

NOTE: For added protection, the platform control station can be secured to its mounting plate see Figure 4-13.

4. At the ground control station, position the emergency stop switch to the off position.
5. If necessary, cover the instruction placards, caution and warning decals so that they will be protected from hostile environment.
6. Chock at least two wheels when parking the machine for an extended period of time.

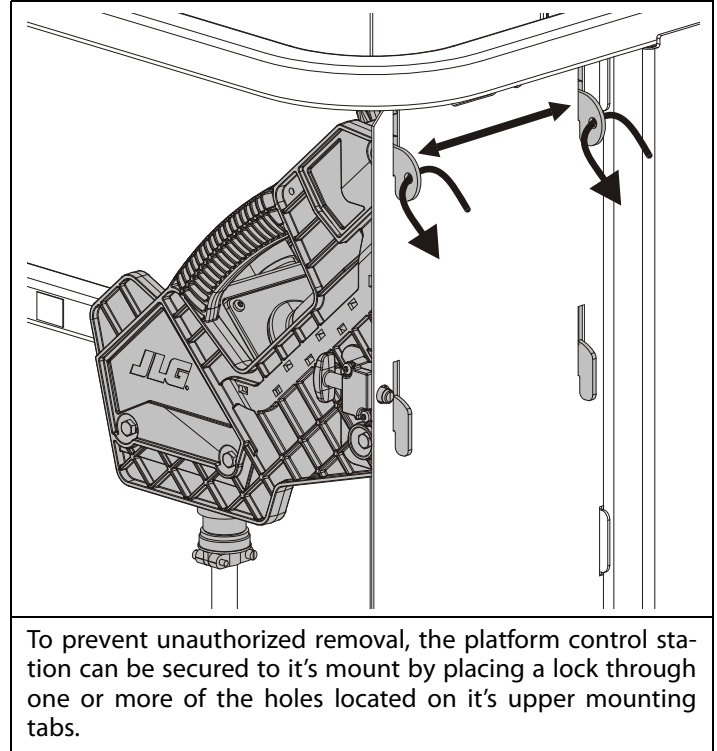

To prevent unauthorized removal, the platform control station can be secured to its mount by placing a lock through one or more of the holes located on its upper mounting tabs.

Figure 4-13. Securing Control Station to Platform.

SECTION 4 - MACHINE OPERATION

4.10 TIE DOWN/LIFT LUGS

See Figure 4-15. on page 4-17

Tie Down

When transporting the machine, the platform must be fully lowered in the stowed position with the machine securely tied down to the truck or trailer deck. There are two tie-down/lift lugs located at the front and rear of the machine for tying down.

Lifting

Reference Figure 4-15. for proper locations when lifting machine. The machine can be lifted using a proper spreader bar and straps/chains only, see Figure 4-15. on page 4-17.

The machine may also be lifted using a fork truck. Lift only with the platform in the stowed position (*pot hole protection bars in the up position*). Adjust the spread of the **fork truck lifting tines (1)** to just inside the machines front and rear wheels, see below.

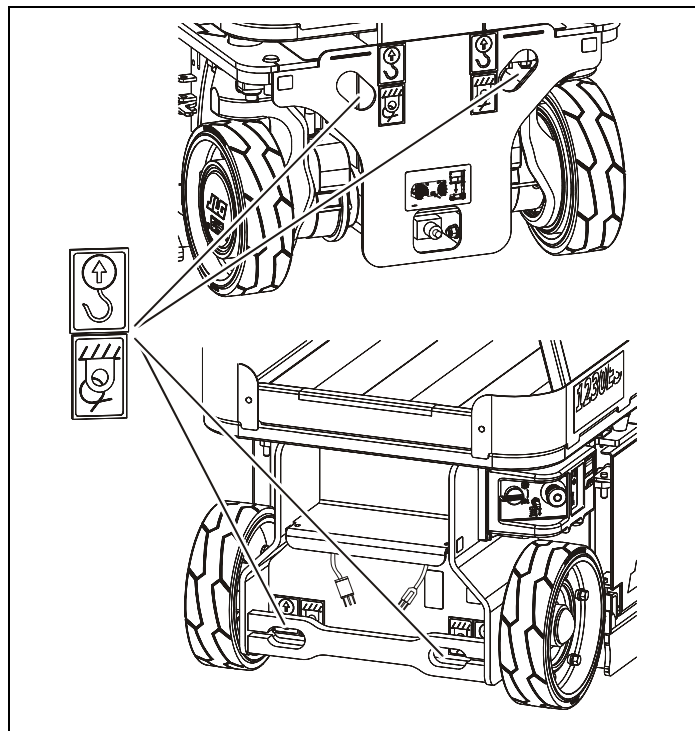
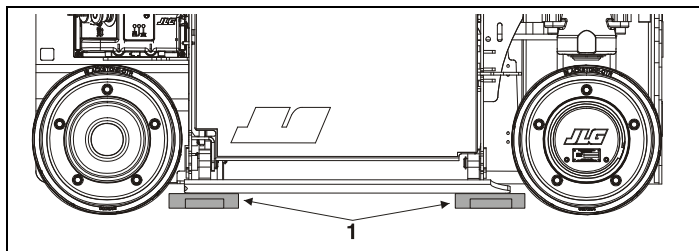

Figure 4-14. Tie Down and Lift Lug Locations.

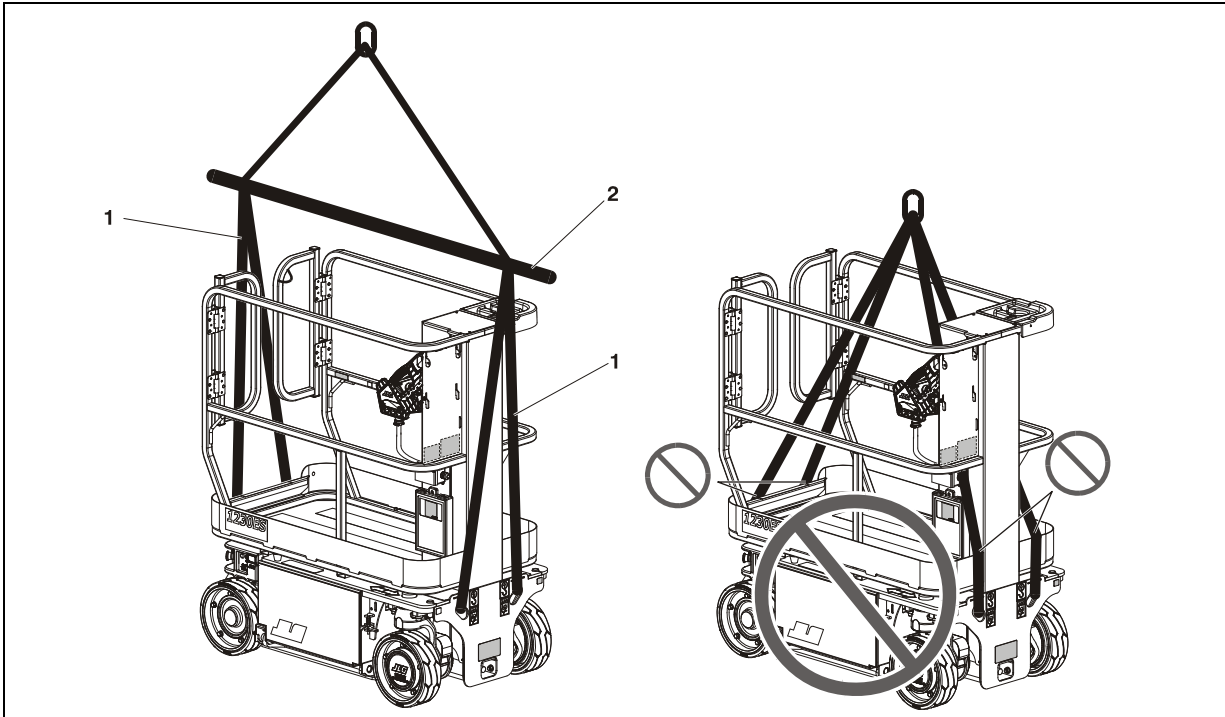

Figure 4-15. Lifting Using Spreader Bar.

1. Lifting Strap or Chains

2. Spreader Bar Assembly

SECTION 4 - MACHINE OPERATION

4.11 TOWING

It is not recommended that this machine be towed, except in the event of an emergency such as a machine malfunction or a total machine power failure.

Electric Brake Release

(See Figure 4-16.)

NOTE: Electrical release of the brakes requires enough battery power to hold the brakes in released mode until destination is reached.

1. Chock wheels or secure machine with tow vehicle.
2. Power up machine in ground mode on the **ground control station (1)**.
3. The **brake release switch (2)** is located on the **lower rear panel (3)**.
4. Depress the brake release switch once to release brakes.
5. When finished towing depress brake release switch again or power machine down at the ground control station to re-engage the brakes.

NOTE: Any action to remove electrical power from the brakes such as, depressing the ground control emergency stop switch, or switching the key switch to OFF or PLATFORM MODE will re-engage the brakes.

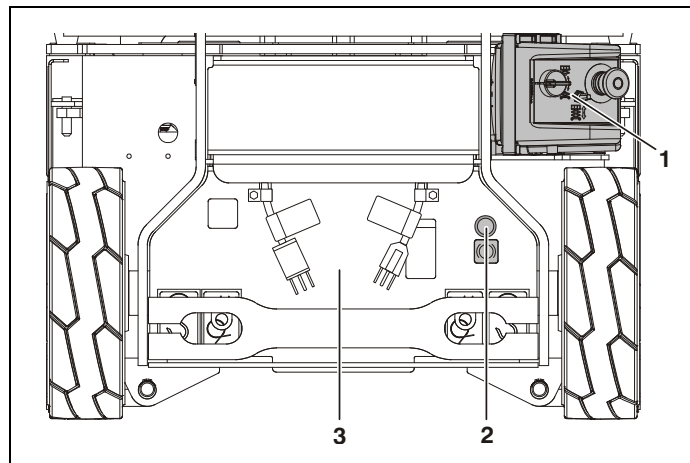

Figure 4-16. Electric Brake Release.

Mechanical Brake Release

(See Figure 4-17.)

1. Chock wheels or secure machine with tow vehicle.
2. At the ground control station power machine down by pressing the E-Stop switch in.
3. Remove the **two cover bolts (1), cover (2), and cover o-ring seal (3)** from the back of drive motor unit.
4. Insert the cover bolts into the **two disengage holes in the brake housing (4)**, see Item 4 in Figure 4-17., Brake - Manual Disengage.
5. Tighten down the cover bolts in the disengage holes and the brake on that drive motor will disengage.
6. Repeat this procedure on opposite wheel drive. With both drive motor brakes now disengaged the machine can be moved manually.
7. After towing is complete, chock wheels and remove cover bolts from disengage holes.
8. Reinstall cover - before installation check the cover o-ring seal for damage, replace if necessary.

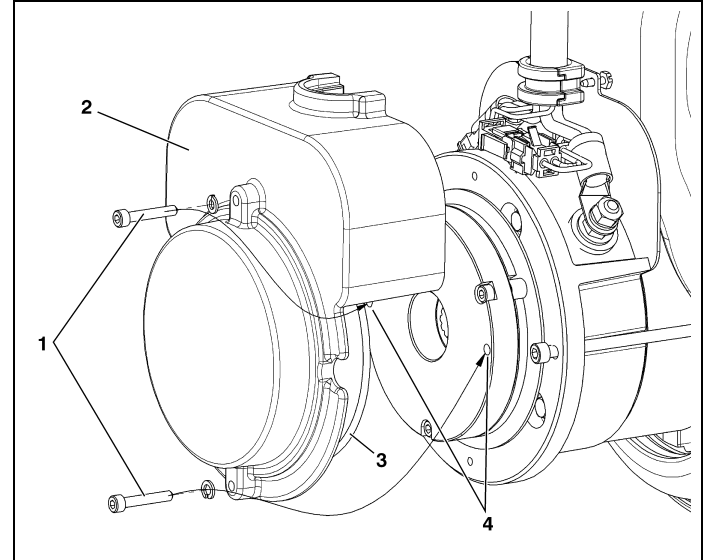

Figure 4-17. Brake - Manual Disengage.

⚠ CAUTION

AFTER THE MACHINE IS TOWED THE DISENGAGE BOLTS MUST BE REMOVED FROM THE BRAKE DISENGAGE HOLES. THE BRAKES CANNOT BE ENGAGED IF THE DISENGAGE BOLTS ARE LEFT IN THE DISENGAGE HOLES. THIS WILL CAUSE THE MACHINE TO ROLL WHEN PARKED ON AN INCLINE.

SECTION 4 - MACHINE OPERATION



NOTES:

<hr/> <hr/> <hr/> <hr/> <hr/> <hr/> <hr/> <hr/> <hr/> <hr/> <hr/> <hr/> <hr/> <hr/> <hr/> <hr/> <hr/> <hr/> <hr/> <hr/> <hr/> <hr/> <hr/>	<hr/> <hr/> <hr/> <hr/> <hr/> <hr/> <hr/> <hr/> <hr/> <hr/> <hr/> <hr/> <hr/> <hr/> <hr/> <hr/> <hr/> <hr/> <hr/> <hr/> <hr/> <hr/> <hr/>
---	---

SECTION 5. EMERGENCY PROCEDURES

5.1 GENERAL INFORMATION

This section explains the steps to be taken in case of an emergency situation during operation.

5.2 EMERGENCY OPERATION

Operator Unable to Control Machine

IF THE PLATFORM OPERATOR IS PINNED, TRAPPED OR UNABLE TO OPERATE OR CONTROL THE MACHINE:

1. Other personnel should operate the machine from ground controls only as required.
2. Only qualified personnel in the platform may use the platform controls. DO NOT CONTINUE OPERATION IF CONTROLS DO NOT FUNCTION PROPERLY.
3. Rescue equipment can be used to remove the platform occupant. Cranes and forklifts can be used to stabilize motion of the machine.

Platform Caught Overhead

If the platform becomes jammed or snagged in overhead structures or equipment, rescue the platform occupant prior to freeing the machine.

5.3 PLATFORM MANUAL DESCENT

The platform manual descent valve is used in the event of total power failure to retract and lower the platform using gravity. The manual descent valve is located at the bottom of the mast assembly on the front of the machine inside an access hole. Look for the instruction decal located just above the access hole. (See Figure 5-1.)

The procedure is as follows:

1. Locate the manual descent valve on the front of the machine at the base of the mast.



WARNING

KEEP HANDS AND ARMS OUT OF THE PATH OF THE MAST AND PLATFORM WHILE LOWERING.

2. Press and hold the RED button on the manual descent valve, release the button when the platform is lowered to desired level.

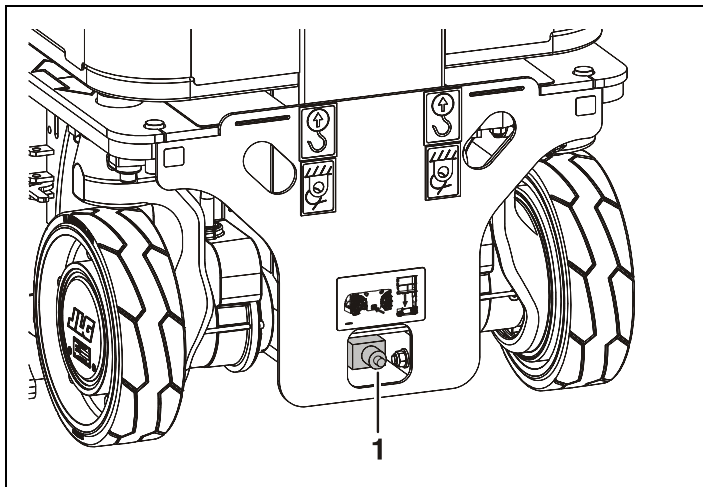

**Figure 5-1. Location of Manual Descent Valve
(Front of Machine)**

5.4 INCIDENT NOTIFICATION

JLG Industries, Inc. must be notified immediately of any incident involving a JLG product. Even if no injury or property damage is evident, the factory should be contacted by telephone and provided with all necessary details.

USA: 877-JLG-SAFE (554-7233)

EUROPE: (44) 1 698 811005

AUSTRALIA: (61) 2 65 811111

E-mail: productsafety@jlg.com

Failure to notify the manufacturer of an incident involving a JLG Industries product within 48 hours of such an occurrence may void any warranty consideration on that particular machine.

NOTICE

FOLLOWING ANY ACCIDENT, THOROUGHLY INSPECT THE MACHINE AND TEST ALL FUNCTIONS FIRST FROM THE GROUND CONTROL STATION, THEN FROM THE PLATFORM CONTROL CONSOLE. DO NOT ELEVATE PLATFORM UNTIL YOU ARE SURE THAT ALL DAMAGE HAS BEEN REPAIRED, IF REQUIRED, AND THAT ALL CONTROLS ARE OPERATING CORRECTLY.

SECTION 6. GENERAL SPECIFICATIONS AND OPERATOR MAINTENANCE

6.1 INTRODUCTION

This section of the manual provides additional necessary information to the operator for proper operation and maintenance of this machine.

The maintenance portion of this section is intended as information to assist the machine operator to perform daily maintenance tasks only, and does not replace the more thorough Preventive Maintenance and Inspection Schedule included in the Service and Maintenance Manual.

Other Publications Available Specific to this Machine:

Service and Maintenance Manual	3121222
Illustrated Parts Manual.....	3121223

SECTION 6 - GENERAL SPECIFICATIONS AND OPERATOR MAINTENANCE

6.1 OPERATING SPECIFICATIONS

Table 6-1. Operating Specification

DESCRIPTION		MODEL 1230ES
PLATFORM		
Maximum Platform Height		12 ft. (3.66 m)
DRIVING		
Maximum Drive Speed	Stowed Elevated	3 mph (4.8 kph) 0.5 mph (0.8 kph)
Maximum Stowed Travel Grade (Gradeability) (Reference Figure 4-12. on page 4-14)		25% (14°)
Maximum Stowed Travel Grade (Sideslope) (Reference Figure 4-12. on page 4-14)		5°
Maximum Elevated Travel Grade (Gradeability)		3° - ANSI 3.4° - CE
Maximum Elevated Travel Grade (Sideslope)		1.5° - ANSI 3.4° - CE
Inside Turning Radius		4.4 in. (11.2 cm)
Outside Turning Radius		57.6 in. (1.46 m)

Table 6-1. Operating Specification (Continued)

DESCRIPTION	MODEL 1230ES
CHASSIS	
Approximate Gross Machine Weight - ANSI/CSA/CE/Australia	1740 lb. (790 kg)
Maximum Tire Load (per wheel)	880 lb. (400 kg)
Ground Bearing Pressure	123 PSI (8.7 kg/cm ²)
Ground Clearance - (pot hole protection system up) (pot hole protection system down)	2.6 in (66 mm) 0.5 in (12.2 mm)
Maximum Operating Wind Speed	ANSI/CSA - 28 mph CE/AUST - 0 m/s - Indoor Use Only
Maximum Horizontal Manual Side Force: (Platform fully extended with Maximum load)	ANSI/CSA - 100 lb force - (445 Newtons) CE/AUST - 200 Newtons - (45 lb force)
Maximum Hydraulic Pressure	1600psi (110 bar)
Electrical System Voltage (DC)	24V

Platform Capacities

Table 6-2. Capacities

MODEL	ANSI/CSA		CE/AUST (INDOOR ONLY)	
	Max. Capacity	Max. Persons	Max. Capacity	Max. Persons
1230ES	500 lb.	2	230 kg	1

Dimensional Data

Table 6-3. Dimensions

DESCRIPTION	MODEL 1230ES	
Platform Height - Elevated	12 ft.	3.66 m
Platform Height - Stowed	22 in.	56 cm
Working Height	18 ft.	5.48 m
Overall Stowed Machine Height	65.25 in.	166 cm
Rail Height (From platform floor)	43.8 in.	111.2 cm
Overall Machine Width	30 in.	76 cm
Overall Machine Length	53.5 in.	1.36 m
Platform Size - Length	49.4 in.	1.26 m
Platform Size - Width	27 in.	0.69 m
Wheelbase	40.75 in.	103.5 cm

SECTION 6 - GENERAL SPECIFICATIONS AND OPERATOR MAINTENANCE

Tires

Table 6-4. Tire Specifications

DESCRIPTION	MODEL 1230ES
Size	12.72 in. x 3.937 in. (323mm x 100mm)
Max Tire Load	2500 lbs (1134 kg)
Wheel Bolt Torque	120 ft lb (163 Nm)

Batteries

Table 6-5. Battery Specifications

DESCRIPTION	MODEL 1230ES
Voltage (24V System - Series)	6 V per battery
Amp Hour - (Std Battery)	220 Amp Hour @ 20 HR. Rate
Reserve Capacity - (Std Battery)	447 Minutes
Amp Hour - (AGM Battery)	213 Amp Hour @ 20 HR. Rate
Reserve Capacity - (AGM Battery)	492 Minutes

6.1 CRITICAL STABILITY WEIGHTS

WARNING

DO NOT REPLACE ITEMS CRITICAL TO STABILITY, SUCH AS BATTERIES OR SOLID TIRES, WITH ITEMS OF DIFFERENT WEIGHT OR SPECIFICATION. DO NOT MODIFY UNIT IN ANY WAY TO AFFECT STABILITY.

Table 6-6. Critical Stability Weights

COMPONENT	MODEL 1230 ES	
Wheel and Tire Assembly (each)	15 lb.	7 kg
Wheel/Tire and Drive Assembly (each)	93 lb.	42 kg
Batteries - Standard (each)	62 lb.	28 kg
Batteries - Standard - Combined	248 lb.	112 kg
Batteries - AGM (each)	69.2 lb.	31.4 kg
Batteries - AGM - Combined	276.8 lb.	125.6 kg

6.1 LUBRICATION

Lubrication Capacities

Table 6-7. Capacities

COMPONENT	MODEL 1230ES
Hydraulic Tank	0.8 Gal. (3L)
Hydraulic System (Including Tank)	1.75 Gal (4.1L)

Hydraulic Oil

Table 6-8. Hydraulic Oil

HYDRAULIC SYSTEM OPERATING TEMPERATURE RANGE	SAE VISCOSITY GRADE
0° F to +23° F (-18° C to -5° C)	10W
0° F to 210° F (-18° C to +99° C)	10W-20, 10W-30
50° F to 210° F (+10° C to +210° C)	20W-20

NOTE: The factory installed hydraulic oil (Nervofluid 15) has a BLUE TINT for identification purposes only, but is fully compatible and can be mixed with any of the JLG recommended hydraulic oils mentioned following.

NOTE: Hydraulic oils must have anti-wear qualities at least to API Service Classification GL-3, and sufficient chemical stability for mobile hydraulic system service. JLG recommends Mobilfluid DTE 11M hydraulic oil, which has an SAE viscosity index of 140.

When temperatures remain below 20° F (-7° C), JLG recommends the use of Mobil DTE13. Aside from JLG recommendations, it is not advisable to mix oils of different brands or types, as they may not contain the same required additives or be of comparable viscosities. If use of hydraulic oil other than Mobilfluid DTE 11M is desired, contact JLG for proper recommendations.

SECTION 6 - GENERAL SPECIFICATIONS AND OPERATOR MAINTENANCE

Lubrication Specifications

Table 6-9. Lubrication Specifications

KEY	SPECIFICATIONS
MPG	Multipurpose Grease having a minimum dripping point of 350°F. Excellent water resistance and adhesive qualities, and being of extreme pressure type. (Timken OK 40 pounds minimum.)
EPGL	Extreme Pressure Gear Lube (oil) meeting API service classification GL-5 or MIL-Spec MIL-L-2105.
HO	Hydraulic Oil. Mobil DTE 11M

Table 6-10. Hydraulic Oil Specifications (OEM)

SPECIFICATION	MOBIL DTE 11M	NERVOFLUID 15
ISO Viscosity Grade	#15	#15
Gravity API	31.9	—
Pour Point, Max	-40°F (-40°C)	-40°C (-40°F)
Flash Point, Min.	330°F (166°C)	175°C (347°F)
VISCOSITY SPECIFICATIONS		
at 40°C	15 cSt	14.9 cSt
at 100°C	4.1 cSt	3.8 cSt
at 100°F	80 SUS	—
at 210°F	43 SUS	—
cp at -30°F	3,200	—
Viscosity Index	140	153

6.1 OPERATOR MAINTENANCE

Oil Check Procedure

- Lube Point(s) - Hydraulic Reservoir
- Reservoir Capacity: 0.80 Gal. (3 L)
- Lube - Hydraulic Oil
- Interval - Check Daily

NOTE: Be certain the hydraulic oil has warmed to operating temperature before checking the oil level in the reservoir.

1. From either side of the machine, open the **side access door on the base frame (1)**. Locate the **hydraulic oil reservoir (2)** on the **pump unit (3)**. Check the oil level in the hydraulic reservoir by looking at the markings on the side of the tank. The reservoir is marked with **MIN (minimum) and MAX (maximum) markings (4)**. The oil level must be within these markings to operate properly.
2. If additional oil is required, wipe all dirt and debris from the **filler/breather cap (5)** area, add proper grade of oil by using a funnel with a flexible spout or a plastic squeeze bottle. Fill until oil level is between the **MIN and MAX markings (4)**.

NOTE: Care should be taken not to introduce any impurities (dirt, water etc.) while cap is removed.

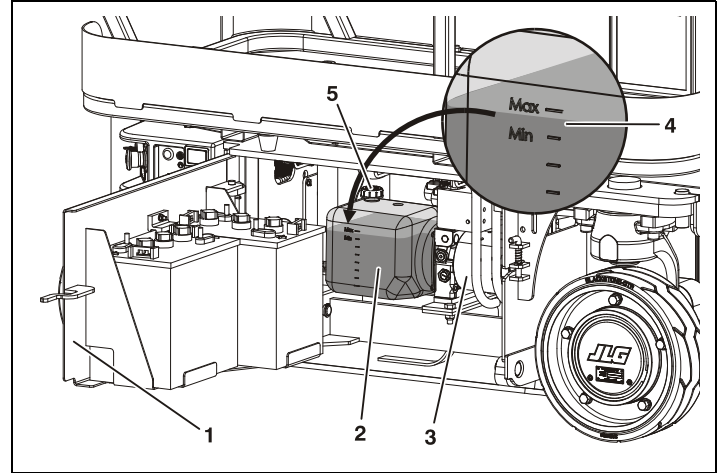

Figure 6-1. Hydraulic Oil Check Procedure

NOTE: Recommended lubricating intervals are based on machine operations under normal conditions. For machines used in multi-shift operations and/or exposed to hostile environments or conditions, lubrication frequencies must be increased accordingly.

6.1 BATTERY MAINTENANCE

Battery Maintenance and Safety Practices

⚠ CAUTION

ENSURE THAT BATTERY ACID DOES NOT COME INTO CONTACT WITH SKIN OR CLOTHING. WEAR PROTECTIVE CLOTHING AND EYEWEAR WHEN WORKING WITH BATTERIES. NEUTRALIZE ANY BATTERY ACID SPILLS WITH BAKING SODA AND WATER.

BATTERY ACID RELEASES AN EXPLOSIVE GAS WHILE CHARGING, ALLOW NO OPEN FLAMES, SPARKS OR LIGHTED TOBACCO PRODUCTS IN THE AREA WHILE CHARGING BATTERIES. CHARGE BATTERIES ONLY IN A WELL VENTILATED AREA.

ADD ONLY DISTILLED WATER TO BATTERIES. WHEN ADDING DISTILLED WATER TO THE BATTERIES, A NON-METALLIC CONTAINER AND/OR FUNNEL MUST BE USED.

As with any wet cell battery, check the electrolyte level of the batteries often, adding only distilled water when required. When fully charged, battery fluid level should be 1/8" below vent tubes. (See Figure 6-2.).

- DO NOT fill to bottom of vent tubes.
- DO NOT allow fluid level to go below the top of the plates when charging or operating.

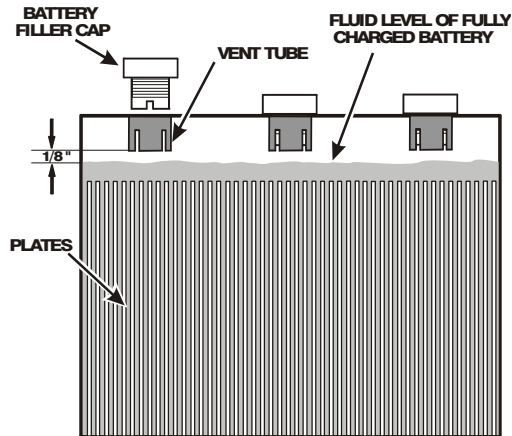

Figure 6-2. Battery Fluid Level.

6.1 TIRES AND WHEELS

Tire Wear and Damage

Inspect tires periodically for wear or damage. Tires with worn edges or distorted profiles require replacement. Tires with significant damage in the tread area or side wall, require immediate evaluation before replacing the machine into service.

Wheel and Tire Replacement

Replacement wheels must have the same diameter and profile as the original. Replacement tires must be the same size and rating as the tire being replaced.

Wheel Installation

It is extremely important to apply and maintain proper wheel mounting torque.

⚠ WARNING

WHEEL LUG NUTS MUST BE INSTALLED AND MAINTAINED AT THE PROPER TORQUE TO PREVENT LOOSE WHEELS, BROKEN LUG NUTS, AND POSSIBLE SEPARATION OF WHEEL FROM THE AXLE. BE SURE TO USE ONLY THE LUG NUTS MATCHED TO THE CONE ANGLE OF THE WHEEL.

Tighten the lug nuts to the proper torque to prevent wheels from coming loose. Use a torque wrench to tighten the fasteners. If you do not have a torque wrench, tighten the fasteners with a lug wrench, then immediately have a service garage or dealer tighten the lug nuts to the proper torque. Over-tightening will result in breaking the lug nuts or permanently deforming the mounting holes in the wheels. The proper procedure for attaching wheels is as follows:

1. Start all lug nuts by hand to prevent cross threading. DO NOT use a lubricant on threads or nuts.
2. Tighten lug nuts in the following sequence.

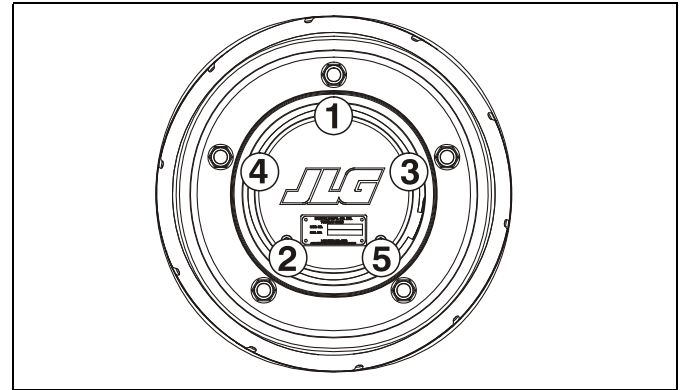

Figure 6-3. Wheel Lug Nut Tightening Sequence

SECTION 6 - GENERAL SPECIFICATIONS AND OPERATOR MAINTENANCE

- Tightening of the lug nuts should be done in stages. Following the recommended sequence, tighten lug nuts per wheel torque.

Table 6-11. Wheel Torque Chart

TORQUE SEQUENCE		
1st Stage	2nd Stage	3rd Stage
20-30 ft lbs (28-42 Nm)	65-80 ft lbs (91-112 Nm)	105-120 ft lbs (142-163 Nm)

- Wheel lug nuts should be torqued after the first 50 hours of operation and after each wheel removal. Check torque every 3 months or 150 hours of operation.

6.1 SUPPLEMENTAL INFORMATION

The following information is provided in accordance with the requirements of the European Machinery Directive 2006/42/EC and is only applicable to CE machines.

For electric powered machines, the equivalent continuous A-Weighted sound pressure level at the work platform is less than 70dB(A).

For combustion engine powered machines, guaranteed Sound Power Level (LWA) per European Directive 2000/ 14/EC (Noise Emission in the Environment by Equipment for Use Outdoors) based on test methods in accordance with Annex III, Part B, Method 1 and 0 of the directive, is 109 dB.

The vibration total value to which the hand-arm system is subjected does not exceed 2,5 m/s². The highest root mean square value of weighted acceleration to which the whole body is subjected does not exceed 0,5 m/s².

6.1 DIAGNOSTIC TROUBLE CODES (DTC)

The DTC tables following are sorted in groups by the first two digits, these digits represent the number of flashes the system distress indicator lamp will flash on the platform indicator panel when a fault occurs.

For example: a “2-1 Power-Up” on page 6-14 would be indicated by 2 flashes, a pause, then 1 flash, a pause, then would keep repeating until the fault is cleared.

The more detailed three digit code numbers in the DTC column of the following tables are only indicated on a JLG handheld diagnostic analyzer.

To troubleshoot multiple DTCs, start with the DTC with the higher first two digits. **If a correction is made during a check, conclude the check by cycling the machine power off then back on, using the emergency stop switch.**

NOTICE

SHOULD A FAULT OCCUR WHICH CANNOT BE CORRECTED AT THE OPERATOR'S LEVEL, THE PROBLEM MUST BE REFERRED TO A MECHANIC QUALIFIED TO REPAIR THIS MODEL OF JLG LIFT.

6.1 DTC CHECK TABLE INDEX

DTC	TABLE	PAGE
0-0	Help Comments	6-12
2-1	Power-Up	6-14
2-2	Platform Controls	6-14
2-5	Function Prevented	6-16
3-1	Line Contactor Open Circuit	6-18
3-2	Line Contactor Short Circuit	6-19
3-3	Ground Output Driver	6-19
4-2	Thermal Limit (SOA)	6-21
4-4	Battery Supply	6-21
6-6	Communication	6-22
6-7	Accessory	6-23
7-7	Electric Motor	6-23
8-1	Tilt Sensor	6-24
8-2	Platform Load Sense	6-25
9-9	Hardware	6-26

6.2 DIAGNOSTIC TROUBLE CODES (DTC) CHECK TABLES

 **0-0 Help Comments**

DTC	FAULT MESSAGE	DESCRIPTION	CHECK
001	EVERYTHING OK	The normal help message in platform mode. Displays on the analyzer only.	
002	GROUND MODE OK	The normal help message in ground mode. Displays on the analyzer only.	
003	ALARM SOUNDING - TILTED & ABOVE ELEVATION	Control system senses that the platform is elevated and the vehicle is tilted, and the machine not configured to cutout.	<ul style="list-style-type: none"> • Check that the machine is tilted. If so, lower the platform and reposition the machine to a level surface. • Fully stow the platform. • The tilt sensor is part of the ground control box. Check that the ground control box is secured to the machine. • Check that the pothole protection switches are securely mounted. • Check that the elevation angle sensor is securely mounted. Refer problem to a qualified JLG mechanic.
004	DRIVING AT CUTBACK - ABOVE ELEVATION	The platform is elevated and the machine is driving.	<ul style="list-style-type: none"> • Fully stow the platform. • Check that the elevation angle sensor is securely mounted. • Check that the pothole protection switches are securely mounted. Refer problem to a qualified JLG mechanic.

 **0-0 Help Comments**

DTC	FAULT MESSAGE	DESCRIPTION	CHECK
005	DRIVE & LIFT UP PREVENTED - TILTED & ELEVATED	Driving is not possible since the platform is elevated and the chassis is not level.	<ul style="list-style-type: none"> • Check that the machine is tilted. If so, lower the platform and reposition the machine to a level surface. • Fully stow the platform. • The tilt sensor is part of the ground control box. Check that the ground control box is secured to the machine. • Check that the pothole protection switches are securely mounted. • Check that the elevation angle sensor is securely mounted. Refer problem to a qualified JLG mechanic.
006	LIFT UP PREVENTED - MAX HEIGHT ZONE A	The vehicle has reached the maximum height and further lift up motion is not possible. Applicable to 2630ES or 3246ES.	<ul style="list-style-type: none"> • Check that the zone is set appropriately for the platform load. • Check that the platform height is at the rated maximum height specification (20' for 2630 or 26' for the 3246). • Check that the elevation angle sensor is securely mounted. • If there are any elevation sensor faults (DTC 251, 252, 2511, or 2512), troubleshoot those first. Refer problem to a qualified JLG mechanic.
007	DRIVING AT CUTBACK - POTHOLE STILL ENGAGED	While stowed, drive speed is reduced since the control system detected that the pothole protection mechanism failed to retract.	<ul style="list-style-type: none"> • Check for obstructions around the pot-hole protection mechanisms. • Check that the PHP switches are securely mounted. Refer problem to a qualified JLG mechanic.
008	FUNCTIONS LOCKED OUT - SYSTEM POWERED DOWN	After 2 hours without activity, the control system enters a low-power state to preserve battery charge.	<ul style="list-style-type: none"> • Normal operation should resume after power is cycled off then back on. • Check batteries charge, condition, etc. Refer problem to a qualified JLG mechanic.

SECTION 6 - GENERAL SPECIFICATIONS AND OPERATOR MAINTENANCE

0-0 Help Comments

DTC	FAULT MESSAGE	DESCRIPTION	CHECK
009	DRIVE PREVENTED - ELEVATED ABOVE DRIVE CUTOUT HEIGHT	The platform is elevated above the calibrated cutout height.	<ul style="list-style-type: none">• Check that the elevation angle sensor is securely mounted. Refer problem to a qualified JLG mechanic.

2-1 Power-Up

DTC	FAULT MESSAGE	DESCRIPTION	CHECK
211	POWER CYCLE	This help message is issued at each power cycle. Displays on the analyzer only.	Normal operation. No check necessary.
212	KEYSWITCH FAULTY	Both platform and ground modes are selected simultaneously. Defaults to ground mode.	Refer problem to a qualified JLG mechanic.

2-2 Platform Controls

DTC	FAULT MESSAGE	DESCRIPTION	CHECK
221	FUNCTION PROBLEM - HORN PERMANENTLY SELECTED	The horn switch was closed during power-up in platform mode.	<ul style="list-style-type: none">• Check if the horn switch is damaged, obstructed or jammed. Refer problem to a qualified JLG mechanic.
222	FUNCTION PROBLEM - INDOOR / OUTDOOR PERMANENTLY SELECTED	The indoor / outdoor (zone A / zone B) switch was closed during power-up in platform mode.	<ul style="list-style-type: none">• Check if the indoor/outdoor (zone A / zone B) capacity switch is damaged, obstructed or jammed. Refer problem to a qualified JLG mechanic.

 **2-2 Platform Controls**

DTC	FAULT MESSAGE	DESCRIPTION	CHECK
223	FUNCTION PROBLEM - DRIVE & LIFT ACTIVE TOGETHER	The drive and lift inputs are closed simultaneously in platform mode.	<ul style="list-style-type: none"> • Check drive/lift switch for visible damage. Refer problem to a qualified JLG mechanic.
224	FUNCTION PROBLEM - STEER LEFT PERMANENTLY SELECTED	The steer left switch was closed during power-up in platform mode.	<ul style="list-style-type: none"> • Check if the steer left switch is obstructed or jammed. Refer problem to a qualified JLG mechanic.
225	FUNCTION PROBLEM - STEER RIGHT PERMANENTLY SELECTED	The steer right switch was closed during power-up in platform mode.	<ul style="list-style-type: none"> • Check if the steer right switch is obstructed or jammed. Refer problem to a qualified JLG mechanic.
226	ACCELERATOR FAULTY - WIPER OUT OF RANGE	There is a problem with the joystick.	<ul style="list-style-type: none"> • Center joystick and check to see if a power cycle will clear DTC. Refer problem to a qualified JLG mechanic.
227	STEER SWITCHES FAULTY	The steer left and steer right inputs were closed simultaneously.	<ul style="list-style-type: none"> • Check if the steer switches are damaged, obstructed or jammed. Refer problem to a qualified JLG mechanic.
228	FUNCTION LOCKED OUT - ACCELERATOR NOT CENTERED	The joystick was not centered at power-up.	<ul style="list-style-type: none"> • Release joystick and allow to center. • Check if the joystick is obstructed or jammed. Refer problem to a qualified JLG mechanic.
229	FUNCTION PROBLEM - TRIGGER PERMANENTLY CLOSED	The trigger switch was closed during power-up in platform mode.	<ul style="list-style-type: none"> • Check if the trigger switch is obstructed or jammed. Refer problem to a qualified JLG mechanic.
2210	TRIGGER CLOSED TOO LONG WHILE IN NEUTRAL	The trigger switch was closed for more than five seconds while the joystick was centered.	<ul style="list-style-type: none"> • Check if the trigger switch is obstructed or jammed. Refer problem to a qualified JLG mechanic.
2232	FUNCTION PROBLEM - DRIVE & LIFT BOTH OPEN	The drive and lift inputs are both de-energized in platform mode.	<ul style="list-style-type: none"> • Check if either function is active, if Yes; Refer problem to a qualified JLG mechanic.

SECTION 6 - GENERAL SPECIFICATIONS AND OPERATOR MAINTENANCE

2-3 Ground Controls

DTC	FAULT MESSAGE	DESCRIPTION	CHECK
231	FUNCTION PROBLEM - LIFT PERMANENTLY SELECTED	The ground control box lift switch was closed up or down, during power-up in ground mode.	<ul style="list-style-type: none">• Check if the lift switch is obstructed or jammed. Refer problem to a qualified JLG mechanic.
232	GROUND LIFT UP / DOWN ACTIVE TOGETHER	The lift up / down inputs are closed simultaneously.	<ul style="list-style-type: none">• Check if the lift switch is obstructed or jammed. Refer problem to a qualified JLG mechanic.
233	FUNCTION PROBLEM - BRAKE RELEASE PERMANENTLY SELECTED	The manual brake release switch was closed during power-up.	<ul style="list-style-type: none">• Check if the brake release switch is obstructed or jammed. Refer problem to a qualified JLG mechanic.

2-5 Function Prevented

DTC	FAULT MESSAGE	DESCRIPTION	CHECK
251	ELEV ANGLE SENSOR FAULTY - VOLTAGE OUT OF RANGE	There is a problem with the elevation angle sensor input.	<ul style="list-style-type: none">• Check that the platform elevation sensor is securely mounted and undamaged. Refer problem to a qualified JLG mechanic.
252	ELEV ANGLE SENSOR HAS NOT BEEN CALIBRATED	The elevation angle sensor has not been calibrated.	Refer problem to a qualified JLG mechanic.
253	DRIVE PREVENTED - CHARGER CONNECTED	Driving is not possible while the vehicle is charging.	<ul style="list-style-type: none">• Check if the charger is connected to off board power source and disconnect if desired. Refer problem to a qualified JLG mechanic.

 2-5 Function Prevented

DTC	FAULT MESSAGE	DESCRIPTION	CHECK
254	DRIVE & LIFT UP PREVENTED - CHARGER CONNECTED	Drive or lift is not possible while the vehicle is charging AND is configured to prevent all motion.	<ul style="list-style-type: none"> • Check if the charger is connected to off board power source and disconnect if desired. Refer problem to a qualified JLG mechanic.
255	PLATFORM OVERLOADED	The load sensing system measured platform load is excessive.	<ul style="list-style-type: none"> • Remove excess weight from the platform. • Check that the platform is not caught on something, preventing up or down movement. Refer problem to a qualified JLG mechanic.
256	DRIVE PREVENTED - POT-HOLE NOT ENGAGED	Driving is not possible while elevated since the pot-hole protection system failed to deploy.	<ul style="list-style-type: none"> • Check for obstructions or mechanical problems around the pot-hole protection mechanisms. • Check that the PHP switches are securely mounted. Refer problem to a qualified JLG mechanic.
257	ELEV PROX PERMANENTLY CLOSED - CHECK PROX AND ANGLE ADJUSTMENT	The elevation proximity switch shows the platform to be stowed, while the elevation angle sensor shows the platform to be raised. The elevation proximity switch is only found on certain older lifts. This switch is not used on current machines so this DTC should not occur.	Refer problem to a qualified JLG mechanic.
258	DRIVE & LIFT PREVENTED - BRAKES ELECTRICALLY RELEASED FOR TOWING	Manual brake release mode is activated with the switch in the battery box near the ground control box. Drive or lift is not possible.	<ul style="list-style-type: none"> • Push manual brake release switch again or cycle power to clear manual brake release mode. • Check if the brake release switch is obstructed or jammed. Refer problem to a qualified JLG mechanic.

SECTION 6 - GENERAL SPECIFICATIONS AND OPERATOR MAINTENANCE

2-5 Function Prevented

DTC	FAULT MESSAGE	DESCRIPTION	CHECK
259	MODEL CHANGED - HYDRAULICS SUSPENDED - CYCLE EMS	The model selection has been changed.	Refer problem to a qualified JLG mechanic.
2510	DRIVE PREVENTED - BRAKES NOT RELEASING	There is a problem with the drive or brake system.	<ul style="list-style-type: none">• Ensure vehicle is not stuck on something preventing movement. Refer problem to a qualified JLG mechanic.
2511	ELEV ANGLE SENSOR FAULTY - NOT MOUNTED	The input voltage from the elevation angle sensor indicates the elevation angle sensor is not mounted.	<ul style="list-style-type: none">• Check that the elevation angle sensor is securely mounted. Refer problem to a qualified JLG mechanic.
2512	ELEV ANGLE SENSOR NOT DETECTING CHANGE	The input voltage from the elevation angle sensor did not change while vehicle was lifting up.	<ul style="list-style-type: none">• Check that the elevation angle sensor is securely mounted. Refer problem to a qualified JLG mechanic.

3-1 Line Contactor Open Circuit

DTC	FAULT MESSAGE	DESCRIPTION	CHECK
311	OPEN CIRCUIT LINE CONTACTOR	There is a problem with the line contactor.	Refer problem to a qualified JLG mechanic.
312	CONTACTOR DRIVER PERMANENTLY OFF	There is a problem with the power module line contactor control.	Refer problem to a qualified JLG mechanic.

 3-2 Line Contactor Short Circuit

DTC	FAULT MESSAGE	DESCRIPTION	CHECK
321	LINE CONTACTOR MISWIRED ON OR WELDED	There is a problem with the line contactor.	Refer problem to a qualified JLG mechanic.
322	CONTACTOR DRIVER PERMANENTLY ON	There is a problem with the power module line contactor control.	Refer problem to a qualified JLG mechanic.
326	AUXILIARY RELAY - SHORT TO BATTERY	There is a problem with the auxiliary relay contacts or wiring.	Refer problem to a qualified JLG mechanic.

 3-3 Ground Output Driver

DTC	FAULT MESSAGE	DESCRIPTION	CHECK
331	BRAKE SHORT TO BATTERY	A problem has been detected in this function.	Refer problem to a qualified JLG mechanic.
332	BRAKE OPEN CIRCUIT	A problem has been detected in this function.	Refer problem to a qualified JLG mechanic.
333	LIFT UP SHORT TO BATTERY	A problem has been detected in this function.	Refer problem to a qualified JLG mechanic.
334	LIFT UP OPEN CIRCUIT	A problem has been detected in this function.	Refer problem to a qualified JLG mechanic.
335	LIFT DN SHORT TO BATTERY	A problem has been detected in this function.	Refer problem to a qualified JLG mechanic.
336	LIFT DN OPEN CIRCUIT	A problem has been detected in this function.	Refer problem to a qualified JLG mechanic.
337	STEER LEFT SHORT TO BATTERY	A problem has been detected in this function.	Refer problem to a qualified JLG mechanic.
338	STEER LEFT OPEN CIRCUIT	A problem has been detected in this function.	Refer problem to a qualified JLG mechanic.

SECTION 6 - GENERAL SPECIFICATIONS AND OPERATOR MAINTENANCE

3-3 Ground Output Driver

DTC	FAULT MESSAGE	DESCRIPTION	CHECK
339	STEER RIGHT SHORT TO BATTERY	A problem has been detected in this function.	Refer problem to a qualified JLG mechanic.
3310	STEER RIGHT OPEN CIRCUIT	A problem has been detected in this function.	Refer problem to a qualified JLG mechanic.
3311	GROUND ALARM SHORT TO BATTERY	A problem has been detected in this function.	Refer problem to a qualified JLG mechanic.
3312	LEFT BRAKE SHORT TO BATTERY	A problem has been detected in this function.	Refer problem to a qualified JLG mechanic.
3313	RIGHT BRAKE SHORT TO BATTERY	A problem has been detected in this function.	Refer problem to a qualified JLG mechanic.
3314	LEFT BRAKE OPEN CIRCUIT	A problem has been detected in this function.	Refer problem to a qualified JLG mechanic.
3315	RIGHT BRAKE OPEN CIRCUIT	A problem has been detected in this function.	Refer problem to a qualified JLG mechanic.
33297	LEFT BRAKE - SHORT TO GROUND	A problem has been detected in this function.	Refer problem to a qualified JLG mechanic.
33298	STEER LEFT VALVE - SHORT TO GROUND	A problem has been detected in this function.	Refer problem to a qualified JLG mechanic.
33299	LINE CONTACTOR COIL - SHORT TO BATTERY	A problem has been detected in this function.	Refer problem to a qualified JLG mechanic.
33302	NEGATIVE SUPPLY - SHORT TO BATTERY	A problem has been detected in this function.	Refer problem to a qualified JLG mechanic.
33303	NEGATIVE SUPPLY - SHORT TO GROUND	A problem has been detected in this function.	Refer problem to a qualified JLG mechanic.
33304	RIGHT BRAKE - SHORT TO GROUND	A problem has been detected in this function.	Refer problem to a qualified JLG mechanic.
33305	STEER RIGHT VALVE - SHORT TO GROUND	A problem has been detected in this function.	Refer problem to a qualified JLG mechanic.
33406	LIFT UP VALVE - SHORT TO GROUND	A problem has been detected in this function.	Refer problem to a qualified JLG mechanic.
33407	LIFT DN VALVE - SHORT TO GROUND	A problem has been detected in this function.	Refer problem to a qualified JLG mechanic.

 **4-2 Thermal Limit (SOA)**

DTC	FAULT MESSAGE	DESCRIPTION	CHECK
421	POWER MODULE TOO HOT - PLEASE WAIT	The power module has reached thermal cut-out.	<ul style="list-style-type: none"> • Power down and allow to cool. • Do not operate in ambients over 140° F (60° C). Refer problem to a qualified JLG mechanic.
422	DRIVING AT CUTBACK - POWER MODULE CURRENT LIMIT	The drive portion of the power module has reached thermal limit.	Refer problem to a qualified JLG mechanic.
423	LIFT UP AT CUTBACK - POWER MODULE CURRENT LIMIT	The lift up portion of the power module has reached thermal limit.	Refer problem to a qualified JLG mechanic.

 **4-4 Battery Supply**

DTC	FAULT MESSAGE	DESCRIPTION	CHECK
441	BATTERY VOLTAGE TOO LOW - SYSTEM SHUTDOWN	A problem has been detected with the batteries or power module.	<ul style="list-style-type: none"> • Recharge batteries or check for damaged batteries. • Check battery charger function. Refer problem to a qualified JLG mechanic.
442	BATTERY VOLTAGE TOO HIGH - SYSTEM SHUTDOWN	A problem has been detected with the batteries or power module.	<ul style="list-style-type: none"> • May be due to improper battery charging or incorrect voltage batteries being used. Refer problem to a qualified JLG mechanic.
443	LSS BATTERY VOLTAGE TOO HIGH	A problem has been detected with the load sense system.	<ul style="list-style-type: none"> • May be due to improper battery charging or incorrect voltage batteries being used. Refer problem to a qualified JLG mechanic.

SECTION 6 - GENERAL SPECIFICATIONS AND OPERATOR MAINTENANCE

4-4 Battery Supply

DTC	FAULT MESSAGE	DESCRIPTION	CHECK
444	LSS BATTERY VOLTAGE TOO LOW	A problem has been detected with the load sense system.	<ul style="list-style-type: none">• Recharge batteries or check for damaged batteries. Refer problem to a qualified JLG mechanic.
446 4421 4422	LOGIC SUPPLY VOLTAGE OUT OF RANGE	The System Module logic supply voltage was measured to be out of normal operating range.	<ul style="list-style-type: none">• Check for severely discharged battery, loose cables or for damaged battery; otherwise;• Refer problem to a qualified JLG mechanic.

6-6 Communication

DTC	FAULT MESSAGE	DESCRIPTION	CHECK
661	CANBUS FAILURE - POWER MODULE	The control system failed to receive messages from the power module.	Refer problem to a qualified JLG mechanic.
662	CANBUS FAILURE - PLATFORM MODULE	In platform mode, the control system failed to receive messages from the platform board.	Refer problem to a qualified JLG mechanic.
663	CANBUS FAILURE - LOAD SENSING SYSTEM MODULE	With load sensing system enabled, the control system failed to receive messages from the load sensing system module.	Refer problem to a qualified JLG mechanic.
664	CANBUS FAILURE - ACCESSORY MODULE	An accessory module has stopped communication.	<ul style="list-style-type: none">• See accessory module documentation for troubleshooting. Refer problem to a qualified JLG mechanic.
6635	CANBUS FAILURE - CHASSIS TILT SENSOR	Machine control system lost communication with the machines' tilt sensor.	<ul style="list-style-type: none">• Refer problem to a qualified JLG mechanic.

 **6-7 Accessory**

DTC	FAULT MESSAGE	DESCRIPTION	CHECK
671	ACCESSORY FAULT	An accessory module is reporting a fault.	<ul style="list-style-type: none"> • See accessory module documentation for troubleshooting. Refer problem to a qualified JLG mechanic.

 **7-7 Electric Motor**

DTC	FAULT MESSAGE	DESCRIPTION	CHECK
771	OPEN CIRCUIT DRIVE MOTOR WIRING	The power module detected a problem in the drive motors' power circuit wiring.	Refer problem to a qualified JLG mechanic.
772	STALLED TRACTION MOTOR OR POWER WIRING ERROR	The power module detected a problem in the drive motors' power circuit wiring.	Refer problem to a qualified JLG mechanic.
773	CAPACITOR BANK FAULT - CHECK POWER CIRCUITS	The power module detected a problem in the pump or drive motors' power circuit wiring.	Refer problem to a qualified JLG mechanic.
774	SHORT CIRCUIT FIELD WIRING	The power module detected a problem in the drive motors' power circuit wiring.	Refer problem to a qualified JLG mechanic.
775	OPEN CIRCUIT FIELD WIRING	The power module detected a problem in the drive motors' power circuit wiring.	Refer problem to a qualified JLG mechanic.
776	STALLED PUMP MOTOR OR POWER WIRING ERROR	The power module detected a problem in the drive motors' power circuit wiring.	Refer problem to a qualified JLG mechanic.

SECTION 6 - GENERAL SPECIFICATIONS AND OPERATOR MAINTENANCE

7-7 Electric Motor

DTC	FAULT MESSAGE	DESCRIPTION	CHECK
777	OPEN CIRCUIT PUMP MOTOR WIRING	The power module detected a problem in the drive motors' power circuit wiring.	Refer problem to a qualified JLG mechanic.
778	TRACTION T HIGH - CHECK POWER CIRCUITS	The power module detected a problem in the drive motors' power circuit wiring.	Refer problem to a qualified JLG mechanic.
779	TRACTION T LOW - CHECK POWER CIRCUITS	The power module detected a problem in the drive motors' power circuit wiring.	Refer problem to a qualified JLG mechanic.
7710	PUMP P HIGH - CHECK POWER CIRCUITS	The power module detected a problem in the drive motors' power circuit wiring.	Refer problem to a qualified JLG mechanic.
7711	PUMP P LOW - CHECK POWER CIRCUITS	The power module detected a problem in the drive motors' power circuit wiring.	Refer problem to a qualified JLG mechanic.
7741	ARMATURE BRAKING CURRENT TOO HIGH	The power module has detected excessive braking current.	This can be caused by transporting an excessive load on a steep grade.
7742	FIELD VOLTAGE IMPROPER	The power module detected a problem in the drive motors' power circuit wiring.	Recycle power on/off, if problem persists; Refer problem to a qualified JLG mechanic.

8-1 Tilt Sensor

DTC	FAULT MESSAGE	DESCRIPTION	CHECK
811	TILT SENSOR NOT CALIBRATED	The tilt sensor calibration has not been performed.	Refer problem to a qualified JLG mechanic.

 **8-1 Tilt Sensor**

DTC	FAULT MESSAGE	DESCRIPTION	CHECK
812	NO DATA FROM TILT SENSOR - NOT CONNECTED OR FAULTY	No signal from tilt sensor.	Refer problem to a qualified JLG mechanic.

 **8-2 Platform Load Sense**

DTC	FAULT MESSAGE	DESCRIPTION	CHECK
821	LSS CELL #1 ERROR	A problem has been detected with the load sense system.	Refer problem to a qualified JLG mechanic.
822	LSS CELL #2 ERROR	A problem has been detected with the load sense system.	Refer problem to a qualified JLG mechanic.
823	LSS CELL #3 ERROR	A problem has been detected with the load sense system.	Refer problem to a qualified JLG mechanic.
824	LSS CELL #4 ERROR	A problem has been detected with the load sense system.	Refer problem to a qualified JLG mechanic.
825	LSS HAS NOT BEEN CALIBRATED	The load sensing system module has not been calibrated	Refer problem to a qualified JLG mechanic.

SECTION 6 - GENERAL SPECIFICATIONS AND OPERATOR MAINTENANCE

9-9 Hardware

DTC	FAULT MESSAGE	DESCRIPTION	CHECK
991	LSS WATCHDOG RESET	A problem has been detected with the load sense system.	Refer problem to a qualified JLG mechanic.
992	LSS EEPROM ERROR	A problem has been detected with the load sense system.	Refer problem to a qualified JLG mechanic.
993	LSS INTERNAL ERROR - PIN EXCITATION	A problem has been detected with the load sense system.	Refer problem to a qualified JLG mechanic.
994	LSS INTERNAL ERROR - DRDY MISSING FROM A/D	A problem has been detected with the load sense system.	Refer problem to a qualified JLG mechanic.
995	POWER MODULE FAILURE - PERSONALITY RANGE ERROR	A problem has been detected with the power module.	Refer problem to a qualified JLG mechanic.
996	POWER MODULE FAILURE - INTERNAL ERROR	A problem has been detected with the power module.	Refer problem to a qualified JLG mechanic.
997	POWER MODULE FAILURE - CHECK POWER CIRCUITS OR MOSFET SHORT CIRCUIT	A problem has been detected with the power module.	Refer problem to a qualified JLG mechanic.
998	EEPROM FAILURE - CHECK ALL SETTINGS	A problem has been detected with the ground board.	Refer problem to a qualified JLG mechanic.
999	FUNCTION LOCKED OUT - POWER MODULE SOFTWARE VERSION IMPROPER	The power module software version is not compatible with the rest of the system.	Refer problem to a qualified JLG mechanic.

 9-9 Hardware

DTC	FAULT MESSAGE	DESCRIPTION	CHECK
9910	FUNCTION LOCKED OUT - PLATFORM MODULE SOFTWARE VERSION IMPROPER	The platform board software version is not compatible with the rest of the system.	Refer problem to a qualified JLG mechanic.
9911	FUNCTION LOCKED OUT - LSS MODULE SOFTWARE VERSION IMPROPER	The load sensing system module software version is not compatible with the rest of the system.	Refer problem to a qualified JLG mechanic.
9912	POWER MODULE FAILURE - SYSTEM MONITOR	A problem has been detected with the power module.	Refer problem to a qualified JLG mechanic.
9924	FUNCTIONS LOCKED OUT - MACHINE NOT CONFIGURED	A new ground board was installed but not configured.	Refer problem to a qualified JLG mechanic.

SECTION 6 - GENERAL SPECIFICATIONS AND OPERATOR MAINTENANCE

9-9 Hardware

DTC	FAULT MESSAGE	DESCRIPTION	CHECK
9950 9951 9952 9953 9954 9955 9956 9957 9958 9960 9962 9963 9964 9969 9971 9970 99143 99144 99145 99146 99147 99148 99149	POWER MODULE FAILURE - INTERNAL ERROR	A problem has been detected with the power module.	Cycle machine power on /off a few times if this doesn't clear the DTC, refer problem to a qualified JLG mechanic.

SECTION 7. INSPECTION AND REPAIR LOG

Machine Serial Number _____

Table 7-1. Inspection and Repair Log

DATE	COMMENTS

SECTION 7 - INSPECTION AND REPAIR LOG

Table 7-1. Inspection and Repair Log

DATE	COMMENTS

PROPOSITION 65 WARNING

- **Battery posts, terminals and related accessories contain lead and lead compounds, chemicals known to the State of California to cause cancer and reproductive harm.**
- **Batteries also contain other chemicals known to the State of California to cause cancer.**
- **Wash hands after handling.**



An Oshkosh Corporation Company

JLG Industries, Inc.
1 JLG Drive
McConnellsburg PA.
17233-9533
USA

 **(717) 485-5161**

 **(717) 485-6417**

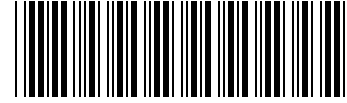

3121221

JLG Worldwide Locations

JLG Industries (Australia)
P.O. Box 5119
11 Bolwarra Road
Port Macquarie
N.S.W. 2444
Australia

 +61 2 65 811111

 +61 2 65 810122

JLG Latino Americana Ltda.
Rua Eng. Carlos Stevenson,
80-Suite 71
13092-310 Campinas-SP
Brazil

 +55 19 3295 0407

 +55 19 3295 1025

JLG Industries (UK) Ltd
Bentley House
Bentley Avenue
Middleton
Greater Manchester
M24 2GP - England

 +44 (0)161 654 1000

 +44 (0)161 654 1001

JLG France SAS
Z.I. de Fauillet
47400 Tonneins
France

 +33 (0)5 53 88 31 70

 +33 (0)5 53 88 31 79

JLG Deutschland GmbH
Max-Planck-Str. 21
D - 27721 Ritterhude - Ihlpohl
Germany

 +49 (0)421 69 350 20

 +49 (0)421 69 350 45

JLG Equipment Services Ltd.
Rm 1107 Landmark North
39 Lung Sum Avenue
Sheung Shui N. T.
Hong Kong

 (852) 2639 5783

 (852) 2639 5797

JLG Industries (Italia) s.r.l.
Via Po. 22
20010 Pregnana Milanese - MI
Italy

 +39 029 359 5210

 +39 029 359 5845

Oshkosh - JLG Singapore T. E. P. Ltd.
29 Tuas Ave 4
Jurong Industrial Estate
639379
Singapore

 +65-6591-9030

 +65-6591-9031

Plataformas Elevadoras
JLG Iberica, S.L.
Trapadella, 2
Pl. Castellbisbal Sur
08755 Castellbisbal, Barcelona
Spain

 +34 93 772 4700

 +34 93 771 1762

JLG Sverige AB
Enkopingsvagen 150
Box 704
SE - 176 27 Jarfalla
Sweden

 +46 (0)850 659 500

 +46 (0)850 659 534

www.jlg.com