

Snorkel

Operator's Manual

MHP 15J

**Engine Powered
Gasoline
Battery Electric**



LIMITED WARRANTY

Snorkel warrants each new machine manufactured and sold by it to be free from defects in material and workmanship for a period of one (1) year from date of delivery to a Customer or for one year after the machine has been placed in first service in a Dealer rental fleet, whichever comes first. Any part or parts which, upon examination by the Snorkel Service Department, are found to be defective, will be replaced or repaired, at the sole discretion of Snorkel, through its local Authorized Dealer at no charge.

Snorkel further warrants the structural components; specifically, the mainframe chassis, turntable, booms and scissor arms, of each new machine manufactured by it to be free from defects in material and workmanship for an additional period of four (4) years. Any such part or parts which, upon examination by the Snorkel Service Department, are found to be defective will be replaced or repaired by Snorkel through its local Authorized Dealer at no charge; however, any labor charges incurred as a result of such replacement or repair will be the responsibility of the Customer or Dealer.

The Snorkel Service Department must be notified within forty-eight (48) hours of any possible warranty situation during the applicable warranty period. Personnel performing warranty repair or replacement must obtain specific approval by Snorkel Service Department prior to performing any warranty repair or replacement.

Customer and Dealer shall not be entitled to the benefits of this warranty and Snorkel shall have no obligations hereunder unless the "Pre-Delivery and Inspection Report" has been properly completed and returned to the Snorkel Service Department within ten (10) days after delivery of the Snorkel product to Customer or Dealer's rental fleet. Snorkel must be notified, in writing, within ten (10) days, of any machine sold to a Customer from a Dealer's rental fleet during the warranty period.

At the direction of the Snorkel Service Department, any component part(s) of Snorkel products to be replaced or repaired under this warranty program must be returned freight prepaid to the Snorkel Service Department for inspection. All warranty replacement parts will be shipped freight prepaid (standard ground) from the Snorkel Service Department or from Snorkel's Vendor to Dealer or Customer.

REPLACEMENT PARTS WARRANTY

Any replacement or service part made or sold by Snorkel is not subject to the preceding **Limited Warranty** beyond the normal warranty period of the machine upon which the part was installed.

THIS WARRANTY EXCLUDES AND SNORKEL DOES NOT WARRANT:

1. Engines, motors, tires and batteries which are manufactured by suppliers to Snorkel, who furnish their own warranty. Snorkel will, however, to the extent permitted, pass through any such warranty protection to the Customer or Dealer.
2. Any Snorkel product which has been modified or altered outside Snorkel's factory without Snorkel's written approval, if such modification or alteration, in the sole judgment of Snorkel's Engineering and/or Service Departments, adversely affects the stability, reliability or service life of the Snorkel product or any component thereof.
3. Any Snorkel product which has been subject to misuse, improper maintenance or accident. "Misuse" includes but is not limited to operation beyond the factory-rated load capacity and speeds. "Improper maintenance" includes but is not limited to failure to follow the recommendations contained in the Snorkel Operation, Maintenance, Repair Parts Manuals. Snorkel is not responsible for normal maintenance, service adjustments and replacements, including but not limited to hydraulic fluid, filters and lubrication.
4. Normal wear of any Snorkel component part(s). Normal wear of component parts may vary with the type application or type of environment in which the machine may be used; such as, but not limited to sandblasting applications.
5. Any Snorkel product that has come in direct contact with any chemical or abrasive material.
6. Incidental or consequential expenses, losses, or damages related to any part or equipment failure, including but not limited to freight cost to transport the machine to a repair facility, downtime of the machine, lost time for workers, lost orders, lost rental revenue, lost profits or increased cost.

This warranty is expressly in lieu of all other warranties, representations or liabilities of Snorkel, either expressed or implied, unless otherwise amended in writing by Snorkel's President, Vice President-Engineering, Vice President-Sales or Vice President-Marketing.

SNORKEL MAKES NO WARRANTIES WHICH EXTEND BEYOND THE DESCRIPTION OF THIS LIMITED WARRANTY. SNORKEL MAKES NO IMPLIED WARRANTY OF MERCHANTABILITY OR FITNESS FOR A PARTICULAR PURPOSE AND DISCLAIMS ALL LIABILITY FOR INCIDENTAL OR CONSEQUENTIAL DAMAGES, INCLUDING BUT NOT LIMITED TO INJURY TO PERSONS OR PROPERTY.

The Customer shall make all warranty claims through its local Authorized Dealer and should contact the Dealer from whom the Snorkel product was purchased for warranty service. Or, if unable to contact the Dealer, contact the Snorkel Service Department for further assistance.

■ Electrical Hazard Warning

 **DANGER**

**THE MHP15J AERIAL WORK PLATFORM
IS NOT ELECTRICALLY INSULATED.**

If the platform, booms, or any other conductive part of a MHP15J contacts a high-voltage electrical conductor, the result can be **SERIOUS INJURY** or **DEATH** for persons on or near the machine.



**GO NO CLOSER THAN THE MINIMUM SAFE APPROACH DISTANCES
(M.S.A.D) - AS OUTLINED IN TABLE 1. AND FIGURE 3.,
ON THE NEXT PAGE.**

Be sure to allow for sag and sway in the wires and the work platform.

If a MHP15J comes in contact with a live electrical conductor, the entire machine can be charged.

If that happens, you should remain on the machine and not contact any other structure or object within reach. That includes the ground, adjacent buildings, poles, and any object not a part of the MHP15J.

Such contact could make your body a conductor to the other object creating an electrical shock hazard resulting in **SERIOUS INJURY** or **DEATH**.

DO NOT attempt to enter or leave the MHP15J until you are sure the electricity has been turned off.

If a MHP15J is in contact with a live conductor, the platform operator **MUST** warn others on the ground in the vicinity of the MHP15J to **STAY AWAY** from the machine, since their bodies can also form a path for electricity to ground thus creating an electrical shock hazard with possible **ELECTROCUTION** and **DEATH**.

DO NOT attempt to operate the MHP15J ground controls when the platform, booms, or any other conductive part of a MHP15J is in contact with electrical wires or if there is an immediate danger of such contact.

Regard all conductors as energized.

Personnel working on or near a MHP15J must be continuously aware of electrical hazards, recognizing that **SERIOUS INJURY** or **DEATH** can result if contact with an electrical wire does occur.

Electrical Hazard

■ Minimum Safe Approach Distance

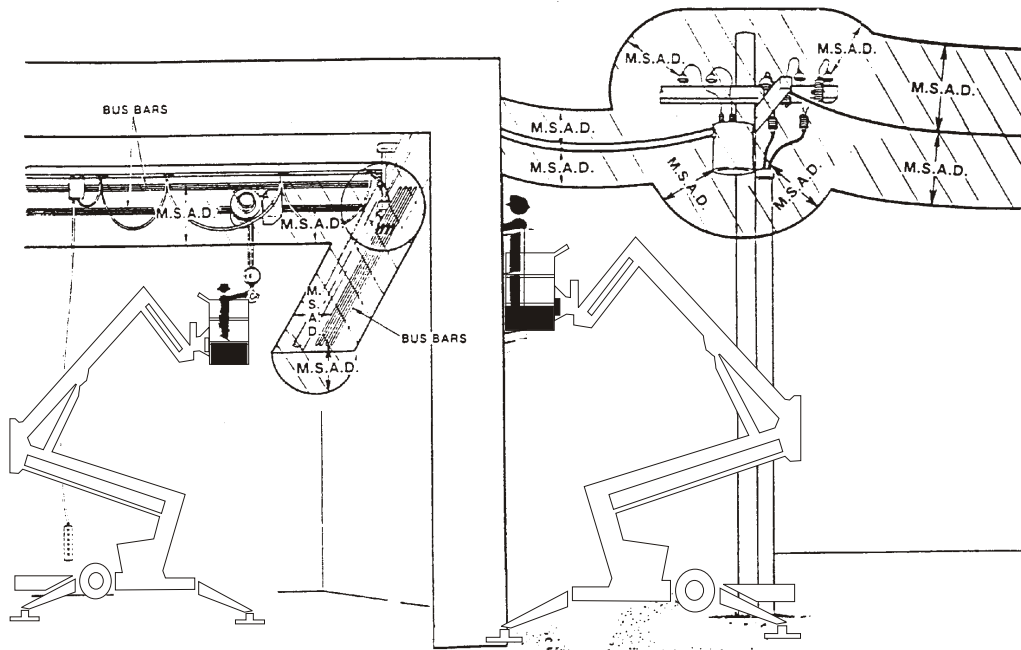
The MHP15J is an all metal boom, **NOT ELECTRICALLY INSULATED**, aerial work platform. **DO NOT** operate it near **ELECTRICAL** conductors. Regard all conductors as being energized. Use the table and illustration below to determine safe clearance from electrical conductors. (Table 1 and Figure 3, below, are from ANSI/SIA A92.5–1992 Standard, reprinted with permission of Scaffold Industry Association.)

□ Table 1 - (M.S.A.D.)

**Minimum Safe Approach Distance
to energized (exposed or insulated power lines)**

Voltage range (phase to phase)	Minimum safe approach distance	
	(Feet)	(Meters)
0 to 300V	Avoid contact	
over 300v to 50kv	10	3.05
over 50kv to 200kv	15	4.60
over 200kv to 350kv	20	6.10
over 350kv to 500kv	25	7.62
over 500kv to 750kv	35	10.67
over 750kv to 1000kv	45	13.72

□ Figure 3 - (M.S.A.D.)



Denotes prohibited zone

- Danger:**
- Do not allow machine personnel or conductive materials inside prohibited zone.
 - Maintain M.S.A.D. From all energised lines and parts as well as those shown.
 - Assume all electrical parts and wires are energised unless known otherwise.
- Caution:**
- Diagrams shown are only for purposes of illustrating M.S.A.D. Work positions, not all work positions.

The most important chapter in this manual is "Safety" chapter 1. Take time, now, to study it closely. The information in chapter 1, might save your life or prevent serious injury.

■ Signs

The following three conventions are used throughout this manual.

1. Danger sign

▲ DANGER

means: Attention! Become alert! Your safety is involved.

2. Caution sign

▲ CAUTION

means one of two things: (1) an action, about to be performed, is potentially hazardous and might result in minor personal injury if not done correctly, or (2) an action, about to be performed, can harm the MHP15J if not done correctly.

3. Note sign

NOTE

means: The information following is to assist you in either the proper steps to take for an action or as additional information concerning your present situation, but does not indicate a dangerous condition to either you or the MHP15J unit.

■ Qualified operators

The MHP15J aerial platform has built in safety features and has been factory tested for compliance with Snorkel specifications and industry standards. However, any personnel lifting device can be potentially dangerous in the hands of untrained or careless operators.

Training is vitally important and **MUST** be done under the direction of a QUALIFIED person. You must display proficiency in knowledge and actual operation of the MHP15J.

Before operation of the MHP15J you must read and understand the operating instructions in this manual as well as the decals, warnings, and instructions on the machine itself.

Before operating the MHP15J you must be AUTHORIZED by the person in charge to do so.

■ Operation rules

The following rules will help ensure the safety of personnel and help prevent needless downtime because of damaged equipment.

1. Only TRAINED and AUTHORIZED operators shall be permitted to operate the equipment.
2. All manufacturer's operating instructions and safety rules and all employers' safety rules and all OSHA and other government safety rules must be strictly adhered to.
3. Repairs and adjustments shall be made only by QUALIFIED TRAINED maintenance personnel.
4. No modification shall be made to the equipment without prior written consent of the Snorkel Engineering Department.
5. You must make a pre-start inspection of the MHP15J at the beginning of each shift. A malfunctioning machine must not be used.
6. You must make an inspection of the work place to locate possible hazards before operating the MHP15J.

▲ DANGER

DO NOT operate this equipment unless you are TRAINED and AUTHORIZED and have read and thoroughly understand all of the information given in this Operator's Manual and on all DANGER and CAUTION signs on the machine. Misuse of this machine can result in DEATH or SERIOUS INJURY.

■ Maintenance

Every person who maintains, inspects, tests, or repairs these machines, and every person supervising any of these functions, **MUST** be properly trained.

This Operator's Manual provides a daily inspection procedure that will help you keep your MHP15J in good operating condition. **DO NOT** perform other maintenance unless you are a TRAINED mechanic, QUALIFIED to work on the MHP15J. Call QUALIFIED maintenance personnel if you find problems or malfunctions.

DO NOT modify this machine without written approval from the Engineering Department of Snorkel.

Information contained in this manual concerns only current MHP15J's, and the right is reserved to make changes at any time without obligation.

Introduction

■ Responsibilities of parties

It is imperative that all owners and users of the MHP15J read, understand, and conform to all applicable regulations. Ultimate compliance to OSHA regulations is the responsibility of the employer using the equipment.

▲ DANGER

ANSI Standard A92.2-1992 clearly identifies requirements of all parties who might be involved with Boom-Supported Elevating Work Platforms.

AUSTRALIAN / NZ STANDARD 2550-10 1994 Also identifies the requirements of all parties who might be involved with Boom-Supported Elevating Work Platforms.

A reprint of the “Manual of Responsibilities for Dealers, Owners, Users, Operators, Lessors and Lessees of ANSI/SIA A92.5-1992 Boom Supported Elevating Work Platforms” is available from Snorkel dealers or from the factory upon request.

Copies are also available from the Scaffold Industry Association, Inc., 14039 Sherman Way, Van Nuys, CA 91405-2599.

■ Options

The use of optional equipment is discussed in the “Options” chapter 11.

The options you will find discussed there are:

1. Air line to platform.
2. Dual fuel.
3. Work lights.
4. Sandblast protection kit.
5. RCD/ELCB AC outlet.
6. Flashing light.
7. Platform rotator.
8. Self levelling stabilisers.

■ Additional information

For additional information, contact your local dealer.

Snorkel
2/26 Redfern Street
Wetherill Park NSW 2164
Australia

Snorkel
PO Box 1041
Levin 5500
New Zealand

Electrical Hazard

Electrical Hazard Warning i
 Minimum Safe Approach Distance ii
 Table 1 - (M.S.A.D.) ii
 Figure 3 - (M.S.A.D.) ii

Introduction

Signs iii
 Qualified operators iii
 Operation rules iii
 Maintenance iii
 Responsibilities of parties iv
 Options iv
 Additional information iv

1. Safety

Safe Operation 1-1
 Pre-start Inspection 1-1
 Work Place Inspection and Practices 1-1
 Electrocution 1-1
 Tipover and Falling Hazards 1-1
 Crushing 1-2
 General Safety Precautions 1-2
 Personnel Precautions 1-2
 Operator General Precautions 1-2
 Mounting and Dismounting Precautions 1-2
 Starting and Stopping Precautions 1-2
 Operating Precautions 1-2
 Operator Maintenance Precautions 1-3
 Fuel Handling Precautions 1-3
 Safety Decals and Placards 1-3
 Safety Placards and Decals Location 1-4

2. Safety Devices

Safety Device Information 2-1
 Emergency Stop Switches 2-1
 At ground control box 2-1
 At platform control box 2-1
 Other Safety Devices 2-1
 Lanyard anchor points 2-1
 Gravity gate 2-2
 Guardrails 2-2
 Foot switch 2-2
 Bubble level 2-2
 RCD/ELCB AC outlet 2-3
 Flashing light 2-3

3. Specifications

General Specifications 3-1
 Engine Data 3-2
 Overall Dimensions MHP15J 3-2
 Working Envelope - MHP15J 3-3
 Booms identification 3-4

Nomenclature And Serial Numbers 3-4
 Right side view of machine 3-4
 Left side view of machine 3-5

4. Gauges

Hourmeter 4-1
 Level Bubble 4-1
 Hydraulic Oil Level 4-1

5. Shut-offs and Circuit Breakers

RCD/ELCB Outlet (option) 5-1
 Main Circuit Breaker 5-1
 Stabilisers 5-1

6. Controls

Controls Description 6-1
 Controls and Control Decals Locations 6-1
 Ground Control Box 6-2
 Ground Control Box Controls 6-3
 Platform Control Box 6-4
 Platform Control Box Controls 6-5

7. Pre-operational Inspection

Pre-operational Inspection Table 7-1
 Engine Cover 7-2
 Engine Fuel Level 7-2
 Fuel Tank Cap 7-2
 Fuel Leaks 7-2
 Engine Oil Level 7-2
 Wiring Harnesses 7-3
 Battery Terminals 7-3
 Battery Fluid Level 7-3
 Hydraulic Oil Level 7-3
 Hydraulic Oil Leaks 7-3
 Bolts and Fasteners 7-4
 Wheels and Tyres 7-4
 Structural Damage and Welds 7-4
 Lanyard Anchor Points 7-5
 Platform Gravity Gate 7-5
 Platform Guardrails 7-5
 Flashing Light (option) 7-6
 Ground Control Switches 7-6
 Emergency Lower 7-6
 Lower control box 7-6
 Upper control box 7-6
 Platform Control Switches 7-7
 AC Outlet RCD/ELCB (option) 7-7
 Placards and Decals 7-8
 Standard placards and decals 7-8
 Inspection drawing 7-9

8. Operation

Operating Procedures 8-1

Table of Contents

Control Stations	8-1
Emergency Stopping	8-1
Operation Considerations	8-1
Starting From Ground Control Box	8-2
Stabiliser Operation	8-2
Standard manual stabiliser operation	8-2
Setting the manually operated stabilisers	8-2
Raising the manually operated stabilisers	8-3
Self levelling stabilisers (Optional)	8-3
Setting the 'self levelling' stabilisers	8-3
Raising the 'self levelling' stabilisers	8-3
Setting the 'self levelling' stabilisers manually	8-3
Raising the 'self level' stabilisers manually	8-4
Starting From Platform Control Box	8-4
Moving The Platform	8-5
From Ground Control Box	8-5
From Platform Control Box	8-6
Securing for Day	8-7

9. Emergency Operation

Emergency Operation Procedures	9-1
Operation From Platform Control Box	9-1
Operation From Ground Control Box	9-2

10. Stowing and Transporting

Stowing	10-1
The correct stowed position is shown here	10-1
Transporting	10-1
Trailing	10-1
Upper boom latch	10-1
Lower boom lock pin	10-1
Securing to a Transport Vehicle	10-2
Towing	10-2
Forklift points	10-2

11. Options

Air Line To Platform	11-1
Dual Fuel	11-1
Work Lights	11-1
Flashing Light	11-1
RCD/ELCB AC Outlet	11-1
Sandblast Protection Kit	11-1
Platform Rotator	11-1
Self Levelling Stabiliser	11-1

12. Fire Fighting and Chemical Control

Hazardous Components	12-1
Battery, Lead/Acid (UN 2794)	12-1
Gasoline (UN 1203)	12-2
Hydraulic Oil (UN 1270)	12-3
Motor Oil (UN 1270)	12-3

13. Operator's Troubleshooting

Troubleshooting	13-1
Operator Troubleshooting Chart	13-1

■ Safe Operation

The following safety information is vitally important for safe operation of the MHP15J. Failure to follow these instructions can result in personal injury or **DEATH**.

□ Pre-start Inspection

At the start of each work shift, the MHP15J shall be given a visual inspection and function test. See the “Pre-operational Inspection” chapter 7, in this manual for a list of items to inspect and test.

▲ CAUTION

DO NOT operate the MHP15J unless you are trained and authorized, understand the operation characteristics of the MHP15J, and have inspected and tested all functions to be sure they are in proper working order.

□ Work Place Inspection and Practices

Do not use the MHP15J as a ground for welding. Ground to the work piece.

Before the MHP15J is used, and during use, check the area in which the MHP15J is to be used for possible hazards such as, but not limited to:

1. Drop-offs or holes.
2. Side slopes.
3. Bumps and floor obstructions.
4. Debris.
5. Overhead obstructions and electrical conductors.
6. Hazardous locations.
7. Inadequate surface and support to withstand all load forces imposed by the aerial platform in all operating configurations.
8. Wind and weather conditions.
9. Presence of unauthorized persons.
10. Other possible unsafe conditions.

Before the MHP15J is used, determine the hazard classification of any particular atmosphere or location according to ANSI/NFPA 505-1987.

Any MHP15J operated in a hazardous location must be approved and of the type required by ANSI/NFPA 505-1987.

A recommended safety practice is to have personnel that are trained in the operation of the emergency controls working in the immediate area of the MHP15J to assist the platform operator in the event of an emergency.

When moving the platform, check the clearance around the MHP15J to avoid contact with structures or other hazards. Always look in the direction of motion.

Keep ground personnel from under the platform when the platform is raised.

Secure all accessories, containers, tools, and other materials in the platform to prevent them from accidentally falling or being kicked off the platform.

DO NOT engage in any form of “horseplay” or “stunt driving” while operating the MHP15J.

DO NOT permit riders on the machine anyplace other than on the platform.

Remove all loose objects stored in or on the machine, particularly in the platform. Remove all objects which do not belong in or on the machine.

When other moving equipment is in the area, take special precautions to comply with local regulations regarding warnings.

Never steady the platform by positioning it against another platform.

DO NOT operate an MHP15J that is not functioning properly, or has been damaged, until the machine has been repaired by a qualified maintenance person.

DO NOT operate a MHP15J that does not have all its decals and placards attached and legible.

Watch for bystanders and never allow anyone to be under, or to reach through, the machine and its equipment while operating.

Use the recommended transport device when loading the machine.

□ Electrocutation

The MHP15J is an all metal boom, NON-INSULATED, aerial work platform.

DO NOT operate it near ELECTRICAL conductors. Regard all conductors as being energized.

DO NOT operate outside during a thunderstorm.

□ Tipover and Falling Hazards

DO NOT operate the MHP15J from a position on trucks, trailers, railway cars, floating vessels, scaffolds, or similar equipment unless the application is approved in writing by Snorkel.

If the platform or elevating assembly becomes caught, snagged, or otherwise prevented from normal motion by an adjacent structure or other obstacles such that control reversal does not free the platform, remove all personnel from the

1. Safety

platform before attempts are made to free the platform using ground controls.

Under normal working conditions it is best not to transfer from the platform to another structure or vice versa, unless that is the safest way to do the job. Each situation must be judged separately taking the work environment into account. The following guidelines apply:

1. Where possible, place the work platform over a roof or walking structure to do the transfer.
2. Transfer your anchorage from one structure to another before you step across.
3. Remember, you might be departing the work platform to a structure where fall arrest is required.
4. **DO NOT** climb the rails. Use the entrance.

All platform occupants **MUST** wear and use fall restraint. Attach fall restraints to the platform lanyard anchor points.

DO NOT exceed the unrestricted platform capacity as indicated on the capacity placard at the entrance to the platform.

ENSURE all four stabilizer foot plates are in firm contact with the ground as laid out on page 1-1 “Work Place Inspection and Practices”. **DO NOT** raise the boom if the MHP15J is on soft ground. Operate the boom only on a firm surface capable of withstanding all load forces imposed by the aerial work platform in all operating conditions.

Do Not carry loads from any point outside of the platform.

Care shall be taken to prevent rope, electric cords, and hoses, etc., from becoming entangled in the aerial platform.

Raise the platform only when the MHP15J is on level ground.

Maintain a firm footing on the platform floor. Climbing on the guardrails is prohibited.

DO NOT use ladders, planks, or other devices to extend or increase your work position from the platform.

DO NOT jerk the controls. Move the controls slowly and deliberately to avoid jerky and erratic operation. Always stop the controls in the neutral, off, position before going in the opposite direction.

DO NOT use the boom for any purpose other than to position personnel, their tools, and materials.

DO NOT use the MHP15J as a crane, hoist, or jack.

DO NOT operate the MHP15J in winds, or wind gusts, of 28 mph (12.5 m/s) or more.

DO NOT add anything to the MHP15J that will increase the wind loading (banners, flags, etc.).

Crushing

Always look in the direction of travel. Avoid overhead obstructions.

Never cover the floor grating or otherwise obstruct your view below.

Make sure the area below the platform is free of personnel before lowering.

General Safety Precautions

Personnel Precautions

If you encounter any suspected malfunction of the aerial platform, or any hazard or potentially unsafe condition relating to capacity, intended use, or safe operation, cease operation and seek assistance from management.

Operator General Precautions

Make sure that all protective guards, cowlings, and doors are in place and secure.

Be sure the guardrail system, including the gate, is in place and secure.

Mounting and Dismounting Precautions

Use three points of support when getting on or off the platform (two hands and one foot or a similar set of points). Keep the platform clean.

DO NOT jump off the machine.

DO NOT dismount while the boom is in motion.

Starting and Stopping Precautions

DO NOT start until all personnel are clearly away from the machine.

Before leaving the operator’s station, place the machine in the stowed position.

When leaving the machine parked or unattended, remove the starter key from the **Master Key Switch**.

Operating Precautions

DO NOT modify the MHP15J in any way.

When parts or components are replaced, they shall be identical or equivalent to original Snorkel parts or components.

DO NOT override any of the safety features of the MHP15J.

❑ Operator Maintenance Precautions

▲CAUTION

DO NOT use your hand to search for hydraulic oil leaks. High pressure hydraulic oil can easily cut and penetrate your skin — a very serious injury that requires immediate attention by a medical specialist trained in that type of injury. Use a piece of cardboard or wood to search for hydraulic oil leaks.

DO NOT attempt repairs unless you are trained. Refer to manuals and experienced repair personnel for help.

❑ Fuel Handling Precautions

DO NOT smoke or permit open flames while fueling or near fueling operations.

Never remove the fuel cap or refuel a gasoline engine while the engine is running or hot. Never allow fuel to spill on hot machine components.

Maintain control of the fuel filler nozzle when filling the tank.

DO NOT fill the fuel tank to capacity. Allow room for expansion.

Clean up spilled fuel immediately.

Tighten the fuel tank cap securely. If the fuel cap is lost, replace it with an approved cap from Snorkel. Use of a non-approved cap without proper venting may result in pressurization of the tank.

Never use fuel for cleaning purposes.

For diesel engines, use the correct fuel grade for the operating season.

■ Safety Decals and Placards

There are several safety decals and placards on the MHP15J. Their locations and descriptions are shown in this section. Take time to study them.

▲CAUTION

Be sure that all the safety decals and placards on the MHP15J are legible. Clean or replace them if you cannot read the words or see the pictures. Clean with soap & water and a soft cloth. Do not use solvents.

You MUST replace a decal or placard if it is damaged, missing, or cannot be read. If it is on a part that is replaced, make sure a new decal or placard is installed on the replaced

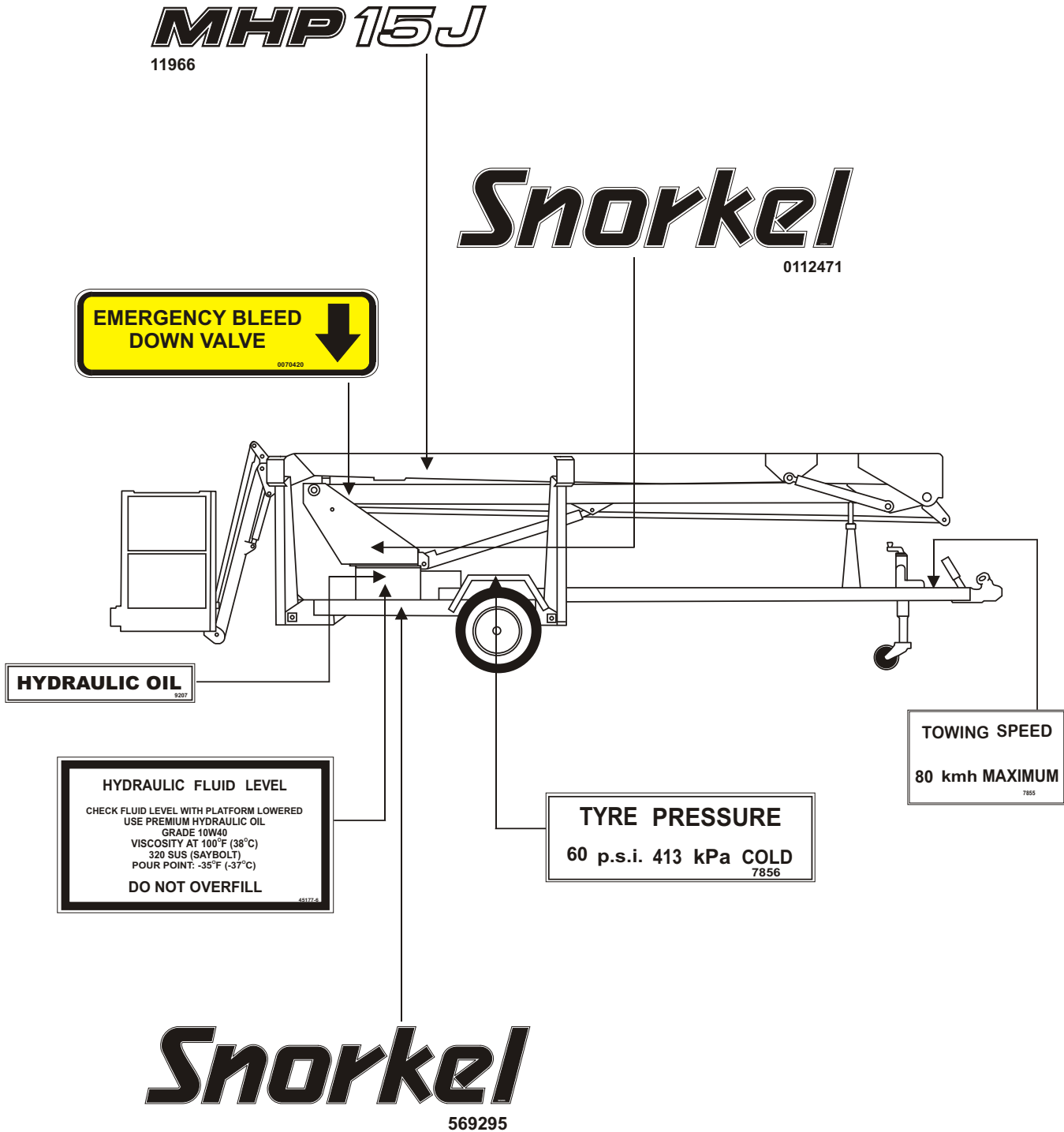
part. See your Snorkel dealer for new decals and placards.

NOTE

Refer to Placards and Decals Inspection Chart and Drawing in the “Pre-operational Inspection” chapter 7, for part numbers, location, and required quantities of all placards and decals.

1. Safety

■ Safety Placards and Decals Location



OPERATORS CHECKLIST

INSPECT AND/OR TEST THE FOLLOWING DAILY OR AT THE BEGINNING OF EACH SHIFT

1. OPERATING AND EMERGENCY CONTROLS.
2. SAFETY DEVICES.
3. PERSONAL PROTECTIVE DEVICES.
4. HOSES, FITTINGS AND VALVES FOR LEAKS.
5. CABLES AND WIRING HARNESS.
6. LOOSE OR MISSING PARTS.
7. TYRES AND WHEELS.
8. PLACARDS, WARNINGS, CONTROL MARKINGS AND OPERATING MANUAL(S).
9. GUARDRAIL SYSTEM.
10. OIL LEVELS.
11. BATTERY FLUID LEVEL.

300699

Snorkel

0112471

MHP 15J

11966

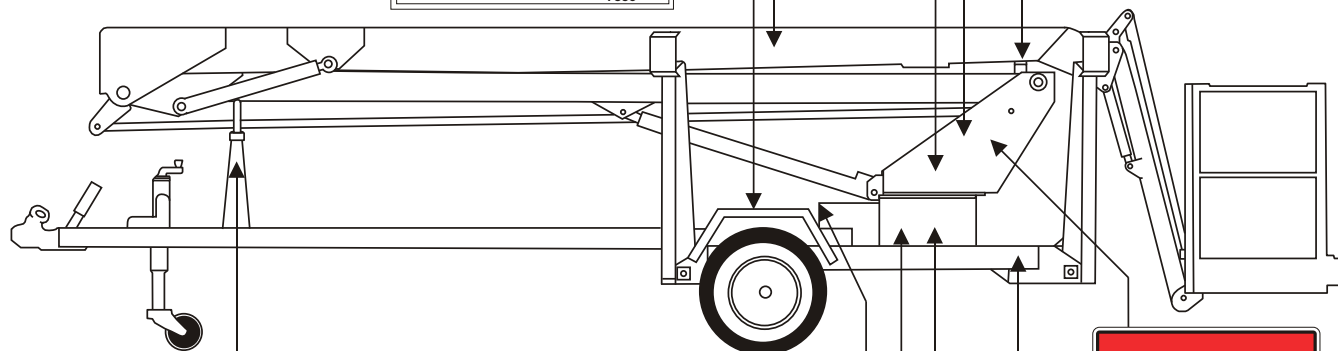
TYRE PRESSURE

60 p.s.i. 413 kPa COLD

7856

FIT BOOM CRADLE LOCK PIN FOR TRAVELLING.

1772-002K



FIT BOOM CRADLE LOCK PIN FOR TRAVELLING.

1772-002K

GASOLINE

0071923

▲ DANGER

YOU MUST NOT OPERATE THIS DEVICE UNLESS

1. YOU HAVE BEEN TRAINED IN THE SAFE OPERATION OF THIS DEVICE AND
2. YOU KNOW AND FOLLOW THE SAFETY AND OPERATING RECOMMENDATIONS CONTAINED IN THE MANUFACTURER'S MANUAL, YOUR EMPLOYER'S WORK RULES, AND APPLICABLE GOVERNMENTAL REGULATIONS.

AN UNTRAINED OPERATOR SUBJECTS HIMSELF AND OTHERS TO DEATH OR SERIOUS INJURY.

Snorkel

THIS TRAILER WAS MANUFACTURED TO COMPLY WITH THE INDICATED DESIGN CODES.

MODEL	MHP	SWL		SERIAL NUMBER	
DATE OF MANUFACTURE		VIN NUMBER			
GROSS TRAILER MASS	1700 KG	AXLE LOAD CAPACITY		2000 KG	
TYRE SIZE	185R 14 LT	RIM SIZE		6 x 14	
RECOMMENDED COLD INFLATION PRESSURE	415 KPA				

THE TYRES FITTED TO THIS VEHICLE SHALL HAVE A SPEED CATEGORY NOT LESS THAN "L" (120 KM/H)

THE SUM OF THE LOAD CARRYING CAPACITIES OF THE TYRES FITTED TO ANY AXLE OR AXLE GROUP OF THIS VEHICLE SHALL NOT BE LESS THAN THE RELEVANT LOAD SHOWN ABOVE.

9972

36 BRUCE ROAD, LEVIN, NEW ZEALAND DESIGN CODES EN280 AS 1418.10

Snorkel

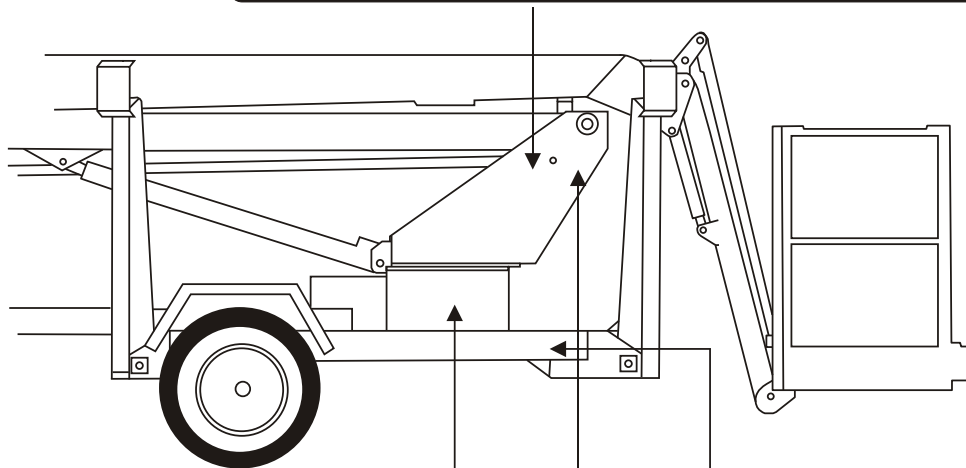
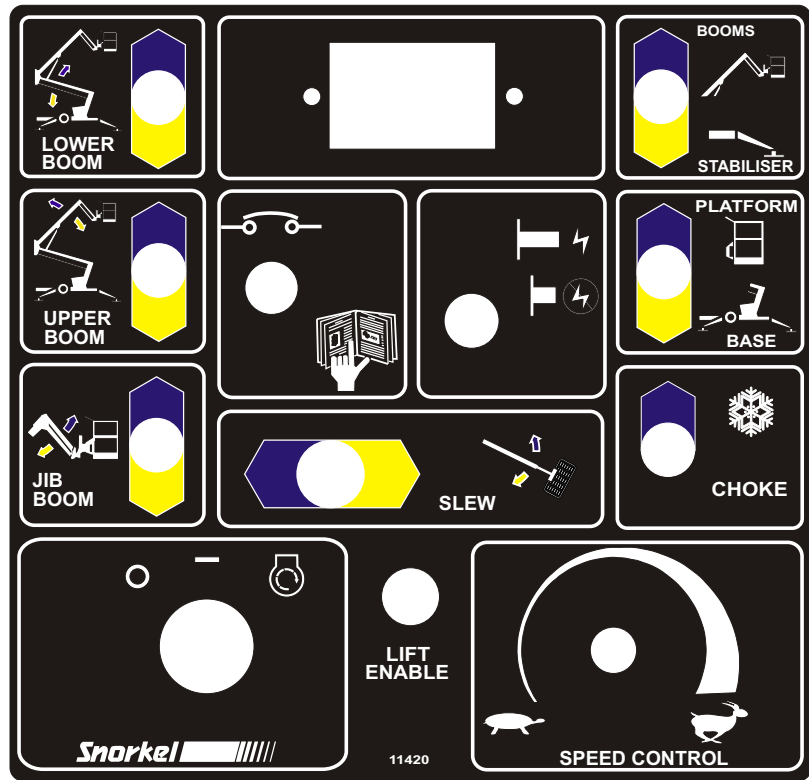
569295

▲ WARNING

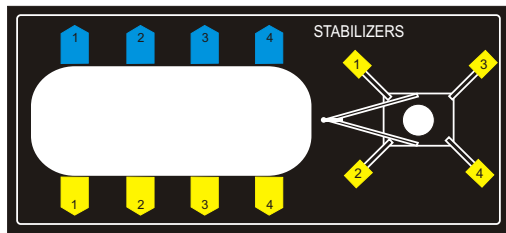
- Death or serious injury could occur from tipover.
- All outriggers must be extended onto firm level surface before elevating or before entering platform.
- Do not exceed platform capacity.

0130025

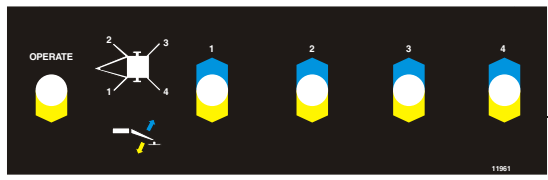
1. Safety



V.I.N. 8945



11985 - If Manual Stabilisers Fitted



11961 - If Automatic Stabilisers Fitted

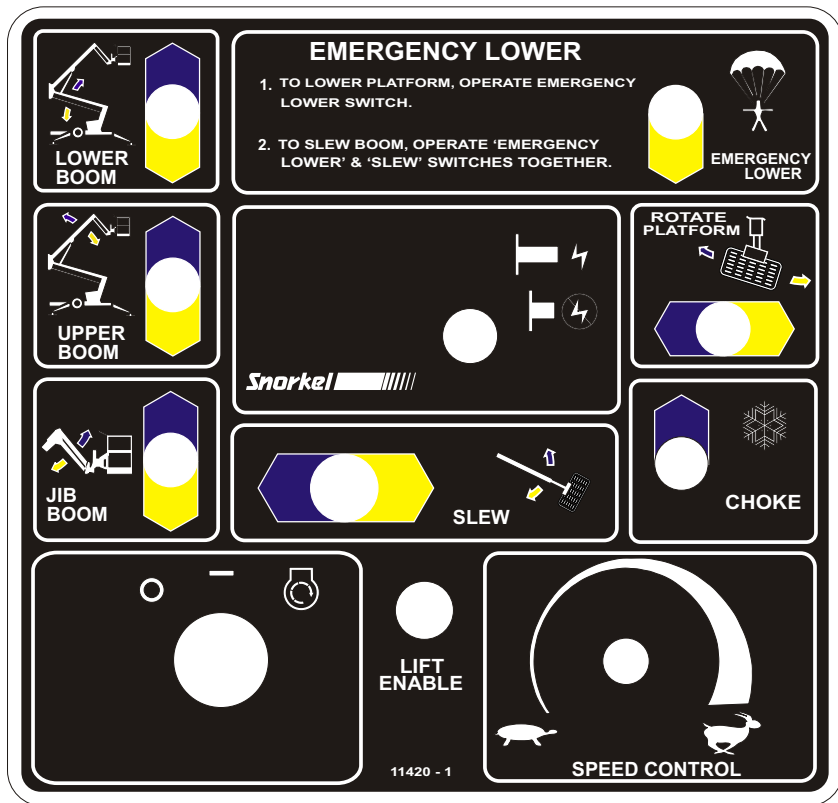
⚠ DANGER

ELECTROCUTION HAZARD

THIS MACHINE IS NOT ELECTRICALLY INSULATED.

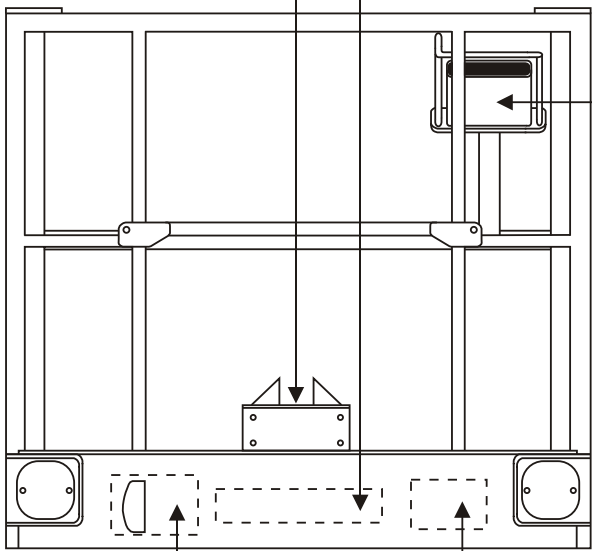
- Death or serious injury can result from contact or inadequate clearance to electrical power lines and apparatus.
- Maintain 10 feet minimum clearance from electrical power lines and apparatus.
- Allow for sway, rock, and sag.

0323899



SWL 200 KG

Attach lanyard of fall restraint to loop below



DANGER

BEWARE OF ELECTRICAL HAZARDS

REGULATION 133A OF THE CONSTRUCTION SAFETY ACT 1912 REQUIRES

- (a) Minimum approach of an appliance to live electrical apparatus. — 3m. for voltages up to 132,000
- (b) Inspection of the work site for electrical hazards before commencing to use the appliance. — 6m. for voltages above 132,000 and up to 330,000
- (c) Constant vigilance and an observer required whilst working or travelling the appliance in the vicinity of live electrical apparatus. — 8m. for voltages above 330,000

(Australia Only)

CAUTION

SAFETY BELTS WITH SHOULDER STRAPS OR SAFETY HARNESS ARE TO BE USED

WARNING

KEEP CLEAR OF POWER LINES

Unless the Electrical Supply Authority has advised in writing otherwise; the clearance between any live overhead power line and any part of this machine or load carried is required by law to be **AT LEAST 4 METRES**

This is a requirement of regulation 93 of the Electrical Supply Regulations 1984 in the interests of safe working.

(New Zealand Only)

1. Safety

■ Safety Device Information

For emergency operation controls and procedures, see the “Emergency Operation” chapter 9, in this manual.

The devices listed in this chapter are safety devices.

They are on the MHP15J to increase safety in the work place for both the operator and other people near the MHP15J.

▲ CAUTION

DO NOT by pass, disable, modify, or ignore any of these devices. Check them carefully at the start of each work shift to see that they are in working order (see “Pre-operational Inspection” chapter 7). If any is found to be defective, remove the MHP15J from service immediately until a qualified service technician can make repairs.

■ Emergency Stop Switches

□ At ground control box



Figure 2.1 - Emergency Stop Switch at Ground Control Box

Press the **EMERGENCY STOP** switch cover down, at any time, under any conditions and the entire machine stops, and nothing moves. This emergency stop switch cover must be up and the switch turned on for anything on the MHP15J to work.

□ At platform control box

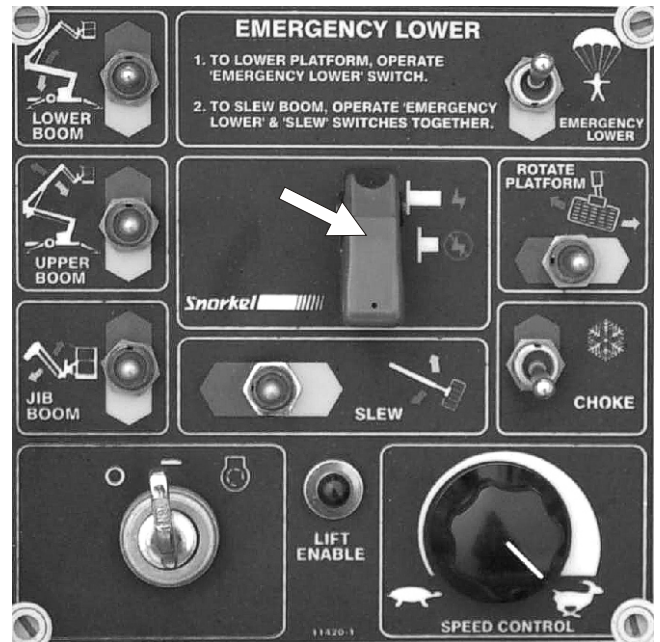


Figure 2.2 - Emergency Stop Switch at Platform Control Box

Press the **EMERGENCY STOP** switch cover down, at any time, under any conditions and the entire machine stops, and nothing moves. This emergency stop switch cover must be up and the switch turned on for anything on the MHP15J to work.

NOTE:

The ground control box is designed to override the platform control box. If the platform control box **EMERGENCY STOP** switch is down (off) the ground control box can still be used to start and operate the MHP15J.

■ Other Safety Devices

□ Lanyard anchor points

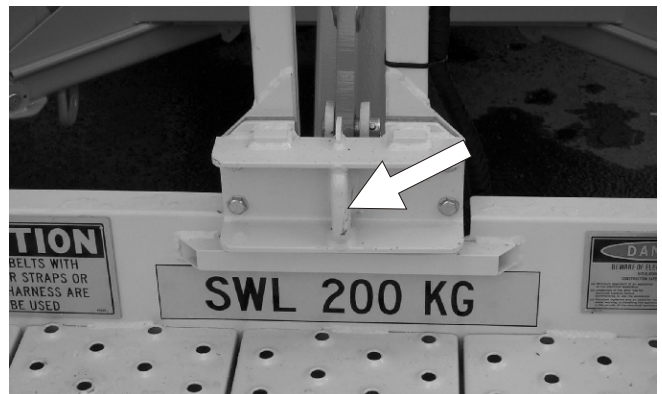


Figure 2.3 - Lanyard Anchor Points

2. Safety Devices

All personnel on the platform should attach their fall restraint lanyards to one of the lanyard anchor points.

Gravity gate



Figure 2.4 - Gravity Gate

The gravity gate is the place in the platform guard-rail system where you should enter and leave the platform. Raise the gate and step under it onto the platform. Once you have entered the platform and attached your fall restraint lanyard to an anchor point, check to see that the gravity gate has fallen back into place.

Guardrails



Figure 2.5 - Guardrails

The guardrails help protect you from falling off the platform. Be sure the guardrails are properly installed and that the gravity gate or swinging gate is in place.

Foot switch

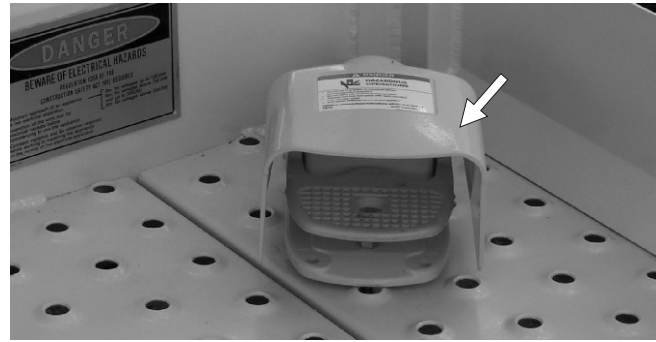


Figure 2.6 - Foot Switch

The foot switch prevents the platform from moving if something accidentally pushes one of the platform-moving controls on the platform control box. Stepping on the foot switch is an action that must be performed, at the same time as another action, to make the platform move.

Bubble level

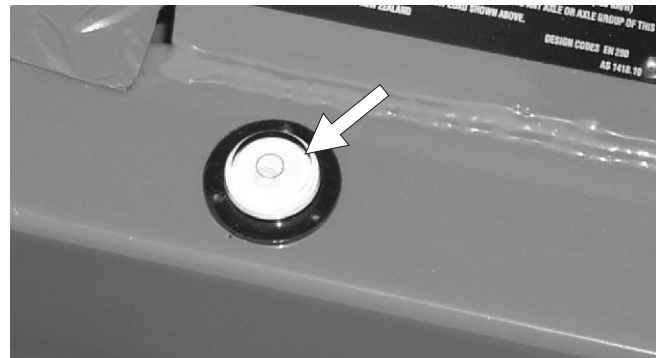


Figure 2.7 - Bubble Level

A bubble level is located on the trailer side rail, beside the outrigger controls. Watch the bubble level while you set the stabilisers. Lower the stabilisers, one at a time, just enough to center the bubble in the circle on top of the gauge. When the bubble is centered the platform is level and can be safely raised.

❑ RCD/ELCB AC outlet

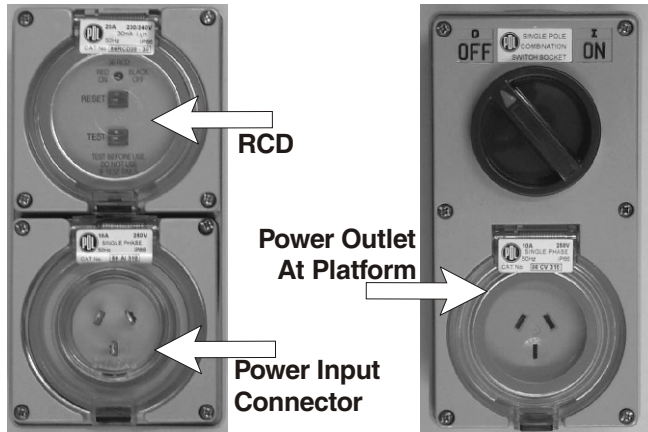


Figure 2.8 - RCD/ELCB AC Outlet

The RCD (Residual Current Device) is located at the base and will protect against short circuits to earth. When there is a short circuit the RCD will shut down the 230v AC power to the platform outlet.

To reset the outlet disconnect the power tool lead from the platform box and reset the RCD at the base.

If the problem persists call a trained service technician.

❑ Flashing light

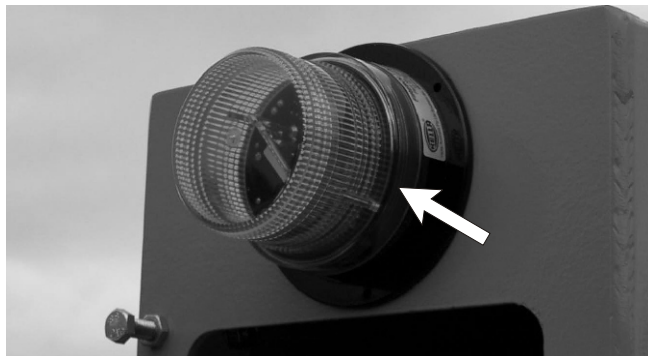


Figure 2.9 - Flashing Light

The flashing light alerts people that the MHP15J is moving. The light flashes at about one flash per second any time the MASTER KEY switch is on. There is no ON/OFF switch for the flashing light, it cannot be turned off while the MHP15J is running.

2. Safety Devices

The Snorkel MHP15J is a boom supported elevating work platform built to conform to all applicable OSHA, ANSI or CSA standards as previously outlined.

OSHA Paragraph 1910.67 Title 29, C.F.R., Vehicle-Mounted Elevating and Rotating Work Platforms - Labour.

OSHA Paragraph 1926.556 Title 29, C.F.R., Aerial Lifts - Construction.

Australian Standard AS1418-10 1996 Elevating Work Platforms.

NOTE:

For further details regarding lubricants, maintenance schedules and service please refer to the Maintenance and Repair Parts Manual for this machine.

■ General Specifications

SPECIFICATIONS	MHP15J	
Nominal working height	14.8m	48' 7"
Maximum height to basket floor	13m	42' 6"
Maximum outreach	6.8m	22' 8"
Maximum outreach height	6.90m	22' 6"
Maximum width of base		
Stabilisers retracted	1.75m	5' 7"
Stabilisers extended	3.53m	11' 5"
Safe working load (unrestricted)	200kg	440lbs
Standard colour	Orange base/boom grey platform	
Platform size	1200 x 760 x 1100mm	4' x 2' 6" x 3' 7"
	Aluminum	Aluminum
Travelling height	1.82m	5' 9"
Overall length	7553mm	25'
Maximum towing speed	80km/h	50m/h
Turntable rotation	360° continuous	
Trailer tongue weight	100kg	220lb
Maximum rated axle capacity	2000kg	4408lb
Insulation rating	Nil	
Weight	1700kg	3746lb

■ Recommended Hydraulic Oil

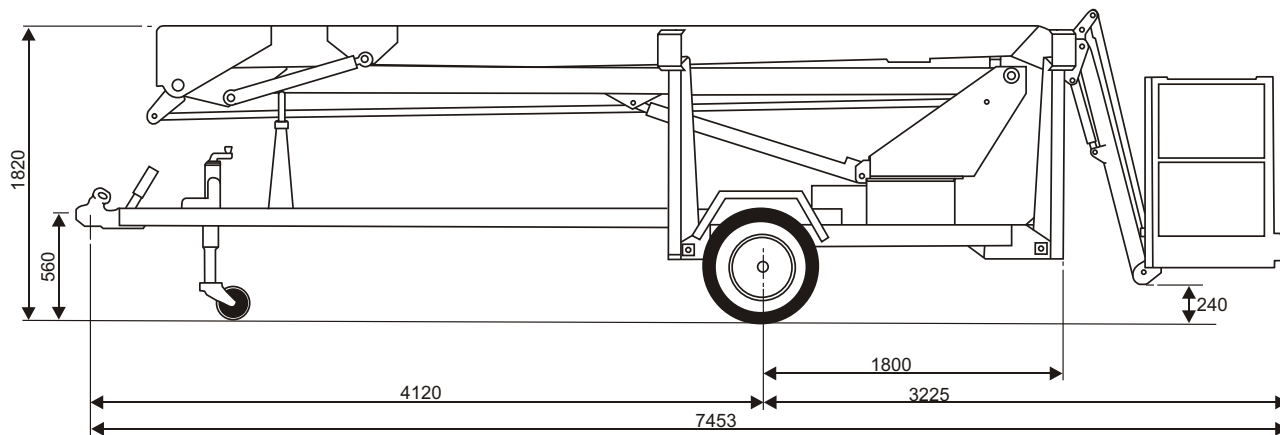
Shell Tellus 32 or Castrol AWS 32 or similar

3. Specifications

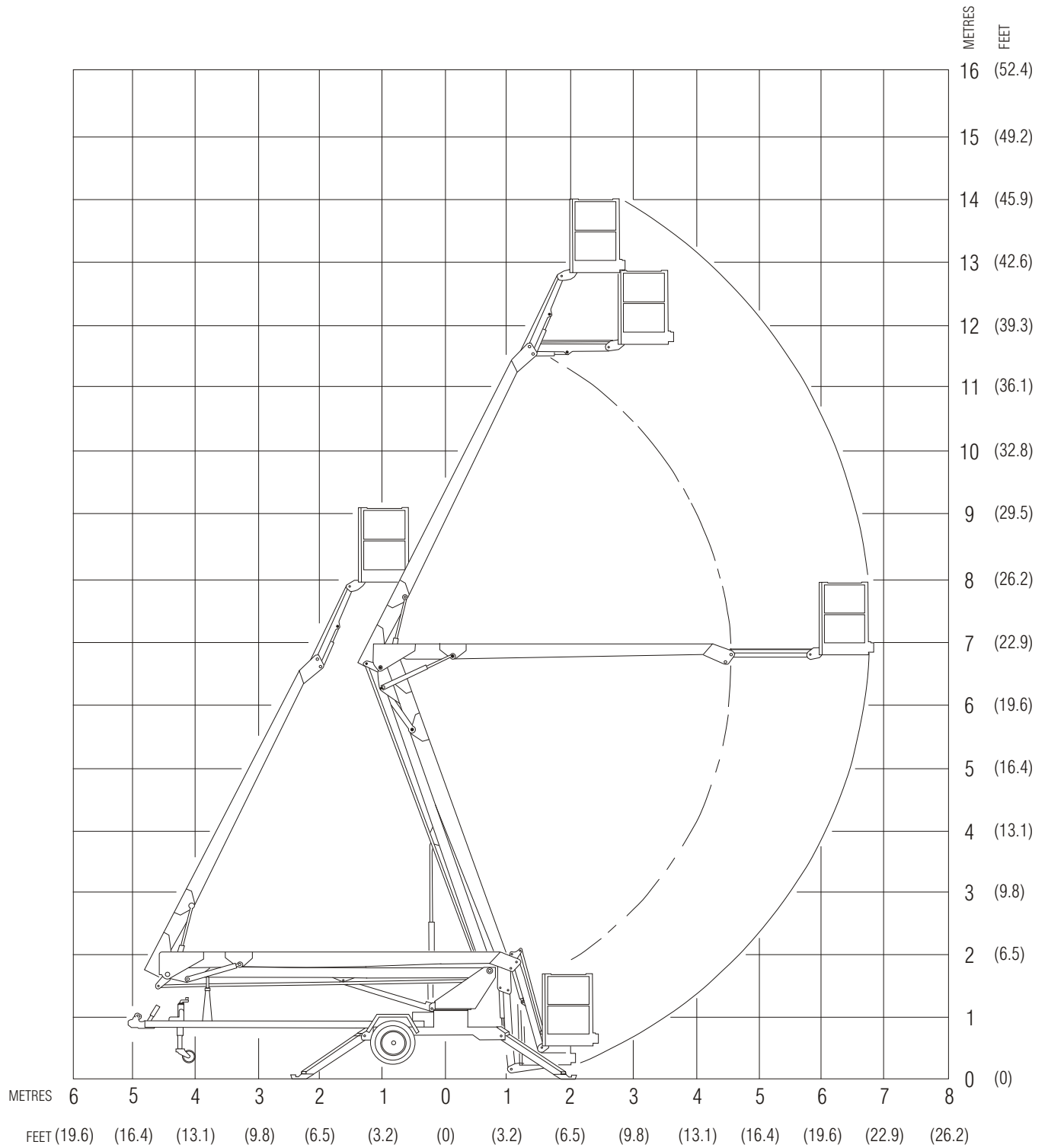
■ Engine Data

Engine Make	Honda (gasoline)
Model	GX 160
Engine type	4-stroke, over head valve, 1 cylinder
Displacement	163 cm ³ (9.9 cu-in)
Bore x Stroke	68 x 45 mm (2.7 x 1.8 in)
Max. output	4 kW/4,000 rpm
Max. torque	1.1 kg-m (8.0 ft-lb)/ 2500 rpm
Fuel	gasoline
Fuel Grade	automotive gasoline (unleaded or lowleaded preferred)
Fuel consumption	230 g/PSh
Cooling system	Forced air
Ignition system	Transistor magneto
PTO shaft rotation	Counterclockwise
Oil Capacity	0.60 litres (0.60 US qt, 0.53 Imp qt)
Oil Grade	SAE 10W-30

■ Overall Dimensions MHP15J



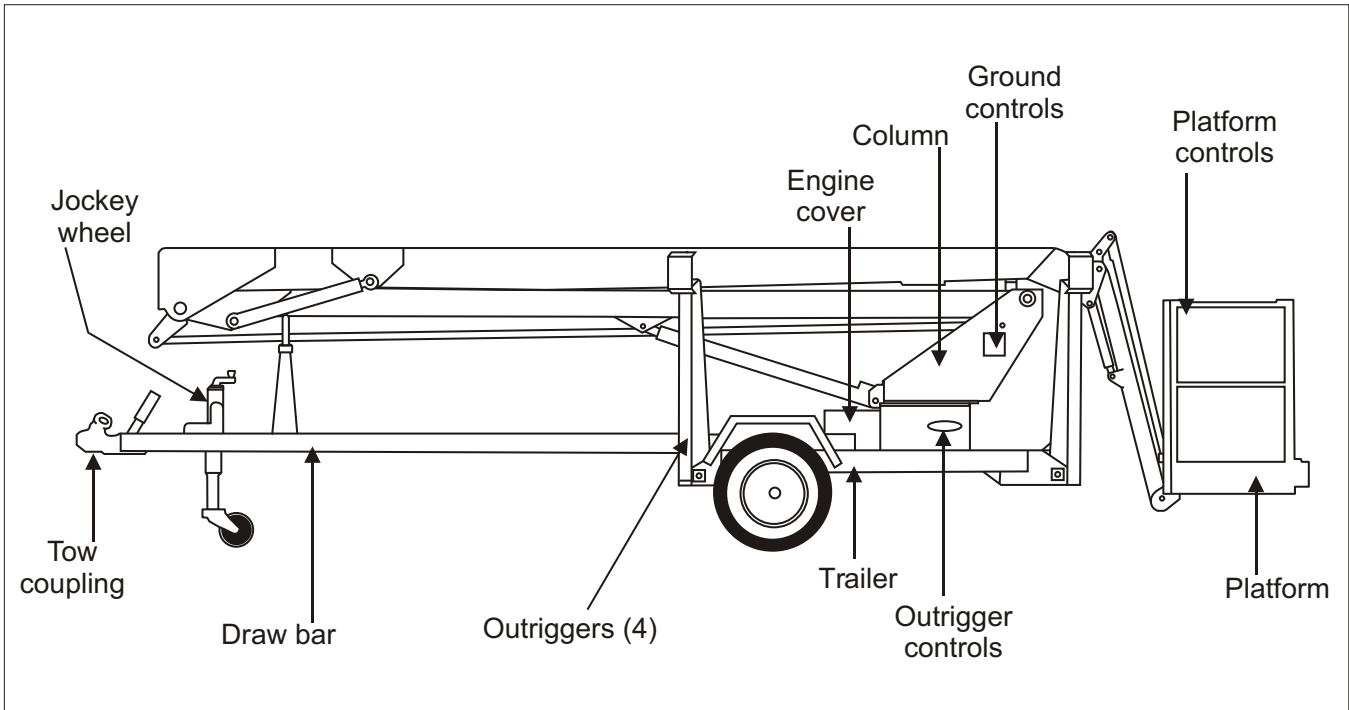
■ Working Envelope - MHP15J



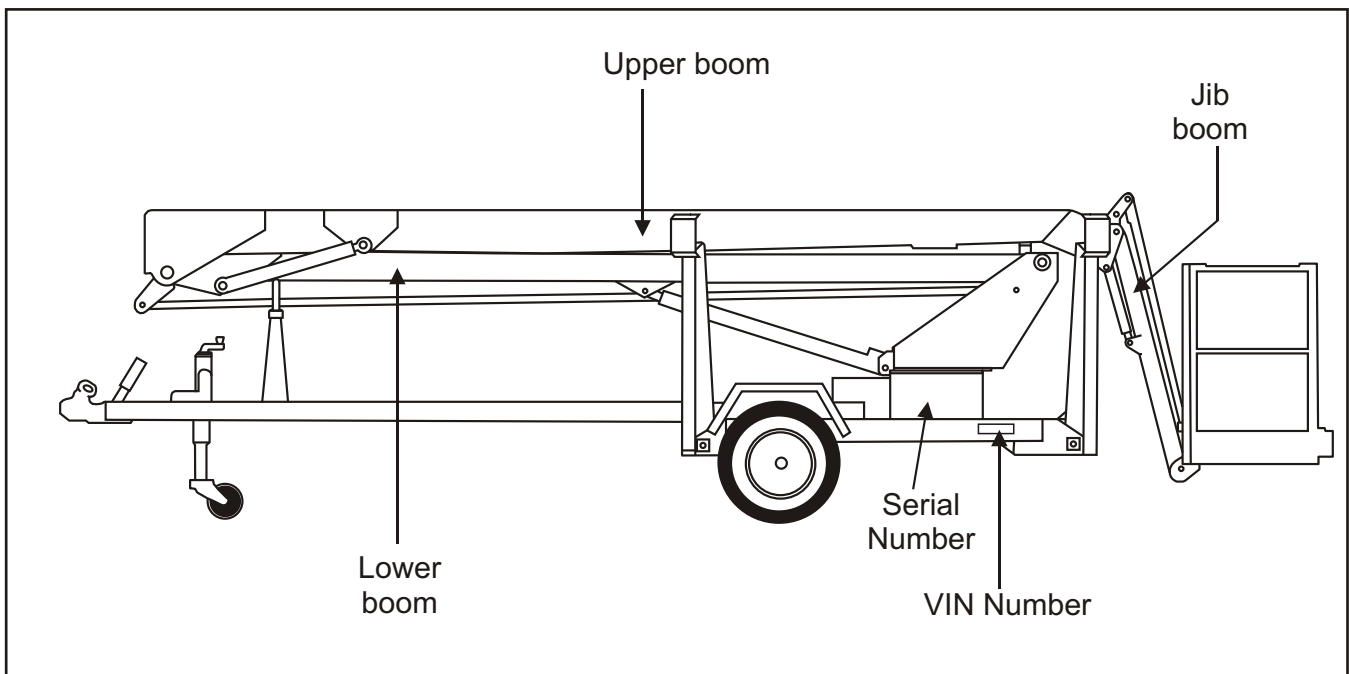
3. Specifications

■ Nomenclature And Serial Numbers

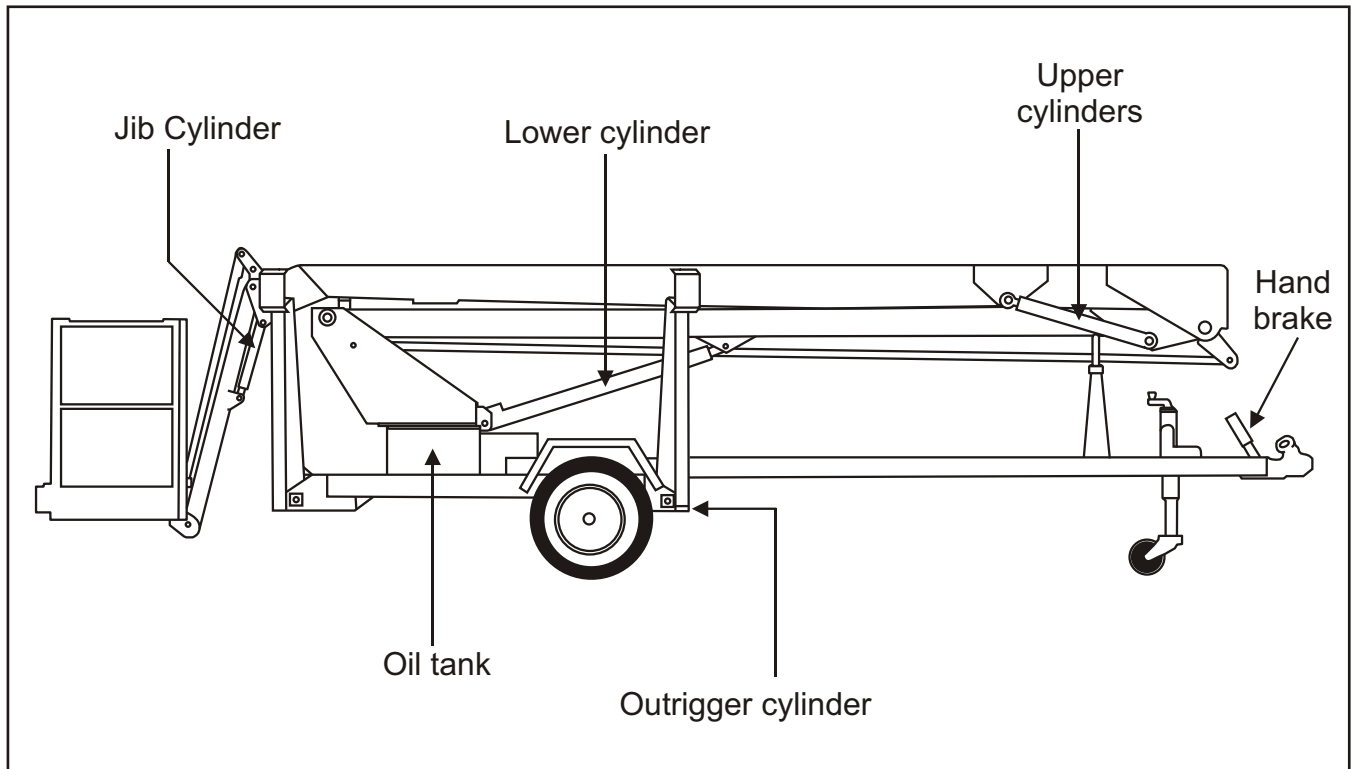
□ Right side view of machine



□ Booms identification



□ Left side view of machine



3. Specifications

■ Hourmeter

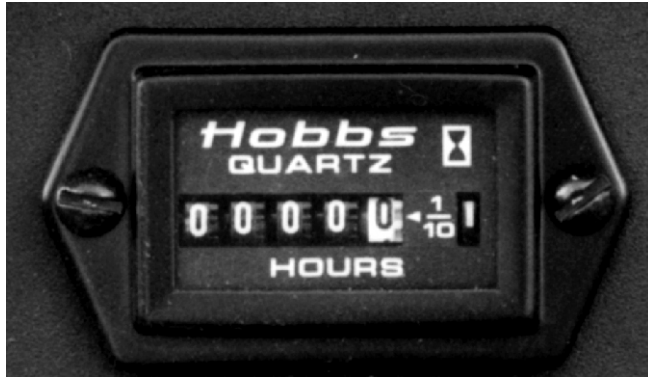


Figure 4.1 - Hourmeter

The hour meter is basically an electric clock. It accumulates time when the master key switch is turned on. The hour meter cannot be reset. An MHP qualified service technician can use it to tell when it is time for the periodic maintenance listed in the maintenance manual.

■ Level Bubble

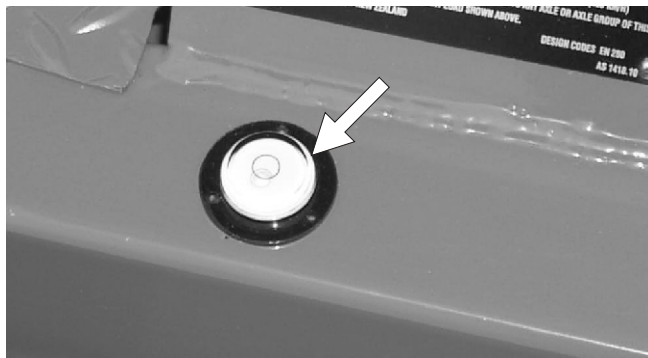


Figure 4.2 - Level Bubble

A level bubble is mounted on the trailer base. Watch the bubble while you set the stabilisers. Lower the stabilisers, front ones first, one at a time just enough to center the bubble in the circle on top of the gauge. When the bubble is central the platform is level and the platform can be safely raised.

■ Hydraulic Oil Level

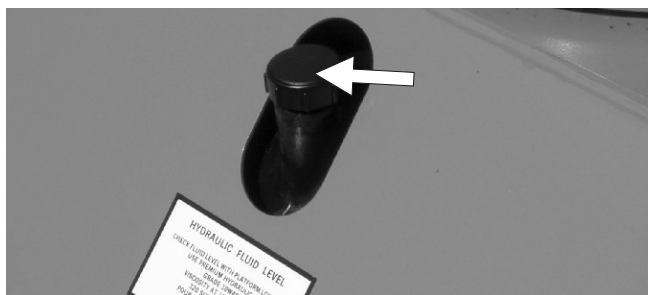


Figure 4.3 - Hydraulic Oil Level

The hydraulic oil level gauge is on the side of the hydraulic oil tank. It shows the actual level of oil inside the tank. Read it only when the booms are fully lowered and stabilisers are raised in the travel position. The oil level should be within + or - 6mm (1/4") of the line.

4. Gauges

■ RCD/ELCB Outlet (option)

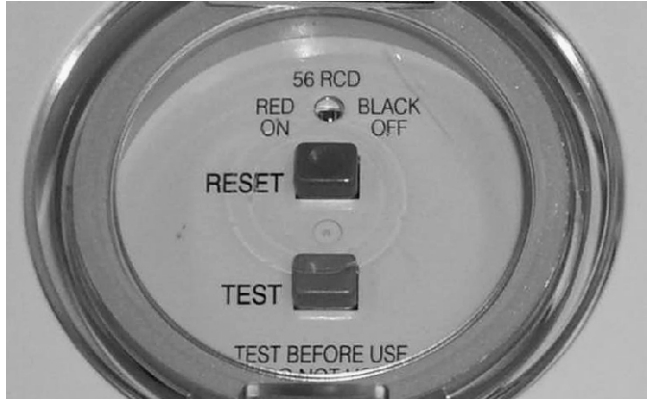


Figure 5.1 - RED/ELCB Outlet

The RCD (Residual Current Device) is located at the base and will protect against short circuits to earth. When there is a short circuit the RCD will shut down the 230v AC power to the platform outlet.

To reset the outlet disconnect the power tool lead from the platform box and reset the RCD at the base.

If the problem persists call a trained service technician.

■ Main Circuit Breaker

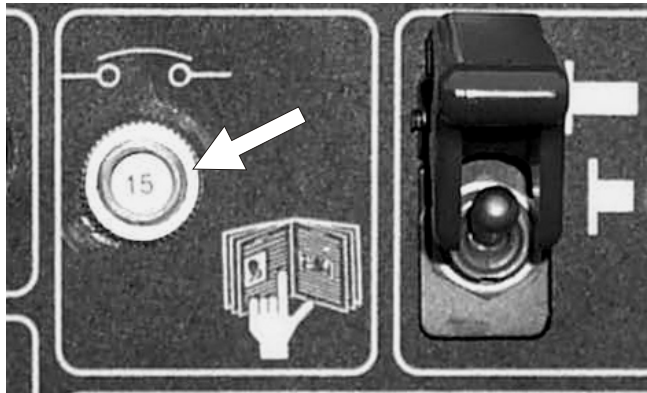


Figure 5.2 - Main Circuit Breaker

There is only one circuit breaker, on a standard MHP15J, that is accessible to the operator. Its purpose is to protect the electrical circuits from electrical overloads. When the circuit breaker trips (pops out) push it back in then attempt to use the MHP15J. If the circuit breaker trips a second time, take the MHP15J out of service and refer the problem to a qualified trained service technician for repair.

■ Stabilisers

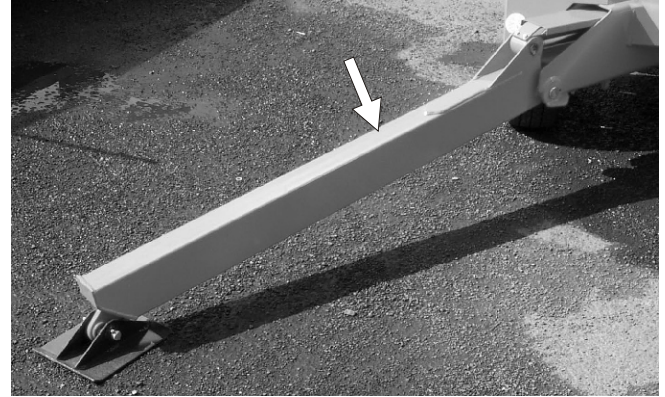


Figure 5.3 - Stabilisers

The MHP15J booms cannot be raised unless the stabilisers are set and the lift enable light on the lower control box is lit. Once the booms are raised from the stowed position the stabilisers become disabled until the booms are stowed in the travel position.

5. Shut-offs and Circuit Breakers

■ Controls Description

This chapter explains what each control does.

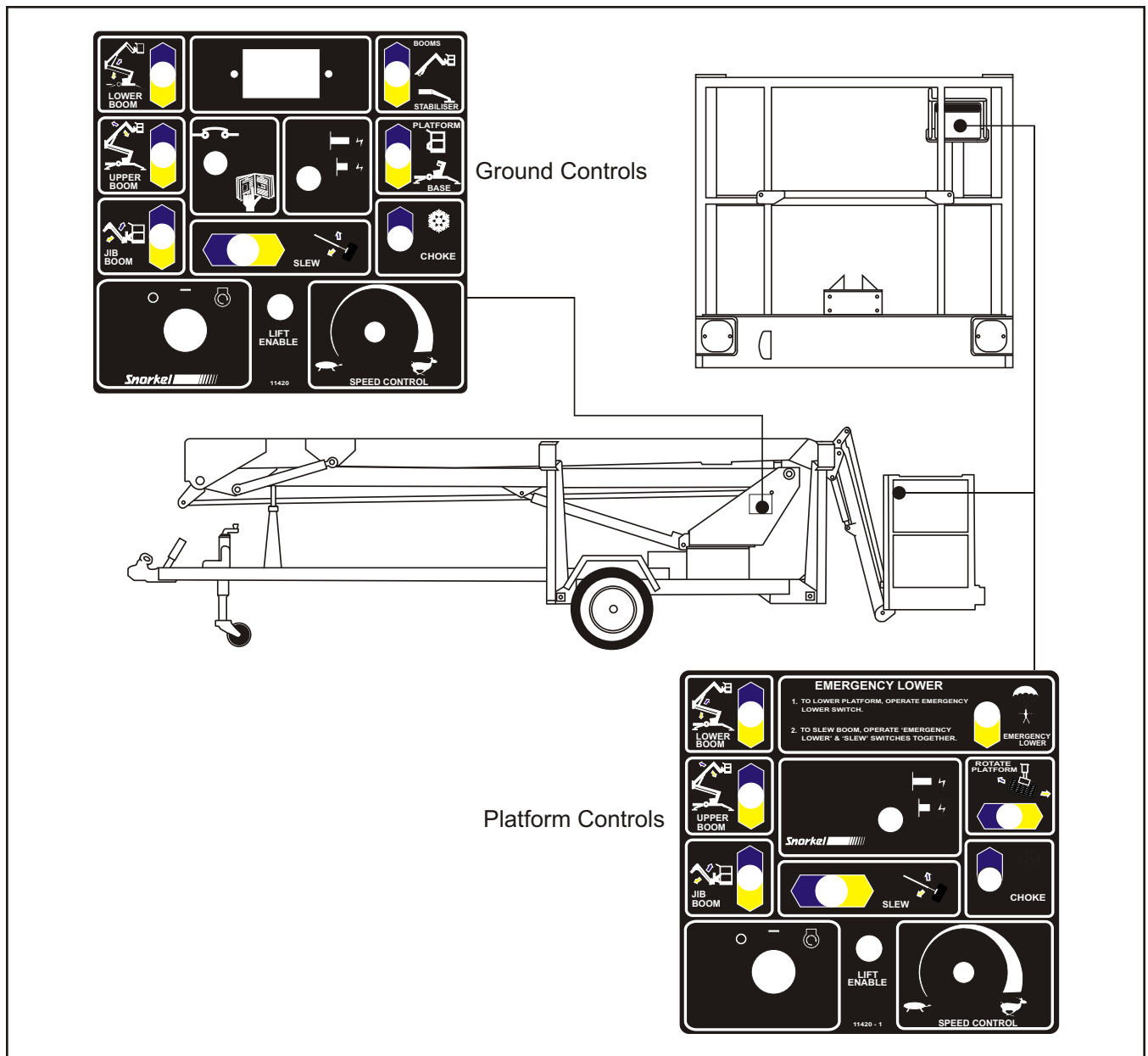
This chapter **DOES NOT** explain how to use the controls to produce useful work, refer to the “Operation” chapter 8-1 for that after you have read this chapter.

For optional equipment controls, see the “Options” chapter.11-1

See the “Emergency Operation” chapter 9-1 for the location of the emergency bleed down control and for correct emergency bleed down procedures.

The main operating functions of an MHP15J can be controlled from the ground control box or from the platform control box.

□ Controls and Control Decals Locations



6. Controls

■ Ground Control Box

Controls for operating the MHP15J from the ground, are located on the right side of the turntable.

NOTE

The number of each control below corresponds to the control's call out on the control box illustration.

1. **Emergency Stop:** Press the EMERGENCY STOP switch cover down, at any time, under any conditions, and the entire machine stops, and nothing moves. This emergency stop switch cover must be up and the switch turned on for anything on the MHP15J to work.
2. **Platform/Ground Selector :** Must be in the GROUND position (down) for the ground control box to work. The switch MUST be in the PLATFORM position (up) for the platform control box to work.
3. **Choke/Cold Start:** Hold the switch UP while you start an engine that is at ambient air temperature (a "cold" engine). This will choke the engine.
4. **Master Key Switch:** This switch works like an automobile ignition switch. Hold it at START until the engine starts, then release it to ON. (-) Turn the **Master Key Switch** to OFF (O) if the platform is to stay in one position for a long time, that will turn the engine off and save fuel.
5. **Boom Speed:** This control determines how fast the booms move. Set it to SLOW (turtle) until you are very familiar with the way the machine works or if the platform is working in dangerous or cramped surroundings.
6. **Stabliser / Boom Selector Switch:** Must be in Stabliser (stabiliser) position (down) for the stabilisers to work. Once stabilisers are down and set the switch must be placed in the boom (up) position for the booms to work.

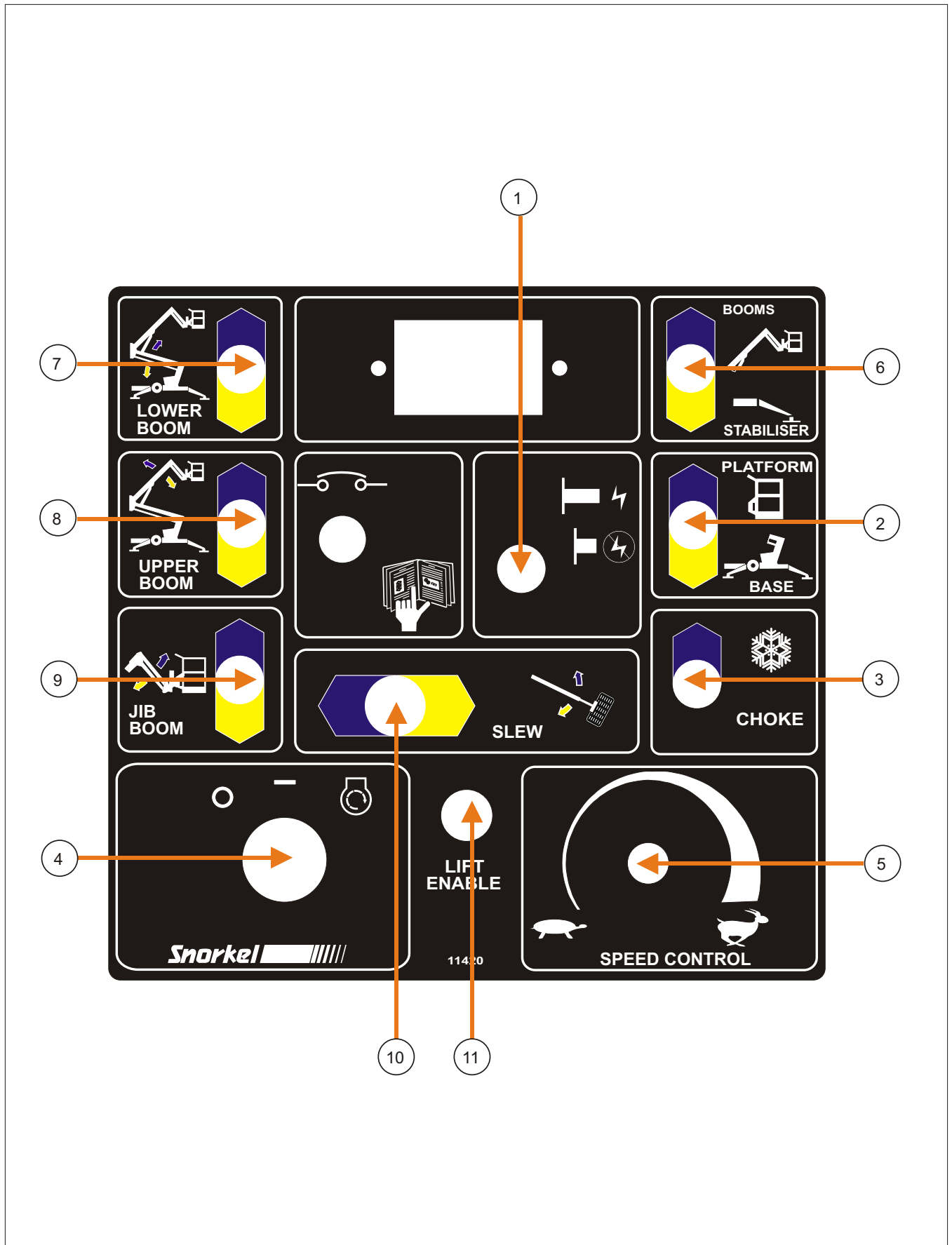
Control switches 7 through 10 are the platform moving switches. Each is a three position, momentary contact, normally OFF switch.

NOTE

(See "Nomenclature and Serial Numbers" in the "Specifications" chapter 3, for boom identification.)

7. **Lower Boom :** UP raises the lower boom. DOWN lowers the lower boom.
8. **Upper Boom:** UP raises the upper boom. DOWN lowers the upper boom.
9. **Jib Boom:** UP raises the jib boom. DOWN lowers the jib boom.
10. **Slew:** LEFT rotates the entire turntable and boom to the left. RIGHT rotates the entire turntable and boom to the right.
11. **Lift Enable:** The platform can only be raised when this light is lit. When this light is not lit the platform will not raise because the stabilisers are not properly set.

□ Ground Control Box Controls



6. Controls

■ Platform Control Box

Controls for operating the MHP15J from the platform are located on the platform control box, with the exception of the foot switch which is on the platform floor.

NOTE

The number of each control below corresponds to the control's call out on the control box illustration.

1. **Emergency Stop:** Press the EMERGENCY STOP switch cover down, at any time, under any conditions, and the entire machine stops, and nothing moves. This emergency stop switch cover must be up and the switch turned on for anything on the MHP15J to work.
2. **Choke/Cold Start:** Hold the switch UP while you start an engine that is at ambient air temperature (a "cold" engine). This will choke the engine.
3. **Anti-Restart:** This switch works like an automobile ignition switch. Hold it at START until the engine starts, then release it to ON (-). If the engine dies in ON, the key must be turned to OFF (O) before it will go back to START. Turn the switch to OFF if the platform is to stay in one position for a long time, that will turn the engine off and save fuel.
4. **Boom Speed:** This control determines how fast the booms move. Set it to SLOW (turtle) until you are very familiar with the way the machine works or if the platform is working in dangerous or cramped surroundings.
5. **Emergency Lower:** If the engine stops and cannot be restarted, hold the switch down and this will lower the upper and lower booms (not the jib boom). To slew during emergency lower operate emergency lower and slew switches together.
7. **Lower Boom:** UP raises the lower boom. DOWN lowers the lower boom.
8. **Upper Boom:** UP raises the upper boom. DOWN lowers the upper boom.
9. **Jib Boom:** UP raises the jib boom. DOWN lowers the jib boom.
10. **Slew:** LEFT rotates the entire turntable and boom to the left. RIGHT rotates the entire turntable and boom to the right.
11. **Lift Enable:** The platform can only be raised when this light is lit. When this light is not lit the platform will not raise because the stabilisers are not properly set.
12. **Foot Switch:** You must step down on the foot switch, and hold it down when you use any platform control that causes the platform to move.

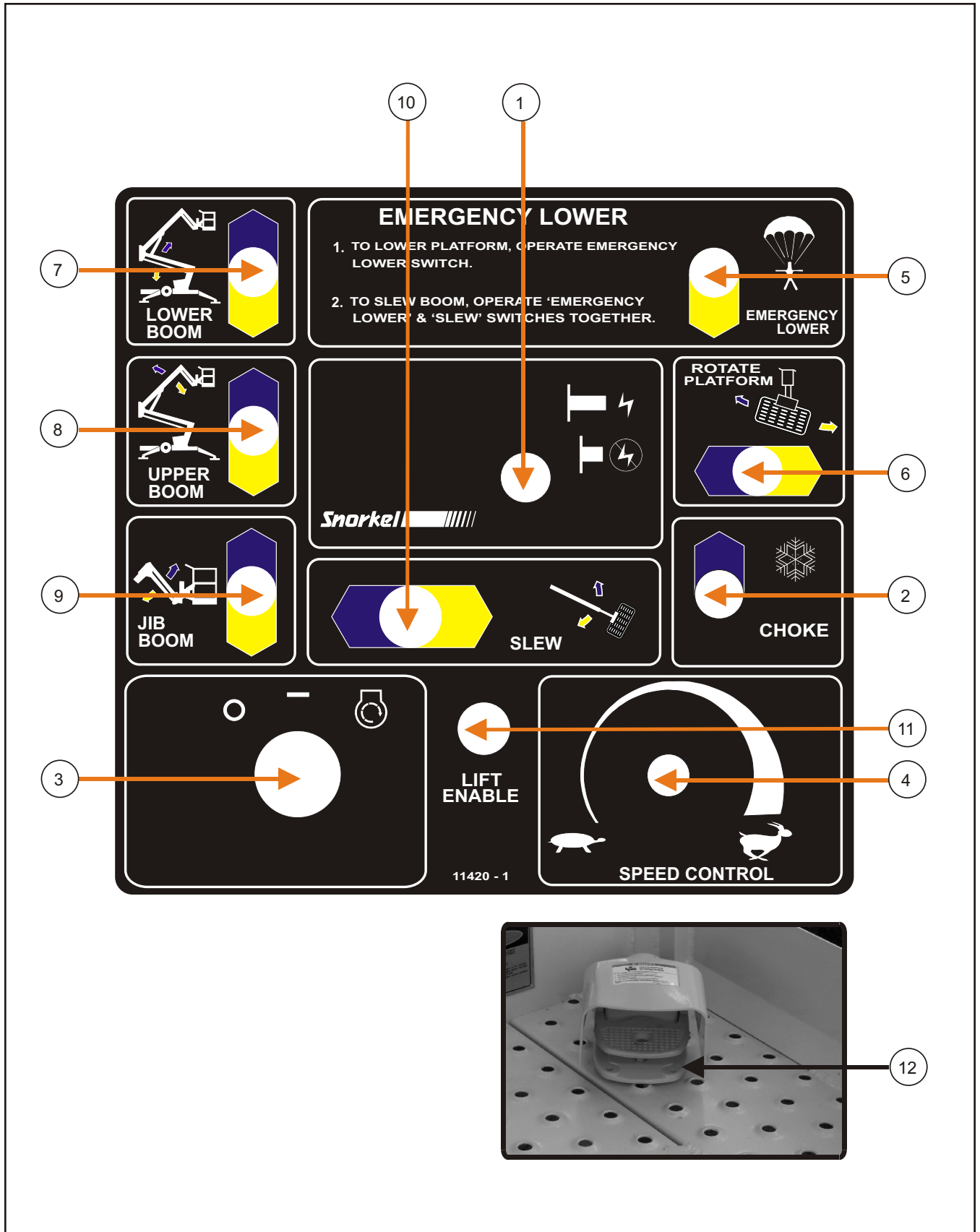
Items 6 through 10 are the platform moving switches. Each is a three position, momentary contact, normally OFF switch.

NOTE

(See "Nomenclature and Serial Numbers" in the "Specifications" chapter 3, for boom identification.)

6. **Platform Rotate:** (Option) LEFT rotates the platform left. RIGHT rotates the platform right.

□ Platform Control Box Controls



6. Controls

7. Pre-operational Inspection

At the start of each work day (or 8 hour shift), an MHP15J qualified operator must perform the Pre-operational Inspection as listed in the table below.

The purpose of the Pre-operational Inspection is to keep the MHP15J in proper working condition and to detect signs of malfunction at the earliest possible time.

The MHP15J should be in the STOWED POSITION and the **Master Key Switch** set to OFF before you begin this inspection.

Defective parts and/or equipment malfunctions jeopardize the safety of the operator and other personnel, and can cause damage to the machine.

⚠ DANGER

DO NOT operate an MHP15J that is known to be damaged or malfunctioning.

Repair all equipment damage or malfunctions, before placing the MHP15J into service.

■ Pre-operational Inspection Table

Item	Service Required
Engine fuel level	Look to see that the fuel tank is full
Fuel tank cap	Check to see that the cap is tight
Engine oil level	Check oil level (between dipstick lines)
Fuel leaks	Visually inspect (hoses and connections)
Engine coolant	Check that grills are not blocked
Wiring harnesses	Visually inspect (installation, condition)
Battery terminals	Visually inspect (no corrosion)
Battery fluid level	Check fluid level (1/4" or 6 mm below filler neck)
Hydraulic oil level	Visually inspect level (between lines on gauge)
Hydraulic oil leaks	Visually inspect (hoses, tubes)
Tires and wheels	Visually inspect (condition)
Bolts and fasteners	Visually inspect (condition)
Structural damage and welds	Visually inspect (weld cracks, dents)
Lanyard anchor points	Visually inspect (condition)
Platform gravity gate	Check condition and operation
Platform guardrails	Visually inspect (condition)
Flashing light (option)	Visually inspect (operation)
Ground control switches	Actuate and inspect for proper operation
Emergency lower	Check operation (causes correct motion)
Platform control box switches	Actuate and inspect for proper operation
RCD/ELCB AC outlet (option)	Check operation
Platform work lights (option)	Check operation
Placards and decals	Visually inspect (installation, condition)

7. Pre-operational Inspection

The rest of this chapter shows how to perform the inspection and maintenance required for each item in the Pre-operational Inspection Table.

■ Engine Cover

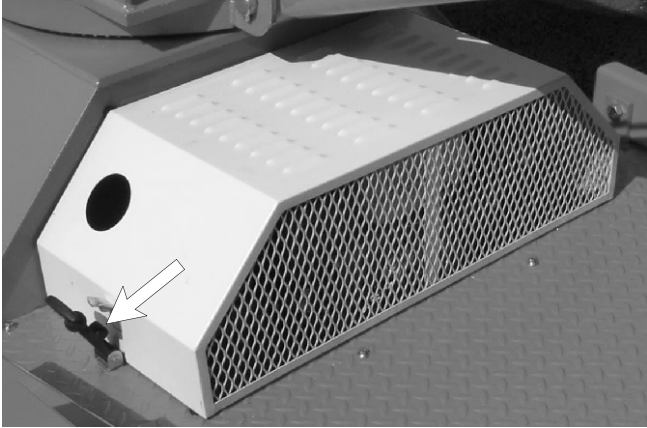


Figure 7.1 - Engine Cover

The engine is accessed by raising the engine cover. Check that the cover latches are secured properly.

■ Engine Fuel Level

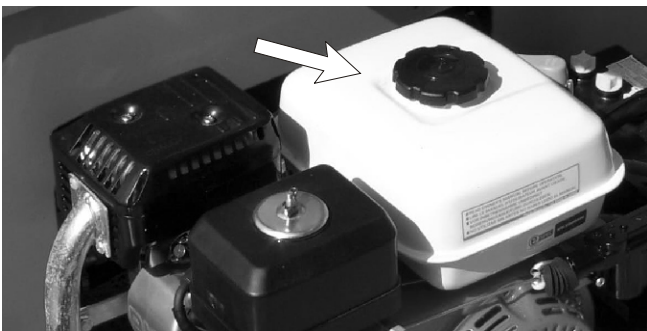


Figure 7.2 - Engine Fuel Level

Visually check to see that the gasoline tank is full. See the “Specifications” chapter 3, fuel for octane and grade.

■ Fuel Tank Cap

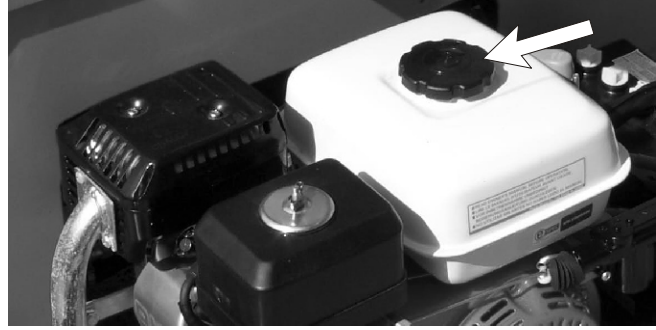


Figure 7.3 - Fuel Tank Cap

Check to see that the tank cap is in place and is tight.

■ Fuel Leaks

Visually inspect the Honda fuel tank and the entire length of the fuel line, from the engine to the fuel tank, for leaks.

■ Engine Oil Level

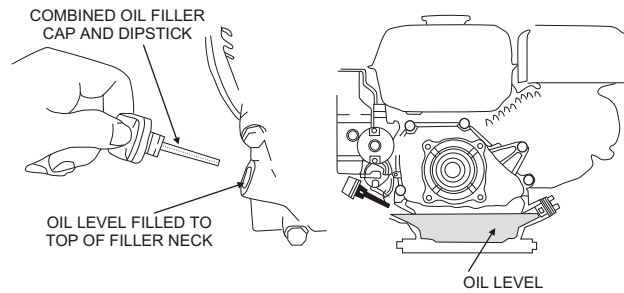


Figure 7.4 - Engine Oil Level

Remove the oil filler cap and wipe the dipstick clean. Insert the dipstick into the oil filler neck, but do not screw it in.

If the level is low, fill to the top of the oil filler neck with the recommended oil.

See the “Specifications” chapter 3, for the correct engine oil grade and weight.

■ Wiring Harnesses

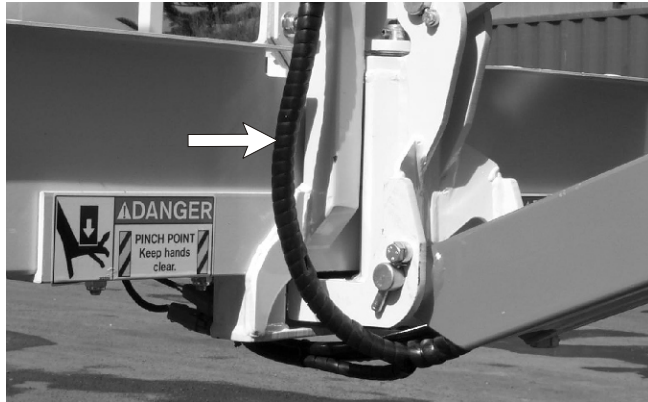


Figure 7.5 - Wiring Harnesses

Inspect all the wiring harnesses, on the machine, for loose connections, broken wires, and frayed insulation.

■ Battery Terminals

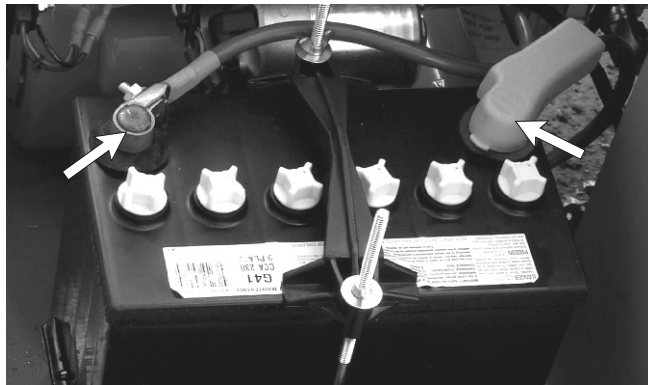


Figure 7.6 - Battery Terminals

Battery terminals should be tight, clean and free of dirt and corrosion.

■ Battery Fluid Level

▲ DANGER

Batteries emit hydrogen and oxygen, elements that can combine explosively.

DO NOT smoke or permit open flames or sparks when checking batteries.



Figure 7.7 - Battery Fluid Level

Remove the caps from the battery and visually check to see that the battery fluid is 1/4" (6 mm) below the bottom of the filler neck inside each hole.

■ Hydraulic Oil Level

To check the hydraulic oil level:

Completely lower the booms and ensure the stabilisers are in the stowed position.

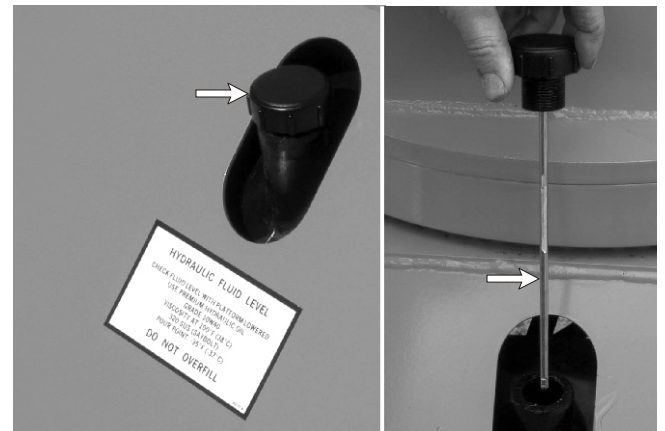


Figure 7.8 - Hydraulic Oil Level

The hydraulic oil level should be between the two marks on the dipstick.

If necessary, add hydraulic oil at the filler cap. See the "Specifications" chapter 3, for type and grade of hydraulic oil.

■ Hydraulic Oil Leaks

▲ DANGER

Leaking hydraulic oil can cause burns, fires, falls (slipping), cuts, and puncture wounds (if under high pressure). Do not search for leaks with your hand. Have a qualified trained maintenance person repair all hydraulic fluid leaks before you operate an MHP15J.

7. Pre-operational Inspection

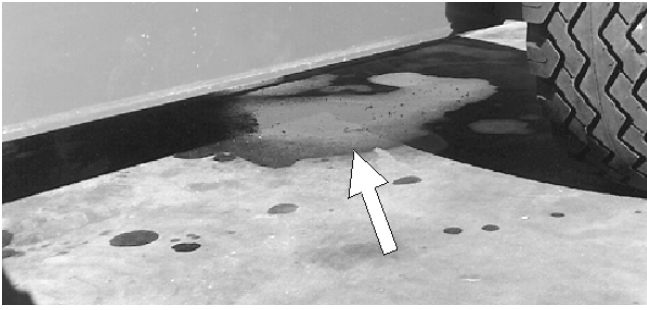


Figure 7.9 - Hydraulic Oil Leaks

Hydraulic oil leaks are easily visible and can show up anywhere.

Visually inspect the entire machine for hydraulic oil. Check the ground under the machine for leaked oil.

Carefully inspect the ends of the upper and lower booms. Oil can run down inside of the booms and drip out the end.

■ Bolts and Fasteners

Visually inspect all fasteners to see that none is missing or obviously loose.

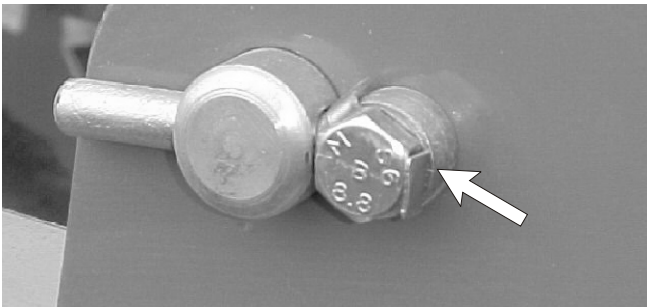


Figure 7.10 - Critical Pin Retainer Bolts

Critical pin retainer bolts have lock tab washers fitted, they should all be present and not damaged in any way.



Figure 7.11 - Wheel Nuts

Pay particular attention to all of the wheel nuts and bolts.

None should be visibly loose, missing, or deformed.

■ Wheels and Tyres

The MHP15J relies on its tyres for towing stability.



Figure 7.12 - Tyre Condition

Check each wheel for obvious damage that could cause a blowout.



Figure 7.13 - Tyre Pressure

Ensure tyre pressures are maintained according to the decal attached to the mudguard (fender).

■ Structural Damage and Welds

Visually inspect all welds for cracks, all structural members for deformity.

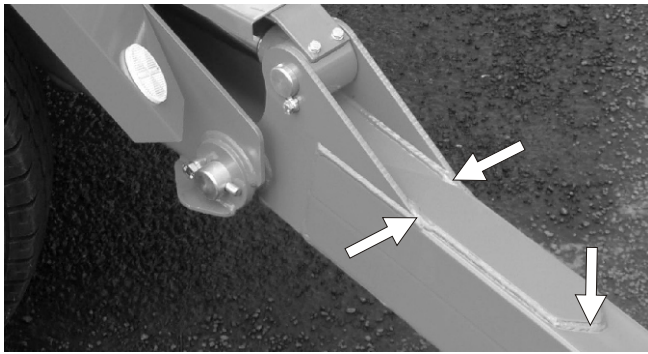
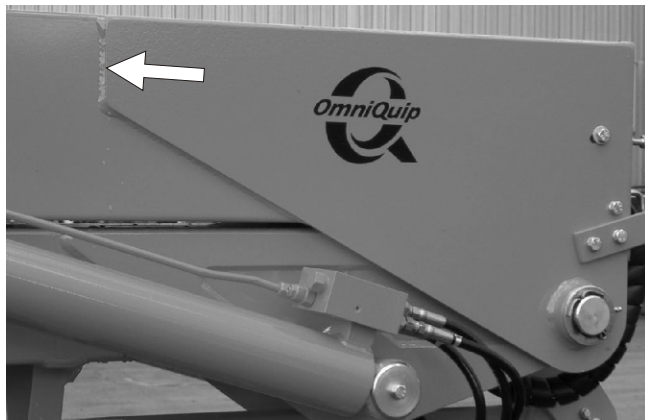


Figure 7.14 - Chassis Welds

Pay particular attention to the chassis welds



Figures 7.15 - Boom Welds

Closely inspect boom welds all the way around, for cracks.

■ Lanyard Anchor Points

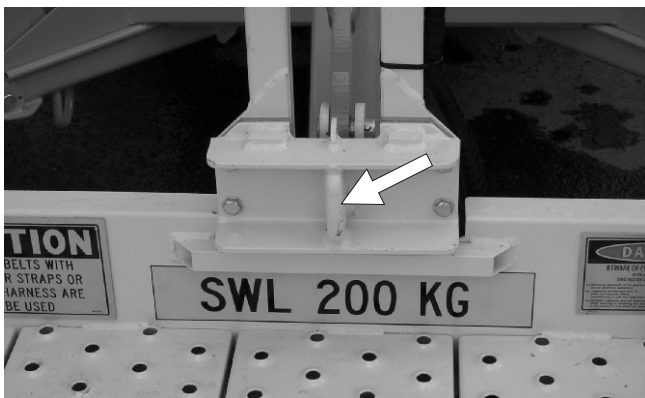


Figure 7.16 - Lanyard Anchor Points

Visually check the lanyard anchor points to see that they are not deformed or cut off.

■ Platform Gravity Gate

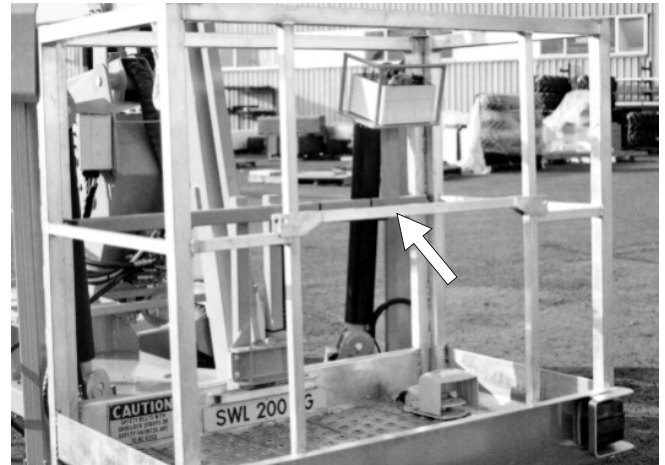


Figure 7.17 - Platform Gravity Gate

Check to see that the gravity gate is present and functions correctly.

■ Platform Guardrails



Figure 7.18 - Platform Guardrails

Visually inspect the platform guardrails to see that none of the tubing has been cut out, removed, or deformed in any way.

Visually check the guardrail welds to see that none is cracked nor ground down.

7. Pre-operational Inspection

■ Flashing Light (option)

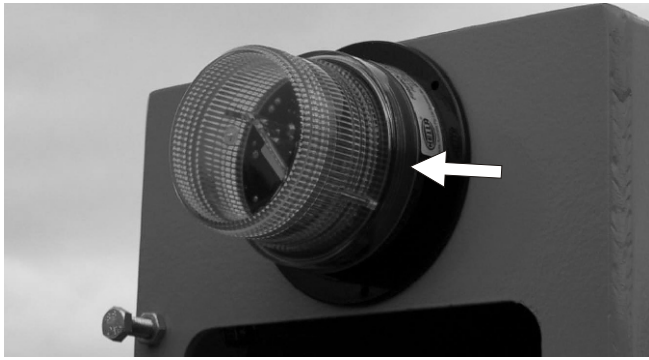


Figure 7.19 - Flashing Light

Visually check the optional flashing light, to see that the light flashes at approximately one flash per second when the motor key switch is turned on.

■ Ground Control Switches

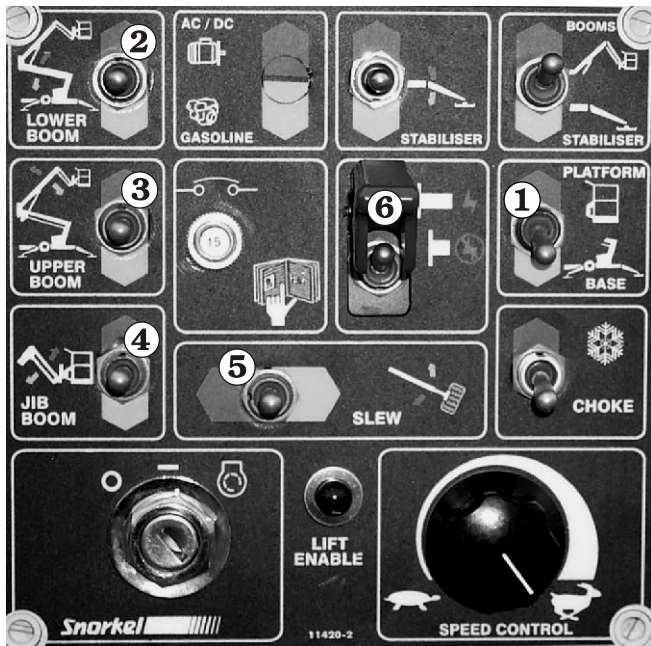


Figure 7.20 - Ground Control Switches

With the Ground/Platform Selector ① set to ground:

Check that each of the platform moving switches (② through to ⑤) cause the MHP15J to move the way it should.

Check both positions of each switch.

For correct operating procedures see the “Operation” chapter 8.

NOTE

Pay particular attention to the **Emergency Stop switch** ⑥ to see that it turns the MHP15J engine off when the red cover is struck.

■ Emergency Lower

□ Lower control box

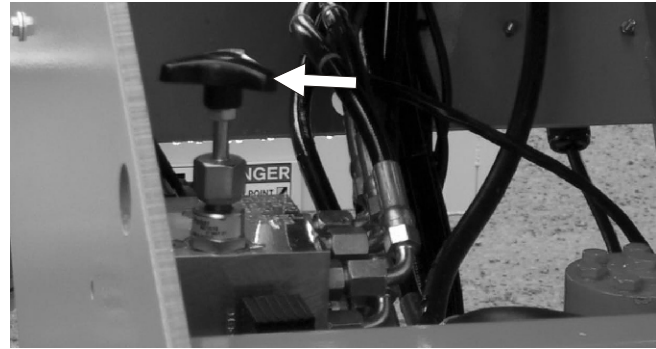


Figure 7.21 - Emergency Lower Valve

With the booms raised open the **Emergency Lower Valve** on the top of the manifold valve.

The booms should begin to lower. The rate of lowering can be regulated by the amount the valve is opened.

To check the slew function when using the manual emergency lower valve the **Master Key Switch** and **Emergency Stop** switch must be on and the **Platform/ground Selector** must be set to ground.

To slew (with the manual emergency lower valve already open) select the required direction on the slew toggle switch .

NOTE

The manual emergency lower valve must be closed after the test to ensure proper boom operation.

For correct emergency lowering operating procedures see “Emergency Operation” chapter 9.

□ Upper control box

Emergency lower from the upper control box is achieved by turning the upper control to on and depressing the foot switch whilst operating the **Emergency Lower** switch

To slew the unit select the direction required on the slew toggle switch at the same time. For correct emergency lowering operating procedures see “Emergency Operation” chapter 9.

■ Platform Control Switches



Figure 7.22 - Platform Control Switches

On the ground control box set the **Ground/Platform Selector** to platform.

Check that each of the platform moving switches (1 through to 5) cause the platform to move the way it should.

Check both positions of each switch.

For correct operating procedures see the "Operation" chapter 8.

NOTE

*Pay particular attention to the **Emergency Stop** switch 6 to see that it turns the MHP15J engine off when struck.*

Pay particular attention to the platform foot switch to see that it deactivates the platform moving switches when the foot switch is not stepped on.

■ AC Outlet RCD/ELCB (option)

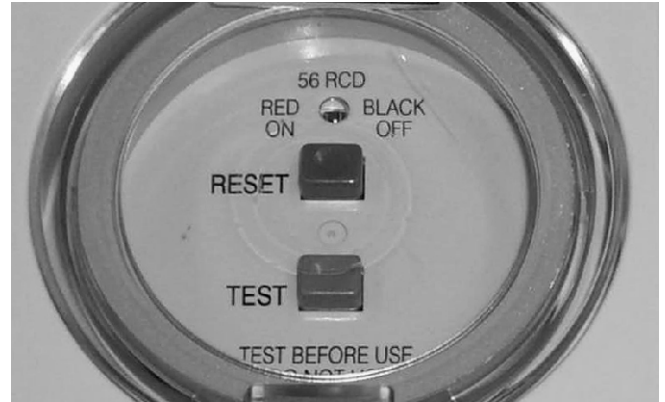


Figure 7.23 - AC Outlet RCD/ELCB

If the MHP15J has this option fitted check the RCD works by connecting a power source to the base inlet and an appliance to the platform outlet.

Push the test button on the RCD/ELCB device and the power outlet at the platform should not work.

CAUTION

RCD/ELCB devices should only be replaced by a qualified electrician.

7. Pre-operational Inspection

■ Placards and Decals

Look to see that all placards and decals are in place and legible. Replace any missing or illegible placards or decals before placing the MHP15J into service for the daily work shift.

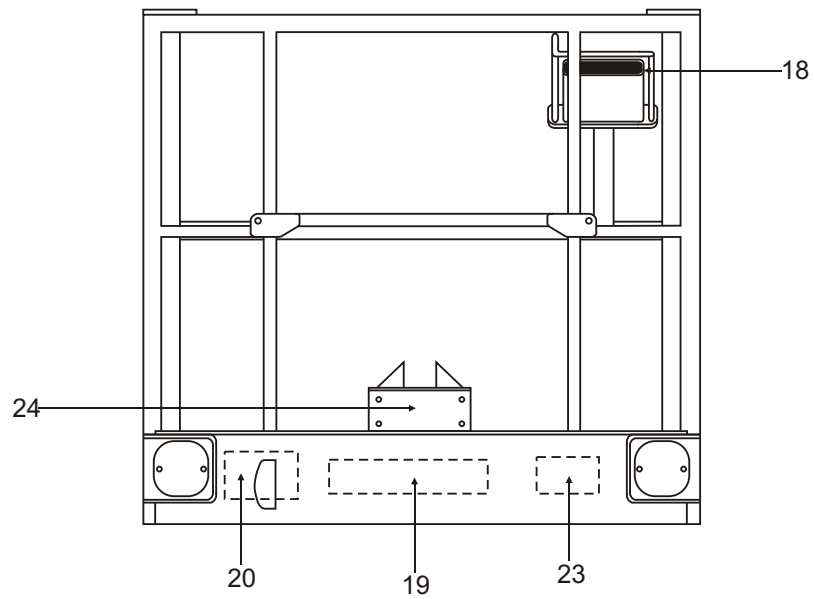
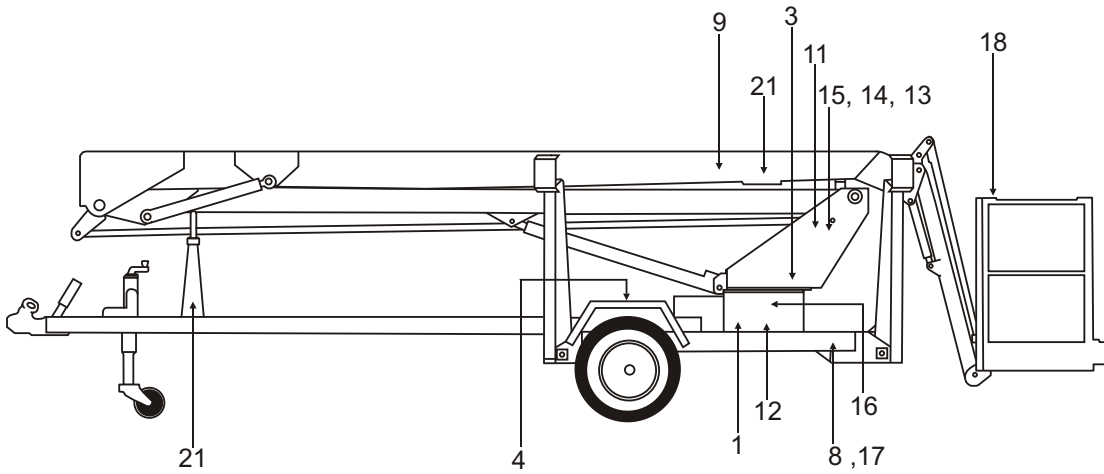
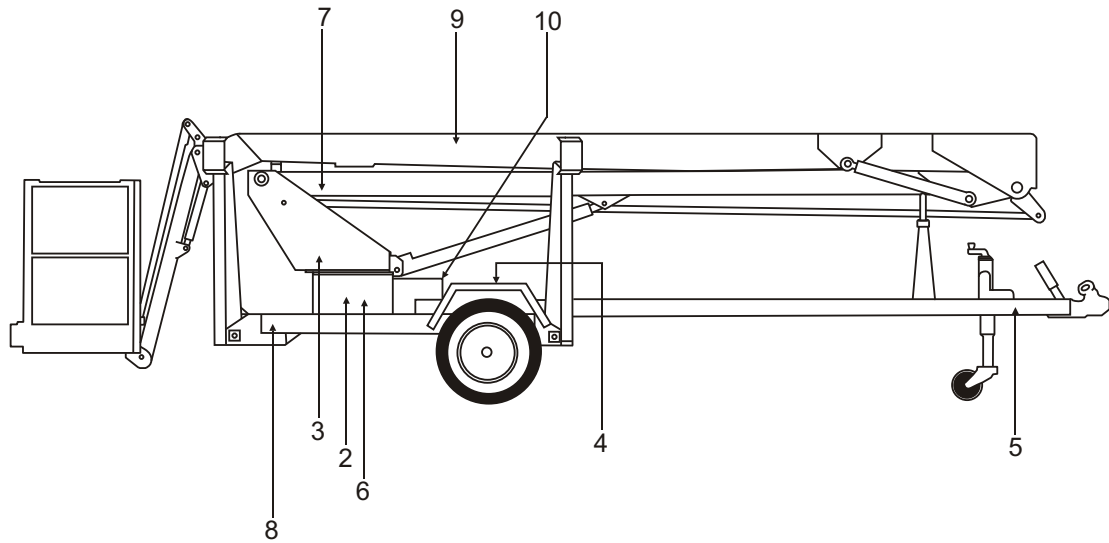
Decal and placard kits for the MHP15J are available from Snorkel dealers.

□ Standard placards and decals

See page 7 - 9 for the following items.

No	Part No	Description	Req
1	9972	Serial number plate	1
2	451776	Decal - Hydraulic fluid level	1
3	0112471	Decal - Snorkel	2
4	7856-45	Decal - Tyre pressure	2
5	7855	Decal - Towing speed	1
6	9207	Decal - Hydraulic oil	1
7	0070420	Decal - Emergency lower	2
8	560239	Decal - Snorkel	2
9	11966	Decal - MHP15J	2
10	007-1925	Decal - Gasoline	1
11	300699	Decal - Operator checklist	1
12	0130025	Decal - Warning	1
13	0323897	Decal - Danger	1
14	11420	Decal - Lower control box	1
15	0323899	Decal - Electrocutation hazard	1
16	11985	Decal - Stabiliser control	1
17	8945	Decal - Vin plate	1
18	11420-1	Decal - Upper controls	1
19	2025-200	Decal - Safe working load	1
20	99228	Decal - Caution	1
21	1772-002K	Decal - Boom lock pin	2
22			
23	9428	Decal - Danger (Australia Only)	1
	1843	Decal - Warning (NZ Only)	1
24	0150448	Decal - Harness point	1

□ Inspection drawing



■ Operating Procedures

This chapter explains how to properly start and operate an MHP15J. Read and understand all the previous chapters in this manual before you begin to operate an MHP15J.

▲ CAUTION

If you use the MHP15J for painting be sure the optional sandblast protection kit is installed to protect the hydraulic cylinder rods from paint. Do not leave the MHP15J engine running if you are sandblasting. Sand drawn into the air intake can erode engine parts.

■ Control Stations

An MHP15J can be operated from the ground control box or from the platform control box. There are basically two differences between ground control and platform control operations, both are safety related:

1. The ground control box can override the platform control box at any time. If a person operating the machine from the platform becomes incapacitated, a person on the ground can always take over machine control.
2. The stabilisers can only be selected from the ground control box and only when the booms are in the stowed position.

▲ DANGER

The MHP15J is not Electrically Insulated.

Death or Serious Injury to operating personnel, can occur if the machine should come into contact with energized electrical wires during operation.

DO NOT attempt to operate the MHP15J ground controls if the platform, booms, or any other conducting part of an MHP15J is in contact with energized electrical wires or if there is an immediate danger of such contact.

NOTE

See the "Electrical Hazard" section, in this manual for a complete explanation of the hazards concerning electricity.

■ Emergency Stopping

To stop an MHP15J, press the **Emergency Stop** switch cover down on either of the two EMERGENCY STOP switches at the ground control box or at the platform control box.



Figure 8.1 - Ground Control Box Emergency Stop Switch Location.



Figure 8.2 - Platform Control Box Emergency Stop Switch Location.

NOTE

For a complete discussion of the **Emergency Stop** switches, see "Controls" chapter 6, in this manual.

■ Operation Considerations

To use this chapter, first decide whether you will be starting and operating the MHP15J from the ground control box or the platform control box.

8. Operation

Begin at the section entitled "Starting From Ground Control Box", if you intend to start and run the MHP15J from the ground station.

Begin at the section entitled "Starting From Platform Control Box", if you intend to start and run the MHP15J from the platform.

■ Starting From Ground Control Box

Before you begin to operate the MHP15J from the ground control box, a qualified operator must perform the "Pre-operational Inspection" as described in chapter 7, of this manual.

To start the engine from the ground control box do the following:

1. Set the **Emergency Stop** switch **1** to ON (see Figure 8.3).

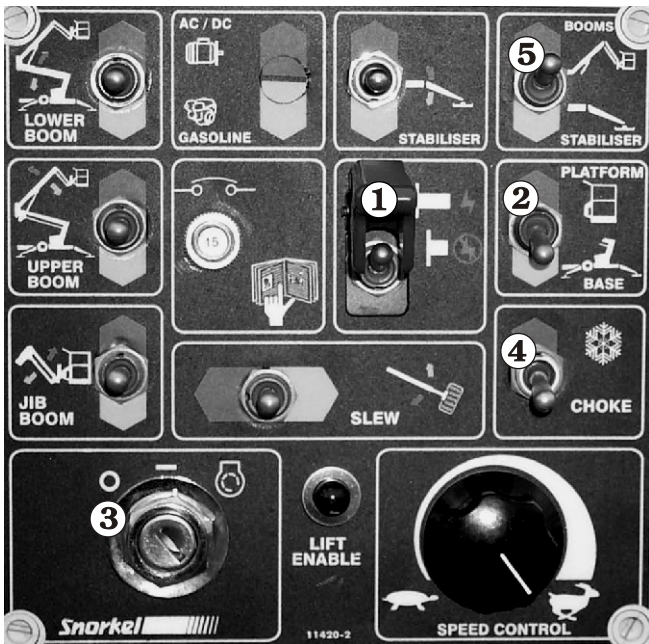


Figure 8.3

Figure 8.3 - Ground Control Box Starting

2. Set the **Platform/Ground Selector** switch **2** to GROUND (see Figure 8.3).
3. Insert the key **3** (see Figure 8.3) into the **Master Key Switch** and turn the key on.
4. If the engine is at ambient temperature (cold), hold the **Choke / Cold Start Switch** **4** (see Figure 8.3) up throughout the next step.
5. Turn the key to **Start** and hold it there until the engine starts or for a maximum time of 6 seconds. When the engine starts release the key **3** and the choke switch **4**, if you used it (see Figure 8.3).

⚠ CAUTION

If the engine does not start in 6 seconds turn the key off and release the choke. Wait 60 seconds before trying to restart the engine again. Continual cranking of the starter motor will only result in its damage.

The engine should now be running, and the MHP15J is ready to begin work.

■ Stabiliser Operation

□ Standard manual stabiliser operation

□ Setting the manually operated stabilisers

The booms must be in the stowed position.

Ensure the Boom/Stabiliser Switch (item **5** on the ground control box) (see Figure 8.3) is set to stabilizer.

Lower the stabilisers by pushing the individual valve levers down (see Figure 8.4)

NOTE:

Ensure that the front stabilisers are lowered first to prevent damage to the jockey wheel.

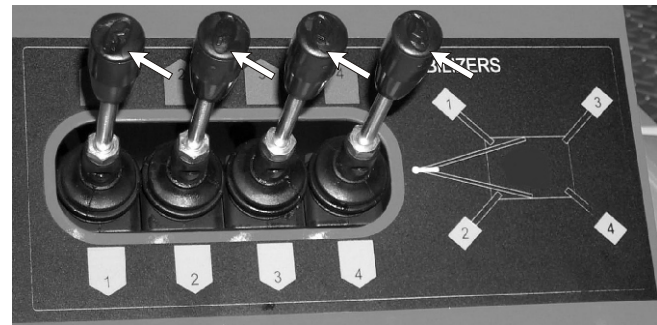


Figure 8.4

Lower the rear stabilisers and level the machine using the level bubble (see Figure 8.5) adjacent to the control levers.

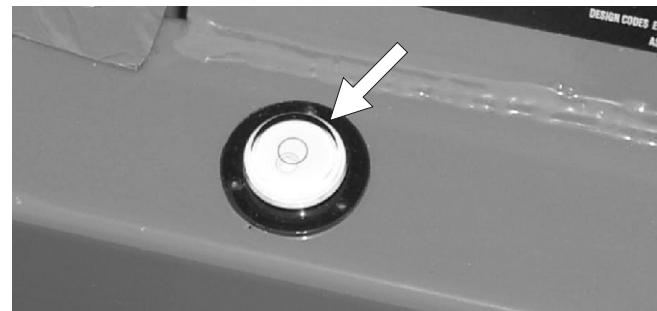


Figure 8.5

▲ CAUTION

Ensure all four foot plates are in full contact with the ground and that they are clear of manhole covers, drains and unstable ground etc.

☐ Raising the manually operated stabilisers

Raising the stabilisers is the reverse of setting the stabilisers.

The booms must be in the stowed position.

Ensure that the Boom/Stabiliser Switch is set to stabiliser.

Raise the stabilisers by pushing the individual valve levers up (see Figure 8.4).

NOTE:

Ensure that the rear stabilisers are raised first to prevent damage to the jockey wheel.

☐ Self levelling stabilisers (Optional)

This option allows the stabilisers to be lowered and the unit to be levelled by operating one switch at the lower control station.

☐ Setting the 'self levelling' stabilisers

To operate the 'self levelling' stabilisers the booms must be in the stowed position.



Figure 8.6

1. Set the Master Key Switch ① to ON (see Figure 8.6).

2. Select stabiliser using the Stabiliser/Boom switch ② (see Figure 8.6)
3. Momentarily (3 - 6 seconds) press the Stabiliser Lower Switch ③ (see Figure 8.6). This will lower all four stabilisers and allow the unit to "self level".

▲ CAUTION

Before raising the boom ensure all four foot plates are in full contact with the ground and that they are clear of manhole covers, drains and unstable ground etc.

The boom can now be operated in the normal manner.

☐ Raising the 'self levelling' stabilisers

To operate the stabilisers the booms must be in the stowed position.

1. Select stabiliser using the Stabiliser/Boom switch ② (see Figure 8.6).
2. Hold switch ③ in the raise mode (up) until all four stabilisers are fully raised in the stowed position.

NOTE:

For machines fitted with this option it is possible to set the stabilisers manually should this be desired.

☐ Setting the 'self levelling' stabilisers manually

To operate the 'self levelling' stabilisers manually the booms must be in the stowed position.

1. The Master Key Switch ① must be ON (see Figure 8.6)
2. Select stabiliser using the Stabiliser/Boom Switch ② (see Figure 8.6).
3. Hold switch ③ 'ON' (down) while each individual switch ④ is pushed down, one at a time, (see Figure 8.7) until all four stabiliser pads contact the ground ensuring that the front stabilisers are lowered first to prevent damage to the jockey wheel.

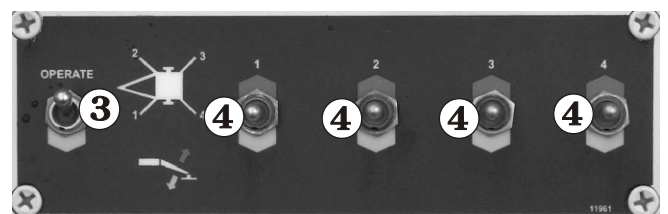


Figure 8.7

8. Operation

5. Activate the rear stabilisers and level the machine using the level bubble (see Figure 8.5).

⚠ CAUTION

Before raising the boom ensure all four foot plates are in full contact with the ground and that they are clear of manhole covers, drains and unstable ground etc.

The boom can now be operated in the normal manner

❑ Raising the 'self level' stabilisers manually

The booms must be in the stowed position.

Hold switch ③ 'ON' (down) while each individual switch ④ (see Figure 8.7) is pushed upward, one at a time, until all four stabilisers are completely up in their stowed position.

■ Starting From Platform Control Box

Before you begin to operate the MHP15J from the platform control box, a qualified operator must perform the "Pre-operational Inspection" as described in chapter 7, of this manual.

To start the engine from the platform control box you must first set some switches on the ground control box, including setting the stabilisers and leveling the machine.

(See page 8-2 for information on setting the stabilisers)

1. Insert the key ① into the **Master Key Switch** at the ground control box and turn the key on (see Figure 8.8).



Figure 8.8

2. Set the **Platform/Ground Selector** ② (see Figure 8.8) at the ground control box to PLATFORM.

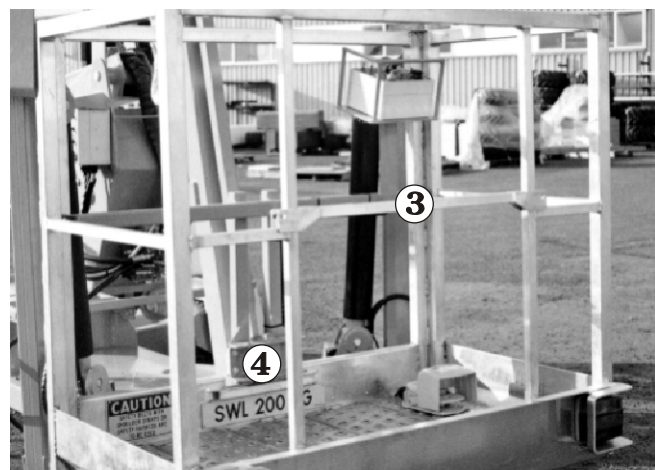


Figure 8.9

- Enter the platform, close the gravity gate ③, and attach the lanyard of your fall restraint (safety harness) to one of the anchor points ④ (see Figure 8.9).



Figure 8.10

- Set the **Emergency Stop** switch ⑤ to (ON) (see Figure 8.10).
- Turn the **Anti-Restart** switch ⑥ to ON (see Figure 8.10).
- If the engine is at ambient temperature (cold), hold the **Choke Switch** ⑦ (see Figure 8.10) up throughout the next step.
- Turn the **Anti-Restart** switch ⑥ to START and hold it there until the engine starts or for a maximum time of 6 seconds. When the engine starts, release the key (6) and the choke switch ⑦, if you used it (see Figure 8.10).

⚠ CAUTION

If the engine does not start in 6 seconds, turn the Anti-Restart switch OFF and release the choke. Wait 60 seconds before trying to restart the engine again. Continual cranking of the starter motor will only result in its damage.

The engine should now be running, and the MHP15J is ready to begin work.

■ Moving The Platform

The engine should already be running (as described earlier in this chapter), before you start this section.

⚠ DANGER

DO NOT operate near energized electrical conductors. Maintain the (M.S.A.D.), Minimum Safe Approach Distance to energized power lines. See the "Electrical Hazard" section, in this manual for a complete explanation of the hazards concerning electricity. Maintain the clearances shown on the decal attached to the platform.

Be certain that the space into which you are about to move the platform, boom, turntable, and/or chassis is free of obstructions. **ALWAYS** look in the direction of movement.

When you operate from the platform control box, be sure that the lanyard of your fall restraint is attached to an anchor point on the platform mount. Also, be sure that platform gate is closed behind you.

□ From Ground Control Box

Each of the ways the platform can move is shown in the following photograph and switch illustration:

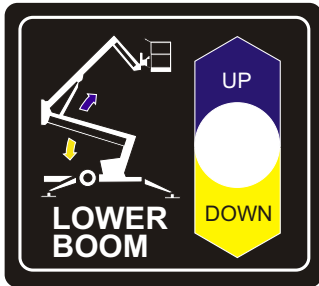
The photograph shows the platform switches that cause the platform or booms to move.

These platform moving switches, (① through ④), will produce the movement as indicated by the illustration's in Figure 8.12.

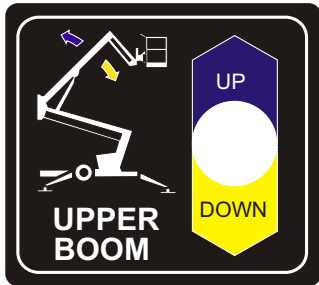


Figure 8.11 - Movement Control, Ground Control Box

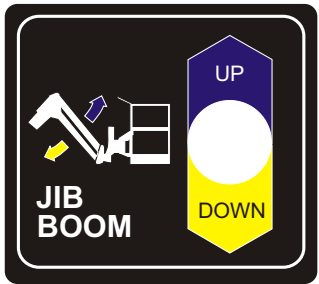
8. Operation



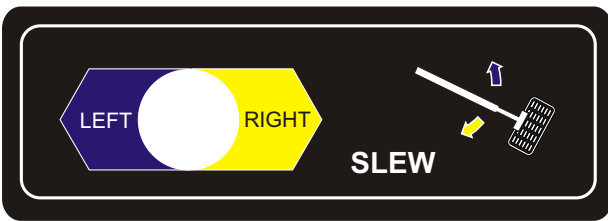
1. Lower Boom



2. Upper Boom



3. Jib Boom



4. Slew

Figure 8.12 - Ground Control Box Operation Platform Moving Switch Illustration

From Platform Control Box

When you operate from the platform control box, be sure that the lanyard of your fall restraint is attached to an anchor point on the platform mount. Also, be sure the gravity gate is closed. Each of the ways the platform can move is shown in the following photograph and switch illustration:

The photograph shows the platform switches that cause the platform or booms to move.

These platform moving switches, (1 through 5), will produce the movement as indicated by the illustration's in Figure 8.15.



Figure 8.13 - Movement Control, Platform Control Box

You must be stepping on the platform foot switch (6) when you use any of the platform moving switches (1 through 5). The platform foot switch is a safety feature to prevent the platform from moving if a platform moving switch, or controller, is accidentally pushed.

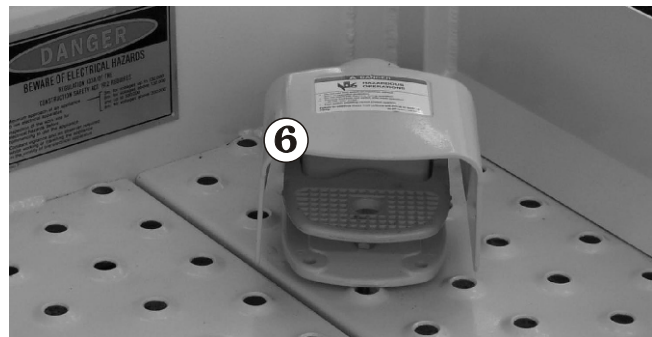
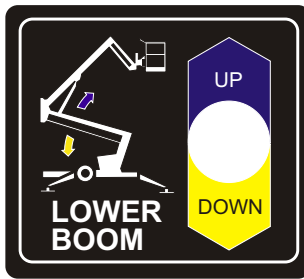
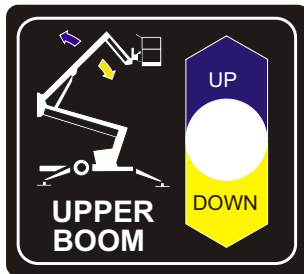


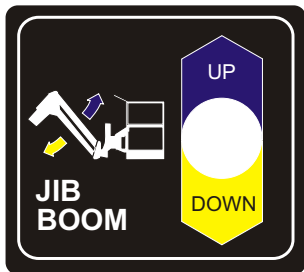
Figure 8.14 - Platform Foot Switch



1. Lower Boom



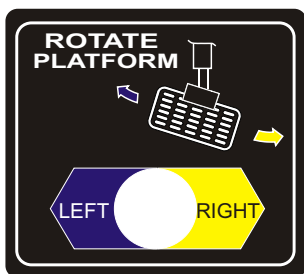
2. Upper Boom



3. Jib Boom



4. Slew



5. Platform Rotation

**Figure 8.15 - Platform Control Box Operation
Platform Moving Switch Illustration**

■ Securing for Day

At the end of each work day the MHP15J should be returned to the STOWED POSITION and locked as described under “Stowing” in the "Stowing and Transporting" chapter 10.

8. Operation

■ Emergency Operation Procedures

The following procedures are emergency procedures only. **DO NOT** use them for normal operation. Their purpose is to get the platform and operator safely to ground when the MHP15J will not start or some other problem keeps the platform from lowering in the normal way.

□ Operation From Platform Control Box

Switch settings listed in the three steps below must exist at the ground before emergency operation procedures will work at the platform control box:



Figure 9.1

1. The **Master Key Switch** ① must be ON (see Figure 9.1).
2. The **Emergency Stop** switch ② must be (ON) (see Figure 9.1).
3. The **Platform/Ground Selector** switch ③ (see Figure 9.1) must be set to PLATFORM.

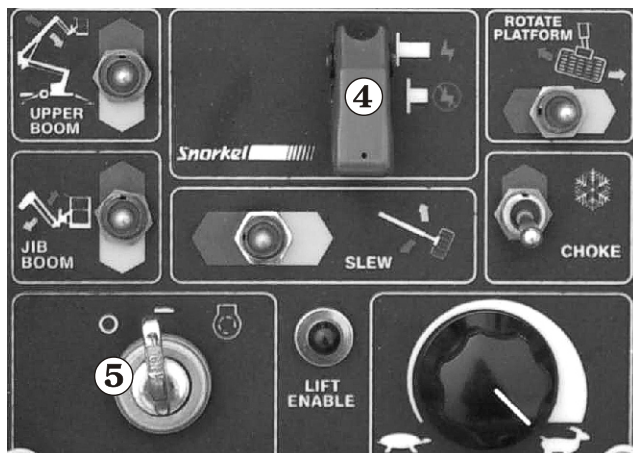


Figure 9.2

4. Set the **Emergency Stop** switch ④ to ON (see Figure 9.2).

5. Set the **Anti-Restart** switch ⑤ (see Figure 9.2) to ON.



Figure 9.3

6. Step on the platform foot switch ⑥ (see Figure 9.3).



Figure 9.4

7. Hold the **Emergency Lower** switch ⑦ (see Figure 9.4) down and the platform will begin lowering.

NOTE

To slew when using emergency lowering operate the slew switch ⑧ in the direction required (see Figure 9.4).

9. Emergency Operation

□ Operation From Ground Control Box

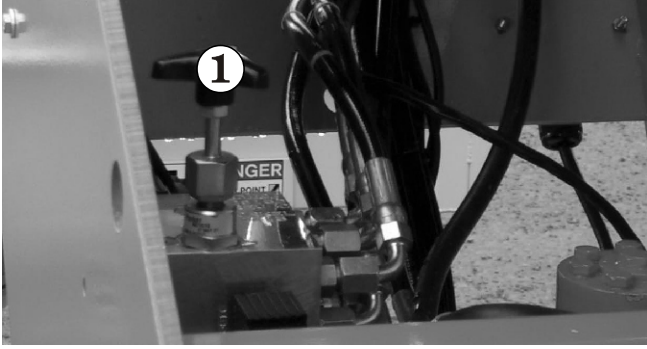


Figure 9.5 - Manual Lower Valve

1. Open manual valve ① to lower platform

NOTE

*To operate the slew function from the ground control box when using the emergency lowering valve the **Master Key Switch**, and **Emergency Stop** switch must be on and the **Platform/Ground Selector** must be set to ground. The slew direction can then be selected using the slew switch ⑧ (see Figure 9.1). The slew function will only operate while the booms are lowering.*

■ Stowing

At the end of each work day (or in preparation for lifting or storage) a qualified operator should put the MHP15J into its stowed position then lock by placing the two boom lock pins in position.

□ The correct stowed position is shown here.



Figure 10.1 - Stowed Position

To bring the MHP15J into the STOWED POSITION use the controls on the ground control box or platform control box to:

1. Fully lower all booms.
2. Align the lower boom travel lock with the boom rest mounted to the drawbar.
3. Place both boom restraints and keepers in place.

□ Upper boom latch

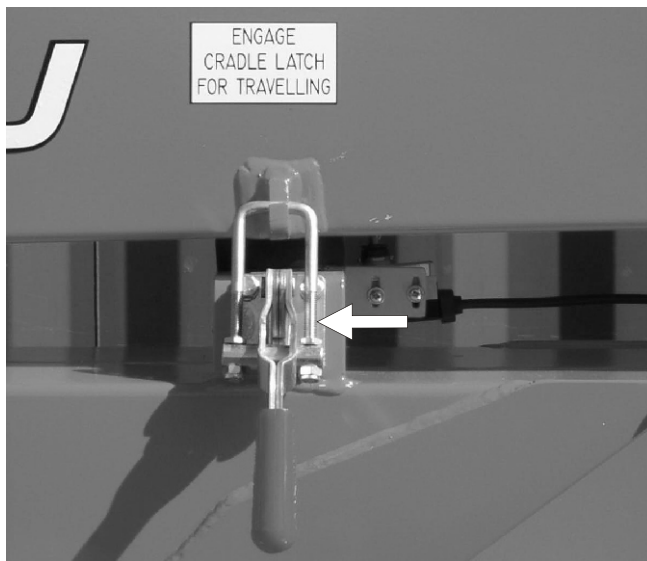


Figure 10.2 - Upper Boom Latch

□ Lower boom lock pin



Figure 10.3 - Lower Boom Lock Pin

If using the upper controls go now to the ground controls and:

4. Switch the **Ground / Platform** selector to ground.
5. Set the **Booms / Stabiliser** selector to stabiliser.
6. Using the stabiliser controls raise the stabilisers (rear first to avoid damage to the jockey wheel)
7. Set the **Master Key** switch on the ground control box to off and remove the key.

■ Transporting

□ Trailing

When moving the MHP15J on a transport trailer the following points must be adhered to.

▲ DANGER

1. The unit must be in the stowed position.
2. BOTH boom restraints **MUST** be in place.
3. Care must be taken when loading the unit onto the trailer that it does not run away. Chock the wheels and apply the handbrake.
4. The MHP15J can be loaded by forklift.

10. Stowing and Transporting

☐ Forklift points

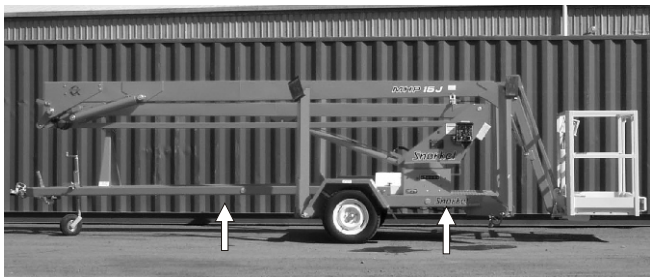


Figure 10.4 - Forklift Points

☐ Securing to a Transport Vehicle

5. Tie down only with the 4 tie down lugs.

DO NOT

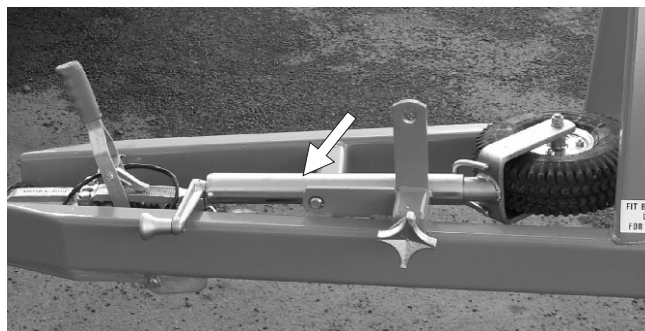
- Tie down over the draw bar.
- Tie down over the booms or level rods.
- Tie down over the platform.

Reverse the above procedure after transporting.

■ Towing

The correct size tow ball MUST be used when connecting the draw bar to the towing vehicle. The coupling is stamped with the correct size. Be aware of local transport regulations.

1. Visually inspect the tow ball on the towing vehicle.
2. Ensure the tow ball is matching in size with the tow coupling on the trailer.
3. Ensure the tow ball is mounted correctly and is fitted tightly.
4. Connect the tow coupling and ensure the latching mechanism is working and has latched.
5. Connect the break-away chain to the towing vehicle, unset the reversing lock on the tow coupling.
6. Check that the bolt, D-Clamp or attaching device is able to take the rated load.
7. Connect the trailer road lights to the towing vehicle and test that the functions work.
8. Retract the jockey wheel and place it in the stowed position (see photograph top right).



9. Check the covers are secure and no debris or work tools are in the platform.

⚠ DANGER

Death or Serious Injury can result from losing control of a trailer when towing. Never tow above the rated speed marked on the draw bar. Never tow the unit with an under rated vehicle. Always check manufacturers vehicle load specifications.

⚠ DANGER

BOTH Boom Restraints MUST be in place whilst the trailer is being towed.

■ Air Line To Platform

This consists of $\frac{1}{2}$ " pressure flex yellow hose rated at 150 psi working pressure, fitted with quick disconnect couplers at each end .

■ Dual Fuel

This option consists of an AC motor rated at either 110 or 230 volts AC 50/60Hz. A selector switch is used to change from gasoline to electric. The same controls are used to stop and start the electric motor.

This option is used in shopping malls and other built up areas.

■ Work Lights

Rubber encased work lights can be fitted to the platform guardrails. The lights are swivel mounted and each has its own switch.

■ Flashing Light

- For this option see Chapter 2 page 3

■ RCD/ELCB AC Outlet

A 3 core wire rated at 600 volts AC 15 amps is run up the booms as standard.

- For this option see Chapter 2 Page 3.

■ Sandblast Protection Kit

This option consists of a bellows type cover fitted to each boom cylinder shaft.

The bellows prevent sand and paint from damaging the cylinder rods and seals, and thus prevent hydraulic oil leaks.

▲CAUTION

DO NOT paint or sandblast from an MHP15J unless the cylinder rods are protected by bellows.

■ Platform Rotator

This option allows the operator to move the platform around the boom, 45° each side of center, to gain better access to work sites.

■ Self Levelling Stabiliser

This option consists of a microprocessor that controls the stabilisers. The stabilisers will 'self level' the platform when the auto mode is selected, alternatively the stabilisers can be used individually when in the manual mode.

11. Options

■ Hazardous Components

Snorkel products may contain materials and objects that potentially could become significant fire or environmental hazards during the lifetime of the machine.

1. Antifreeze (ethylene glycol)
2. Battery, lead/acid
3. Diesel fuel
4. Foam in tires
5. Gasoline
6. Hydraulic oil
7. Liquefied petroleum gas
8. Motor oil

The rest of this chapter lists manufacturers' information you will need if you ever have to control any of the above items during an upset or emergency.

☐ Antifreeze (UN 1993)

☞ Fire extinguishing media:

Dry Chemical, foam, or CO₂.

☞ Special fire fighting procedures:

Water spray may be ineffective on fire but can protect fire fighters and cool closed containers. Use fog nozzles if water is used.

▲ DANGER

DO NOT enter confined fire space without full bunker gear. (Helmet with face shield, bunker coats, gloves & rubber boots). Use a NIOSH approved positive pressure self contained breathing apparatus. Keep container tightly closed. Isolate from oxidizers, heat and open flame.

☞ Spill or leak:

Small - mop up with absorbent material and transfer to hood.

☞ Waste disposal method:

Small - evaporate until all vapors are gone. Dispose of remainder by legally applicable methods.

☐ Battery, Lead/Acid (UN 2794)

☞ Extinguishing media:

Dry chemical, foam, or CO₂.

☞ Special fire fighting procedures:

Use positive pressure, self contained breathing apparatus.

☞ Unusual fire and explosion hazards:

Hydrogen and oxygen gases are produced in the cells during normal battery operation.

▲ DANGER

Hydrogen gas is flammable and oxygen supports combustion. These gases enter the air through the vent caps. To avoid the chance of a fire or explosion, keep sparks and other sources of ignition away from the battery.

☞ Spill or leak:

Remove combustible materials and all sources of ignition. Contain spill by diking with soda ash (sodium carbonate) or quicklime (calcium oxide). Cover spill with either chemical. Mix well. Make certain mixture is neutral then collect residue and place in a drum or other suitable container. Dispose of as hazardous waste.

▲ DANGER

ALWAYS wear acid resistant boots, face shield, chemical splash goggles, and acid resistant gloves when handling acid spills or leaks.

NOTE

DO NOT release UN-neutralized acid!

☞ Waste disposal method:

Sulfuric Acid: Neutralize as above for a spill, collect residue, and place in a drum or suitable container. Dispose of as hazardous waste.

NOTE

DO NOT flush lead contaminated acid to sewer.

☞ Waste disposal method

Batteries: Send to lead smelter for reclamation following applicable federal, state, and local regulations.

☐ Diesel Fuel (NA 1993)

☞ Extinguishing media:

Use water spray, dry chemical, foam, or CO₂.

12. Fire Fighting and Chemical Control

☞ Special fire fighting procedures:

Use water to keep fire exposed containers cool. If leak or spill has not ignited, use water spray to disperse the vapors and to provide protection for personnel attempting to stop a leak. Water spray may be used to flush spills away from exposures.

☞ Unusual fire and explosion hazards:

Products of combustion may contain carbon monoxide, carbon dioxide, and other toxic materials.

▲ DANGER

DO NOT enter enclosed or confined space without proper protective equipment including respiratory protection.

☞ Spill or leak:

Contain spill immediately in smallest area possible. Recover as much of the product itself as possible by such methods as vacuuming, followed by soaking up of residual fluids by use of absorbent materials.

Remove contaminated items including contaminated soil and place in proper containers for disposal. Avoid washing, draining, or directing material to storm or sanitary sewers .

☞ Waste disposal method:

Recycle as much of the recoverable product as possible.

Dispose of non-recyclable material as a RCRA hazardous waste by such methods as incineration, complying with federal, state, and local regulations.

☐ Foam In Tires

☞ Extinguishing media:

Water, dry chemical, foam, or CO₂.

☞ Special fire fighting procedures:

Evacuate non emergency personnel to a safe area.

☞ Unusual fire and explosion hazards:

Fire fighters should use self contained breathing apparatus. Avoid breathing smoke, fumes, and decomposition products.

Use water spray to drench smoldering elastomer. Product may melt, after ignition, to form flammable liquid.

▲ DANGER

Burning produces intense heat, dense smoke, and toxic gases, such as carbon monoxide, oxides of nitrogen, and traces of hydrogen cyanide.

☞ Spill or leak:

Pick up and handle as any other inert solid material.

☞ Waste disposal method:

Not considered a hazardous material. Dispose of material according to any local, state, and federal regulations.

☐ Gasoline (UN 1203)

☞ Extinguishing media:

Dry chemical, foam, or CO₂.

☞ Special fire fighting procedures:

Water may be ineffective to extinguish, but water should be used to keep fire exposed containers cool. If a leak or spill has not ignited, use water spray to disperse the vapors and to protect personnel attempting to stop a leak. Water spray may be used to flush spills away from areas of potential ignition.

☞ Unusual fire and explosion hazards:

Highly Flammable. Products of combustion may contain carbon monoxide, carbon dioxide and other toxic materials.

▲ DANGER

DO NOT enter enclosed or confined space without proper protective equipment including respiratory protection.

☞ Spill or leak:

Review fire and explosion hazards before proceeding with clean up. Use appropriate personal protective equipment during clean up. Dike spill. Prevent liquid from entering sewers, waterways, or low areas. Soak up with sawdust, sand, oil dry or other absorbent material. Shovel or sweep up.

Remove source of heat, sparks, flame, impact, friction or electricity including internal combustion engines and power tools. If equipment is used for spill cleanup, it must be explosion proof and suitable for flammable liquid and vapor.

NOTE

Vapors released from the spill may create an explosive atmosphere.

☞ Waste disposal method:

Treatment, storage, transportation and disposal must be in accordance with applicable federal, state, provincial, and local regulations.

▲CAUTION

DO NOT flush to surface water or sanitary sewer system. By itself, the liquid is expected to be a RCRA ignitable hazardous waste.

☐ Hydraulic Oil (UN 1270)

☞ Extinguishing media:

Use water spray, dry chemical, foam, or CO₂.

☞ Special fire fighting procedures:

Water or foam may cause frothing. Use water to keep fire exposed containers cool. Water spray may be used to flush spills away from exposures.

☞ Unusual fire and explosion hazards:

Products of combustion may contain carbon monoxide, carbon dioxide, and other toxic materials.

▲DANGER

DO NOT enter enclosed or confined space without proper protective equipment including respiratory protection.

☞ Spill or leak:

Contain spill immediately in smallest area possible. Recover as much of the product itself as possible by such methods as vacuuming, followed by soaking up of residual fluids by use of absorbent materials.

Remove contaminated items including contaminated soil and place in proper containers for disposal. Avoid washing, draining or directing material to storm or sanitary sewers .

☞ Waste disposal method:

Recycle as much of the recoverable product as possible.

Dispose of non-recyclable material as a RCRA hazardous waste by such methods as incineration, complying with federal, state, and local regulations.

☐ Liquefied Petroleum Gas (UN 1075)

☞ Extinguishing media:

Water spray. Class A-B-C or BC fire extinguishers.

☞ Special fire fighting procedures:

Stop flow of gas. Use water to keep fire exposed containers cool. Use water spray to disperse unignited gas or vapor.

If ignition has occurred and no water available, tank metal may weaken from over heating. Evacuate area. If gas has not ignited, LP gas liquid or vapor may be dispersed by water spray or flooding.

☞ Unusual fire and explosion hazards:

Highly Flammable. Products of combustion may contain carbon monoxide, carbon dioxide and other toxic materials.

▲DANGER

DO NOT enter enclosed or confined space without proper protective equipment including respiratory protection.

☞ Spill or leak:

Keep public away. Shut off supply of gas. Eliminate sources of ignition. Ventilate the area. Disperse with water spray.

Contact between skin and these gases in liquid form can cause freezing of tissue causing injury similar to thermal burn.

NOTE

Vapors released from the spill may create an explosive atmosphere.

☞ Waste disposal method:

Treatment, storage, transportation and disposal must be in accordance with applicable federal, state, provincial, and local regulations.

☐ Motor Oil (UN 1270)

☞ Extinguishing media:

Use water spray, dry chemical, foam, or CO₂.

12. Fire Fighting and Chemical Control

Special fire fighting procedures:

Water or foam may cause frothing. Use water to keep fire exposed containers cool. Water spray may be used to flush spills away from exposures.

Unusual fire and explosion hazards:

Products of combustion may contain carbon monoxide, carbon dioxide, and other toxic materials.

▲ DANGER

DO NOT enter enclosed or confined space without proper protective equipment including respiratory protection.

Spill or leak:

Contain spill immediately in smallest area possible. Recover as much of the product itself as possible by such methods as vacuuming, followed by soaking up of residual fluids by use of absorbent materials.

Remove contaminated items including contaminated soil and place in proper containers for disposal. Avoid washing, draining or directing material to storm or sanitary sewers .

Waste disposal method:

Recycle as much of the recoverable product as possible.

Dispose of non-recyclable material as a RCRA hazardous waste by such methods as incineration, complying with federal, state, and local regulations.

■ Troubleshooting

All of the actions described in this chapter may be performed by an MHP15J operator, a trained and qualified service technician is not required.

The first column, of the following chart, lists some common problems encountered by MHP15J operators.

The second column lists some of the causes for each problem. The third column lists remedies.

□ Operator Troubleshooting Chart

⚠ CAUTION

Any problem that cannot be fixed by actions listed below should be referred to a trained and qualified MHP15J service technician.

Problem	Cause	Remedy
Engine will not crank.	1. Flat battery.	Replace / charge battery.
	2. Main circuit breaker, in ground control box, has tripped..	Reset circuit breaker , then try to start the engine. If it will not start, refer the problem to a qualified service technician.
	3. Loose battery terminals .	Tighten battery leads at battery.
Engine cranks but will not start.	1. Out of fuel.	Fill the engine with the correct type / grade of fuel.
	2. Fuel tap off.	Locate fuel tap on engine and turn to ON.
Engine runs but no outrigger function.	1. Leg / boom switch in lower control box incorrectly set	Switch to Stabilisers to operate stabilisers.
Engine runs but no boom function.	1. Speed control set too SLOW.	Turn Speed Control C.W. until function starts.
	2. Stabilisers not set correctly.	All stabilisers must be set on firm ground before boom functions will operate.
	3. Lack of hydraulic oil.	A. Check hydraulic system for leaks. B. Top up the oil tank with the correct type / grade of hydraulic oil.
Bleed down at platform inoperative.	1. Flat battery.	A. Charge / replace the battery. B. Use Manual Bleed Down from lower station.

13. Operator's Troubleshooting

A

AC outlet RCD/ELCB, 7-7

Additional information

see Introduction - page iv

Automatic Shut-offs

Circuit Breakers

Main Circuit Breaker, 5-1

Stabilisers, 5-1

B

Battery fluid level, 7-3

Battery terminals, 7-3

Bolts and fasteners, 7-4

Booms Identification, 3-4

C

Controls

Control switches

Anti-Restart, 6-4, 8-5, 9-1

Boom Speed, 6-2, 6-4

Choke/Cold Start, 6-2, 6-4, 8-2, 8-5

Emergency Lower, 6-4

Emergency Stop, 6-2, 6-4, 8-1

Emergency Stop switch, 8-2, 8-5, 9-1

Foot Switch, 6-4

Jib Boom, 6-2, 6-4

Lift Enable, 6-2

Lower Boom, 6-2, 6-4

Master Key Switch, 6-2, 7-1, 8-2, 8-4, 9-1

Platform Rotate, 6-4

Platform/Ground Selector, 6-2, 8-2, 8-4, 9-1

Slew, 6-2, 6-4

Stablizer / Boom Secector Switch, 6-2

Upper Boom, 6-2, 6-4

Ground Control Box, 6-2

Control switches, 6-2

Controls location illustration, 6-3

Platform Control Box

Control switches, 6-4

Controls location illustration, 6-5

Controls and Control Decals Locations, 6-1

Crushing hazard, 1-2

E

Electrical

Electrocution, 1-1, 8-1

Electrical Hazard Warning

see Electrical Hazard - page i

Emergency lower, 7-6

Emergency Operation, 9-1

Operation From Ground Control Box, 9-2

Operation From Platform Control Box, 9-1

Procedures, 9-1

Engine

Cooling system, 3-2

Displacement, 3-2

Engine oil level, 7-2

Fuel, 3-2

Fuel consumption, 3-2

Fuel grade, 3-2

Fuel leaks, 7-2

Fuel tank cap, 7-2

Ignition system, 3-2

Make, 3-2

Model, 3-2

Oil capacity, 3-2

Oil grade, 3-2

Type, 3-2

F

Falling hazards, 1-1

Flashing light, 7-6

G

Gauges

Hourmeter, 4-1

Hydraulic Oil Level, 4-1

Level Bubble, 4-1

General Specifications, 3-1

Ground Control Box Controls, 6-3

H

Hazardous Components, 12-1

Battery, Lead/Acid (UN 2794), 12-1

Gasoline (UN 1203), 12-2

Hydraulic Oil (UN 1270), 12-3

Motor Oil (UN 1270) , 12-3

Hydraulic oil

Filler cap, 7-3

Hydraulic oil level, 7-3

I

Inspection

Operators daily inspection, 7-1

Inspection and Maintenance Table, 7-1

Insulation rating, 3-1

L

Left side view of machine, 3-5

Index

Light Flashing, 7-6
Lower control box, 7-6

M

Maintenance personnel
 see Introduction - page iii
Maximum height to basket floor, 3-1
Maximum outreach, 3-1
Maximum outreach height, 3-1
Maximum rated axle capacity, 3-1
Maximum towing speed, 3-1
Minimum Safe Approach Distance
 see Electrical Hazard - page ii

N

Nomenclature And Serial Numbers, 3-4

O

Operating Procedures, 8-1
 Control Stations, 8-1
 Emergency Stopping, 8-1
 Moving The Platform, 8-5
 Starting From Ground Control Box, 8-2
 Starting From Platform Control Box, 8-4
Operation, 8-1
Operators
 Qualified, 7-1, 8-2
Other Safety Devices, 2-1
Overall height, 3-1

P

Placards and decals, 7-8
 Inspection drawing, 7-9
 Standard placards and decals, 7-8
Platform
 Foot switch, 8-6
 Lanyard anchor points, 7-5
Platform Control Box Controls, 6-5
Platform size, 3-1
Pre-operational Inspection Table, 7-1
Pre-start Inspection, 1-1

Q

Qualified operators
 see Introduction - page iii

R

RCD/ELCB Outlet (option), 5-1
Responsibilities of owners and users
 see Introduction - page iv
Right side view of machine, 3-4

S

Safe Operation, 1-1
Safe working load, 3-1
Safety Decals and Placards, 1-3
 Location illustration, 1-4
Safety Devices
 Bubble level, 2-2
 Emergency Stop Switches, 2-1
 Flashing light, 2-3
 Foot switch, 2-2
 Gravity gate, 2-2
 Guardrails, 2-2
 Lanyard anchor points, 2-1
 RCD/ELCB AC outlet, 2-3
 Safety Device Information, 2-1
Safety precautions
 Fuel Handling Precautions, 1-3
 Mounting and Dismounting Precautions, 1-2
 Operating Precautions, 1-2
 Operator, 1-2
 Operator Maintenance Precautions, 1-3
 Personnel Precautions, 1-2
 Starting and Stopping Precautions, 1-2
Sandblast protection kit, 8-1
Securing for Day, 8-7
Signs, Caution, Danger, Notes
 see Introduction - page iii
Standard colour, 3-1
Stowing
 Trailing
 Forklift points, 10-2
Stowing the MHP15J, 10-1
 Boom lock pins, 10-1
 Boom restraints and keepers, 10-1
Structural damage and welds, 7-4
 Boom welds, 7-5

T

Tipover hazard, 1-1
Towing, 10-2
 Bolt, D-Clamp or attaching device, 10-2
 Jockey wheel, 10-2
 Latching mechanism, 10-2
 Road lights, 10-2
 Tow ball, 10-2
Trailer tongue weight, 3-1
Transporting
 Trailing
 Forklift points, 10-2

Transporting the MHP15J, 10-1
 Securing to a Transport Vehicle, 10-2
 Trailing, 10-1
Travelling height, 3-1
Troubleshooting, 13-1
 Operator Troubleshooting Chart, 13-1
Turntable rotation, 3-1

W

Warranty - Limited
 see inside front cover
Weight, 3-1
Wheels and tyres, 7-4
Wiring harnesses, 7-3
 Loose connections, 7-3
Work Place Inspection and Practices, 1-1
Working Envelope MHP15J, 3-3
Working height, 3-1

