

LX70/80

HITACHI

LX70 LX80

W H E E L L O A D E R

LX70/ LX80

Engine Rated Power

: 64.7 kW (88 PS) / 80.9 kW (110 PS)

Operating Weight

: 6 415 kg / 8 120 kg

Bucket Capacity

: 1.2 m³—1.6 m³ / 1.2 m³—1.9 m³



Higher Operating Efficiency

HST

Hydro-Static Transmission

Power and speed are well matched through the advanced HST.



Even More Safety

A simple press of a button sets or releases the electronically operated parking brake.

Gentle to the Environment

Clean-operating and powerful engine complies with Emission Regulation U.S. EPA Tier 2.

Nimble control from HST

High and low speeds cover entire speed range. Inching pedal offers smooth speed control. QSS is standard equipment.

Operability and Productivity

This model matches front power and traction for productivity. The Hitachi HST system also helps reduce fuel consumption. The light and easy action of the control levers helps operability.

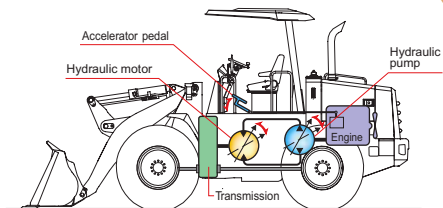

■ HST System

Note: Illustration shows LX70-1 model.





Clear view from cab front

A pillar-less design gives an unobstructed view of the front. Sun visor is standard on cab-equipped models only.



Finger-tip operated shift lever

Shift lever provides finger-tip control of forward/reverse and high/low speed selection.



Easy-to-monitor instrument panel



ROPS/FOPS* cab (Option)

This rigid cab is ready "just in case" to help protect the operator from falling objects or during a rollover. The rear-hinged door makes entry and exit easy.

*ROPS: Rollover Protective Structure. Conforms to ISO3471, 1994

*FOPS: Falling-Object Protective Structure. Conforms to ISO3449, 1992 Level II



Engine room bulkhead

A bulkhead is installed between the engine and the pump.



Front control lever lock

Locks the controls to prevent unintentional operation.



Electronically operated parking brake

Dual brake system

A dual brake system is used. It has wet disc brakes on the front and rear axles. A HST brake is also used.



Shift lever lock

Can be easily set to prevent accidental operation of the shift lever.



Fully enclosed engine fan guard

A guard completely encloses the engine fan.

Comfortable Operation & Safety

Equipped for a safe and comfortable operation.



Clear back view for safe maneuvering

New engine cover shape provides a clear view.

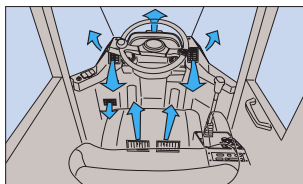

External air induction air conditioning (Option)

This powerful air conditioning can be switched between re-circulating air inside the cab or drawing it in from outside. (Cab-equipped models only)



Switches are easy to view and reach



Quick shift switch (QSS)

The speed range made changes from Hi to Low when the switch is pressed and changes from Low to Hi when the switch is pressed again.



Deluxe suspension seat

The comfortable cloth-covered seat offers both suspension and reclining adjustment. (Cab-equipped models only)

AM/FM radio with automatic station selection

The operator can easily select the desired station using the touch-type LCD panel. (Cab-equipped models only)

Axle with torque proportioning differential gear

Helps to reduce wheel spinning when operating on rough terrain.

Quick On Start (QOS) system

Automatic preheating engages when key is turned on. Once glow lamp is out, the engine can be quickly started, even in cold weather.



Notes: Canopy is equipped as standard.
Cab is available as option.

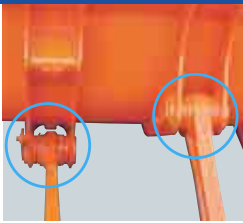

Double sealed bucket pins
Double seals (dust seal and O-ring) are provided at bucket hinge pin and linkage pins. They seal out dirt and keep grease inside.



Convenient lubrication
The bucket cylinder bottom pin and other points can be easily lubricated from the ground.



Easy-to-check fluid level gauge
This gauge allows the level of the hydraulic fluids to be checked from ground level with just a glance.

Easy Maintenance

For more care from less effort

Restricted access

Locks have been added to crucial areas to help ward off unauthorized access or vandalism. The fuel cap and side cover can be locked with the engine key. The following areas can be locked.

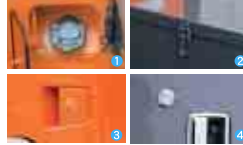

- 1 Fuel cap
- 2 Battery box
- 3 Side cover
- 4 Cab door (Cab-equipped models only)



Wide steps
These large steps make entry and exit easy.

Wide-opening battery cover
Swings out of the way for fast battery maintenance or replacement.

Large side cover
The large side cover opens to provide easy access.

Swing-open rear grill
Facilitates easy radiator cleaning.

Notes: This photo shows the model with the inspection covers open. Always close these inspection covers before operation. Cab is optional.

Wide Range of Attachments

Buckets



Standard general purpose bucket with bolt on cutting edges
Best for stock piling loose dirt and rock.

General purpose bucket with bolt on teeth
A good choice for relatively dense material, such as dense dirt, gravel or dirt with clumps and rocks.

Note: Refer to Specification Catalog for details.

Tires

Tread patterns



L2: Traction tire



L3: Rock tire (option)

Rock tire designs and applications

- Nylon breaker
Perfect for hard surfaces and standard road applications.
- Steel breaker
This is the tire for use where the stones have sharp edges.
- Side steel breaker
The choice for harsh conditions where stones have sharp edges.

Attachments & Options



Lumber forks
Helps handle square beams, lumber or other such material. Fork width can be manually adjusted to the width of the load.

High-lift arm (Special option)
This extended arm gives higher dumping clearance.



Log grapple
This dedicated attachment allows the loader to handle logs and other round materials.



Quick coupler: Hydraulic type (For quick attachment changing)
Allows attachments to be mounted or removed by controls in the cab.



DIMENSIONS

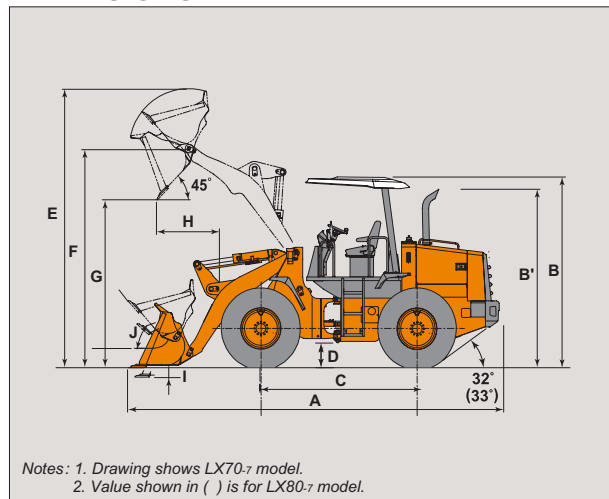

Unit : mm

	LX70-7	LX80-7
A Overall length	6 085	6 360
B Height to top of canopy and cab	3 045	3 140
B' Height to top of exhaust	2 885	2 985
Width over tires	2 180	2 320
C Wheelbase	2 600	2 600
D Ground clearance	350	365
Tread	1 725	1 820
Bucket width	2 340	2 480
Turning radius (centerline of outside tire)	4 440	4 690
Loader clearance circle, bucket in carry position	5 215	5 470
E Overall operating height	4 515	4 675
F Height to hinge pin, fully raised	3 500	3 605
G Dumping clearances 45 degree, full height	2 695	2 740
H Reach, 45 degrees dump, full height	1 015	1 030
Reach, 45 degrees dump, 7ft (2.13m) clearance	1 435	1 480
I Digging depth (horizontal digging angle)	100	85
J Max. roll back at carry position	48 deg.	48 deg.

Note: General purpose bucket with bolt on cutting edges.

SPECIFICATIONS

		LX70-7	LX80-7
Bucket capacity (ISO heaped) with bolt on cutting edges	m ³	1.3	1.6
Operating weight Canopy/Cab (ROPS/FOPS)	kg	6 415 / 6 905	8 120 / 8 610
Hydraulic cycle times	Lift arm Raise/Lower	s	5.0 / 3.0
	Bucket dump	s	1.0
Max. travel speed	Forward/Reverse	km/h	34.5 / 34.5
Transmission		HST (Hydrostatic Transmission) and 2-speed (high/low) powershift transmission	
Breakout force	kN (kgf)	61.7 (6 300)	79.4 (8 100)
Engine	Type	ISUZU BB-4BG1T	
	Rated power (DIN 6271,net)	kW/min ⁻¹ (PS/rpm)	64.7 / 2 100 (88 / 2 100)
	Rated power (SAE J1349,net)	kW/min ⁻¹ (HP/rpm)	64.7 / 2 100 (87 / 2 100)
	Piston displacement	L	4.3
Service brake		Wet disc type	
Parking brake		Wet disc type	
Tire size		15.5-25-8PR (L2)	17.5-25-12PR (L2)
Fuel tank capacity	L	130	155

Note: Specifications are based on machine with all standard equipment.

Standard Equipment

Cab

- Canopy (2-pillar)
- Adjustable vinyl covered seat with seat belt
- Combination shift lever
- Front control lever lock
- Shift lever lock
- Rear view mirror

Features

- HST (Hydro-static transmission)
- Front /Rear torque proportioning differentials
- Automatic bucket return-to-dig control
- Quick Shift Switch (QSS)
- Two-function hydraulic valve with single lever
- Power steering
- Parking brake
- Sealed wet disc type brake

Others

- 1.3 m³ general purpose bucket with bolt on cutting edges :LX70-7
- 1.6 m³ general purpose bucket with bolt on cutting edges :LX80-7
- Parking brake with electric switch
- Reverse warning alarm
- 15.5-25-8PR (L2) tires:LX70-7
- 17.5-25-12PR (L2) tires:LX80-7

Note: Standard equipment may vary depending on countries, so please consult your Hitachi dealer for details.

Optional Equipment

- ROPS/FOPS Canopy
- ROPS/FOPS cab
- Steel cab
- Air conditioning (for the cab)
- Quick coupler:Hyd. type
- Lumber forks
- Log grapple
- Ride control system
- Tropical package
- Logging package

LX70-7

- 1.2 m³ general purpose bucket with bolt on teeth
- 1.6 m³ light material handling bucket with bolt on cutting edges

LX80-7

- 1.5 m³ general purpose bucket with bolt on teeth
- 1.9 m³ light material handling bucket with bolt on cutting edges

Note: Optional equipment may vary depending on countries, so please consult your Hitachi dealer for details.

Hitachi Construction Machinery Co., Ltd.

Head Office: 5-1 Koraku 2-chome, Bunkyo-ku,
Tokyo 112-8563, Japan

Telephone: (03)3830-8050

Facsimile: (03)3830-8204

These specifications are subject to change without notice. Illustrations and photos show the standard models, and may or may not include optional equipment, accessories, and all standard equipment with some differences in color and features. Before use, go through Operator's Manual for proper operation.

KL-E113

03.10 (CD/KA, GT₃)

Printed in Japan