

Atlas Copco Instruction Manual



Instruction Manual
for Portable Compressors
English

XAMS 407 Cd - XAMS 850 CD7
XATS 377 Cd - XATS 800 CD7
XAHS 347 Cd - XAHS 710 CD7
XAVS 307 Cd - XAVS 650 CD7

Engine CAT C7

Atlas Copco

**Instruction Manual
for Portable Compressors**

**XAMS 407 Cd - XAMS 850 CD7
XATS 377 Cd - XATS 800 CD7
XAHS 347 Cd - XAHS 710 CD7
XAVS 307 Cd - XAVS 650 CD7**

Printed matter N°
2954 3190 01

05/2008

The Atlas Copco logo consists of a thick black horizontal bar above the stylized text 'Atlas Copco' in a serif font, which is itself above another thick black horizontal bar.

ATLAS COPCO - PORTABLE AIR DIVISION
www.atlascopco.com

Warranty and Liability Limitation

Use only authorized parts.

Any damage or malfunction caused by the use of unauthorized parts is not covered by Warranty or Product Liability.

The manufacturer does not accept any liability for any damage arising for modifications, additions or conversions made without the manufacturer's approval in writing.

While every effort has been made to ensure that the information in this manual is correct, Atlas Copco does not assume responsibility for possible errors.

Copyright 2008, Atlas Copco Airpower n.v., Antwerp, Belgium.

Any unauthorized use or copying of the contents or any part thereof is prohibited.

This applies in particular to trademarks, model denominations, part numbers and drawings.

Preface

Please read the following instructions carefully before starting to use your compressor.

It is a solid, safe and reliable machine, built according to the latest technology. Follow the instructions in this booklet and we guarantee you years of troublefree operation.

Always keep the manual available near the machine.

In all correspondence always mention the compressor type and serial number, shown on the data plate.

The company reserves the right to make changes without prior notice.

Table of contents

1	Safety precautions	5
1.1	Introduction	5
1.2	General safety precautions	6
1.3	Safety during transport and installation	7
1.4	Safety during use and operation	7
1.5	Safety during maintenance and repair	9
1.6	Tool applications safety	10
1.7	Specific safety precautions	11
2	Leading particulars	12
2.1	General description	12
3	Main Parts	14
3.1	Compressor regulating system	16
3.1.1	Overview	16
3.1.2	Air flow	18
3.1.3	Oil system	19
3.1.4	Continuous regulating system	20
3.2	Electric system	22
3.3	Markings and information labels	26
4	Operating instructions	27
4.1	Parking, towing and lifting instructions	27
4.1.1	Parking instructions	27
4.1.2	Towing instructions	28
4.1.3	Height adjustment	29
4.1.4	Lifting instructions	29
4.2	Starting / Stopping	30
4.3	Before starting	30
4.3.1	Battery switch	31
4.3.2	Control panel	32
4.3.3	Xc2002™ module	32

4.3.4	Xc2002™ Menu Overview	33
4.3.5	Xc2002™ Menu Description	37
4.3.6	During operation	39
4.3.7	Operations overview	39
4.3.8	Power ON / OFF	40
4.3.9	Starting	40
4.3.10	Warming up	40
4.3.11	Loading	40
4.3.12	Stopping	41
4.3.13	Emergency stop	41
4.3.14	Fault codes	42
5	Maintenance	43
5.1	Liability	43
5.2	Service paks	43
5.3	Service kits	43
5.4	Storage	43
5.5	Preventive maintenance schedule for the compressor	44
5.6	Oil specifications	47
5.6.1	Compressor oil	47
5.6.2	Engine oil	48
5.7	Oil level check	49
5.7.1	Check engine oil level	49
5.7.2	Check compressor oil level	49
5.8	Oil and oil filter change	50
5.8.1	Engine oil and oil filter change	50
5.8.2	Compressor oil and oil filter change	50
5.8.3	Topping up the compressor oil	51
5.9	Coolant specifications	51
5.9.1	PARCOOL EG	52
5.9.2	Handling PARCOOL EG	53
5.10	Coolant check	53
5.11	Topping up/replacing coolant	53

CALIFORNIA Proposition 65 Warning

Diesel engine exhaust and some of its constituents are known to the State of California to cause cancer, birth defects, and other reproductive harm.

5.11.1	Topping up without draining from the cooling system.....	54	7	Problem solving	66
5.11.2	Topping up after limited quantity draining from the cooling system.....	55	8	Available options	69
5.11.3	Replacing the coolant.....	56	9	Technical specifications	71
5.11.4	Cleaning coolers.....	56	9.1	Torque values	71
5.12	Battery care.....	57	9.1.1	General torque values	71
5.12.1	Electrolyte	57	9.1.2	Critical torque values	71
5.12.2	Activating a dry-charged battery.....	57	9.2	Compressor / engine specifications.....	72
5.12.3	Recharging a battery	57	9.2.1	Reference conditions.....	72
5.12.4	Battery maintenance.....	57	9.2.2	Limitations	72
5.13	Compressor element overhaul	57	9.2.3	Altitude unit performance curve	73
6	Adjustments and servicing procedures ..	58	9.2.4	Altitude unit performance curve	74
6.1	Adjustment of the continuous regulating system.....	58	9.2.5	Performance data	75
6.2	Air filter engine/compressor.....	59	9.2.6	Design data.....	77
6.2.1	Servicing	59	10	Dataplate	79
6.2.2	Main parts	59	11	Legislation Size 2 LP	80
6.2.3	Cleaning the dust trap	59	11.1	Parts, subjected to Pressure Equipment Directive 97/23/EC, cat. II and above.....	80
6.2.4	Cleaning instructions filter element	59	11.2	Parts, subjected to Simple Pressure Vessel Directive 87/404/EC.....	80
6.2.5	Replacing the air filter element.....	60	11.3	Parts, subjected to cat. I and covered by the Machine Directive 89/392/EC.....	81
6.2.6	Air receiver.....	61	11.4	Parts, subjected to art. I, paragraph 3.3	81
6.3	Safety valve	61	12	Disposal	82
6.4	Fuel system.....	61	12.1	General	82
6.4.1	Priming instructions	61	12.2	Disposal of materials.....	82
6.4.2	Draining instructions	62	13	Maintenance Log	83
6.5	Brake adjustment.....	63			
6.5.1	Brake shoe adjustment	63			
6.5.2	Audit procedure of brake cable adjustment	64			
6.5.3	Brake cable adjustment	65			
6.5.4	Test procedure of brake cable adjustment	65			

Safety precautions



To be read attentively and acted accordingly before towing, lifting, operating, performing maintenance or repairing the compressor.

INTRODUCTION

The policy of Atlas Copco is to provide the users of their equipment with safe, reliable and efficient products. Factors taken into account are among others:

- the intended and predictable future use of the products, and the environments in which they are expected to operate,
- applicable rules, codes and regulations,
- the expected useful product life, assuming proper service and maintenance,
- providing the manual with up-to-date information.

Before handling any product, take time to read the relevant instruction manual. Besides giving detailed operating instructions, it also gives specific information about safety, preventive maintenance, etc.

Keep the manual always at the unit location, easy accessible to the operating personnel.

See also the safety precautions of the engine and possible other equipment, which are separately sent along or are mentioned on the equipment or parts of the unit.

These safety precautions are general and some statements will therefore not always apply to a particular unit.

Only people that have the right skills should be allowed to operate, adjust, perform maintenance or repair on Atlas Copco equipment.

It is the responsibility of management to appoint operators with the appropriate training and skill for each category of job.

Skill level 1: Operator

An operator is trained in all aspects of operating the unit with the push-buttons, and is trained to know the safety aspects.

Skill level 2: Mechanical technician

A mechanical technician is trained to operate the unit the same as the operator. In addition, the mechanical technician is also trained to perform maintenance and repair, as described in the instruction manual, and is allowed to change settings of the control and safety system. A mechanical technician does not work on live electrical components.

Skill level 3: Electrical technician

An electrical technician is trained and has the same qualifications as both the operator and the mechanical technician. In addition, the electrical technician may carry out electrical repairs within the various enclosures of the unit. This includes work on live electrical components.

Skill level 4: Specialist from the manufacturer

This is a skilled specialist sent by the manufacturer or its agent to perform complex repairs or modifications to the equipment.

In general it is recommended that not more than two people operate the unit, more operators could lead to unsafe operating conditions.

Take necessary steps to keep unauthorized persons away from the unit and eliminate all possible sources of danger at the unit.

When handling, operating, overhauling and/or performing maintenance or repair on Atlas Copco equipment, the mechanics are expected to use safe engineering practices and to observe all relevant local safety requirements and ordinances. The following list is a reminder of special safety directives and precautions mainly applicable to Atlas Copco equipment.

These safety precautions apply to machinery processing or consuming air. Processing of any other gas requires additional safety precautions typical to the application and are not included herein.

Neglecting the safety precautions may endanger people as well as environment and machinery:

- endanger people due to electrical, mechanical or chemical influences,
- endanger the environment due to leakage of oil, solvents or other substances,
- endanger the machinery due to function failures.

All responsibility for any damage or injury resulting from neglecting these precautions or by non-observance of ordinary caution and due care required in handling, operating, maintenance or repair, also if not expressly mentioned in this instruction manual, is disclaimed by Atlas Copco.

The manufacturer does not accept any liability for any damage arising from the use of non-original parts and for modifications, additions or conversions made without the manufacturer's approval in writing.

If any statement in this manual does not comply with local legislation, the stricter of the two shall be applied.

Statements in these safety precautions should not be interpreted as suggestions, recommendations or inducements that it should be used in violation of any applicable laws or regulations.

GENERAL SAFETY PRECAUTIONS

- 1 The owner is responsible for maintaining the unit in a safe operating condition. Unit parts and accessories must be replaced if missing or unsuitable for safe operation.
- 2 The supervisor, or the responsible person, shall at all times make sure that all instructions regarding machinery and equipment operation and maintenance are strictly followed and that the machines with all accessories and safety devices, as well as the consuming devices, are in good repair, free of abnormal wear or abuse, and are not tampered with.
- 3 Whenever there is an indication or any suspicion that an internal part of a machine is overheated, the machine shall be stopped but no inspection covers shall be opened before sufficient cooling time has elapsed; this to avoid the risk of spontaneous ignition of oil vapour when air is admitted.
- 4 Normal ratings (pressures, temperatures, speeds, etc.) shall be durably marked.
- 5 Operate the unit only for the intended purpose and within its rated limits (pressure, temperature, speeds, etc.).
- 6 The machinery and equipment shall be kept clean, i.e. as free as possible from oil, dust or other deposits.
- 7 To prevent an increase in working temperature, inspect and clean heat transfer surfaces (cooler fins, intercoolers, water jackets, etc.) regularly. See the **Preventive maintenance schedule for the compressor**.
- 8 All regulating and safety devices shall be maintained with due care to ensure that they function properly. They may not be put out of action.
- 9 Care shall be taken to avoid damage to safety valves and other pressure-relief devices, especially to avoid plugging by paint, oil coke or dirt accumulation, which could interfere with the functioning of the device.
- 10 Pressure and temperature gauges shall be checked regularly with regard to their accuracy. They shall be replaced whenever outside acceptable tolerances.
- 11 Safety devices shall be tested as described in the maintenance schedule of the instruction manual to determine that they are in good operating condition. See the **Preventive maintenance schedule for the compressor**.
- 12 Mind the markings and information labels on the unit.
- 13 In the event the safety labels are damaged or destroyed, they must be replaced to ensure operator safety.
- 14 Keep the work area neat. Lack of order will increase the risk of accidents.
- 15 When working on the unit, wear safety clothing. Depending on the kind of activities these are: safety glasses, ear protection, safety helmet (including visor), safety gloves, protective clothing, safety shoes. Do not wear the hair long and loose (protect long hair with a hairnet), or wear loose clothing or jewelry.
- 16 Take precautions against fire. Handle fuel, oil and anti-freeze with care because they are inflammable substances. Do not smoke or approach with naked flame when handling such substances. Keep a fire-extinguisher in the vicinity.

SAFETY DURING TRANSPORT AND INSTALLATION

When towing, lifting or transporting the compressor in any way, the battery switch must always be in the "OFF" position!

To lift a unit, all loose or pivoting parts, e.g. doors and towbar, shall first be securely fastened.

Do not attach cables, chains or ropes directly to the lifting eye; apply a crane hook or lifting shackle meeting local safety regulations. Never allow sharp bends in lifting cables, chains or ropes.

Helicopter lifting is not allowed.

It is strictly forbidden to dwell or stay in the risk zone under a lifted load. Never lift the unit over people or residential areas. Lifting acceleration and retardation shall be kept within safe limits.

1 Before towing the unit:

- ascertain that the pressure vessel(s) is (are) depressurized,
- check the towbar, the brake system and the towing eye. Also check the coupling of the towing vehicle,
- check the towing and brake capability of the towing vehicle,
- check that the towbar, jockey wheel or stand leg is safely locked in the raised position,
- ascertain that the towing eye can swivel freely on the hook,
- check that the wheels are secure and that the tyres are in good condition and inflated correctly,
- connect the signalisation cable, check all lights and connect the pneumatic brake couplers,
- attach the safety break-away cable or safety chain to the towing vehicle,

- remove wheel chocks, if applied, and disengage the parking brake.
- 2 To tow a unit use a towing vehicle of ample capacity. Refer to the documentation of the towing vehicle.
 - 3 If the unit is to be backed up by the towing vehicle, disengage the overrun brake mechanism (if it is not an automatic mechanism).
 - 4 Never exceed the maximum towing speed of the unit (mind the local regulations).
 - 5 Place the unit on level ground and apply the parking brake before disconnecting the unit from the towing vehicle. Unclip the safety break-away cable or safety chain. If the unit has no parking brake or jockey wheel, immobilize the unit by placing chocks in front of and/or behind the wheels. When the towbar can be positioned vertically, the locking device must be applied and kept in good order.
 - 6 To lift heavy parts, a hoist of ample capacity, tested and approved according to local safety regulations, shall be used.
 - 7 Lifting hooks, eyes, shackles, etc., shall never be bent and shall only have stress in line with their design load axis. The capacity of a lifting device diminishes when the lifting force is applied at an angle to its load axis.
 - 8 For maximum safety and efficiency of the lifting apparatus all lifting members shall be applied as near to perpendicular as possible. If required, a lifting beam shall be applied between hoist and load.
 - 9 Never leave a load hanging on a hoist.
 - 10 A hoist has to be installed in such a way that the object will be lifted perpendicular. If that is not possible, the necessary precautions must be taken to prevent load-swinging, e.g. by using two

hoists, each at approximately the same angle not exceeding 30° from the vertical.

- 11 Locate the unit away from walls. Take all precautions to ensure that hot air exhausted from the engine and driven machine cooling systems cannot be recirculated. If such hot air is taken in by the engine or driven machine cooling fan, this may cause overheating of the unit; if taken in for combustion, the engine power will be reduced.
- 12 Before moving the compressor, switch it off.
- 13 If the warning light on the ABS module or in the vehicle lights up, please contact Atlas Copco.

SAFETY DURING USE AND OPERATION

- 1 When the unit has to operate in a fire-hazardous environment, each engine exhaust has to be provided with a spark arrestor to trap incendiary sparks.
- 2 The exhaust contains carbon monoxide which is a lethal gas. When the unit is used in a confined space, conduct the engine exhaust to the outside atmosphere by a pipe of sufficient diameter; do this in such a way that no extra back pressure is created for the engine. If necessary, install an extractor. Observe any existing local regulations. Make sure that the unit has sufficient air intake for operation. If necessary, install extra air intake ducts.
- 3 When operating in a dust-laden atmosphere, place the unit so that dust is not carried towards it by the wind. Operation in clean surroundings considerably extends the intervals for cleaning the air intake filters and the cores of the coolers.

- 4 Close the compressor air outlet valve before connecting or disconnecting a hose. Ascertain that a hose is fully depressurized before disconnecting it. Before blowing compressed air through a hose or air line, ensure that the open end is held securely, so that it cannot whip and cause injury.
- 5 The air line end connected to the outlet valve must be safeguarded with a safety cable, attached next to the valve.
- 6 No external force may be exerted on the air outlet valves, e.g. by pulling on hoses or by installing auxiliary equipment directly to a valve, e.g. a water separator, a lubricator, etc. Do not step on the air outlet valves.
- 7 Never move a unit when external lines or hoses are connected to the outlet valves, to avoid damage to valves, manifold and hoses.
- 8 Do not use compressed air from any type of compressor, without taking extra measures, for breathing purposes as this may result in injury or death. For breathing air quality, the compressed air must be adequately purified according to local legislation and standards. Breathing air must always be supplied at stable, suitable pressure.
- 9 Distribution pipework and air hoses must be of correct diameter and suitable for the working pressure. Never use frayed, damaged or deteriorated hoses. Replace hoses and flexibles before the lifetime expires. Use only the correct type and size of hose end fittings and connections.
- 10 If the compressor is to be used for sand-blasting or will be connected to a common compressed-air system, fit an appropriate non-return valve (check valve) between compressor outlet and the connected sand-blasting or compressed-air system. Observe the right mounting position/direction.
 - 11 Before removing the oil filler plug, ensure that the pressure is released by opening an air outlet valve.
 - 12 Never remove a filler cap of the cooling water system of a hot engine. Wait until the engine has sufficiently cooled down.
 - 13 Never refill fuel while the unit is running, unless otherwise stated in the Atlas Copco Instruction Book (AIB). Keep fuel away from hot parts such as air outlet pipes or the engine exhaust. Do not smoke when fuelling. When fuelling from an automatic pump, an earthing cable should be connected to the unit to discharge static electricity. Never spill nor leave oil, fuel, coolant or cleansing agent in or around the unit.
 - 14 All doors shall be shut during operation so as not to disturb the cooling air flow inside the bodywork and/or render the silencing less effective. A door should be kept open for a short period only e.g. for inspection or adjustment.
 - 15 Periodically carry out maintenance works according to the maintenance schedule.
 - 16 Stationary housing guards are provided on all rotating or reciprocating parts not otherwise protected and which may be hazardous to personnel. Machinery shall never be put into operation, when such guards have been removed, before the guards are securely reinstalled.
 - 17 Noise, even at reasonable levels, can cause irritation and disturbance which, over a long period of time, may cause severe injuries to the nervous system of human beings. When the sound pressure level, at any point where personnel normally has to attend, is:
 - below 70 dB(A): no action needs to be taken,
 - above 70 dB(A): noise-protective devices should be provided for people continuously being present in the room,
 - below 85 dB(A): no action needs to be taken for occasional visitors staying a limited time only,
 - above 85 dB(A): room to be classified as a noise-hazardous area and an obvious warning shall be placed permanently at each entrance to alert people entering the room, for even relatively short times, about the need to wear ear protectors,
 - above 95 dB(A): the warning(s) at the entrance(s) shall be completed with the recommendation that also occasional visitors shall wear ear protectors,
 - above 105 dB(A): special ear protectors that are adequate for this noise level and the spectral composition of the noise shall be provided and a special warning to that effect shall be placed at each entrance.
 - 18 The unit has parts, which may be accidentally touched by personnel, of which the temperature can be in excess of 80 °C (176 °F). The insulation or safety guard, protecting these parts shall not be removed before the parts have cooled down to room temperature.
 - 19 Never operate the unit in surroundings where there is a possibility of taking in flammable or toxic fumes.
 - 20 If the working process produces fumes, dust or vibration hazards, etc., take the necessary steps to eliminate the risk of personnel injury.
 - 21 When using compressed air or inert gas to clean down equipment, do so with caution and use the appropriate protection, at least safety glasses, for the operator as well as for any bystander. Do not apply compressed air or inert gas to your skin or direct an air or gas stream at people. Never use it to clean dirt from your clothes.

- 22 When washing parts in or with a cleaning solvent, provide the required ventilation and use appropriate protection such as a breathing filter, safety glasses, rubber apron and gloves, etc.
- 23 Safety shoes should be compulsory in any workshop and if there is a risk, however small, of falling objects, wearing of a safety helmet should be included.
- 24 If there is a risk of inhaling hazardous gases, fumes or dust, the respiratory organs must be protected and depending on the nature of the hazard, so must the eyes and skin.
- 25 Remember that where there is visible dust, the finer, invisible particles will almost certainly be present too; but the fact that no dust can be seen is not a reliable indication that dangerous, invisible dust is not present in the air.
- 26 Never operate the unit at pressures or speeds below or in excess of its limits as indicated in the technical specifications.
- 27 Do not use aerosol types of starting aids such as ether. Such use could result in an explosion and personal injury.

SAFETY DURING MAINTENANCE AND REPAIR

Maintenance, overhaul and repair work shall only be carried out by adequately trained personnel; if required, under supervision of someone qualified for the job.

- 1 Use only the correct tools for maintenance and repair work, and only tools which are in good condition.
- 2 Parts shall only be replaced by genuine Atlas Copco replacement parts.
- 3 All maintenance work, other than routine attention, shall only be undertaken when the unit is stopped. Steps shall be taken to prevent inadvertent starting. In addition, a warning sign bearing a legend such as "work in progress; do not start" shall be attached to the starting equipment. On engine-driven units the battery shall be disconnected and removed or the terminals covered by insulating caps. On electrically driven units the main switch shall be locked in open position and the fuses shall be taken out. A warning sign bearing a legend such as "work in progress; do not supply voltage" shall be attached to the fuse box or main switch.
- 4 Before dismantling any pressurized component, the compressor or equipment shall be effectively isolated from all sources of pressure and the entire system shall be relieved of pressure. Do not rely on non-return valves (check valves) to isolate pressure systems. In addition, a warning sign bearing a legend such as "work in progress; do not open" shall be attached to each of the outlet valves.
- 5 Prior to stripping an engine or other machine or undertaking major overhaul on it, prevent all movable parts from rolling over or moving.

- 6 Make sure that no tools, loose parts or rags are left in or on the machine. Never leave rags or loose clothing near the engine air intake.
- 7 Never use flammable solvents for cleaning (fire-risk).
- 8 Take safety precautions against toxic vapours of cleaning liquids.
- 9 Never use machine parts as a climbing aid.
- 10 Observe scrupulous cleanliness during maintenance and repair. Keep away dirt, cover the parts and exposed openings with a clean cloth, paper or tape.
- 11 Never weld on or perform any operation involving heat near the fuel or oil systems. Fuel and oil tanks must be completely purged, e.g. by steam-cleaning, before carrying out such operations. Never weld on, or in any way modify, pressure vessels. Disconnect the alternator cables during arc welding on the unit.
- 12 Support the towbar and the axle(s) securely if working underneath the unit or when removing a wheel. Do not rely on jacks.
- 13 Do not remove any of, or tamper with, the sound-damping material. Keep the material free of dirt and liquids such as fuel, oil and cleansing agents. If any sound-damping material is damaged, replace it to prevent the sound pressure level from increasing.
- 14 Use only lubricating oils and greases recommended or approved by Atlas Copco or the machine manufacturer. Ascertain that the selected lubricants comply with all applicable safety regulations, especially with regard to explosion or fire-risk and the possibility of decomposition or generation of hazardous gases. Never mix synthetic with mineral oil.

- 15 Protect the engine, alternator, air intake filter, electrical and regulating components, etc., to prevent moisture ingress, e.g. when steam-cleaning.
- 16 When performing any operation involving heat, flames or sparks on a machine, the surrounding components shall first be screened with non-flammable material.
- 17 Never use a light source with open flame for inspecting the interior of a machine.
- 18 Disconnect –battery-clamp before starting electrical servicing or welding (or turn battery-switch in “off” position).
- 19 When repair has been completed, the machine shall be barred over at least one revolution for reciprocating machines, several revolutions for rotary ones to ensure that there is no mechanical interference within the machine or driver. Check the direction of rotation of electric motors when starting up the machine initially and after any alteration to the electrical connection(s) or switch gear, to check that the oil pump and the fan function properly.
- 20 Maintenance and repair work should be recorded in an operator’s logbook for all machinery. Frequency and nature of repairs can reveal unsafe conditions.
- 21 When hot parts have to be handled, e.g. shrink fitting, special heat-resistant gloves shall be used and, if required, other body protection shall be applied.
- 22 When using cartridge type breathing filter equipment, ascertain that the correct type of cartridge is used and that its useful service life is not surpassed.
- 23 Make sure that oil, solvents and other substances likely to pollute the environment are properly disposed of.
- 24 Before clearing the unit for use after maintenance or overhaul, check that operating pressures, temperatures and speeds are correct and that the control and shutdown devices function correctly.

TOOL APPLICATIONS SAFETY

Apply the proper tool for each job. With the knowledge of correct tool use and knowing the limitations of tools, along with some common sense, many accidents can be prevented.

Special service tools are available for specific jobs and should be used when recommended. The use of these tools will save time and prevent damage to parts.

SPECIFIC SAFETY PRECAUTIONS

Batteries

When servicing batteries, always wear protecting clothing and glasses.

- 1 The electrolyte in batteries is a sulphuric acid solution which is fatal if it hits your eyes, and which can cause burns if it contacts your skin. Therefore, be careful when handling batteries, e.g. when checking the charge condition.
- 2 Install a sign prohibiting fire, open flame and smoking at the post where batteries are being charged.
- 3 When batteries are being charged, an explosive gas mixture forms in the cells and might escape through the vent holes in the plugs. Thus an explosive atmosphere may form around the battery if ventilation is poor, and can remain in and around the battery for several hours after it has been charged. Therefore:
 - never smoke near batteries being, or having recently been, charged,
 - never break live circuits at battery terminals, because a spark usually occurs.
- 4 When connecting an auxiliary battery (AB) in parallel to the unit battery (CB) with booster cables: connect the + pole of AB to the + pole of CB, then connect the - pole of CB to the mass of the unit. Disconnect in the reverse order.

Pressure vessels

Maintenance/installation requirements:

- 1 The vessel can be used as pressure vessel or as separator and is designed to hold compressed air for the following application:
 - pressure vessel for compressor,
 - medium AIR/OIL,
 - and operates as detailed on the data plate of the vessel:
 - the maximum working pressure ps in bar (psi),
 - the maximum working temperature Tmax in °C (°F),
 - the minimum working temperature Tmin in °C (°F),
 - the capacity of the vessel V in l (US gal, Imp gal, cu.ft).
- 2 The pressure vessel is only to be used for the applications as specified above and in accordance with the technical specifications. Safety reasons prohibit any other applications.
- 3 National legislation requirements with respect to re-inspection must be complied with.
- 4 No welding or heat treatment of any kind is permitted to those vessel walls which are exposed to pressure.
- 5 The vessel is provided and may only be used with the required safety equipment such as manometer, overpressure control devices, safety valve, etc.
- 6 Draining of condensate shall be performed daily when vessel is in use.
- 7 Installation, design and connections should not be changed.
- 8 Bolts of cover and flanges may not be used for extra fixation.

Safety valves

Operating & Maintenance

Only trained and technically competent personnel should consider overhaul, re-set or performance testing of safety valves.

The safety valve is supplied with either a lead security seal or crimped cover to deter unauthorised access to the pressure regulation device.

Under no circumstances should the set pressure of the safety valve be altered to a different pressure than that stamped on the valve without the permission of the installation designer.

If the set pressure must be altered then use only correct parts supplied by Atlas Copco and in accordance with the instructions available for the valve type.

Safety valves must be frequently tested and regularly maintained.

The set pressure should be periodically checked for accuracy.

When fitted, the compressors should be operated at pressures not less than 75% of the set pressure to ensure free and easy movement of internal parts.

The frequency of tests is influenced by factors such as the severity of the operating environment and aggressiveness of the pressurised medium.

Soft seals and springs should be replaced as part of the maintenance procedure.

Do not paint or coat the installed safety valve (see also **Preventive maintenance schedule for the compressor**).

Leading particulars

GENERAL DESCRIPTION

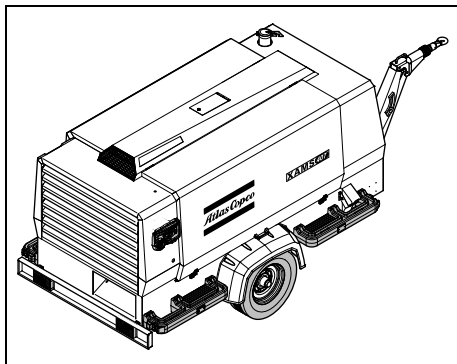

The XAMS 407 Cd - XAMS 850 CD7 is a silenced, single-stage, oil-injected screw compressor, built for a nominal effective working pressure of 8.6 bar (125 psi).

The XATS 377 Cd - XATS 800 CD7 is a silenced, single-stage, oil-injected screw compressor, built for a nominal effective working pressure of 10.3 bar (150 psi).

The XAHS 347 Cd - XAHS 710 CD7 is a silenced, single-stage, oil-injected screw compressor, built for a nominal effective working pressure of 12 bar (175 psi).

The XAVS 307 Cd - XAVS 650 CD7 is a silenced, single-stage, oil-injected screw compressor, built for a nominal effective working pressure of 14 bar (200 psi).

Engine

The compressors XAMS 407 Cd - XAMS 850 CD7, XATS 377 Cd - XATS 800 CD7, XAHS 347 Cd - XAHS 710 CD7 and XAVS 307 Cd - XAVS 650 CD7 are driven by 6 cylinder in-line liquid-cooled diesel engines.

The engine's power is transmitted to the compressor element through a heavy-duty coupling.

Compressor

The compressor casing houses two screw-type rotors, mounted on ball and roller bearings. The male rotor, driven by the engine, drives the female rotor. The compressor delivers pulsation-free air.

Injected oil is used for sealing, cooling and lubricating purposes.

Compressor oil system

The oil is boosted by air pressure. The system has no oil pump.

The oil is removed from the air, in the air/oil vessel at first by centrifugal force, secondly through the oil separator element.

The vessel is provided with an oil level indicator.

Regulation

The compressor is provided with a continuous regulating system and a blow-off valve which is integrated in the unloader assembly. The valve is closed during operation by air receiver pressure and opens by air receiver pressure via the compressor element when the compressor is stopped.

When the air consumption increases, the air receiver pressure will decrease and vice versa.

This receiver pressure variation is sensed by the regulating valve which, by means of control air to the unloader and an electronic engine speed regulator, matches the air output to the air consumption. The air receiver pressure is maintained between the pre-selected working pressure and the corresponding unloading pressure.

Cooling system

The engine is provided with a liquid-cooler and intercooler and the compressor is provided with an oil cooler. For available options see chapter **Available options**.

The cooling air is generated by a fan, driven by the engine.

Safety devices

A thermal shut-down sensor protects the compressor against overheating. The air receiver is provided with a safety valve.

The engine is equipped with low oil pressure and high coolant temperature shut-down sensors.

The electric system is equipped with a 24V main switch.

Frame and axles

The compressor/engine unit is supported by rubber buffers in the frame.

The standard compressor has an adjustable or fixed towbar with brakes.

The braking system consists of an integrated parking brake and overrunbrake. When driving backwards the overrunbrake is not engaged automatically. (For available options see chapter **Available options**.)

Bodywork

The bodywork has openings at the shaped front and rear end for the intake air and outlet of cooling air and hinged doors for maintenance and service operations. The bodywork is internally lined with sound-absorbing material.

Lifting eye

A lifting eye is accessible when a small door at the top of the unit is unlocked.

Control panel

The control panel grouping the air pressure gauge, control switch etc., is placed at the left hand/ rear end corner.

Data plate

The compressor is furnished with a data plate showing the product code, the unit serial number and the working pressure (see chapter **Dataplate**).

Serial number

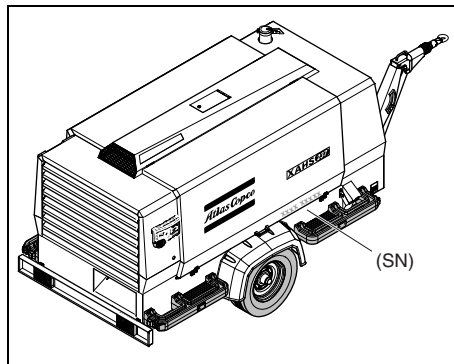

The serial number (SN) is located on the right-hand side towards the front on the upper edge of the frame.

Main Parts

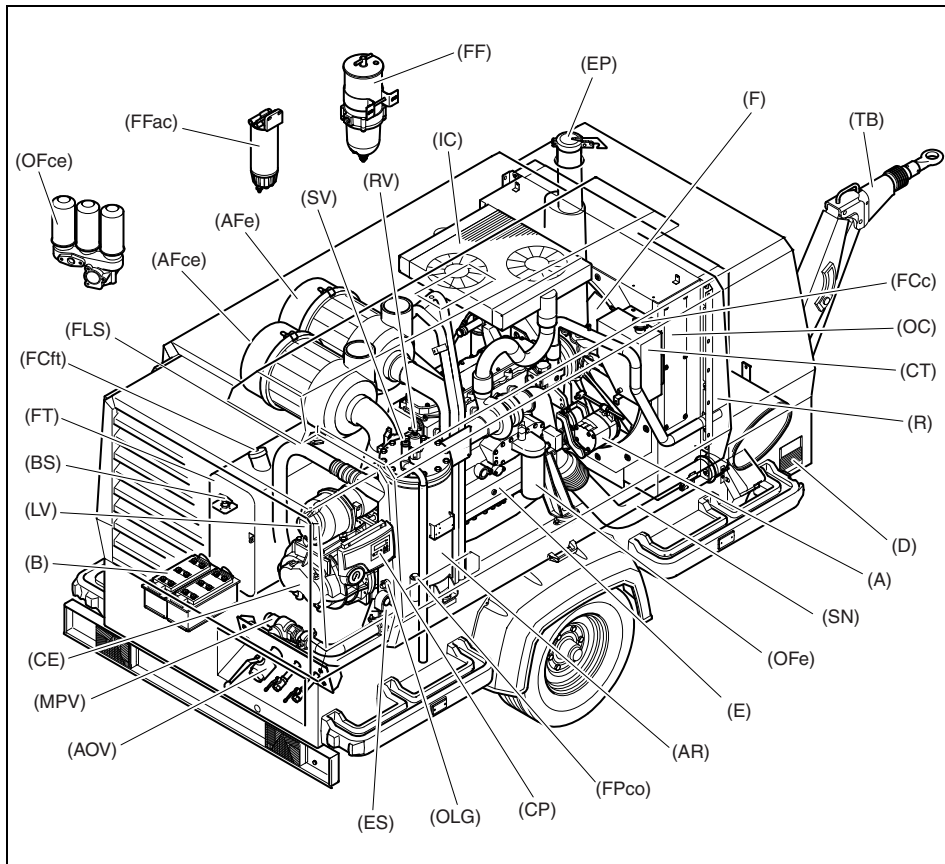

Reference	Name
A	Alternator
AFce	Air Filter (compressor element)
AFe	Air Filter (engine)
AOV	Air Outlet Valves
AR	Air Receiver
B	Battery
BS	Battery Switch
CE	Compressor Element
CP	Control Panel
CT	Coolant Tank
D	Data plate
E	Engine
EP	Exhaust Pipe
ES	Emergency Stop
F	Fan
FCft	Filler Cap (fuel tank)
FCc	Filler Cap (coolant)
FF	Fuel Filter
FFac	Fuel Filter AC
FLS	Fuel Level Sensor
FPco	Filler Plug (oil compressor element)

Reference	Name
FT	Fuel Tank
IC	Intercooler
LV	Loading Valve
MPV	Minimum Pressure Valve
OC	Oil Cooler
OFce	Oil Filter (compressor element)
OFe	Oil Filter (engine)
OLG	Oil Level Gauge
R	Radiator
RV	Regulating Valve
SN	Serial Number
SV	Safety Valve
TB	Towbar

COMPRESSOR REGULATING SYSTEM

OVERVIEW

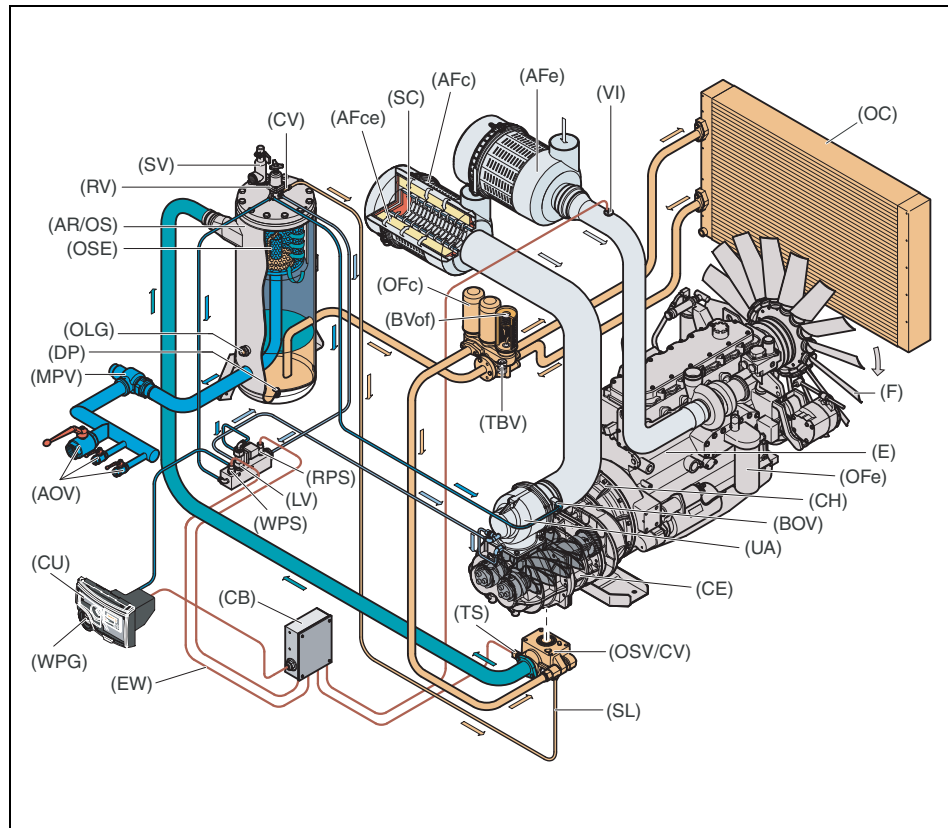

Reference	Name
AFce	Air Filter (compressor element)
AFc	Air Filter (compressor)
AFe	Air Filter (engine)
AOV	Air Outlet Valves
AR/OS	Air Receiver / Oil Separator
BOV	Blow Off Valve
BVof	Bypass Valve oil filter
CB	Cubicle
CE	Compressor Element
CH	Coupling Housing
CU	Control Unit
CV	Check Valve
DP	Drain Plug
E	Engine
EW	Electrical Wiring
F	Fan
LV	Loading Valve
MPV	Minimum Pressure Valve
OC	Oil Cooler
OFc	Oil Filter (compressor)
OFe	Oil Filter (engine)
OLG	Oil Level Gauge
OSE	Oil Separator Element

Reference	Name
OSV/CV	Oil Stop Valve / Check Valve
RPS	Regulating Pressure Sensor
RV	Regulating Valve
SC	Safety Cartridge
SL	Scavenge Line
SV	Safety Valve
TBV	Thermostatic Bypass Valve
TS	Temperature Sensor
UA	Unloader Assembly
VI	Vacuum Indicator
WPG	Working Pressure Gauge
WPS	Working Pressure Sensor

AIR FLOW

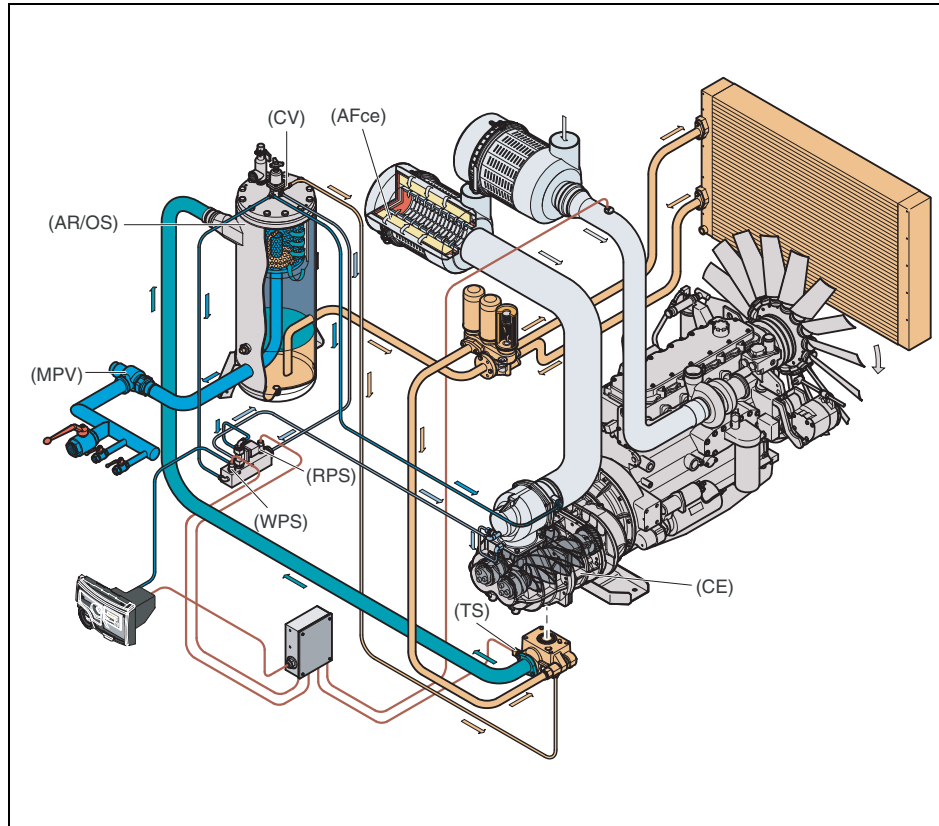

Air drawn through the airfilter (AFce) into the compressor element (CE) is compressed. At the element outlet, compressed air and oil pass into the air receiver/oil separator (AR/OS).

The check valve (CV) prevents blow-back of compressed air when the compressor is stopped. In the air receiver/oil separator (AR/OS), most of the oil is removed from the air/oil mixture.

The oil collects in the receiver and on the bottom of the separator element.

The air leaves the receiver via a minimum pressure valve (MPV) which prevents the receiver pressure from dropping below the minimum working pressure, even when the air outlet valves are open (specified in section **Limitations**). This ensures adequate oil injection and prevents oil consumption. The minimum pressure valve (MPV) also functions as a check valve.

The system comprises temperature sensors (TS), regulating pressure sensors (RPS) and a working pressure sensor (WPS).

OIL SYSTEM

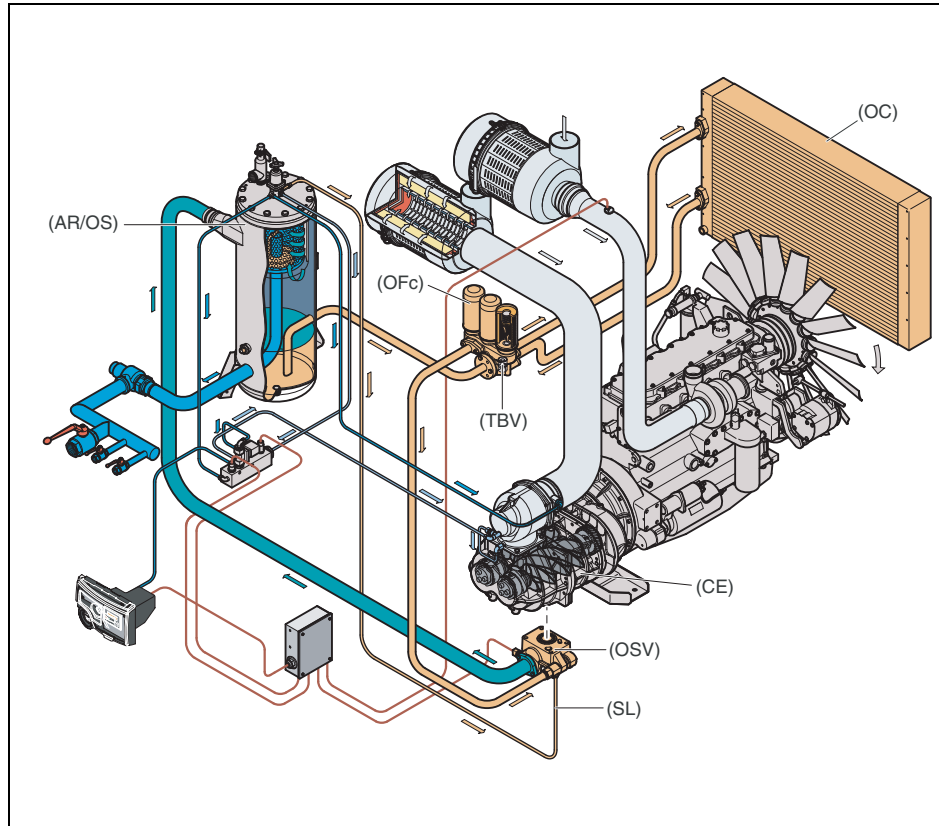

The lower part of the air receiver (AR) serves as oil tank.

Air pressure forces the oil from the air receiver/oil separator (AR/OS) through the oil cooler (OC), the oil filters (OFc) and the oil stop valve (OSV) to the compressor element (CE).

When the compressor is stopped and / or there is no pressure in the system, the oil stop valve (OSV) prevents the oil from flowing back into the compressor element.

The thermostatic by-pass valve (TBV) starts opening when the oil temperature is 80 °C (176 °F).

The compressor element has an oil gallery in the bottom of its casing. The oil for rotor lubrication, cooling and sealing is injected through holes in the gallery.

Lubrication of the bearings is ensured by oil injected into the bearing housings.

The injected oil, mixed with the compressed air, leaves the compressor element and re-enters the air receiver, where it is separated from the air as described in section **Air flow**. The oil that collects in the bottom of the oil separator element is returned to the system through a scavenging line (SL), which is provided with a flow restrictor.

The oil filter by-pass valve opens when the pressure drop over the filter is above normal because of a clogged filter. The oil then by-passes the filter without being filtered. For this reason, the oil filter must be replaced at regular intervals (see section **Preventive maintenance schedule for the compressor**).

CONTINUOUS REGULATING SYSTEM

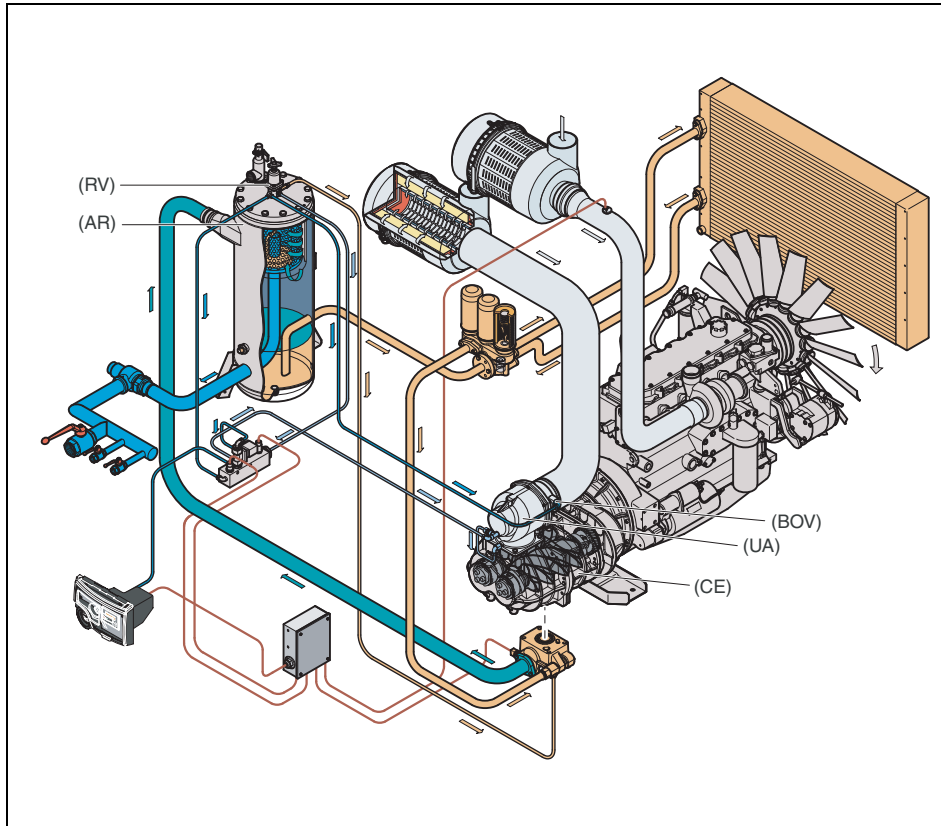

The compressor is provided with a continuous regulating system and a blow-off valve (BOV) which is integrated in the unloader assembly (UA). The valve is closed during operation by outlet pressure of the compressor element and opens by air receiver pressure when the compressor is stopped.

When the air consumption increases, the air receiver pressure will decrease and vice versa. This receiver pressure variation is sensed by the regulating valve (RV) which, by means of control air to the unloader assembly (UA), matches the air output to the air consumption. The air receiver pressure is maintained between the pre-selected working pressure and the corresponding unloading pressure.

When starting the compressor, the throttle valve is kept closed via receiver pressure. The compressor element (CE) takes in air and pressure builds up in the receiver (AR). The throttle valve is closed. The air output is controlled from maximum output (100%) to no output (0%) by:

1. Speed control of the engine between maximum load speed and unloading speed (the output of a screw compressor is proportional to the rotating speed).
2. Air inlet throttling.

If the air consumption is equal to or exceeds the maximum air output, the engine speed is held at maximum load speed and the throttle valve is fully open.

If the air consumption is less than the maximum air output, air receiver pressure increases and the regulating valve supplies control air to throttle valve to reduce the air output and holds air receiver pressure between the normal working pressure and the corresponding unloading pressure. Unloading pressure = normal working pressure + 1 bar (14.504 psi).

When the air consumption is resumed, the blow off valve (BOV) closes and the throttle valve gradually opens the air intake and the electronic speed regulator increases the engine speed.

The construction of the regulating valve (RV) is such that any increase (decrease) of the air receiver pressure above the pre-set valve opening pressure results in a proportional increase (decrease) of the control pressure to the throttle valve and the electronic speed regulator.

Part of the control air is vented to atmosphere, and any condensate discharged, through the vent holes.

ELECTRIC SYSTEM

Circuit diagram C7 engine - part 1 (9822 0937 90)

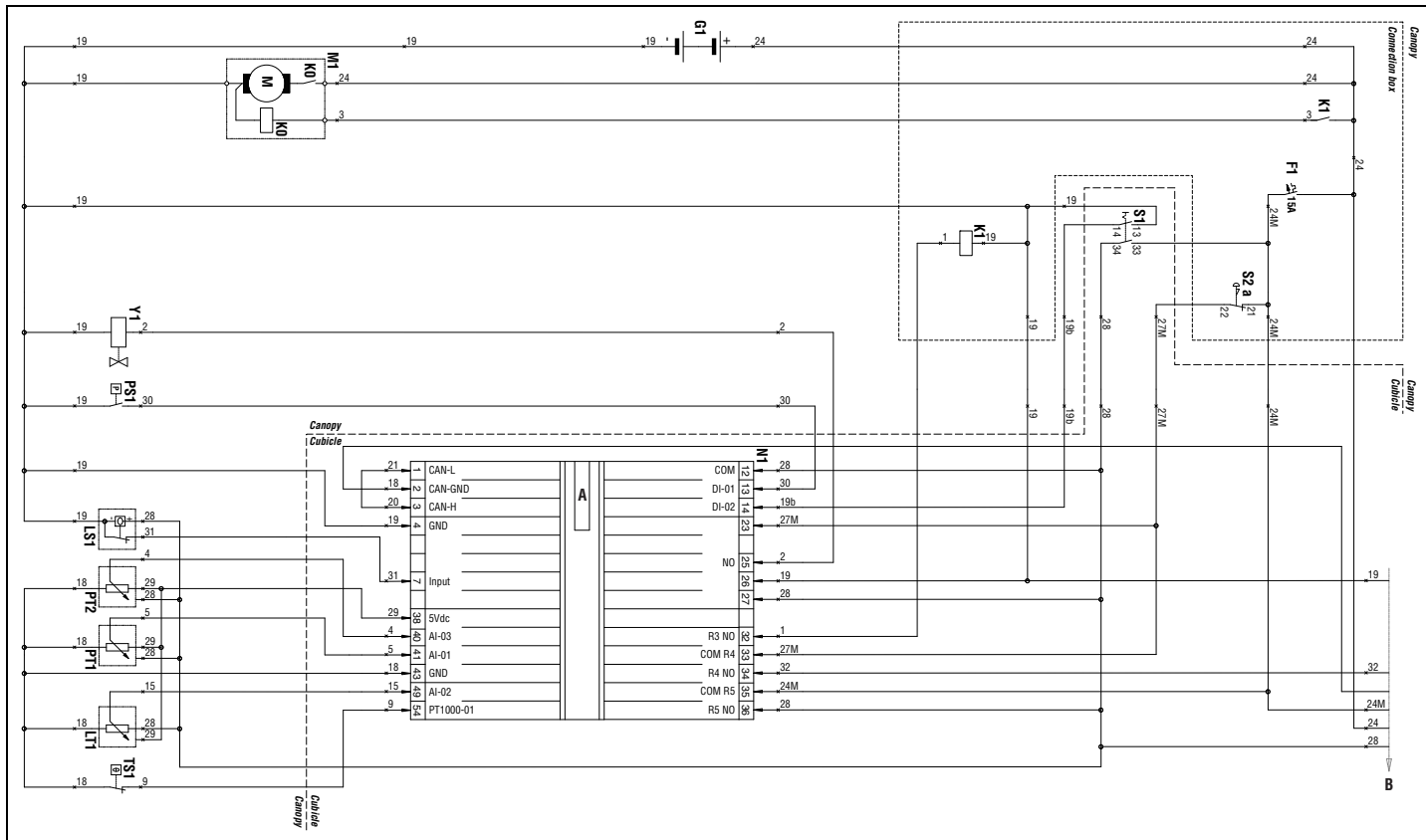

Reference	Name
F1	Circuit Breaker
G1	Battery
K0	Start Relay
K1	Relay - Starter Motor
LS1	Level Switch - Coolant level
LT1	Level Sensor - Fuel Level
M1	Starter Motor
N1	Control Module - Xc2002
PS1	Pressure Switch - Airfilter
PT1	Pressure Sensor - Regulating Pressure
PT2	Pressure Sensor - Vessel Pressure
S1	Main Power Switch
S2	Emergency Stop
TS1	Temperature Switch
	Compressor Element Temperature
Y1	Loading Valve
A	Communication port
B	To machine type specific diagrams

Reference	Name
1 CAN-L	CAN LOW
2 CAN-GND	CAN Shield
3 CAN-H	CAN High
4 GND	Common for 5..7 (GND)
7 Input	Low Coolant Shutdown
12 COM	Common for 13..18 (24Vdc)
13 DI-01	Airfilter Switch
14 DI-02	ON
23	Common for 24, 25, 32 (24Vdc)
25 NO	Loading Valve
26	GND (Batt-)
27	12/24 Vdc (Batt+)
32 R3 NO	Start Relay Output
33 COM R4	Common for 34 (24Vdc)
34 R4 NO	Power After Contact
35 COM R5	Common for 35 (24Vdc)
36 R5 NO	ON contact
38 5Vdc	Sensor Supply (5Vdc)
40 AI-03	Vessel Pressure
41 AI-01	Regulating Pressure
43 GND	Sensor GND
49 AI-02	Fuel Level
54 PT1000-01	Element temperature



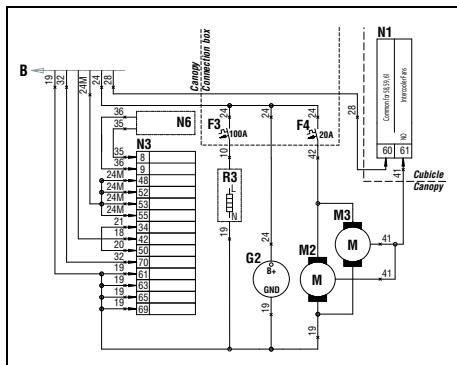









Circuit diagram C7 engine - part 2





















Reference	Name
M2-3	Intercooler fans
F3	Circuit breaker - Grid heater
F4	Circuit breaker intercooler fans
G2	Alternator
N1	Control module - Xc2002
N3	Electronic control unit - Engine
N6	Caterpillar diagnostic connector
R3	Grid heater
B	to main circuit diagram

Reference	Name
8	CDL +
9	CDL -
48	Battery +
52	Battery +
53	Battery +
55	Battery +
34	CAN low
42	CAN shield
50	CAN high
70	Key switch input
61	Battery -
63	Battery -
65	Battery -
69	Battery -

MARKINGS AND INFORMATION LABELS

	Dangerous outlet gases.
	Danger, hot surface.
	Electrocution hazard.
 PAROIL S	Atlas Copco synthetic compressor oil.
 PAROIL SAE 15W40	Atlas Copco mineral engine oil.
	Manual.
	Read the instruction manual before working on the battery.
	Reset fuse.
	On / off button.
	Prohibition to open air valves without connected hoses.
	Rotation direction.
	Inlet.

	Outlet.
	Compressor oil drain.
	Read the instruction manual before starting.
	Service every 24 hours.
	Warning! Part under pressure.
	Do not stand on outlet valves.
	Start-Stop indication of switch.
	Do not run the compressor with open doors.
	Lifting permitted.
 diesel	Use diesel fuel only.
4 bar (58 psi)	Tyre pressure.
6 bar (87 psi)	Tyre pressure.

	Sound power level in accordance with Directive 2000/14/EC (expressed in dB (A)).
	Fork lifting permitted.
	Don't lift here.
	Read the instruction manual before lifting.
	Filler cap coolant.
	Read the instruction manual before topping up with coolant.
	Service point.
	Circuit breaker.
	Do not run the compressor when the baffles are not in the right position.

Operating instructions

PARKING, TOWING AND LIFTING INSTRUCTIONS

Safety precautions



The operator is expected to apply all relevant Safety precautions.

Attention



Before putting the compressor in to use, check the brake system as described in section Brake shoe adjustment.

After the first 100 km travel:

Check and retighten the wheel nuts and towbar bolts to the specified torque. See section Compressor / engine specifications.

Check the brake adjustment. See section Brake shoe adjustment.



When the engine is running, the air outlet valves (ball valves) must always be put in fully opened or fully closed position.



When towing, lifting or transporting the compressor in any way, the battery switch must always be in the "OFF" position!

PARKING INSTRUCTIONS

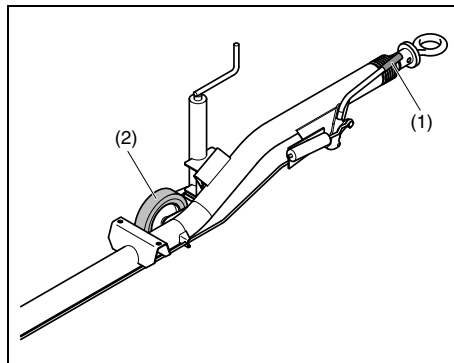

Fixed towbar with jockey wheel and brakes

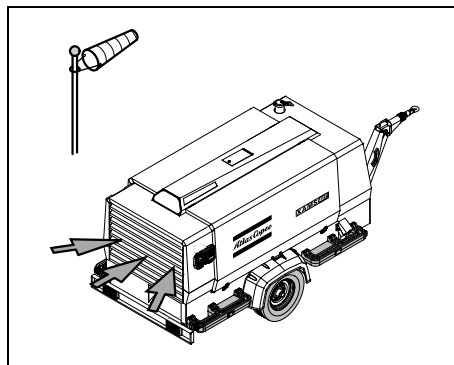

Rear-end of compressor upwind

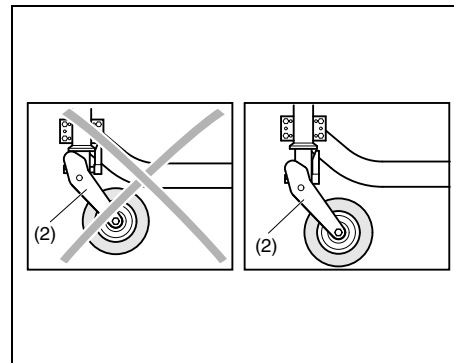

Parking position of jockey wheel (adjustable towbar)

When parking a compressor, secure the jockey wheel (2) to support the compressor in a level position. Apply parking brake by pulling parking brake handle (1) upwards. Place the compressor as level as possible; however, it can be operated temporarily in an out-of-level position not exceeding 15°. If the compressor is parked on sloping ground, immobilize the compressor by placing wheel chocks (available as option) in front of or behind the wheels. Locate the rear-end of the compressor upwind, away from contaminated wind-streams and walls. Avoid recirculation of exhaust air from the engine. This can cause overheating and engine power decrease.

TOWING INSTRUCTIONS

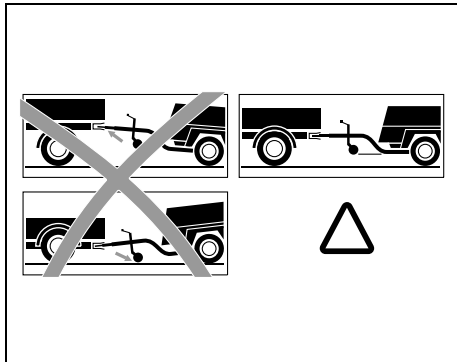

Label on towbar, towing instructions

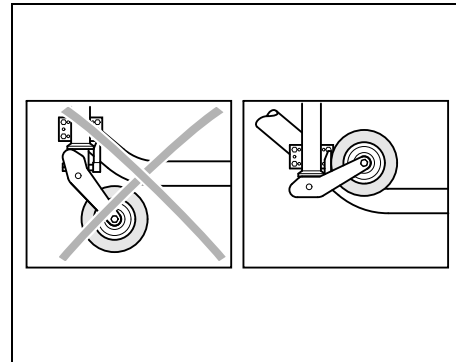
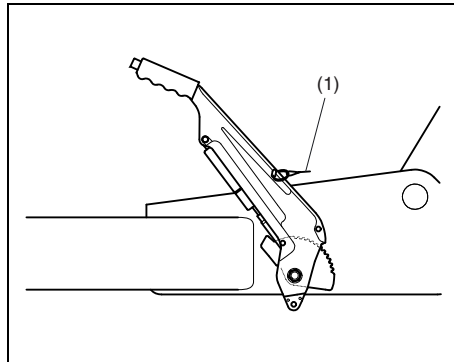

Towing position of jockey wheel



Before towing the compressor, ensure that the towing equipment of the vehicle matches the towing eye or ball connector.

The towbar should be as level as possible and the compressor and towing eye end in a level position.

Push hand brake lever completely downwards and connect breakaway cable (1) to the vehicle. Secure jockey wheel (2) in the highest possible position. The jockey wheel is prevented from turning.

Never move the compressor with air hoses connected to the air outlet valves.



Before moving the compressor, switch it off.

HEIGHT ADJUSTMENT (with adjustable towbar)

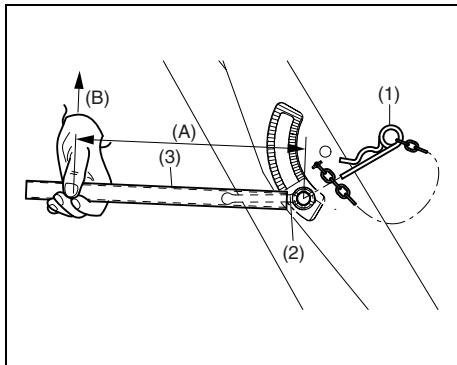

Before towing the compressor, make sure that the joints of the towbar are secured with maximum strength without damaging the towbar. Be sure that there is no clearance between the teeth of the joints.



Attention:

- Remove spring pin (1).
- Release locking nut (2) with support tools (extension tube 3).
- Adjust required height of the towbar.
- Tighten locking nut (2) by hand first.
- Secondly tighten locking nut (2) with a tightening torque corresponding to table. With an extension tube (3) ("A" corresponding to table) and handforce ("B" corresponding to table) easy tightening is possible.
- Fix locking nut (2) with spring pin (1).

- Height adjustment should be undertaken on levelled ground and in coupled condition.
- When readjusting, make sure that the front point of the towbar is horizontal to the coupling point.
- Before starting a trip, make sure that the adjustment shaft is secure, so that the stability and safety is guaranteed while driving. If necessary tighten the locking nut (2) corresponding to table.

For specific instruction see below!

Type	M [Nm/lbf.ft.]	"A" [mm/in]	"B" [N/lbf]
ZV 2000	250 - 300 / 184.5 - 221.4	600 / 23.4	420 - 500 / 94.5 - 112.5
ZV 2500	350 - 400 / 258.3 - 295.2	600 / 23.4	580 - 660 / 130.5 - 148.5

LIFTING INSTRUCTIONS

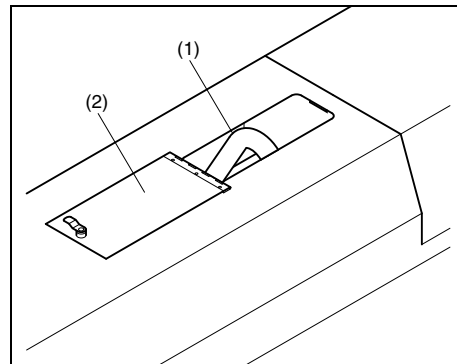

When lifting the compressor, the hoist has to be placed in such a way that the compressor, which must be placed level, will be lifted vertically. Keep lifting acceleration and retardation within safe limits.

Preferably use the lifting eye (1) after opening the small door (2).



Lifting acceleration and retardation must be kept within safe limits (max. 2xg).

Helicopter lifting is not allowed.

Lifting is not allowed when the unit is running.

STARTING / STOPPING

BEFORE STARTING

1. Before initial start-up, prepare battery for operation if not already done. See section **Recharging a battery**.
2. With the compressor standing level, check the level of the engine oil. Add oil, if necessary, to the upper mark on dipstick. Also check the engine coolant level. Consult the Engine Operation Manual for the type of coolant and type and viscosity grade of the engine oil.
3. Check the level of the compressor oil. The pointer of oil level gauge (OLG) should register in the green range. Add oil if necessary. See section **Engine oil** for the oil to be used.



Before removing oil filler plug (FP), ensure that the pressure is released by opening an air outlet valve.

4. Check that the fuel tank contains sufficient fuel. Top up, if necessary. Consult the Engine Operation Manual for the type of fuel.
5. Drain any water and sediment from the fuel filters until clean fuel flows from the drain cock. See section **Priming instructions**.
6. Empty the dust trap of each air filter (AF). See section **Cleaning the dust trap**.
7. Clogged air filter(s) will be indicated on the display of the control panel, see section **Fault codes**. If indicated, replace the filter elements.
8. Check coolant level in engine coolant top tank. Top up, if necessary. Consult the Engine Operation Manual for coolant specifications.

9. Attach the air line(s) to the closed air outlet valve(s). Connect the safety chain.



No external force may be applied to the air outlet valve(s), e.g. by pulling hoses or by connecting equipment directly to the valve(s).

Safety precautions



Do not disconnect power supply to control box in any way when the control box is switched on. This will cause memory loss.

Make sure the fuel tank is filled up.



When the compressor is put in operation for the first time and after running out of fuel or changing the fuel filter, follow the specific start procedure as described in section Priming instructions.

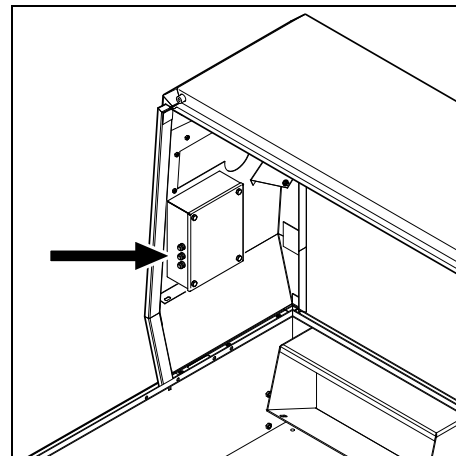

Do not switch off the circuit breaker when the control box is switched on. This will cause memory loss.

BATTERY SWITCH

The compressor is equipped with a battery switch.

When the compressor is not in use this switch must always be in the "OFF" position.



It is not allowed to use this switch as an emergency switch or for stopping the compressor. It will cause damage in the control unit when using this switch for stopping.

Always first shut off the control unit and wait until the display is dark before switching the battery switch to position "OFF".

To switch the electric system "ON", turn the handle (1) of the battery switch clockwise.

To switch the electric system "OFF", turn the handle (1) of the battery switch counterclockwise.



Please be aware that when the electric system is switched "OFF" the batteries are still under tension.

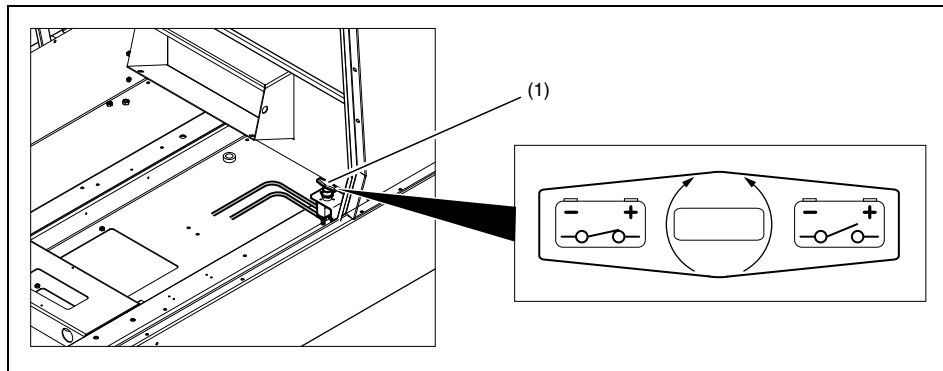

CONTROL PANEL

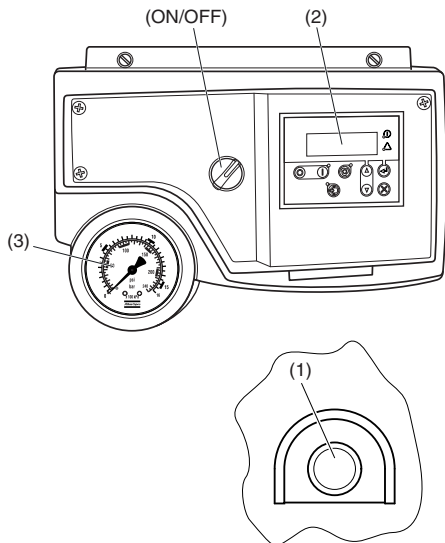

Control panel

Reference	Name
1	Emergency stop
2	Xc2002™ module
3	Pressure gauge
ON/OFF	Power ON/OFF switch

XC2002™ MODULE

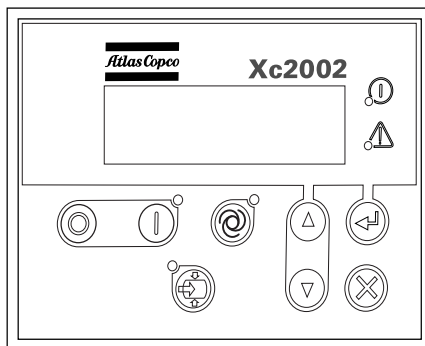

The Xc2002™ module is located inside the control panel. This module will carry out all necessary tasks to control and protect the compressors, regardless of the use of the compressor.

This means that the Xc2002™ module can be used for several applications.

Pushbutton and LED functions

Following pushbuttons are used on the Xc2002™

	ENTER: Used to select and confirm changed settings in the Parameters list.
	BACK: Is used to leave the Alarm pop-up window, to leave the Parameter list and to leave menu's without change
	UP: Is used to scroll through the display information and to adjust parameter values upwards.
	DOWN: Is used to scroll through the display information and to adjust parameter values downwards.
	START: Is used to start the unit in Manual Mode.
	LOAD: Is used to load the compressor
	AUTO-LOAD: Is used to activate the auto-load function of the compressor
	STOP: Is used to stop the unit in Manual or Automatic Load Mode (without cool down). When the unit is stopped with the stop button in Automatic Load Mode, it will automatically go to Manual Mode.

Following LED's are used on the Xc2002™

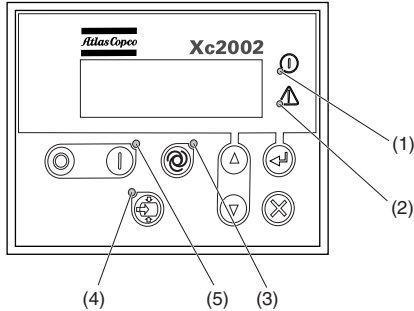

Reference	Name
1	Power: Power OK indicator.
2	Alarm: Flashing: Active, non-acknowledged alarm(s) present. Steady: Active, acknowledged alarm(s) present.
3	Auto/Remote: Indicates if unit is in Auto or Remote mode.
4	Load: Indicates if the compressor is loaded.
5	Run: Indicates if running feedback is present.

XC2002™ MENU OVERVIEW

At Xc2002™, the LCD will show the following information through the display views:

1. in **Normal** condition (scroll through the information using **UP** and **DOWN**):

- Controller type & version

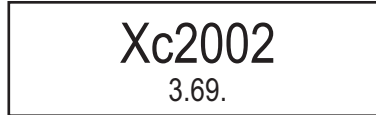

This view shows the controller type and the software version number.

- Fuel level

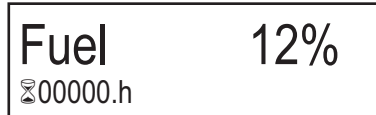

This view shows the fuel level (in %) and the running hours.

- Oil pressure



This view shows the engine oil pressure and the running hours.

See also "Parameter list" on page 34 for selection between metric (bar) or imperial (psi) units.

- Coolant temperature



This view shows the engine coolant temperature and the running hours.

See also "Parameter list" on page 34 for selection between metric (°C) or imperial (°F) units.

- Engine RPM

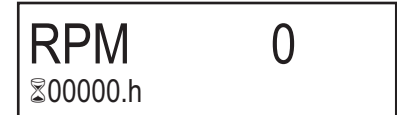

This view shows the engine running speed (in RPM) and the running hours.

- Battery voltage



This view shows the battery voltage and the running hours.

- Service Timer 1 & Service Timer 2



This view shows both Service Timers. The Service Timer indication is shown when service time has run out.

The Service Timer indications counts upwards and gives an alarm when the set value is reached.

- LOG list



This view shows the alarm memory and gives access to it.

- Xc2002 Event LOG #01

- Xc2002 Event LOG #02



This view shows the event log and the service timer.

The event log will be stored upon shutdown or service timer acknowledgement.

Emergency stop log will be stored separately

- Alarm list

- contains a list of active alarms



This view shows the number of active alarms and gives access to them.

An overview is given in "Alarm Display (pop up window)" on page 37.

- Parameter list



This view shows a number of Parameter settings and gives access to them.

The Parameter Menu's are pre-programmed!

A password will be requested for when an attempt to change a setting is about to be done (user password = 2003)

Menu's shown on the Parameter list LCD:

- Language



This view shows the language in use and with scroll **UP** or **DOWN** a list of available languages and gives access to them.

Icons is the default factory set language, however 6 other languages can be selected: English, French, Spanish, German, Italian and Cyrillic (Russian). All information in the Parameter List display is always in English.

- Unit



This menu can be accessed to select units of measure in either metric (°C, bar) or imperial (°F, psi) units.

See also "Parameter list" on page 34 for selection between metric (°C) or imperial (°F) units.

- Auto NoLoad

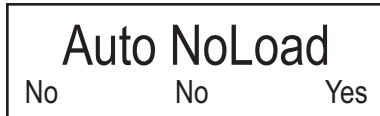

When "no" selected the unit will remain in unload when not loaded for a certain time.

When "yes" selected the unit will switch to noload when running unload for a certain time.

- ST1 Reset

- ST2 Reset

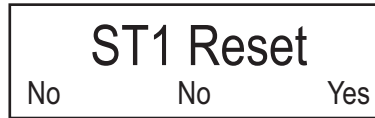

These views are the Service Timer resets. When "Yes" is selected a customer level password will be requested prior to approving the Service Timer Reset.

When a service timer alarm occurs and is acknowledged, the service timer will be reset automatically.

- Unit Type



This view shows the model type of the compressor.

1 = default unit type

It is possible to scroll between configuration menu's by using the pushbuttons UP and DOWN.

Pushing the ENTER button activates the configuration menu which is shown on the display.

- Extra views display



This view shows the extra views available in the controller.

- Fuel pressure



This view shows the fuel pressure and the running hours.

See also "Parameter list" on page 34 for selection between metric (bar) or imperial (psi) units.

- Fuel consumption



This view shows the engine fuel consumption and the running hours.

See also "Parameter list" on page 34 for selection between metric (L/h) or imperial (Gal/h) units.

- Air Inlet temperature

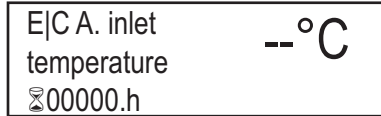

This view shows the air temperature at inlet and the running hours.

See also "Parameter list" on page 34 for selection between metric (°C) or imperial (°F) units.

- Regulating pressure

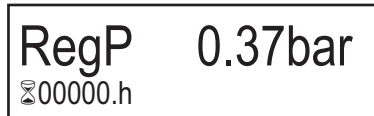

This view shows the regulating pressure and the running hours.

See also "Parameter list" on page 34 for selection between metric (bar) or imperial (psi) units.

- Vessel pressure



This view shows the vessel pressure and the running hours.

See also "Parameter list" on page 34 for selection between metric (bar) or imperial (psi) units

- Compressor element temperature



This view shows the compressor element temperature and the running hours.

See also "Parameter list" on page 34 for selection between metric (°C) or imperial (°F) units

2. in **Alarm** condition (scroll through the information using **UP** and **DOWN**):

- a list of all active Alarms

It is possible to scroll through the views, using the **UP** and **DOWN** buttons. The scrolling is continuous.

If a special status comes up, the Status Display is shown. If an Alarm comes up, the Alarm Display is shown.

XC2002™ MENU DESCRIPTION

Status Display (pop-up window)

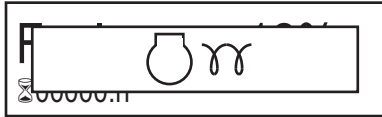

In case special statuses are entered, a pop-up window will automatically be entered for as long as the status is active.

The background screen is not updated when the status pop-up window is active.

These special statuses are:

• PREHEAT	
• START OF	
• COOLDOWN	
• EXT. STOP TIME	
• DIAGNOSTICS	
• LOAD / NO LOAD	

If a special status has elapsed, the active view will be entered again automatically.

If an Alarm comes up, the Alarm Display is shown.

Alarm Display (pop-up window)

In case an Alarm occurs, a pop-up window will automatically be displayed for as long as the alarm is active, no matter which view is active. The flashing red alarm LED will light up. The alarm icons will be shown together with an acknowledgement check-box. Push the **ENTER** button to acknowledge the alarm. When the alarm has been acknowledged, a V-marking will appear in the check-box and the red alarm LED will light up continuously.









An alarm should always be acknowledged before solving the problem that causes the alarm.

An Alarm Display can always be left by pushing the **BACK** button.

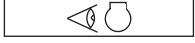
If more than one alarm occurs, it is possible to scroll through the alarm messages with the UP and DOWN pushbuttons. The most recent alarm will be placed on the bottom of the list (meaning the older alarm stays at the display when a new alarm comes up).

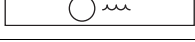
List of possible alarms:

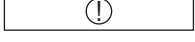
1. LOW OIL PRESSURE	
2. HIGH COOLANT TEMPERATURE	
3. CHARGING ALTERNATOR	
4. XDEC	
5. LOW FUEL LEVEL	
6. LOW COOLANT LEVEL	
11. SERVICE TIMER 1	Y1
12. SERVICE TIMER 2	Y2
13. ELEMENT TEMPERATURE	
14. ALARM	

If a shutdown comes up, the Shutdown Display is shown.

LOG list

The unit will keep an event log of the latest 15 events.

Events are:

- shutdowns
- warnings
- Service Timer 1/2 reset
- Unit type changes

Together with each event, the running hours at the time of the event will be stored.

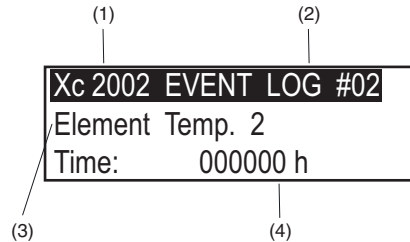

Reference	Name
1	Controller Type
2	Event Number
3	Event
4	Time of event

Fail Classes

All activated alarms of the Xc2002™ have their own predefined fail class.

All alarms are enabled according to one of these three statuses:

- disabled alarm, no supervision of alarm (OFF)
- enabled alarm, supervision of alarm all the time (ON)
- running alarm, only supervision when the machine is running (RUN)

DURING OPERATION

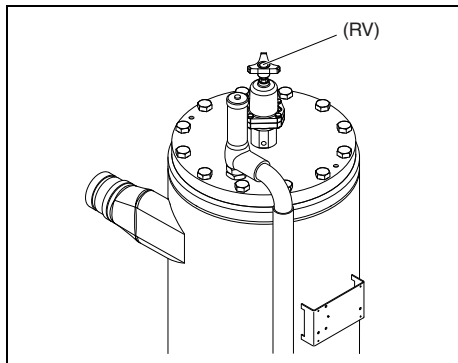

The doors must be closed during operation and may be opened for short periods only.

Regularly carry out following checks:

1. That the regulating valve (RV) is correctly adjusted, i.e. starts decreasing the engine speed when reaching the preset working pressure in the receiver.
2. Check the air outlet temperature of the compressor element.
3. Check the engine oil pressure, the coolant temperature and all lamps for normal readings.

4. Avoid the engine running out of fuel. Nevertheless, if this happens, fill the fuel tank and prime the fuel system to speed up starting (see section **Priming instructions**).



When the engine is running the air outlet valves (ball valves) must always be put in fully opened or fully closed position.

OPERATIONS OVERVIEW

It is possible to control the compressor locally with the Control Box, remotely with the remote switch inputs located on the back of the Control Box, or with software running on a PC with a CAN interface (PC Control Mode).

The way one ends up in each status can differ from how the Control Box is controlled, but the function of each status stays the same.

When reading this document, mind the difference between a status and a procedure. A status is a state in the Control Box's operation. A procedure is an action executed by the Control Box.

Example: The Stopping procedure is executed in the Stopping status, the Start Failure status and the Shutdown status.

POWER ON / OFF

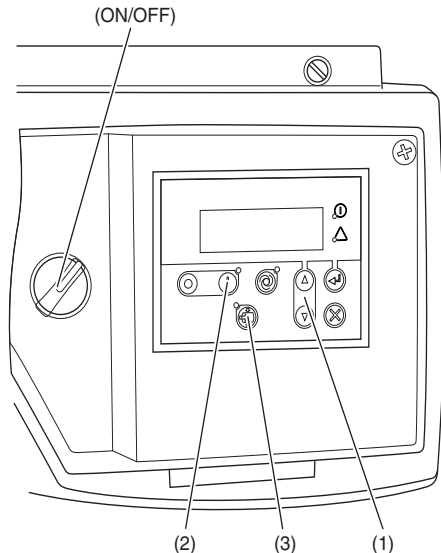

Switch on the battery switch

Switch the machine on by switching the "ON/OFF" switch to the position "ON".

The display will show:

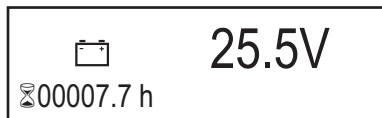

With the scroll buttons (1) you can scroll through the display information

STARTING

Press the button "I" (2)

- When the ambient temperature is below 10 °C (50 °F) the display will show:

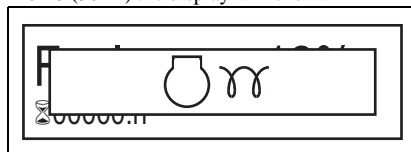

Indicating that preheating is necessary before the engine will start.

- When the ambient temperature is over 10 °C (50 °F) the display will show:

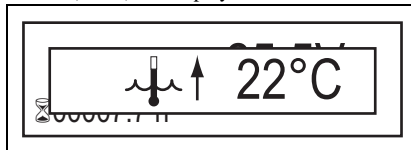

WARMING UP

When the engine started the warming up is started. The compressor can be loaded after the compressor has reached a temperature of 40 °C (104 °F), or after a warming up period of 5 minutes.

After warming up the LED at the load button will blink at low frequency, the engine will run idle.

When pressing the load button (3) the display will show:

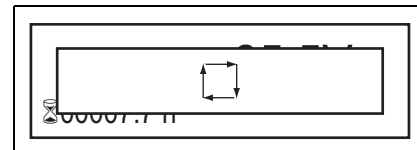

and the compressor will be loaded after warming up

LOADING

By pressing the load button (3) the compressor will be loaded, the pressure will rise until it reaches the setting. The LED at the load button will blink at high frequency and will be lit continuously when the set pressure is reached.

The display will show:

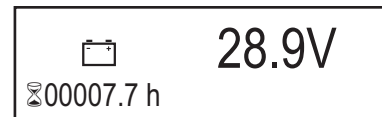

With the scroll buttons (1) you can scroll through the display information.

STOPPING

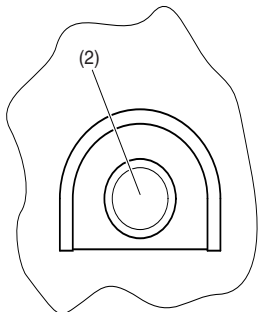
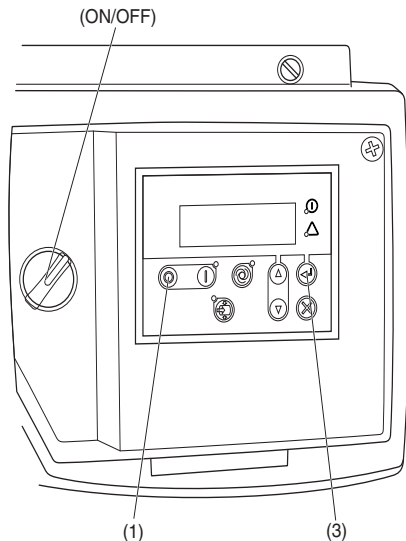

To turn off the compressor first press the button "0" (1). The engine will run some time at minimum speed to cool down and will stop finally.

The remaining time is shown in the display:

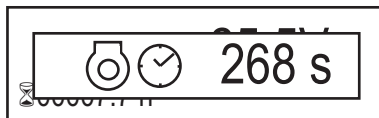

Meanwhile the air receiver is depressurized.

Switch the "ON/OFF" switch to the position "OFF".

Wait until the display is dark.

Switch the battery switch in the "OFF" position.

EMERGENCY STOP

The emergency stop button (2) is only to be used in emergency situations; not for stopping procedures.

When an emergency stop button is pressed, power to all outputs is terminated, by the emergency stop itself (hardware) as well as by the software.

The display will show:

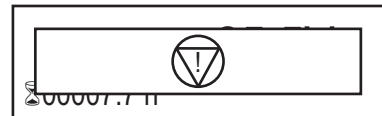

To proceed operation the emergency stop button has to be unlocked and the alarm has to be acknowledged by pressing the enter button (3)

The display will show:

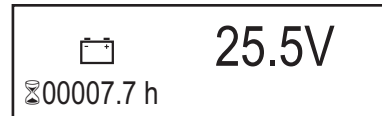

FAULT CODES

There are several parameters that are continuously watched.

The message displayed can be a warning, a shut down or a start failure.

When one of these parameters exceeds its specified limit the compressor will react depending the present status of the control box.

Display text	Warning	Shutdown	Wait to start
Engine Fault Codes (Canbus SAE J1939):			
Engine Sensor Failure	X	X	
Fuel Temperature High	X		
Fuel Pressure Low	X		
Coolant Temperature High	X	X	
Injector Failure	X		
Oil Pressure low	X	X	
Air Inlet Temperature High	X		
Turbo Boost Pressure High	X		
Xc2002 Fault Codes:			
Sensor Failure (Fuel Level, Vessel Pressure, Regulating Pressure, Element Temperature)		X	
Can SAE J1939 Communication Failure		X	
Overspeed		X	
Fuel Level Low	X	X	
Vessel pressure High		X	
Element Temperature High	X	X	
Coolant Level Low		X	
Vessel Pressure Start Prevention			X
Battery Voltage Low	X		
Battery Charge Failure	X		
Check Airfilters	X		
Start Failure		X	
Stop Failure		X	
Service Timer 1	X		
Service Timer 2	X		
Emergency Stop		X	

Maintenance

LIABILITY

The manufacturer does not accept any liability for any damage arising from the use of non-original parts and for modifications, additions or conversions made without the manufacturer's approval in writing.

SERVICE PAKS

A Service Pak is a collection of parts to be used for a specific maintenance task, e.g. after 50, after 500 and after 1000 running hours.

It guarantees that all necessary parts are replaced at the same time keeping down time to a minimum.

The order number of the Service Paks are listed in the Atlas Copco Parts List (ASL).

Use of service paks

Service Paks include all genuine parts needed for normal maintenance of both compressor and engine.

Service Paks minimize downtime and keep your maintenance budget low.

Order Service Paks at your local Atlas Copco dealer.

SERVICE KITS

A service kit is a collection of parts to fit a specific repair or rebuilding task.

It guarantees that all necessary parts are replaced at the same time which improves the uptime of the unit.

The order numbers of the Service Kits are listed in the Atlas Copco Parts List (ASL).



Contact Atlas Copco.

STORAGE

Run the compressor regularly, e.g. twice a week, until warm.

Load and unload the compressor a few times to operate the unloading and regulating components. Close the air outlet valves after stopping.



If the compressor is going to be stored without running from time to time, protective measures must be taken.

PREVENTIVE MAINTENANCE SCHEDULE FOR THE COMPRESSOR

The schedule contains a summary of the maintenance instructions. Read the respective section before taking maintenance measures.

When servicing, replace all disengaged packings, e.g. gaskets, O-rings, washers.

For engine maintenance refer to Engine Operation Manual.

The maintenance schedule has to be seen as a guideline for compressors operating in a dusty environment typical to compressor applications. Maintenance schedule can be adapted depending on application, environment and quality of maintenance.

Maintenance schedule	Daily	50 hours after initial start-up	Every 6 months or 500 hours	Yearly or every 1000 hours
XAMS 407 Cd - XAMS 850 CD7, XATS 377 Cd - XATS 800 CD7, XAHS 347 Cd - XAHS 710 CD7, XAVS 307 Cd - XAVS 650 CD7		supplied with unit	2912 4482 05	2912 4483 06
Engine oil level	Check			
Condensate (11)	Drain			
Compressor oil level	Check			
Coolant level	Check			
Air filter vacuator valves	Empty			
Fuel filter water drain	Drain			
ABS vessel drain	Drain			
Electrolyte level and terminals of battery		Check	Check	Check
Tyre pressure		Check	Check	Check
Leaks in air-, oil- or fuel system (12)		Check	Check	Check
Oil cooler			Clean	Clean
Radiator			Clean	Clean

(to be continued on page 45)

Maintenance schedule <i>(continuation of page 44)</i>	Daily	50 hours after initial start-up	Every 6 months or 500 hours	Yearly or every 1000 hours
Intercooler			Clean	Clean
Torque of wheel nuts		Check	Check	Check
Brake system (if installed)		Check/Adjust	Check/Adjust	Check/Adjust
Safety valve (10)				Test
Door hinges			Grease	Grease
Towing eye shaft or ball coupling and shaft			Grease	Grease
Bleed-off valve unloader				Replace
Oil stop valve				Clean
Rubber flexibles (12)				Check
Shut-down switches				Check
Pressure drop over oil separator element (2)				Replace
Fan V-belts (3)		Adjust	Adjust	Adjust
Bleed-off valve unloader				Replace
Fuel tank			Clean	Clean
Compressor oil (1) (8)				Change
Compressor oil filter (6)		Replace		Replace
Coolant (9) (5)				Analyse
Air filter element (1)				Replace
Engine oil (3) (4)			Change	Change
Engine oil filter (3)			Replace	Replace
Primary fuel filter (AC filter) (7)			Replace	Replace
Fuel prefilter (3) (7)			Replace	Replace

(to be continued on page 45)

Maintenance schedule <i>(continuation of page 45)</i>	Daily	50 hours after initial start-up	Every 6 months or 500 hours	Yearly or every 1000 hours
Fuel filter (3) (7)			Replace	Replace
Engine inlet and outlet valves (3)			Adjust	Adjust
Filter element from regulating valve				Replace
Flow restrictor in oil scavenge line				Clean
Inspection by Atlas Copco Service Technician				Inspection

Notes



1. More frequently when operating in a dusty environment.
2. Replace the element when the pressure drop exceeds 0.8 bar (11.6 psi).
3. Refer to the engine operation manual.
4. 200 / 500 hours is only valid when using PAROIL 15W40.
5. Check coolant every year. Change coolant every 5 years.
6. Use Atlas Copco oil filters, with by-pass valve, as specified in the parts list.
7. Replace the fuel filters regularly. Gummed or clogged filters mean fuel starvation and reduced engine performance. The quality of the fuel determines the frequency of renewal.
8. See section **Oil specifications**.
9. The following part numbers can be ordered from Atlas Copco to check on inhibitors and freezing point:
 - 2913 0028 00 refractometer
 - 2913 0029 00 pH meter.
10. See section **Safety valve**.
11. See section **Before starting**.
12. Replace all rubber flexibles each 6 years, according to DIN 20066.



Keep the bolts of the housing, the lifting beam, tow bar and axles securely tightened. For torque values see section Technical specifications.

OIL SPECIFICATIONS



It is strongly recommended to use Atlas Copco branded lubrication oils for both compressor and engine.



Only use mineral based compressor oil PAROIL M in XAMS 407 Cd - XAMS 850 CD7, XATS 377 Cd - XATS 800 CD7, XAHS 347 Cd - XAHS 710 CD7 and XAVS 307 Cd - XAVS 650 CD7.

High-quality, mineral, hydraulic or synthesized hydrocarbon oil with rust and oxidation inhibitors, anti-foam and anti-wear properties is recommended. The viscosity grade should correspond to the ambient temperature and ISO 3448, as follows:



Never mix synthetic with mineral oil.

Remark:

When changing from mineral to synthetic oil (or the other way around), you will need to do an extra rinse:

After doing the complete change procedure to synthetic oil, run the unit for a few minutes to allow good and complete circulation of the synthetic oil.

Then drain the synthetic oil again and fill again with new synthetic oil. To set correct oil levels, proceed as in normal instruction.

Type of lubricant	Compressor	Engine
between 30°C (86°F) and 40°C (104°F)	PAROIL S	PAROIL 15W40
between -5°C (23°F) and 30°C (86°F)	PAROIL M PAROIL S	PAROIL 15W40
between -20°C (-4°F) and -5°C (23°F)	PAROIL S	PAROIL 5W30

COMPRESSOR OIL

Synthetic compressor oil PAROIL S

	Liter	US gal	Order number
can	5	1.3	1615 5950 01
can	20	5.3	1615 5951 01
barrel	210	55.2	1615 5952 01
container	1000	265	1604 7422 00

Mineral compressor oil PAROIL M

	Liter	US gal	Order number
can	5	1.3	1615 5947 00
can	20	5.3	1615 5948 00
barrel	210	55.2	1615 5949 00

Synthetic compressor oil PAROIL S68

	Liter	US gal	Order number
can	20	5.3	1604 7136 00
barrel	210	55.2	1604 7137 00

ENGINE OIL

PAROIL from Atlas Copco is the ONLY oil tested and approved for use in all engines built into Atlas Copco compressors and generators.

Extensive laboratory and field endurance tests on Atlas Copco equipment have proven PAROIL to match all lubrication demands in varied conditions. It meets stringent quality control specifications to ensure your equipment will run smoothly and reliably.

The quality lubricant additives in PAROIL allow for extended oil change intervals without any loss in performance or longevity.

PAROIL provides wear protection under extreme conditions. Powerful oxidation resistance, high chemical stability and rust- inhibiting additives help reduce corrosion, even within engines left idle for extended periods.

PAROIL contains high quality anti-oxidants to control deposits, sludge and contaminants that tend to build up under very high temperatures. PAROIL's detergent additives keep sludge forming particles in a fine suspension instead of allowing them to clog your filter and accumulate in the valve/rocker cover area.

PAROIL releases excess heat efficiently, whilst maintaining excellent bore-polish protection to limit oil consumption.

PAROIL has an excellent Total Base Number (TBN) retention and more alkalinity to control acid formation.

PAROIL prevents soot build-up

PAROIL is optimized for the latest low emission EURO -3 & -2, EPA TIER II & III engines running on low sulphur diesel for lower oil and fuel consumption.

PAROIL 5W30 is a synthetic ultra high performance diesel engine oil with a high viscosity- index. Atlas Copco PAROIL 5W30 is designed to provide excellent lubrication from start-up in temperatures as low as -25° C (-13° F).

PAROIL 15W40 is a mineral based high performance diesel engine oil with a high viscosity- index. Atlas Copco PAROIL 15W40 is designed to provide a high level of performance and protection in 'standard' ambient conditions as from -15° C (5° F).

Synthetic engine oil PAROIL 5W30

	Liter	US gal	Order number
can	5	1.3	1604 6060 00
can	20	5.3	1604 6059 00

Mineral engine oil PAROIL 15W40

	Liter	US gal	Order number
can	5	1.3	1615 5953 00
can	20	5.3	1615 5954 00
barrel	210	55.2	1615 5955 00

OIL LEVEL CHECK

CHECK ENGINE OIL LEVEL

Also consult the Engine Operation Manual for the oil specifications, viscosity recommendations and oil change intervals.

For intervals, see **Preventive maintenance schedule for the compressor.**

Check engine oil level according to the instructions in the Engine Operation Manual and if necessary top up with oil.

CHECK COMPRESSOR OIL LEVEL

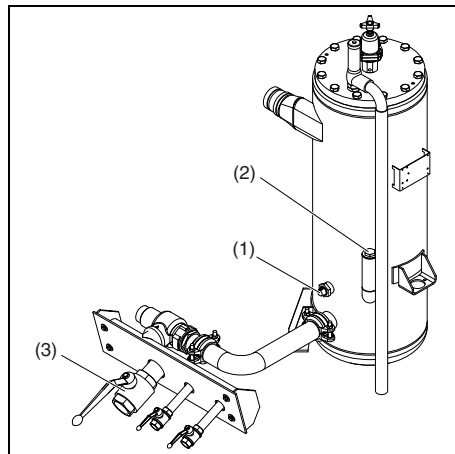

With the unit standing horizontal, check the level of the compressor oil. The pointer of the oil level gauge (1) must register in the upper extremity of the green range. Add oil if necessary.



Before removing the oil filler plug (2), ensure that the pressure is released by opening an air outlet valve (3).

OIL AND OIL FILTER CHANGE

ENGINE OIL AND OIL FILTER CHANGE

See section **Preventive maintenance schedule for the compressor.**

COMPRESSOR OIL AND OIL FILTER CHANGE

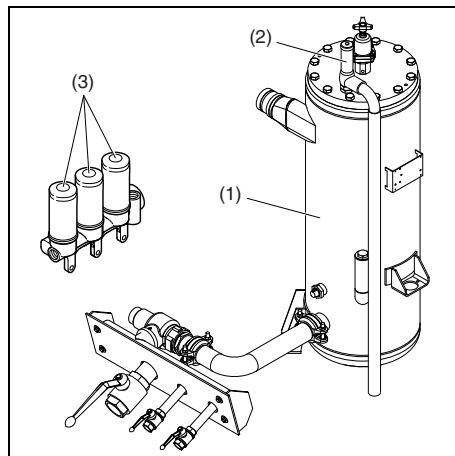

The quality and the temperature of the oil determine the oil change interval.

The prescribed interval is based on normal operating conditions and an oil temperature of up to 100 °C (212 °F) (see section **Preventive maintenance schedule for the compressor**).

When operating in high ambient temperatures, in very dusty or high humidity conditions, it is recommended to change the oil more frequently.



In this case, contact Atlas Copco.

1. Run the compressor until warm. Close the outlet valve(s) (1) and stop the compressor. Wait until the pressure is released through the automatic blow-down valve. Unscrew the oil filler plug (2) one turn. This uncovers a vent hole, which permits any pressure in the system to escape.
2. Drain the compressor oil by removing all relevant drain plugs. Drain plugs are located at the air receiver (DPar), compressor element (DPcv, DPosv) and compressor oil cooler (DPoc). Catch the oil in a drain pan. Screw out the filler plug (2) to speed up draining. After draining, place and tighten the drain plugs.
3. Remove the oil filters (3), e.g. by means of a special tool. Catch the oil in a drain pan.
4. Clean the filter seat on the manifold, taking care that no dirt drops into the system. Oil the gasket of the new filter element. Screw it into place until the gasket contacts its seat, then tighten one half turn only.
5. Fill the air receiver until the pointer of the oil level gauge is in the upper part of the green area. Be sure that no dirt gets into the system. Reinstall and tighten the filler plug (2).
6. Start the compressor and let it run unloaded for a few minutes.
7. Stop the compressor, wait a few minutes and top up with oil until the pointer of the oil level gauge is in the upper part of the green area.



Never add more oil. Overfilling results in oil consumption.

TOPPING UP THE COMPRESSOR OIL

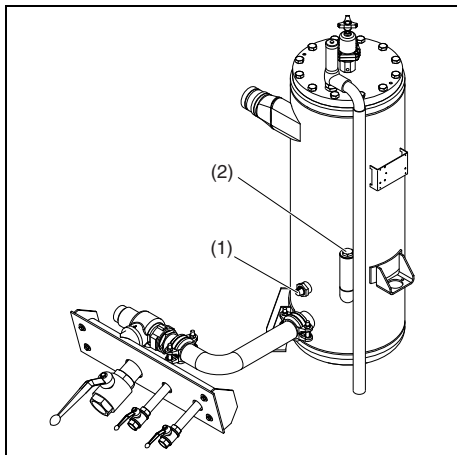

1. Stop the compressor and be sure that all pressure has been released by opening the filler plug (2) one turn.
2. Wait a few minutes until the oil level is constant (oil level gauge (1)).
3. Remove the oil filler plug (2) and top up with oil until the pointer of the oil level gauge (1) is in the upper part of the green area.
4. Reinstall and tighten the filler plug (2).

COOLANT SPECIFICATIONS



It is strongly recommended to use Atlas Copco branded coolant.

The use of the correct coolant is important for good heat transfer and protection of liquid-cooled engines. Coolants used in these engines must be mixtures of good quality water (distilled or de-ionised), special coolant additives and if necessary freeze protection. Coolant that is not to manufacturer's specification will result in mechanical damage of the engine.

The freezing point of the coolant must be lower than the freezing point that can occur in the area. The difference must be at least 5°C (9°F). If the coolant freezes, it may crack the cylinder block, radiator or coolant pump.

Consult the engine's operation manual and follow the manufacturer's directions.



Never mix different coolants and mix the coolant components outside the cooling system.

PARCOOL EG

PARCOOL EG is the only coolant that has been tested and approved by all engine manufacturers currently in use in Atlas Copco compressors and generators.

Atlas Copco's PARCOOL EG extended life coolant is the new range of organic coolants purpose designed to meet the needs of modern engines. PARCOOL EG can help prevent leaks caused by corrosion. PARCOOL EG is also fully compatible with all sealants and gasket types developed to join different materials used within an engine.

PARCOOL EG is a ready to use Ethylene Glycol based coolant, premixed in an optimum 50/50 dilution ratio, for antifreeze protection guaranteed to -40°C (-40°F).

Because PARCOOL EG inhibits corrosion, deposit formation is minimized. This effectively eliminates the problem of restricted flow through the engine coolant ducts and the radiator, minimizing the risk for engine overheating and possible failure.

It reduces water pump seal wear and has excellent stability when subjected to sustained high operating temperatures.

PARCOOL EG is free of nitride and amines to protect your health and the environment. Longer service life reduces the amount of coolant produced and needing disposal to minimise environmental impact.

PARCOOL EG

	Liter	US gal	Order number
can	5	1.3	1604 5308 00
can	20	5.3	1604 5307 01
barrel	210	55.2	1604 5306 00

To ensure protection against corrosion, cavitation and formation of deposits, the concentration of the additives in the coolant must be kept between certain limits, as stated by the manufacturer's guidelines. Topping up the coolant with water only, changes the concentration and is therefore not allowed.

Liquid-cooled engines are factory-filled with this type of coolant mixture.

PARCOOL EG Concentrate

	Liter	US gal	Order number
can	5	1.3	1604 8159 00

HANDLING PARCOOL EG

PARCOOL EG should be stored at ambient temperatures, while periods of exposure to temperatures above 35°C (95°F) should be minimized. PARCOOL EG can be stored for a minimum of 5 years in unopened containers without any effect on the product quality of performance.

PARCOOL EG is compatible with most other coolants based on ethylene glycol, but you only get the benefits of 5 years protection when its used on its own. Exclusive use of PARCOOL EG is recommended for optimum corrosion protection and sludge control.

For simple density-measuring of Ethylene Glycol and Propylene Glycol in general the standard available 'density' measuring devices are used to measure the concentration of EG. In case a device is used to measure EG, no PG can be measured afterwards as a result of the difference in the density. More specific measurements can be done by the use of a refractometer. This device can measure both EG and PG. A mix of both products will be show unreliable results!

Mixed EG coolants with identical glycol type can be measured by use of a refractometer as well as the 'density' system. The mixed coolants will be considered as one product.

The use of distilled water is recommended. If you have exceptionally soft water it would be acceptable, as well. Basically, the engine metals are going to corrode to some extent no matter what water you use, and hard water will encourage the resulting metal salts to precipitate.

PARCOOL EG comes as a pre-mixed coolant to safeguard the quality of the complete product.

It is recommended that topping up of the cooling system is always done with PARCOOL EG.

COOLANT CHECK



Never remove the cooling system filler cap while coolant is hot.

The system may be under pressure. Remove the cap slowly and only when coolant is at ambient temperature. A sudden release of pressure from a heated cooling system can result in personal injury from the splash of hot coolant.

In order to guarantee the lifetime and quality of the product, thus to optimise engine protection, regular coolant-condition-analysis is advisable.

The quality of the product can be determined by three parameters:

Visual check

- Verify the outlook of the coolant regarding colour and make sure that no loose particles are floating around.

pH measurement

- Check the pH value of the coolant using a pH-measuring device.
- The pH-meter can be ordered from Atlas Copco with part number 2913 0029 00.
- Typical value for EG = 8.6.
- If the pH-level is below 7 or above 9.5, the coolant should be replaced.

Glycol concentration measurement

- To optimise the unique engine protection features of the PARCOOL EG the concentration of the Glycol in the water should be always above 33 vol.%.
• Mixtures with more than 68 vol.% mix ratio in water are not recommended, as this will lead to high engine operating temperatures.
- A refractometer can be ordered from Atlas Copco with part number 2913 0028 00.



In case of a mix of different coolant products this type of measurement might provide incorrect values.

TOPPING UP/REPLACING COOLANT

- Verify if the engine cooling system is in a good condition (no leaks, clean,...).
- Check the condition of the coolant.
- If the condition of the coolant is outside the limits, the complete coolant should be replaced (see section **Replacing the coolant**).
- Always top-up with PARCOOL EG Concentrate / PARCOOL EG.
- Topping up the coolant with water only, changes the concentration of additives and is therefore not allowed.

TOPPING UP WITHOUT DRAINING FROM THE COOLING SYSTEM

The quantity of PARCOOL EG Concentrate to be topped up can be estimated with the following formula and/or graph:

Corrections concentrate in measured system towards 50% volume by using PARCOOL EG Concentrate

PN: 1604 8159 00

Example:

Total volume coolant = 14 Liter

Measured concentration = 33 Vol. %

$$50 - \frac{33}{33} = 17 * \frac{14}{50} = 4,8 \text{ Liter PARCOOL EG Concentrate}$$

Top-up volume PARCOOL EG Concentrate without drainage

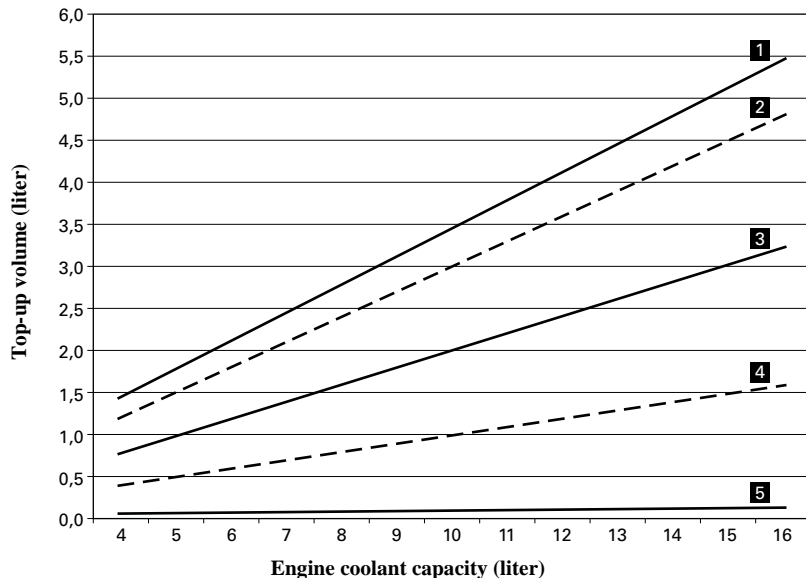

In case of expansion tank at low level, this quantity is to be filled without draining from the cooling system.

- 1 Refractometer indication -20° C (-4° F) (33%)
- 2 Refractometer indication -22° C (-7.6° F)
- 3 Refractometer indication -25° C (-13° F)
- 4 Refractometer indication -30° C (-22° F)
- 5 Refractometer indication -36° C (-32.8° F)

TOPPING UP AFTER LIMITED QUANTITY DRAINING FROM THE COOLING SYSTEM

The quantity of PARCOOL EG Concentrate to be topped up after draining a calculated volume from the cooling system, can be estimated with the following formula and/or graph:

Corrections concentrate in measured system towards 50% volume by using PARCOOL EG Concentrate

PN: 1604 8159 00

Example:

Total volume coolant = 80 Liter

Measured concentration = 33 Vol. %

50- 33 = 17 * 80 / 67 = 20 Liter PARCOOL EG Concentrate

100- 33 = 67

Top-up volume PARCOOL EG Concentrate with drainage

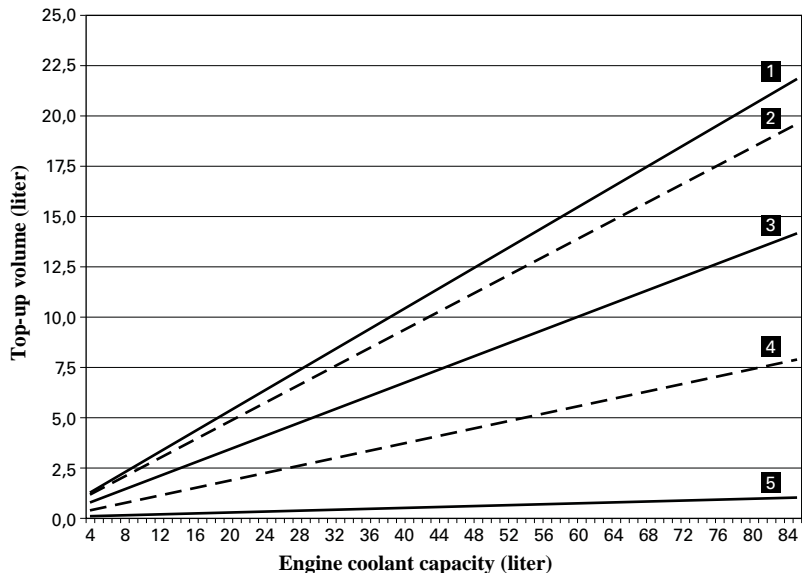

In case of expansion tank at normal level, this quantity is to be drained from the cooling system.

- 1 Refractometer indication -20° C (-4° F) (33%)
- 2 Refractometer indication -22° C (-7.6° F)
- 3 Refractometer indication -25° C (-13° F)
- 4 Refractometer indication -30° C (-22° F)
- 5 Refractometer indication -36° C (-32.8° F)

REPLACING THE COOLANT

Drain

- Completely drain the entire cooling system.
- Used coolant must be disposed or recycled in accordance with laws and local regulations.

Flush

- Flush twice with clean water. Used coolant must be disposed or recycled in accordance with laws and local regulations.
- It is recommended to let the unit drain overnight.
- It should be clearly understood that the risk for contamination is reduced in case of proper cleaning.
- In case a certain content of 'other' coolant remains in the system, the coolant with the lowest properties influences the quality of the 'mixed' coolant.

Fill

- To assure proper operation and the release of trapped air, run the engine until normal engine operation temperature is reached. Turn off the engine and allow to cool.
- From the Atlas Copco Instruction book, determine the amount of PARCOOL EG required.
- Mix concentrate and water before filling.
- Fill with a maximum rate of 10 l/min (0.35 cu.ft/min).
- Recheck coolant level and add coolant mixture if necessary.



Caution: do not top off when the engine is hot.

CLEANING COOLERS

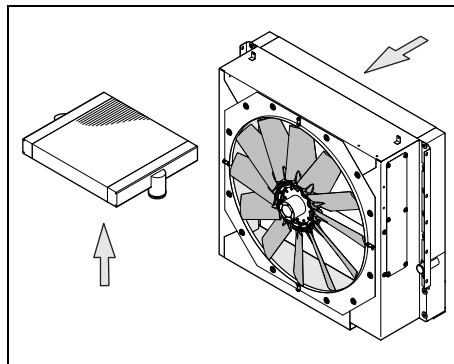

Keep the compressor oil cooler and engine liquid cooler clean to maintain the cooling efficiency.



Remove any dirt from the coolers with a fibre brush. Never use a wire brush or metal objects.

Clean by air jet in the direction of the arrow.

Steam cleaning in combination with a cleansing agent may be applied (do not use jet at max. power).



To avoid damaging the coolers, angle between jet and coolers should be approx. 90 °.

Close the service door(s).



Protect the electrical and controlling equipment, air filters, etc. against penetration of moisture.

Never leave spilled liquids such as fuel, oil, coolant and cleansing agents in or around the compressor.

BATTERY CARE



Before handling batteries, read the relevant safety precautions and act accordingly.

If the battery is still dry, it must be activated as described in section **Activating a dry-charged battery**.

The battery must be in operation within 2 months from being activated; if not, it needs to be recharged first.

ELECTROLYTE



Read the safety instructions carefully.

Electrolyte in batteries is a sulphuric acid solution in distilled water.

The solution must be made up before being introduced into the battery.



Always pour the sulphuric acid carefully into the distilled water; never pour the water into the acid.

ACTIVATING A DRY-CHARGED BATTERY

- Take out the battery.
- Battery and electrolyte must be at equal temperature above 10 °C (50 °F).
- Remove cover and/or plug from each cell.
- Fill each cell with electrolyte until the level reaches the mark on the battery. If there is no mark on the battery, the level must be above the plates for at least 10 mm (0.4 in) to 15 mm (0.6 in).
- Rock the battery a few times so that possible air bubbles can escape; wait 10 minutes and check the level in each cell once more; if required, add electrolyte.
- Refit plugs and/or cover.
- Place the battery in the compressor.

RECHARGING A BATTERY

Before and after charging a battery, always check the electrolyte level in each cell; if required, top up with distilled water only. When charging batteries, each cell must be open, i.e. plugs and/or cover removed.



Use a commercial automatic battery charger according to its manufacturer's instructions.

Apply with preference the slow charging method and adjust the charge current according to the following rule of thumb:

Battery capacity in Ah divided by 20 gives safe charging current in Amp.

BATTERY MAINTENANCE

- Keep the battery clean and dry.
- Keep the electrolyte level above the plates or at the indicated level. Level above plates at least 10 mm (0.4 in) to 15 mm (0.6 in). Top up with distilled water only.
- Keep the terminals and clamps tight, clean, and lightly covered with petroleum jelly.

COMPRESSOR ELEMENT OVERHAUL

When a compressor element is due for overhaul, it needs to be done by Atlas Copco. This guarantees the use of genuine parts and correct tools with care and precision.

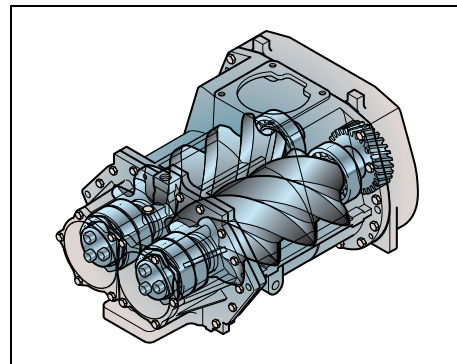

Adjustments and servicing procedures

ADJUSTMENT OF THE CONTINUOUS REGULATING SYSTEM

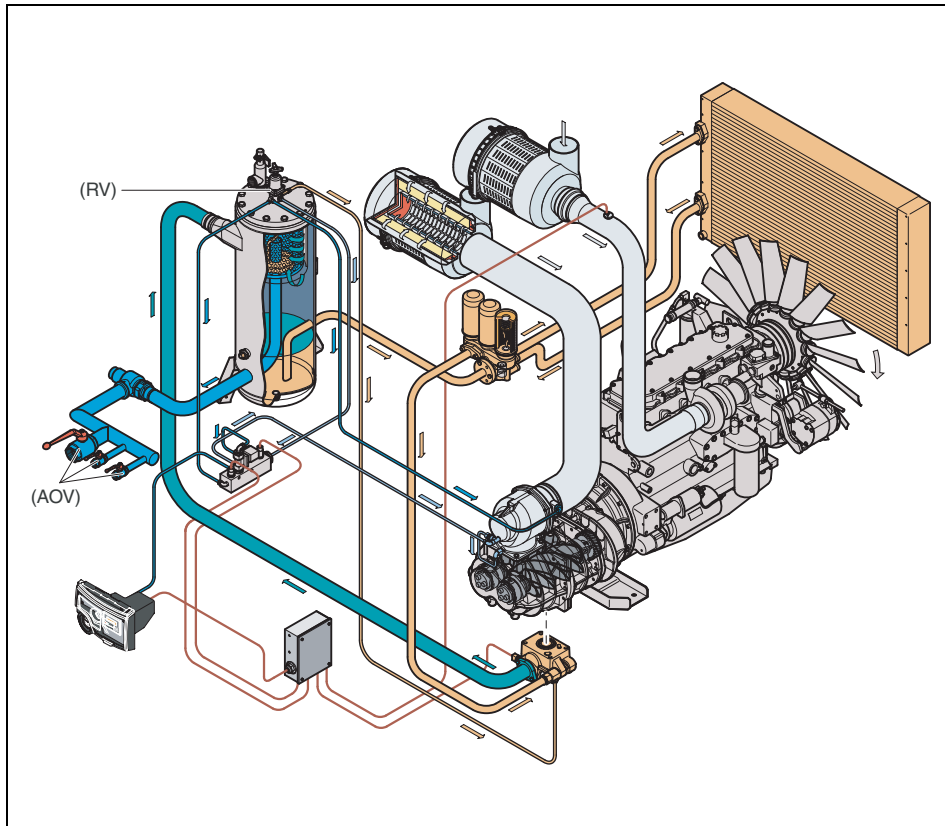

The working pressure is determined by the tension of the spring in the regulating valve (RV). This tension can be increased to raise the pressure and decreased to lower it by turning the adjusting wheel clockwise and anti-clockwise respectively.

To adjust the normal working pressure, proceed as follows:

1. Loosen the lock nut of the regulating valve.
2. Release Regulating Valve (turn out).
3. With the outlet valves (AOV) closed, adjust the regulating valve (RV), until a pressure is reached of nominal pressure + 1.5 bar (+ 22 psi).
4. Lock the regulating valve (RV) by fixing the lock nut.

AIR FILTER ENGINE/COMPRESSOR



The Atlas Copco air filters are specially designed for the application. The use of non-genuine air filters may lead to severe damage of engine and/or compressor element.

Never run the compressor without air filter element.

SERVICING

Always select the service point according to the vacuum indicator or display message. A regular inspection or cleaning as it is sometimes practiced in the field is more likely to be damaging than useful as there is a risk that the element will be damaged and dust will gain access to the engine.

Atlas Copco always recommends exchanging rather than cleaning the filter element in order to avoid damage and ensure maximum engine protection.

MAIN PARTS

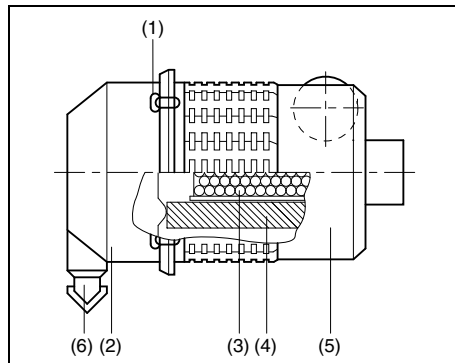

1. Snap clips
2. Dust trap cover
3. Safety cartridge (option)
4. Filter element
5. Filter housing
6. Vacuumator valve

CLEANING THE DUST TRAP

Remove dust daily.

To remove dust from the dust trap pinch the vacuumator valve (6) several times.

CLEANING INSTRUCTIONS FILTER ELEMENT

If element cleaning can not be avoided, care should be taken that the filter element (4) is not washed out. Please note that engine damage can cause considerable costs, which makes the cost of a new filter element seem insignificant.

Safety cartridges (3) can not be cleaned but must be exchanged.

Please note that a cleaned element will never match the service life and performance of a new element.

Take the element from the air filter housing (5) (see section **Replacing the air filter element**).

In order to clean, position a pipe with an end bent by approx. 90° on the end of a compressed-air pistol. The pipe must be long enough to reach the bottom of the filter element. Carefully blow out the filter element with dry compressed air (max. 5 bar (72.5 psi)) from the inside to the outside until there is no more development of dust. The end of the pipe must not touch the element.

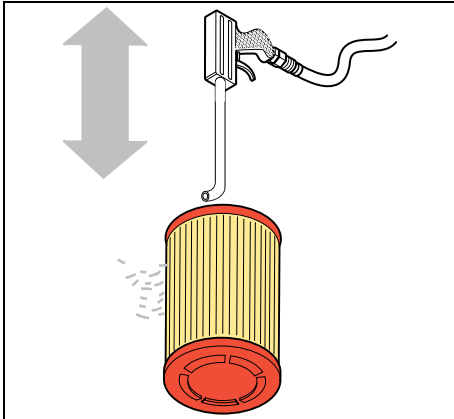

Next carefully examine the element for possible damage. Never beat or knock the element as this will damage it and there will be a danger of damage to the engine.

Carefully clean the inside of the housing and put the element in the housing (see section **Replacing the air filter element**).

REPLACING THE AIR FILTER ELEMENT

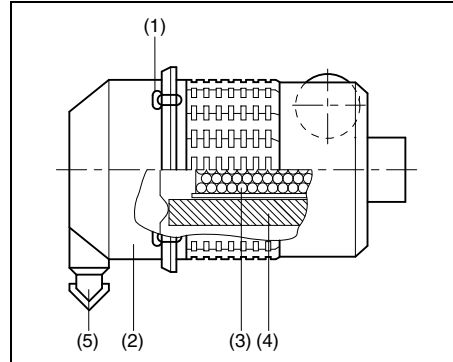

New elements must also be inspected for tears or punctures before installation.

Discard the element (4) when damaged.

A dirty safety cartridge (3) is an indication of a malfunctioning air filter element. Replace the element and the safety cartridge in this case.

The safety cartridge cannot be cleaned.

1. Release the snap clips (1) and remove the dust trap (2). Clean the trap.
2. Remove the element (4) and the safety cartridge.
3. Reassemble in reverse order of dismantling. Make sure the vacuumator valve (5) points down.
4. Inspect and tighten all air intake connections.

AIR RECEIVER

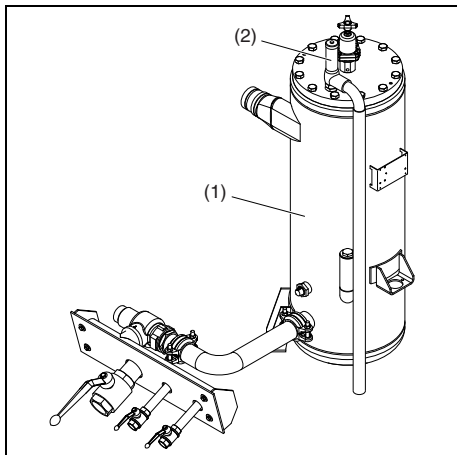

The air receiver (1) is tested according to official standards. Regularly have inspections carried out in conformity with local regulations.



Daily drain condensate.

SAFETY VALVE



All adjustments or repairs are to be done by an authorized representative of the valve supplier, see section Specific safety precautions.

Following checks must be carried out on the safety valve (2):

- A check of the opening of the lifting gear, twice a year.
This can be done by screwing the cap of the valve anti-clockwise.
- A check of the set pressure once a year according to the local regulations. This check cannot be done on the compressor and must be carried out on a proper test bench.

FUEL SYSTEM

PRIMING INSTRUCTIONS



Fuel leaked or spilled onto hot surfaces or electrical components can cause a fire. To help prevent possible injury, turn the “ON/OFF” switch in position “OFF” when changing fuel filters or water separator elements. Clean up fuel spills immediately.

Prime the fuel system in order to fill the fuel filter. Prime the fuel system in order to purge trapped air. The fuel system should be primed under the following conditions:

- Compressor is put in operation for the first time
- Running out of fuel
- Storage
- Replacement of the fuel filter



Do not loosen the fuel lines at the fuel manifold. The fittings may be damaged and/or a loss of priming pressure may occur when the fuel lines are loosened.

DRAINING INSTRUCTIONS

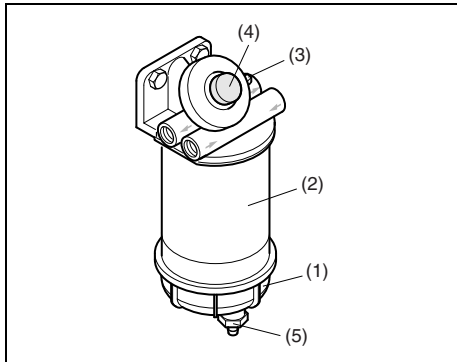

1. Open bowl drain valve (1), operate pump (5) and pump water out.
2. Close drain valve (1).

Replacing the filter elements:

Installation instructions:

1. Drain fuel from the bowl.
2. Remove filter (2, 3), filterelement (4) and separate bowl (2) from element (3).
3. Apply film of gas oil to new bowl seat.
4. Screw bowl (2) to new element (3) tightly by hand.
5. Apply film of gas oil to new element seals.
6. Screw on filter (2, 3) and filterelement (4) tightly by hand.
7. Open head vent and operate pump (5). Close vent when fuel begins to purge.
8. Check for leaks, retighten if necessary.

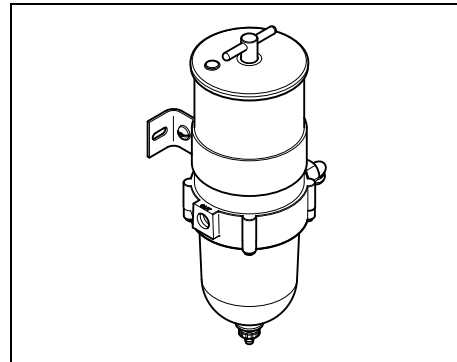

BRAKE ADJUSTMENT



Before jacking up the compressor, connect it to a towing vehicle or attach a weight of minimum 50 kg (110 lb) to the towbar.

BRAKE SHOE ADJUSTMENT

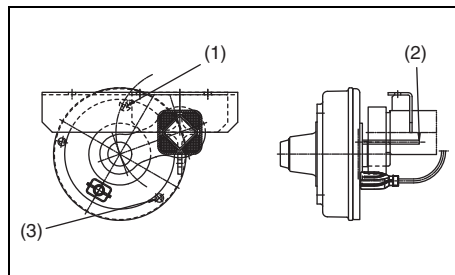

Check the thickness of the brake lining.

- Remove both black plastic plugs (3) one on each wheel.
- Check the thickness of the brake lining.



When the brake lining has been worn to a minimum thickness, the brake shoes have to be replaced (Min. thickness brake lining: 1 mm (0.039 in)).

- After inspection and/or replacement re-insert both plugs (3).

Brake shoe adjustment re-establishes the brake lining-to-drum clearance and compensates for lining wear.

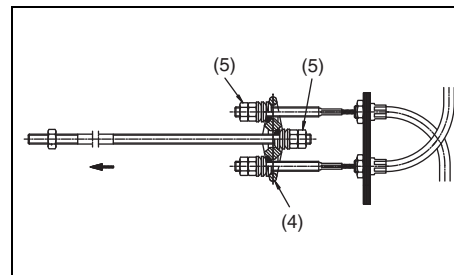

1. Lift and support the compressor. Make sure that all brakes (overrunbrake and hand brake) are off. The brake cables must be free from tension.
2. Lock the swivel cams of the wheel brake from the outside by means of a pin (2) through the hole (Pin \varnothing 4 mm (0.16 in)).
3. Turn the adjusting bolt (1) clockwise with a wrench till the wheel locks up. Center the brake shoes by actuating the parking brake several times.
4. Turn the adjusting bolt (1) anti-clockwise until the wheel is running free in the direction of travel (approx. 1 full turn of the adjusting bolt).
5. Check the position of the equalizer (4) with the parking brake actuated. (Perpendicular position of equalizer = identical clearance of wheel brakes.) Re-adjust the brake shoes, if necessary.
6. To test, slightly apply the parking brake and check identical brake torque on left and right side.
7. Remove locking pin (2). Remove clearance from brake cables.
8. Check all lock nuts (5).

AUDIT PROCEDURE OF BRAKE CABLE ADJUSTMENT

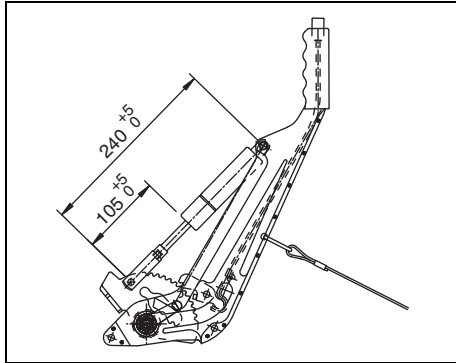

Hand brake (adjustable towbar)

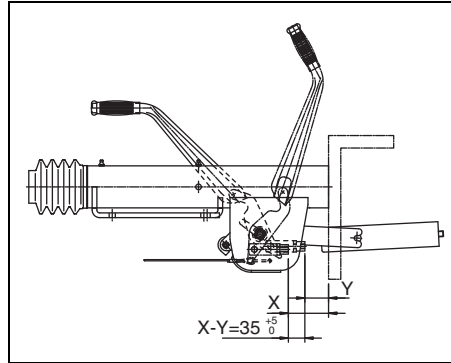

Hand brake (fixed towbar)

1. Check if the towing eye rod of the overrun brake mechanism is in the outmost position.
2. Hand brake lever is just over its top.
3. Push the compressor a few centimeters backwards, so that the brake lever is automatically pulled further up.
4. The cylinder must be in the position of the dimension on the picture.

BRAKE CABLE ADJUSTMENT

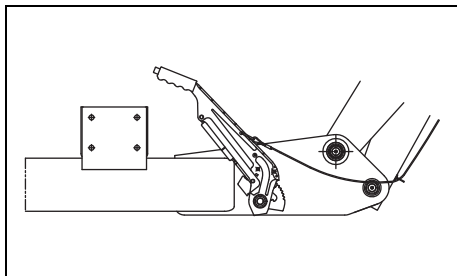

Hand brake lever downward - brake not operated (adjustable towbar)

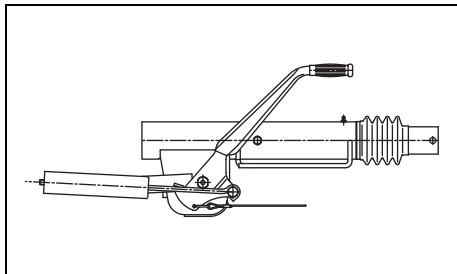

Hand brake lever downward - brake not operated (fixed towbar)

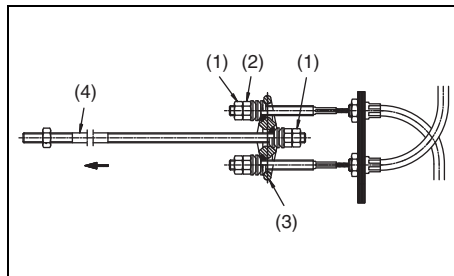

Brake cable arrangement

1. With the towing eye pulled out in the outmost position and the hand brake lever in the downward position, loosen the lock nuts (1). Turn the adjusting nuts and the brake cable nuts (2) clockwise until there is no slack in the brake mechanism. The equalizer (3) must remain perpendicular to the main brake cable (4).
2. Apply the hand brake lever several times and repeat the adjustment. Tighten the nuts with their lock nuts (1). Remove the jack and the blocks.
3. Road test the compressor and brake several times. Check the brake shoe and the brake cable adjustment and if necessary adjust.

TEST PROCEDURE OF BRAKE CABLE ADJUSTMENT

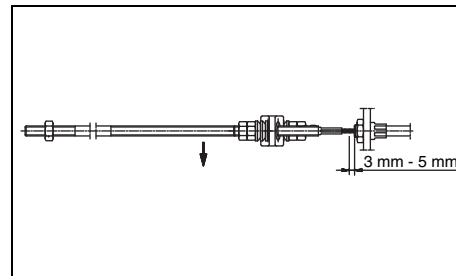

1. Pull main brake cable downwards.
2. The brake cables need 3 mm (0.12 in) to 5 mm (0.2 in) margin (to see on different colors on cables from grease/dust).

Problem solving

It is assumed that the engine is in good condition and that there is adequate fuel flow to the filter and injection equipment.

Make sure that the wires are not damaged and that they are clamped tight to their terminals.

For denomination of switches, relays, etc., see **Electric system**.

See also section **Control panel**.



An electrical fault must be traced by an electrician.

Problem: Compressor capacity or pressure below normal.

Possible faults	Corrective actions
Air consumption exceeds capacity of compressor.	Check equipment connected.
Choked air filter elements (AF).	Remove and inspect elements. Clean or replace, if necessary.
Regulating valve (RV) defective.	Have regulating valve removed and inspected by an Atlas Copco Service representative.
Blow down valve stuck in open position.	Check and correct as necessary.
Loading valve (LV) leaking past O-ring.	With compressor running at max. load speed, disconnect hose leading to unloader. If air leaks from the hose, remove and inspect loading valve. Replace damaged or worn O-rings.
Oil separator element clogged.	Have element removed and inspected by an Atlas Copco Service representative.
Air intake throttle valve remains partially closed.	Remove air filters, air intake manifold and throttle valve spring seat. Withdraw the valve and inspect. Replace parts where necessary. Caution: the spring seat is fixed with 4 short and 2 long setscrews: first remove the short screws, then release the spring tension unscrewing the long ones.
Safety valve (SV) leaking.	Remove and inspect. Replace if not airtight after reinstallation.
Blow-off valve leaking.	Remove and inspect. Replace if necessary.

Problem: Pressure in air receiver rises above maximum and causes safety valve to blow.

Possible faults	Corrective actions
Regulating valve (RV) opens too late or its ball valve spring is broken.	Have regulating valve removed and inspected by an Atlas Copco Service representative.
Air leaks in regulating system.	Check hoses and their fittings. Stop leaks; replace leaking hoses.
Air intake throttle valve does not close for some reason.	Remove air filters, air intake manifold and throttle valve spring seat. Withdraw the valve and inspect. Replace parts where necessary. Caution: the spring seat is fixed with 4 short and 2 long setscrews: first remove the short screws, then release the spring tension unscrewing the long ones.
Minimum pressure valve malfunctioning.	Remove and inspect valve.
Blow-off valve malfunctioning.	Remove and inspect valve.

Problem: After working some time, the unit stops through a shutdown switch.

Possible faults	Corrective actions
Engine oil pressure too low.	Refer to the engine instruction manual.
Compressor or engine overheating.	See corrective actions "Compressor overheating".
Fuel tank contains insufficient fuel.	Fill fuel tank.
Low coolant level.	Top up cooling system.

Problem: Air and oil mist expelled from air filters immediately after stopping.

Possible faults	Corrective actions
Check valve at element outlet.	Remove and inspect. Replace if necessary. Replace air filter elements and safety cartridges. Check the oil level and add oil if necessary. Run the compressor for a few minutes, stop and recheck oil level.
Plunger of oil stop valve jammed.	Remove and inspect. Replace if necessary. Replace air filter elements and safety cartridges. Check the oil level and add oil if necessary. Run the compressor for a few minutes, stop and recheck oil level.

Problem: Compressor overheating.

Possible faults	Corrective actions
Insufficient compressor cooling.	Locate compressor away from walls; when banked with other compressors, leave space between them.
Oil cooler clogged externally.	Clean oil cooler. Refer to section Cleaning coolers .
Oil cooler clogged internally.	Consult Atlas Copco.
Oil filters clogged.	Replace oil filters.
Oil level too low.	Check oil level. Top up with recommended oil if necessary.
Thermostatic by-pass valve remains stuck in opened position.	Remove valve and check for proper opening and closing. Replace if out of order.
Fan blade(s) broken.	Check and correct if necessary.
Oil stop valve malfunctioning.	Remove and inspect valve.
Oil separator element (OS) clogged.	Have element removed and inspected by an Atlas Copco Service representative.

Alternator precautions

1. Never reverse the polarity of the battery or the alternator.
2. Never break any alternator or battery connections while the engine is running.
3. When recharging the battery, disconnect it from the alternator. Before using booster cables to start the engine, be sure of the polarity and connect the batteries correctly.
4. Never operate the engine without the main or voltage sensing cables connected in the circuit.

Available options

Support

A rigid support mounted version for rough construction conditions with the possibility to be mounted on a truck. The installation allows the unit to be put on and taken off the truck daily. It is possible to handle the unit with a forklift.

Fix height towbar with brakes

A fix towbar with integrated parking brake.

Adjustable height towbar with brakes

A dual-hinged articulating towbar assembly, with integrated parking brake.

DIN/NATO/ITA eye

Towing eye according to DIN, NATO or ITA specification.

Road signalization

A road signalisation option compliant with European regulations. The rear lights are protected by the canopy or the bumper bar against external damage.

Road signalization USA

Additional side mounted lights to meet North American road signalization requirements.

Cold weather package (-10°C (14°F) to -25°C (-13°F))

The cold weather package consist of a heater plug, installed in the air-inlet to the engine, a dual approved vessel (EC/ASME) for which the material is approved and certified up to -29 °C (-20 °F), and a blow-off valve on the vessel to minimise the resistance from the oil in the vessel when starting at extreme cold-temperatures. Also synthetic compressor oil is used to improve viscosity at low temperatures.

The installation works on battery voltage and comes together with a timer function. A 5000 Watt (6.7 hp) heater will heat up the engine coolant by means of consuming the onboard fuel. (fuel consumption: 0.62 l/h (0.16 US gal/h) in operation, water pump capacity: +/- 900 l/h (237.8 US gal/h)).

Aftercooler + Water separator

The aftercooler reduces the discharging air temperature to ambient + 10 °C (50 °F).

On units with a cold weather option a bypass on the aftercooler is standard.

Fine Filter (PD)

The fine-filter package completes the after cooler option. It removes particles and oil content down to 0.01 mg/m³ (3.5 oz/1000 cu.ft). Service and replacement of the filter can be done without dismantling other parts or canopy.

Active Coalescing Filter (QD)

For improved quality air an additional oil vapour and odour filter is available reducing the oil content to a maximum of 0.003 mg/m³ (1.06 oz/1000 cu.ft). The active coal filter pack option can be serviced without dismantling other parts or canopy.

Reheater

For applications with a need for dry unsaturated air or where ambient conditions cause risk of freezing tools a reheater can be installed. The reheater can only be installed in combination with the after cooler pack and will increase air discharge temperature close to a+60 °C (140 °F).

Spark arrestor

The spark arrestor option prevents burning particles leaving the exhaust system. This reduces the fire hazard in dry conditions to protect the environment and also enables units to be operated in closed environments where there is a fire risk.

Inlet shutdown

The inlet shutdown provides protection to the diesel engine against over speeding caused by failure of the engine regulator, burning oil from the engine sump due to overfilling or aspiration of combustible fumes in hazardous environments. The inlet shutdown system is fully electronic.

Refinery package

The refinery package is a combination of the Spark arrestor and Inlet shutdown options.

Customer colour canopy (1 colour)

Special colour will apply on all external canopy parts or all internal parts visible from the outside, and wheel rims. The undercarriage, towbar and frame will be painted in black.

Customer colour canopy (2 colours)

Same to Customer colour (1) option, but with two (2) colours for which the customer will provide details.

Customer colour frame (1 colour)

Customer colour for undercarriage, towbar and frame.

COSMOS

Comprehensive Service and Monitoring System for global remote monitoring and fleet management.

FuelXpert

The FuelXpert optimizes the fuel consumption during operation at partial load conditions.

Technical specifications

TORQUE VALUES

GENERAL TORQUE VALUES

The following tables list the recommended torques applied for general applications at assembly of the compressor.

For hexagon screws and nuts with strength grade 8.8

Thread size	Torque value (Nm / lbf.ft)
M6	9 (6.64)
M8	23 (16.97)
M10	46 (34.69)
M12	80 (59.04)
M14	125 (92.25)
M16	205 (151.29)

For hexagon screws and nuts with strength grade 12.9

Thread size	Torque value (Nm / lbf.ft)
M6	15 (11.07)
M8	39 (28.78)
M10	78 (57.56)
M12	135 (99.63)
M14	210 (154.98)
M16	345 (254.61)

CRITICAL TORQUE VALUES

Assemblies	Torque value (Nm / lbf.ft)
Axles to frame:	
Wheel nuts	270 (199.26)
Bolts, front axle/frame	205 (151.29)
Bolts, rear axle/frame	205 (151.29)
Compressor to frame:	
Bolts, elements/gear casing	46 (33.95)
Bolts, elements/support	80 (59.04)
Bolts, support/buffer	205 (151.29)
Bolts, buffer/frame	80 (59.04)
Engine to frame:	
Bolts, engine/support	205 (151.29)
Bolts, support/buffer	46 (33.95)
Bolts, buffer/frame	23 (16.97)
Lifting beams to frame:	
Bolts, lifting beams/yoke (M12)	125 (92.25)
Bolts, lifting beams/yoke (M16)	205 (151.29)
Bolts, lifting beams/A-Frames	205 (151.29)
Bolts, A-Frames/frame	205 (151.29)
Hose clamps:	
Pebra hose clamps on all IC/radiator hoses	12 (8.85)



Secure the drain cock and tank cap of the fuel tank handtight.

COMPRESSOR / ENGINE SPECIFICATIONS

REFERENCE CONDITIONS

Designation		XAMS 407 Cd - XAMS 850 CD7	XATS 377 Cd - XATS 800 CD7	XAHS 347 Cd - XAHS 710 CD7	XAVS 307 Cd - XAVS 650 CD7
Absolute inlet pressure	bar(e)	1	1	1	1
	psi	14.5	14.5	14.5	14.5
Relative air humidity	%	-	-	-	-
Air inlet temperature	°C	20	20	20	20
	°F	68	68	68	68
Nominal effective working pressure	bar(e)	8.6	10.3	12	14
	psi	125	149	174	203

The inlet conditions are specified at the air inlet grating outside the canopy.

LIMITATIONS

Designation		XAMS 407 Cd - XAMS 850 CD7	XATS 377 Cd - XATS 800 CD7	XAHS 347 Cd - XAHS 710 CD7	XAVS 307 Cd - XAVS 650 CD7
Minimum effective receiver pressure	bar(e)	4	4	4	4
	psi	58	58	58	58
Maximum effective receiver pressure, compressor unloaded	bar(e)	10.1	11.8	13.5	15.5
	psi	146	171	196	225
Maximum ambient temperature at sea level	°C	45	45	45	45
	°F	113	113	113	113
Minimum starting temperature	°C	-10	-10	-10	-10
	°F	14	14	14	14
Minimum starting temperature, with coldstart equipment ¹⁾	°C	NA	NA	NA	NA
	°F	NA	NA	NA	NA
Altitude capability		see curves			

¹⁾ Cold start equipment not available at time of release.

ALTITUDE UNIT PERFORMANCE CURVE

Max. allowable working pressure as a function altitude and ambient temperature.

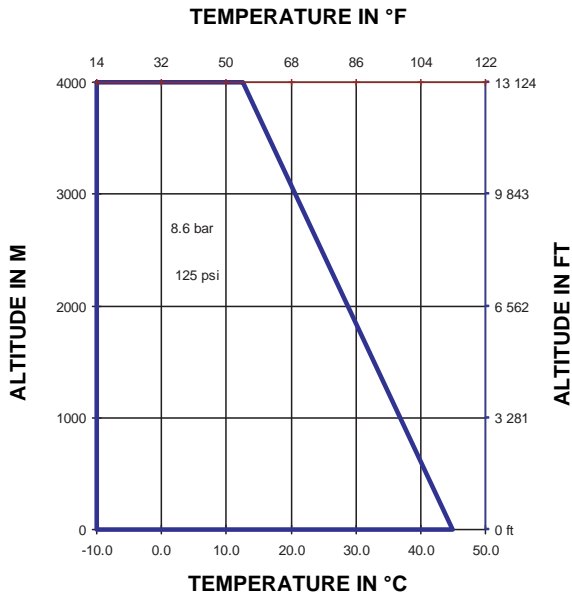

XAMS 407
XAMS 850 CD7

9/jul/07

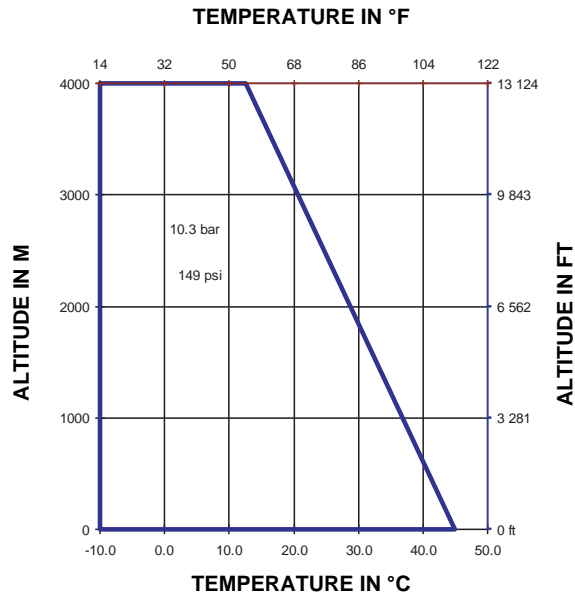

XATS 377
XATS 800 CD7

9/jul/07

ALTITUDE UNIT PERFORMANCE CURVE

Max. allowable working pressure as a function altitude and ambient temperature.

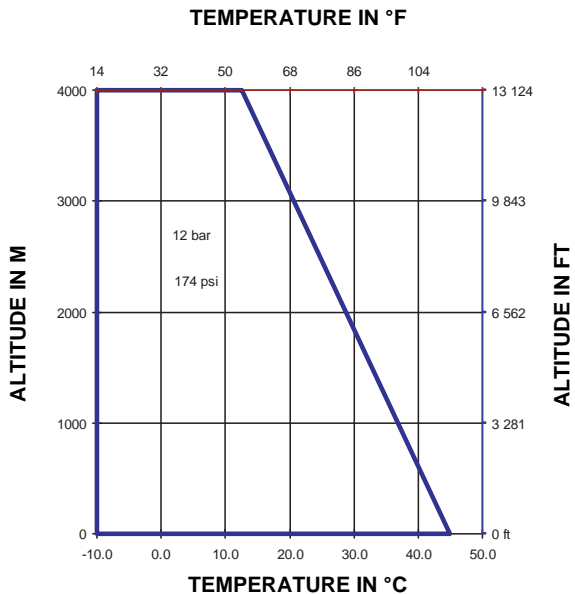

XAHS 347
XAHS 710 CD7

9/jul/07

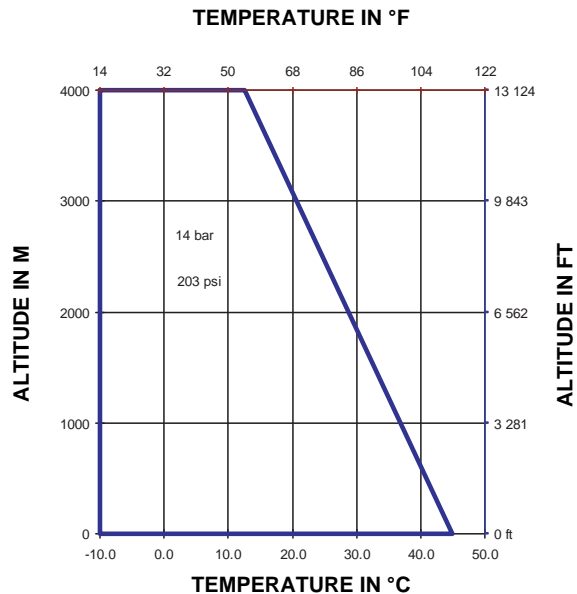

XAVS 307
XAVS 650 CD7

9/jul/07

PERFORMANCE DATA

At reference conditions, if applicable, and at normal shaft speed, unless otherwise stated.

Designation			XAMS 407 Cd - XAMS 850 CD7	XATS 377 Cd - XATS 800 CD7	XAHS 347 Cd - XAHS 710 CD7	XAVS 307 Cd - XAVS 650 CD7
Engine shaft speed, normal and maximum		r/min	2000	2000	2000	2000
Engine shaft speed, compressor unloaded		r/min	1300	1300	1300	1300
Free air delivery ¹⁾		l/s	401	369	343	310
		cfm	850	782	727	657
Fuel consumption						
- at 100% FAD	Fuel expert	kg/h	39.9	39.7	38.8	39.3
		lb/h	88.0	87.5	85.5	86.6
	No Fuel expert	kg/h	39.9	39.7	38.8	39.3
		lb/h	88.0	87.5	85.5	86.6
- at 75% FAD	Fuel expert	kg/h	29.4	29.4	29.6	29.4
		lb/h	64.8	64.8	65.3	64.8
	No Fuel expert	kg/h	35.6	35.8	36.1	35.9
		lb/h	78.5	78.9	79.6	79.1
- at 50% FAD	Fuel expert	kg/h	22.3	22.5	22.9	22.9
		lb/h	49.2	49.6	50.5	50.5
	No Fuel expert	kg/h	29.2	29.6	30.2	30.3
		lb/h	64.4	65.3	66.6	66.8
- at 25% FAD	Fuel expert	kg/h	19.0	19.5	20.0	20.2
		lb/h	41.9	43.0	44.1	44.5
	No Fuel expert	kg/h	21.7	22.4	23.1	23.5
		lb/h	47.8	49.4	50.9	51.8

Designation			XAMS 407 Cd - XAMS 850 CD7	XATS 377 Cd - XATS 800 CD7	XAHS 347 Cd - XAHS 710 CD7	XAVS 307 Cd - XAVS 650 CD7
- at unload	Fuel expert	kg/h	16.8	17.6	18.3	18.8
		lb/h	37.0	38.8	40.3	41.4
	No Fuel expert	kg/h	16.8	17.6	18.3	18.8
		lb/h	37.0	38.8	40.3	41.4
Specific fuel consumption at 100% FAD		g/m ³	27.6	29.9	31.4	35.2
		lb/1000 cu.ft	1.73	1.87	1.96	2.20
Typical oil content of compressed air		mg/m ³	< 5	< 5	< 5	< 5
		oz/1000 cu.ft	< 0.005	< 0.005	< 0.005	< 0.005
Engine oil consumption (maximum)		g/h	99	99	99	99
		oz/h	3.49	3.49	3.49	3.49
Compressed air temperature at outlet valve		°C	71	71	71	71
		°F	160	160	160	160
Noise level						
- Sound pressure level (LP), measured acc. to ISO 2151 under free field conditions at 7 m distance		dB(A)	72	72	72	72
- Sound power level (LW) complies with 2000/14/EC		dB(A)	100	100	100	100

¹⁾ Free Air Delivery (volume flow rate) is measured according to ISO 1217 ed.3 1996 annex D

Tolerance:

- +/- 5% 25 l/s (53 cfm) < FAD < 250 l/s (530 cfm)
- +/- 4% 250 l/s (530 cfm) < FAD

The international standard ISO 1217 corresponds to following national standards:

- British BSI 1571 part 1
- German DIN 1945 Part 1
- Swedish SS-ISO 1217
- American ANSI PTC9

DESIGN DATA

Compressor element

Designation	
Number of compression stages	1

Engine

Designation		XAMS 407 Cd - XAMS 850 CD7, XATS 377 Cd - XATS 800 CD7, XAHS 347 Cd - XAHS 710 CD7, XAVS 307 Cd - XAVS 650 CD7
Make		Caterpillar
Type		C7
Coolant		Liquid
Number of cylinders		6
Bore	mm	110
	in	4.33
Stroke	mm	127
	in	5.00
Swept volume	l	7.2
	cu.in	439.3
Output acc. to DIN 6271 at normal shaft speed	kW	186
	hp	249
- Load factor	%	80

Designation		XAMS 407 Cd - XAMS 850 CD7, XATS 377 Cd - XATS 800 CD7, XAHS 347 Cd - XAHS 710 CD7, XAVS 307 Cd - XAVS 650 CD7
Capacity of oil sump:		
- Initial fill	l	26
	US gal	6.87
- Refill (max.) ¹⁾	l	
	US gal	
Capacity of cooling system	l	49
	US gal	12.95

¹⁾ With filter change.

Compressor

Designation		XAMS 407 Cd - XAMS 850 CD7, XATS 377 Cd - XATS 800 CD7, XAHS 347 Cd - XAHS 710 CD7, XAVS 307 Cd - XAVS 650 CD7
Capacity of compressor oil system	l	52
	US gal	13.74
Net capacity of air receiver	l	63.5
	US gal	16.78
Capacity of fuel tank ²⁾	l	293
	US gal	77.41
Air volume at inlet grating (approx.) ¹⁾	m ³ /s	6.8
	cuft/s	240

¹⁾ Air required for engine and compressor element cooling, for combustion and for compression.

²⁾ Option + 100 l (26.4 US gal)

Compressor dimensions with brakes and adjustable towbar

Designation		All units
Length	mm	4945
	in	197.8
Width	mm	1987
	in	79.5
Height	mm	2059
	in	82.4
Weight (ready-to-operate)		See indication on dataplate

Dataplate

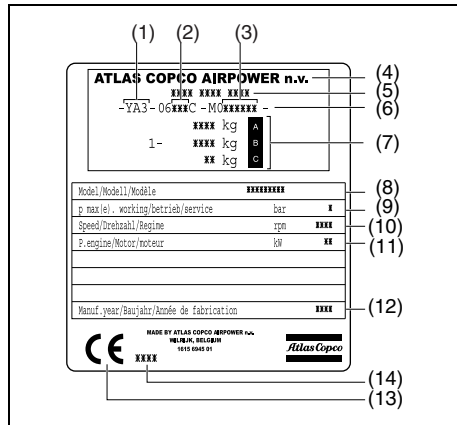

- 1 Company code
- 2 Product code
- 3 Unit serial number
- 4 Name of the manufacturer
- 5 EEC or national type approval number
- 6 Vehicle identification number
- 7 **A** Maximum permitted total weight of the vehicle
B Maximum permitted axle load
C Maximum permitted load on the towing eye
- 8 Model
- 9 Working pressure
- 10 Speed
- 11 Engine power
- 12 Manufacturing year
- 13 CE mark in accordance with Machine Directive 89/392 EC
- 14 Register number or number of notified body

Legislation Size 2 LP

PARTS, SUBJECTED TO PRESSURE EQUIPMENT DIRECTIVE 97/23/EC, CAT. II AND ABOVE

Safety valve: cat. IV

		XAMS 407 Cd - XAMS 850 CD7	XATS 377 Cd - XATS 800 CD7	XAHS 347 Cd - XAHS 710 CD7	XAVS 307 Cd - XAVS 650 CD7
Set pressure	bar(e)	16	16	18	18
	psi	232	232	261	261
Design temperature	°C	130	130	130	130
	°F	266	266	266	266

PARTS, SUBJECTED TO SIMPLE PRESSURE VESSEL DIRECTIVE 87/404/EC

Air Oil separator

		Standard	Cold start equipment ¹⁾
Design pressure	bar(e)	18	18
	psi	261	261
Design temperature max.	°C	130	130
	°F	266	266
Design temperature min.	°C	-10	-25
	°F	14	-13
Volume	l	92	92
	US gal	24.3	24.3

PARTS, SUBJECTED TO CAT. I AND COVERED BY THE MACHINE DIRECTIVE 89/392/EC

All other parts

PARTS, SUBJECTED TO ART. I, PARAGRAPH 3.3

All other parts

Disposal

GENERAL

When developing products and services, Atlas Copco tries to understand, address, and minimize the negative environmental effects that the products and services may have, when being manufactured, distributed, and used, as well as at their disposal.

Recycling and disposal policy are part of the development of all Atlas Copco products. Atlas Copco company standards determine strict requirements.

Selecting materials the substantial recyclability, the disassembly possibilities and the separability of materials and assemblies are considered as well as the environmental perils and dangers to health during the recycling and disposal of the unavoidable rates of not recyclable materials.

Your Atlas Copco compressor consists for the most part of metallic materials, that can be remelted in steelworks and smelting works and that is therefore almost infinite recyclable. The plastic used is labelled; sorting and fractioning of the materials for recycling in the future is foreseen.



This concept can only succeed with your help. Support us by disposing professionally. By assuring a correct disposal of the product you help to prevent possible negative consequences for environment and health, that can occur with an inappropriate waste handling.

Recycling and re-usage of material helps to preserve natural resources.

DISPOSAL OF MATERIALS

Dispose contaminated substances and material separately, according to local applicable environmental legislations.

Before dismantling a machine at the end of its operating lifetime drain all fluids and dispose of according the applicable local disposal regulations.

Remove the batteries. Do not throw batteries into the fire (explosion risk) or into the residual waste. Separate the machine into metal, electronics, wiring, hoses, insulation and plastic parts.

Dispose all components according to the applicable disposal regulations.

Remove spilled fluid mechanically; pick up the rest with absorbing agent (for example sand, sawdust) and dispose it according the applicable local disposal regulations. Do not drain into the sewage system or surface water.

Notes:

