

Operation & Maintenance Manual

HYDRAULIC
EXCAVATOR

PC45MR-5
PC55MR-5

SERIAL NUMBERS PC45MR-30403 and up
 PC55MR-20398

⚠ WARNING

Unsafe use of this machine may cause serious injury or death. Operators and maintenance personnel must read this manual before operating or maintaining this machine. This manual should be kept near the machine for reference and periodically reviewed by all personnel who will come into contact with it.

NOTICE

Komatsu has Operation & Maintenance Manuals written in some other languages. If a foreign language manual is necessary, contact your local distributor for availability.

KOMATSU

FOREWORD

 **WARNING**

Komatsu recommends that any service parts used for maintenance, repair or replacement of emission control systems be genuine new Komatsu or Komatsu approved parts or Komatsu approved rebuilt parts or assemblies or others parts of equivalent quality, and that the engine be serviced by an authorized Komatsu distributor. Failure to follow these recommendations could result in ineffective service, damage to the product, or safety risks (including serious personal injury or death).

In the United States, the owner may choose to have maintenance, replacement or repair of the emissions-related parts performed by a facility other than an authorized Komatsu distributor.

CALIFORNIA

Proposition 65 Warning

Diesel engine exhaust and some of its constituents are known to the State of California to cause cancer, birth defects, and other reproductive harm.

CALIFORNIA

Proposition 65 Warning

Battery posts, terminals and related accessories contain lead and lead compounds, chemicals known to the State of California to cause cancer, birth defects and reproductive harm.

Wash hands after handling.

READ THIS MANUAL

This manual gives details of the operation and methods of inspection and maintenance for this machine that must be obeyed in order to use the machine safely. Most accidents are caused by the failure to follow fundamental safety rules for the operation and maintenance of machines.

Read, understand and follow all precautions and warnings in this manual and on the machine before performing operation and maintenance. Failure to do so may result in serious injury or death.

Komatsu cannot predict every circumstance that might involve a potential hazard when the machine is used. Therefore, the safety messages in this manual and on the machine may not include all possible safety precautions.

If you perform any operation, inspection, or maintenance under conditions that are not described in this manual, understand that it is your responsibility to take the necessary precautions to ensure safety. In no event should you or others engage in the prohibited uses or actions described in this manual. It is dangerous to perform improper operation and maintenance of the machine. It may cause serious injury or death.

If you sell the machine, be sure to give this manual to the new owner together with the machine.

Always keep this Operation and Maintenance Manual in the storing location so that all relevant personnel can read it at any time.

Keep it in the pocket inside the cover of toolbox under the operator's seat.

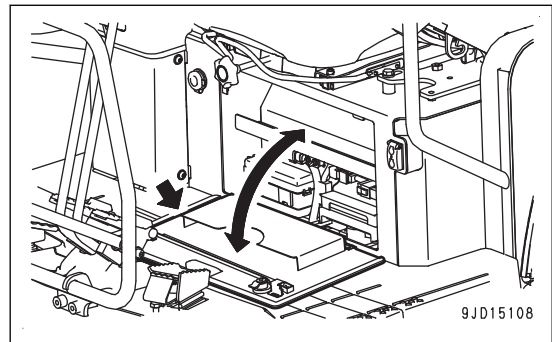

If this manual is lost or damaged, contact Komatsu or your Komatsu distributor and tell them about the machine model name and the serial No. immediately to arrange for its replacement.

For details regarding the machine model name and the serial No., see the machine serial No. plate. In order to arrange the proper Operation and Maintenance Manual, you will need to provide the machine model name and the serial No.

This manual uses the International System of Units (SI) for units of measurement. For reference, units that have been used in the past are given in { }.

The explanations, values, and illustrations in this manual have been prepared based on the latest information available as of the date of its publication. Continuing improvements in the design of this machine may lead to additional changes that are not reflected in this manual. Consult Komatsu or your Komatsu distributor for the latest available information concerning your machine or with questions regarding information contained in this manual.

The numbers in the illustrations correspond to the numbers in () in the text. (Example: 1 → (1))

Komatsu delivers machines that comply with all applicable regulations and standards of the country to which it has been shipped. If this machine has been purchased in another country, it may lack certain safety devices and specifications that are necessary for use in your country. If there is any question about whether your product complies with the applicable standards and regulations of your country, consult your Komatsu distributor before operating the machine.

SAFETY INFORMATION

To enable you to use the machine safely, and to prevent personal injury to operators, service personnel or bystanders, the precautions and warnings included in this manual and the safety signs attached to the machine must always be observed.

To identify important safety messages in the manual and on the machine labels, the following signal words are used.

The "Safety Alert Symbol" identifies important safety messages on machines, in manuals, and elsewhere. When you see this symbol, be alert to the risk of personal injury or death. Follow the instructions in the safety message.

**DANGER**

This signal word indicates an imminently hazardous situation which, if not avoided, will result in death or serious injury.

**WARNING**

This signal word indicates a potentially hazardous situation which, if not avoided, could result in death or serious injury.

**CAUTION**

This signal word indicates a potentially hazardous situation which, if not avoided, may result in minor or moderate injury. It may also be used to alert against unsafe practices that may cause property damage.

The following signal words are used to alert you to information that must be followed to avoid damage to the machine.

NOTICE

If precautions described are not observed, the machine may be damaged or the service life may be reduced.

REMARK

This word is used for information that is useful to know.

INTRODUCTION

MAIN USE OF MACHINE

This Komatsu machine is designed to be used mainly for the following work:

- Digging work
- Ditching work
- Loading work
- Leveling work
- Demolition work

For details of work procedure, see OPERATION, "RECOMMENDED APPLICATIONS".

DIRECTIONS OF MACHINE

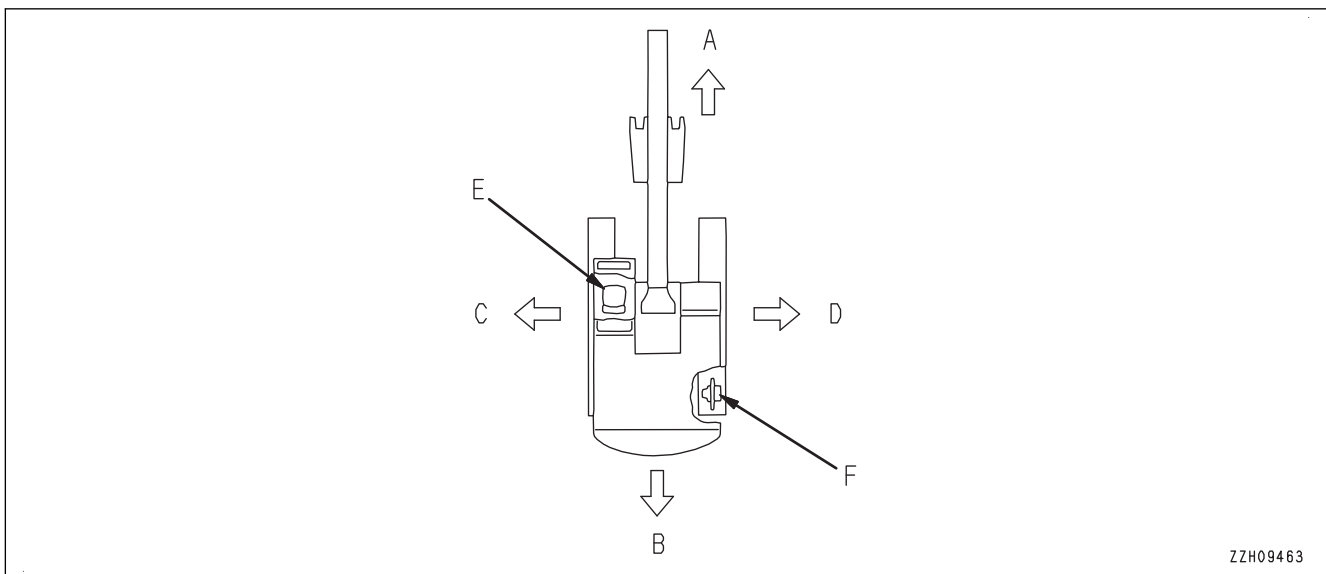

(A) Front

(B) Rear

(C) Left

(D) Right

(E) Operator's seat

(F) Sprocket

In this manual, the terms front, rear, left, and right refer to the travel direction as seen from the operator's seat when the operator's seat is facing the front and the sprocket is at the rear of the machine.

PROTECTIVE STRUCTURES

This machine is equipped with a structure to protect the operator (ROPS) conforming to ISO3471:2008.

PRODUCT INFORMATION

When requesting service or ordering replacement parts, inform your Komatsu distributor of the following items.

LOCATION OF PRODUCT IDENTIFICATION NUMBER (PIN)/MACHINE SERIAL NO. PLATE

It is located on the front left of revolving frame.

The design of the nameplate varies according to the district.

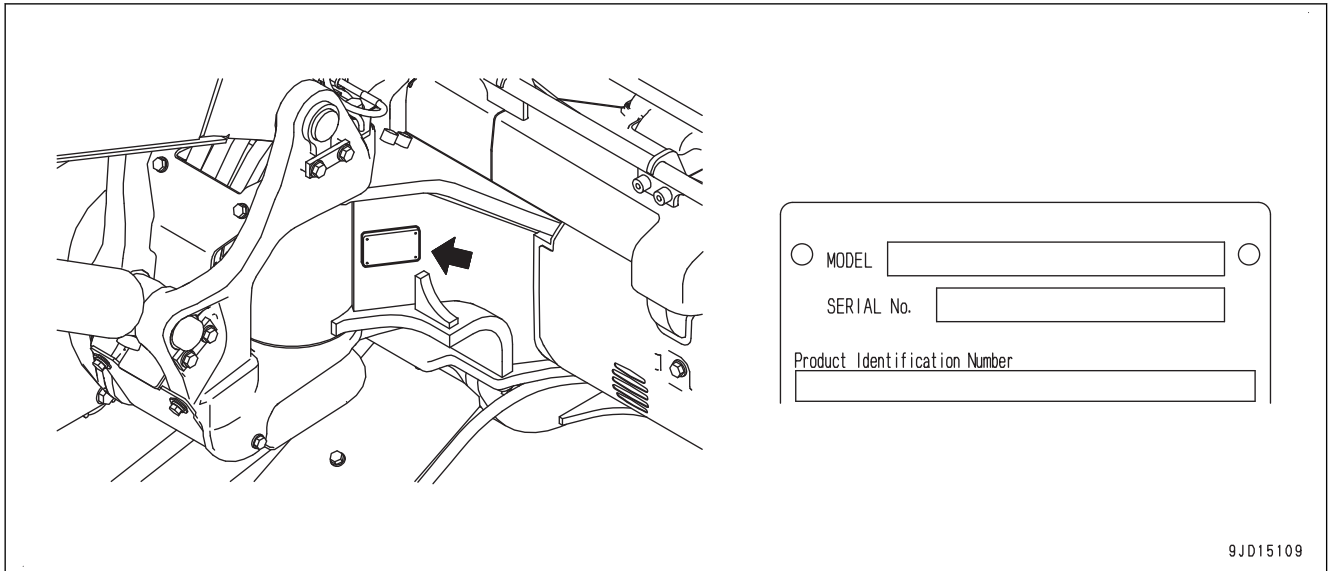

LOCATION OF ENGINE NUMBER PLATE

This is located on the side of the intake manifold.

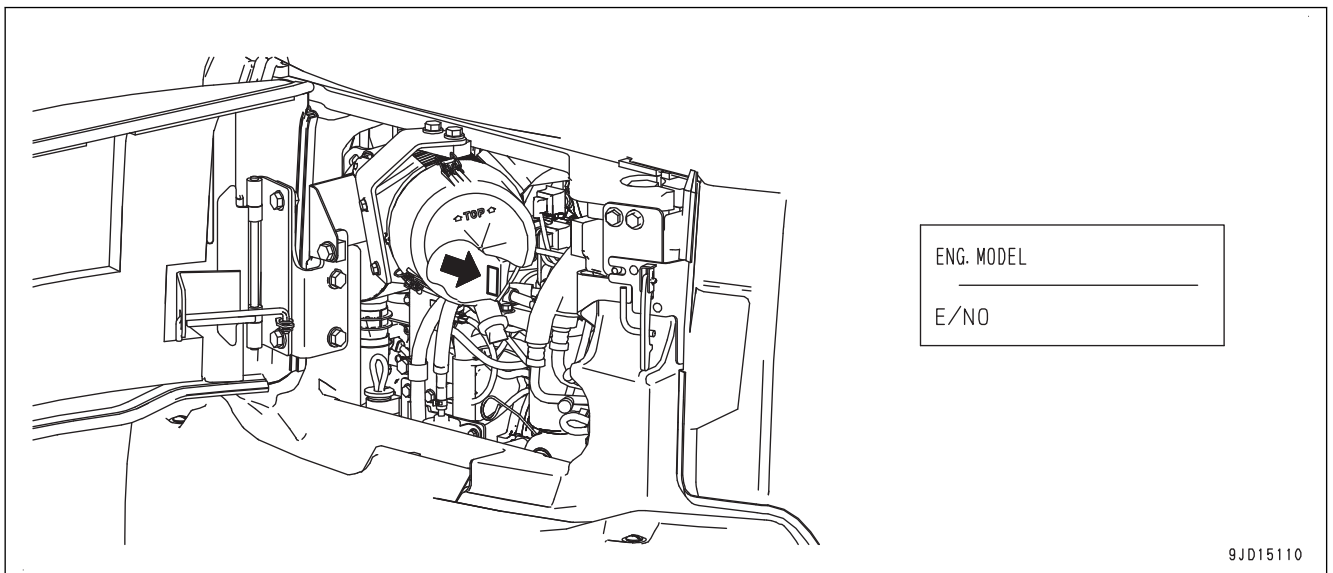

SERVICE METER LOCATION

This is displayed on the machine monitor.

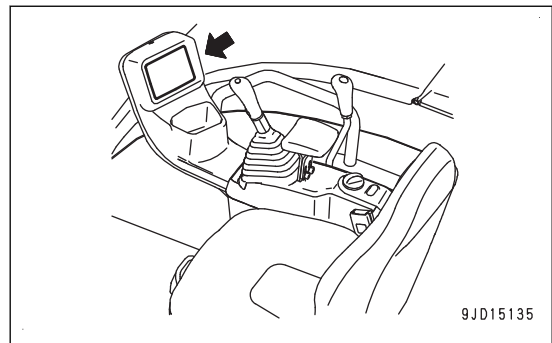

YOUR MACHINE SERIAL NUMBERS AND DISTRIBUTOR

Machine serial No.	
Engine serial No.	
Product identification number (PIN)	
Distributor name	
Address	
Phone/Fax	
Service personnel	

TABLE OF CONTENTS

FOREWORD.....	1-1
READ THIS MANUAL	1-2
SAFETY INFORMATION	1-3
INTRODUCTION	1-4
MAIN USE OF MACHINE	1-4
DIRECTIONS OF MACHINE.....	1-4
PROTECTIVE STRUCTURES.....	1-4
PRODUCT INFORMATION.....	1-5
LOCATION OF PRODUCT IDENTIFICATION NUMBER (PIN)/MACHINE SERIAL NO. PLATE	1-5
LOCATION OF ENGINE NUMBER PLATE	1-5
SERVICE METER LOCATION.....	1-6
YOUR MACHINE SERIAL NUMBERS AND DISTRIBUTOR.....	1-6
SAFETY.....	2-1
SAFETY LABELS	2-2
LOCATION OF SAFETY LABELS.....	2-3
CONTENTS OF SAFETY LABELS	2-6
GENERAL PRECAUTIONS COMMON TO OPERATION AND MAINTENANCE	2-13
PRECAUTIONS BEFORE STARTING OPERATION.....	2-13
PREPARATIONS FOR SAFE OPERATION	2-14
PRECAUTIONS TO PREVENT FIRE.....	2-16
PRECAUTIONS WHEN GETTING ON OR OFF MACHINE.....	2-18
DO NOT GET CAUGHT IN WORK EQUIPMENT	2-19
PRECAUTIONS RELATED TO PROTECTIVE STRUCTURES.....	2-20
PROTECTION AGAINST FALLING, FLYING OR INTRUDING OBJECTS.....	2-21
UNAUTHORIZED MODIFICATION	2-21
PRECAUTIONS RELATED TO ATTACHMENTS AND OPTIONS	2-21
PRECAUTIONS RELATED TO CAB GLASS	2-21
PRECAUTIONS WHEN RUNNING ENGINE INSIDE BUILDING	2-22
PRECAUTIONS FOR OPERATION	2-23
PRECAUTIONS FOR JOBSITE.....	2-23
START ENGINE.....	2-26
PRECAUTIONS FOR OPERATION	2-28
PRECAUTIONS FOR TRANSPORTATION.....	2-36
TOWING AND BEING TOWED.....	2-37
LIFTING OPERATION BY USING BUCKET WITH HOOK.....	2-38
PRECAUTIONS FOR MAINTENANCE	2-39
PRECAUTIONS BEFORE STARTING INSPECTION AND MAINTENANCE	2-39
PRECAUTIONS FOR CHECK AND MAINTENANCE	2-43
OPERATION.....	3-1
GENERAL VIEW.....	3-2
MACHINE EQUIPMENT NAME	3-2
CONTROLS AND GAUGES NAMES.....	3-4
OTHER EQUIPMENT NAME	3-7
EXPLANATION OF COMPONENTS.....	3-9
EXPLANATION OF MACHINE MONITOR EQUIPMENT	3-9
SWITCHES.....	3-77
CONTROL LEVERS AND PEDALS	3-86
OTHER EQUIPMENT	3-94
MACHINE OPERATIONS AND CONTROLS	3-131
CHECKS AND ADJUSTMENT BEFORE STARTING ENGINE	3-131
METHOD FOR STARTING ENGINE.....	3-158
METHOD FOR OPERATIONS AND CHECKS AFTER STARTING ENGINE	3-161
METHOD FOR STOPPING ENGINE	3-169
METHOD FOR STARTING MACHINE (TRAVEL FORWARD AND REVERSE) AND STOPPING MACHINE	3-170
METHOD FOR STEERING MACHINE.....	3-176

METHOD FOR SWINGING MACHINE	3-178
METHOD FOR OPERATING WORK EQUIPMENT	3-179
HANDLE WORKING MODE	3-182
PROHIBITED OPERATIONS	3-183
PRECAUTIONS FOR OPERATION	3-188
PRECAUTIONS FOR WORKING ON SLOPE	3-190
METHOD FOR ESCAPING FROM MUD	3-192
RECOMMENDED APPLICATIONS.....	3-193
METHOD FOR REPLACING BUCKET	3-195
METHOD FOR PARKING MACHINE.....	3-197
METHOD FOR CHECKING AFTER FINISHING WORK.....	3-199
LOCK.....	3-199
HANDLE AIR CONDITIONER.....	3-210
EXPLANATION OF AIR CONDITIONER EQUIPMENT.....	3-210
METHOD FOR OPERATING AIR CONDITIONER.....	3-212
HANDLE RUBBER AND ROAD LINERS SHOES.....	3-214
RECOMMENDED USE OF RUBBER AND ROAD LINERS SHOES.....	3-214
COMPARISON OF RUBBER ,ROAD LINERS SHOES AND STEEL SHOES.....	3-214
WARRANTY OF RUBBER AND ROAD LINERS SHOES	3-214
PROHIBITED OPERATIONS WHEN USING RUBBER AND ROAD LINERS SHOES.....	3-215
PRECAUTIONS FOR USING RUBBER AND ROAD LINERS SHOES	3-216
TRANSPORTATION.....	3-219
PRECAUTIONS FOR TRANSPORTING MACHINE	3-219
SELECT TRANSPORTATION METHOD.....	3-219
LOADING AND UNLOADING WITH TRAILER	3-220
METHOD FOR LIFTING MACHINE	3-226
COLD WEATHER OPERATION.....	3-229
COLD WEATHER OPERATION INFORMATION	3-229
PRECAUTIONS AFTER DAILY WORK COMPLETION IN COLD WEATHER.....	3-231
AFTER COLD WEATHER SEASON	3-231
PRECAUTIONS FOR LONG-TERM STORAGE	3-232
PREPARATION FOR LONG-TERM STORAGE.....	3-232
MAINTENANCE DURING LONG-TERM STORAGE.....	3-233
STARTING MACHINE AFTER LONG-TERM STORAGE	3-233
TROUBLES AND ACTIONS	3-234
ACTIONS WHEN RUNNING OUT OF FUEL	3-234
PHENOMENA THAT ARE NOT FAILURES	3-236
PRECAUTIONS FOR TOWING MACHINE.....	3-237
PRECAUTIONS FOR SEVERE JOB CONDITION.....	3-237
PRECAUTIONS FOR DISCHARGED BATTERY	3-238
OTHER TROUBLE.....	3-244
MAINTENANCE.....	4-1
PRECAUTIONS FOR MAINTENANCE	4-2
CHECK SERVICE METER READING	4-2
KOMATSU GENUINE REPLACEMENT PARTS	4-2
KOMATSU GENUINE LUBRICANTS.....	4-2
ALWAYS USE CLEAN WASHER FLUID	4-2
FRESH AND CLEAN LUBRICANTS	4-2
CHECK DRAINED OIL AND USED FILTER.....	4-2
PRECAUTIONS FOR REFILLING OIL OR FUEL	4-2
PRECAUTIONS FOR WELDING	4-2
DO NOT DROP THINGS INSIDE MACHINE	4-2
PRECAUTIONS FOR KDPF	4-2
DUSTY JOBSITES.....	4-3
AVOID MIXING OIL.....	4-3
LOCK INSPECTION COVERS	4-3
PRECAUTIONS WHEN SWINGING BOOM	4-3
PRECAUTIONS WHEN OPENING AND CLOSING COOLING COVER.....	4-3

BLEED AIR FROM HYDRAULIC CIRCUIT	4-3
PRECAUTIONS WHEN INSTALLING HYDRAULIC HOSES	4-3
CHECKS AFTER INSPECTION AND MAINTENANCE.....	4-4
FIX FLOOR SECURELY	4-4
FUEL AND LUBRICANTS TO MATCH THE AMBIENT TEMPERATURE.....	4-4
OUTLINE OF MAINTENANCE.....	4-5
HANDLE OIL, FUEL, COOLANT, AND PERFORMING OIL CLINIC	4-5
HANDLE ELECTRICAL COMPONENTS	4-9
HANDLE HYDRAULIC COMPONENTS.....	4-10
STANDARD TIGHTENING TORQUE FOR BOLTS AND NUTS	4-11
MAINTENANCE SCHEDULE.....	4-13
MAINTENANCE SCHEDULE TABLE.....	4-13
MAINTENANCE INTERVAL FOR HYDRAULIC BREAKER	4-14
MAINTENANCE PROCEDURE	4-15
INITIAL 10 HOURS MAINTENANCE (ONLY FOR THE FIRST 100 HOURS)	4-15
WHEN REQUIRED	4-16
CHECKS BEFORE STARTING.....	4-63
EVERY 100 HOURS MAINTENANCE	4-64
EVERY 250 HOURS MAINTENANCE	4-67
EVERY 500 HOURS MAINTENANCE	4-69
EVERY 1000 HOURS MAINTENANCE	4-85
EVERY 1500 HOURS MAINTENANCE	4-88
EVERY 2000 HOURS MAINTENANCE	4-89
EVERY 3000 HOURS MAINTENANCE	4-98
EVERY 4000 HOURS MAINTENANCE	4-99
EVERY 6000 HOURS MAINTENANCE	4-101
SPECIFICATIONS	5-1
SPECIFICATIONS	5-2
SPECIFICATIONS: PC45MR-5.....	5-2
SPECIFICATIONS: PC55MR-5.....	5-4
ATTACHMENTS AND OPTIONS	6-1
PRECAUTIONS FOR USING ATTACHMENT AND OPTIONS.....	6-2
PRECAUTIONS WHEN SELECTING	6-2
READ THE OPERATION AND MAINTENANCE MANUAL THOROUGHLY.....	6-2
PRECAUTIONS WHEN REMOVING AND INSTALLING	6-2
PRECAUTIONS FOR USING	6-3
HANDLE BUCKET WITH HOOK.....	6-4
PRECAUTIONS FOR OPERATION	6-4
HANDLE MACHINE READY FOR INSTALLATION OF ATTACHMENT	6-5
EXPLANATION OF COMPONENTS ON MACHINES WITH ATTACHMENT	6-5
METHOD FOR CHANGING OVER AND CONNECTING HYDRAULIC CIRCUIT OF MACHINES READY FOR INSTALLATION OF ATTACHMENT	6-9
METHOD FOR OPERATING ATTACHMENT.....	6-12
LONG-TERM STORAGE	6-18
SPECIFICATIONS	6-18
OTHER TROUBLE.....	6-18
BATTERY DISCONNECT SWITCH	6-19
SYSTEM OPERATING LAMP.....	6-21
HANDLE HEATER.....	6-22
EXPLANATION OF HEATER COMPONENTS.....	6-22
METHOD FOR USING HEATER.....	6-23
HANDLE RADIO.....	6-24
EXPLANATION OF RADIO EQUIPMENT	6-24
METHOD FOR CONTROLLING RADIO	6-27
STOW ANTENNA.....	6-29
CONTROL PATTERNS OTHER THAN STANDARD CONTROL METHOD (FOR MACHINES EQUIPPED WITH OPERATION PATTERN CHANGE-OVER VALVE)	6-30
METHOD FOR CHANGING CONTROL PATTERNS	6-31

ATTACHMENTS AND OPTIONS	6-33
INSTALL ATTACHMENT	6-33
RECOMMENDED ATTACHMENT OPERATIONS	6-34
HYDRAULIC BREAKER	6-34
BREAKERS	6-39
REPLACEMENT PARTS	7-1
PERIODIC REPLACEMENT OF DEFINED LIFE PARTS	7-2
DEFINED LIFE PARTS LIST	7-2
CONSUMABLE PARTS	7-3
CONSUMABLE PARTS LIST	7-3
RECOMMENDED FUEL, COOLANT, AND LUBRICANT	7-4
LUBRICATION CHART	7-5
METHOD FOR USING FUEL, COOLANT AND LUBRICANTS ACCORDING TO AMBIENT TEMPERATURE	7-7
RECOMMENDED BRANDS AND QUALITIES OTHER THAN KOMATSU GENUINE OILS	7-8
INDEX	8-1

SAFETY

WARNING

Please read and make sure that you fully understand the precautions described in this manual and the safety labels on the machine. When operating or servicing the machine, always follow these precautions strictly.

SAFETY LABELS

WARNING

Be sure that you fully understand the correct position, content and how to avoid a danger shown in the safety labels.

Handle the warning signs and safety labels used on this machine as follows.

- Always keep the safety labels clean so that you can read it properly. When cleaning the safety labels, do not use organic solvents or gasoline. These may cause the labels to peel off.
- If the safety labels are damaged, lost, or cannot be read properly, replace them with new ones. For details of the part numbers for the safety labels, see this manual or the actual label, and place an order to your Komatsu distributor.
- There are also other labels in addition to the warning signs and safety labels. Handle those labels in the same way.

LOCATION OF SAFETY LABELS

LOCATION OF SAFETY LABELS: CANOPY SPEC

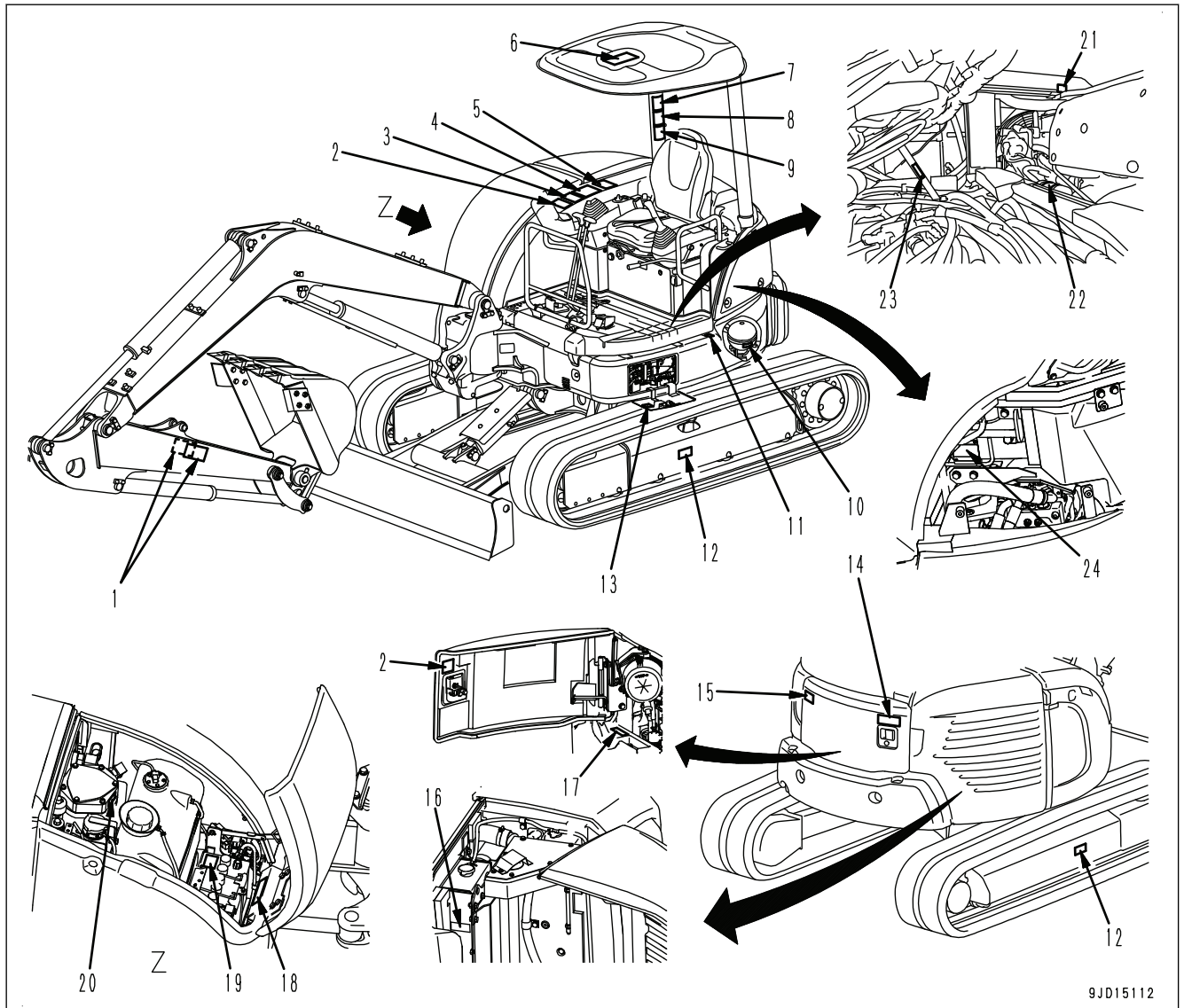

9JD15112

- | | |
|---|--|
| (1) Caution for work equipment | (13) Caution when changing control pattern |
| (2) Caution for operation, inspection and maintenance | (14) Prohibition of entering into swing range |
| (3) Caution when leaving operator's seat | (15) Stop rotation during inspection and maintenance |
| (4) Caution for electric cables | (16) Caution for high-temperature coolant |
| (5) Caution for control pattern | (17) Caution for high-pressure fuel |
| (6) Caution for handling ROPS | (18) Caution for handling cable |
| (7) Caution for blast site (machine with KOMTRAX) | (19) Caution for handling battery |
| (8) Caution before operating | (20) Caution for high-temperature hydraulic oil |
| (9) Caution for using seat belt | (21) Caution when closing floor |
| (10) Caution for handling accumulator | (22) Prohibition of start by short-circuiting |
| (11) Caution when opening floor | (23) Caution for handling gas spring |
| (12) Caution for adjusting track tension | (24) Caution against high temperature |

LOCATION OF SAFETY LABELS: CAB SPEC

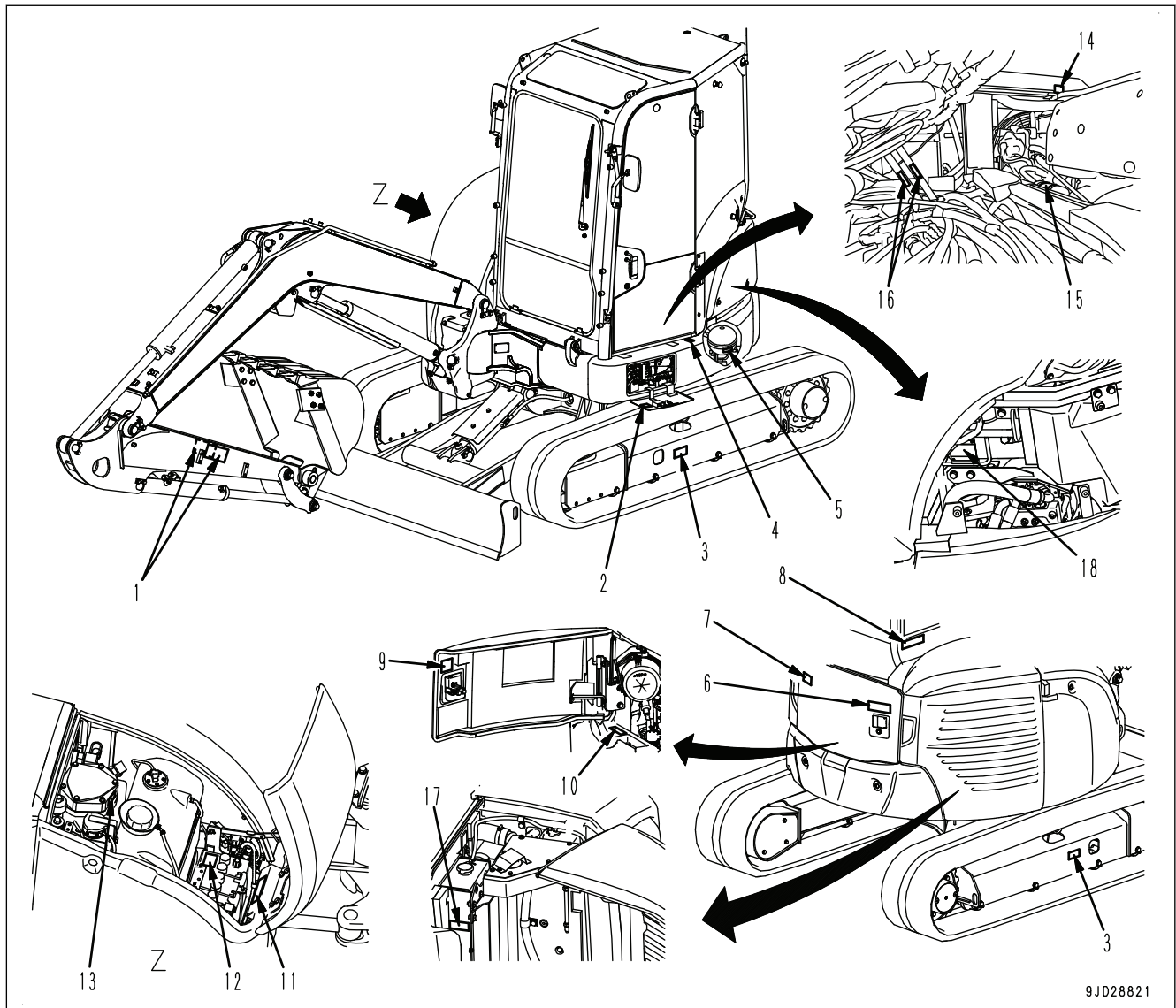

9JD28821

- | | |
|---|---|
| (1) Caution for work equipment | (10) Caution for high-pressure fuel |
| (2) Caution when changing control pattern | (11) Caution for handling cable |
| (3) Caution for adjusting track tension | (12) Caution for handling battery |
| (4) Caution when opening floor | (13) Caution for high-temperature hydraulic oil |
| (5) Caution for handling accumulator | (14) Caution when closing floor |
| (6) Prohibition of entering into swing range | (15) Prohibition of start by short-circuiting |
| (7) Stop rotation during inspection and maintenance | (16) Caution for handling gas spring |
| (8) Caution for handling ROPS | (17) Caution for high-temperature coolant |
| (9) Caution for operation, inspection and maintenance | (18) Caution against high temperature |

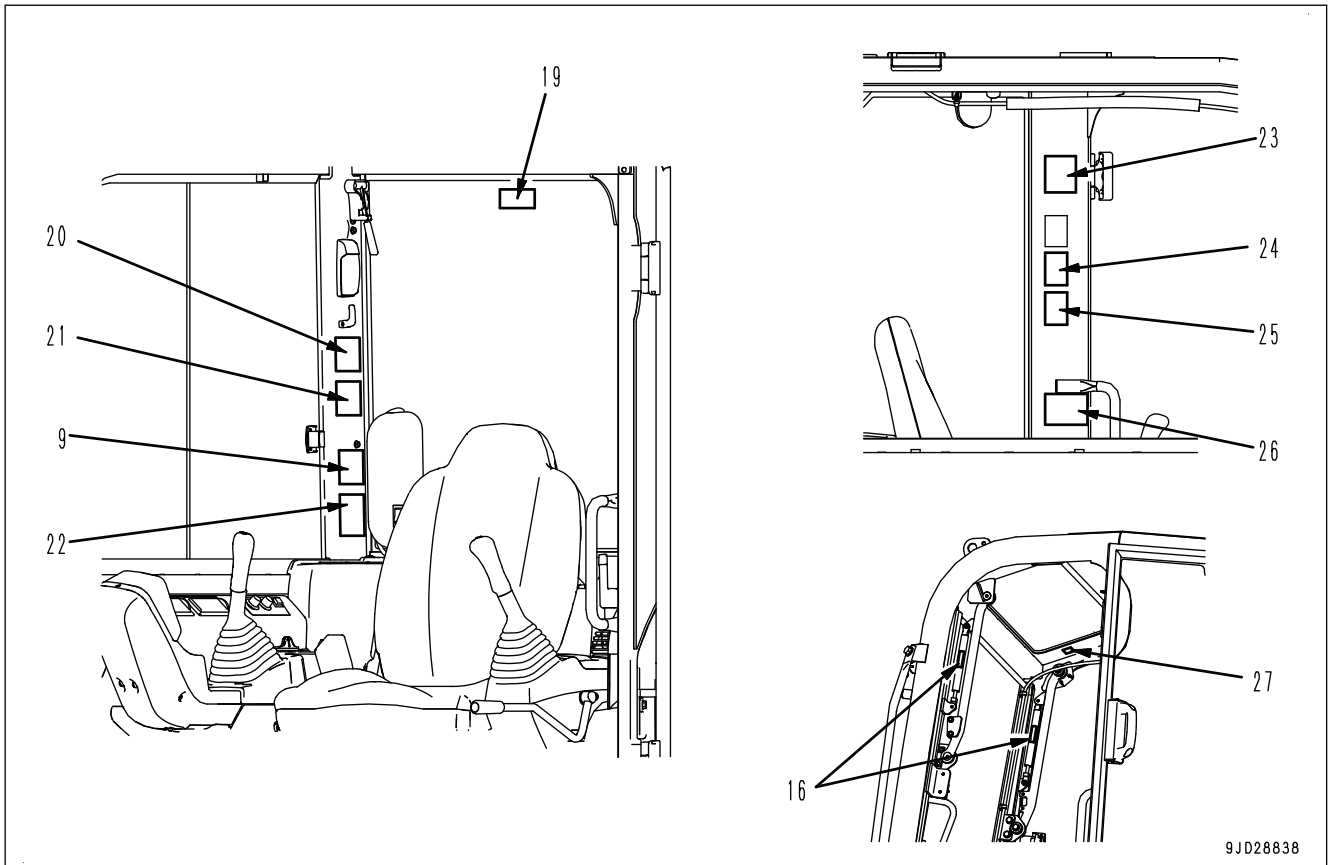

- (9) Caution for operation, inspection and maintenance
- (16) Caution for handling gas spring
- (19) Emergency escape
- (20) Caution for blast site (machine with KOMTRAX)
- (21) Caution for using seat belt
- (22) Caution when leaving operator's seat

- (23) Caution before operating
- (24) Caution for control pattern
- (25) Caution for electric cables
- (26) Caution when opening or closing front window
- (27) Caution when stowing front window

CONTENTS OF SAFETY LABELS

Caution for operation, inspection and maintenance

“09651-03001”

 WARNING
<p>Improper operation and maintenance can cause serious injury or death.</p> <p>Read manual and labels before operation and maintenance. Follow instructions and warnings in manual and in labels on machine.</p> <p>Keep manual in machine cab near operator. Contact Komatsu distributor for a replacement manual.</p>
<small>09651-03001</small>

Caution before operating

“22L-98-22160”

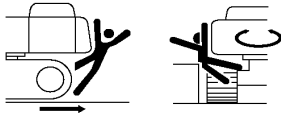
 WARNING

<p>To prevent SEVERE INJURY or DEATH. Do the following before moving machine or its attachments:</p> <ul style="list-style-type: none"> • Honk horn to alert people nearby. • Be sure no one is on or near machine or in swing area. • Rotate cab for full view of travel path if it can be done safely. • Use spotter if view is obstructed. <p>Follow above even if machine equipped with travel alarm and mirrors.</p>
<small>22L-98-22160</small>

Caution for using seat belt

“09848-03000”

 WARNING
<p>Always use seat belt when operating the machine to reduce risk of injury or death in case of a roll-over.</p> <p>Always check for damage or wear of the seat belt, damage of the connecting brackets, and tightness of bolts.</p> <p>Adjust seat position to allow full travel of the pedals with the operator's back against seat back.</p> <p>After adjusting seat position, get off the seat and tighten the tether belts located between the floor and seat if equipped.</p> <p>Read Operation and Maintenance Manual.</p>
<small>09848-03000</small>

Caution when leaving operator's seat

"09654-03001"

⚠ WARNING

To avoid hitting unlocked equipment levers, lower attachment to ground and move equipment lock lever to LOCK position before standing up from operator's seat.
Read Operation and Maintenance Manual.

Sudden and unwanted machine movement can cause serious injury or death.

09654-03001

Caution for electric cables

"09801-03002"

⚠ DANGER

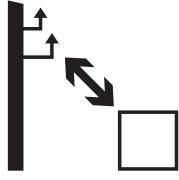
Electrocution Hazard

Serious injury or death will occur if machine or attachments are not kept away from electric lines.
Maintain a minimum clearance in accordance with this chart.

VOLTAGE	MIN. DISTANCE
50 kV or Less	3.1 m (10 ft)
50 kV to 200 kV	4.6 m (15 ft)
200 kV to 350 kV	6.1 m (20 ft)
350 kV to 500 kV	7.7 m (25 ft)
500 kV to 750 kV	10.7 m (35 ft)
750 kV to 1,000 kV	13.8 m (45 ft)

09801-03002

Caution for control pattern

"22N-98-51251"

 WARNING
<p>THIS MACHINE IS EQUIPPED WITH A CONTROL PATTERN SELECTOR VALVE.</p> <p>TO PREVENT PERSONAL INJURY CAUSED BY MISTAKEN OPERATION ALWAYS CHECK THAT THE MOVEMENT OF THE MACHINE MATCHES THE PATTERN SHOWN ON THE CONTROL PATTERN CARD WHEN OPERATING MACHINES.</p> <ul style="list-style-type: none"> • WHEN CHECKING THE MOVEMENT OF THE MACHINE, CHECK THAT THE SURROUNDING AREA IS SAFE AND OPERATE THE MACHINE SLOWLY. • IF THE MOVEMENT DOES NOT MATCH THE CONTROL PATTERN CARD, REPLACE THE CARD WITH THE CARD SHOWING THE CORRECT CONTROL PATTERN. <p>ALWAYS DO AS FOLLOWS WHEN CHANGING THE CONTROL PATTERN.</p> <ul style="list-style-type: none"> • LOWER THE WORK EQUIPMENT TO THE GROUND, STOP TO THE ENGINE, AND SET THE LOCK LEVER TO THE LOCK POSITION. THEN CHANGE THE CONTROL PATTERN.
22N-98-51251

Caution for high-temperature coolant

"20M-98-83250"

 WARNING
<p>Hot water hazard.</p> <p>To prevent hot water from spurting out:</p> <ul style="list-style-type: none"> • Turn engine off. • Allow water to cool. • Slowly loosen cap to relieve pressure before removing.
20M-98-83250

Caution for high-temperature hydraulic oil

"22L-98-22240"

 WARNING
<p>Hot oil hazard. To prevent hot oil from spurting out:</p> <ul style="list-style-type: none"> • Turn engine off. • Allow oil to cool. • Slowly loosen cap to relieve pressure before removing.
22L-98-22240

Caution against high temperature

"09817-A0753"

- Sign indicates a burn hazard from touching heated parts, such as engine, motor, or muffler during or right after operation.
- Never touch when hot.



Caution for handling cable

"09808-03001"

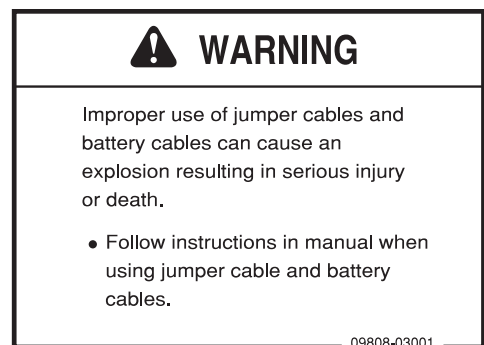

Caution for adjusting track tension

"09657-03003"

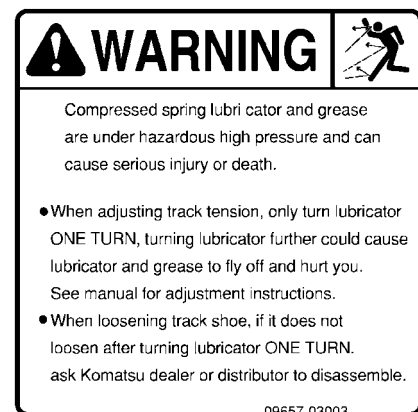

Stop rotation during inspection and maintenance

"09667-03001"

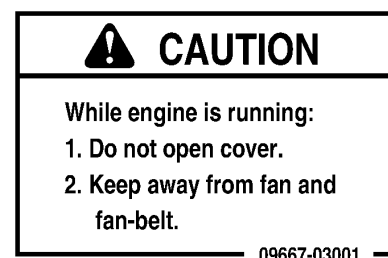

Prohibition of entering into swing range

"22N-98-51210"



Caution for work equipment

“09134-A0881”

- Sign indicates a hazard of being hit by the work equipment of the machine.
- Keep away from machine during operation.



Caution when opening or closing front window

(Machine with cab specification)

“09839-03001”

	WARNING
<p>Accidental contact with control levers may cause unintended machine movement resulting in injury or death, Always lower attachments to ground, set lock lever to LOCK position and stop engine before:</p> <ul style="list-style-type: none"> • opening or closing front window, ceiling window or door • attaching or detaching bottom window • adjusting seat position • standing up, etc. 	
09839-03001	

Caution when stowing front window

(Machine with cab specification)

“09803-03000”

	WARNING
<p>When raising window, lock it in place with lock pins on both sides.</p> <p>Falling window can cause injury.</p>	
09803-03000	

Caution when changing control pattern

“22L-98-22311”

⚠ WARNING

- WHEN CHANGING THE CONTROL PATTERN, SET THE MACHINE IN THE PARKING CONDITION, STOP THE ENGINE, AND SET THE LOCK LEVER TO THE LOCK POSITION.
- ALIGN THE CONTROL PATTERN SELECTOR LEVER TO THE SPECIFIED POSITION. (CHECK THE DETENT.)
- AFTER CHANGING THE CONTROL PATTERN, DO NOT FORGET TO EXCHANGE THE CONTROL PATTERN CARD AND DISPLAY THE NEW CONTROL PATTERN CARD INSIDE THE OPERATOR'S CAB.
- DO NOT RISK SERIOUS BODILY INJURY OR DEATH.

22L-98-22311

Caution when opening floor

“22L-98-22390”

⚠ DANGER INSERT A LOCK PIN TO KEEP TILTED FLOOR IN A SAFE PLACE.

22L-98-22390

Caution when closing floor

“22L-98-22410”

⚠ CAUTION

**WHEN YOU DOWN THE FLOOR,
DO NOT INSERT HAND AND
FOOT UNDER THE FLOOR.**

22L-98-22410

Caution for handling battery

“09664-30014”

⚠ DANGER

DANGER: Lead Acid Battery. Contains Lead, Sulfuric Acid and Lead Compounds.
WARNING: Risk of explosion, burn or fire. Do not disassemble.
 High Voltage : Risk of shock, do not touch uninsulated terminals or connectors.
 KEEP OUT OF REACH OF CHILDREN. KEEP VENT CAPS TIGHT AND LEVEL.

Open flames or sparks could cause battery to explode. May form explosive air/gas mixture during charging. Store and use in well-ventilated area.
 Extremely flammable gas (hydrogen). Explosion, Fire, Blast or Projectile hazard. Do not handle or charge until all safety precautions/instructions have been read and understood. Wear protective gloves, protective clothing, eye protection and face protection when handling. If SWALLOWED, INHALED, or IN EYE: immediately call a POISON CENTER or consult doctor/physician. If on CLOTHES or SKIN: wash immediately with water.

Komatsu America Corp. 1701 Golf Rd. Rolling Meadows, IL 60008, (731)635 6321 09664-30014

Caution for handling ROPS

“22N-98-51750”

ROPS / OPG TOP GUARD CERTIFICATION

This protective structure complies with the standard provided that it is properly equipped on the machine which mass is less than the specified maximum mass.

KOMATSU

ROPS : ISO 3471:2008, SAE J1503 MAY03 OPG : ISO 10262:1988

MODEL [] MACHINE MODEL [] OPG LEVEL No. []

SERIAL No. [] MAX. MASS [] kg (lb)

⚠ WARNING

- If any modification is applied to the ROPS or OPG, it may affect the strength and may not comply with the standard.
- Do not drill, cut or weld on the ROPS or OPG structure. Any modification is Prohibited
- ROPS or OPG may provide less protection if it has been structurally damaged or involved roll-over. Consult Komatsu Distributor in that case.
- Always wear seat belt when moving.

Komatsu Ltd. 2-3-6 Akasaka, Minato-ku, Tokyo, Japan 22N-98-51750

Caution for handling accumulator

“09659-53000”

⚠ WARNING

Explosion hazard:

- Do not disassemble
- Do not weld, drill, or hit
- Keep away from flame

09659-53000

Caution for handling gas spring

“09659-53000”

⚠ WARNING

Explosion hazard:

- Do not disassemble
- Do not weld, drill, or hit
- Keep away from flame

09659-53000

Emergency escape

(Machine with cab specification)

“09844-00050”

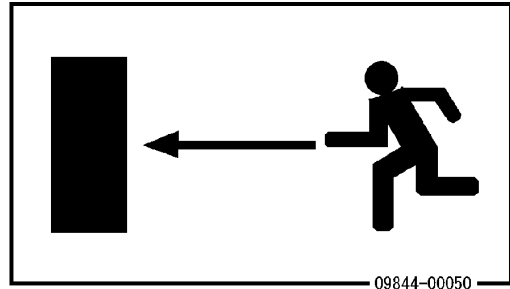

Caution for blast site

(Machine with KOMTRAX)

“09845-13000”



Caution for high-pressure fuel

“22N-98-51860”

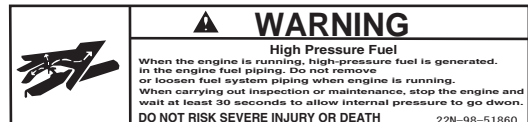

Prohibition of start by short-circuiting

“09842-A0642”

- Start the engine only while sitting on the operator’s seat.
- Do not attempt to start the engine by short-circuiting the engine starting circuit. Such an act may cause a serious personal injury or fire.



GENERAL PRECAUTIONS COMMON TO OPERATION AND MAINTENANCE

Mistakes in operation, inspection, or maintenance may result in serious personal injury or death. Before performing operation, inspection, or maintenance, always read this manual and the safety labels on the machine carefully and obey the warnings.

PRECAUTIONS BEFORE STARTING OPERATION

ENSURE SAFE OPERATION

- Only trained and authorized personnel can operate and maintain the machine.
- Follow all safety, precautions, and instructions in this manual when operating or performing inspection or maintenance on the machine.
- If you are not feeling well, or if you are under the influence of alcohol or medication, your ability to safely operate or repair your machine may be severely impaired, putting yourself and everyone else on your job site in danger.
- When working with another operator or with the person on the worksite traffic duty, discuss the content of the operation beforehand and use the determined signals when performing the operation.

UNDERSTAND THE MACHINE

Before operating the machine, read this manual thoroughly. If there is any place in this manual that you do not understand, ask the person in charge of safety for explanation.

PREPARATIONS FOR SAFE OPERATION

PRECAUTIONS FOR SAFETY-RELATED EQUIPMENT

- Be sure that all the protective guards, covers, and mirrors are installed properly. If any of them are broken, replace it immediately.
- Understand the using method of the safety related devices and use them properly.
- Never remove any safety related devices. Always keep them in good operating condition.

INSPECT MACHINE

Check the machine before starting operations. If any abnormality is found, do not operate the machine until repairs of the problem location have been completed.

WEAR WELL-FITTING CLOTHES AND PROTECTIVE EQUIPMENT

- Do not wear loose clothes or any accessories. If any of these catch the control levers or protruding parts, it may cause the machine to move unexpectedly, it is extremely dangerous.
- Always wear a hard hat and safety shoes. Wear protective eyeglasses, mask, gloves, ear plugs, and safety belt as appropriate for the work function.
- Long hair hanging out from the hard hat is dangerous that it may get caught up in the machine. Tie the hair up and be careful not to be caught.
- Check that all personal protective items function properly before using them.

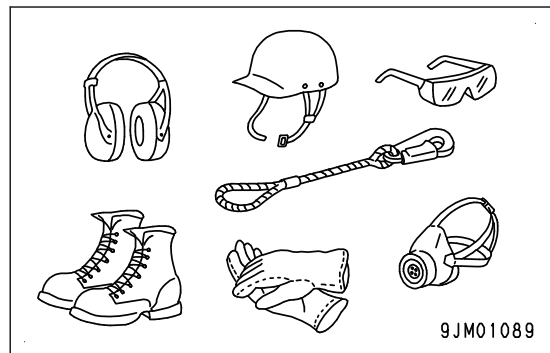

KEEP MACHINE CLEAN

- If you get on or off the machine or perform inspection and maintenance on the machine with mud or oil, you may slip and fall, and it is dangerous. Wipe off any mud or oil from the machine. Always keep the machine clean.
- If water gets into the electrical system, electric devices will cause malfunctions, and the machine will cause error. If the machine cause error, it may move unexpectedly and cause serious personal injury or death. When washing the machine with water or steam, do not allow the water or steam to come into direct contact with electrical components.
- Cover the electric system with vinyl cover when washing the machine with floor opened (the cab is tilted), so that it does not get wet.

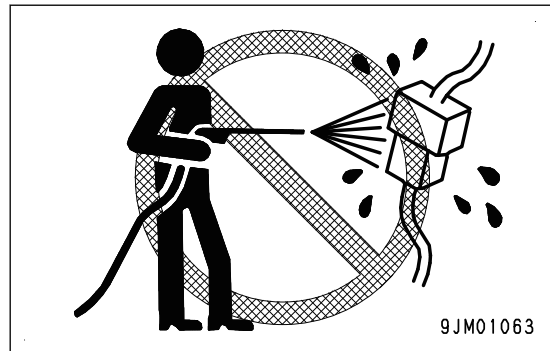

PRECAUTIONS FOR INSIDE OPERATOR'S COMPARTMENT

- When entering the operator's compartment, always remove all mud and oil from the soles of your shoes. If you operate the pedal with mud or oil affixed to your shoes, your foot may slip and this may cause a serious accident.
- Do not leave tools or machine parts lying around inside the operator's compartment. If tools or parts get into the control devices, it may obstruct operation and cause the machine to move unexpectedly, resulting in serious personal injury or death.
- Do not stick suction pads to the window glass. Suction pads act as a lens and may cause fire.
- Do not use a cellular phone when driving or operating the machine. This may lead to mistakes in operation, and may cause serious personal injury or death.
- Never bring any dangerous objects such as flammable or explosive items into the operator's compartment.

PROVIDE FIRE EXTINGUISHER AND FIRST AID KIT

Observe the following precautions to prepare for action if any serious personal injury or death or fire should occur.

- Be sure that fire extinguishers have been provided and read the labels to ensure that you know how to use them for the possibility of fires.
- Perform periodic inspection and maintenance to ensure that the fire extinguisher can always be used.
- Provide a first aid kit in the storage point. Perform periodic checks and add to the contents if necessary.

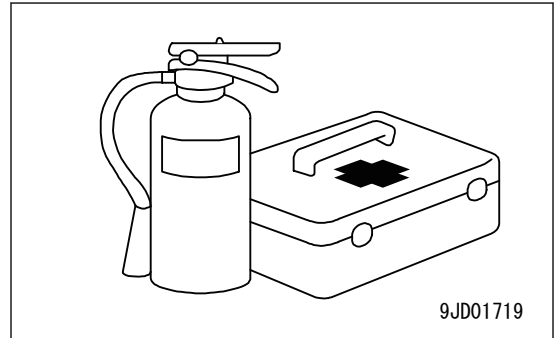
**IF ANY PROBLEM IS FOUND**

If you find any problem in the machine during operation or maintenance (noise, vibration, smell, incorrect gauges, smoke, oil leakage, etc., or any abnormal display on the warning devices or monitor), report to the person in charge and take the necessary action. Do not operate the machine until the problem has been corrected.

PRECAUTIONS TO PREVENT FIRE

ACTIONS IF FIRE OCCURS

- Turn the starting switch to OFF position, and stop the engine.
- Escape from the cab by using handrail and track.
- Do not jump off the machine. There is the danger of falling and it may cause personal injury.
- The fume generated by a fire contains harmful materials which have a bad influence on your body when they are inhaled.
Do not breathe the fumes.
- After a fire, harmful compounds may be left. If it touches your skin, it may have a bad influence on your body.
Be sure to wear rubber gloves when handle the materials left after the fire.
The material of the gloves, which is recommended is polychloroprene (Neoprene) or polyvinyl chloride (in the lower temperature environment).
When wearing cotton work gloves, wear rubber gloves under them.

PREVENT FIRE

Fire caused by fuel, oil, coolant, or window washer fluid

Do not bring any open flame close to flammable substances such as fuel, oil, coolant, or window washer fluid. There is a danger that they may catch fire. Always observe the following.

- Do not smoke or use any flame near fuel or other flammable substances.
- Shut down the engine before adding fuel.
- Do not leave the machine when adding fuel or oil.
- Tighten all the fuel and oil caps securely.
- Be careful not to spill fuel on overheated surfaces or on parts of the electrical system.
- After adding fuel or oil, wipe up any spilled fuel or oil.
- Put the greasy rags and other combustible materials into a safe container to maintain safety at the workplace.
- When washing the parts with oil, use a non-flammable oil. Do not use the diesel fuel or gasoline. There is danger that they may catch fire.
- Do not weld or use a cutting torch to cut any pipes or tubes that contain combustible liquids.
- Determine the well-ventilated areas for storing oil and fuel. Keep the oil and fuel in the specified place and do not allow unauthorized persons to enter.
- When performing the machine grinding or welding work, move any flammable materials to a safe place before starting.

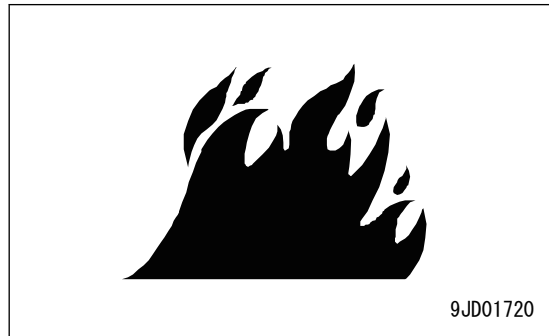

Fire caused by accumulation of combustible material

Remove any dry leaves, chips, pieces of paper, coal dust, or any other combustible materials accumulated or affixed around the engine exhaust manifold, muffler, or battery, or inside the undercovers.

Fire coming from electric wiring

Short circuits in the electrical system can cause fire. Always observe the following.

- Keep all the electric wiring connections clean and securely tightened.
- Check the wiring every day for looseness or damage. Reconnect any loose connectors or refasten the wiring clamps. Repair or replace any damaged wiring.

Fire caused from piping

Check that all the hose and tube clamps, guards, and cushions are securely fixed in position.

If they are loose, they may vibrate during operation and rub against other parts. This may lead to damage the hoses and cause the high-pressure oil to spurt out, leading to fire and personal injury.

Fire around the machine due to highly heated exhaust gas

This machine is equipped with Komatsu Diesel Particulate Filter (hereafter KDPF).

KDPF is a device to purify the soot in the exhaust gas. Exhaust gas temperature may increase during the purification process (regeneration). Do not bring any combustible material close to the outlet of the exhaust pipe.

When there are thatched houses, dry leaves or pieces of paper near the job site, stop the aftertreatment devices regeneration to prevent fire hazards due to highly heated exhaust gas during the aftertreatment devices regeneration.

Take appropriate actions to prevent fire.

Explosion caused by lighting equipment

When checking fuel, oil, battery electrolyte, or coolant, always use the lighting with anti-explosion specifications.

PRECAUTIONS WHEN GETTING ON OR OFF MACHINE

USE HANDRAILS AND STEP ON TRACK WHEN GETTING ON OR OFF MACHINE

To prevent personal injury caused by slipping or falling off the machine, always observe the following.

- The handrail and track shown with arrows in the figure can be used for getting on and off.
 - Machine with canopy specification

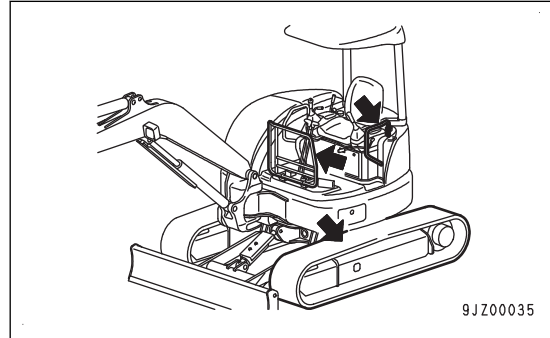

- Machine with cab specification

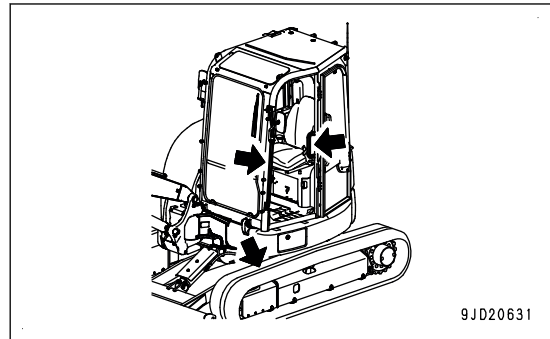

- Always follow the three-point rule for safety. The three-point rule means three of your four limbs are in contact with the handrail and track at all times (two hands and one foot or two feet and one hand).
- Before getting on and off the machine, check the handrails and tracks if there is any oil, grease, or mud on them. Wipe it off immediately not to slip if any. If there is any loose bolt on the handrails, tighten it securely. If the handrails are damaged or deformed, they need to be repaired immediately. Ask your Komatsu distributor for that work.

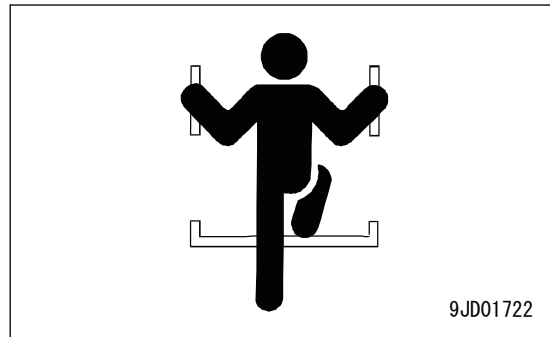

- Do not grip the control levers or lock lever when getting on or off the machine. At that time, take care that your body or clothes do not touch the levers.
- Never climb on the engine hood or covers where there are no non-slip pads.
- Do not get on or off the machine with tools in your hand.

NO JUMPING ON OR OFF MACHINE

Getting on or off the moving machine can cause serious personal injury or death. Always observe the following.

- Never jump on or off the machine. Never get on or off a moving machine.
- If the machine starts to move when there is no operator on the machine, do not jump on to the machine and try to stop it.

NO PEOPLE ON ATTACHMENTS

Never let anyone ride on the work equipment or other attachments. There is a hazard of falling and suffering serious personal injury or death.

PRECAUTIONS WHEN STANDING UP FROM OPERATOR'S SEAT

Before standing up from the operator's seat in order to open or close the front window or to adjust the operator's seat, be sure to lower the work equipment and blade to the ground, grip the operating portion on top of the lock lever (1) to set the lock lever (1) to LOCK position (L), and stop the engine.

If the control levers are touched by mistake, there is danger that the machine may suddenly move and cause serious personal injury or death.

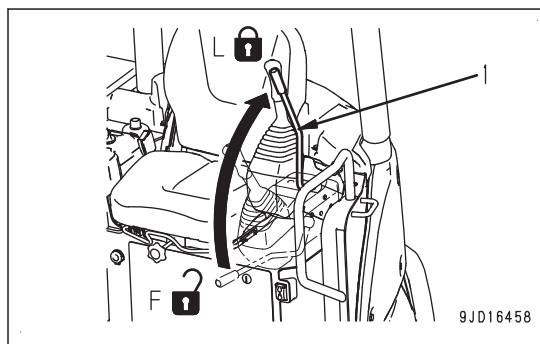

PRECAUTIONS WHEN LEAVING MACHINE

If the proper procedures are not taken when parking the machine, the machine may suddenly move off by itself, and this may lead to serious personal injury or death. Observe the following.

- When leaving the machine, be sure to make the undercarriage and upper structure point to the same direction, lower the work equipment and blade to the ground, grip the operating portion on top of the lock lever (1) to set the lock lever (1) to LOCK position (L), and stop the engine.
- If the seat is positioned forward, your body or clothes will easily touch the levers. Shift the seat backward to keep enough space, and then get off the machine.
- Lock all the places and always take the key with you and keep it in the specified place.

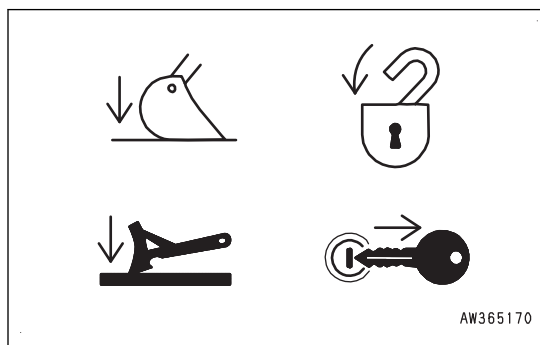
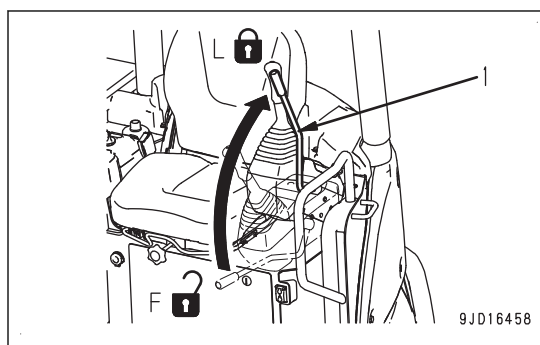

EMERGENCY EXIT FROM OPERATOR'S CAB

- If it should be impossible to open the door of the cab, break the window glass with the hammer supplied and use the window as an emergency escape.
- When escaping, remove the pieces of glass from the window frame first and be careful not to cut yourself on the glass. Be careful also not to slip on the broken pieces of glass on the ground.

DO NOT GET CAUGHT IN WORK EQUIPMENT

The clearance in the area around the work equipment changes according to the movement of the link. If you are caught, this may lead to serious personal injury or death. Do not allow anyone near any of the rotating or telescopic parts.

PRECAUTIONS RELATED TO PROTECTIVE STRUCTURES

The operator's compartment is equipped with a structure (such as ROPS, OPG) to protect the operator by absorbing the impact energy.

As for the machine equipped with ROPS, if the machine weight (mass) exceeds the certified value (shown on ROLL-OVER PROTECTIVE STRUCTURE (ROPS) CERTIFICATION plate), ROPS will not be able to fulfill its function. Do not increase machine weight beyond the certified value by modifying the machine or by installing attachments to the machine.

Also, if the function of the protective equipment is impeded, the protective equipment will not be able to protect the operator, and the operator may suffer injury. Always observe the following.

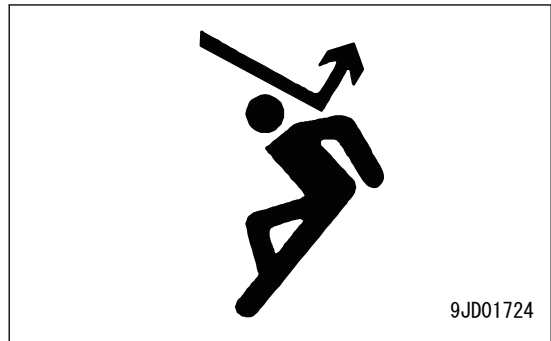

- If the machine is equipped with a protective structure, do not remove the protective structure and perform operations without it.
- If the protective structure is welded, or holes are drilled in it, or it is modified in any other way, its strength may drop. Any modification is prohibited.
- If the protective structure is damaged or deformed by falling objects or by rolling over, its strength will be reduced and it will not be able to fulfill its function properly. In such cases, always consult your Komatsu distributor
- Even if the protective structure is installed, always fasten your seat belt properly when operating the machine. If you do not fasten your seatbelt properly, it cannot display its effect. Always fasten your seat belt while operating the machine.

Prohibition of removing ROPS canopy

- Never detach the ROPS canopy. If the machine tipped over without the canopy, it may lead to serious personal injury or death.
- When removing and installing the canopy for transportation, ask your Komatsu distributor to perform this work beforehand.

PROTECTION AGAINST FALLING, FLYING OR INTRUDING OBJECTS

On jobsite where there is a danger of falling objects, scattering fragments, and things which may intrude into operator's cab, install the necessary equipment to protect the operator depending on the working conditions.

- When operating the work in the site such as a mine or a quarry where rocks may fall on, have falling object protective structure (FOPS) and the front guard installed, and have the front glass laminated. In addition, always check that there is no one except the operator in the surrounding area where there is a danger of falling objects, scattering fragments.
- When operating the demolition work or the breaker operation, have the front guard installed, and have the front glass laminated. In addition, always check that there is no one except the operator in the surrounding area where there is a danger of falling objects, scattering fragments.

Above precautions are developed for the standard jobsite. Depending on the conditions of the jobsite, installation of additional guards is necessary.

Do not operate the machine without the necessary guards. Be sure to consult with your Komatsu distributor about necessary guards.

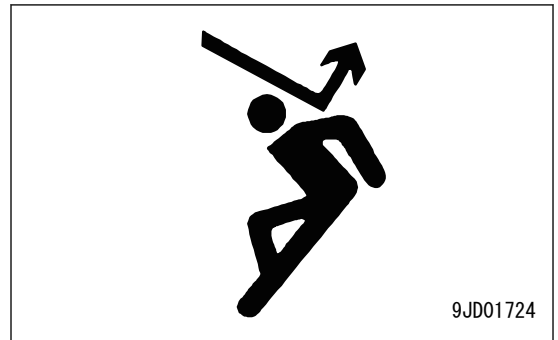
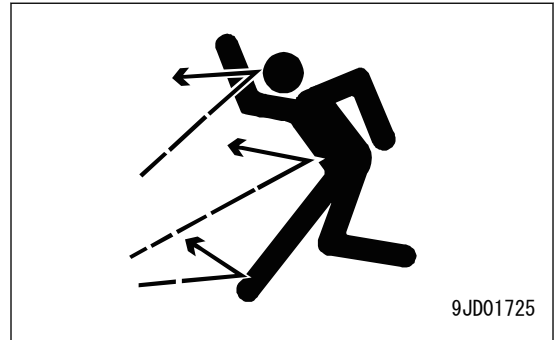

UNAUTHORIZED MODIFICATION

- Komatsu will not be responsible for any personal injuries, product failures, physical loss or damage, or influence on the environment resulting from modifications made without authorization from Komatsu.
- Any modification made without authorization from Komatsu can create hazards. Before making a modification, consult your Komatsu distributor.

PRECAUTIONS RELATED TO ATTACHMENTS AND OPTIONS

- Any personal injuries, product failures, physical loss or damage, or influence on the environment resulting from the use of unauthorized attachments or parts will not be the responsibility of Komatsu.
- When installing optional parts or attachments, contact your Komatsu distributor for advice to any potential problems or safety and legal requirements.
- The machine weight will not exceed ROPS certified value as long as the optional attachments written in the attachment combination table of this manual are installed. When installing optional parts or attachments which are not written in this manual, the machine weight must not exceed ROPS certified value. Always contact your Komatsu distributor before installing.
- Installing some work equipment combinations may cause interference and damage with the cab or other parts of the machine during operation and could cause serious personal injury or death. Before using unfamiliar work equipment, always check for potential interference while operating the machine. Always ensure the operator's safety when working with unfamiliar work equipment.
- When installing and using optional attachments, always read the instruction manual for the attachment, and the general information related to attachments in this manual.

PRECAUTIONS RELATED TO CAB GLASS

- If the cab glass is broken during operations, stop operations and repair the cab glass immediately.
- If the cab glass on the work equipment side is broken, there is a hazard that the operator may be directly hit or caught in the work equipment. If the glass is broken, stop operation immediately and replace the glass.

PRECAUTIONS WHEN RUNNING ENGINE INSIDE BUILDING

The engine exhaust gas contains substances that may damage your health or even cause death. Start or operate the engine in a place where there is good ventilation. If the engine or machine must be operated inside a building or underground, where the ventilation is poor, take steps to ensure that the engine exhaust gas is removed and that ample fresh air is brought in. When handling the fuel, cleaning oil, and paint, work in a well-ventilated area with windows and doors open.

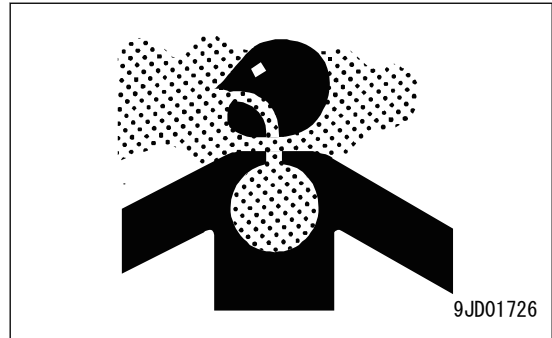

PRECAUTIONS FOR OPERATION

PRECAUTIONS FOR JOBSITE

INVESTIGATE AND CONFIRM JOBSITE CONDITIONS

On the jobsite, there are various hidden dangers that may lead to serious personal injury or death. Before starting operations, always check the following to confirm that there is no danger on the jobsite.

- Always be careful when performing operations near materials such as thatched roofs, dry leaves or dry grass, because they are easily combustible and may cause fire.
- Check the terrain and condition of the ground at the jobsite, and determine the safest method of operation. Do not operate in a dangerous area where landslides or rockfall may occur.
- If water lines, gas lines, or high-voltage electrical lines may be buried under the jobsite, contact the management company to identify their locations, and be careful not to damage any of these lines.
- Take necessary measures to prohibit other personnel from coming close to the machine during operation.
- In particular, if you need to operate on a road, protect pedestrian and cars by designating a person for jobsite traffic duty or by installing fences around the jobsite.
- When traveling or operating in shallow water or on soft ground, check the water depth, speed of the current, condition of bedrock, and shape of the ground beforehand. Always avoid any place that will obstruct travel.

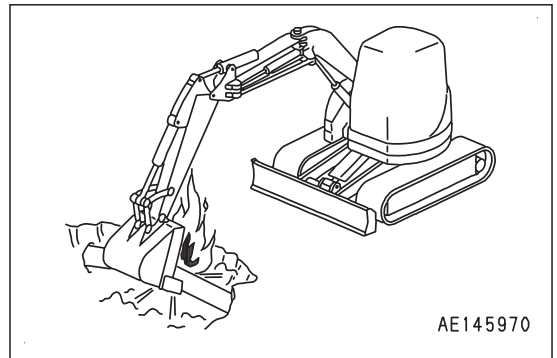

PRECAUTIONS WHEN WORKING ON LOOSE GROUND

- Avoid driving or operating the machine near the edge of cliffs, road edges, and deep ditches. The ground may be weak in such areas. If the ground should collapse under the weight or vibration of the machine, there is a hazard that the machine may fall or tip over. Remember that the soil is weak in these areas, after heavy rain or blasting or after earthquakes.
- When working on embankments or near excavated ditches, there is a hazard that the weight and vibration of the machine will cause the soil to collapse. Before starting operations, take steps to ensure that the ground is safe and to prevent the machine from rolling over or falling.

DO NOT GO CLOSE TO HIGH-VOLTAGE CABLES

Do not travel or operate the machine near electric cables. There is a hazard of electric shock, which may cause serious personal injury or death. On jobsites where the machine may go close to electric cables, always observe the following.

- Before starting work near electric cables, inform the local power company of the work to be performed, and ask them to take the necessary action.
- Even going close to high-voltage cables can cause electric shock. Always maintain a safe distance (see the table) between the machine and the electric cable. Check with the local power company about the voltage of cables and safe operating procedure before starting operations.

VOLTAGE	MIN. DISTANCE
50 kV or Less	3.1 m {10 ft}
50 kV to 200 kV	4.6 m {15 ft}
200 kV to 350 kV	6.1 m {20 ft}
350 kV to 500 kV	7.7 m {25 ft}
500 kV to 750 kV	10.7 m {35 ft}
750 kV to 1000 kV	13.8 m {45 ft}

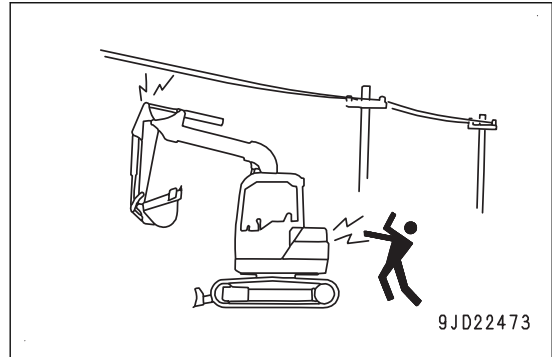

- To prepare for any possible emergencies, wear rubber shoes and gloves. Lay a rubber sheet on the operator's seat, and be careful not to touch the chassis with any exposed part of your body.
- Use a signalman to give warning if the machine approaches too close to the electric cables.
- When performing operations near high voltage cables, prohibit anyone other than related persons to come close to the machine during operation.
- If the machine should come too close or touch the electric cable, to prevent electric shock, the operator should not leave the operator's compartment until it has been confirmed that the electricity has been shut off. Also, prohibit any other persons to come close to the machine.

ENSURE GOOD VISIBILITY

Although this machine is equipped with mirrors, there are some areas out of sight from the operator's seat. Be careful when performing the operation.

When driving the machine or performing operations in places with poor visibility, it is dangerous and may cause serious personal injury or death because it is difficult to check for obstacles and condition of the jobsite. When driving the machine or performing operations in places with poor visibility, always observe the following.

- Allocate a signalman for jobsite duty if there are areas where the visibility is poor.
- Only one signalman should give signals.
- When working in dark places, turn on the working lamp and headlamps installed to the machine, and set up additional lighting in the work area if necessary.
- Stop operations if the visibility is poor because of mist, snow, rain, or dust.
- When checking the mirrors installed to the machine, remove all dirt and adjust the angle of the mirror to ensure good visibility.

CHECK SIGNS AND SIGNALMAN'S SIGNALS

If signals and labels are not clear, serious personal injury can result from downward slip, overturn or accidental contact with nearby people or obstacles. Always observe the following.

- Set up labels to inform of road edges and soft ground. If the visibility is not good, position a conductor if necessary. Operator should pay careful attention to the labels and follow the instructions from the conductor.
- Only one signalman should give signals.
- Make sure that all workers understand the meaning of all signals, signs, and labels before starting work.

BEWARE OF ASBESTOS DUST

Asbestos dust in the air can cause lung cancer if it is inhaled. There is danger of inhaling asbestos when working on jobsite where demolition work is performed or industrial waste is handled. Always observe the following.

- Spray water to keep down the dust.
- Do not use compressed air.
- If there is danger that there may be asbestos dust in the air, always operate the machine from an upwind position, and make sure that all workers operate on the upwind side.
- All workers should use anti-dust masks.
- Prohibit other personnel from coming close to the machine during operation.
- Always observe the regulations for jobsite and environmental standards.

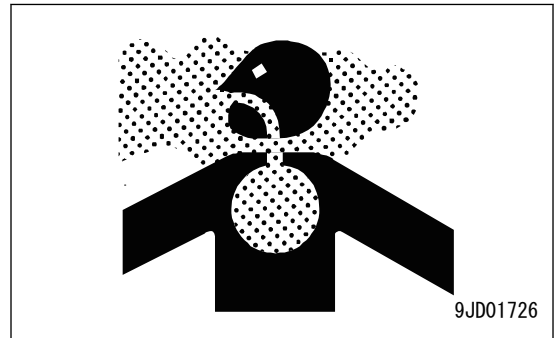

This machine does not contain asbestos, but any part which is not the genuine part, has risk of containing asbestos. Always use Komatsu genuine parts.

START ENGINE

USE WARNING TAGS

If there is a "DANGER! Do NOT operate!" warning tag displayed, it means that someone is performing inspection and maintenance of the machine. If the warning tag is ignored and the machine is operated, the person performing inspection or maintenance may be caught in the rotating parts or moving parts. It is dangerous and may cause serious personal injury or death. Do not start the engine or touch the levers.

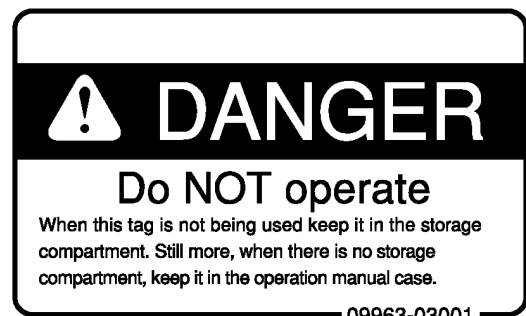
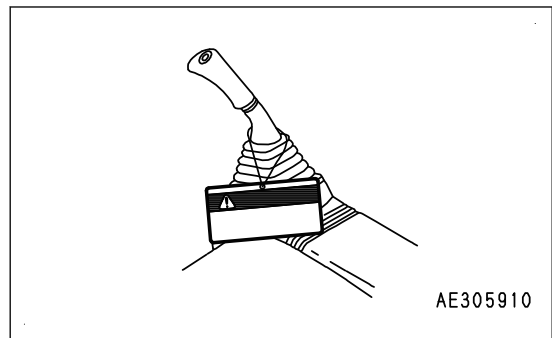

CHECKS AND ADJUSTMENT BEFORE STARTING ENGINE

Perform the following checks before starting the engine at the beginning of the day's work to ensure that there is no problem with the operation of the machine. If these checks are not performed properly, problems may occur with the operation of the machine, and there is a danger that may lead to serious personal injury or death.

- Remove all dirt from the surface of the window glass to ensure a good view.
- Be sure to perform thorough walk-around check.
- Remove all dirt from the surface of the lens of the headlamps and working lamps, and check that they light up correctly.
- Check the coolant level, fuel level, and oil level in engine oil pan, check for clogging of the air cleaner, and check for damage to the electric wiring.
- Check that there is no mud or dust accumulated around the movable parts of any pedals, and check that the pedals work properly.
- Adjust the operator's seat to a position where it is easy to perform operations, and check that there is no damage or wear to the seat belt or mounting clamps.
- Check that the gauges work properly, check the angle of the mirror, and check that the control levers are all at NEUTRAL position.
- Before starting the engine, check that lock lever (1) is in LOCK position (L).
- Adjust the mirrors so that the rear of the machine can be seen easily from the operator's seat.
- Check that there are no people or obstacles above, below, or in the area around the machine.
- Check that the floor is securely fixed with the floor tilt fixing bolts. If it is not securely fixed, it may lead to a serious personal injury or death.

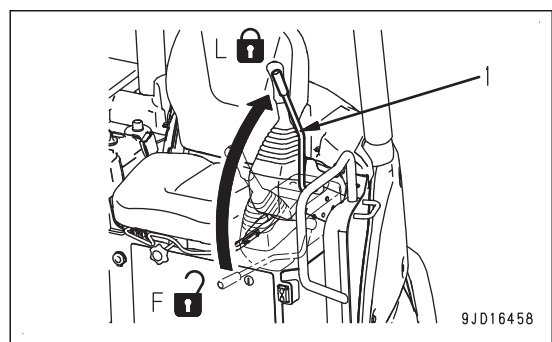

PRECAUTIONS WHEN STARTING ENGINE

The machine may suddenly move off and this may lead to serious personal injury or death. Always observe the following.

- Start the engine only while sitting down in the operator's seat.
- When starting the engine, sound the horn as a warning.
- Prohibit other personnel to get on the machine.
- Do not attempt to start the engine by short-circuiting the engine starting circuit. This may cause fire, serious personal injury or death.

IN COLD WEATHER

- If the warm-up operation is not performed thoroughly, and the work equipment is operated, the reaction of the work equipment to the operation of the control levers and pedals will be slow and the movement of it may not be what the operator intended. Be sure to perform the warm-up operation. Particularly in a cold weather, be sure the warming-up operation is completed.
- If the battery electrolyte is frozen, do not charge the battery or start the engine with a different power source. There is a hazard that this will ignite the battery and cause the battery to explode. Before charging or starting the engine with a different power source, melt the battery electrolyte and check that there is no leakage of electrolyte before starting.

START ENGINE WITH JUMPER CABLES

If any mistake is made in the method of connecting the jumper cables, it may cause the battery to explode, so always observe the following.

- Always wear protective eyeglasses and rubber gloves when starting the engine by using the jumper cables.
- When connecting a normal machine to a failed machine with the jumper cables, always use the normal machine with the same battery voltage as the failed machine.
- When starting the engine with the jumper cables, perform the starting operation with 2 workers (one worker sitting in the operator's seat and the other working with the battery).
- When starting from another machine, be careful that the normal machine does not contact with the failed machine.
- When connecting the jumper cables, turn the starting switch to OFF position for both the failed machine and the normal machine. If the failed machine has a battery disconnect switch, turn it to OFF position, and turn it ON again after connecting the cables. It is dangerous that the machine may move when the power is connected.
- Be sure to connect the positive (+) cable first when installing the jumper cables. Disconnect the negative (-) cable (ground side) first when removing them.
- When disconnecting the jumper cables, take care not to bring the clips in contact with each other or with the machine.

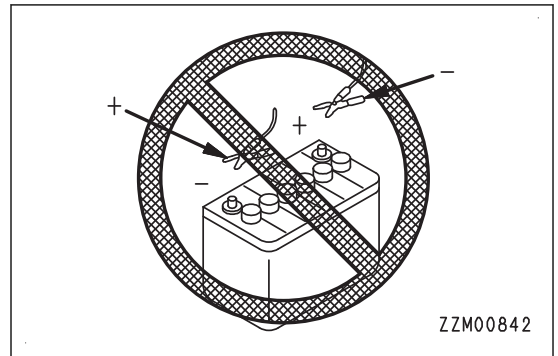

PRECAUTIONS FOR OPERATION

CHECKS BEFORE OPERATION

If the checks before starting are not performed properly, the machine will be unable to display its full performance. It is dangerous and may cause serious personal injury or death.

When performing the checks, move the machine to a wide area with no obstructions, and pay careful attention to the surroundings. Prohibit other personnel from coming close to the machine during checks.

- Fasten the seatbelt. When the brakes are applied suddenly, the operator may be thrown out of the operator's seat. It is dangerous and may cause personal injury.
- Check that the movement of the machine matches the display on the control pattern card.
If it does not match, replace it immediately with the correct control pattern card.
- Check the operating condition of the machine, work equipment, and travel and swing systems.
- Check for any problem in the sound, vibration, heat and smell of the machine, or abnormalities of instruments. Also check that there is no leakage of oil or fuel.
- If any problem is found, repair it immediately.

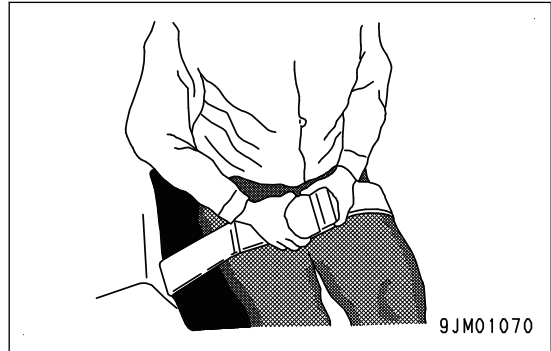

PRECAUTIONS WHEN TRAVELING IN FORWARD OR REVERSE AND SWINGING

- When driving the machine, drive with sprocket (1) at the rear of the machine. If sprocket (1) is at the front, the operation of the travel levers will be the opposite of the actual direction of travel, so there is a hazard that the machine may travel in an unexpected direction, leading to serious injury or death.
- Always lock all the doors and windows of the operator's compartment in position regardless of whether it is open or closed.
Always close all the windows and doors on jobsites where there is danger of scattering fragments, and things which may intrude into operator's cab.

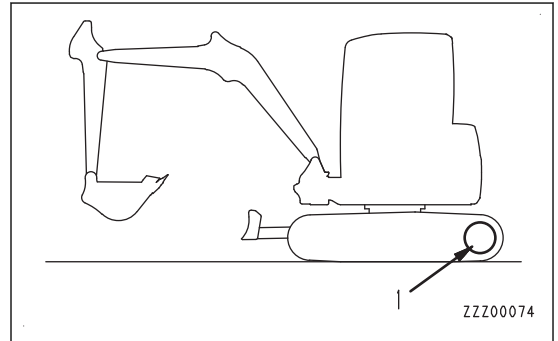

- Prohibit anyone other than the operator to get on the machine
- If there are any people in the area around the machine, there is danger that they may be hit or caught by the machine, and this may lead to serious personal injury or death. Before starting travel or swing, be sure to observe the following.
 - Always operate the machine only when seated on the operator's seat.
 - Before starting to move, check again that there is no people or obstacle in the surrounding area.
 - Before moving, sound the horn to warn people in the surrounding area.
 - Check that the travel alarm and other alarms work properly.
 - If there is an area in the rear of the machine which cannot be seen, position a signalman. Be extremely careful not to hit any people or object, and drive or swing slowly.

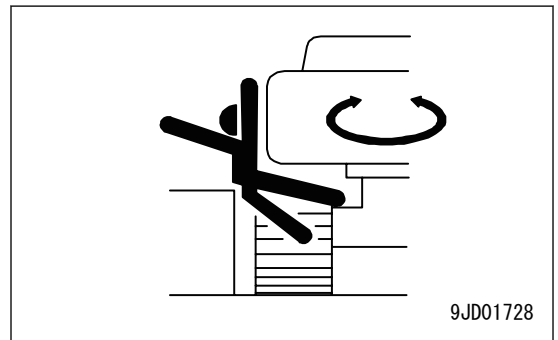
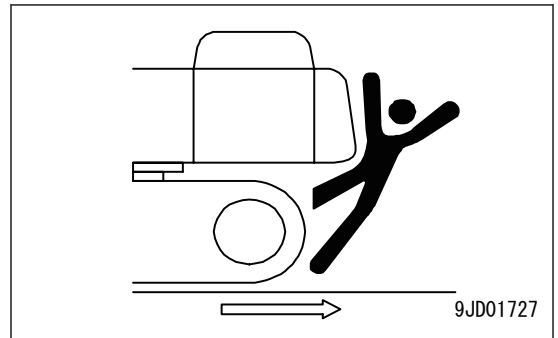

Observe the above mentioned precautions although the mirror is installed.

PRECAUTIONS WHEN TRAVELING

Serious personal injury or death can result from tipping over of the traveling machine or its accidental contact. Always observe the following.

- Do not drive the machine with excess speed, stop suddenly, and starts suddenly. It is quite dangerous.
- When driving the machine or performing operations, always keep a safe distance from people, structures, or other machines to avoid coming into contact with them.
- When driving the machine on a level ground, keep the work equipment at height (a) of 40 to 50 cm {15.7 to 19.7 in} above the ground. If that height is not maintained between the work equipment and the ground, the work equipment may get stuck in the ground and the machine may tip over.

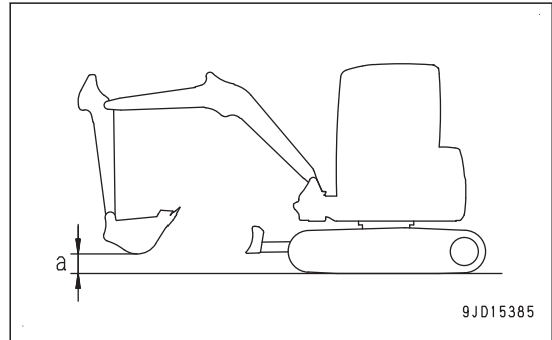

- Try to avoid traveling over obstacles. If the machine has to travel over an obstacle, keep the work equipment close to the ground and travel at low speed. The machine tips over easily to the right or left. Do not drive it over obstacles which make the machine tilt largely to the right or left.
- When driving the machine on the rough ground, drive it at low speed and do not operate the steering suddenly. There is a danger that the machine may tip over. The work equipment may hit the ground, and the machine may lose its balance, or it may damage the machine or structures in the area.
- When using the machine, to prevent serious personal injury or death caused by the work equipment or by the machine tipping over due to overloading, do not use the machine beyond the permitted performance of the machine such as the maximum permitted load for the structure of the machine.
- When passing over bridges or structures, check first that the structure is strong enough to support the weight of the machine. When passing on a public road, check with authorities concerned and observe their instruction.
- When operating in tunnels, under bridges, under electric wires, or other places where the height is limited, operate slowly and be extremely careful not to let the machine body or work equipment hit anything.
- For machines with canopy, spilled soil from the bucket may fall onto the floor when swinging leftward maximum by small radius. Be careful when operating this work.

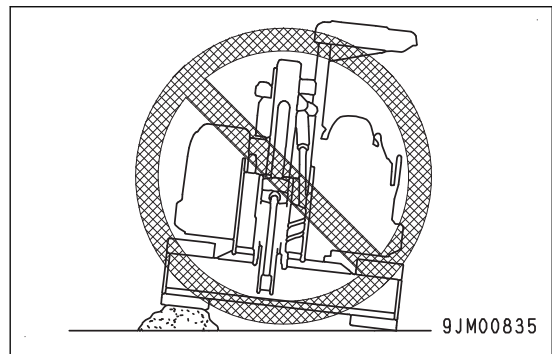

PRECAUTIONS WHEN TRAVELING ON SLOPES

To prevent the machine from tipping over or slipping to the side, always observe the following.

- Keep the work equipment at height (a) 20 to 30 cm {7.9 to 11.8 in} above the ground. In case of emergency, lower the work equipment to the ground immediately to help stopping the machine.
- When driving the machine up slopes, set the operator's cab facing uphill, when driving downhill, set the operator's cab facing downhill. Always be sure of the safety of the ground under the front of the machine when driving.

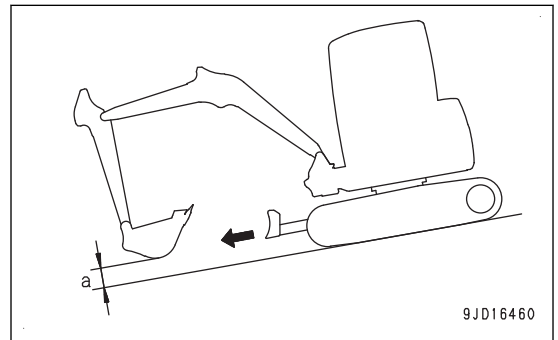
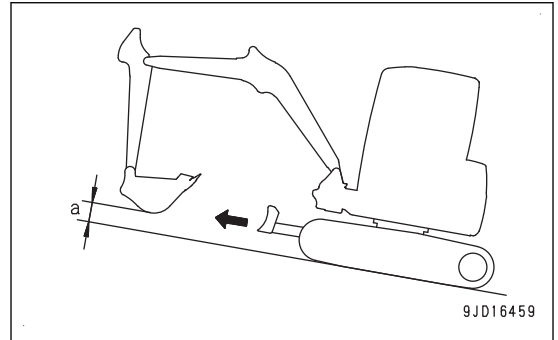

- When driving the machine up a steep slope, extend the work equipment to the front to improve the balance, keep the work equipment at height (a) of 20 to 30 cm {7.9 to 11.8 in} above the ground, and drive it at low speed.

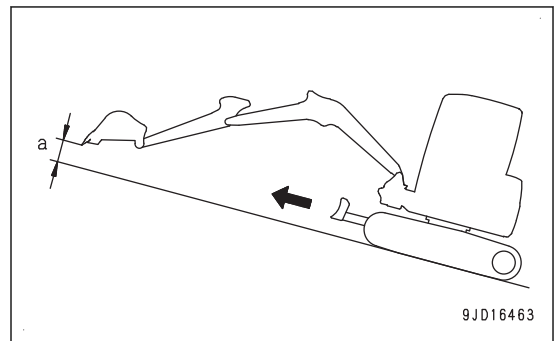

- When driving the machine downhill, lower the engine speed, keep the travel lever close to NEUTRAL position, and drive it at low speed.

When driving the machine down the steep hills of 15° or more, set the sprocket side downward, and drive with lower engine speed in the posture shown in the figure.

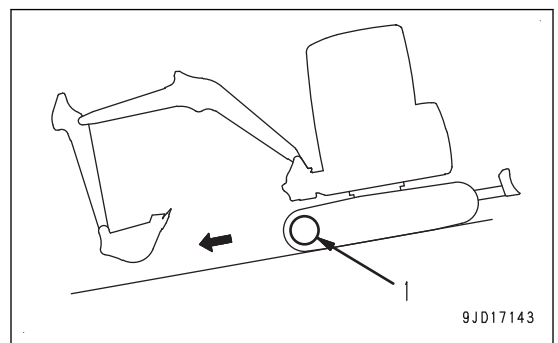

- Always drive the machine straight up or down a slope. Driving the machine at an angle or across the slope is extremely dangerous.
- Do not turn on slopes or drive across slopes. Always go down to a flat place to change the position of the machine, then drive it on to the slope again.

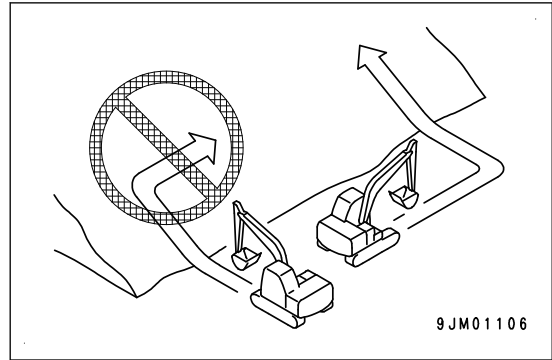

- Do not drive the machine on a slope covered with the steel plates. Even with slight slopes there is a hazard that the machine may slip.
- Drive the machine at low speed on the grass or fallen leaves. Even with slight slopes, there is a hazard that the machine may slip.
- If the engine stops, move the control levers immediately to NEUTRAL position, set the lock lever to LOCK position, and then start the engine.

PRECAUTIONS WHEN OPERATING ON SLOPES

- When working on slopes, there is a hazard that the machine may lose its balance and turn over when performing swing or work equipment operations. This may lead to serious personal injury or death. Always provide a stable place when performing these operations, and operate carefully.
- Do not swing the work equipment from the uphill side to the downhill side when the bucket is loaded. This operation is dangerous, and may cause the machine to turn over.
- If the machine has to be used on a slope, pile the soil to make a platform (A) that will keep the machine as horizontal as possible.
- Do not work on a slope covered with the steel plates. Even with slight slopes there is a hazard that the machine may slip.

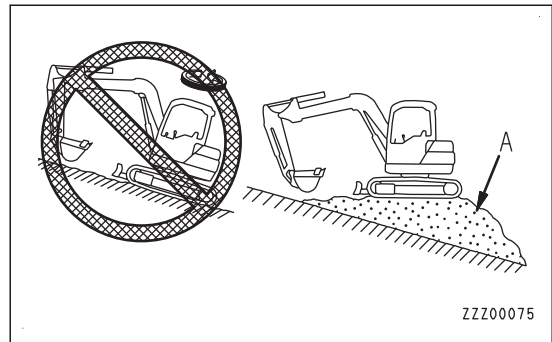

PROHIBITED OPERATIONS

If the machine turns over or falls, or the ground at the working point collapses, or a structure being demolished collapses, it may lead to serious personal injury or death. Always observe the following.

- It is dangerous to work under an overhang. Mudslide or rockfall may occur, or the overhang may collapse. Never perform digging under an overhang.

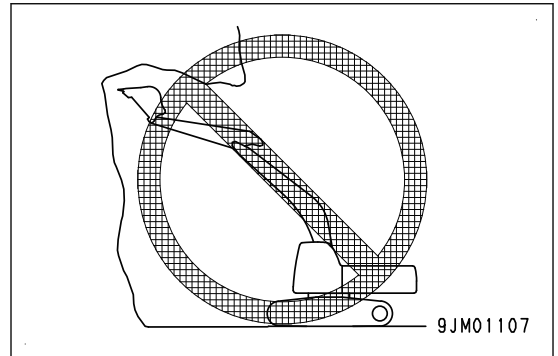

- Do not excavate too deeply under the front of the machine. The ground under the machine may collapse and cause the machine to fall.

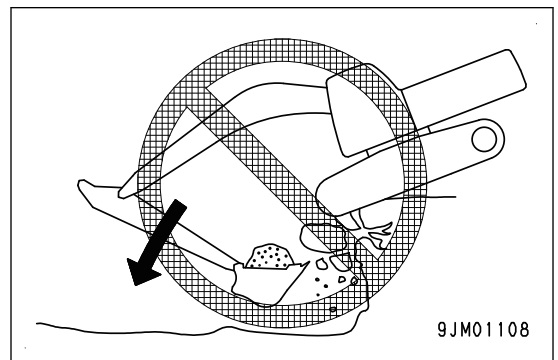

- For a quick escape in an emergency, set the tracks at right angles to the road shoulder or cliff with the sprocket at the rear when performing operations.

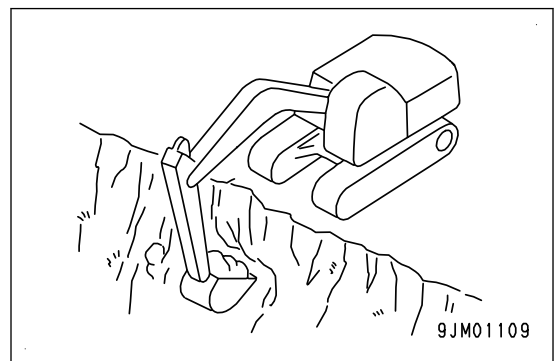

- Do not demolish the structure where the machine is placed on. It is dangerous that the structure may collapse and the machine may fall.

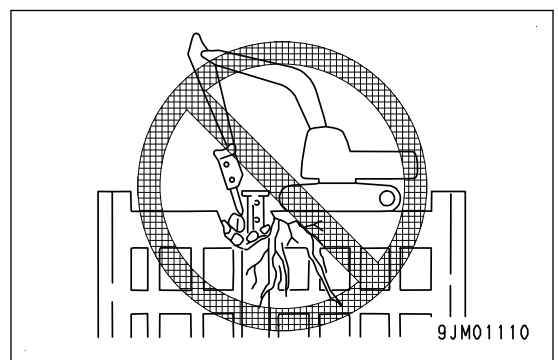

- Do not demolish the structure above the machine. It is dangerous that broken parts may fall or the structure may collapse, and it may cause serious injury or death.

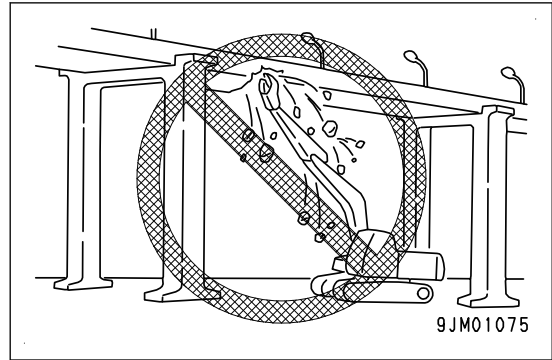

- Do not perform demolition work by using the impact force of the work equipment. Scattered pieces of broken materials, or damage of the work equipment, or the machine tipping over due to reaction from the impact may cause serious personal injury or death.

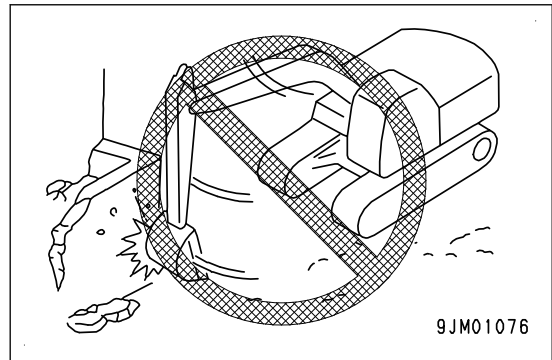

- Do not pass the bucket over the heads of other workers or over the operator's seat of dump trucks or other hauling equipment. There is a danger that the load may spill or the bucket may hit the dump truck and cause serious personal injury or death.
- When working on or from the top of buildings or other structures, check the strength and the structure before starting operations. There is a hazard of the building collapsing and causing serious injury or death.
- Generally speaking, the machine is more liable to tip over when the work equipment is at the side than when it is at the front or rear of the machine.
Be extremely careful when swinging the work equipment from the front or rear to the side of machine while it is applied a load. It is dangerous that the machine may tip over.
- When using a breaker or other heavy work equipment, it is dangerous that the machine may lose its balance and tip over. When operating the machine on the flat ground as well as on slopes, observe the following.
 - Do not suddenly lower, swing, or stop the work equipment.
 - Do not suddenly extend or retract the boom cylinder. It is dangerous that the machine may tip over by the impact.

PRECAUTIONS WHEN OPERATING ON SNOW OR FROZEN SURFACES

- Snow-covered or frozen surfaces are slippery, so be extremely careful when traveling or operating the machine, and do not perform abrupt lever operation. Machine may slip even on a slight slope. Be particularly careful when working on slopes.
- Frozen road becomes soft when the temperature rises, and the machine may tip over or be not able to escape. Be particularly careful when working on frozen road.
- It is dangerous that the machine enters deep snow. The machine may tip over or become buried in the snow. Be careful not to go off the road or to get trapped in a drift of snow.
- When performing snow removal, the road and objects placed beside the road are buried in the snow and cannot be seen. Be careful.

PRECAUTIONS WHEN PARKING MACHINE

Unexpected move of the parked machine can cause serious personal injury or death. Observe the following.

- Park the machine on a firm, level ground.
- Select a place where there is no hazard of landslides, falling rocks, or flooding.
- Lower the work equipment to the ground.

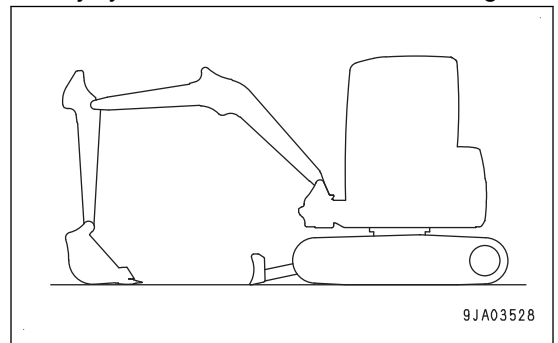

- When leaving the machine, be sure to make the undercarriage and upper structure point to the same direction, lower the work equipment and blade to the ground, grip the operating portion on top of the lock lever (1) to set the lock lever (1) to LOCK position (L), and stop the engine.
- If the seat is positioned forward, your body or clothes will easily touch the levers. Shift the seat backward to keep enough space, and then get off the machine.
- Close the operator's cab door, and lock all the places. Remove the key so that any unauthorized person cannot operate the machine, and keep it in the specified place.
- If it is necessary to park the machine on a slope, always observe the following.
 - Set the work equipment to face the downhill side and thrust it in the ground.
 - In addition, block the tracks from movement.

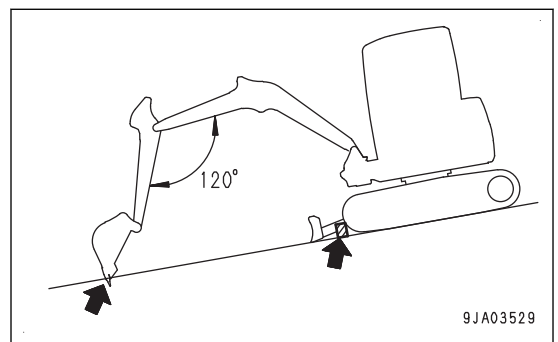
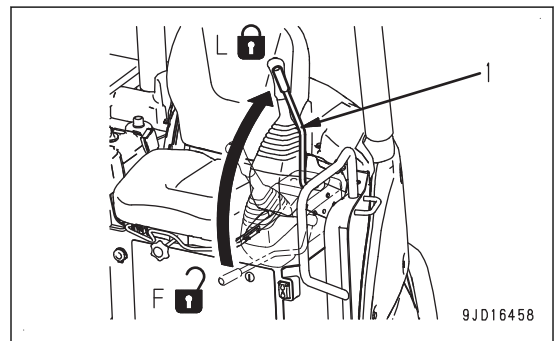

PRECAUTIONS FOR TRANSPORTATION

When the machine is transported on a trailer, serious personal injury or death may result because of the accident during transportation. Always observe the following.

- Always check the machine dimensions carefully. Depending on the work equipment and optional devices installed, the machine weight, transportation height, and overall length differ.
- Check beforehand that all bridges and other structures on the transportation route are strong enough to withstand the combined weight of the transporter and the machine being transported.
- This machine may need to be divided into components for transportation depending on the regulation. When transporting the machine, consult your Komatsu distributor.

PRECAUTIONS WHEN LOADING AND UNLOADING

If handling is improper when loading or unloading the machine, it is dangerous that the machine may tip over or fall. It requires particular attention. Always observe the following.

- Perform loading and unloading on a firm, level ground only. Avoid road edge or place near the cliff.
- Never use the work equipment to load or unload the machine. There is danger that the machine may fall or tip over.
- Always use ramps of adequate strength. Be sure that the ramps are wide, long, and thick enough to provide a safe loading slope. Take suitable steps to prevent the ramps from moving out of position or coming off.

(1) Chocks

(2) Ramp

(3) Ramp width

(4) Angle of ramp: Max. 15°

(5) Block

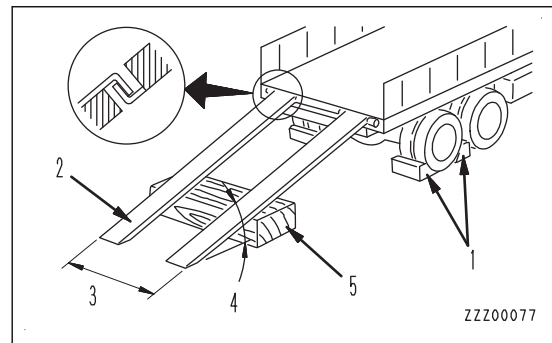

- Be sure the ramp surface and the platform of trailer are clean and free of grease, oil, ice, water and other loose materials. If any, remove them. Remove dirt around the undercarriage of the machine. On a rainy day, in particular, be extremely careful since the ramp surface is slippery.
- Run the engine at low idle and drive the machine slowly at low speed.
- When on the ramps, do not operate any lever except for the travel lever (travel forward and reverse).
- Never correct your steering on the ramps. If necessary, drive off the ramps onto the ground, correct the direction, then enter the ramps again.
- The center of gravity of the machine will change suddenly at the joint between the ramps and the loading platform, and there is danger of the machine losing its balance. Drive slowly over this point.
- When loading or unloading to an embankment or platform, make sure that it has suitable width, strength, and grade.
- When swinging the upper structure on the loading platform, lower the work equipment, retract it, and perform the operation slowly.
- For machines equipped with a cab, always lock the door after loading the machine. To prevent the door from opening during transportation.
- When the handrail is required to be removed, be careful not to lose it. When reinstalling the handrail, be sure to install it securely.

TOWING AND BEING TOWED

PRECAUTIONS FOR TOWING AND BEING TOWED

Always use the correct towing equipment and towing method. Any mistake in the selection of the wire rope or drawbar or the method of towing a failed machine and being towed may lead to serious personal injury or death.

- Always confirm that the wire rope or drawbar used for towing has ample strength for the weight of the machine being towed.
- Never use the wire rope which has breaks in strands (A), reduced diameter (B), or kinks (C). There is a danger that the rope may break during the towing operation.
- Always wear leather gloves when handling the wire rope.
- Never tow a machine on a slope.
- During the towing operation, never stand between the towing machine and the machine being towed.

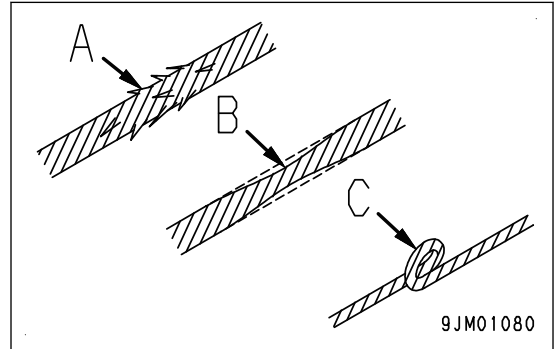

LIFTING OPERATION BY USING BUCKET WITH HOOK

PRECAUTIONS FOR LIFTING OPERATIONS

Falling of a lifted load or tipping over of the machine can cause serious personal injury or death. Always observe the following.

- Do not perform lifting work on slopes, soft ground, or other places where the machine is not stable.
- Use wire rope that conforms to the specified standard.
- Do not perform any lifting operation with a load heavier than the specified lifting load. It may cause a serious accident such as tipping over of the machine.
- Determine the signals to be used and place a signaller in position.
- Prohibit anyone to enter the place where there is danger of contact with a lifted load or the danger from a falling load.
- It is dangerous if a lifted load hits any person or structure. When operating the swing or work equipment, always check carefully that the surrounding area is safe.
- Do not start, swing, or stop the machine suddenly. It is dangerous that the lifted load may swing.
- Do not use the work equipment or swing to pull the load in any direction. There is danger that the hook may break and the load come off, causing the work equipment to move suddenly and cause personal injury.
- Do not leave the operator's seat while the load is being lifted.

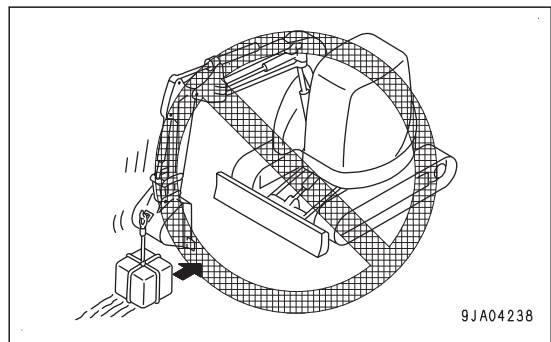
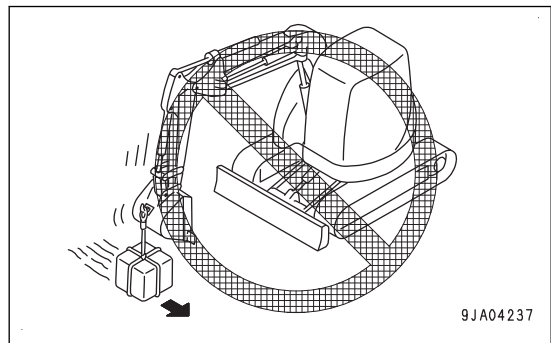

PRECAUTIONS FOR MAINTENANCE

PRECAUTIONS BEFORE STARTING INSPECTION AND MAINTENANCE

DISPLAY WARNING TAG DURING INSPECTION AND MAINTENANCE

During inspection and maintenance, always display the "DANGER! Do NOT operate!" warning tag.

If there is a "DANGER! Do NOT operate!" warning tag displayed, it means that someone is performing inspection and maintenance of the machine. If the warning tag is ignored and the machine is operated, the person performing inspection or maintenance may be caught in the rotating parts or moving parts. It is dangerous and may cause serious personal injury or death. Do not start the engine or touch the levers.

If necessary, put up signs around the machine as well.

Warning tag part No. 09963-03001

When not using this warning tag, keep it in the toolbox. If there is no toolbox, keep it in the pocket for Operation and Maintenance Manual

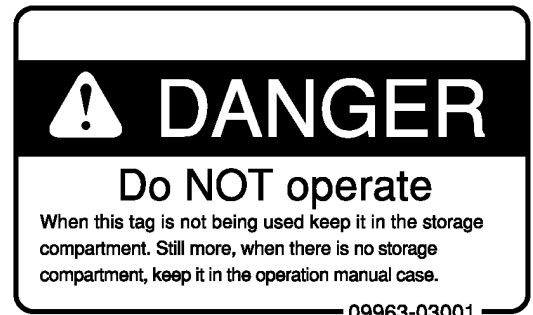
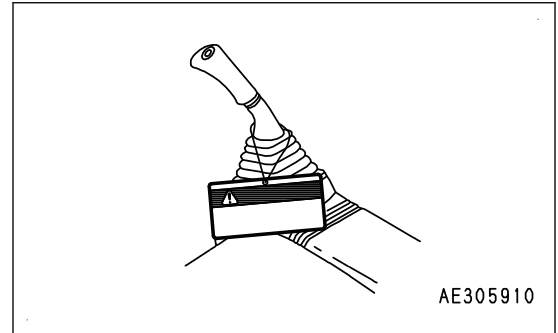

KEEP WORK PLACE CLEAN AND TIDY

Do not leave hammers or other tools lying around in the work place. Wipe up all grease, oil, or other substances that will cause you to slip. Always keep the work place clean and tidy to enable you to perform operations safely.

If the work place is not kept clean and tidy, there is the danger that you will trip, slip, or fall over and injure yourself.

SELECT SUITABLE PLACE FOR INSPECTION AND MAINTENANCE

- Stop the machine on a firm, level ground.
- Select a place where there is no hazard of landslides, falling rocks, or flooding.

ONLY AUTHORIZED PERSONNEL

As long as maintenance of the machine is continued, do not allow unauthorized person to come near the work-place. They might get unexpected personal injury from, for instance, touching machine. Do not allow anyone except the workers concerned to enter the workplace. If necessary, employ a guard.

APPOINT LEADER WHEN WORKING WITH OTHERS

When repairing the machine or when removing and installing the work equipment, appoint a leader and follow his/hers instructions during the operation in order to prevent personal injuries caused by being caught or pinched.

STOP ENGINE BEFORE CARRYING OUT INSPECTION AND MAINTENANCE

If you are caught or pinched between the work equipment during operation, or exposed to high-temperature or high-pressure liquids, it is dangerous and may cause serious personal injury or death. Always observe the following.

- Lower the work equipment to the ground and stop the engine before performing any inspection and maintenance.
- Turn the starting switch to ON position. Operate the work equipment control lever back and forth, right and left a few times fully to release the remaining internal pressure in the hydraulic circuit. Then move lock lever (1) to LOCK position (L) and turn the starting switch to OFF position.
- Check that the battery relay is off and main power is not conducted. (After turning the starting switch to OFF position, wait for approximately 1 minute and press the horn switch. If the horn does not sound, power is not conducted.)
- Block the tracks from movement.

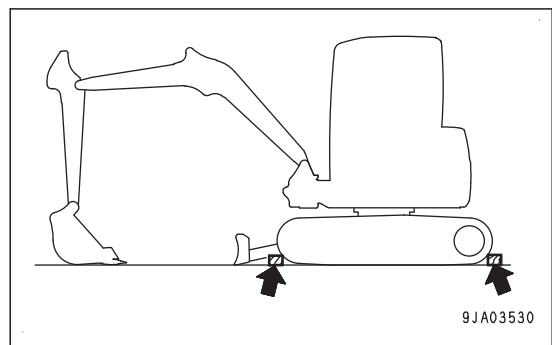
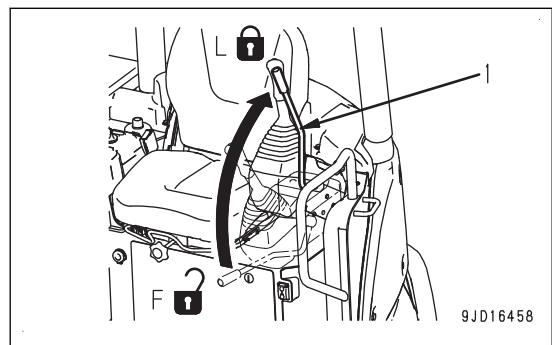
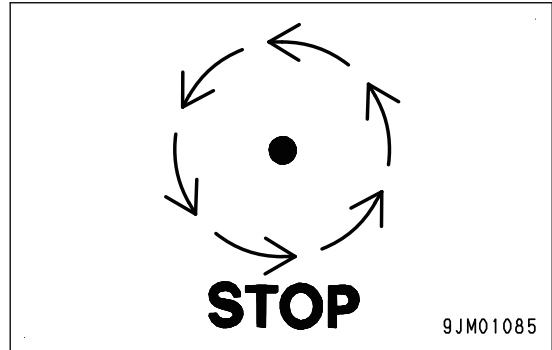

PRECAUTIONS FOR OPENING AND CLOSING FLOOR

- Do not open the floor on the slope ground or in windy weather, otherwise it may lead to serious personal injury or death.
- Do not open the floor when the engine is running, the door (if the machine is equipped with the cab) is open, or the lock lever is in Free position, otherwise it may lead to serious personal injury or death.
- Immediately after the engine is stopped, its parts and oil are still very hot and may cause burn injury. Check that the temperature inside of engine compartment has been dropped before performing the opening or closing of floor.
- Do not get on the operator's seat when floor is opened, otherwise it may lead to serious personal injury or death by fall.

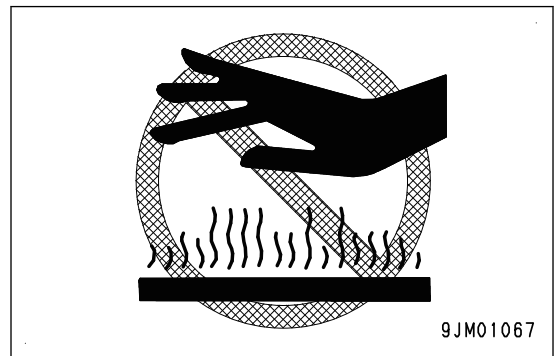
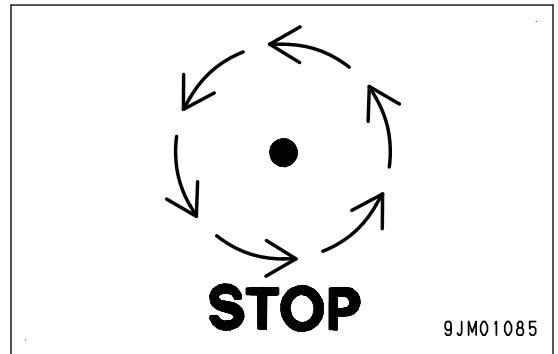

TWO WORKERS FOR MAINTENANCE WHEN ENGINE IS RUNNING

To prevent an accident, do not perform the maintenance with the engine running. When it is necessary to perform the maintenance with the engine running, always observe the following.

- One worker must always sit on the operator's seat and be ready to stop the engine at any time. All workers must maintain contact with the other workers.
- Rotating parts such as the fan, fan belt are dangerous that they may easily catch a body part or an object someone wears. Be careful not to come close to the rotating part.
- Never drop or insert tools or other objects into the fan, fan belt, or other rotating parts. They may contact the rotating parts and break, and be scattered. It is dangerous.
- If the automatic active regeneration of KDPF starts during the maintenance work, the temperature around KDPF becomes high.
- Release the remaining pressure in the hydraulic system, and place the lock lever (1) to LOCK position (L).
- Do not touch the control levers or pedals. When it is necessary to operate the control levers or pedals, always give a signal to your fellow workers to evacuate them to a safe place.

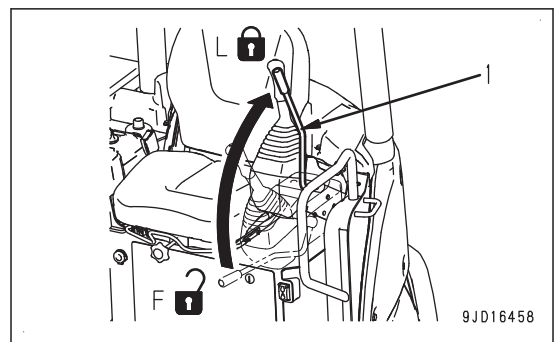
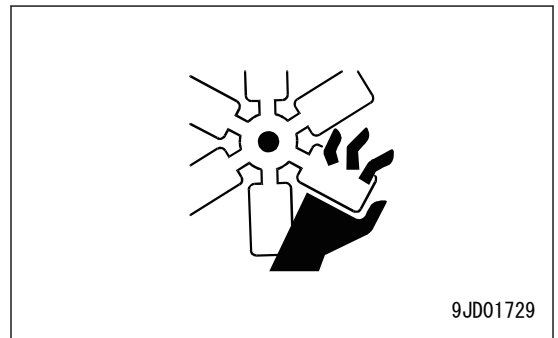

PRECAUTIONS WHEN INSTALLING, REMOVING, OR STORING ATTACHMENTS

- Appoint a leader before starting removal or installation operations for attachments.
- Place attachments that have been removed from the machine in a stable condition so that they do not fall. And take steps to prevent unauthorized persons from entering the storage area.

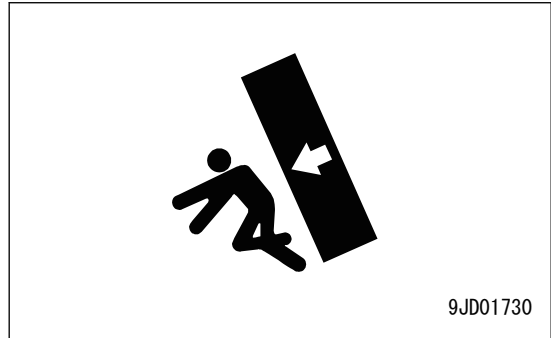

PRECAUTIONS WHEN WORKING UNDER MACHINE OR WORK EQUIPMENT

Machine or work equipment may fall, and it is dangerous that serious personal injury or death may occur. Always observe the following.

- Make sure the hoists or hydraulic jacks you use are in good condition and strong enough to handle the weight of the component. Never use hydraulic jacks at places where the machine is damaged, bent, or twisted. Never use if the element wire of wire rope is frayed, twisted or pinched. Never use bent or distorted hooks.
- It is extremely dangerous to work under the machine if the track shoes are lifted off the ground and the machine is supported only with the work equipment. If any of the control levers is touched by accident, or there is damage occurring to the hydraulic piping, the work equipment or the machine will suddenly fall. Never work under the work equipment or the machine.
- If it is necessary to raise the work equipment or the machine and then go under it to perform inspection or maintenance, support the work equipment and machine securely with blocks and stands strong enough to support the weight of the work equipment and machine.
If the work equipment and machine are not supported, they may come down and it may cause serious personal injury or death.
- Never use concrete blocks for supports. Concrete blocks may break under even light loads.



USE PROPER TOOLS

Use the tools suited to the task and use them correctly. Using damaged, deformed, or low quality tools, or making improper use of the tools may cause serious personal injury or death.

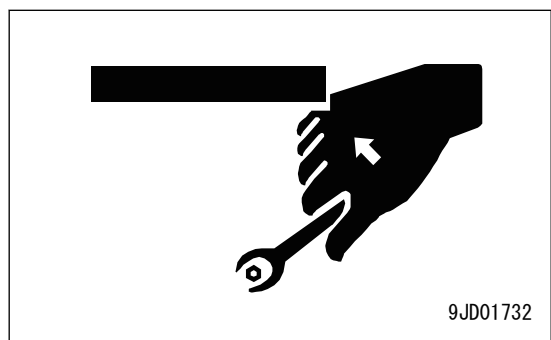

PRECAUTIONS FOR CHECK AND MAINTENANCE

PRECAUTIONS FOR WELDING

Welding operations must always be performed by a qualified welder and in a place equipped with proper equipment. There is a hazard of gas, fire, or electric shock when performing welding, so never allow any unqualified person to perform welding.

HANDLE BATTERY

Starting switch should be always in OFF position when testing the battery or handling it.

When the machine is equipped with the battery disconnect switch, turn the starting switch to OFF position and, after checking that the system operating lamp is not lit, set the battery disconnect switch key to OFF position, and pull it out.

Danger of battery exploding

When the battery is being charged, flammable hydrogen gas is generated and may explode. In addition, the battery electrolyte includes dilute sulphuric acid. Any mistake in handling may cause serious personal injury, explosion, or fire, so always observe the following.

- Do not use or charge the battery if the battery electrolyte is below LOWER LEVEL mark. This may cause an explosion. Always perform periodic inspection of the battery electrolyte level, and add purified water (such as a commercial battery fluid) to UPPER LEVEL mark.
- Do not use a dry wipe to clean the battery. A wet wipe will prevent fire or explosion from static electricity.
- Do not smoke or bring any open flame close to the battery.
- Hydrogen gas is generated when the battery is being charged, so remove the battery from the machine, take it to a well-ventilated place, remove the battery caps, then perform the charging.
- After charging, tighten the battery caps securely.

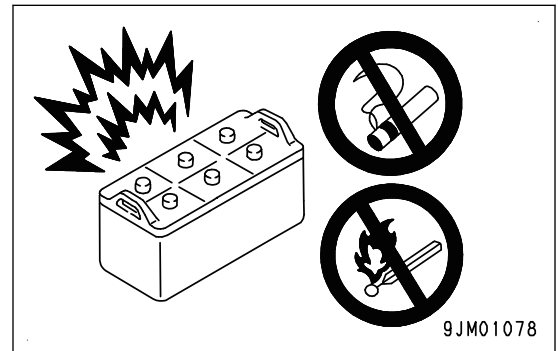

Danger from dilute sulphuric acid

When the battery is being charged, flammable hydrogen gas is generated and may explode. In addition, the battery electrolyte includes dilute sulphuric acid. Any mistake in handling may cause serious personal injury, explosion, or fire. Always observe the following.

- When handling the battery, always wear protective eye-glasses and rubber gloves.
- If battery electrolyte gets into your eyes, immediately wash your eyes with large amounts of fresh water. After that, get medical attention immediately.
- If battery electrolyte gets on your clothes or skin, wash it off immediately with large amounts of water.

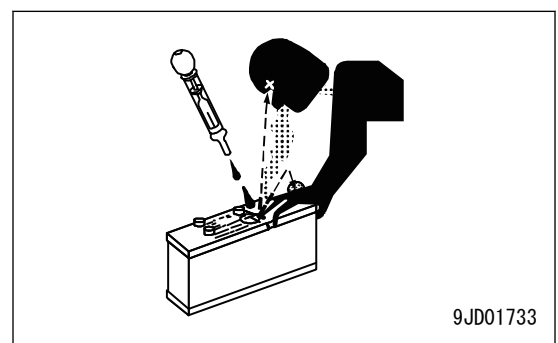

Danger of sparks

Sparks may be generated and they can cause a fire. Always observe the following.

- Do not let tools or other metal objects make any contact between the battery cables. Do not leave tools lying around near the battery.
- Turn the starting switch to OFF position, wait for approximately 2 minutes, remove the earth side terminal ((-) terminal side) first, and remove the battery terminal.

When the machine is equipped with the battery disconnect switch, turn the starting switch to OFF position and, after checking that the system operating lamp is not lit, set the battery disconnect switch key to OFF position, and pull it out.

- Tighten the battery cable terminals securely.
- Secure the battery firmly in the specified position. Be careful that the fittings should not come to contact with the terminal at this time.
- Install the cover above the battery so that it envelops the battery and it is not flipped. If the cover is damaged, replace it immediately.
- If chloride is accumulated on the top surface of battery and around terminals, clean them with warm water of approximately 40 °C {104 °F} , dry them thoroughly, and connect the battery cable to them.

PRECAUTIONS WHEN USING HAMMER

When using a hammer, pins may come out or metal particles may be scattered. It is dangerous and may cause serious personal injury or death. Always observe the following.

- When hitting pins or bucket teeth, broken pieces may be scattered, and it may cause personal injury to the people in the surrounding area. Always check that there is no one in the surrounding area.
- If hard metal parts such as pins, bucket teeth, cutting edges, or bearings are hit with a hammer, pieces might be scattered, and it may cause serious personal injury or death. Always wear protective eyeglasses and gloves.
- If the pin is hit with strong force, it may come out, and injure people in the surrounding area. Do not allow anyone to enter the surrounding area.

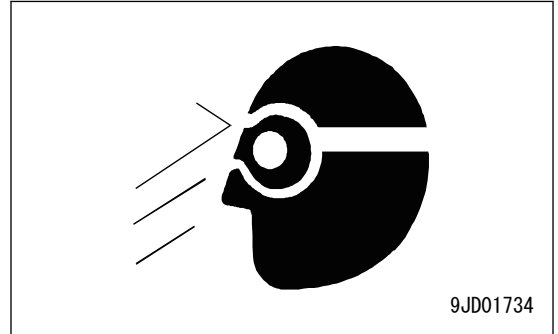

PRECAUTIONS FOR HIGH-TEMPERATURE COOLANT

To prevent burns from boiling water or steam spurting out when checking or draining the coolant, wait for the coolant to cool down to a temperature where the radiator cap can be touched by hand. Then loosen the cap slowly to release the pressure inside the radiator, and remove the cap.

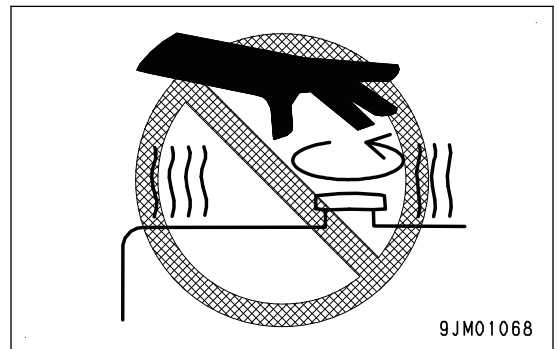

PRECAUTIONS FOR HIGH-TEMPERATURE OIL

To prevent burns from hot oil spurting out or from touching high-temperature parts when checking or draining the oil, wait for the oil to cool down to a temperature where the cap or plug can be touched by hand. Then, loosen the cap or plug slowly to release the internal pressure and remove the cap or plug.

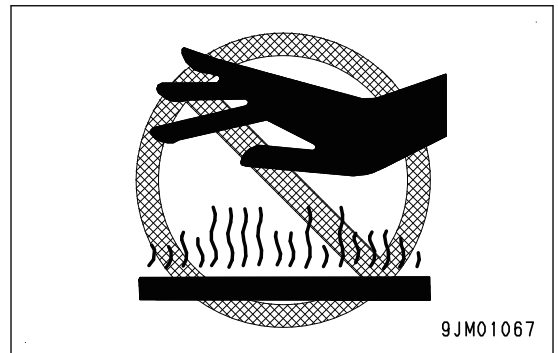

PRECAUTIONS FOR HIGH-TEMPERATURE PARTS

To prevent burns from touching high-temperature parts, when checking or performing maintenance after stopping engine, check the parts have been cooled down to touch with bare hand before checking or maintenance.

PRECAUTIONS FOR HIGH-PRESSURE OIL

The hydraulic system is always under internal pressure. In addition, the fuel piping is also under internal pressure when the engine is running and immediately after the engine is stopped. When performing inspection or replacement of the piping or hoses, check that the internal pressure in the circuit has been released. If this is not done, serious personal injury or death may result. Always observe the following.

- Do not perform inspection or replacement work with the circuit under pressure.
- If there is any leakage from the piping or hoses, the surrounding area may be wet, so check for cracks in the piping and hoses and for swelling in the hoses.
When performing inspection, wear protective equipment such as protective eyeglasses and leather gloves.

- High-pressure oil leaking from small holes is dangerous that may penetrate your skin and cause loss of sight if it contacts your skin or eyes directly. If a jet of high-pressure oil hit your skin or eyes, and suffer injury, wash the place with clean water, and consult a doctor immediately for medical attention.

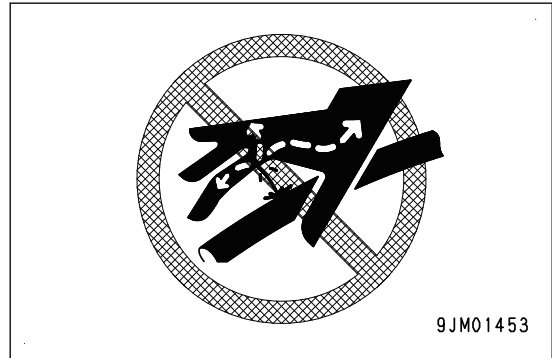

PRECAUTIONS FOR HIGH-PRESSURE FUEL

While the engine is running, high-pressure is generated in the engine fuel piping. If you try to disassemble the piping before the internal pressure is released, serious personal injury or death can result. When performing inspection or maintenance of the fuel piping system, stop the engine and wait for at least 30 seconds to allow the internal pressure to go down before starting the work.

HANDLE HIGH-PRESSURE HOSES AND PIPING

If oil or fuel leaks from high-pressure hoses or piping, it may cause fire or defective operation. It is dangerous and may cause serious personal injury or death. If the hose or piping mounts are loose or oil or fuel is found to be leaking from the mount, stop operations and tighten to the specified torque.

If any damaged or deformed hoses or piping are found, consult your Komatsu distributor.

Replace the hose if any of the following problems are found.

- Damaged hose or deformed hydraulic fitting.
- Frayed or cut covering or exposed reinforcement wire layer.
- Covering swollen in places.
- Twisted or crushed movable portion.
- Foreign material embedded in covering.

PRECAUTIONS FOR HIGH VOLTAGE

When the engine is running and immediately after it is stopped, high voltage is generated inside the engine controller and the engine injector, and there is danger of electric shock. Never touch the inside of the engine controller or the injector part of the engine. If it is necessary to touch the inside of the engine controller or the injector part of the engine, consult your Komatsu distributor.

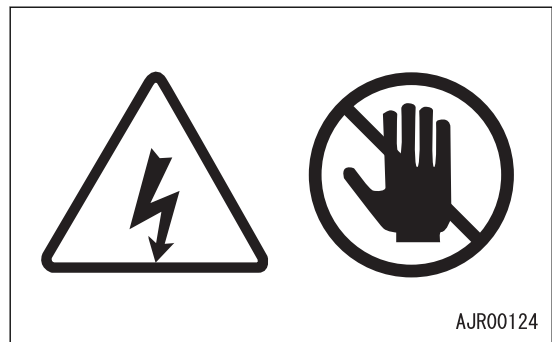

PRECAUTIONS FOR NOISE

When performing maintenance of the engine and you are exposed to noise for long periods of time, wear ear covers or ear plugs while working.

If the noise is too loud, it may cause temporary or permanent hearing problems.

PRECAUTIONS FOR HIGH-PRESSURE GREASE WHEN ADJUSTING TRACK TENSION

- Grease is pumped into the track tension adjustment system under high pressure. If the specified procedure for maintenance is not followed when making adjustment, grease drain plug (1) may fly out and cause serious injury or death or property damage.
- When loosening grease drain plug (1) to loosen the track tension, never loosen it more than 1 turn. Loosen the grease drain plug slowly.
- Never put your face, hands, feet, or any other part of your body close to grease drain plug (1).

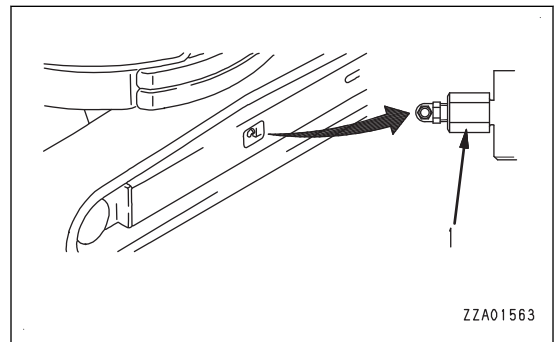

DO NOT DISASSEMBLE RECOIL SPRING

Never disassemble the recoil spring assembly.

The recoil spring assembly has a powerful spring that acts to reduce the impact on the idler. If it is disassembled by mistake, the spring may shoot out and cause serious personal injury or death. If it is necessary to disassemble it, ask your Komatsu distributor to perform the work.

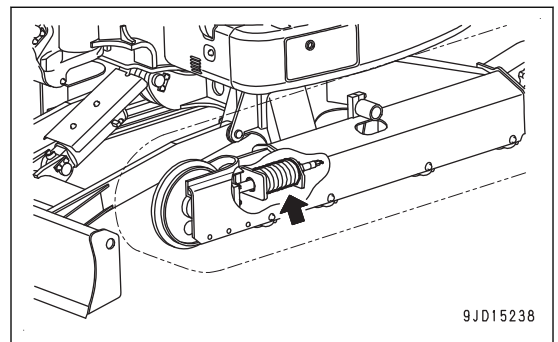

HANDLE ACCUMULATOR AND GAS SPRING

This machine is equipped with an accumulator. Even after the engine stops, if the work equipment control lever is operated after stop of the engine in the direction to lower the work equipment, the work equipment goes down with its own weight.

After stopping the engine, set the lock lever to LOCK position.

The accumulator and gas spring are charged with high-pressure nitrogen gas. If the accumulator is handled mistakenly, it may cause an explosion. It is dangerous and may cause serious personal injury or death. Always observe the following.

- Do not disassemble.
- Do not bring it near flame or dispose of it in fire.
- Do not make holes in it, weld it, nor use a cutting torch.
- Do not hit or roll the accumulator, or subject it to any impact.
- When disposing of the accumulator, the gas must be released. Ask your Komatsu distributor to perform this work.



PRECAUTIONS FOR COMPRESSED AIR

- When performing cleaning with compressed air, there is a hazard of serious personal injury or death caused by flying dust or particles.
- When using compressed air to clean the filter element or radiator, wear protective eyeglasses, anti-dust mask, gloves, and other protective equipment.

MAINTENANCE OF AIR CONDITIONER

If air conditioner refrigerant gets into your eyes, it may cause loss of sight; if it contacts your skin, it may cause frostbite. Never loosen any parts of the cooling circuit.

PRECAUTIONS FOR DISPOSING OF WASTE MATERIALS

To prevent pollution, pay full attention to the way to dispose of waste materials.

- Always drain the oil from your machine in containers. Never drain the oil and coolant directly onto the ground or dump into the sewage system, rivers, seas, or lakes.
- Obey appropriate laws and regulations when disposing of harmful objects such as oil, fuel, coolant, solvent, filters, and batteries.

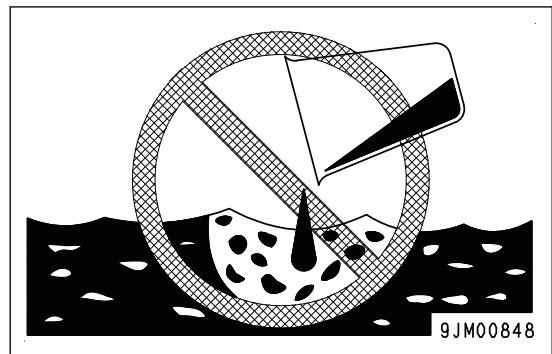

Avoid exposure to burning rubber or plastics which produce a toxic gas that is harmful to people.

- When disposing of parts made of rubber or plastics (hoses, cables, and harnesses), always comply with the local regulations for disposing industrial waste products.

METHOD FOR SELECTING WINDOW WASHER FLUID

Use an ethyl alcohol base washer liquid.

Methyl alcohol base washer liquid may irritate your eyes, so do not use it.

PERIODIC REPLACEMENT OF DEFINED LIFE PARTS

- For using the machine safely for a long period, always perform periodic replacement of the defined life parts that have a particularly close relation to safety, such as hoses and the seat belt.
Replacement of the defined life parts: See “PERIODIC REPLACEMENT OF DEFINED LIFE PARTS”.
- The material of these components naturally changes over time, and repeated use causes deterioration, wear, and fatigue. As a result, there is a hazard that these components may fail and cause serious personal injury or death. It is difficult to judge the remaining life of these components from external inspection or the feeling when operating, so always replace them at the specified interval.
- Replace or repair the defined life parts if any defect is found, even when they have not reached the specified replacement time.

OPERATION

WARNING

Please read and make sure that you understand the SAFETY section before reading this section.

GENERAL VIEW

MACHINE EQUIPMENT NAME

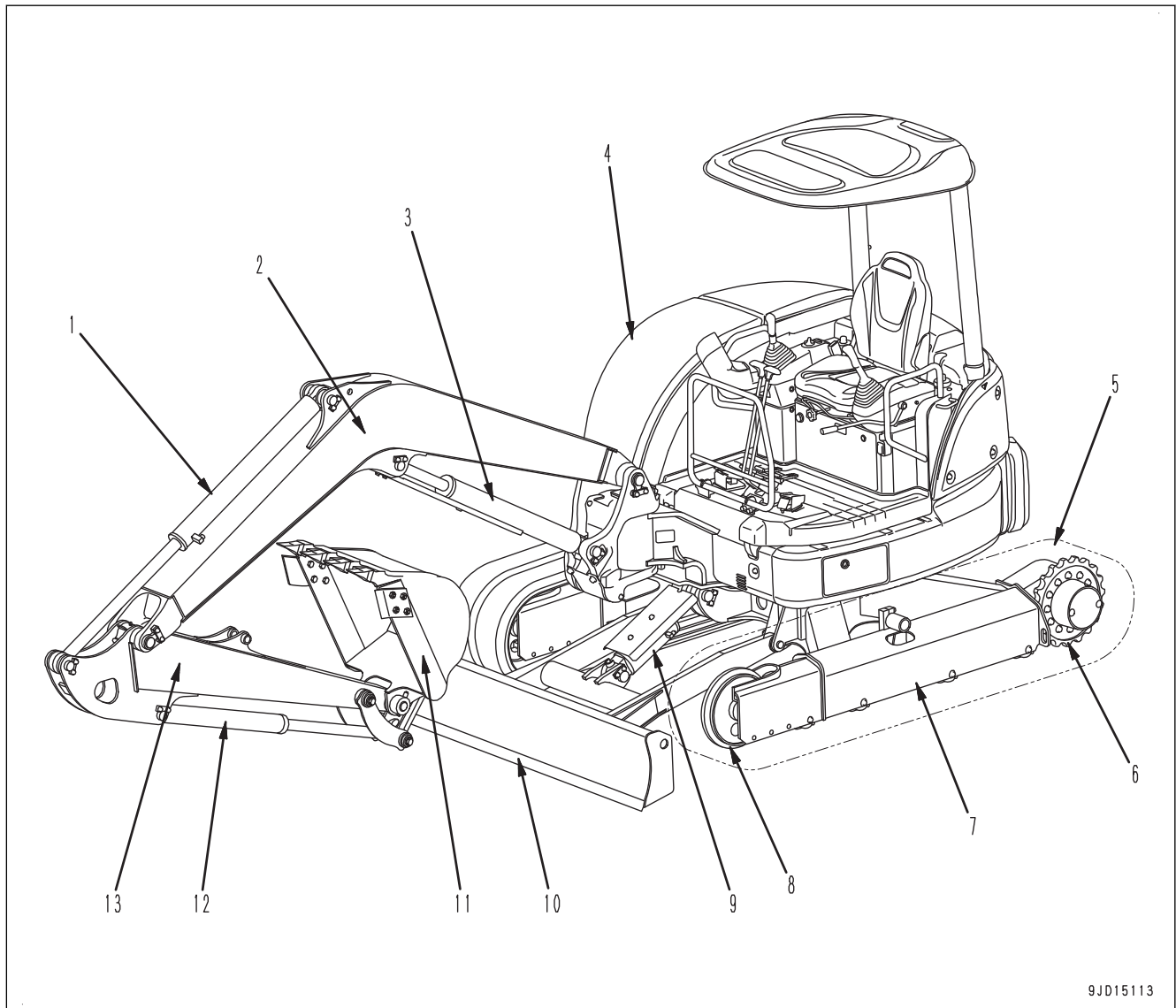

- (1) Arm cylinder
- (2) Boom
- (3) Boom cylinder
- (4) Dirt cover
- (5) Track
- (6) Sprocket
- (7) Track frame
- (8) Idler
- (9) Blade cylinder
- (10) Blade
- (11) Bucket
- (12) Bucket cylinder
- (13) Arm

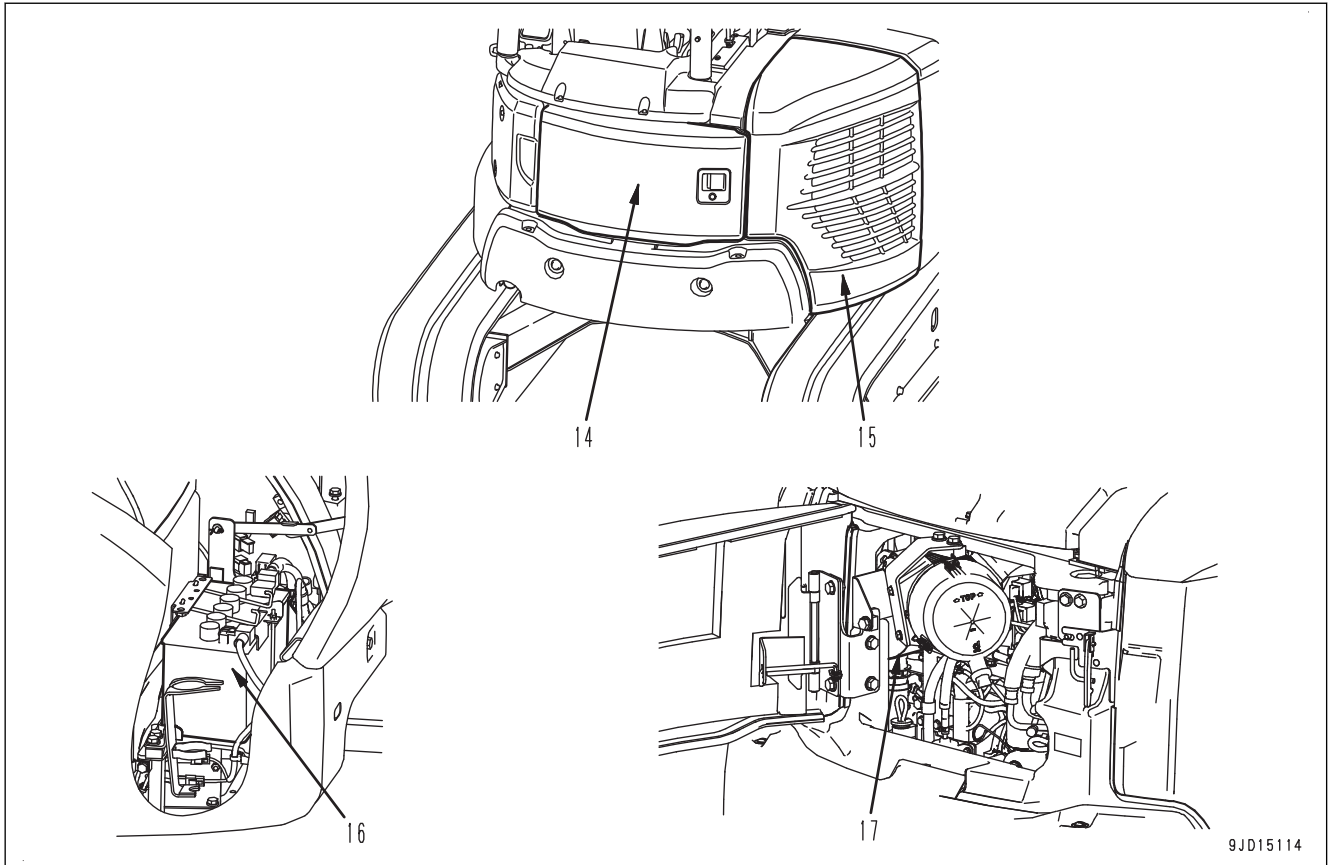

(14) Engine rear cover

(15) Cooling cover

(16) Battery

(17) KDPF

9JD15114

CONTROLS AND GAUGES NAMES

CONTROLS AND GAUGES NAMES: CANOPY SPEC

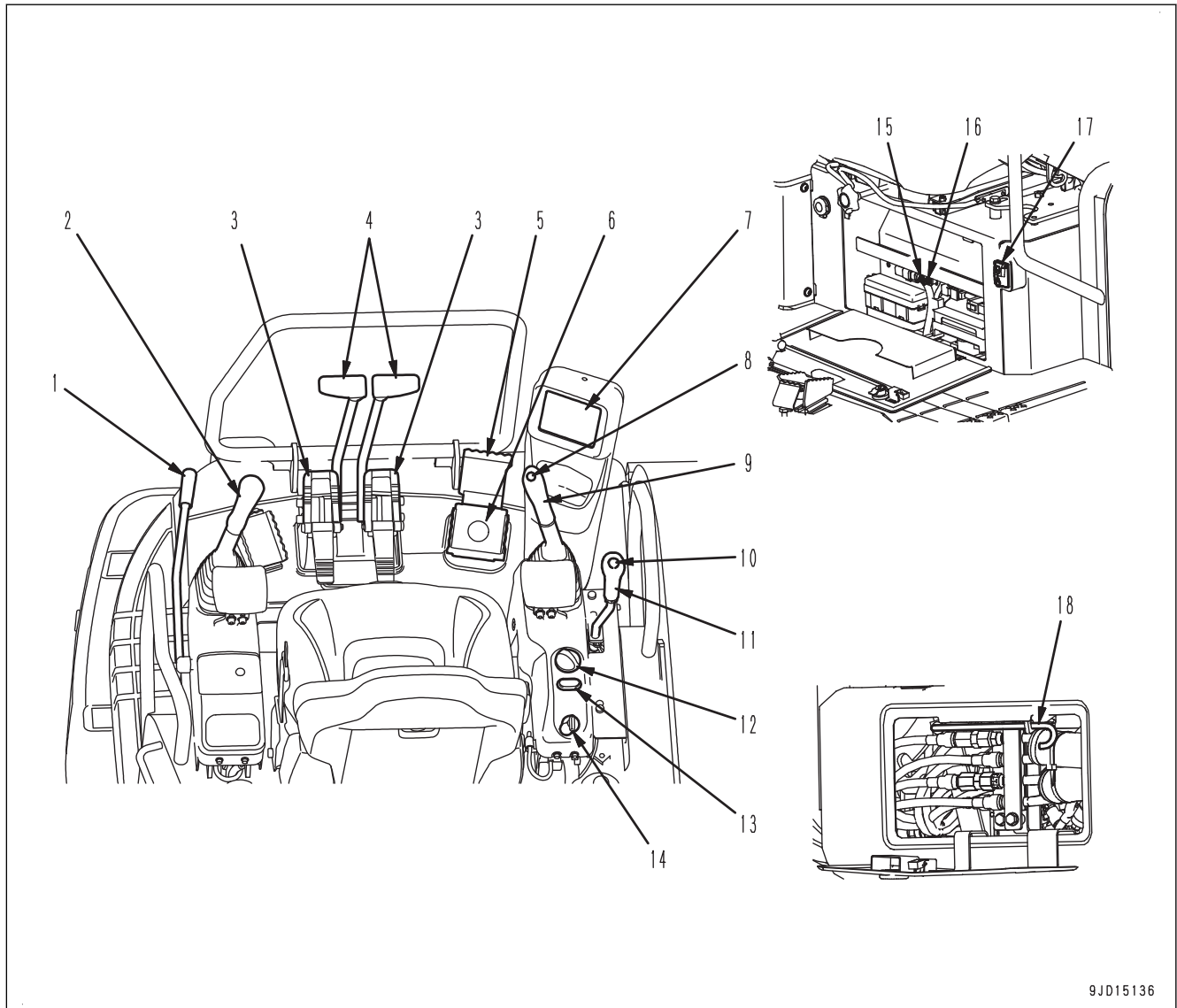

9JD15136

- | | |
|---------------------------------------|--|
| (1) Lock lever | (10) Travel speed selector switch |
| (2) L.H. work equipment control lever | (11) Blade control lever |
| (3) Travel pedal | (12) Fuel control dial |
| (4) Travel lever | (13) Lamp switch |
| (5) Swing lock cover | (14) Starting switch |
| (6) Boom swing control pedal | (15) Pump secondary drive switch |
| (7) Machine monitor | (16) Lock lever automatic lock cancel switch |
| (8) Horn switch | (17) Engine shutdown secondary switch |
| (9) R.H. work equipment control lever | (18) Floor lock release lever |

CONTROLS AND GAUGES NAMES: CAB SPEC

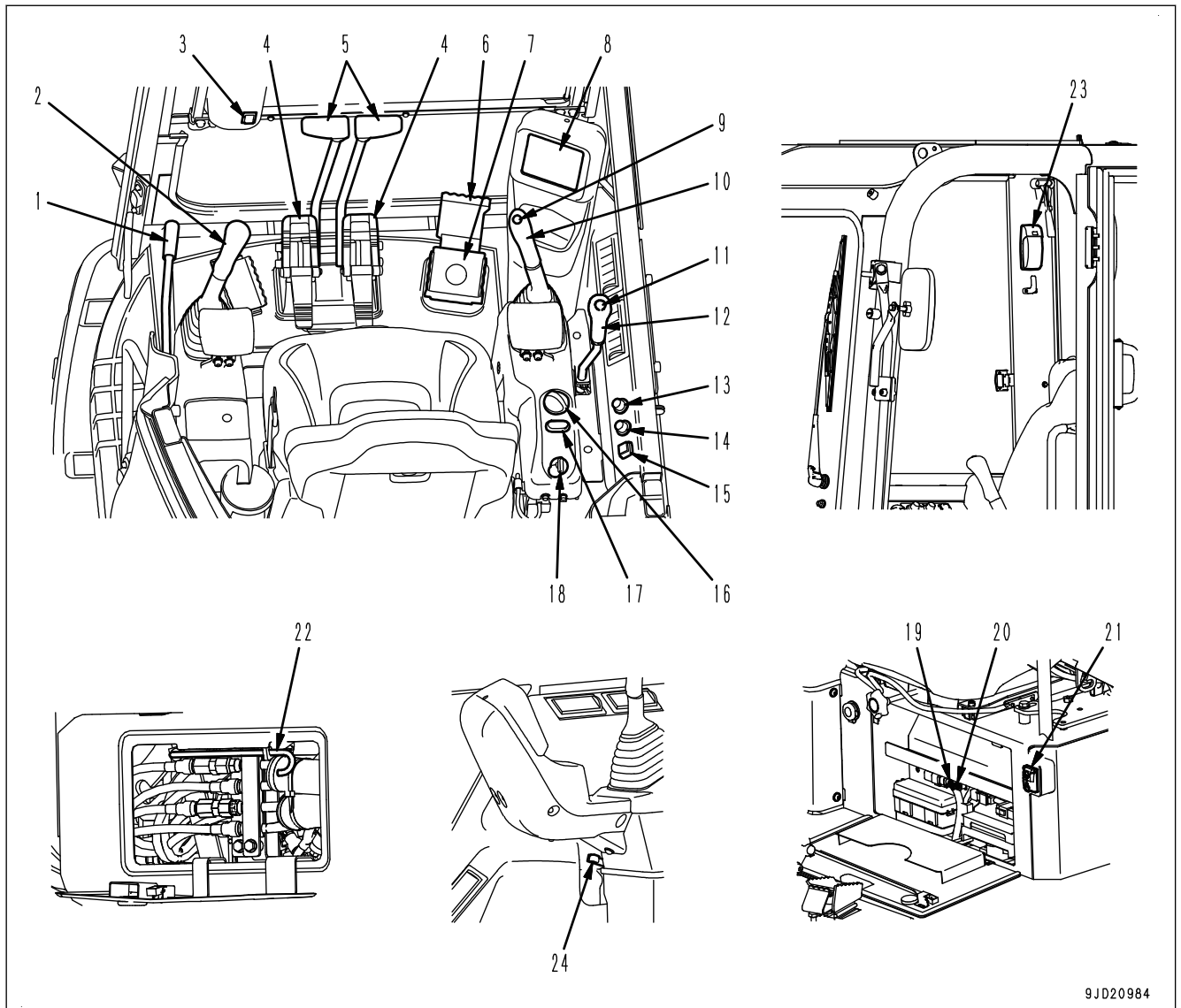

- | | |
|--|--|
| (1) Lock lever | (13) Temperature control switch |
| (2) L.H. work equipment control lever | (14) Air flow selector switch |
| (3) Wiper switch | (15) Air conditioner switch |
| (4) Travel pedal | (16) Fuel control dial |
| (5) Travel lever | (17) Lamp switch |
| (6) Swing lock cover | (18) Starting switch |
| (7) Boom swing control pedal | (19) Pump secondary drive switch |
| (8) Machine monitor | (20) Lock lever automatic lock cancel switch |
| (9) Horn switch | (21) Engine shutdown secondary switch |
| (10) R.H. work equipment control lever | (22) Floor lock release lever |
| (11) Travel speed selector switch | (23) Room lamp switch |
| (12) Blade control lever | (24) FRESH/RECIRC air selector lever |

9JD20984

MACHINE MONITOR EQUIPMENT NAME

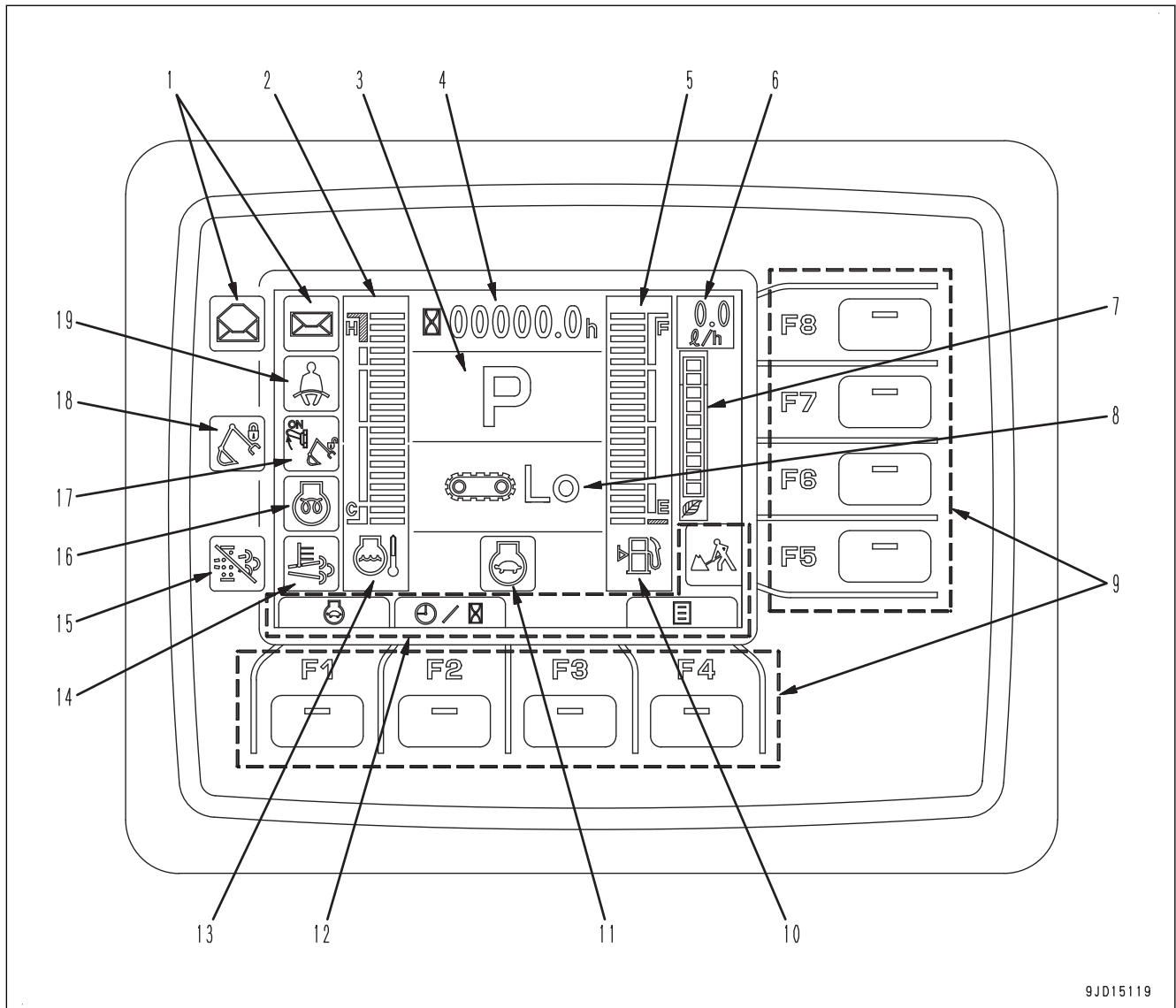

9JD15119

- | | |
|--------------------------------------|---|
| (1) Message display | (11) Auto-deceleration pilot lamp |
| (2) Engine coolant temperature gauge | (12) Guidance icon |
| (3) Working mode display | (13) Engine coolant temperature caution lamp |
| (4) Service meter/clock | (14) Aftertreatment devices regeneration pilot lamp |
| (5) Fuel gauge | (15) Aftertreatment devices regeneration disable pilot lamp |
| (6) Fuel consumption gauge | (16) Preheating pilot lamp |
| (7) ECO gauge | (17) Lock lever automatic lock cancel pilot lamp |
| (8) Travel speed display | (18) Lock lever pilot lamp |
| (9) Function switches "F1" to "F8" | (19) Seat belt caution lamp |
| (10) Fuel level caution lamp | |

REMARK

The above figure does not show all of the caution lamp symbols.

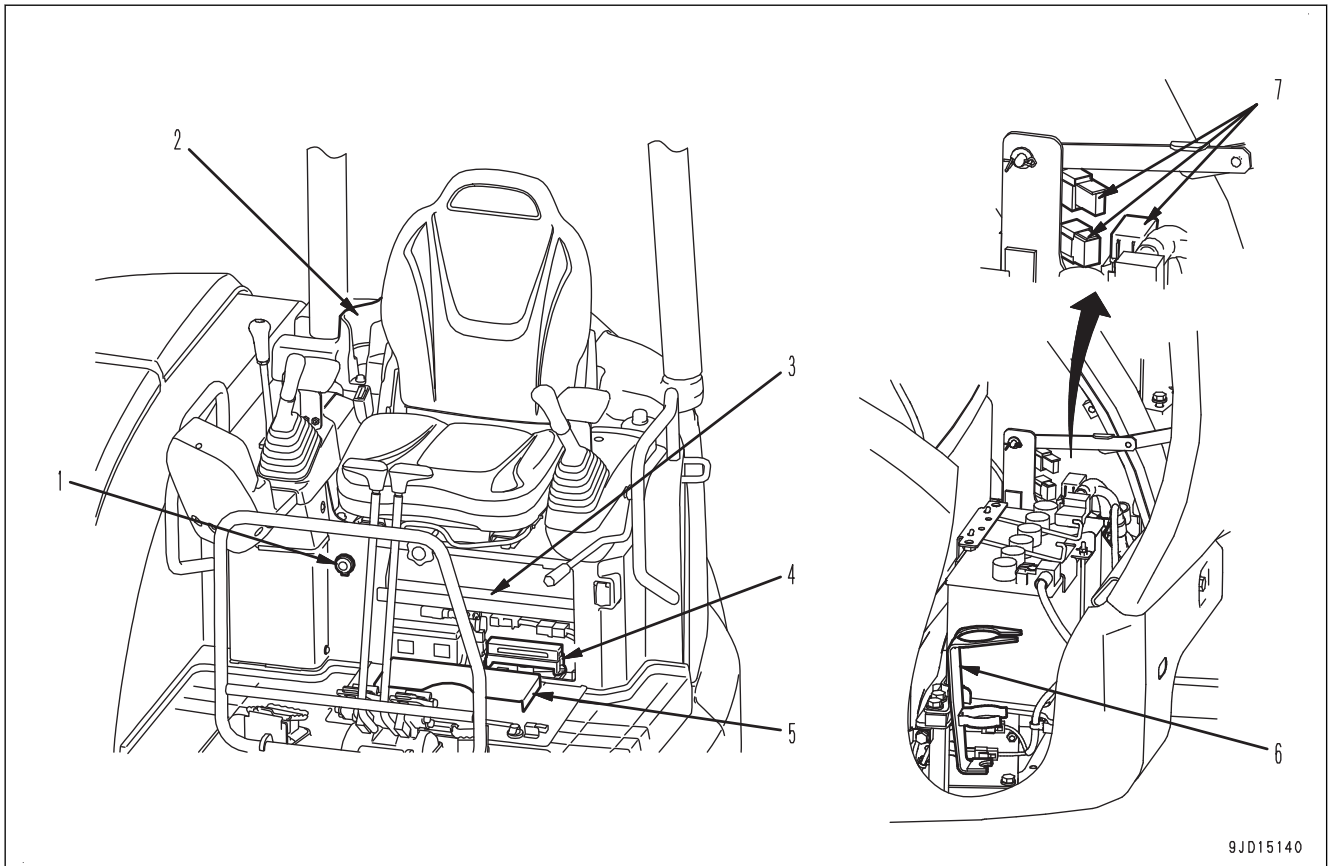
OTHER EQUIPMENT NAME**OTHER EQUIPMENT NAME: CANOPY SPEC**

9JD15140

(1) Auxiliary electric power

(2) Cup holder

(3) Toolbox

(4) Fuse

(5) Operation and Maintenance Manual pocket

(6) Grease pump holder

(7) Fusible link

OTHER EQUIPMENT NAME: CAB SPEC

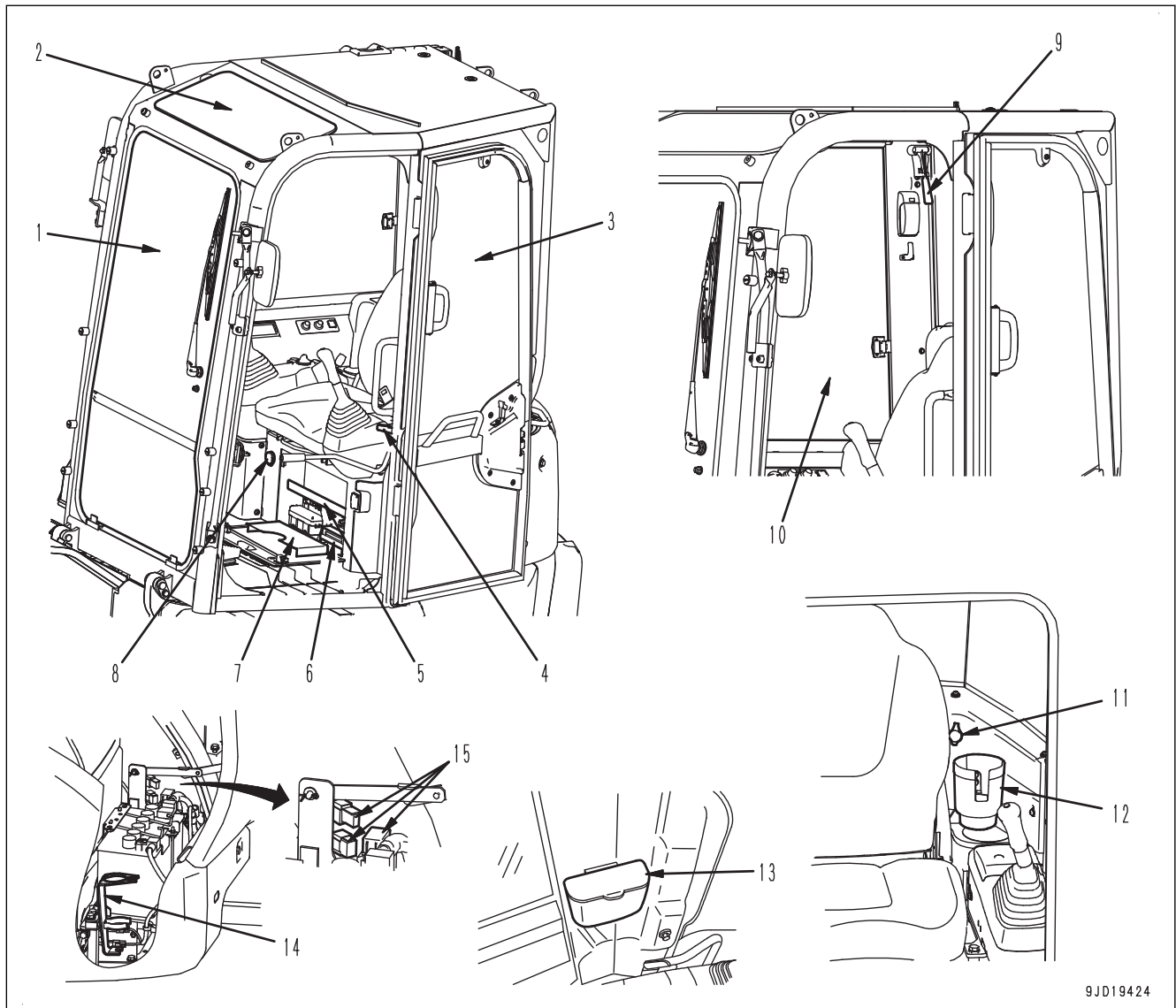

9JD19424

- (1) Front window
- (2) Ceiling window
- (3) Door
- (4) Door lock release lever
- (5) Toolbox
- (6) Fuse
- (7) Operation and Maintenance Manual pocket
- (8) Power supply outlet
- (9) Emergency escape hammer
- (10) Small slide window
- (11) AUX (if equipped)
- (12) Cup holder
- (13) Ashtray (if equipped)
- (14) Grease pump holder
- (15) Fusible link

EXPLANATION OF COMPONENTS

The following is an explanation of devices necessary to operate the machine.

To perform suitable operations correctly and safely, it is important to completely understand methods of operating the equipment, and the meanings of the displays.

EXPLANATION OF MACHINE MONITOR EQUIPMENT

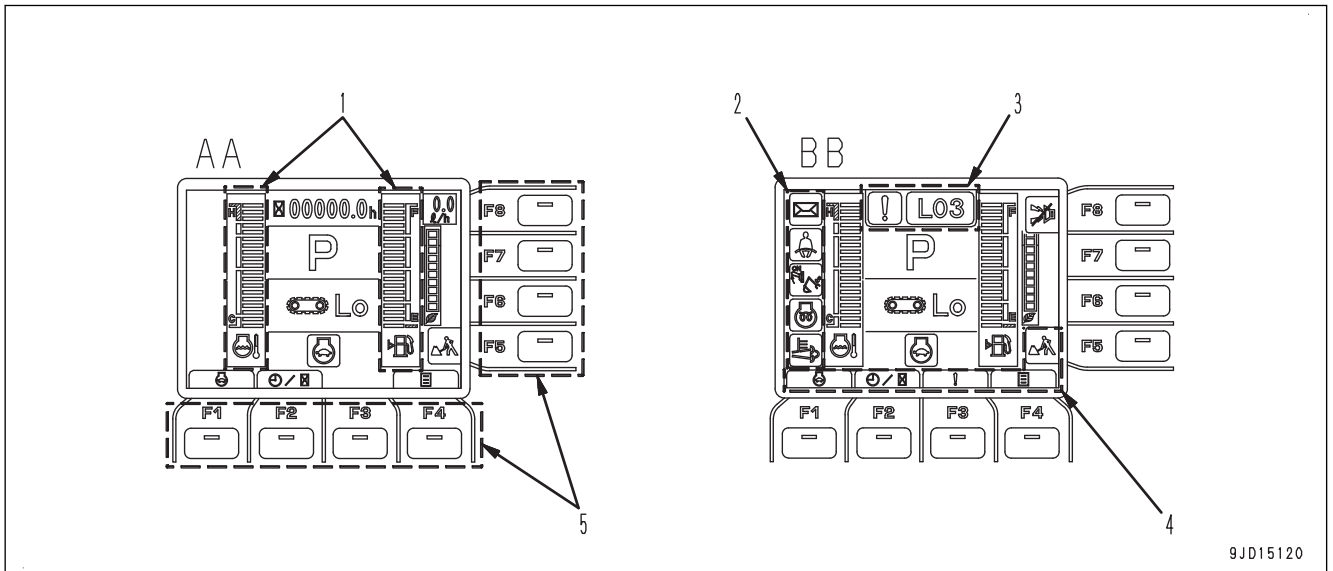

AA: Standard screen, BB: Warning or Error screen

- (1) Gauge display
- (2) Pilot display
- (3) Warning display

- (4) Guidance icon display
- (5) Function switches ("F1" to "F8")

BASIC OPERATION OF MACHINE MONITOR

BASIC OPERATION OF MACHINE MONITOR WHEN STARTING ENGINE IN NORMAL SITUATION

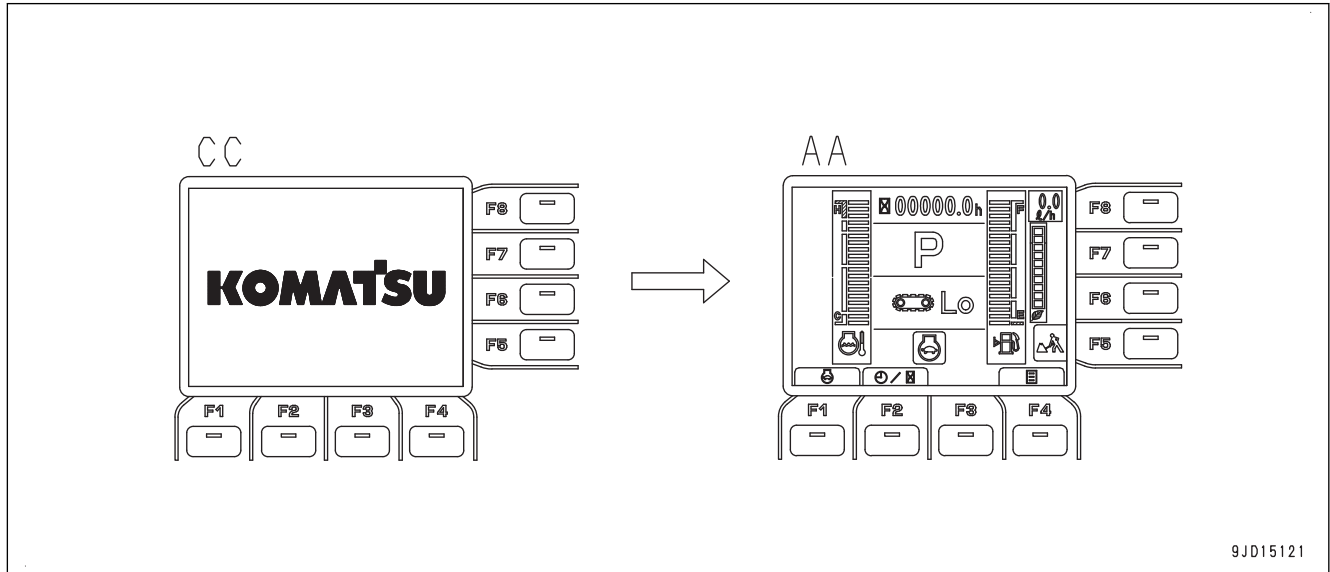

9JD15121

- When the starting switch is turned to ON position, opening screen CC is displayed.
- After opening screen CC is displayed for 2 seconds, the screen changes to standard screen AA.

REMARK

At starting of the engine, battery voltage may drop abruptly depending on the ambient temperature or battery condition, and the machine monitor may restart, but it is not a trouble.

BASIC OPERATION OF MACHINE MONITOR WHEN STARTING ENGINE WHILE ENGINE SHUTDOWN SECONDARY SWITCH IS ON

While the engine shutdown secondary switch is in ON (engine is stopped) position (a), when the starting switch is turned to ON position, the screen shown in the figure is displayed and engine does not start.

If the engine shutdown secondary switch is turned to OFF (normal) position (b), the machine monitor switches to the standard screen, and you can start the engine by turning the starting switch to START position.

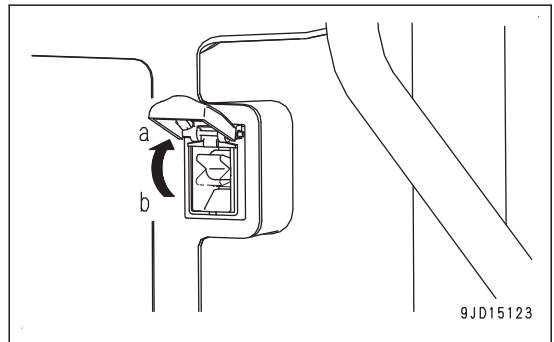

9JD15123

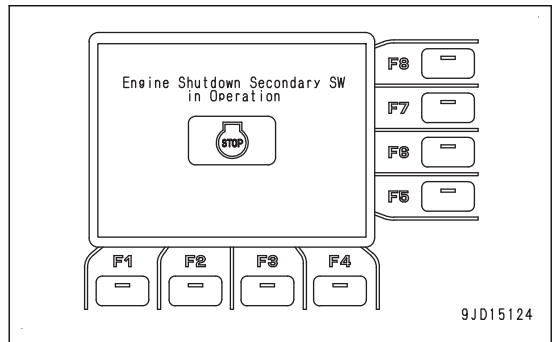

9JD15124

BASIC OPERATION OF MACHINE MONITOR WHEN STOPPING ENGINE IN NORMAL SITUATION

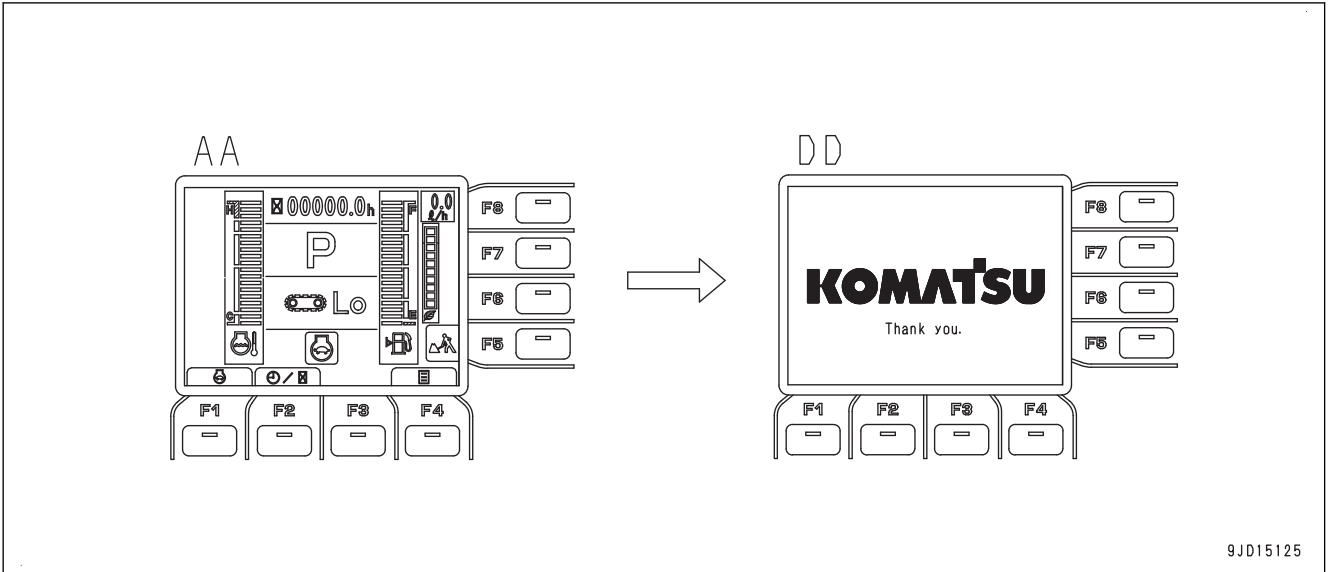

9JD15125

When the starting switch is turned to OFF position, end screen DD is displayed for 5 seconds, and then the screen goes out.

End screen when any message has been received

If there is any message from your Komatsu distributor, it is displayed on the end screen.

In this case, turn the starting switch to ON position to re-check the message, and if the message is requesting a response, make a reply to it.

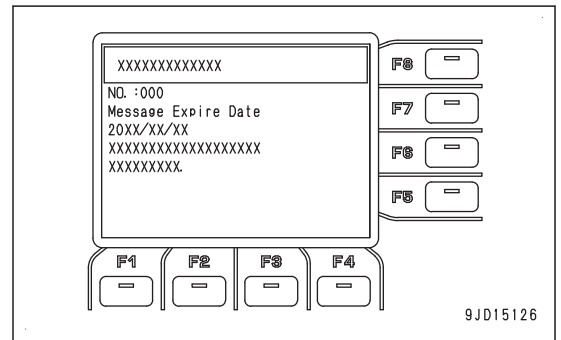

9JD15126

BASIC OPERATION OF MACHINE MONITOR WHEN STARTING ENGINE IN AB-NORMAL SITUATION

If there is maintenance time warning when starting the engine

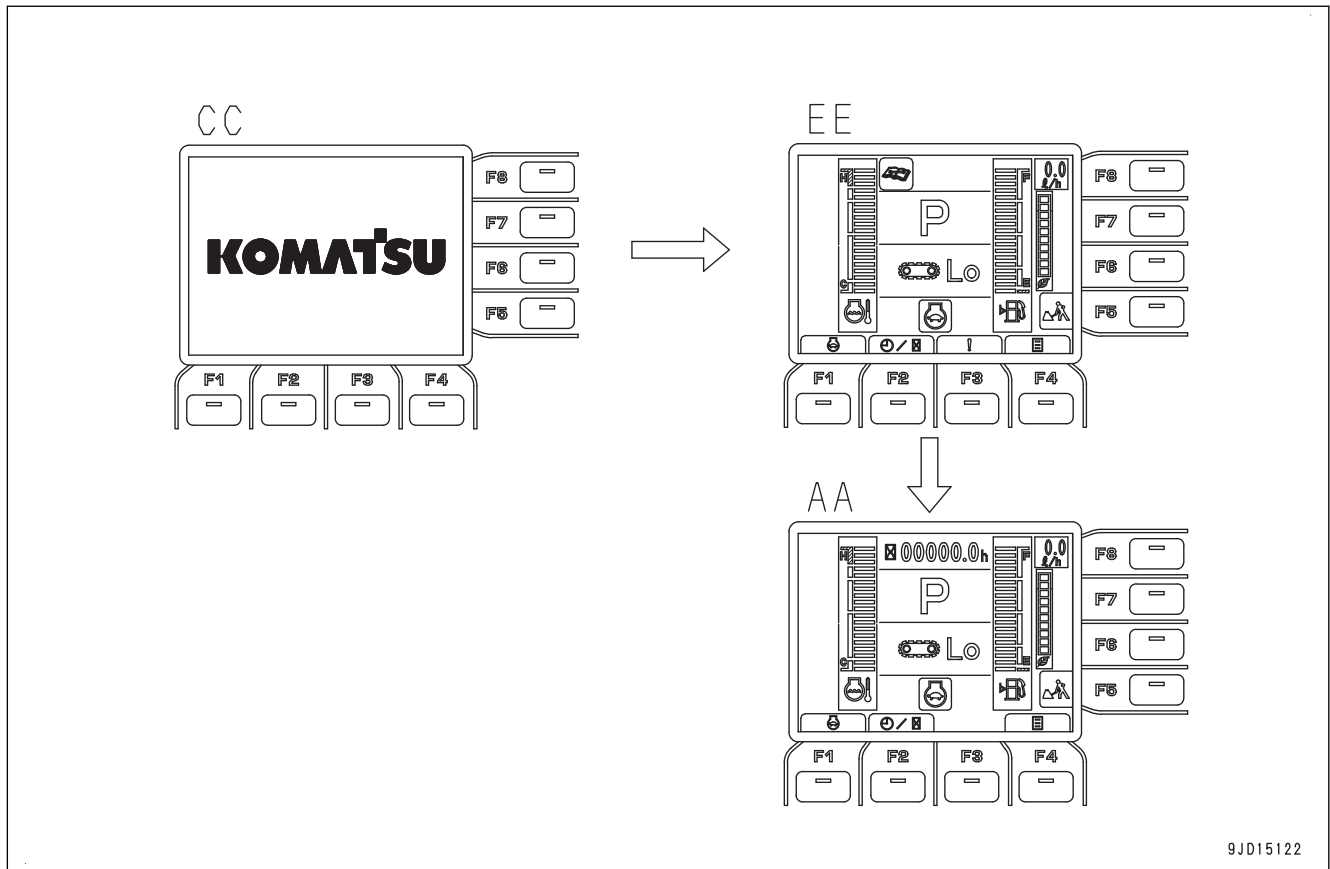

- If there is any maintenance time warning when starting the engine, opening screen CC changes to maintenance time warning screen EE.
- After displaying opening screen CC for 2 seconds, the screen changes to maintenance time warning screen EE.
- After displaying maintenance time warning screen EE for 30 seconds, the screen changes to standard screen AA.

If there is an abnormality when starting the engine

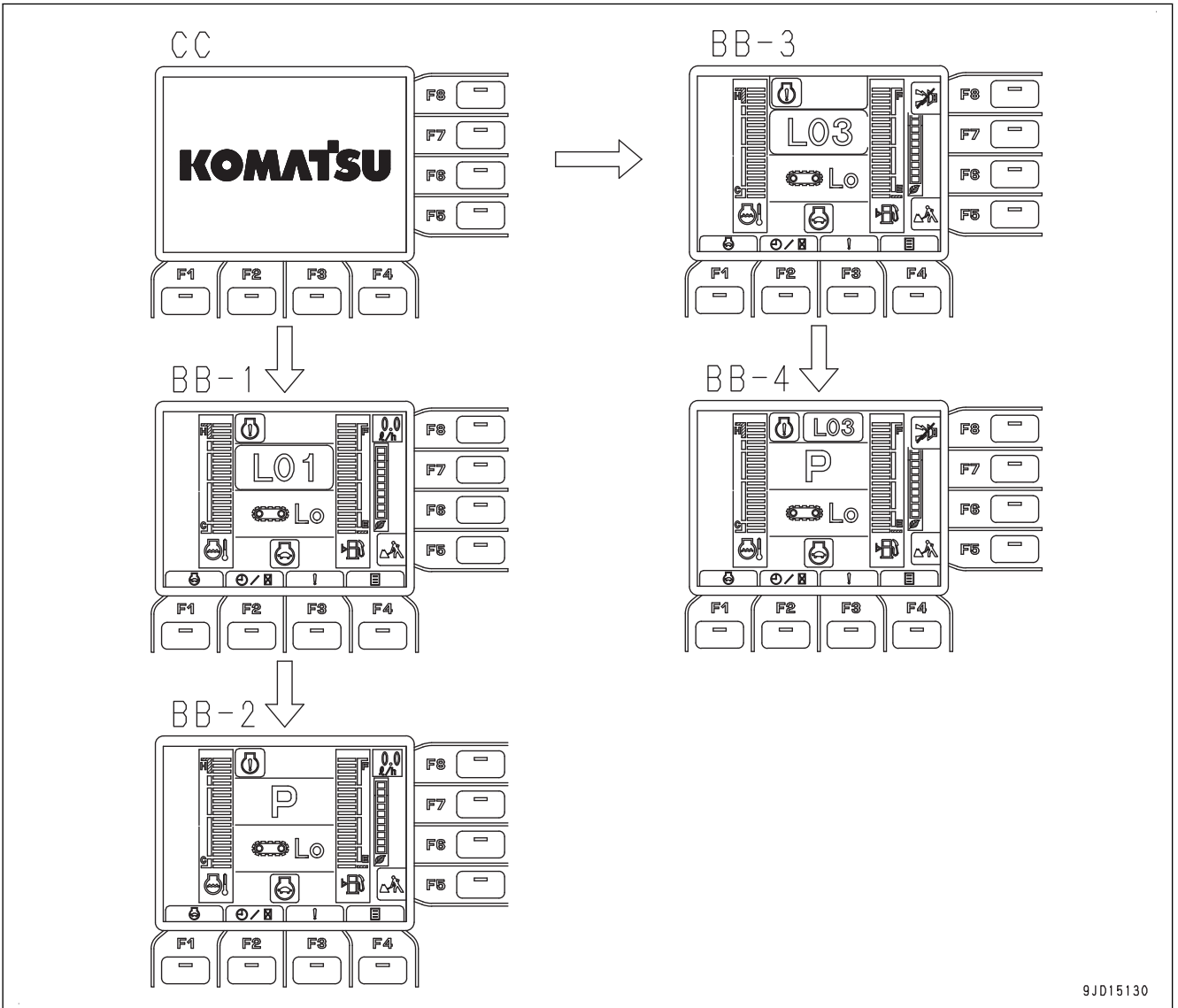

9JD15130

- If there is any abnormality when starting the engine, opening screen CC changes to warning screen BB.
- After opening screen CC is displayed for 2 seconds, the screen changes to warning screen BB.
- After warning screen BB-(1) and (3) are displayed for 2 seconds, the screen automatically changes to warning screen BB-(2).

If there is any error existing, “!” is displayed on top of switch “F3”.

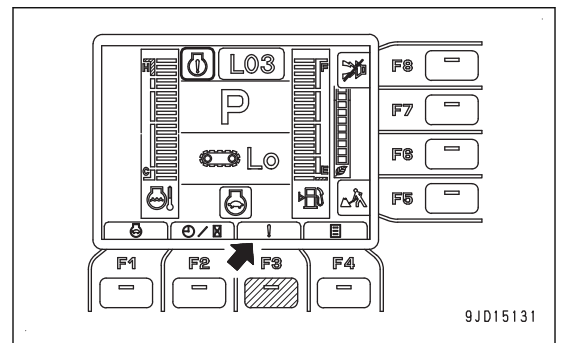

9JD15131

For checking the details of error, press function switch “F3”, and then existing error list screen is displayed.

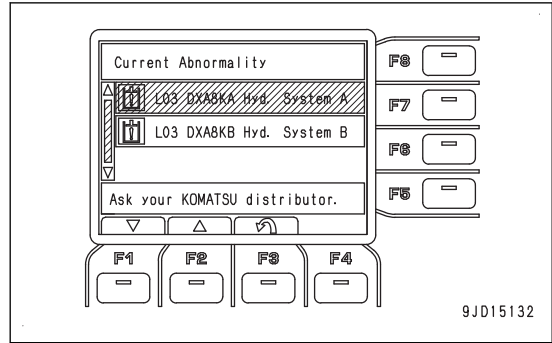

BASIC OPERATION OF MACHINE MONITOR WHEN TROUBLE OCCURS WHILE OPERATING MACHINE

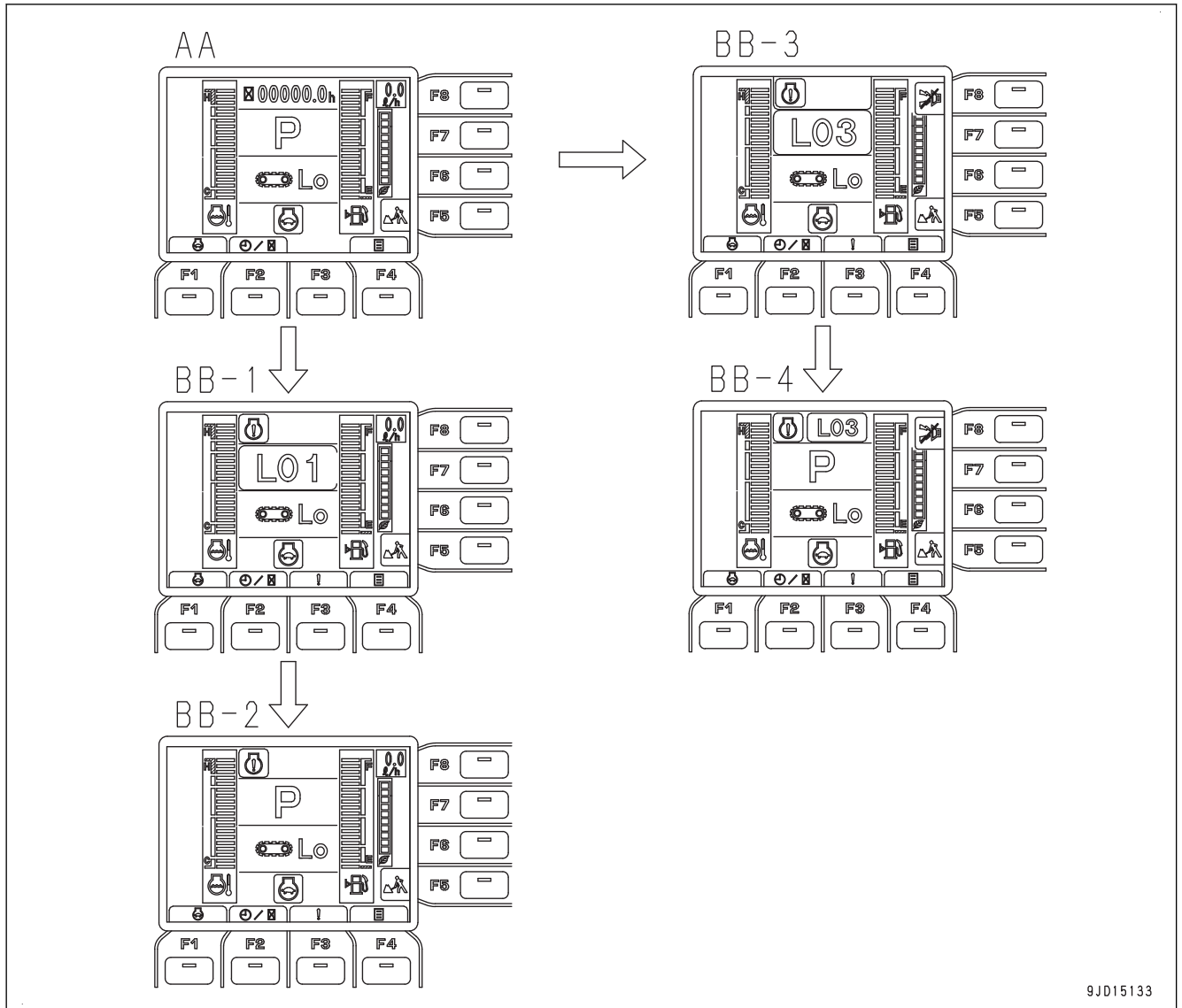

9JD15133

- If any abnormality occurs during operation, standard screen AA changes to warning screen BB.
- After warning screen BB-(1) and (3) are displayed for 2 seconds, the screen automatically changes to warning screen BB-(2) and (4).

If there is any error existing, "!" is displayed on top of switch "F3".

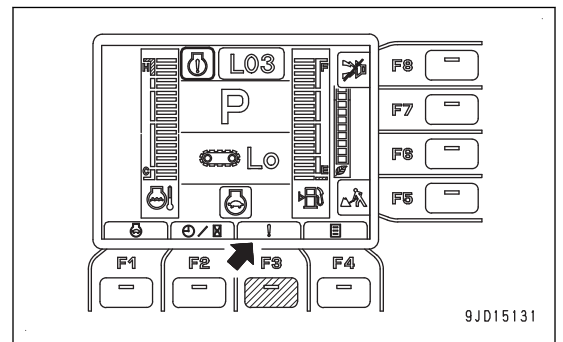

9JD15131

For checking the details of error, press function switch “F3”, and then existing error list screen is displayed.

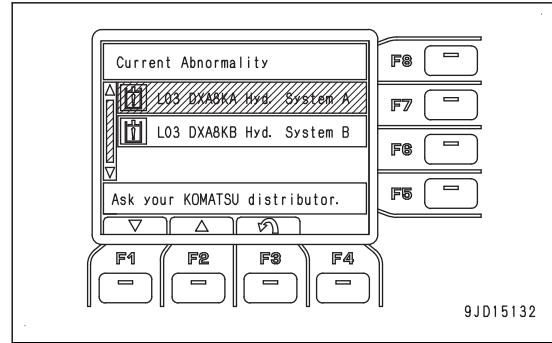

WARNING DISPLAY

NOTICE

Appearance of any of action levels “L01” to “L04” on the machine monitor indicates presence of an abnormality of the machine.

Take appropriate actions following the list of action level displays and required actions.

The caution lamp that lights up in red when an action level is displayed warns operator to stop the machine urgently, stop or pause the current operation.

If no action is taken, the machine can be seriously affected. Take necessary actions immediately.

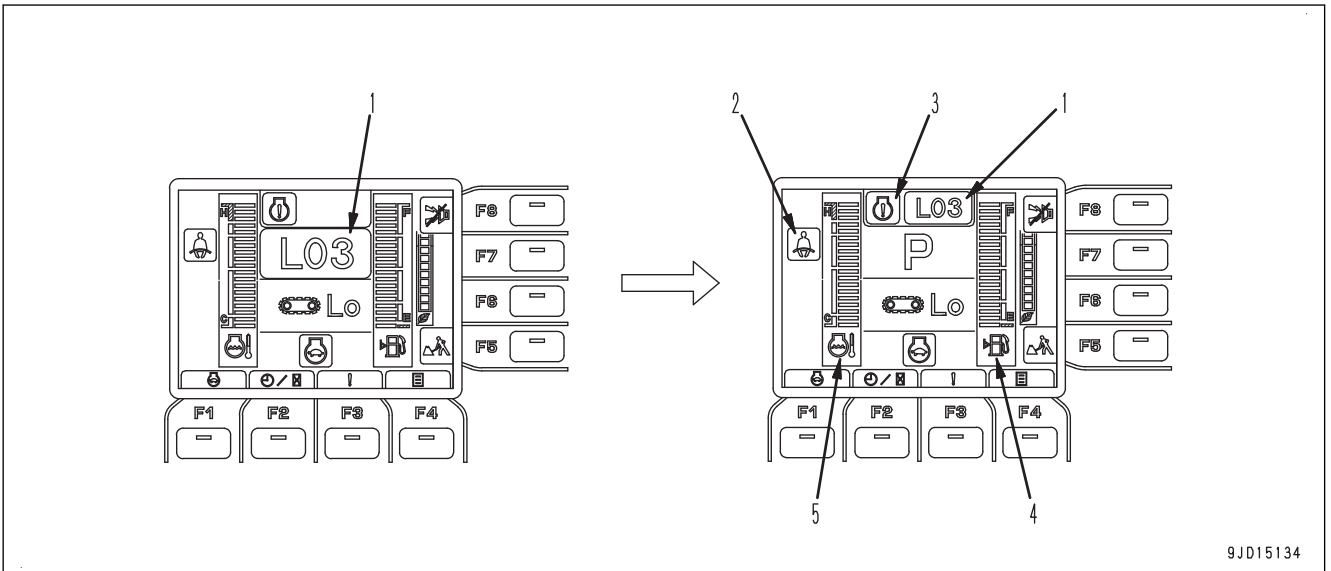

(1) Action level display

(2) Seat belt caution lamp

(3) Caution lamp

Standard screen

When 1 type of caution is generated, it is displayed on caution lamp (3).

When 2 types or more of caution are generated, they are displayed on caution lamp (3) alternately at intervals of 2 seconds.

9JD15134

(4) Fuel level caution lamp

(5) Engine coolant temperature caution lamp

ACTION LEVEL DISPLAY

Action level display indicates the degree of urgency of the abnormality currently generated on the machine by “L01” to “L04”.

The larger the number in the table is, the more serious effects the abnormality may have on the machine if it is left with no action.

If the machine monitor indicates an action level, check the message displayed on the machine monitor.

By pressing function switch “F3” on the standard screen while the action level is displayed, the list of the current abnormality is displayed.

Take appropriate actions by following the message displayed on the machine monitor.

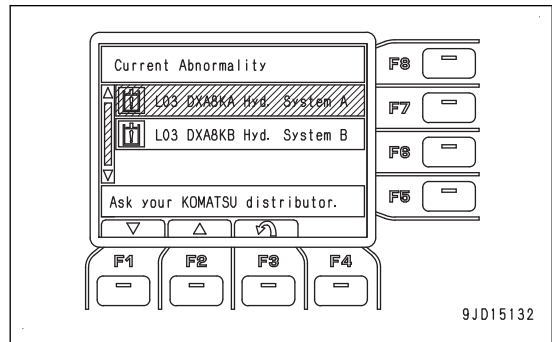
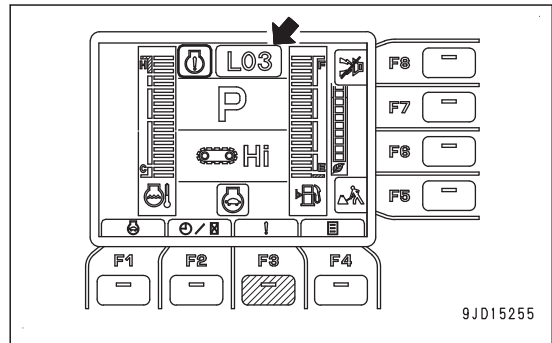

List of action level displays and required actions









Degree of urgency	Action level	Buzzer	Caution lamp	Required action
High ↑ ↓ Low	L04	Sounds continuously	Lights up in red	Stop the machine immediately and ask your Komatsu distributor for the inspection and maintenance.
	L03	Sounds intermittently	Lights up in red	Stop the operation, move the machine to a safe place, and then ask your Komatsu distributor for the inspection and maintenance.
	L02	Sounds intermittently	Lights up in red	Stop the operation, and run the engine at medium speed with no load or stop it. If the condition is not improved, ask your Komatsu distributor for the inspection and maintenance.
	L01	Does not sound	Lights up in yellow	Some functions may be restricted for use, but the machine can operate. When you finish the operation, always perform the inspection and maintenance. Ask your Komatsu distributor for the inspection and maintenance as needed.

CAUTION LAMP LIST

NOTICE

- These caution lamps do not guarantee the condition of the machine. Do not simply rely on the caution lamp when performing check before starting (start-up inspection). Always get off the machine and check each item directly.
- When the caution lamp is displayed in red, if no action is taken, the machine can be seriously affected. Take the action immediately.
- The engine output or engine speed is limited and the machine operation speed may become slow, depending on the contents of the warning.

Caution lamps and display colors

Symbol	Type of caution lamp	Display color/Machine condition (Action level)			
		Red	Yellow	White	Blue
 9JD16301	Engine coolant temperature caution lamp	High temperature (L02)	-	Low temperature	Normal
 9JD16302	Fuel level caution lamp	Low level	-	-	Normal
 9JC01169	System caution lamp	Abnormal (L04/L03)	Abnormal (L01)	-	-
 9JC01171	Hydraulic system caution lamp	Abnormal (L04/L03)	Abnormal (L01)	-	-
 9JC01172	KDPF system caution lamp	Abnormal (L04/L03)	Abnormal (L01)	-	-
 9JC01173	KDPF soot accumulation caution lamp	Abnormal (L03)	Accumulated (L01)	-	-
 9JC01170	Engine system caution lamp	Abnormal (L04/L03)	Abnormal (L01)	-	-
 9JC01164	Engine oil pressure caution lamp	Low oil pressure (L03)	-	-	-
 9JC01163	Charge level caution lamp	Abnormal (L03)	-	-	-
 9JC01168	Maintenance time caution lamp	Due time is over	Notice	-	-
 ZZ000489	Seat belt caution lamp	Seat belt is not fastened	-	-	-

For the meaning of each caution lamp and the action to take for it, see the section of each caution lamp.

CURRENT ABNORMALITY LIST DISPLAY

If there is any abnormality currently generated, “!” is displayed on top of function switch “F3”.

While “!” is displayed, if you press function switch “F3”, monitor display screen is shifted to “Current Abnormality” screen.

Take appropriate remedies according to the message displayed on the monitor.

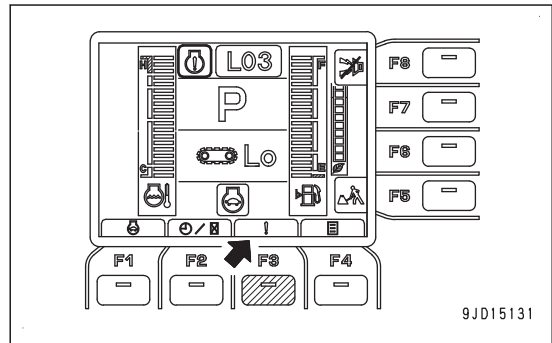

Operation on “Current Abnormality” screen

On “Current Abnormality” screen, you can perform the following operations with function switches “F1”, “F2”, and “F3”.

Function switch “F1”

Displays the next page. When on the last page, it displays the first page.

Function switch “F2”

Displays the previous page. When on the first page, it displays the last page.

Function switch “F3”

Return to the standard screen.

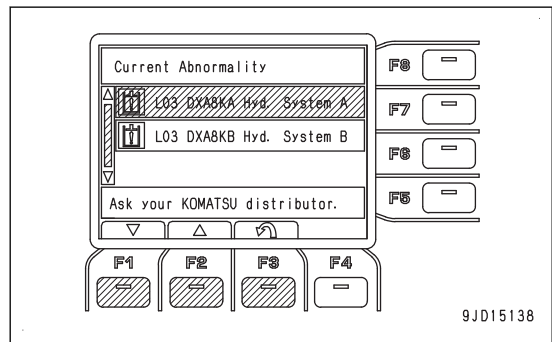

ENGINE COOLANT TEMPERATURE CAUTION LAMP

Engine coolant temperature caution lamp warns about states caused by engine coolant temperature.

When abnormal

The caution lamp lights up in red, and action level “L02” is displayed.

The engine coolant temperature is abnormally high.

While this lamp is lit, the overheat prevention system is automatically actuated and the engine speed drops.

Stop the machine operations and run the engine at low idle until the caution lamp changes to the normal display color (blue) at a correct temperature.

When temperature is low

The caution lamp lights up in white.

The engine coolant temperature is low.

The engine needs to be warmed up.

Perform the warm-up operation for the engine until the caution lamp changes to the normal display color (blue) at the correct temperature.

When temperature is correct

The caution lamp lights up in blue.

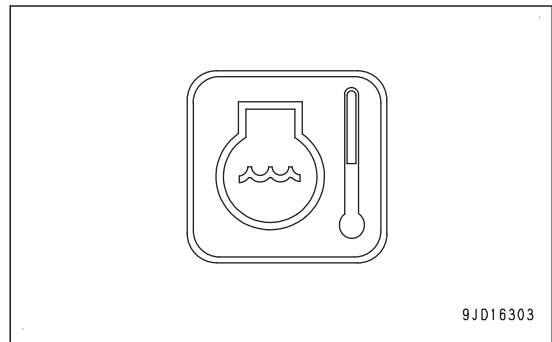

FUEL LEVEL CAUTION LAMP

The fuel level caution lamp warns about low level of remaining fuel.

When fuel level is low

The caution lamp lights up in red.

The remaining fuel level is 14 ℓ or less {3.7 U.S.Gal or less} .

Add fuel as soon as possible.

When normal

The caution lamp lights up in blue.

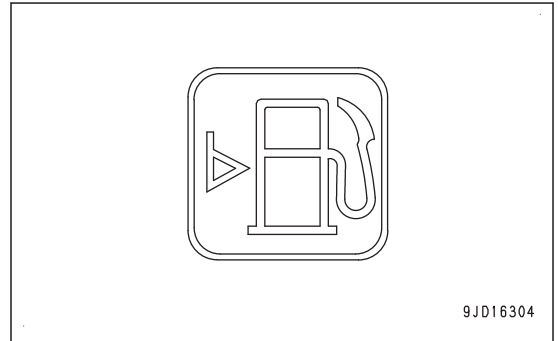

SYSTEM CAUTION LAMP

The system caution lamp warns about abnormality in the machine system, including the sensors.

When action level “L04” is displayed

The caution lamp lights up in red and the alarm buzzer sounds continuously.

Stop the machine immediately and ask your Komatsu distributor for inspection and maintenance.

When action level “L03” is displayed

The caution lamp lights up in red and the alarm buzzer sounds intermittently.

Stop the operation and move the machine to a safe place, then ask your Komatsu distributor for inspection and maintenance.

When action level “L01” is displayed

The caution lamp lights up in yellow.

Some functions may be restricted for use, but the machine can operate.

When you finish the operation, always perform the inspection and maintenance.

Ask your Komatsu distributor for inspection and maintenance as needed.

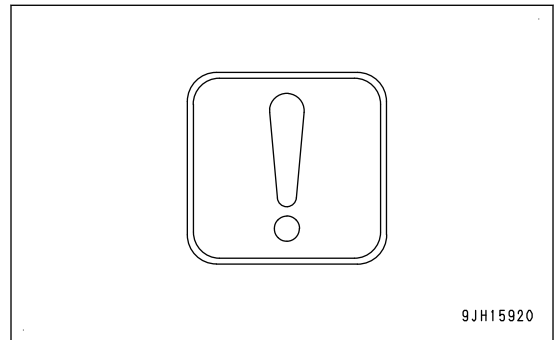

HYDRAULIC SYSTEM CAUTION LAMP

The hydraulic system caution lamp warns about abnormality in the hydraulic system.

When action level “L04” is displayed

The caution lamp lights up in red and the alarm buzzer sounds continuously.

Stop the machine immediately and ask your Komatsu distributor for inspection and maintenance.

When action level “L03” is displayed

The caution lamp lights up in red and the alarm buzzer sounds intermittently.

Stop the operation and move the machine to a safe place, then ask your Komatsu distributor for inspection and maintenance.

When action level “L01” is displayed

The caution lamp lights up in yellow.

Some functions may be restricted for use, but the machine can operate.

When you finish the operation, always perform the inspection and maintenance.

Ask your Komatsu distributor for inspection and maintenance as needed.

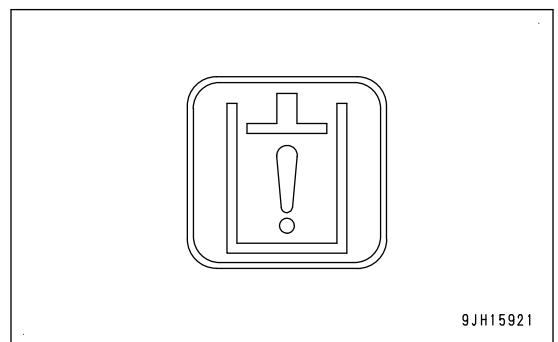

KDPF SYSTEM CAUTION LAMP

The KDPF system caution lamp warns about abnormality in the KDPF system.

When action level “L04” is displayed

The caution lamp lights up in red and the alarm buzzer sounds continuously.

Stop the machine immediately and ask your Komatsu distributor for inspection and maintenance.

When action level “L03” is displayed

The caution lamp lights up in red and the alarm buzzer sounds intermittently.

Stop the operation, move the machine to a safe place, and then ask your Komatsu distributor for the inspection and maintenance.

When action level “L01” is displayed

The caution lamp lights up in yellow.

Some functions may be restricted for use, but the machine can operate.

When you finish the operation, always perform the inspection and maintenance.

Ask your Komatsu distributor for the inspection and maintenance as needed.

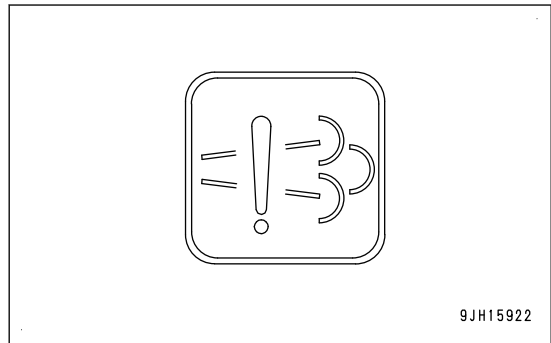

KDPF SOOT ACCUMULATION CAUTION LAMP

The KDPF soot accumulation caution lamp warns that soot is accumulated in KDPF or the filtering function of KDPF has lowered abnormally.

To cancel the alarm, perform the manual stationary regeneration of KDPF.

When abnormal

The caution lamp lights up in red, and action level “L03” is displayed.

The alarm buzzer sounds intermittently.

Large accumulation of soot in KDPF or a system failure such as lowering of the filtering function of KDPF occurred.

Urgent remedy is required.

Move the machine to a safe place immediately and perform the manual stationary regeneration.

The manual stationary regeneration may start automatically to protect KDPF system.

When soot is accumulated

The caution lamp lights up in yellow, and action level “L01” is displayed.

Much soot is accumulated in KDPF, however, the operation can be performed.

After the operation is finished, move the machine to a safe place and perform manual stationary regeneration.

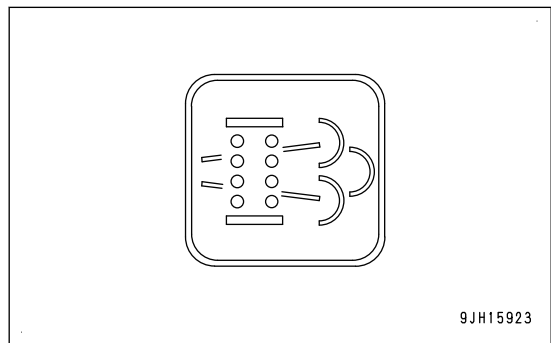

ENGINE SYSTEM CAUTION LAMP

CAUTION

If the operation is continued while the red caution lamp is lit, accumulation and combustion of the soot in KDPF are accelerated, and consequently the temperature of KDPF and exhaust gas can increase high. Stop the engine immediately.

The engine system caution lamp warns about abnormality in the engine system.

When action level “L04” is displayed

The caution lamp lights up in red and the alarm buzzer sounds continuously.

Stop the machine immediately and ask your Komatsu distributor for inspection and maintenance.

When action level “L03” is displayed

The caution lamp lights up in red and the alarm buzzer sounds intermittently.

Stop the operation and move the machine to a safe place, then ask your Komatsu distributor for inspection and maintenance.

When action level “L01” is displayed

The caution lamp lights up in yellow.

Some functions may be restricted for use, but the machine can operate.

When you finish the operation, always have the inspection and maintenance performed.

Ask your Komatsu distributor for the inspection and maintenance as needed.

ENGINE OIL PRESSURE CAUTION LAMP

Engine oil pressure caution lamp warns about abnormality of engine lubricating oil pressure.

When oil pressure is low

The caution lamp lights up in red and indicates action level “L03”.

The alarm buzzer sounds intermittently.

Stop the operation and move the machine to a safe place, then ask your Komatsu distributor for inspection and maintenance.

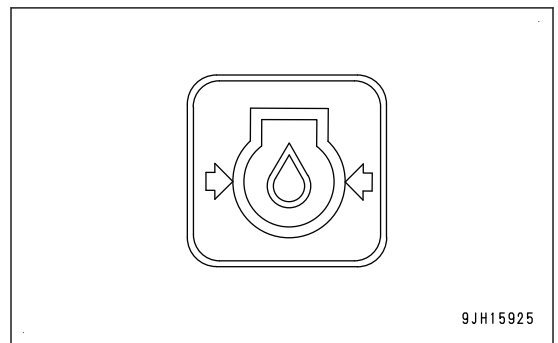
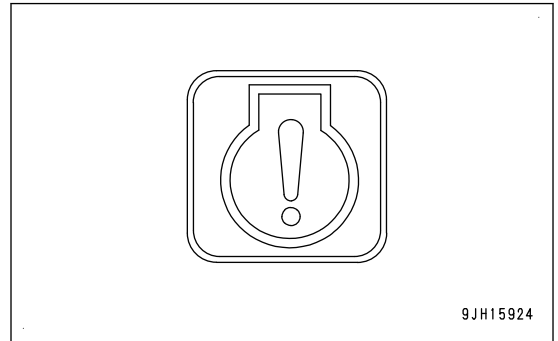

CHARGE LEVEL CAUTION LAMP

Charge level caution lamp warns about abnormality in the charging system while the engine is running.

When abnormal

The caution lamp lights up in red, and action level “L03” is displayed.

The alarm buzzer sounds intermittently.

Charging is not be performed normally while the engine is running.

Stop the engine, check the fan belt for damage, and then ask your Komatsu distributor for inspection and maintenance.

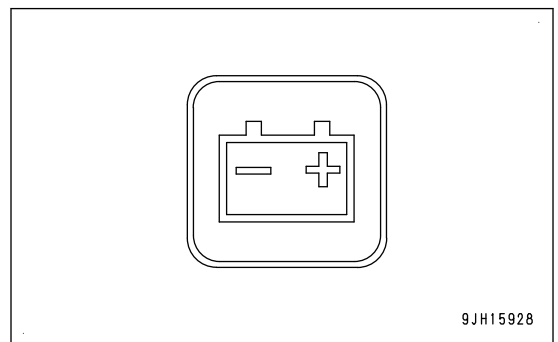

MAINTENANCE TIME CAUTION LAMP

Maintenance time caution lamp displays notices and alarms concerning maintenance time.

This lamp lights up when the starting switch is turned to ON position. It goes out after 30 seconds and the screen changes to the standard screen.

When the due time is over

The caution lamp lights up in red.

The maintenance time is over.

If no action is taken, the machine performance will become worse and the machine life will be shortened.

Perform necessary maintenance as soon as possible.

When giving the notice of the due time

The caution lamp lights up in yellow.

The maintenance time is approaching.

Prepare necessary parts for the maintenance.

REMARK

- You can check necessary maintenance items on "Maintenance" menu screen by pressing function switch "F4" on the maintenance time warning screen shown in the figure or on the standard screen.
- The lighting time of maintenance time notice (yellow) has been initially set to 30 hours, but it can be changed. To change the setting, ask your Komatsu distributor.
- For operations on "Maintenance" menu screen, see "MAINTENANCE SCREEN SETTING".

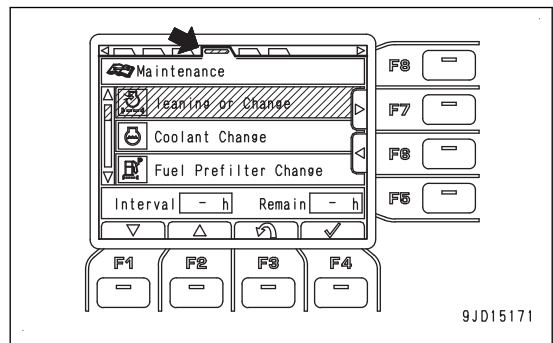
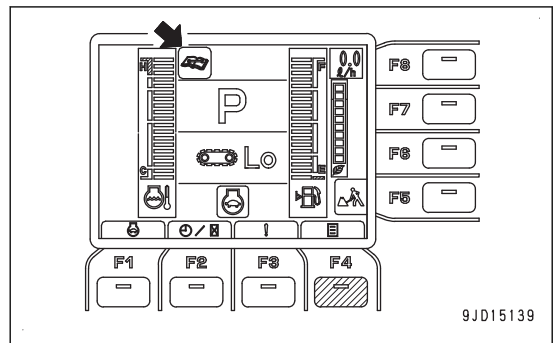
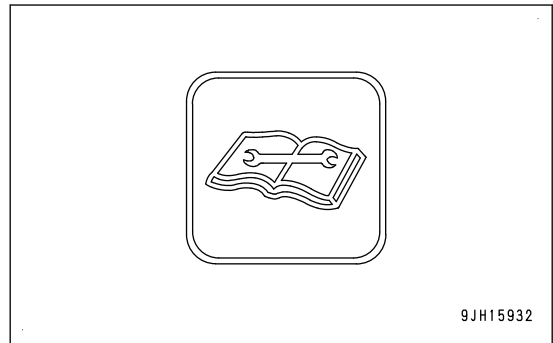

SEATBELT CAUTION LAMP

The seat belt caution lamp lights up when the seat belt is not fastened. It goes out when the seat belt is fastened.

Always fasten the seat belt while operating because there may be a possible danger.



PILOT DISPLAY AND GAUGE DISPLAY

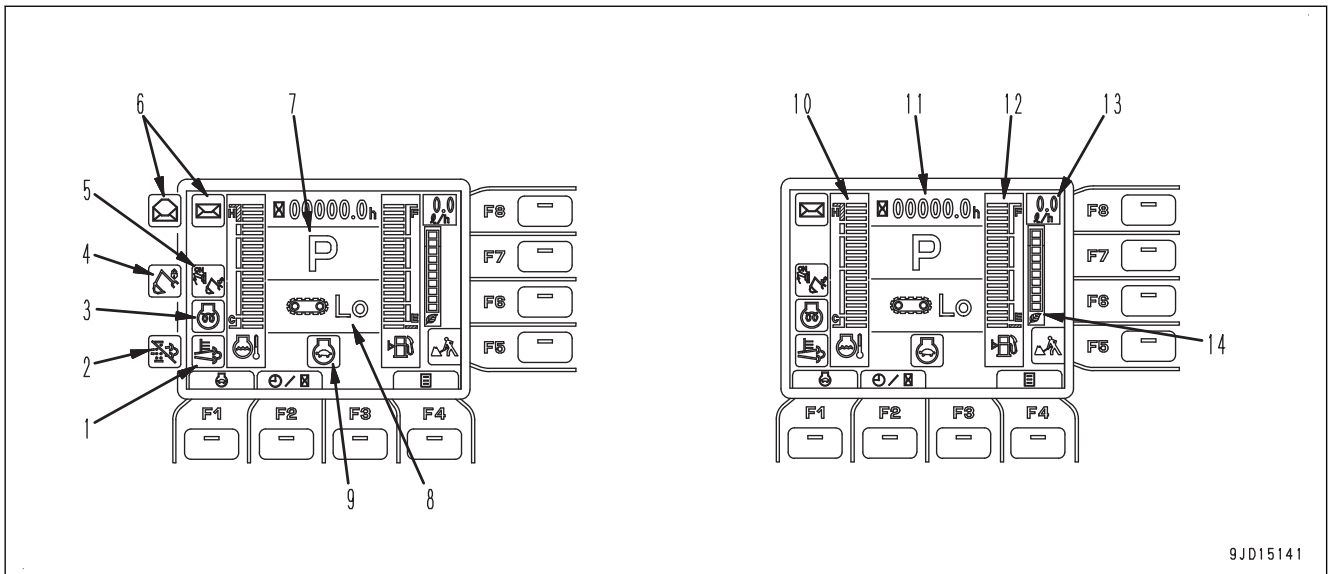

9JD15141

Pilot display

- (1) Aftertreatment devices regeneration pilot lamp
- (2) Aftertreatment devices regeneration disable pilot lamp
- (3) Preheating pilot lamp
- (4) Lock lever pilot lamp
- (5) Lock lever automatic lock cancel pilot lamp
- (6) Message display
- (7) Working mode display
- (8) Travel speed display
- (9) Auto-deceleration pilot lamp

Gauge display

- (10) Engine coolant temperature gauge
- (11) Service meter/clock
- (12) Fuel gauge
- (13) Fuel consumption gauge
- (14) ECO gauge

PILOT DISPLAY

The pilot display consists of the pilot lamps to check the actuation of each function.

When the starting switch is in ON position, the pilot lamps light up when the display items are functioning.

PREHEATING PILOT LAMP

The preheating pilot lamp is displayed while the engine is preheated before started.

When the temperature is low (in cold weather) and the automatic preheating function operates, the preheating pilot lamp lights up. It goes out after preheating is completed.

Automatic preheating is for a maximum of approximately 15 seconds.

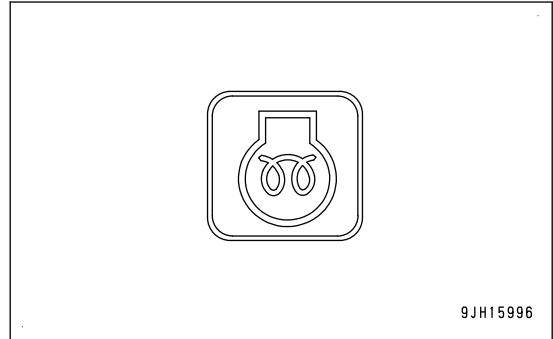

AUTO-DECELERATION PILOT LAMP

The auto-deceleration pilot lamp shows the setting of the auto-deceleration function either ON or OFF.

The pilot lamp display when the auto-deceleration switch is operated is as follows.

Auto-deceleration pilot lamp lights up

Auto-deceleration is turned on

Auto-deceleration pilot lamp goes out

Auto-deceleration is turned off

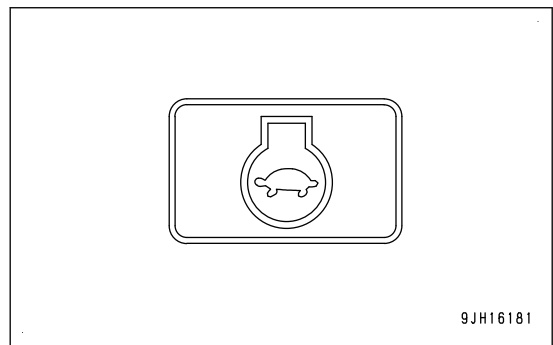

WORKING MODE DISPLAY

The working mode display shows the setting of the working mode.

The working mode display is as follows.

“P”

P mode (For heavy-duty operations)

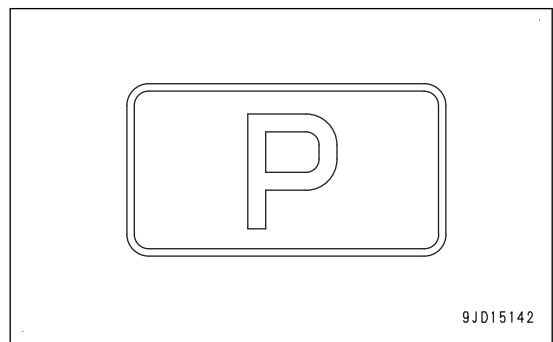

“E”

E mode (For operations with emphasis on fuel consumption)

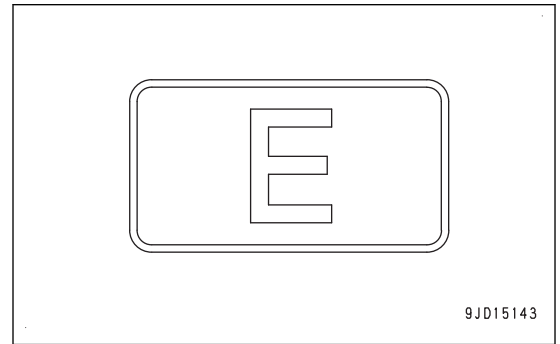
**“B”**

B mode (For breaker operations) (For machines ready for installation of attachments)

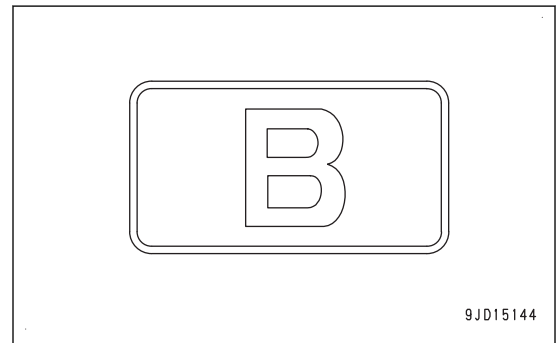
**“ATT/P”**

ATT/P mode (For operations of 2-way attachments like crusher)
(For machines ready for installation of attachment)

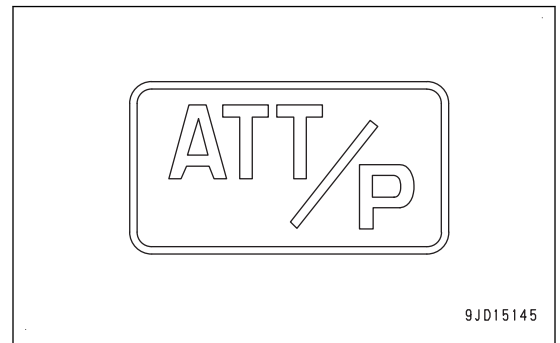
**“ATT/E”**

ATT/E mode (For operations emphasizing fuel consumption out of those of 2-way attachments like crusher) (For machines ready for installation of attachment)



TRAVEL SPEED DISPLAY

On the travel speed display, the selected travel mode is displayed.

“Lo”

Low-speed travel

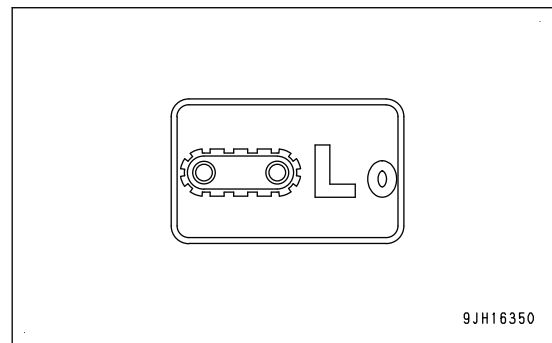

“Hi”

High-speed travel

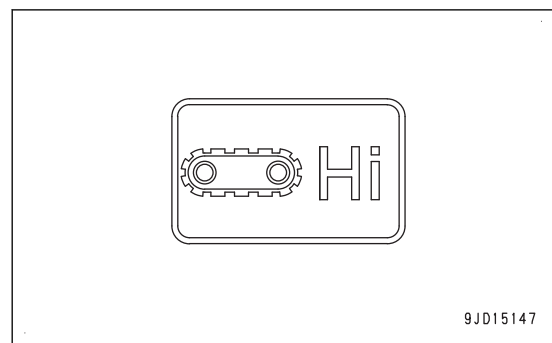

REMARK

Each time the travel mode is switched by the travel speed selector switch, it lights up in yellow at the center of the monitor display, and 2 seconds later, it lights up in blue again.

MESSAGE DISPLAY

The message display lights up when there is a message from Komatsu.

To read the message, see "CHECK MESSAGE".

Lights up in green

There is an unread message.

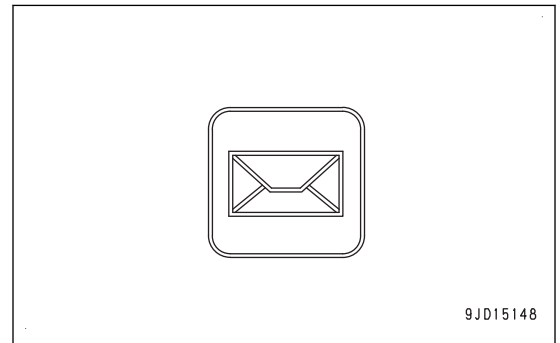

Lights up in blue

There is any read message to which no reply is made.

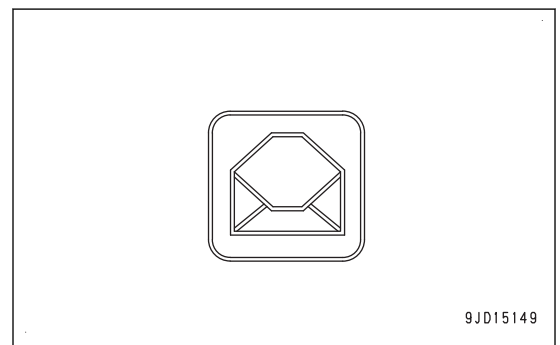

OFF

There is no message.

AFTERTREATMENT DEVICES REGENERATION PILOT LAMP

CAUTION

- Exhaust gas temperature may increase higher than the previous models during the aftertreatment devices regeneration.
Stay away from the exhaust pipe outlet to prevent yourself from getting burnt.
Keep combustible materials away from the exhaust pipe outlet to prevent a fire.
- When there are thatched houses, dry leaves or pieces of paper near the job site, set the system to the regeneration disable to prevent fire hazards due to highly heated exhaust gas during the after-treatment devices regeneration.

The aftertreatment devices regeneration pilot lamp lights up during regeneration of the exhaust gas aftertreatment devices. It goes out when the regeneration is completed.

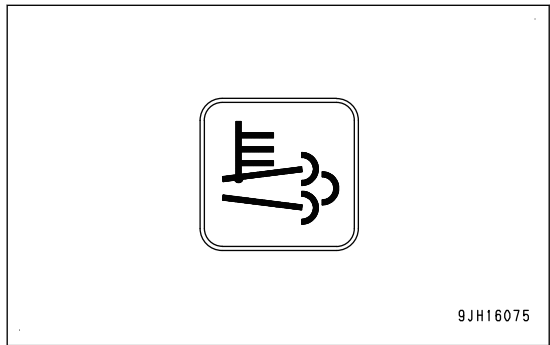

AFTERTREATMENT DEVICES REGENERATION DISABLE PILOT LAMP

Aftertreatment devices regeneration disable pilot lamp lights up when the aftertreatment devices are set not to be regenerated.

REMARK

Even if the aftertreatment devices regeneration is disabled, when the manual stationary regeneration is necessary, KDPF soot accumulation caution lamp lights up. If KDPF soot accumulation caution lamp lights up, cancel the regeneration disable setting and perform manual stationary regeneration.

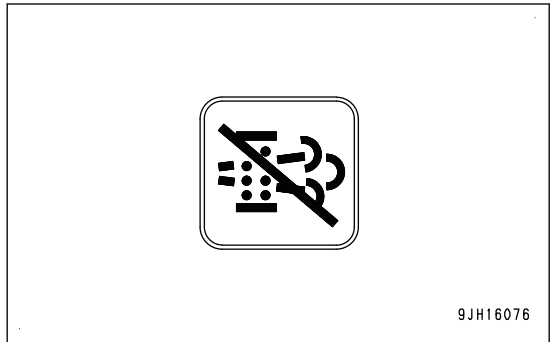

LOCK LEVER PILOT LAMP

The lock lever pilot lamp lights up when the lock lever is in LOCK position.

It goes out when the lock lever is set in FREE position.

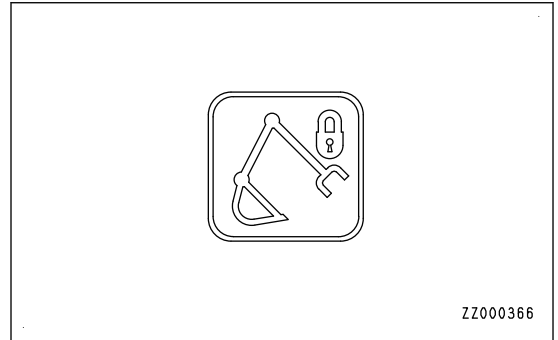

LOCK LEVER AUTOMATIC LOCK CANCEL PILOT LAMP

The lock lever automatic lock cancel pilot lamp lights up when the lock lever automatic lock cancel switch is set to CANCEL position.

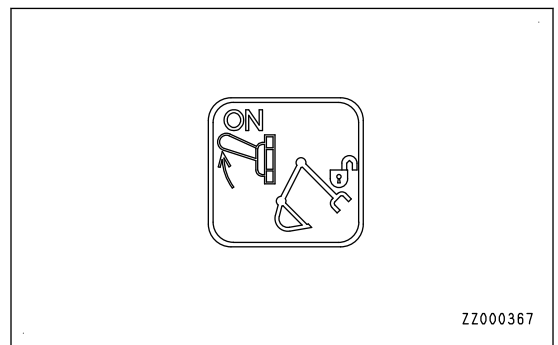

GAUGE DISPLAY

ENGINE COOLANT TEMPERATURE GAUGE

Engine coolant temperature gauge displays the engine coolant temperature in 19 graduations.

When the graduation of gauge is in green range (B) during operations, it is normal.

When the graduation of gauge is in red range (A) during operations, the overheat prevention system is actuated, and engine coolant temperature caution lamp (D) lights up in red.

Red range: Abnormal

The overheat prevention system is actuated.

Graduation of gauge lights up in red.

Engine coolant temperature caution lamp (D) lights up in red.

Green range: Normal

Graduation of gauge lights up in green.

Engine coolant temperature caution lamp (D) lights up in blue.

White range: Low temperature

Graduation of gauge lights up in white.

When the graduation of gauge goes beyond white range (C), color changes to green.

Engine coolant temperature caution lamp (D) lights up in white.

OFF: Abnormal

If communication error occurs or data is not received, the graduation of gauge goes out.

REMARK

- The overheat prevention system is actuated when the graduation of gauge goes in red range (A).
The engine runs at low idle.
Engine coolant temperature caution lamp (D) lights up in red.
The alarm buzzer sounds.
It keeps sounding until the graduation of gauge goes in green range (B).
- When starting the engine, if the engine coolant temperature gauge is in white range (C) and engine coolant temperature caution lamp (D) lights up in white, the engine coolant temperature is low. Accordingly, perform the warm-up operation.

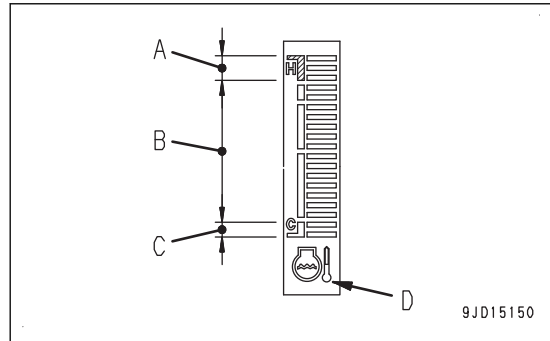

9JD15150

FUEL GAUGE

Fuel gauge displays the fuel level in 19 graduations.

When the graduation of gauge is in green range (A) during operations, it is normal.

When the graduation of gauge goes in red range (B) during operations, the remaining fuel level is 14 ℓ or less {3.7 U.S.Gal or less} , so check the fuel level and add it.

(A) Green range: Normal

The remaining fuel level is above 14 ℓ {above 3.7 U.S.Gal} .

Fuel level caution lamp (C) lights up in blue.

(B) Red range: The remaining fuel level is low

The remaining fuel level is 14 ℓ or less {3.7 U.S.Gal or less} .

Fuel level caution lamp (C) lights up in red.

OFF: Abnormal

If communication error occurs or data is not received, the graduation of gauge goes out.

REMARK

- The graduation of gauge may not indicate correctly for a short time after the starting switch is turned to ON position, but this is not an abnormality.
- The graduation of gauge may not indicate correctly for a short time when the machine is operated on a slope or it is stopped, but this is not an abnormality.

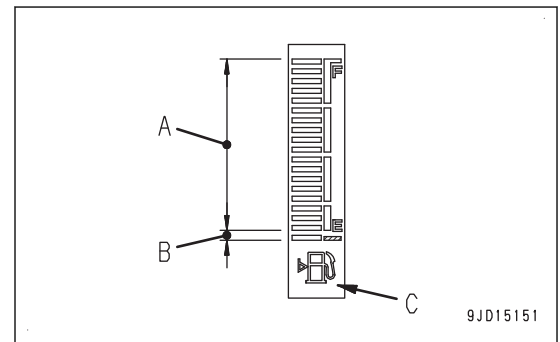

SERVICE METER / CLOCK

The service meter/clock shows the total hours of operation of the machine or the present time.

When the engine is running, the service meter advances even if the machine is not moving.

The service meter advances 0.1 every 6 operation minutes, regardless of the engine speed.

- Service meter display

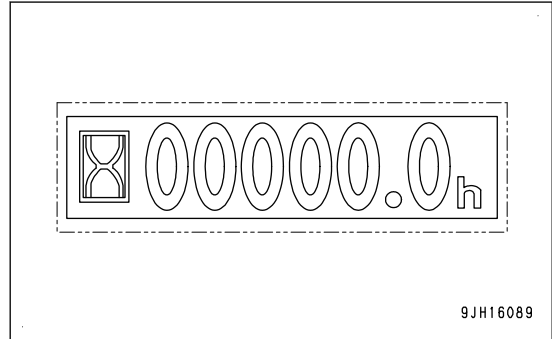

- Clock display (12-hour display)

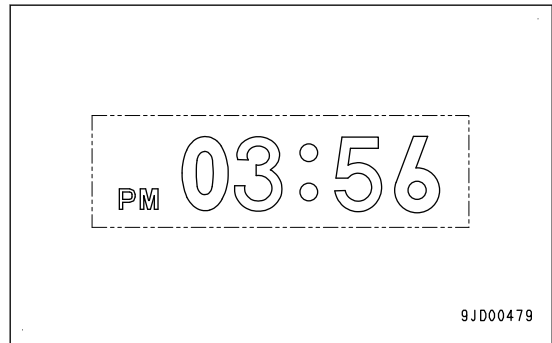

- Clock display (24-hour display)

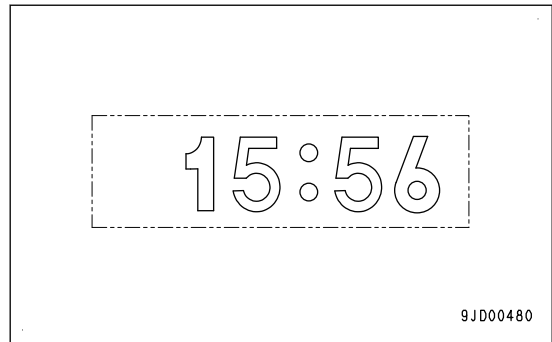

On the standard screen, if you press function switch “F2”, you can switch between the clock display and the service meter display alternately.

REMARK

- If the battery is disconnected for a long period for storage etc., the time information may be lost.
- Clock display (12-hour or 24-hour display is available)
- For the setting and correction of time, see “CLOCK ADJUSTMENT”.

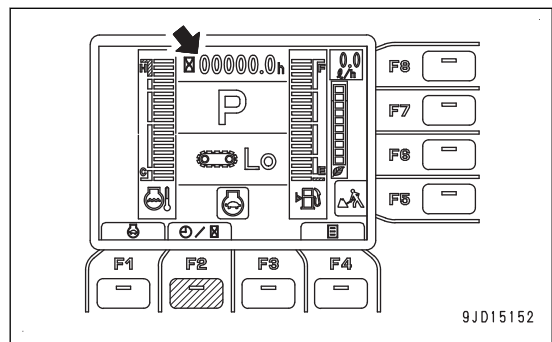

FUEL CONSUMPTION GAUGE

Fuel consumption gauge shows the average fuel consumption of the machine.

One day display

Displays the average fuel consumption of a day (from 0:00 a.m. of the day to 0:00 a.m. of the next day).

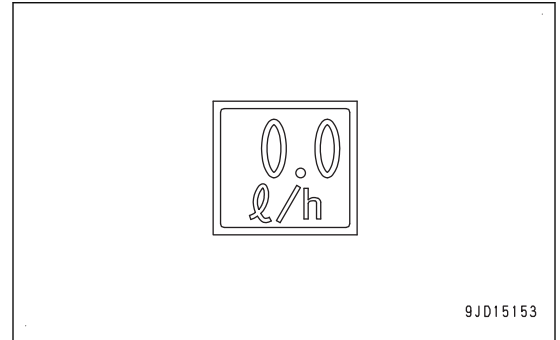

Split (under measurement) display

Displays the split fuel consumption under measurement.

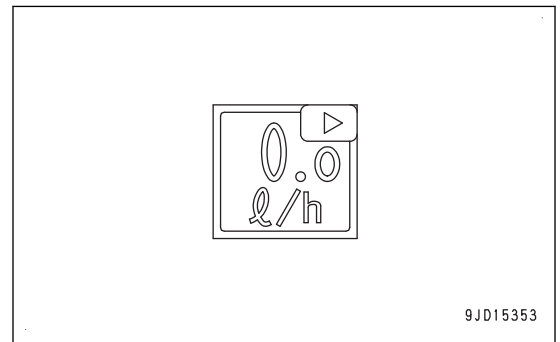

Split (measurement is stopped) display

Measurement of split fuel consumption is stopped.

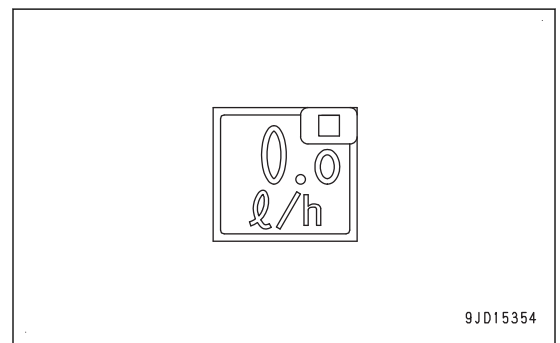

REMARK

Display on the fuel consumption gauge can be switched between the average fuel consumption per day and the average fuel consumption during a selected period (split fuel consumption).

ECO GAUGE

ECO gauge shows the instantaneous fuel consumption.

The instantaneous fuel consumption means the fuel consumption rate at each moment, which varies with the work load and engine speed.

(A) Green range

The instantaneous fuel consumption is at good to medium level.

(B) Yellow range

The instantaneous fuel consumption is at a bad level.

REMARK

Even if the graduation of gauge enters the yellow range, there is no abnormality on the machine. However, for the conservation of global environment, reduce the engine output to a point where there is no adverse effect on the operation, and perform energy saving operations within the green range.

Decrease the frequency of travel. It also helps energy saving operations. Consider the best way of operation for energy saving.

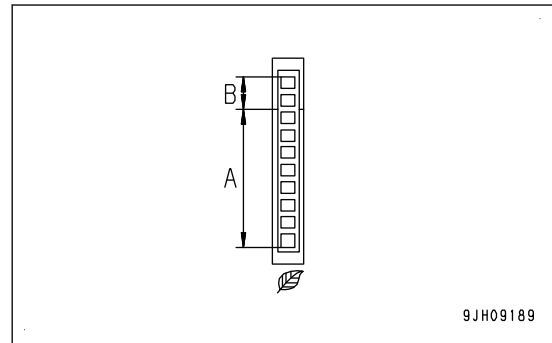

MONITOR SWITCHES

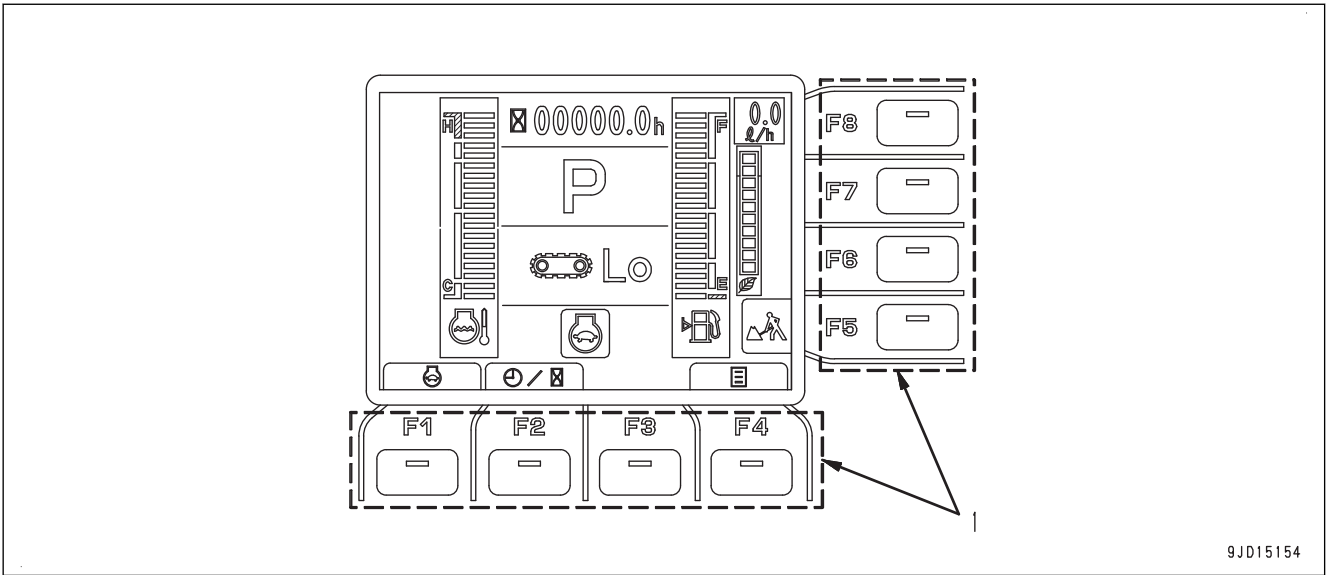

9JD15154

(1) Function switch

FUNCTION SWITCHES AND GUIDANCE ICONS

- There are 8 function switches (1) (“F1” to “F8”) at the bottom and right side of the monitor display. The function of each switch differs in accordance with the content of each screen.
- On each screen, you can confirm the function of function switches (1) by guidance icons (2).
- While guidance icon (2) is not displayed, function switch (1) does not function even if it is pressed.
- Even if guidance icon (2) is pressed, it does not function. Press function switch (1) corresponding to guidance icon (2) to operate the function.

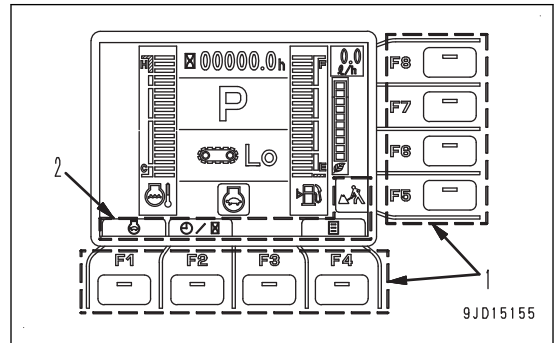

9JD15155

When monitor display is standard screen

The types of guidance icons and functions of function switches are as follows.

For the details of each function, see the detailed explanation of each item.

Function switch “F1”

Display/non-display of auto-deceleration pilot lamp can be switched.

Function switch “F2”

Service meter display and clock display can be switched.

Function switch “F3”

The current abnormality is displayed.

(Only when the caution lamp is lit.)

Function switch “F4”

User menu is displayed.

Function switch “F5”

Working mode setting screen is displayed.

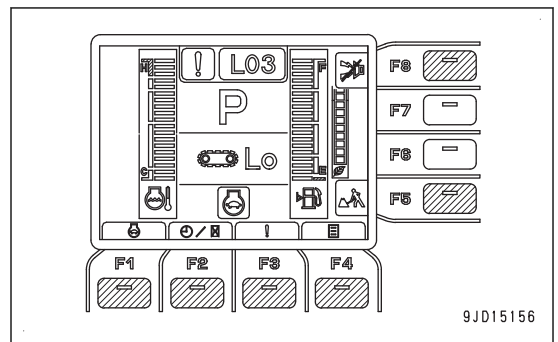

9JD15156

Function switch “F8”

Alarm buzzer stops sounding.

(Only when the alarm buzzer is actuated.)

When monitor display is user menu screen

The types of guidance icons and functions of function switches differ with the contents of the displayed screen, but representative guidance icons frequently used and their functions are as follows:

Function switch “F1”

Moves to the item below (forward).

(When on the last line, it moves to the first line.)

Function switch “F2”

Moves to the item above (backward).

(When on the first line, it moves to the last line.)

Function switch “F3”

Cancels any change and returns the screen to the previous screen.

Function switch “F4”

Enters the selection and contents to change, and advances the screen to the next screen.

Function switch “F6”

Moves to the left item.

(When on the left end, it moves to the right end.)

Function switch “F7”

Moves to the right item.

(When on the right end, it moves to the left end.)

REMARK

- Even if some icons look the same, their display positions and corresponding function switches may differ in accordance with the screens to be displayed.
- For the guidance icons and their functions not explained previously, see the pages where the control methods of respective screens are explained.

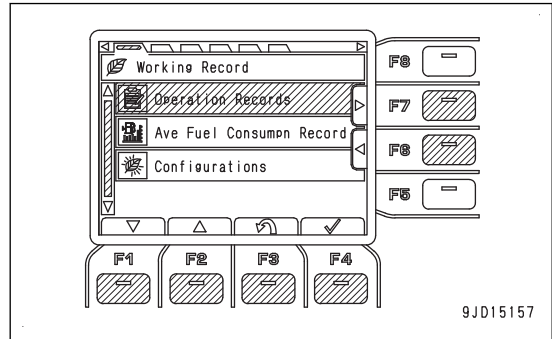

FUNCTION SWITCHES

The operation of the function switches in the standard screen

AUTO-DECELERATION FUNCTION

Perform the setting of auto-deceleration function after starting the engine.

When the auto-deceleration function is ON, if the work equipment control lever and travel lever are returned to NEUTRAL position, the engine speed will drop from the operating speed to idle speed approximately 4 seconds later, and fuel consumption is reduced.

If either of the work equipment control lever or travel lever is operated with the engine at idle speed, engine speed will return to the previous operating speed, and you can perform the operation.

1. When function switch "F1" is pressed, and the auto-deceleration function is turned ON, the auto-deceleration pilot lamp lights up in yellow in the bottom center of machine monitor, and 2 seconds later, it returns to blue.

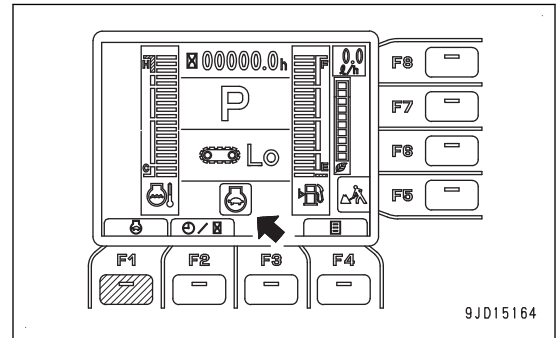

2. When function switch "F1" is pressed again, and the auto-deceleration function is turned off, the auto-deceleration pilot lamp goes out.

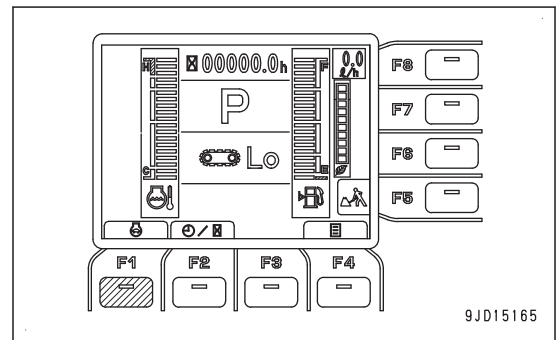

WORKING MODE SELECTION

On “Working Mode” screen, you can set the movement or force of the work equipment in accordance with the content of the operation.

The operation becomes more efficient by selecting the working mode to match the content of the operation.

P mode

For heavy-duty operations

E mode

For operations with emphasis on fuel consumption

B mode

For breaker operations (For machines ready for installation of attachments)

ATT/P mode

For operations of 2-way attachment such as crusher (For machines ready for installation of attachment)

ATT/E mode

For operations with emphasis on fuel consumption out of those of 2-way attachment like crusher (For machines ready for installation of attachment)

- When the machine monitor is turned on, it is automatically set to the mode used when the starting switch was turned to OFF position last.
- Press function switch “F5”, and the working mode selection screen is displayed. For each set mode, “P”, “E”, “B”, “ATT/P”, and “ATT/E” are displayed on working mode display at the top right of the monitor display.
- For machines ready for installation of attachment, the breaker mode and the attachment mode are added to the display.

If you want to have automatic setting of P, E, B, ATT/P or ATT/E mode (optional default setting) when starting engine, ask your Komatsu distributor to change the setting.

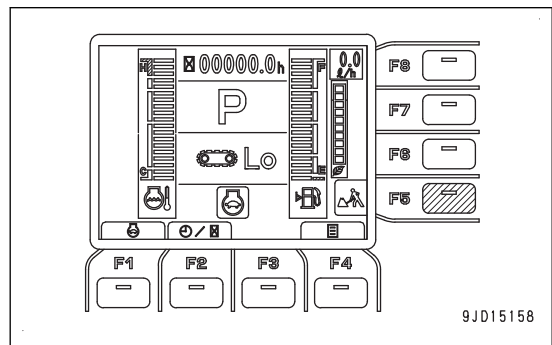
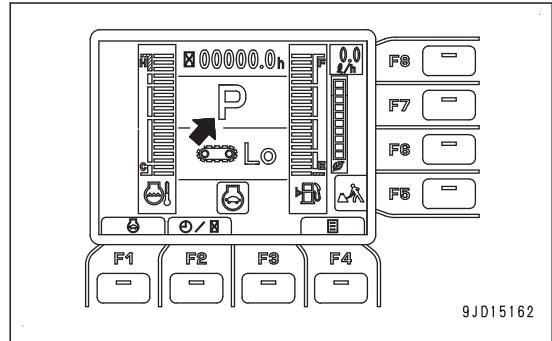

How to use working mode selecting function

Change the setting of auto idle stop function after starting the engine.

1. Press function switch “F5”, and the working mode selection screen is displayed on the machine monitor.
2. Select the working mode with function switches “F1”, “F2”, and “F5”, and enter with function switch “F4”.
To return to the standard screen without changing the working mode, press function switch “F3”.
If a working mode is selected, and nothing is done for 5 seconds, the selected working mode is automatically entered and the screen returns to the standard screen.

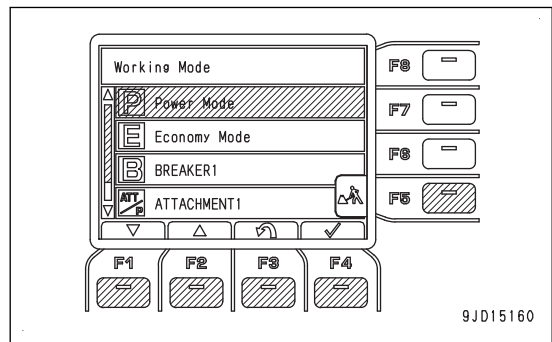

- After the working mode is set, the working mode is displayed in yellow in the center of the monitor display.

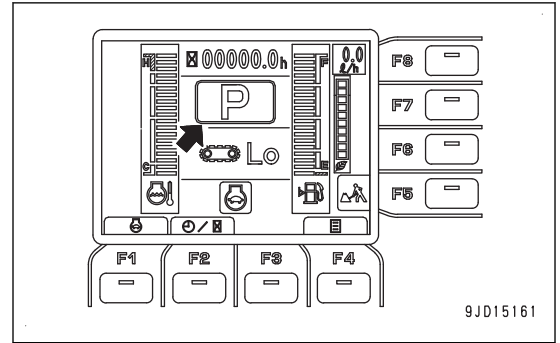

- 2 seconds later, yellow returns to blue.

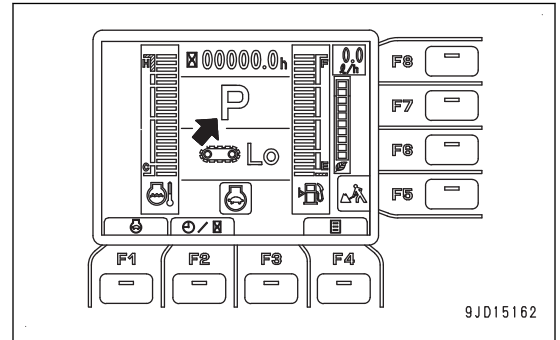

BUZZER CANCEL FUNCTION

Perform the setting of working mode selection after starting the engine.

When buzzer cancel icon is displayed, if you press function switch "F8", alarm buzzer for abnormality of warning items stops sounding.

REMARK

The buzzer cannot be stopped depending on the content of the warning.

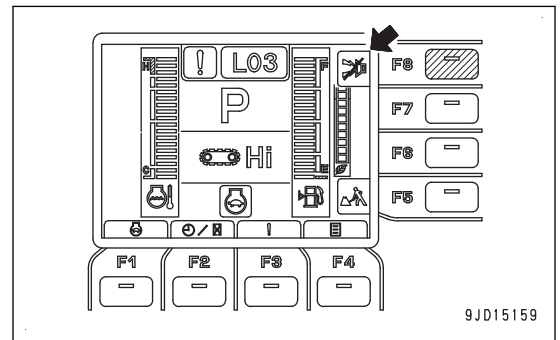

USER MENU

On the standard screen, press switch “F4” to display the user menu screen on the monitor display on which you can make various settings for the machine.

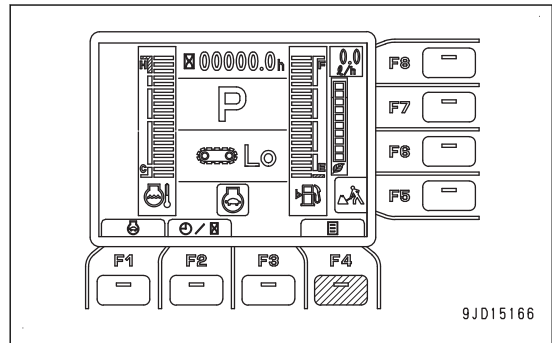

The user menu consists of the following kinds. The right and left menu screens can be changed by pressing the function switches “F6” and “F7”.

- (a): “Working Record”
- (b): “Machine Setting”
- (c): “Aftertreatment Devices Regeneration”
- (d): “Maintenance”
- (e): “Monitor Setting”
- (f): Mail check

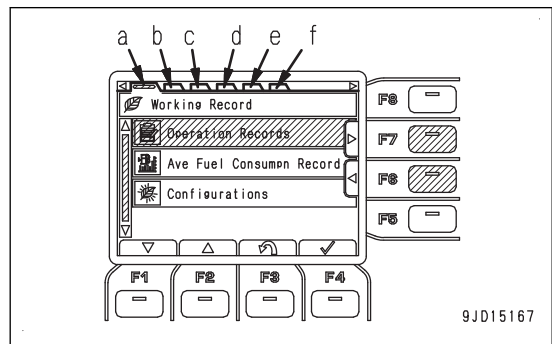

These menus (a) to (f) are for setting and confirming the following items:

For operations in each menu, see the detailed explanation pages of respective items.

(a) “Working Record”

- Check of “Operation Records”
- Check and reset of “Ave Fuel Consumpn Record”
- “Configurations”

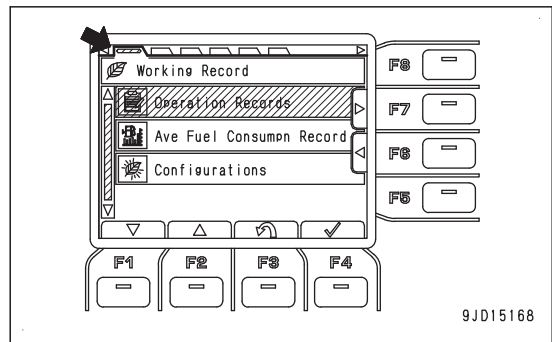

(b) “Machine Setting”

- “Breaker Setting” (if equipped)
- “Attachment Setting” (if equipped)
- “Auto Idle Stop Timer Set”

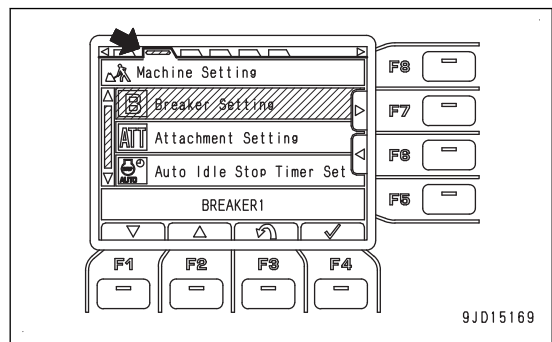

(c) “Aftertreatment Devices Regeneration”

- Setting for “Regeneration Disable”
- Operation of “Manual Stationary Regeneration”

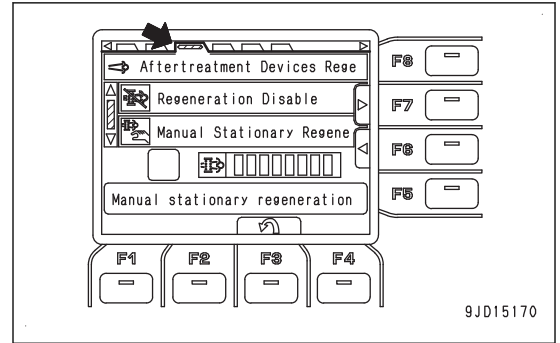

(d) “Maintenance”

- Check and reset of various maintenance times

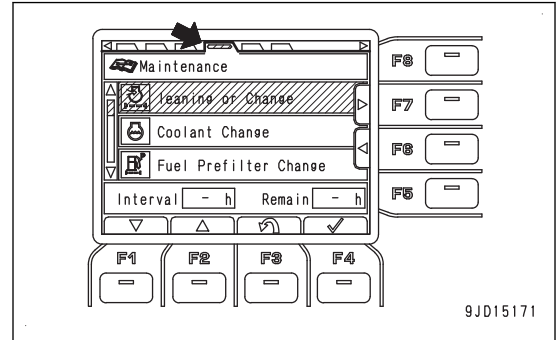

(e) “Monitor Setting”

- “Screen Adjustment”
- “Clock Adjustment”
- “Language”

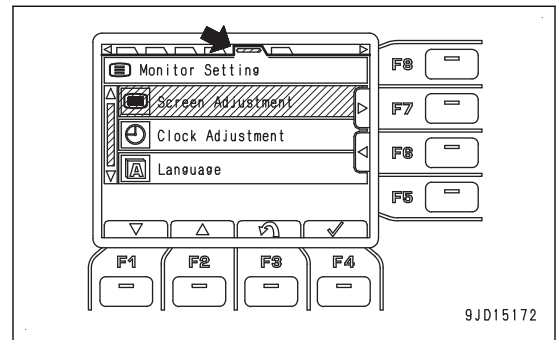

(f) Mail check

- Check of mail contents and reply to mail

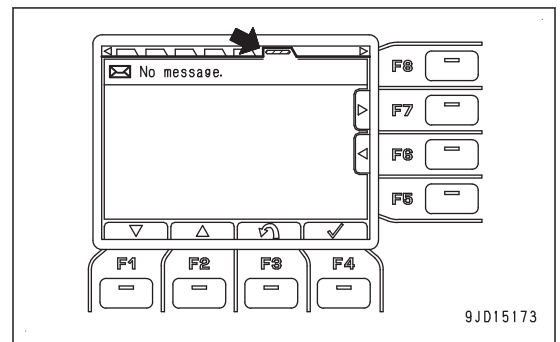

On the user menu screen, you can perform the following operations with function switches “F1” to “F4”, “F6”, and “F7”.

Function switch “F1”

Moves to the next item (1 line below).

When on the last line, it moves to the first line.

Function switch “F2”

Moves to the previous item (1 line above).

When on the first line, it moves to the last line.

Function switch “F3”

Return to the standard screen.

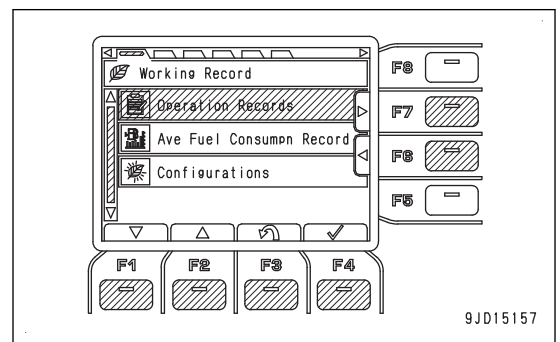

Function switch “F4”

Displays the setting screen for the selected item.

Function switch “F6”

Moves to the left menu.

When on the left end menu, it moves to the right end menu.

Function switch “F7”

Moves to the right menu.

When on the right end menu, it moves to the left end menu.

REMARK

If no switch is operated for 30 seconds on the user menu screen, the screen returns to the standard screen.

WORKING RECORD

On each item of “Working Record” menu screen, you can display and set the notification relevant to operation state of the machine.

- “Operation Records”
- “Ave Fuel Consumpn Record”
- “Configurations”

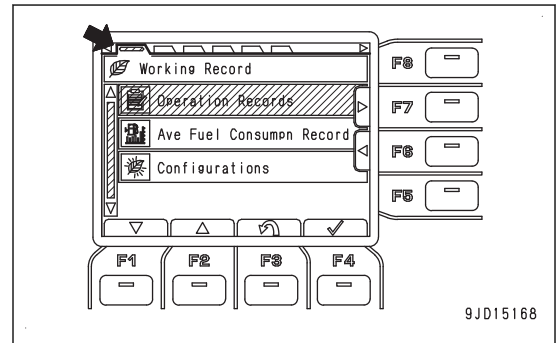

CHECK OPERATING RECORD

Select “Operation Records” on “Working Record” menu screen, and then press function switch “F4”.

If you select each item of “Operation Records” screen, each data on daily basis or on a split measurement period basis are displayed at the bottom.

On “Operation Records” screen, following items are displayed.

- “Working Hours (Engine On)”
- “Average Fuel Consumption”
- “Actual Working Hours”
- “Ave Fuel Consumption (Actual Working)”
- “Fuel Consumption”
- “Idling Hours”
- “Economy Mode Ratio”

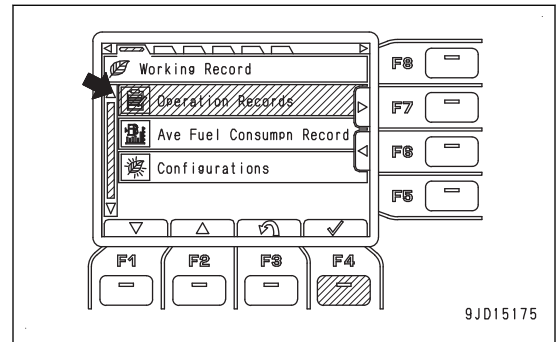

Operation on “Operation Records” screen

On “Operation Records” screen, you can perform the following operations with function switches “F1” to “F3”.

Function switch “F1”

Moves to the next item (1 line below).

When on the last line, it moves to the first line.

Function switch “F2”

Moves to the previous item (1 line above).

When on the first line, it moves to the last line.

Function switch “F3”

Returns the screen to “Working Record” menu screen.

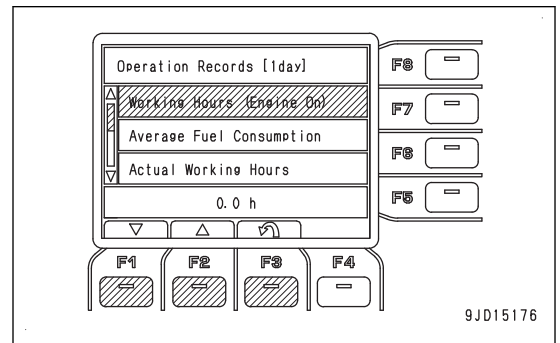

CHECK FUEL CONSUMPTION RECORD

Select "Ave Fuel Consumpn Record" on "Working Record" menu screen, and then press function switch "F4".

On "Ave Fuel Consumpn Record" screen, display the graph of hourly average fuel consumption during the last 12 hours or the graph of daily fuel consumption during the last 1 week.

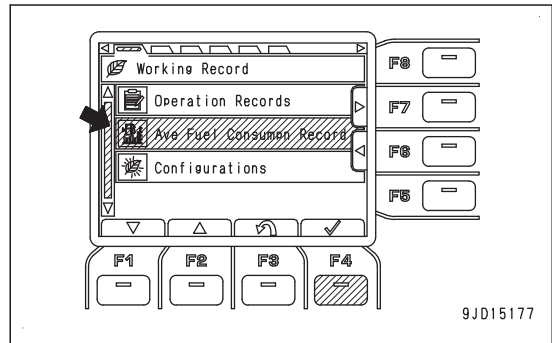

Operation on "Ave Fuel Consumpn Record" screen

On "Ave Fuel Consumpn Record" screen, you can perform the following operations with function switches "F1", "F3", and "F8".

Function switch "F1"

Switches graphical displays of the average fuel consumption.

Function switch "F3"

Returns the screen to "Working Record" menu screen.

Function switch "F8"

Clears the graph data.

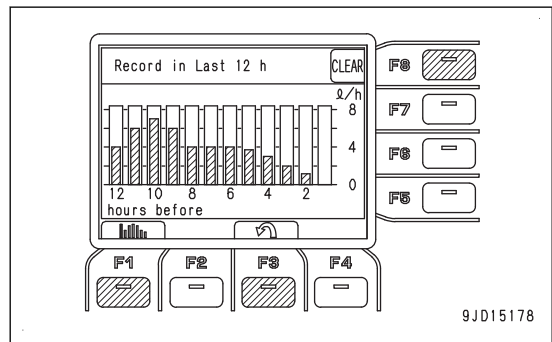

REMARK

The displayed value of fuel consumption and the fuel consumption rate may differ from the actual value due to the operating conditions of the customers (fuel, weather or work contents, etc.).

Switching of displayed graph

On "Ave Fuel Consumpn Record" screen, if you press function switch "F1", graph display changes between hourly average fuel consumption during the last 12 hours and daily fuel consumption during the last 1 week.

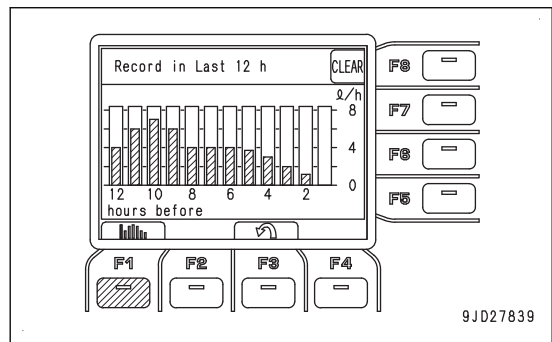

- Last 12 hours display

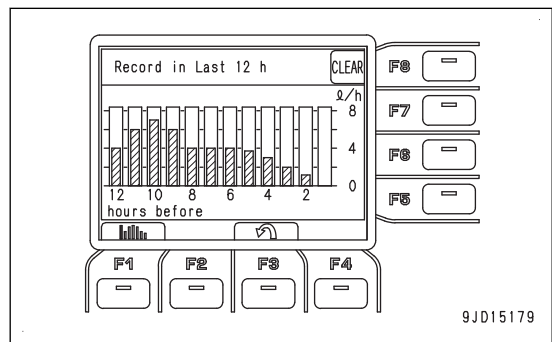

- Last 1 week display

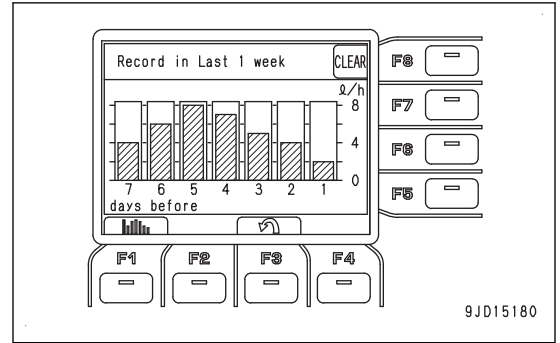

Deleting of record

Perform the resetting of fuel consumption record after starting the engine.

1. When you press switch "F8", the reconfirmation screen is displayed.

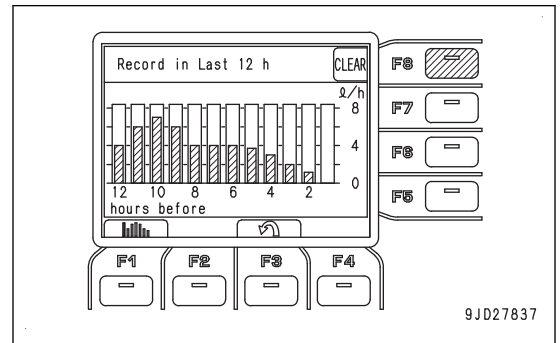

2. If you press function switch "F4", graphs data of the last 12 hours and the last 1 week are both deleted, and the screen returns to "Ave Fuel Consumpn Record" screen.

REMARK

Press function switch "F3" to cancel the data deletion (clear) operation.

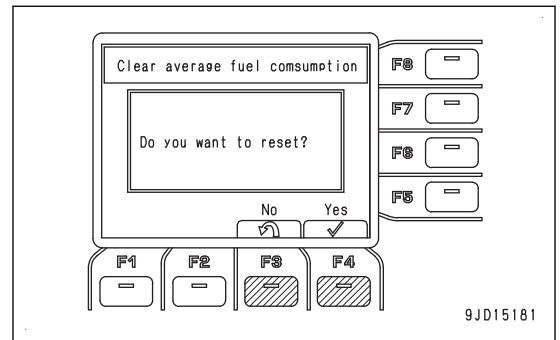

CHANGE DISPLAY SETTING

Select “Configurations” on “Working Record” menu screen, and then press function switch “F4”.

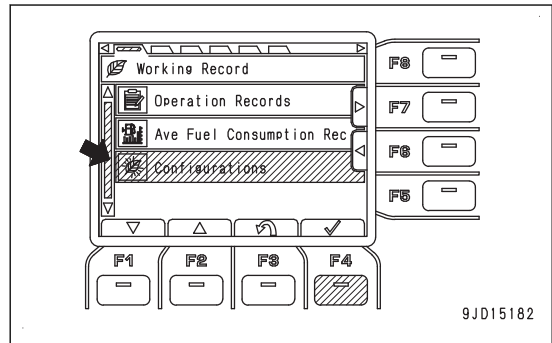

On “Configurations” menu, you can change the following settings.

- Setting of “Ave Fuel Consumption Display”
- Switching Display/Non-display of “ECO Gauge Display”
- Setting of “ECO Gauge Display Fuel Target Value”

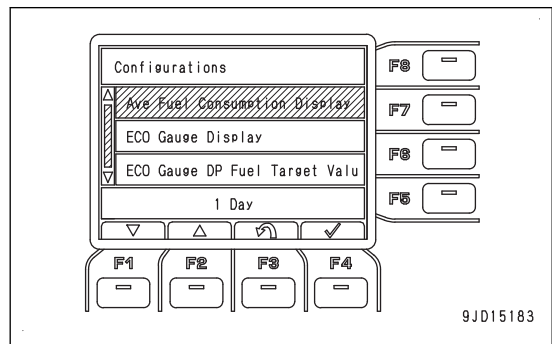

Operations on “Configurations” menu screen

On “Configurations” screen, you can perform the following operations with function switches “F1” to “F4”.

Function switch “F1”

Moves to the next item (1 line below).
When on the last line, it moves to the first line.

Function switch “F2”

Moves to the previous item (1 line above).
When on the first line, it moves to the last line.

Function switch “F3”

Returns the screen to “Working Record” menu screen.

Function switch “F4”

Displays the setting screen for the selected item.

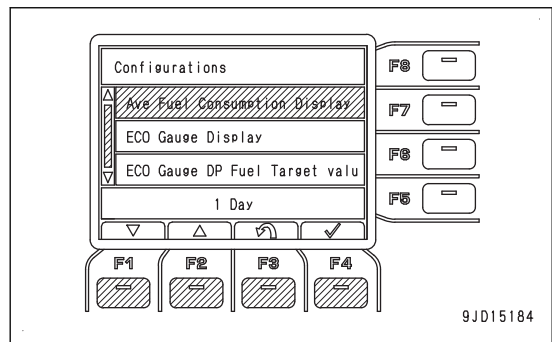

SET DISPLAY OF FUEL CONSUMPTION GAUGE

Perform the setting of fuel consumption display after starting the engine.

On “Ave Fuel Consumption Display” screen, the display of fuel consumption gauge can be set 1 Day display or Split Time display or Non-display.

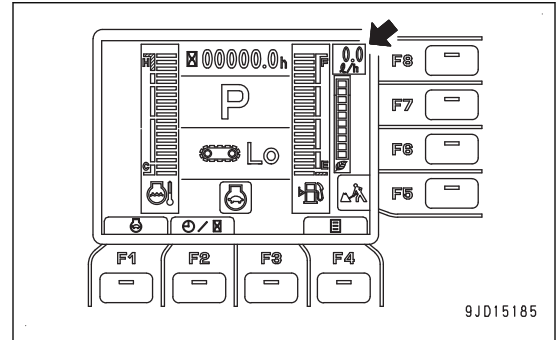

1. Select “Ave Fuel Consumption Display” on “Configurations” menu screen, and then press function switch “F4”.

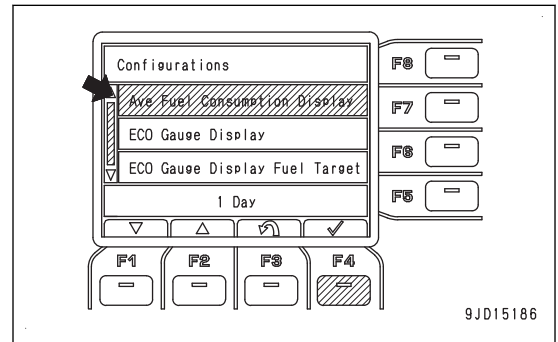

2. “Ave Fuel Consumption Display” screen is displayed. On “Ave Fuel Consumption Display” screen, you can change following settings.

“1 Day”

Displays the average fuel consumption from 0:00 a.m. of the day to 0:00 a.m. of the next day.

“Split Time”

Displays the average fuel consumption during the split measurement period.

Select “Split Time” to start the automatic measurement of fuel consumption.

“OFF”

Does not display the fuel consumption gauge.

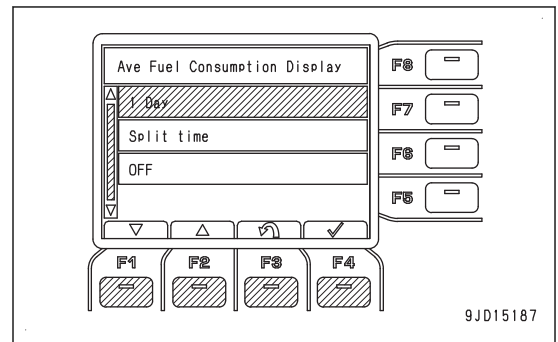

On “Ave Fuel Consumption Display” screen, you can perform the following operations with function switches “F1” to “F4”.

Function switch “F1”

Moves to the next item (1 line below).
When on the last line, it moves to the first line.

Function switch “F2”

Moves to the previous item (1 line above).
When on the first line, it moves to the last line.

Function switch “F3”

Cancels the selected change and returns the screen to “Configurations” menu screen.

Function switch “F4”

Allocates the selected change, and returns the screen to “Configurations” menu screen.

REMARK

If you select Split Time measurement, "SPLIT" is displayed at the top right of "Operation Records" screen.

If you want to stop the measurement, press function switch "F8" on "Operation Records" screen, and move to "Split Time Information" screen, and then press function switch "F1" ("STOP").

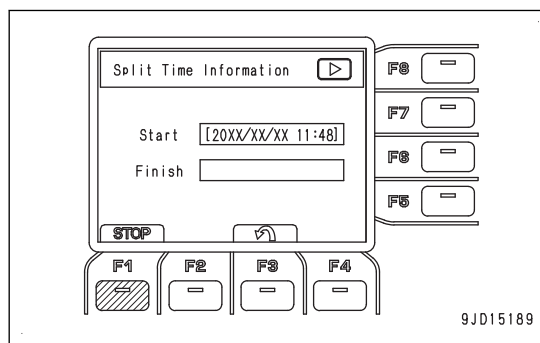
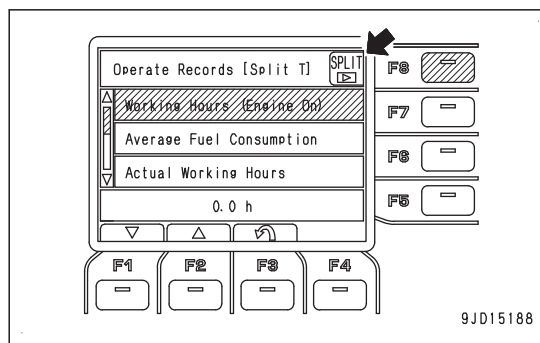

SWITCH DISPLAY/NON-DISPLAY OF ECO GAUGE

Set the ECO gauge to be displayed or not to be displayed after starting the engine.

It is possible to change the setting of Display/Non-display of the ECO gauge.

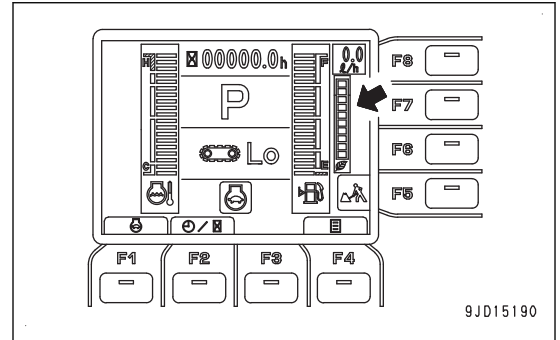

1. Select "ECO Gauge Display" on "Configurations" menu screen, and then press function switch "F4".

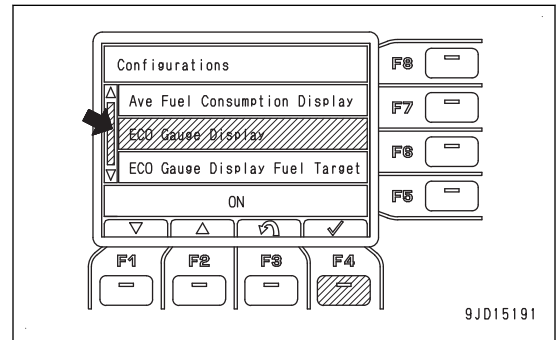

2. The "ECO Gauge Display" screen is displayed.

"ON"

Displays the ECO gauge on the standard screen.

"OFF"

Does not display the ECO gauge on the standard screen.

On "ECO Gauge Display" screen, you can perform the following operations with function switches "F1" to "F4".

Function switch "F1"

Moves to the next item (1 line below).

When on the last line, it moves to the first line.

Function switch "F2"

Moves to the previous item (1 line above).

When on the first line, it moves to the last line.

Function switch "F3"

Cancels the selected change and returns the screen to "Configurations" menu screen.

Function switch "F4"

Allocates the selected change, and returns the screen to "Configurations" menu screen.

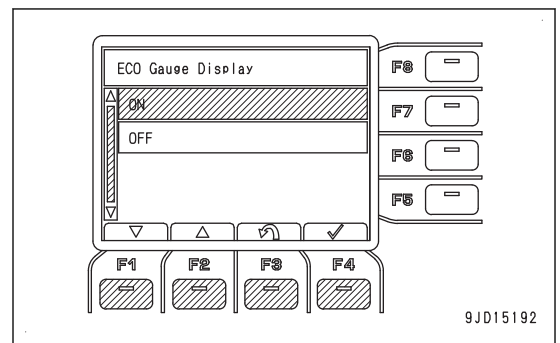

SET TARGET FUEL CONSUMPTION VALUE DISPLAYED IN ECO GAUGE

Perform the setting of fuel target value of ECO gauge display after starting the engine.

It is possible to change the target fuel consumption value (the upper limit value of the green range) of the ECO gauge.

- 1. Select "ECO Gauge Display Fuel Target Value" on "Configurations" menu screen, and then press function switch "F4".

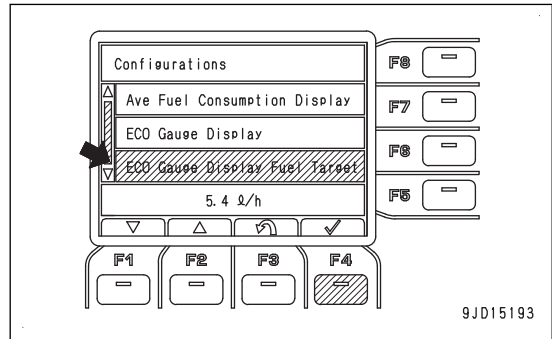

- 2. "ECO Gauge Display Fuel Target Value" screen is displayed.

On "ECO Gauge Display Fuel Target Value" screen, you can perform the following operations with function switches "F1" to "F4", "F6", and "F7".

Function switch "F1"

Decreases the target fuel consumption value by 1.

Function switch "F2"

Increases the target fuel consumption value by 1.

Function switch "F3"

Cancels change of setting, and the screen returns to "Configurations" menu screen.

Function switch "F4"

Allocates change of setting, and returns the screen to "Configurations" menu screen.

Function switch "F6"

Moves to the left one.

When on the first letter, it moves to the last letter.

Function switch "F7"

Moves to the right one.

When on the last letter, it moves to the first letter.

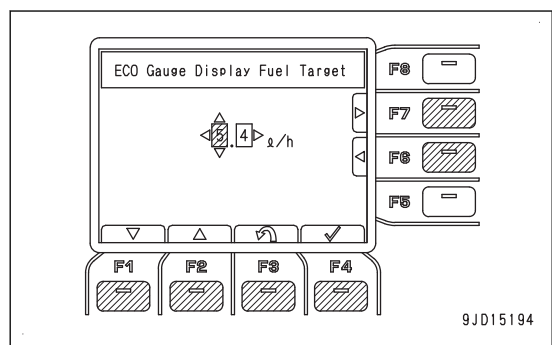

MACHINE SETTINGS

On each item of “Machine Setting” menu screen, setting related to the machine can be performed.

- “Breaker Setting” (if equipped)
- “Attachment Setting” (if equipped)
- “Auto Idle Stop Timer Set”

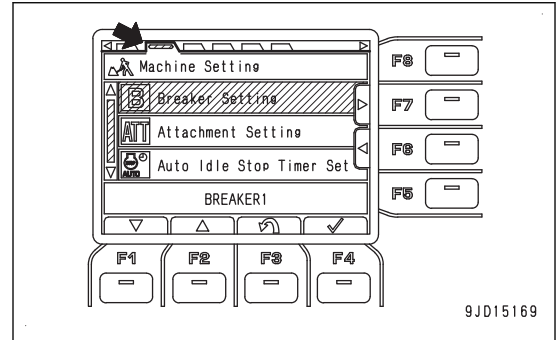

BREAKER SETTING

For the machine(s) ready for installation of breaker, you can select the setting of B mode from 5 patterns on “Breaker Setting” screen.

For each pattern on “Breaker Setting” screen, you can change its name displayed on the machine monitor.

For each pattern on “Breaker Setting” screen in B mode, you can adjust oil flow rate to the breaker corresponding to the operation.

For machines that have no breaker, “Breaker Setting” screen is not displayed.

1. Select “Breaker Setting” on “Machine Setting” menu screen, and then press function switch “F4”.

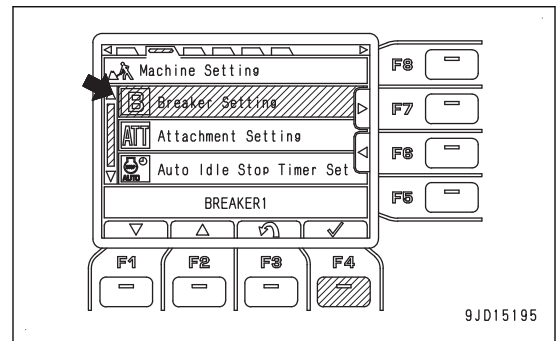

2. “Breaker Setting” screen is displayed.

Select the setting corresponding to the operation on “Breaker Setting” screen, and then press function switch “F4”.

Setting of B mode is changed.

On “Breaker Setting” screen, you can perform the following operations with function switches “F1” to “F4”, “F6”, and “F7”.

Function switch “F1”

Moves to the next item (1 line below).

When on the last line, it moves to the first line.

Function switch “F2”

Moves to the previous item (1 line above).

When on the first line, it moves to the last line.

Function switch “F3”

Cancels the selection and returns the screen to “Machine Setting” menu screen.

Function switch “F4”

Allocates the selected setting to the setting when B mode is selected.

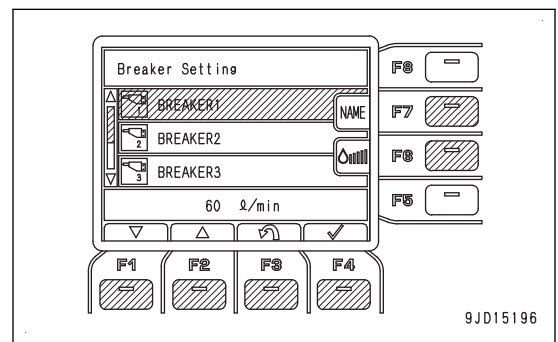

Function switch “F6”

Changes the flow rate of the selected breaker setting.

Function switch “F7”

Changes the name of the selected breaker setting.

Changing the Breaker Setting name

Change the name of breaker setting after starting the engine.

You can change the name of each pattern for the breaker setting as you like.

You can use alphabet letters (A to Z), Arabic numerals (0 to 9), symbols (#, *, +, -, and /), and the blank (space).

- 1. Select the breaker setting to change its name on “Breaker Setting” screen, and then press function switch “F7”.

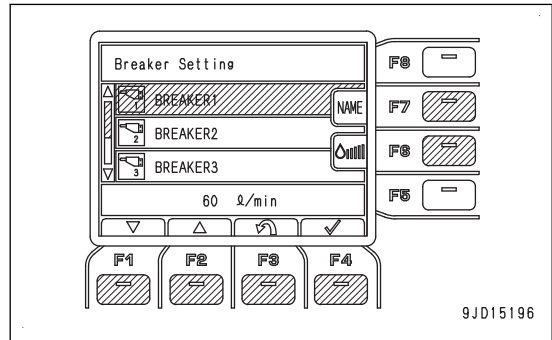

- 2. The “Breaker Name Setting” screen is displayed.

On “Breaker Name Setting” screen, you can perform the following operations with function switches “F1” to “F4”, “F6”, “F7”, and “F8”.

Function switch “F1”

Moves to the previous alphabet, numeral, or symbol.

Function switch “F2”

Moves to the next alphabet, numeral, or symbol.

Function switch “F3”

Returns the screen to “Breaker Setting” screen without changing the name.

Function switch “F4”

Enters the change and returns the screen to “Breaker Setting” screen.

Function switch “F6”

Moves to the left letter.

When on the first letter, it moves to the last letter.

Function switch “F7”

Moves to the right letter.

When on the last letter, it moves to the first letter.

Function switch “F8”

If some input letter is left, “CLEAR” is displayed.

Clears all the letters.

If all the letters are cleared, “DEFAULT” is displayed.

Displays the initial name.

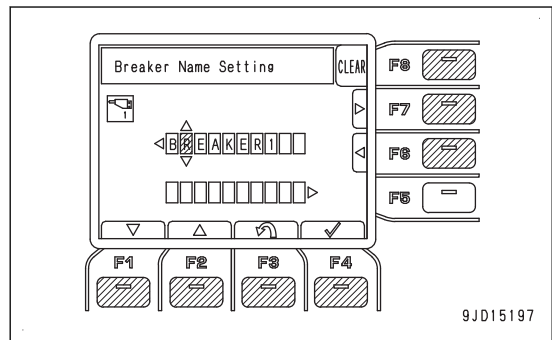

Changing “Breaker Oil Flow Rate Setting”

You can change the flow rate of each breaker setting to the arbitrary value.

1. Select the breaker setting to change its flow rate on "Breaker Setting" screen, and then press function switch "F6".

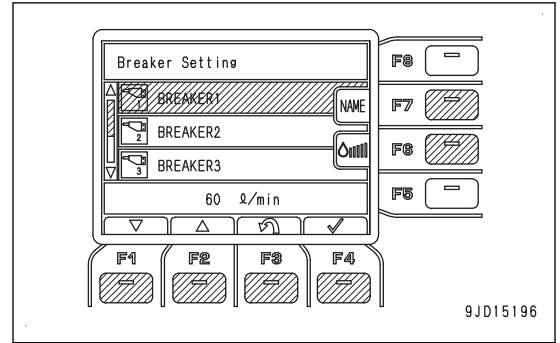

2. The "Breaker Oil Flow Rate Setting" screen is displayed.

On "Breaker Oil Flow Rate Setting" screen, you can perform the following operations with function switches "F3", "F4", "F6", and "F7".

Function switch "F3"

Returns the screen to "Breaker Setting" screen without changing the flow rate.

Function switch "F4"

Enters the flow rate setting and returns the screen to "Breaker Setting" screen.

Function switch "F6"

Decreases the flow rate by 1 level.

Function switch "F7"

Increases the flow rate by 1 level.

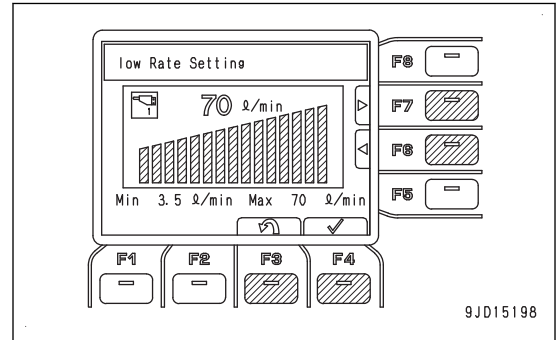

ATTACHMENT SETTING

For the machine(s) ready for installation of attachment, you can select the setting of ATT/P and ATT/E modes from 5 patterns on “Attachment Setting” screen, or you can set it to “No Attachment”.

For each pattern on “Attachment Setting” screen, you can change its name displayed on the machine monitor.

For each pattern on “Attachment Setting” screen, you can adjust oil flow rate to the attachment corresponding to the installed attachment.

For machines that have no attachment, “Attachment Setting” screen is not displayed.

1. Select “Attachment Setting” on “Machine Setting” menu screen, and then press function switch “F4”.

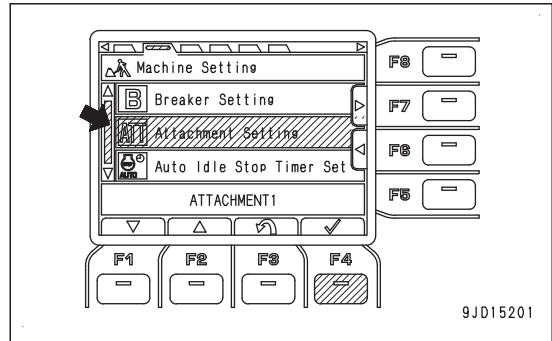

2. “Attachment Setting” screen is displayed.

Select proper setting matching to the installed attachment on “Attachment Setting” screen, and then press function switch “F4”.

Setting of ATT/P and ATT/E mode is changed.

On “Attachment Setting” screen, you can perform the following operations with function switches “F1” to “F4”, “F6”, and “F7”.

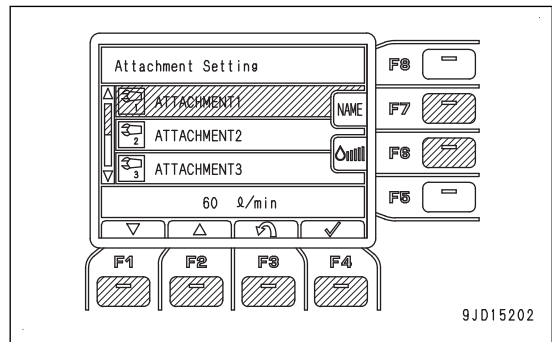

Function switch “F1”

Moves to the next item (1 line below).

When on the last line, it moves to the first line.

Function switch “F2”

Moves to the previous item (1 line above).

When on the first line, it moves to the last line.

Function switch “F3”

Cancels the selection and returns the screen to “Machine Setting” screen.

Function switch “F4”

Allocates the selected setting to that of ATT/P and ATT/E mode, or set it to the No Attachment.

Function switch “F6”

Changes the flow rate of the selected attachment setting.

Function switch “F7”

Changes the name of the selected attachment setting.

REMARK

When “No Attachment” is selected, ATT/P and ATT/E mode is cleared from “Working Mode” screen, and you cannot select the mode.

Changing attachment setting name

Change the name of attachment setting after starting the engine.

You can change the name of each pattern for the attachment setting as you like.

You can use alphabet letters (A to Z), Arabic numerals (0 to 9), symbols (#, *, +, -, and /), and the blank (space).

1. Select an attachment setting to change its name on "Attachment Setting" screen, and then press function switch "F7".

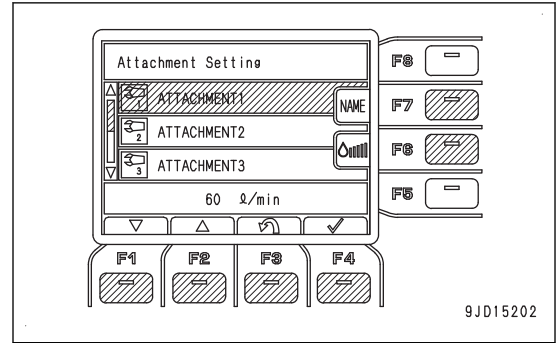

2. "Attachment Name Setting" screen is displayed. On "Attachment Name Setting" screen, you can perform the following operations with function switches "F1" to "F4", "F6", "F7", and "F8".

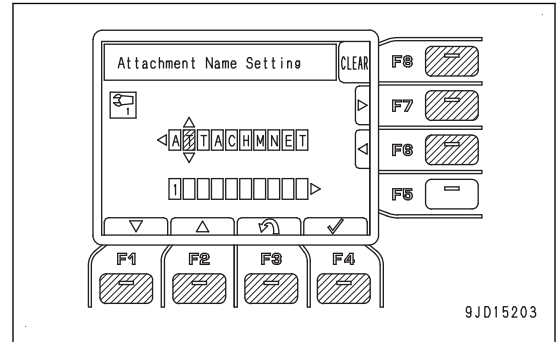

Function switch "F1"

Moves to the previous alphabet, numeral, or symbol.

Function switch "F2"

Moves to the next alphabet, numeral, or symbol.

Function switch "F3"

Returns the screen to "Attachment Setting" screen without changing the name.

Function switch "F4"

Enters the change and returns the screen to "Attachment Setting" screen.

Function switch "F6"

Moves to the left letter.

When on the first letter, it moves to the last letter.

Function switch "F7"

Moves to the right letter.

When on the last letter, it moves to the first letter.

Function switch "F8"

If some input letter is left, "CLEAR" is displayed.

Clears all the letters.

If all the letters are cleared, "DEFAULT" is displayed.

Displays the initial name.

It is not possible to change the name for "No Attachment" setting.

Changing "2-Way Attachment Oil Flow Rate Setting"

You can change the flow rate of each attachment setting to the arbitrary value.

1. Select an attachment setting to change its flow rate on "Attachment Setting" screen, and then press function switch "F6".

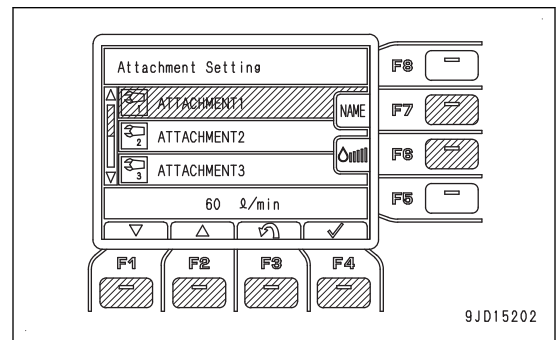

2. The “2-Way Attachment Oil Flow Rate Setting” screen is displayed.

On “2-Way Attachment Oil Flow Rate Setting” screen, you can perform the following operations with function switches “F3”, “F4”, “F6”, and “F7”.

Function switch “F3”

Returns to “Attachment Setting” screen without changing the flow rate.

Function switch “F4”

Enters the flow rate setting and returns the screen to “Attachment Setting” screen.

Function switch “F6”

Decreases the flow rate by 1 level.

Function switch “F7”

Increases the flow rate by 1 level.

It is not possible to change the flow rate for “No Attachment” setting.

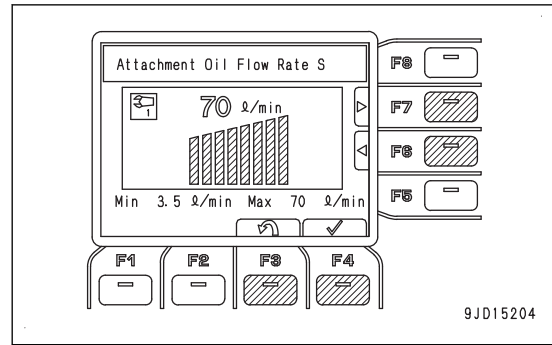

AUTO IDLE STOP TIMER SETTING

NOTICE

Battery runs out faster because the only engine stops when auto idle stop function is actuated.

Actuate the auto idle stop function after a lapse of 15 minutes of running the engine at high idle and in P mode.

The auto idle stop function stops the engine automatically when the elapsed time of idling exceeds the preset time with the lock lever in LOCK position.

The auto idle stop function operates when the following conditions are all satisfied.

- The engine is running normally.
- The lock lever is in LOCK position.
- The engine coolant is not overheated.
- The engine is not in warm-up operation.

On “Auto Idle Stop Timer Set” screen, you can select the time to operate the auto idle stop function, or “OFF”.

Change of auto idle stop timer setting

Change the auto idle stop timer setting after starting the engine.

1. Select “Auto Idle Stop Timer Set” on “Machine Setting” menu screen, and then press function switch “F4”.

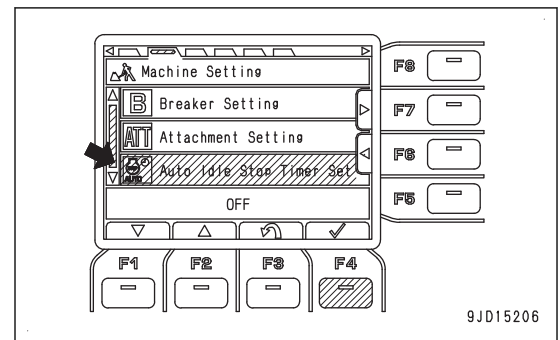

2. Select the setting time on “Auto Idle Stop Timer Set” selection screen, and then press function switch “F4”.

On “Auto Idle Stop Timer Set” selection screen, it is possible to perform the following operations with function switches “F1” to “F4”.

Function switch “F1”

Moves to the next item (1 line below).

When on the last line, it moves to the first line.

Function switch “F2”

Moves to the previous item (1 line above).

When on the first line, it moves to the last line.

Function switch “F3”

Cancels the selection and returns the screen to “Machine Setting” menu screen.

Function switch “F4”

The screen changes to “Auto Idle Stop Timer Set” confirmation screen.

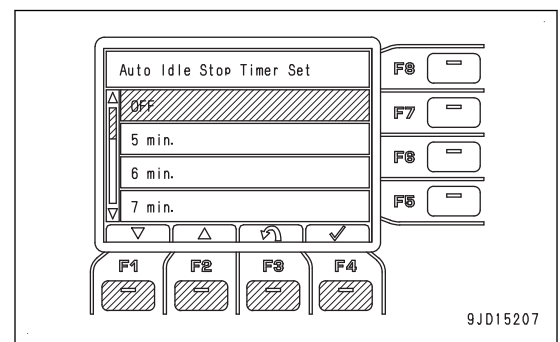

REMARK

- If you select “OFF”, auto idle stop function does not operate.
- You cannot select a time longer than that specified in the service menu.

3. "Auto Idle Stop Timer Set" confirmation screen is displayed.

Press function switch "F4" on "Auto Idle Stop Timer Set" confirmation screen.
 If you press function switch "F3", the screen returns to "Auto Idle Stop Timer Set" selection screen.

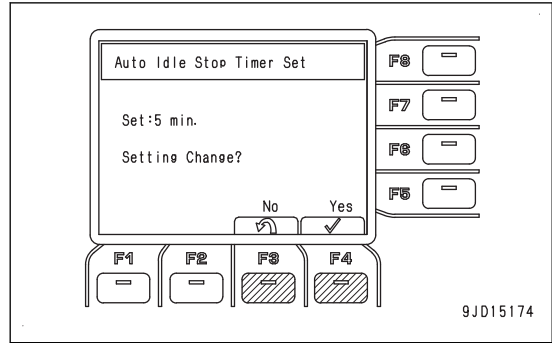

4. "Auto Idle Stop Timer Set" completion screen is displayed.

If you press function switch "F4" on "Auto Idle Stop Timer Set" completion screen, the screen returns to "Machine Setting" menu screen.

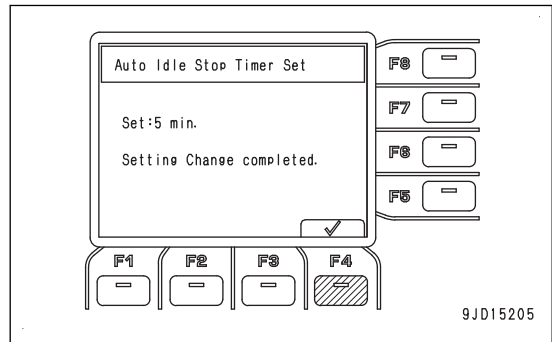

When the elapsed time of idling reaches 30 seconds before the preset time, the machine monitor returns to the standard screen, and changes to the countdown screen, and the guidance icon on the bottom right lights up in yellow.

If you press function switch "F4", the screen changes to "Auto Idle Stop" screen and you can check the state.

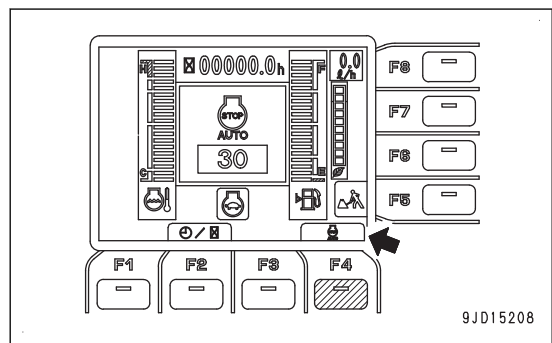

When the lock lever is set to FREE position according to the screen instructions, the countdown stops and the screen returns to the standard screen.

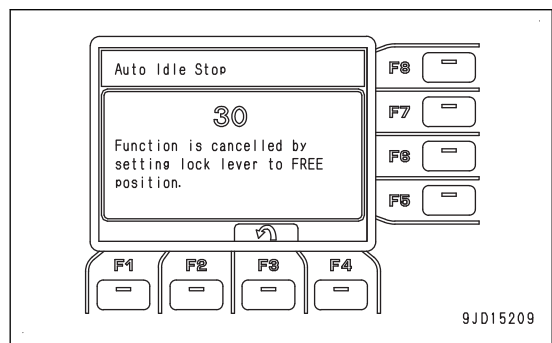

5. When countdown reaches 0, the engine stops and the guidance icon on the bottom right lights up in red.

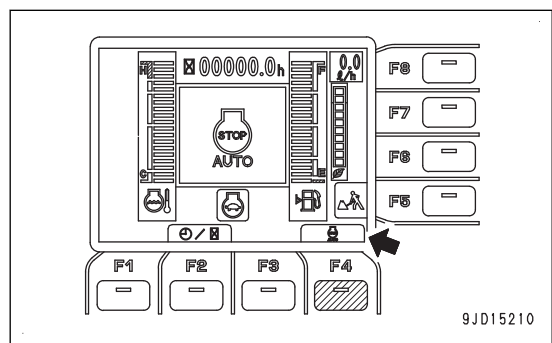

If you press function switch "F4", the screen changes to "Auto Idle Stop in Operation" screen.

6. Turn off unnecessary switches according to the screen instructions.

REMARK

With the auto idle stop function, only the engine is stopped.

The machine monitor, inverter, etc., as well as the electrical components including the lamps, wipers, and radio, keep their states before the engine is stopped.

7. Turn the starting switch to OFF position.
This prevents battery discharging.
8. When restarting the engine, turn the starting switch as usual.

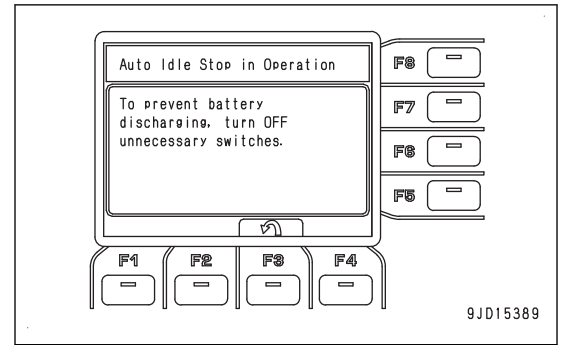

AFTERTREATMENT DEVICES REGENERATION

Each item of “Aftertreatment Devices Regeneration” menu screen is for settings and operations of the aftertreatment devices regeneration.

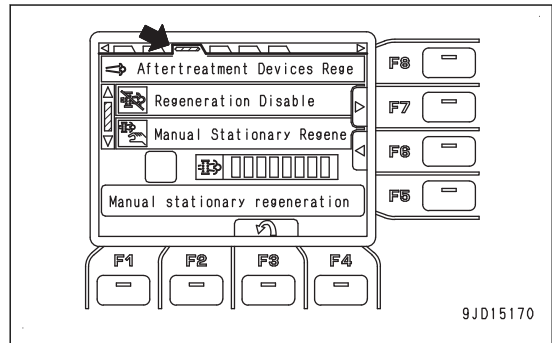

MAINTENANCE SCREEN SETTING

On each item of "Maintenance" menu screen, the notification related to maintenance can be displayed and set.

The items on maintenance display are as follows.

a	b
Air Cleaner Cleaning or Change	-
Coolant Change	-
Fuel Prefilter Change	500
Engine Oil Change	500
Engine Oil Filter Change	500
Hyd Oil Tank Breather Change	500
Fuel Main Filter Change	500
Hydraulic Oil Filter Change	1000
Final Drive Case Oil Change	1000
Hydraulic Oil Change	2000
KDPF Filter Cleaning	6000

- a: Maintenance items
- b: Default maintenance interval settings (h)
- c: Time remaining to maintenance (h)

REMARK

When resetting the time remaining to the maintenance, keep function switch "F4" pressed for at least 1.5 seconds. If time of pressing function switch "F4" is short, the function switch operating sound can be heard, but the screen does not switch to "Maintenance Due Time Reset" screen.

- If no switch is operated for 30 seconds on "Maintenance" menu screen, the screen automatically returns to the standard screen.
- When the maintenance time caution lamp is lit on the standard screen, press function switch "F4" on the standard screen and "Maintenance" menu screen is displayed.
- On "Maintenance" menu screen, if the time remaining to the maintenance for any item is less than 30 hours (initial setting value), the remaining time display (c) lights up in yellow. If the time remaining to the maintenance becomes 0 hours or less, the remaining time display (c) lights up in red.
- If you want to change the setting for the maintenance time or maintenance notice time (initial setting: 30 hours), consult your Komatsu distributor.

Operations on Maintenance Due Time Reset screen

Perform the resetting of maintenance due time after starting the engine.

1. Select the item to reset on "Maintenance" menu screen.
2. Keep pressing function switch "F4" for 1.5 seconds or more.

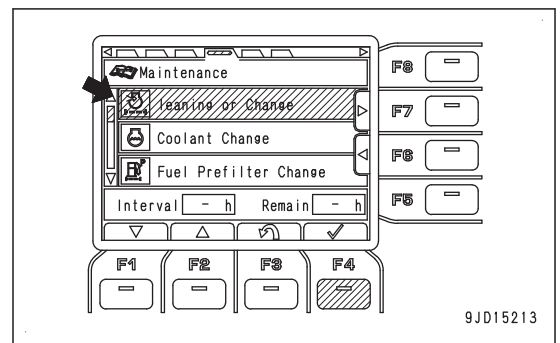
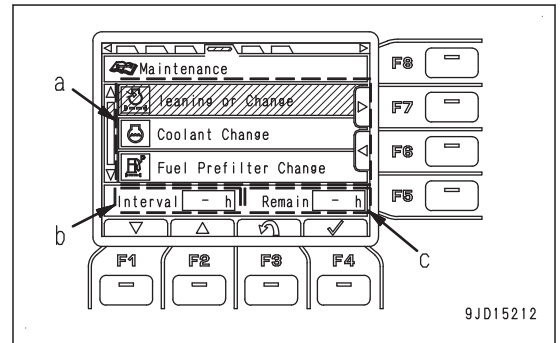

3. "Maintenance Due Time Reset" screen is displayed.

Press function switch "F4" on "Maintenance Due Time Reset" screen.

The screen switches to the reconfirmation screen.

REMARK

- When canceling the reset, press function switch "F3". The screen returns to "Maintenance" screen.
- On "Maintenance Due Time Reset" screen, if no switch is operated for more than 30 seconds, the screen automatically changes to "Maintenance" screen.

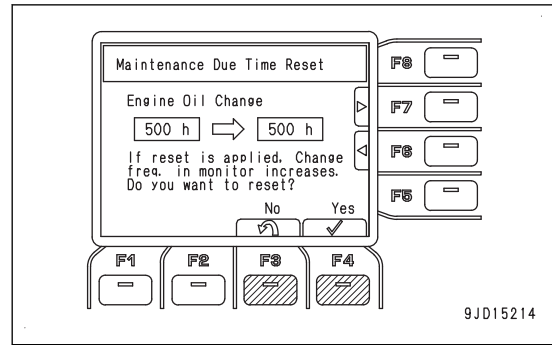

4. Press function switch "F4" on the reconfirmation screen.

The remaining time is reset and the screen returns to "Maintenance" screen.

REMARK

- When canceling the reset, press function switch "F3". The screen returns to "Maintenance" screen.
- On "Maintenance Due Time Reset" screen, if no switch is operated for more than 30 seconds, the screen automatically changes to "Maintenance" screen.

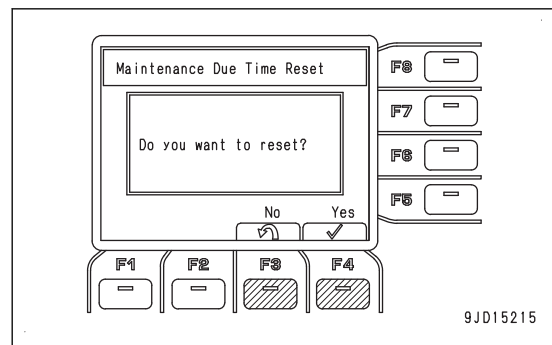

MONITOR SETTINGS

On each item of “Monitor Setting” menu screen, you can perform the setting related to the monitor.

- “Screen Adjustment”
- “Clock Adjustment”
- “Language”

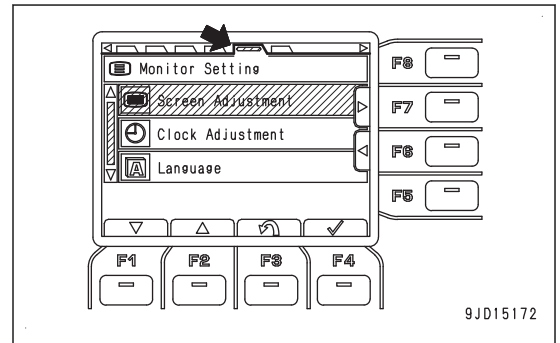

SCREEN ADJUSTMENT

Adjust the screen after starting the engine.

Use “Screen Adjustment” screen to adjust the brightness of the monitor screen.

1. Select “Screen Adjustment” on “Monitor Setting” menu screen, and then press the function switch “F4”.

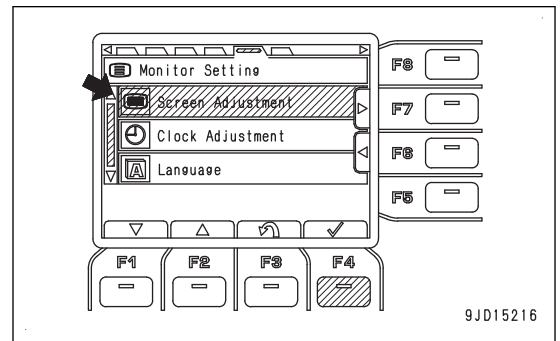

2. Operate the function switches “F3”, “F4”, “F6”, “F7”, and “F8” to adjust the brightness of the screen.

Function switch “F3”

Cancels the change of brightness of the screen and the screen returns to “Monitor Setting” menu screen.

Function switch “F4”

Allocates the change of brightness of the screen and the screen returns to “Monitor Setting” menu screen.

Function switch “F6”

Moves the graduation to the left by one level.

Function switch “F7”

Moves the graduation to the right by one level.

Function switch “F8”

Resets an adjusted value to the default value.

REMARK

- If the lamp switch is at NIGHT position, and the screen is adjusted, it is possible to adjust the brightness of the monitor screen (night mode).
- If the lamp switch is at DAY position, and the screen is adjusted, it is possible to adjust the brightness of the monitor screen (day mode).

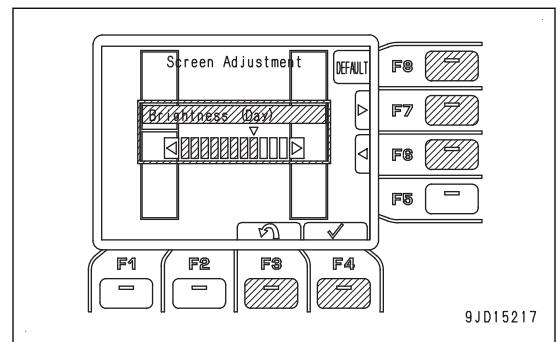

CLOCK ADJUSTMENT

“Clock Adjustment” menu screen is used to change the setting of the clock displayed on the standard screen.

1. Select “Clock Adjustment” on “Monitor Setting” menu screen, and then press function switch “F4”.

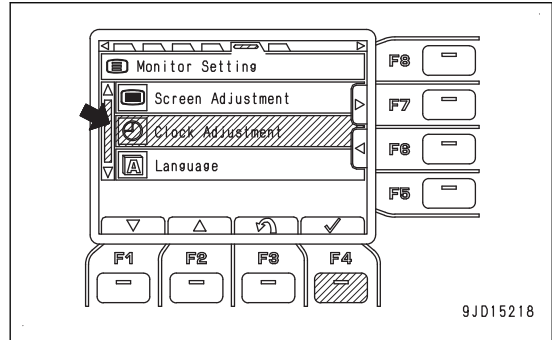

2. “Clock Adjustment” screen is displayed.
The items related to “Clock Adjustment” are following 5 items.

- “GPS Synchronization”
- “Calendar”
- “Time”
- “12h/24h Mode”
- “Daylight Saving Time”

On “Clock Adjustment” menu screen, you can perform the following operations with function switches “F1” to “F4”.

Function switch “F1”

Moves to the next item (1 line below).
When on the last line, it moves to the first line.

Function switch “F2”

Moves to the previous item (1 line above).
When on the first line, it moves to the last line.

Function switch “F3”

Returns the screen to “Monitor Setting” menu screen.

Function switch “F4”

Displays the setting screen for the selected item.

REMARK

- “Calendar” and “Time” need to be readjusted since they are reset after a long-term storage.
- When “GPS Synchronization” is set to “ON”, 2 items of “Calendar” and “Time” are automatically readjusted.

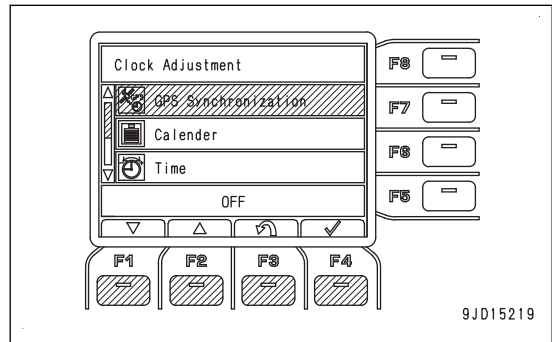

GPS SYNCHRONIZATION SETTING

Perform the setting of GPS synchronization after starting the engine.

For the machines equipped with KOMTRAX, you can configure automatic adjustment of the date and time of machine monitor in accordance with the clock of GPS on “GPS Synchronization” screen.

1. Select “GPS Synchronization” on “Clock Adjustment” menu screen, and then press function switch “F4”.

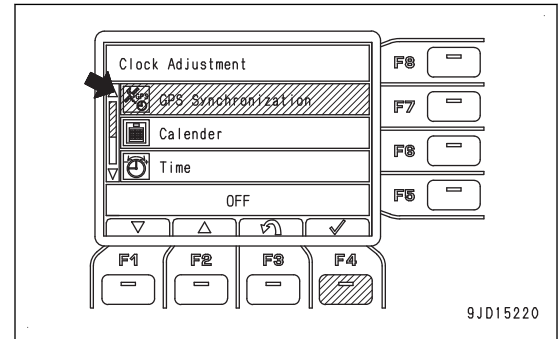

2. “GPS Synchronization” screen is displayed.

“ON”

Date and time on the machine monitor are automatically adjusted in accordance with the clock of GPS.

“OFF”

Date and time on the machine monitor are not synchronized with the clock of GPS.

Manual adjustment is necessary.

On “GPS Synchronization” screen, you can perform the following operations with function switches “F1” to “F4”.

Function switch “F1”

Moves to the next item (1 line below).

When on the last line, it moves to the first line.

Function switch “F2”

Moves to the previous item (1 line above).

When on the first line, it moves to the last line.

Function switch “F3”

Cancels the selected setting, and returns the screen to “Clock Adjustment” menu screen.

Function switch “F4”

Allocates the selected setting, and returns the screen to “Clock Adjustment” menu screen.

REMARK

- When the machine is in the environment where the radio waves from GPS cannot be received, such as inside of a building, the automatic adjustment may not function.
- While “GPS Synchronization” is turned “ON”, the item of “Calender” and “Time” cannot be selected.

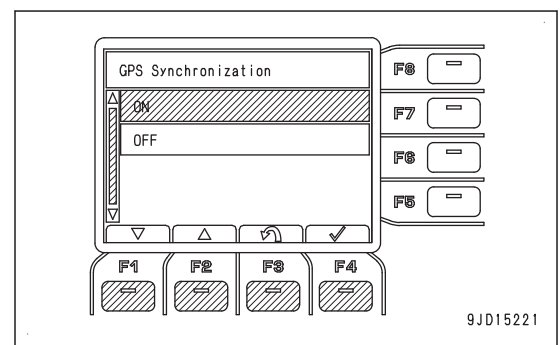

CALENDAR SETTING

Perform the setting of calendar after starting the engine.

The date of the machine monitor can be adjusted on “Calendar” screen.

REMARK

As long as “GPS Synchronization” is turned “ON”, item in “Calendar” is not selectable.

1. Select “Calendar” on “Clock Adjustment” menu screen, and then press function switch “F4”.

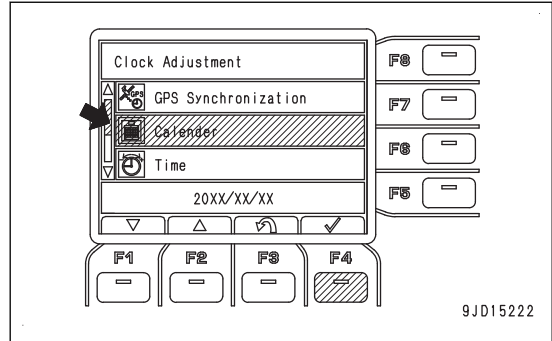

2. “Calendar” screen is displayed.

Change the date of calendar according to the following operation.

You can change the numeral displayed in yellow.

Function switch “F1”

Puts back the numeral by 1.

Function switch “F2”

Advances the numeral by 1.

Function switch “F3”

Cancels the date change and returns the screen to “Clock Adjustment” screen.

Function switch “F4”

Allocates the date change and returns the screen to “Clock Adjustment” screen.

Function switch “F6”

Moves to left display.

When on the year display, it moves to the date display.

Function switch “F7”

Moves to the right display.

When on the date display, it moves to the year display.

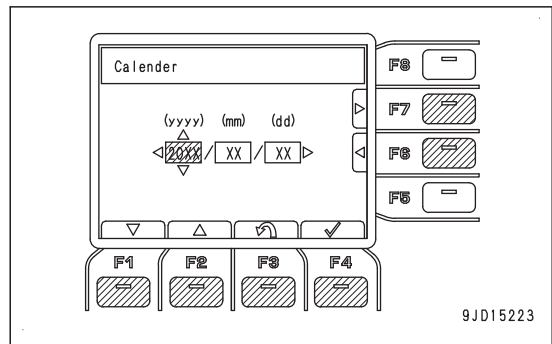

TIME SETTING

Perform the setting of the time after starting the engine.

The time of the machine monitor can be adjusted on "Time" screen.

REMARK

As long as "GPS Synchronization" is turned "ON", you cannot select the item of "Time".

1. Select "Time" on "Clock Adjustment" menu screen, and then press function switch "F4".

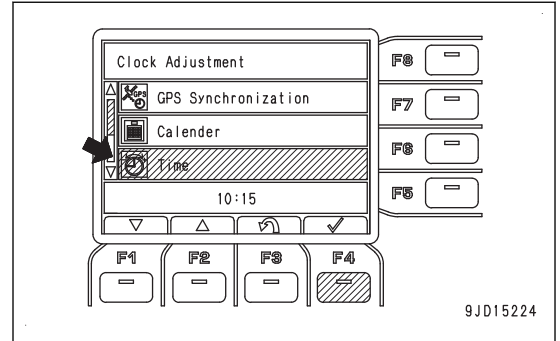

2. "Time" screen is displayed.

Change the time according to the following operation.
You can change the numeral displayed in yellow.

Function switch "F1"

Puts back the numeral by 1.

Function switch "F2"

Advances the numeral by 1.

Function switch "F3"

Cancels the date change and returns the screen to "Clock Adjustment" menu screen.

Function switch "F4"

Allocates the date change and returns the screen to "Clock Adjustment" menu screen.

Function switch "F6"

Moves to the blue display.

Function switch "F7"

Moves to the blue display.

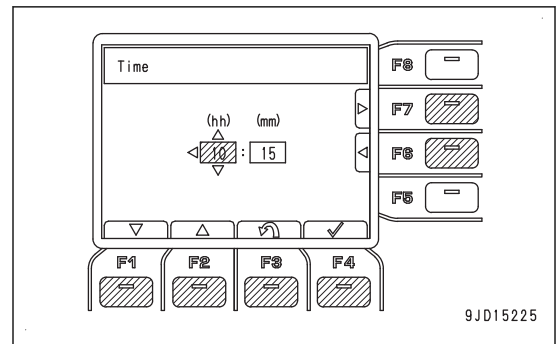

SWITCH 12H/24H DISPLAY MODE

Perform the setting of 12h/24h mode after starting the engine.

On “12h/24h Mode” screen, you can set the display mode of clock.

1. Select “12h/24h Mode” on “Clock Adjustment” menu screen, and then press function switch “F4”.

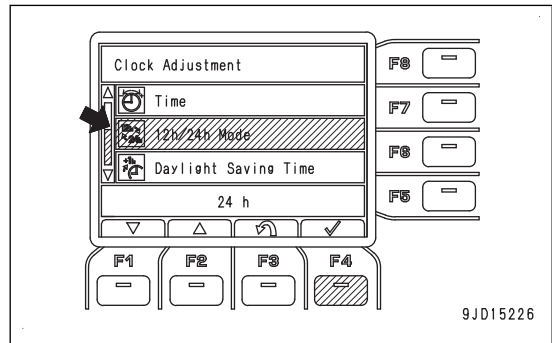

2. “12h/24h Mode” screen is displayed.

“24h”

The clock is displayed in 24-hour mode.

“12h”

The clock is displayed in 12-hour mode with am or pm.

Change the display mode of clock with the following operation.

Function switch “F1”

Moves to the next item (1 line below).

When on the last line, it moves to the first line.

Function switch “F2”

Moves to the previous item (1 line above).

When on the first line, it moves to the last line.

Function switch “F3”

Cancels the selected setting, and returns the screen to “Clock Adjustment” menu screen.

Function switch “F4”

Allocates the selected setting, and returns the screen to “Clock Adjustment” menu screen.

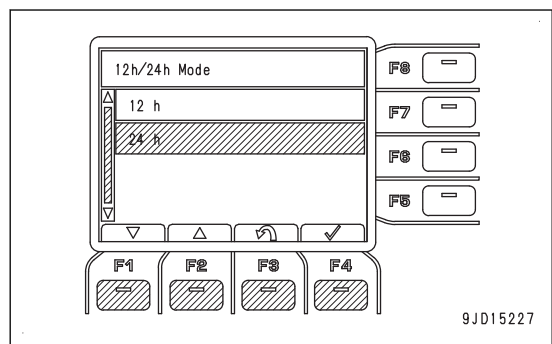

DAYLIGHT SAVING TIME (SUMMER TIME) SETTING

Perform the setting of daylight saving time after starting the engine.

On "Daylight Saving Time" screen, you can set the clock display forward 1 hour.

1. Select "Daylight Saving Time" on "Clock Adjustment" menu screen, and then press function switch "F4".

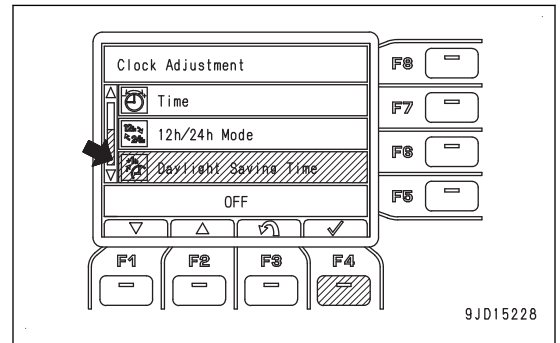

2. The "Daylight Saving Time" screen is displayed.

"ON"

The clock is displayed in daylight saving time (summer time).

The clock display becomes 1 hour forward.

"OFF"

The clock is displayed in normal time.

Change the display mode of clock with the following operation.

Function switch "F1"

Moves to the next item (1 line below).

When on the last line, it moves to the first line.

Function switch "F2"

Moves to the previous item (1 line above).

When on the first line, it moves to the last line.

Function switch "F3"

Cancels the selected setting, and returns the screen to "Clock Adjustment" menu screen.

Function switch "F4"

Allocates the selected setting, and returns the screen to "Clock Adjustment" menu screen.

REMARK

Daylight saving time or summer time means moving the clock forward an hour to take advantage of the fact that the sun rises early in summer in our daily life.

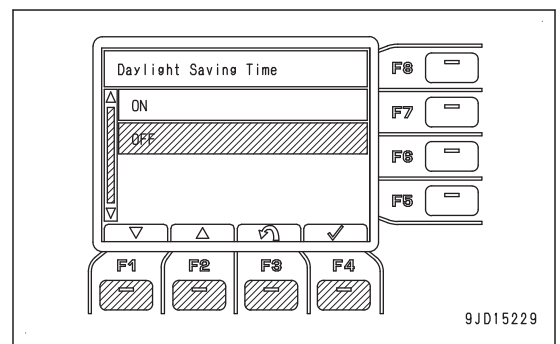

LANGUAGE SETTINGS

Perform the setting of language after starting the engine.

On "Language" screen, you can select the language displayed on the machine monitor.

The languages that can be selected are as follows.

Japanese, English, German, French, Spanish, Portuguese, Italian, Swedish, Dutch, Danish, Norwegian, Finnish, Icelandic, Czech, Hungarian, Polish, Slovak, Slovene, Estonian, Latvian, Lithuanian, Bulgarian, Greek, Romanian, Croatian and Serbian

1. Select "Language" on "Monitor Setting" menu screen, and then press function switch "F4".

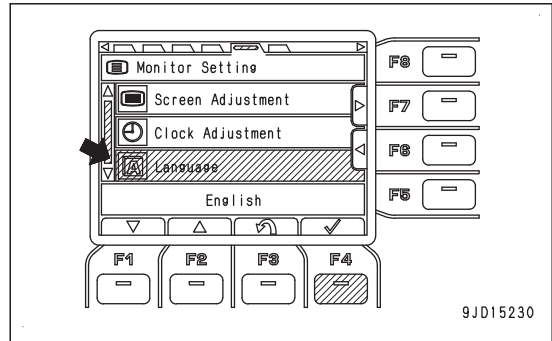

2. "Language" screen is displayed.

Select the language to be displayed, and then press function switch "F4".

The language to be displayed on the machine monitor is changed.

On "Language" screen, you can perform the following operations with function switches "F1" to "F4".

Function switch "F1"

Moves to the next item (1 line below).

When on the last line, it moves to the first line.

Function switch "F2"

Moves to the previous item (1 line above).

When on the first line, it moves to the last line.

Function switch "F3"

Cancels the selected setting, and returns the screen to "Monitor Setting" menu screen.

Function switch "F4"

Allocates the selected setting, and returns the screen to "Monitor Setting" menu screen.

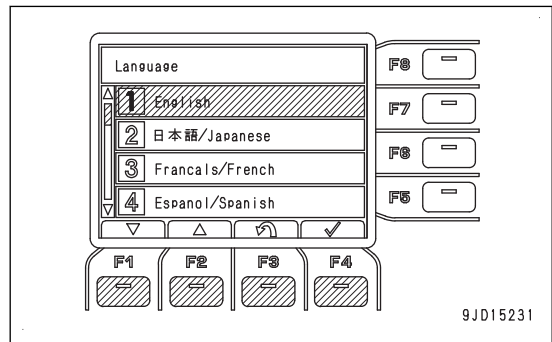

MESSAGE DISPLAY

On machines equipped with KOMTRAX, when message pilot lamp is lit on the standard screen, you can see the messages from your Komatsu distributor on the mail check menu screen by pressing function switch "F4".

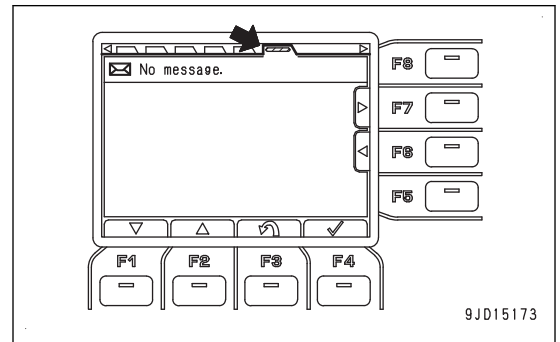
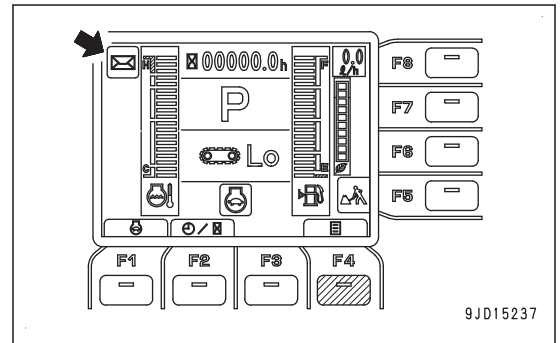

Message is distinguished as follows according to the lighting states of the message display.

Lights up in green

There is unread message.

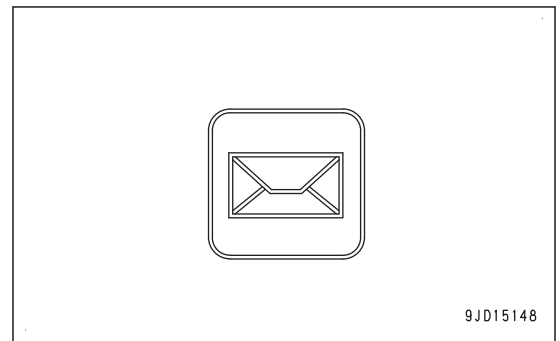

Lights up in blue

There is any read message to which no reply is made.

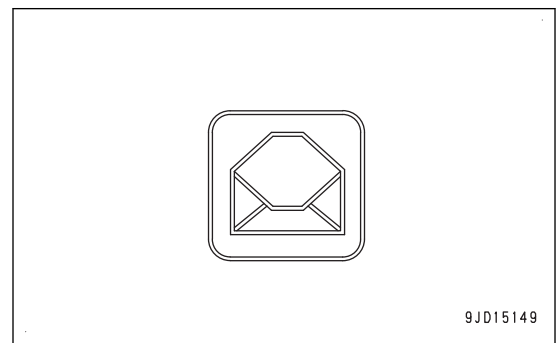

OFF

There is no message.

REMARK

- When the message display lights up in blue, it means that no reply has been made yet to any read message to your Komatsu distributor. Reply to the message according to the replying method mentioned as follows:
- If the starting switch is turned to OFF position when there is any unread message, the message will be displayed on the end screen, and when the monitor is started next time, the message will change to a read message (the message display: lights up in blue).
- The message will be deleted when it becomes out of date or when a new message arrives.

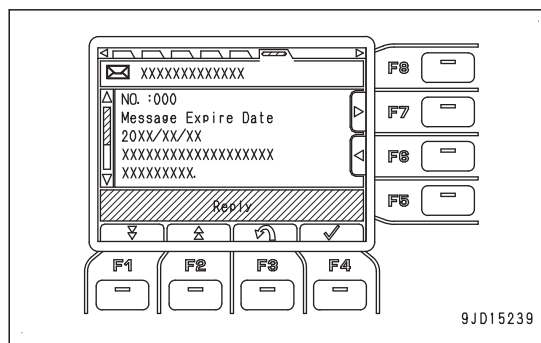

CHECK MESSAGE

1. When the message pilot lamp lights up on the standard screen, press function switch "F4".
The screen changes to the mail confirmation menu screen.

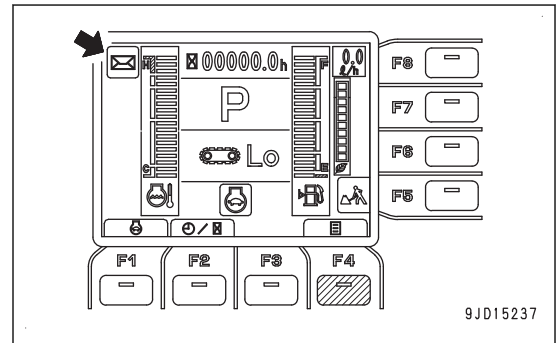

2. On the mail confirmation screen, you can read the arrived message.
If a message requests reply, make a reply to the message.

Function switch "F1"

The message scrolls down.

Function switch "F2"

The message scrolls up.

Function switch "F3"

Return to the standard screen.

Function switch "F4"

If a message requests reply, moves to the screen for replying to the message.

Function switch "F6"

Moves to the left menu.

Function switch "F7"

Moves to the left end menu.

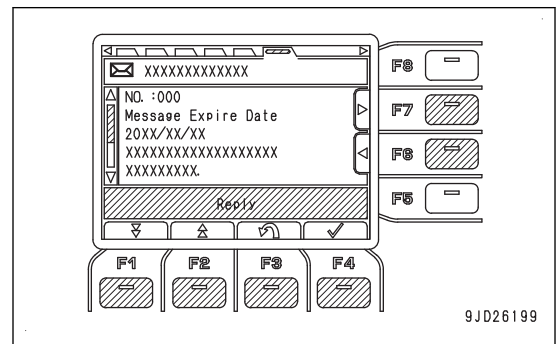

REPLY TO MESSAGE

1. If a message requests reply, press the function switch “F4”, and the screen moves to the message reply screen.
2. On the message reply screen, input the number of selected item as an input value.
The number of selected item is written in the place (1) of the message text on mail confirmation menu screen.

Function switch “F1”

Puts back the input value by 1.

Function switch “F2”

Advances the input value by 1.

Function switch “F3”

Cancels the input value and returns the screen to the mail confirmation menu screen.

Function switch “F4”

Validates the input value, and the screen changes to the mail sending confirmation screen.

3. On the message reply screen, if “Do you send Num Input?” is displayed, press the function switch “F4” again, and input value will be sent.

When “Do you send Num Input?” is displayed, if you press the function switch “F3”, input number of selected item is cleared and the screen returns to the input screen of message reply screen.

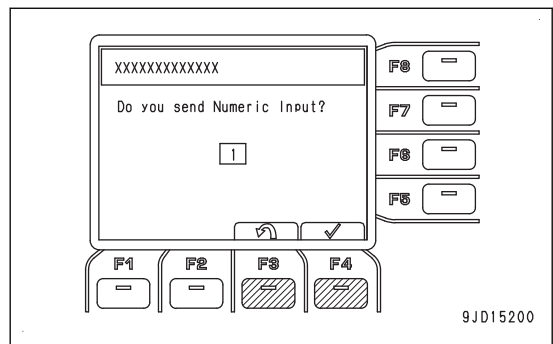
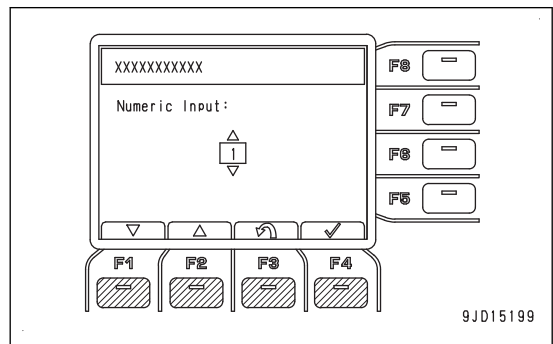
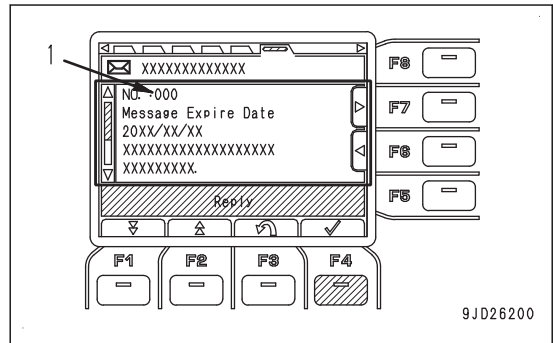

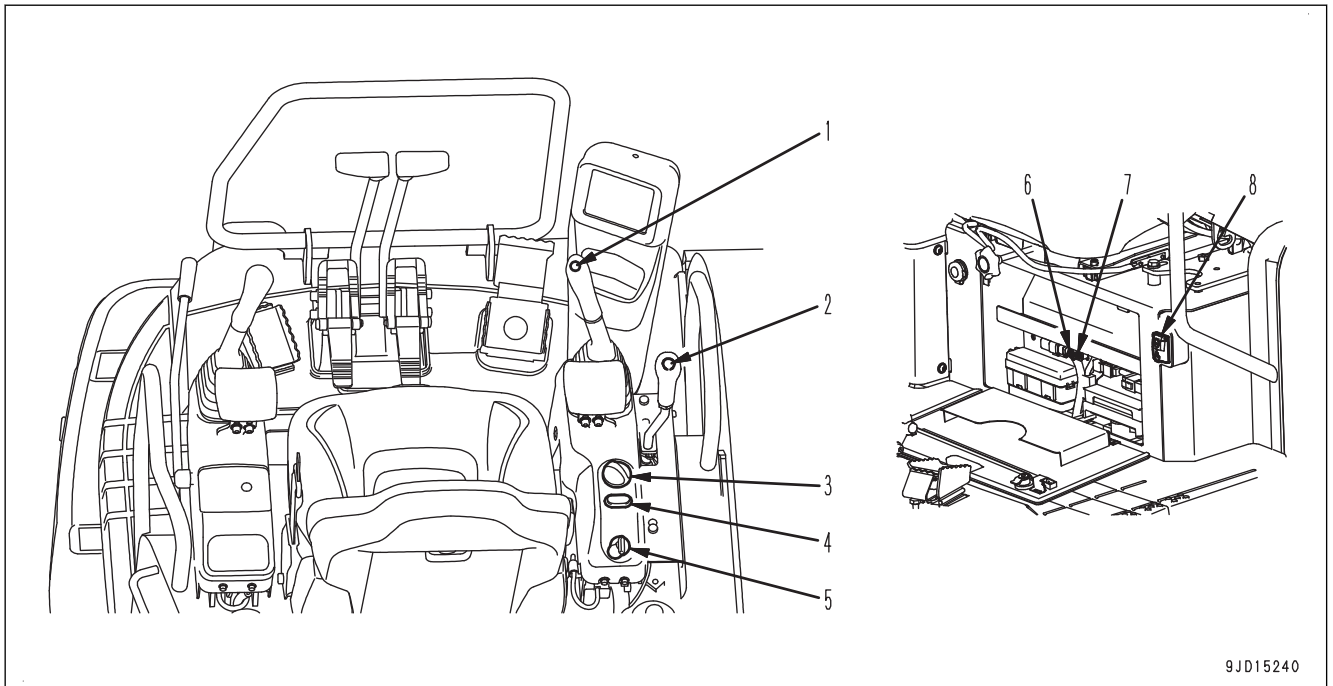
SWITCHES**SWITCHES: CANOPY SPEC**

(1) Horn switch

(2) Travel speed selector switch

(3) Fuel control dial

(4) Lamp switch

(5) Starting switch

(6) Pump secondary drive switch

(7) Lock lever automatic lock cancel switch

(8) Engine shutdown secondary switch

SWITCHES: CAB SPEC

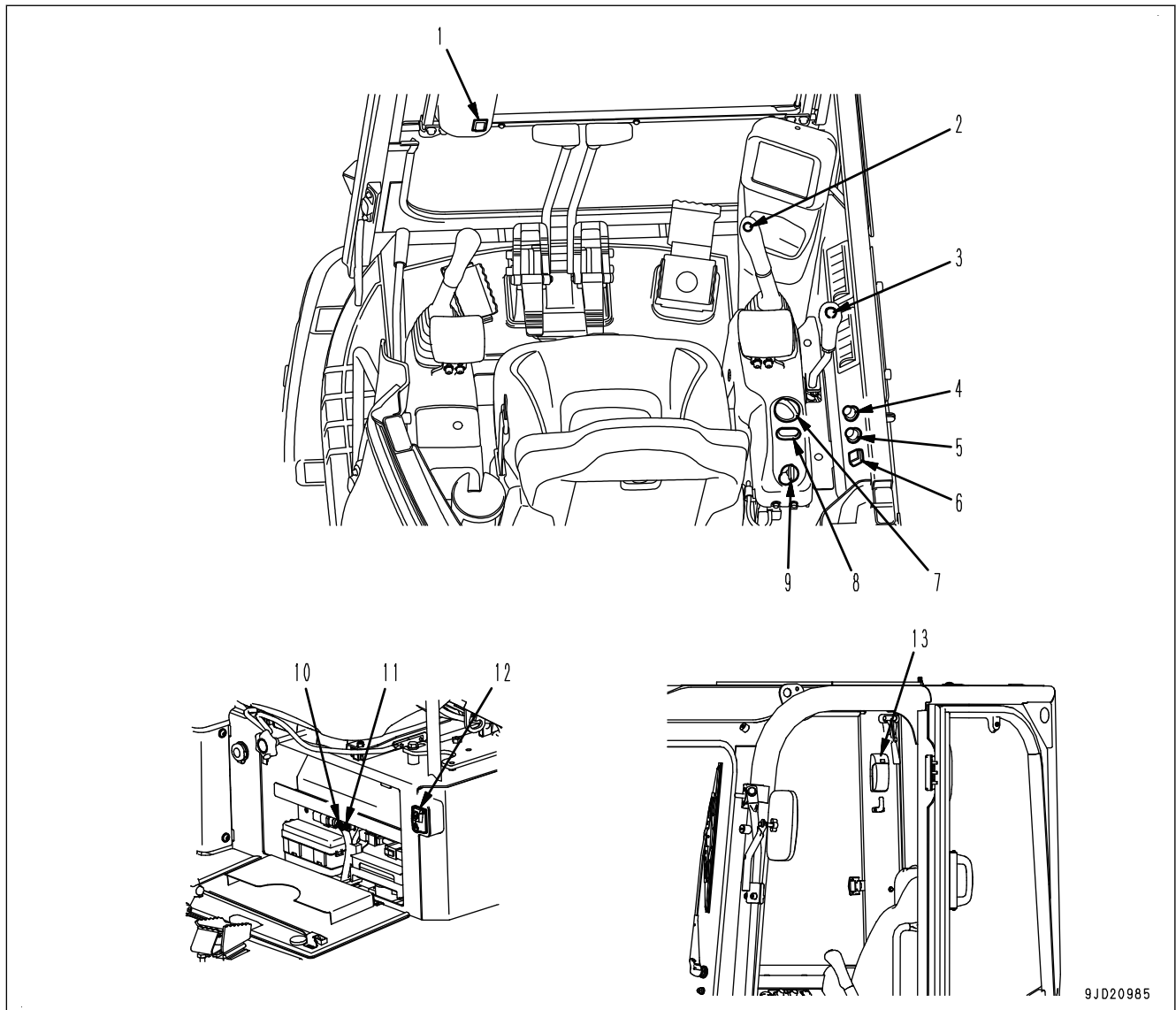

- (1) Wiper switch
- (2) Horn switch
- (3) Travel speed selector switch
- (4) Temperature control switch
- (5) Air flow selector switch
- (6) Air conditioner switch
- (7) Fuel control dial
- (8) Lamp switch
- (9) Starting switch
- (10) Pump secondary drive switch
- (11) Lock lever automatic lock cancel switch
- (12) Engine shutdown secondary switch
- (13) Room lamp switch

STARTING SWITCH

Starting switch is used to start or stop the engine.

(A) OFF position

The electrical current to the electrical system is cut, and the engine stops.

The key can be inserted into or removed from the starting switch.

(B) ON position

Electric current flows through the charging circuit and lamp circuit.

Keep the starting switch key at ON position (B) while the engine is running.

This machine is equipped with an engine automatic preheating device that functions to start the engine preheating automatically.

When the key in starting switch is turned to ON position (B) at low ambient temperature, the automatic preheating starts and the preheating pilot lamp lights up.

(C) START position

This is the position to start the engine.

Keep the key at START position (C) during cranking. Release your hand off the key immediately after the engine has been started.

The key in starting switch automatically returns to ON position (B).

REMARK

- At starting of the engine, battery voltage may drop abruptly depending on the ambient temperature or battery condition, and the machine monitor may restart, but it is not a trouble.
- If the lock lever is not at LOCK position (L), the engine does not start.

Check that the lock lever is at LOCK position (L) when operating the starting switch.

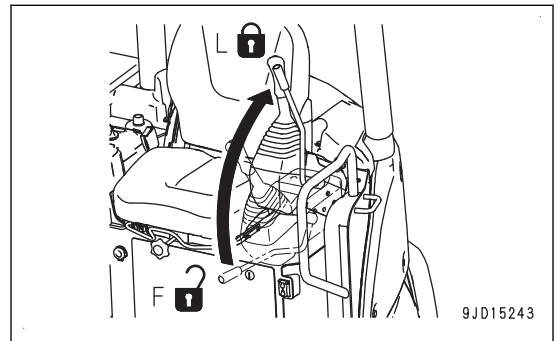
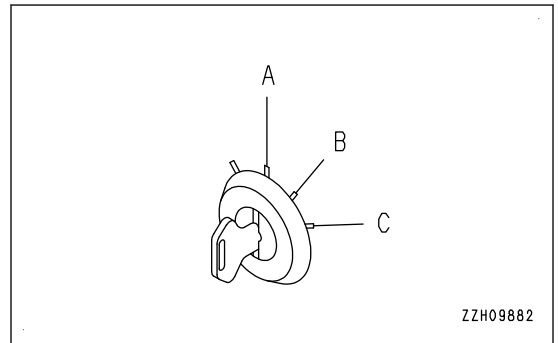

FUEL CONTROL DIAL

Fuel control dial is used to control the engine speed and output.

(a) Low idle (MIN)

The position where the dial is turned fully to the left.

(b) High idle (MAX)

The position where the dial is turned fully to the right.

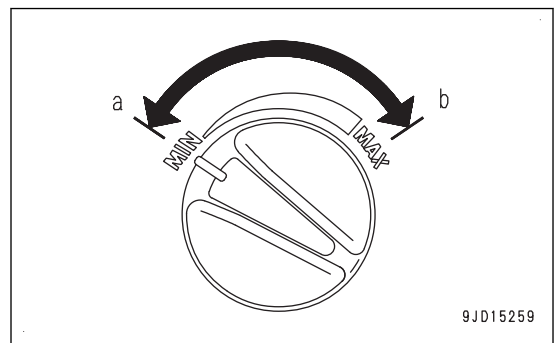

LAMP SWITCH

Lamp switch is used to light up the working lamp and monitor illumination.

(a) Night position

Lamps light up and monitor illumination is set to night mode.

(b) Day position

Lamps light up and monitor illumination is set to day mode.

(c) OFF position

Lamps go out.

(The monitor illumination is set to day mode.)

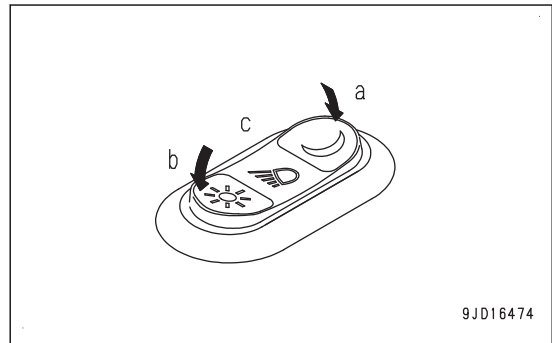

HORN SWITCH

If you press the horn switch, the horn sounds.

Horn switch is located on top of R.H. work equipment control lever.

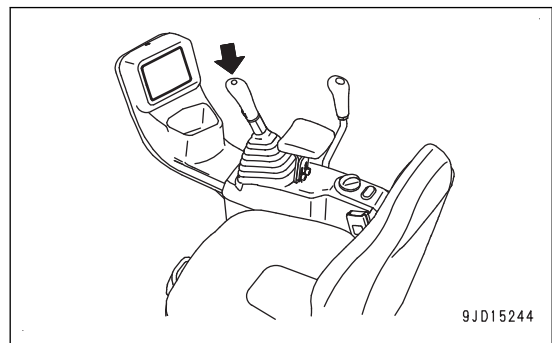

TRAVEL SPEED SELECTOR SWITCH

WARNING

- When loading to or unloading onto/from a trailer, always drive the machine at low speed (set it to Lo), and never operate the travel speed selector switch during travel.
- If the travel speed is switched between high-speed and low-speed while the machine is traveling, the machine may deviate to one side, even when traveling in a straight line. Stop the machine before switching the travel mode.

Perform the setting of speed mode after starting the engine.

Travel speed selector switch is used to switch the travel mode.

Lo display

Low-speed travel

Hi display

High-speed travel

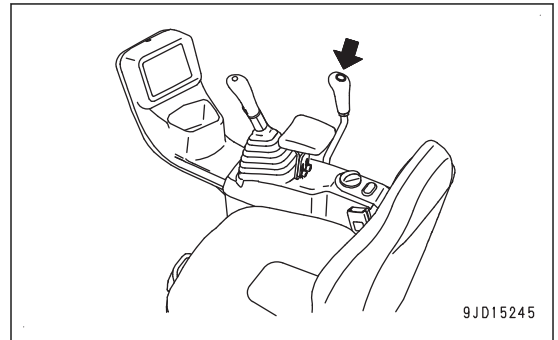

The travel speed is automatically set to low-speed travel (Lo) when the starting switch key is turned to ON position.

Each time the travel speed selector switch is pushed, travel mode changes repeatedly as Lo → Hi → Lo.

Check the travel mode setting at travel speed display on the machine monitor.

While traveling in high-speed travel (Hi), if the traction force is needed in soft ground or on a slope, travel speed automatically changes to low-speed travel (Lo), although high-speed travel (Hi) is lit in travel speed display.

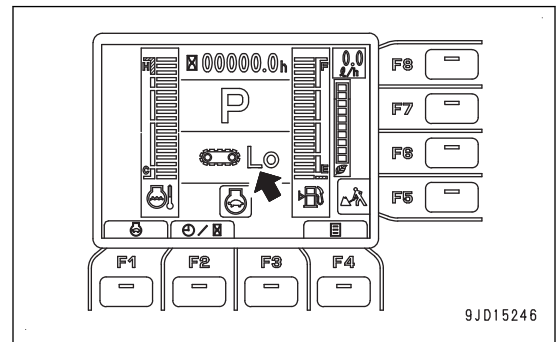

WIPER SWITCH

(Machine with cab specification)

⚠ CAUTION

- Do not keep pressing it for 10 seconds or more at the position of injecting washer fluid.
- Do not press it at the position of injecting washer fluid when the washer tank is empty.

Wiper switch actuates the wiper at the front window glass.

(a) Stop position

The wiper stops.

(b) Wiper and washer position

The wiper operates.

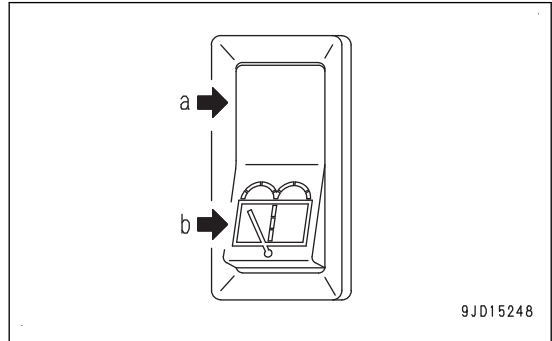

If the wiper and washer position (b) is kept pressed while the wiper is in operation, the injection of the window washer fluid and the wiper operation are performed simultaneously.

If the wiper switch is released, it returns to the wiper and washer position (b), the injection of the window washer fluid stops, and the state becomes that only the wiper is operated.

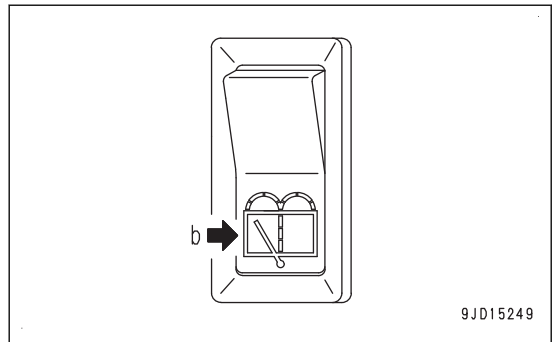

ROOM LAMP SWITCH

(Machine with cab specification)

NOTICE

If the room lamp is left lit on, the batteries may be exhausted. Always turn the switch to OFF position after using room lamp.

Use room lamp switch to light up the room lamp.

It does not light up when the starting switch is at OFF position.

(a), (b) ON position

Lights up

(c) OFF position

OFF

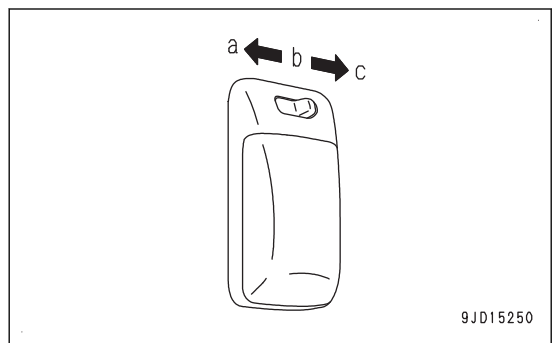

PUMP SECONDARY DRIVE SWITCH

NOTICE

- Use the pump secondary drive switch only in an emergency. Repair the problem as soon as possible.
- If the pump secondary drive switch is moved to “Emergency” position by mistake while the machine is operating normally, “L03” is displayed on the machine monitor.

If “L03” is displayed during operation, press function switch “F3” on the machine monitor, and check whether the current failure code includes any of the hydraulic system errors “DXA8KB” and “DXA8KA”. If there is the hydraulic system error, repair the error as soon as possible.

Check that the pump secondary drive switch is in “NORMAL” position (b). If not, return the switch to “NORMAL” position (b).

When the current failure code includes either of the hydraulic system error “DXA8KB” or “DXA8KA”, the pump secondary drive switch enables you to operate the work equipment or the machine temporarily by turning the switch to EMERGENCY position (a).

(a) EMERGENCY

When abnormal (switch is set to upper position)

(b) NORMAL

When normal (switch is set to lower position)

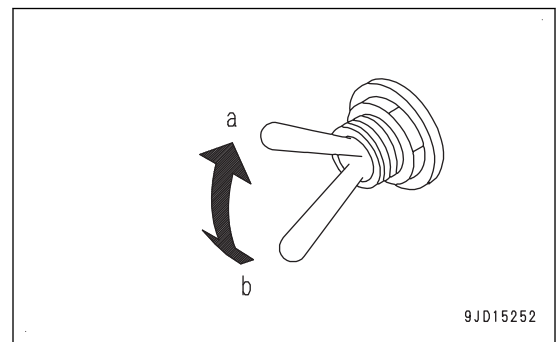
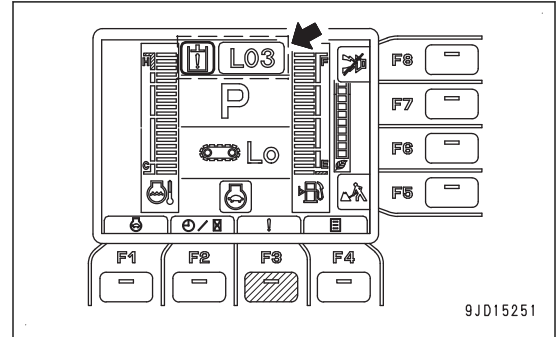

LOCK LEVER AUTOMATIC LOCK CANCEL SWITCH

NOTICE

The lock lever automatic lock cancel switch is used to disable the lock lever automatic lock function and enable the operations of the work equipment and machine temporarily, when the lock lever automatic lock function is abnormal.

Use this switch only when the machine or working machine needs to be moved temporarily in an abnormal and emergency condition. Repair the problem as soon as possible.

If the lock lever automatic lock function is abnormal, when the lock lever is canceled normally under the condition that the work equipment control lever or travel lever is in NEUTRAL position, this function is actuated by mistake and the machine or the work equipment may not move.

The machine or the work equipment can be operated temporarily by setting the lock lever automatic lock cancel switch to cancel position (a).

(a) CANCEL

When abnormal (switch is set to upper position)

(b) NORMAL

When normal (switch is set to lower position)

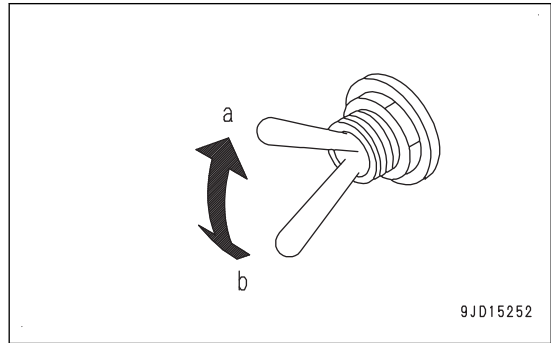

When the lock lever automatic lock cancel switch is set to CANCEL position (a), the lock lever automatic lock cancel pilot lamp lights up.

After moving the machine or work equipment temporarily by operating this switch, stop the engine, return the switch to NORMAL position (b), and then ask your Komatsu distributor for repair.

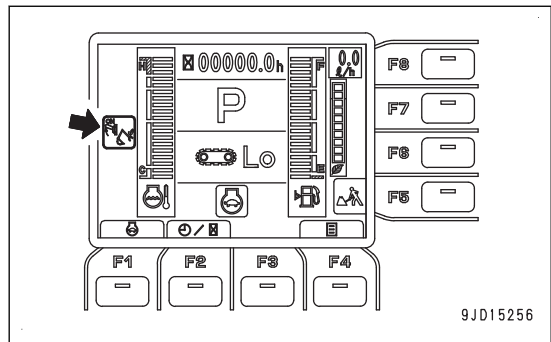

ENGINE SHUTDOWN SECONDARY SWITCH

NOTICE

The engine shutdown secondary switch is used to stop the engine when the starting switch is turned to OFF position but the engine does not stop.

- Use the engine shutdown secondary switch only in an emergency. Ask for repair of the problem part as soon as possible.
- If the engine shutdown secondary switch is moved to “ENGINE STOP” position by mistake while the machine is operating normally, “Engine Shutdown Secondary SW in Operation” is displayed on the machine monitor.
If “Engine Shutdown Secondary SW in Operation” is displayed on the machine monitor, check that the cover of engine shutdown secondary switch is closed and the switch is in “NORMAL” position. If not, set it to “NORMAL” position.

1. Raise cover (1) and open it.

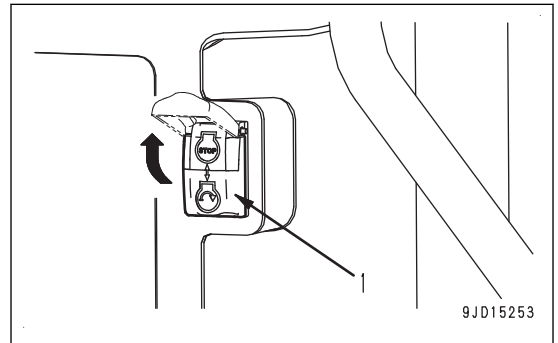

2. Turn the engine shutdown secondary switch to “ENGINE STOP” position (a) and the engine stops.

(a) ENGINE STOP

When abnormal (switch is set to upper position)

(b) NORMAL

When normal (switch is set to lower position)

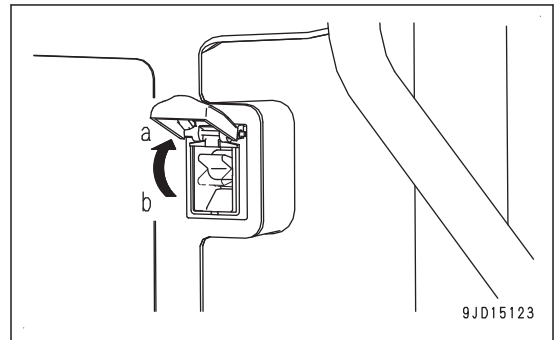

- When cover (1) is closed, the engine shutdown secondary switch automatically returns to “NORMAL” position (b).
- When the starting switch is turned to ON position while the engine shutdown secondary switch is in “ENGINE STOP” position (a), “Engine Shutdown Secondary SW in Operation” is displayed on the machine monitor.

If this screen is displayed, return the engine shutdown secondary switch to “NORMAL” position (b).

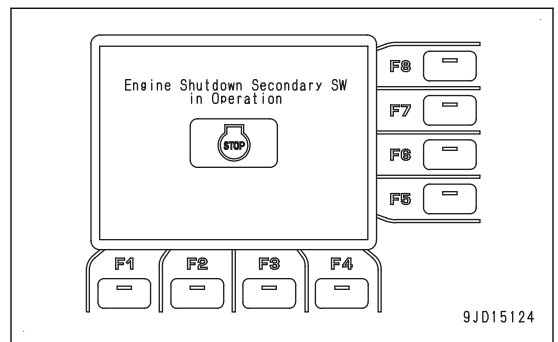

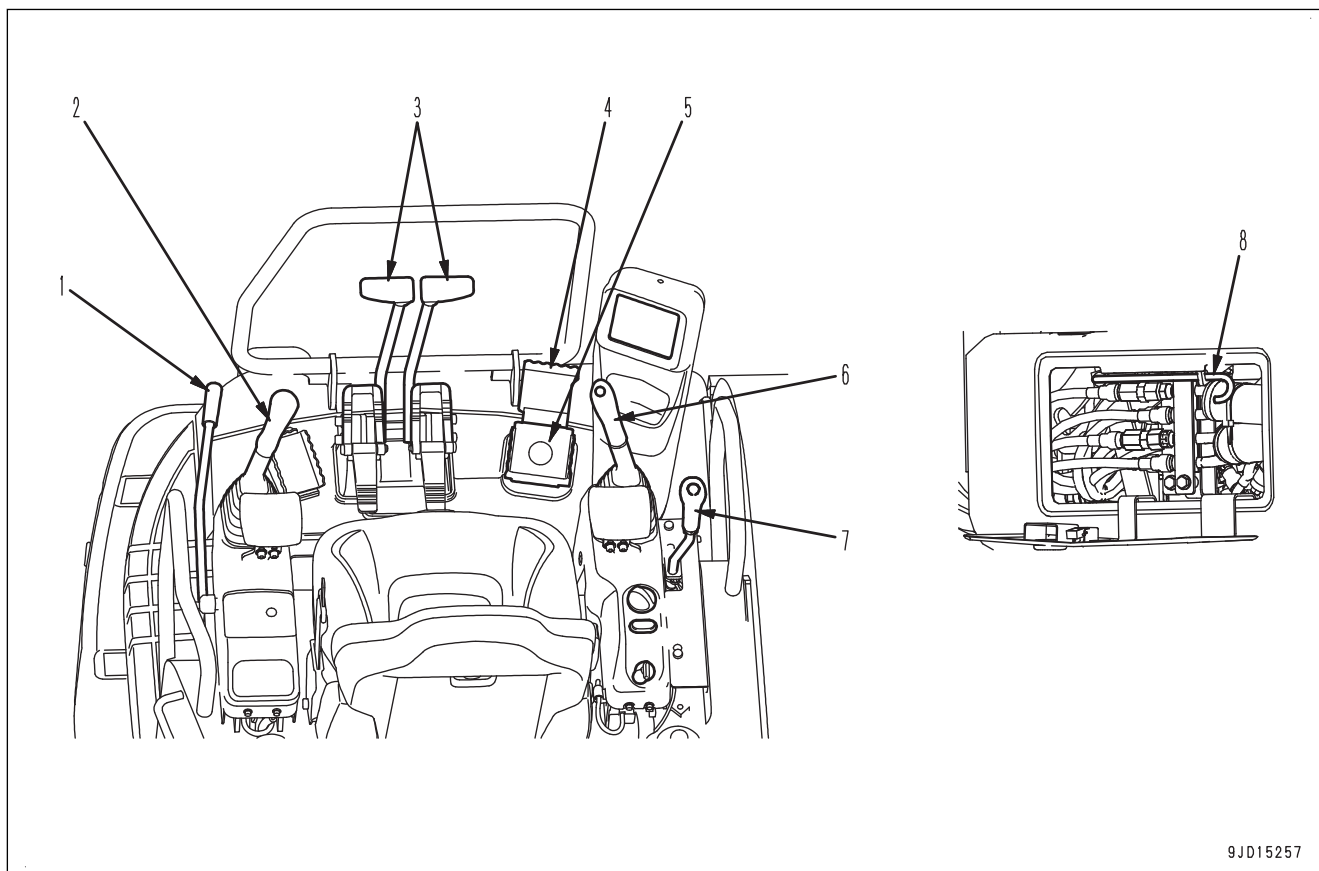
CONTROL LEVERS AND PEDALS

- (1) Lock lever
- (2) L.H. work equipment control lever
- (3) Travel lever (with pedal)
- (4) Swing lock cover
- (5) Boom swing control pedal
- (6) R.H. work equipment control lever
- (7) Blade control lever
- (8) Floor lock release lever

9JD15257

LOCK LEVER

⚠ WARNING

- When leaving the operator's seat, set the lock lever securely to **LOCK** position. If the lock lever is not at **LOCK** position and the control levers, control pedals, and attachment control pedals are touched by mistake, it may lead to serious personal injury or death.
- Always check that the lock lever is in **LOCK** position.
- When pulling up or pushing down the lock lever, be careful not to touch the work equipment control lever. Check that your clothes do not get caught by the work equipment control lever.
- Before setting the lock lever to **FREE** position, make sure that all control levers and control pedals are set to **NEUTRAL** position. If any of them is out of **NEUTRAL** position, the work equipment or machine may move suddenly and cause a serious personal injury or death.

The lock lever is a device to lock the work equipment, swing, travel, and attachment control levers.

Be sure to operate the lock lever by the operating portion on the top.

By pulling up the lock lever, lever stand flips up to lock.

(L) LOCK position

Even if any of control lever, control pedal, or attachment control pedal is operated, machine does not move.

(F) FREE position

The operator can operate the machine by operating the control levers, control pedals, and attachment control pedals.

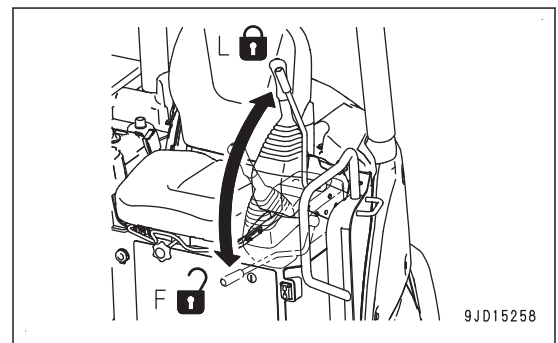

Automatic lock function of lock lever

⚠ WARNING

- The lock lever automatic lock function assists the operator in judgment to reduce damage caused by accident. It is not a device to stop the work equipment or machine in all situations.
- Even if the lock lever automatic lock function works, the work equipment or machine may not stop immediately or may stop after moving by a certain distance. The lock lever automatic lock function may not work in the following cases. Accordingly, do not rely on it too much.
 - When the hydraulic oil temperature is low
 - When the viscosity of the hydraulic oil used is higher than that of the genuine hydraulic oils which Komatsu recommends
 - When the system has a problem
- Before setting the lock lever to **FREE** position, make sure that all control levers and control pedals are set to **NEUTRAL** position. If any of them is out of **NEUTRAL** position, the work equipment or machine may move suddenly and cause a serious personal injury or death.

The lock lever automatic lock function automatically sets the lock lever in the locked state to prevent the work equipment or machine from operating continuously when the lock lever is set to **FREE** position while the work equipment control lever or travel lever is operated.

When the lock lever automatic lock function works, the operations of the work equipment, swing, travel, and attachment are locked automatically. Even if any of control lever, control pedal, or attachment control pedal is operated while the lock lever is in **FREE** position, the machine does not move.

While the lock lever automatic lock function is being actuated, the display pops up, and the guidance icon on the right bottom lights up in red.

If you press the function switch “F4”, the screen changes to “Lock Lever Auto Locked” screen and you can check the state.

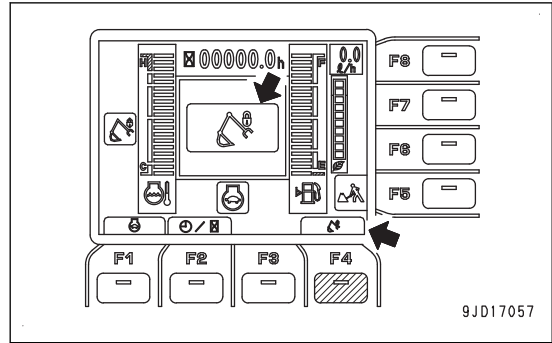

If you press the function switch “F3” on “Lock Lever Auto Locked” screen, the screen returns to the pop-up display screen of it.

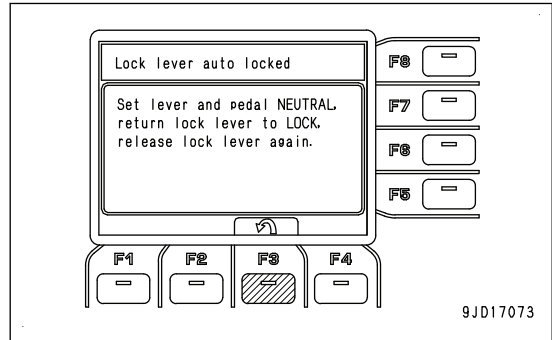

To cancel the lock lever automatic lock function, return the lock lever to LOCK position (L) according to “Lock Lever Auto Locked” screen, check that all control levers, control pedals, and attachment control pedals are in NEUTRAL position, and then set the lock lever to FREE position (F) again.

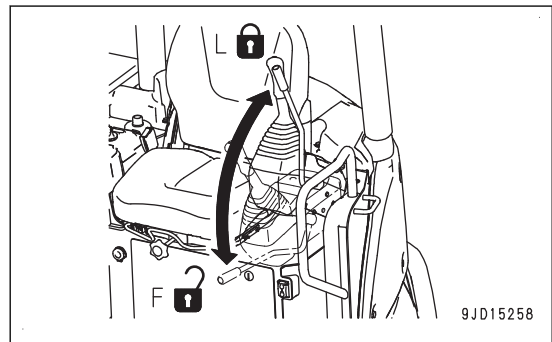

TRAVEL LEVER

⚠ WARNING

- If you perform operations with your foot on the pedal, the machine may suddenly start if you depress the pedal by mistake, and this may lead to serious personal injury or death.
Be extremely careful when using the pedal for travel and steering operations, and do not put your foot on the pedal when it is not necessary.
- When the track frame is facing the rear, the direction of operation of the steering lever is the opposite to the direction of movement of the machine (forward/reverse, right/left turn).
When operating the travel lever, always check if the track frame is facing the front or the rear.
(If sprocket (A) is at the rear, the track frame is facing the front.)
- When entering to the operator's seat, there is a danger that your toe may get caught on the travel pedal.
When you do not perform the pedal operation, always fold the pedals.
When you perform the pedal operation, sit on the operator's seat, and then unfold the pedals to use them.
After performing the pedal operation, always fold the pedals while sitting on the operator's seat.

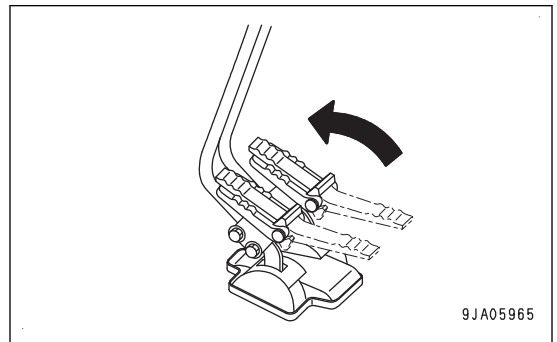
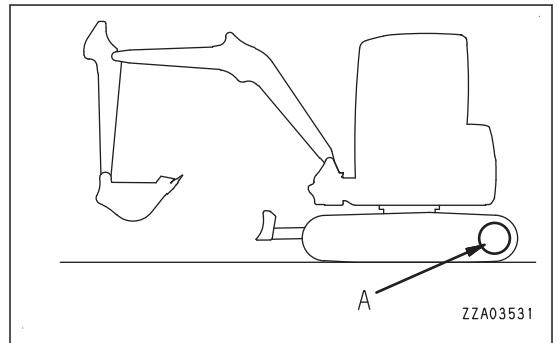

The travel lever is used to change the direction of travel between forward and reverse.

() shows the pedal operation.

(a) FORWARD

The lever is pushed forward
(The front side of pedal is depressed)

(b) REVERSE

The lever is pulled back
(The rear side of pedal is depressed)

(N) NEUTRAL

The machine stops.

REMARK

If the lever is shifted to FORWARD or REVERSE position from NEUTRAL position, the alarm sounds to warn that the machine is starting to move.

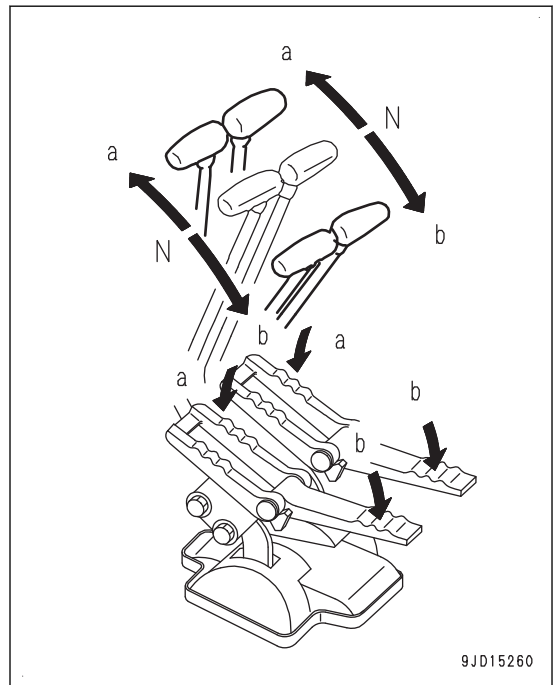

BLADE CONTROL LEVER

NOTICE

If you continue the digging operation with blade for 1 hour or more, be careful about increase of the engine coolant temperature.

The blade control lever is used to operate the blade.

(a) Blade LOWER

The blade control lever is pushed forward.

(b) Blade RAISE

The blade control lever is pulled back.

(N) NEUTRAL

Blade is held at current position.

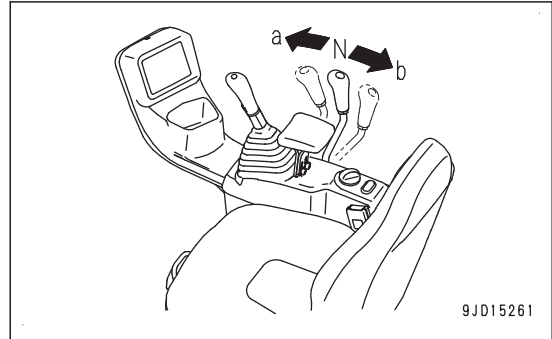

9JD15261

SWING LOCK COVER

⚠ WARNING

When you do not perform the boom swing operation, lock the swing with the swing lock cover. If it is not locked and the control pedal is touched by mistake, this may cause a serious injury or death.

The swing lock cover is used to lock the boom swing control pedal.

When the boom swing control pedal is covered with the swing lock cover, the boom swing control pedal is locked.

(F): FREE position

You can swing the boom to the right and left by operating the boom swing control pedal.

(L): LOCK position

You cannot operate the boom swing control pedal.

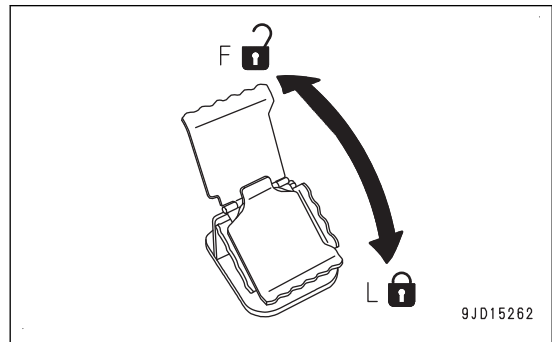

9JD15262

BOOM SWING CONTROL PEDAL

Boom swing control pedal is used to swing the boom.

(a) Swing RIGHT

Depress right of the boom swing control pedal.

(b) Swing LEFT

Depress left of the boom swing control pedal.

(N) NEUTRAL

Boom is held at current position.

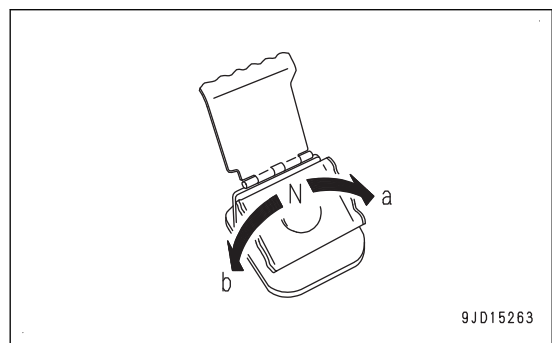

9JD15263

FLOOR LOCK RELEASE LEVER

WARNING

- When opening and closing cab or floor, observe the warning and precautions for the work. Wrong operation may cause serious personal injury or death.
- Do not open and close the cab or floor when the machine is on a slope.
- Do not open and close the cab or floor in strong winds.

Open and close the cab or floor while pulling the floor lock release lever.

Pull the floor lock release lever to FREE position (F) and lock is released.

Release the floor lock release lever and it automatically returns to LOCK position (L), and floor is locked.

(F) FREE position

The position where the floor lock release lever is pulled back

(L) LOCK position

The position where the floor lock release lever is pushed forward fully

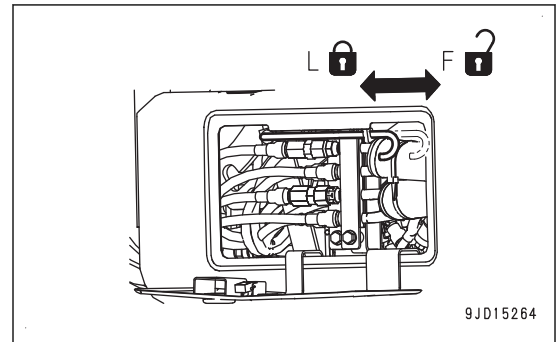

WORK EQUIPMENT CONTROL LEVER

⚠ WARNING

- The control pattern is set to the standard control method (ISO pattern).
- If it is necessary to change the control pattern, ask your Komatsu distributor.
- The operations in the control patterns other than the ISO pattern are explained in "Attachments and options". Be sure to read and understand them before starting the operation.
- When changing the control pattern, replace the control pattern plate with one matching to the operation of the machine as well.

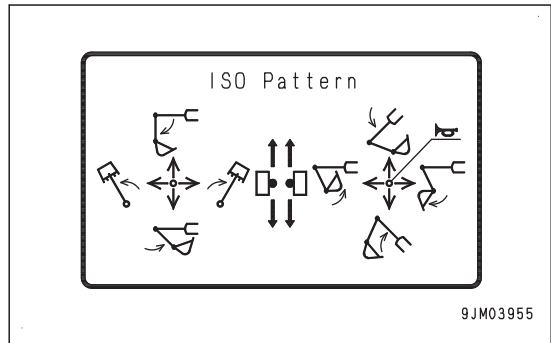

The control pattern card is located at the position shown in the figure.

Machine with canopy specification

The control pattern card is located on the right side of the operator's seat.

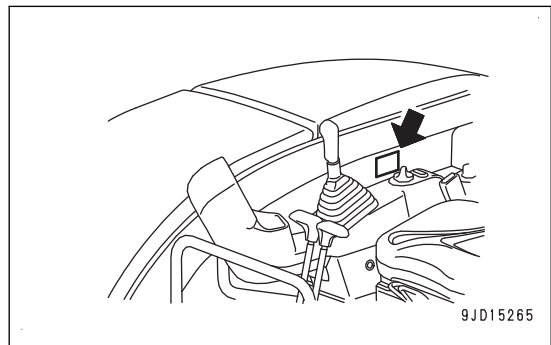

Machine with cab specification

The control pattern card is located on the right side of the operator's seat.

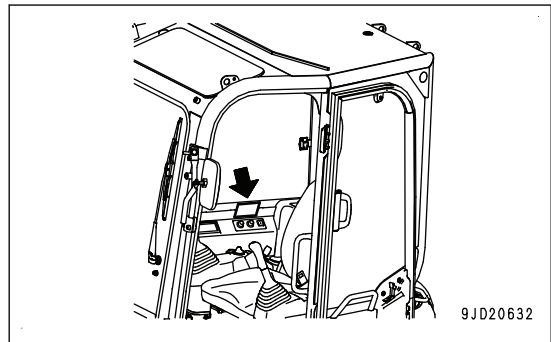

The L.H. work equipment control lever is used to operate the arm and upper structure.

Swing operation

- (a): Swing RIGHT
- (b): Swing LEFT

Arm operation

- (c): Arm IN
- (d): Arm OUT

(N) NEUTRAL

The upper structure and arm are held in position and do not move.

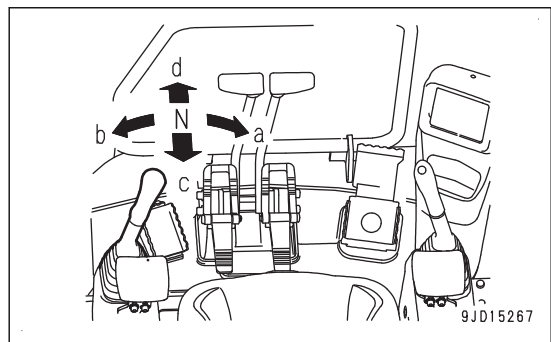

The R.H. work equipment control lever is used to operate the boom and bucket.

Boom operation

(e): Boom RAISE

(f): Boom LOWER

Bucket operation

(g): Bucket DUMP

(h): Bucket CURL

(N) NEUTRAL

The boom and bucket are held in position and do not move.

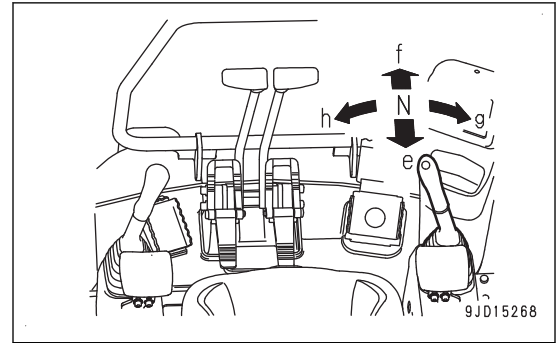

OTHER EQUIPMENT

METHOD FOR OPENING AND CLOSING CAB FRONT WINDOW

(Machine with cab specification)

⚠ WARNING

- When opening or closing the front window and door, etc., always set the lock lever to LOCK position. If the lock lever is at FREE position and the control lever, control pedal, or control switch is touched by mistake, it may cause serious personal injury or death.
- When opening or closing the front window, stop the machine on a level ground, lower the work equipment to the ground, stop the engine, and then perform the work.
- When opening the front window, hold the handle firmly with both hands and lift it up. Do not release your hands until the window is fixed.
- When closing the front window, the window may move quicker under its own weight. Hold the handles securely with both hands when closing it.

It is possible to stow the front window (upper side) in the roof of the operator's compartment.

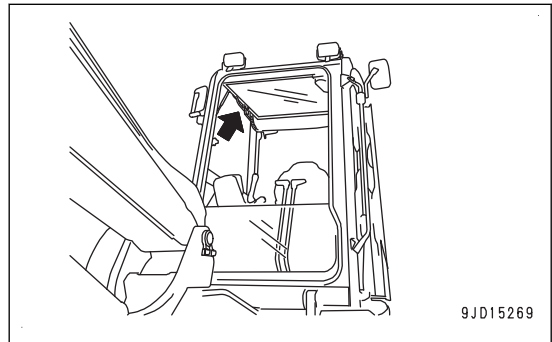

PROCEDURES FOR OPENING UPPER CAB FRONT WINDOW

1. Stop the machine on a level ground, lower the work equipment to the ground, then stop the engine.
2. Set the lock lever securely to LOCK position (L).
Be sure to operate the lock lever by the operating portion on the top.

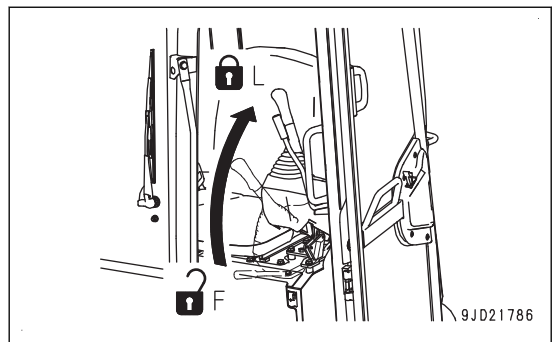

3. Hold the right and left handles (1) at the center part of front window (inside).
When holding the handle (1), put your thumb on the handle lock (2).

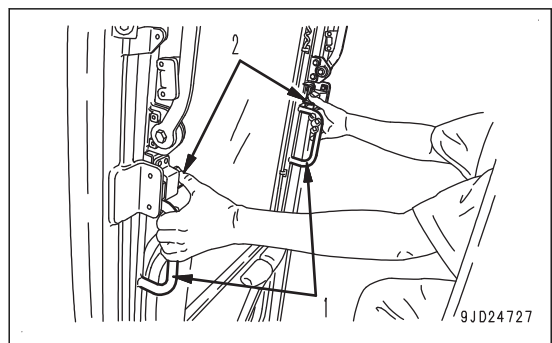

4. While pushing down the handle locks (2) with your thumb, pull the right and left handles (1) backward to open the front window.

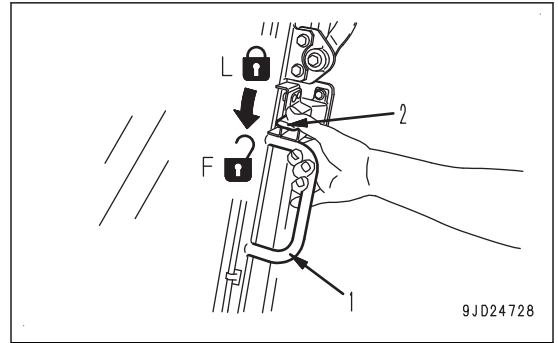

5. Hold the right and left handles (1), and pull up the front window backward slantwise.

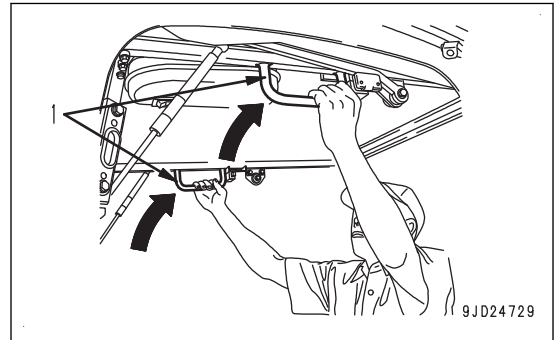

6. When it does not move any more to the rear side of cab, push the right and left handles (1) upward and fix the front window securely.

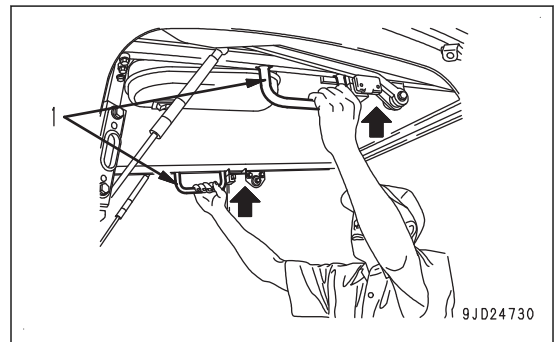

7. Check that the handle locks (2) are securely fixed.
 When pushing the handles (1) upward, check that the handle locks (2) move toward FREE position (F) once and then return to LOCK position (L).
 If they are not fixed, repeat procedure from step 5 until they are fixed.

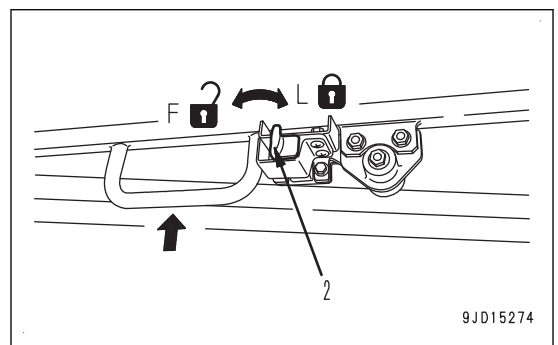

PROCEDURES FOR CLOSING UPPER CAB FRONT WINDOW

⚠ CAUTION

When closing the front window (upper side), lower it slowly and be careful not to get your hand caught.

1. Stop the machine on a level ground, lower the work equipment to the ground, then stop the engine.
2. Set the lock lever securely to LOCK position (L).

Be sure to operate the lock lever by the operating portion on the top.

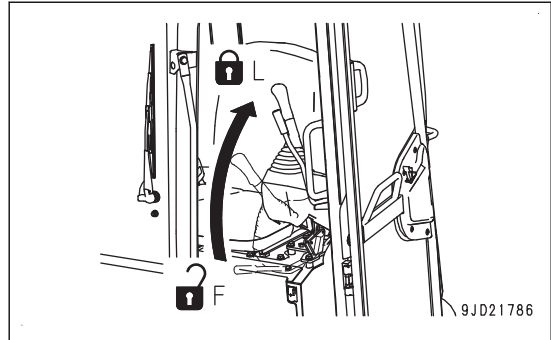

3. Hold the right and left handles (1) at the center part of front window (inside). When holding the handle (1), put your thumb on the handle lock (2).
4. While pushing the handle locks (2) forward with your thumb, pull down the right and left handles (1) to open the front window.
5. Hold the right and left handles (1), and lower the front window slowly forward slantwise.

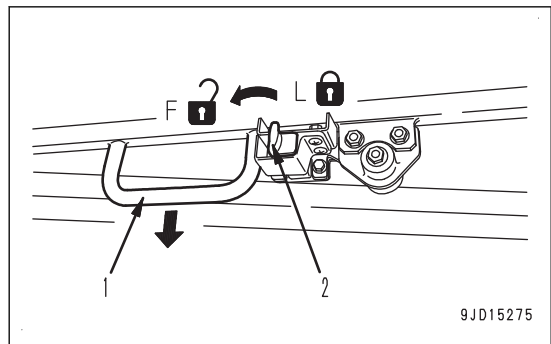

6. When the bottom of the window touches to the top of lower window, push the right and left handles (1) forward, and push them against the right and left stoppers (3) to fix them securely.

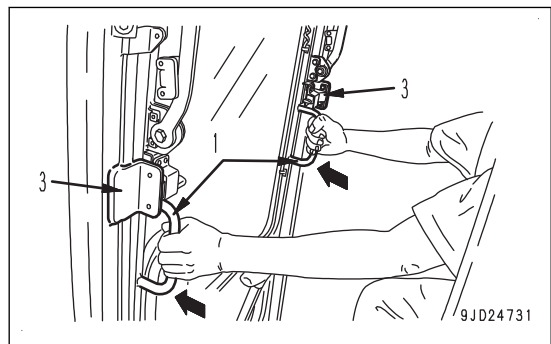

7. Check that the handle locks (2) are securely fixed. When pushing the handles (1) forward, check that the handle locks (2) move toward FREE position (F) once and then return to LOCK position (L).

If they are not fixed, repeat procedure from step 5 until they are fixed.

REMARK

When lock (4) is in front of stopper (3), you can judge that it is fixed.

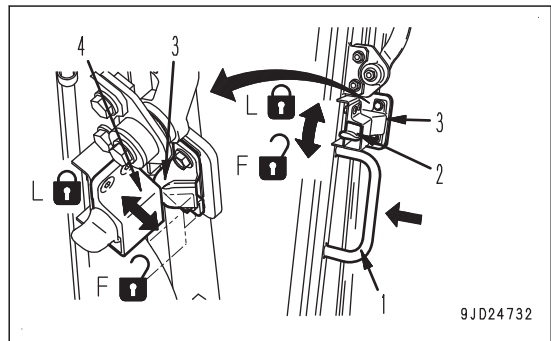

SLIDE WINDOW

(Machine with cab specification)

CAUTION

Keep your hand or head inside the window when driving or operating the machine.

The window at the right side of cab is sliding type small window, and you can open or close it.

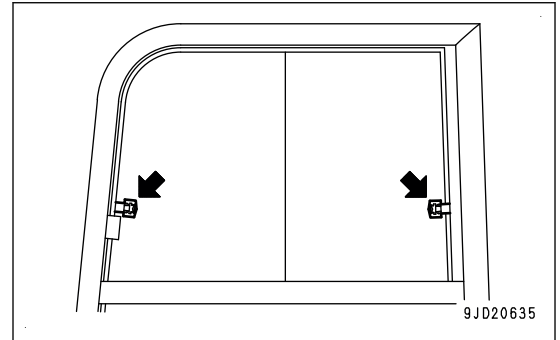

EMERGENCY ESCAPE HAMMER

(Machine with cab specification)

CAUTION

- If it is necessary to break the window glass with the hammer, be extremely careful not to get injured with scattered pieces of broken glass.
- To prevent injury, remove the broken pieces of glass remaining in the frame before escaping through the window. Be careful also not to slip on the broken pieces of glass.

Hammer is provided to break the glass. Escape through the window in case of emergency when you cannot open the cab door.

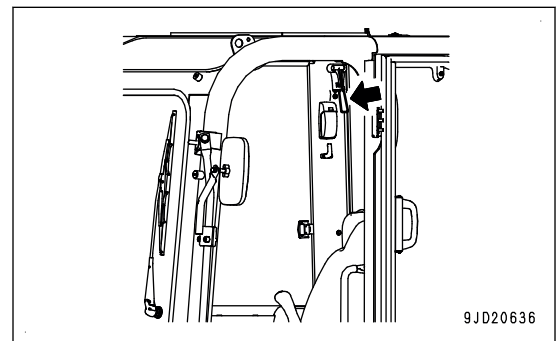

To escape from the operator's cab, use hammer to break the glass and escape through the window.

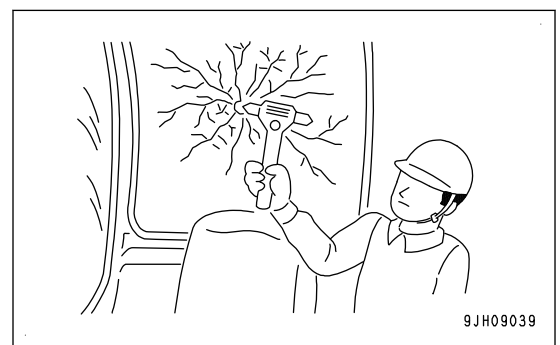

CAB DOOR

⚠ CAUTION

- Cab door must be checked to be locked either at the open position or closed position.
- Always place the machine on a level ground when opening or closing the cab door. Avoid opening or closing the door on a slope, since there is a danger that the operating effort may suddenly change.
- Hold the door handle and knob whenever opening or closing the cab door.
- Be careful not to get your hands caught between the front pillar or center pillar.
- When there is anyone inside the cab, always call out a warning before opening or closing the door.

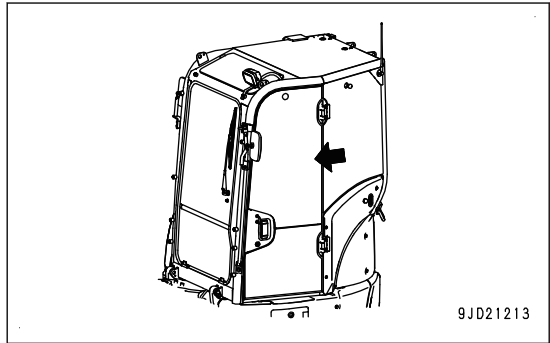

CAB DOOR HANDLE

Pull the cab door handle (1) while it is not locked, and the door opens to the full open position.

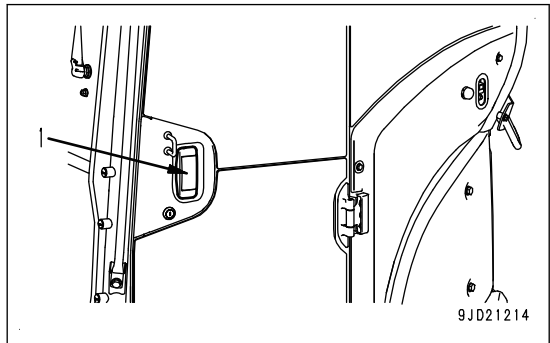

OPEN KNOB FOR CAB DOOR

Pull the open knob for the cab door, and the cab door opens to the full open position.

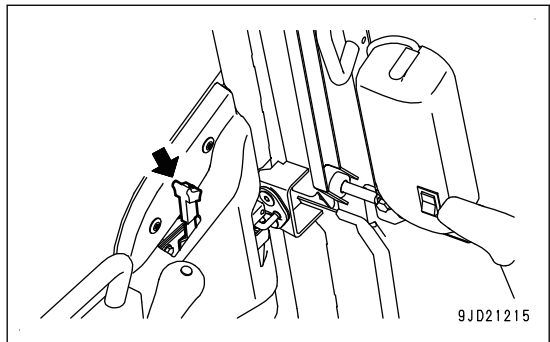

OPEN LOCK FOR CAB DOOR

Use this to fix the cab door in position after opening it or when getting in and out the machine.

1. Push the cab door against the catch part (1) to lock it in position.

Fix the cab door against the catch part (1) securely.
When getting on or off the machine, hold the inside hand-rail.

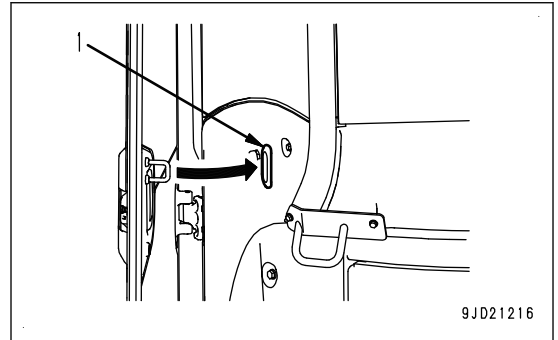

2. To close the cab door, push down the release knob (2).
Catch (1) is released.

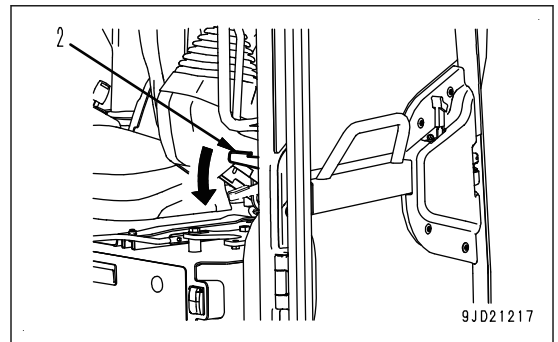

CUP HOLDER

CUP HOLDER: CANOPY SPEC

The cup holder is located on the rear right of the operator's seat.

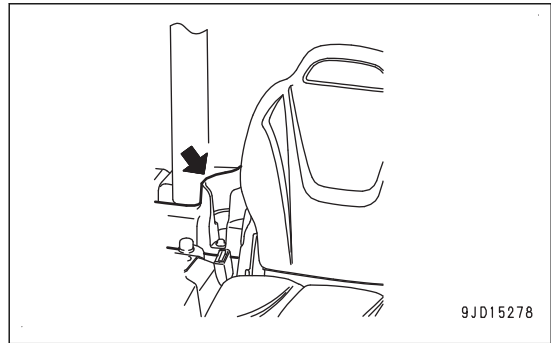

CUP HOLDER: CAB SPEC

The cup holder is located on the rear left of the operator's seat.

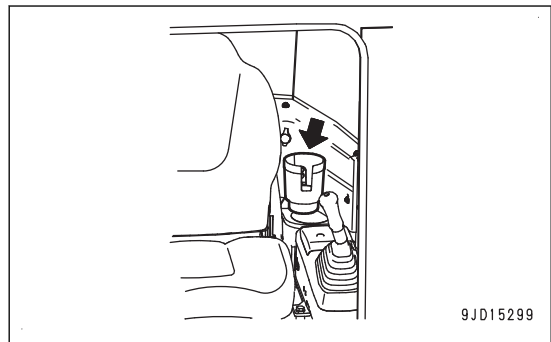

ASHTRAY

(Machine with cab) (if equipped)

An ashtray is located on the right side of the operator's seat.

It is magnet type, so you can install it to appropriate place each time.

Always extinguish your cigarette before putting it in the ashtray, and be sure to close the lid.

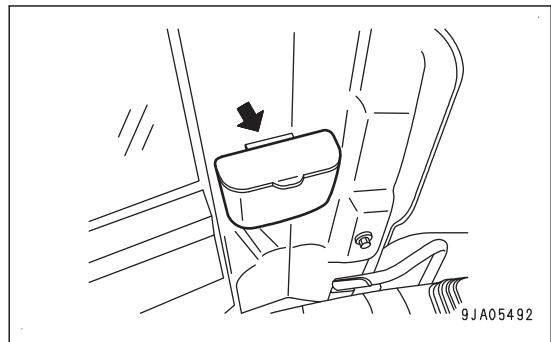

METHOD FOR OPENING AND CLOSING FLOOR UNIT

⚠ WARNING

When opening and closing the floor, observe the following warning and precautions for the work.

Wrong operation may cause serious personal injury or death.

- Do not open or close the floor when the machine is on a slope.
- Do not open and close the floor in strong winds.
- Immediately after the engine is stopped, its parts and oil are still very hot and may cause burn injury. Check that the temperature inside of engine compartment has been dropped before performing the opening or closing of floor.
- Do not stand on the floor or enter into the cab while floor is open.
- While opening or closing the floor, do not enter under the floor.
- Do not start the engine while floor is open.
- If any damage or problem is found at the floor opening lock part, stop the work, close the floor, and then ask your Komatsu distributor for repair.
- Do not remove the floor mounting bolts (A). The floor may jump up unexpectedly and it is dangerous.

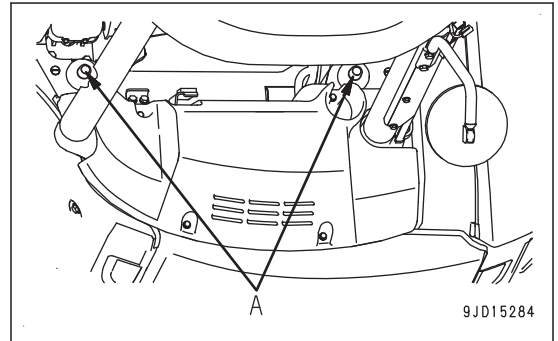

Set the machine to the following conditions before opening the floor.

1. Set the machine in the posture shown in the figure.
 - 1) Start the engine, and run it at low speed.

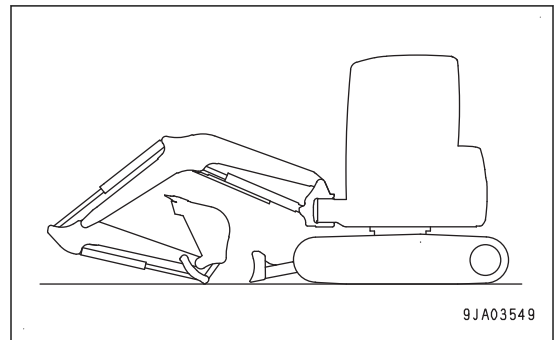

- 2) Set the lock lever to FREE position (F).
Be sure to operate the lock lever by the operating portion on the top.
- 3) Push the blade control lever forward to lower the blade to the ground.
- 4) Operate the work equipment control levers to extend bucket cylinder and arm cylinder to their stroke end, and then lower the boom gently.
Lower the bucket link to the ground.

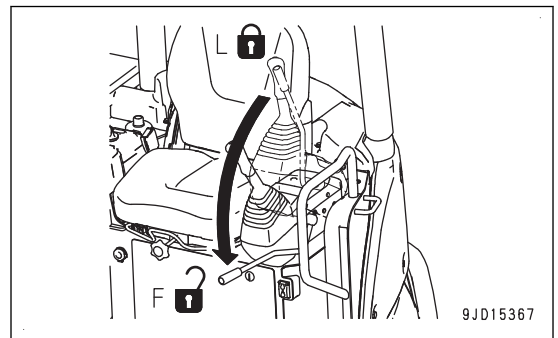

- 5) Set the lock lever to LOCK position (L).
Be sure to operate the lock lever by the operating portion on the top.

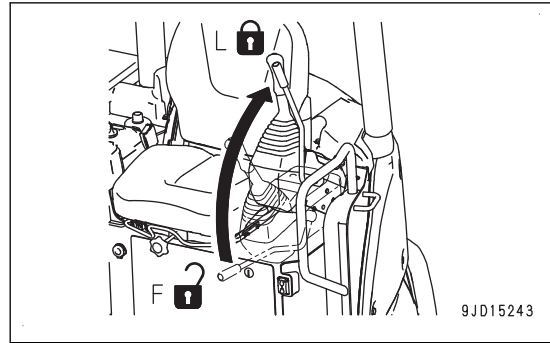

2. Put the wooden blocks on the front and rear sides of the tracks so that the machine does not move.

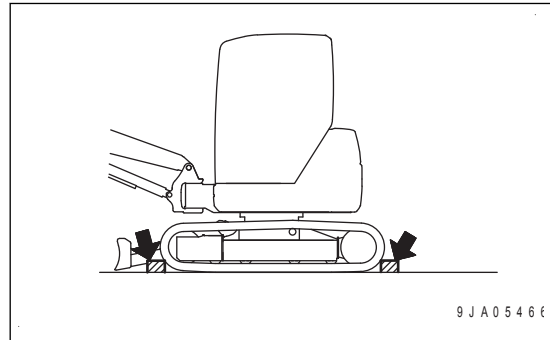

METHOD FOR OPENING FLOOR UNIT**METHOD FOR OPENING FLOOR UNIT: CANOPY SPEC**

1. Remove the triangle cover fixing bolts (1) (M10, 3 pieces), and remove the triangle cover (2).

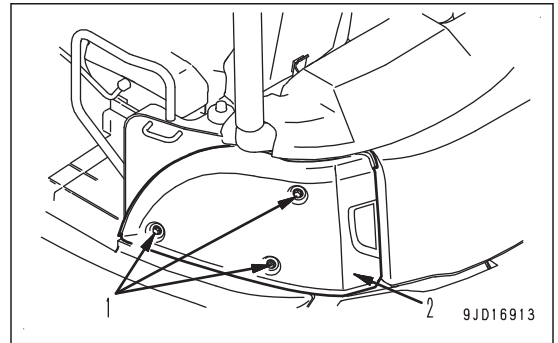

2. Remove the cover fixing bolts (3) (M8, 4 pieces), and remove the cover (4).

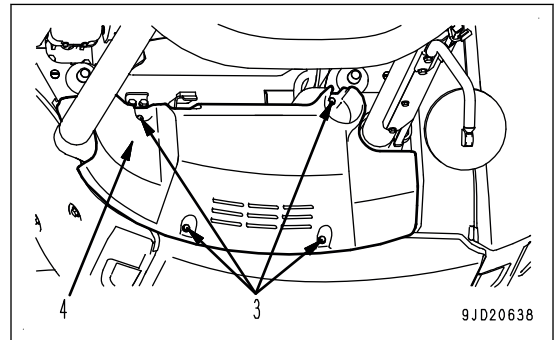

3. Remove the floor tilt fixing bolts (5) (M14, 2 pieces).

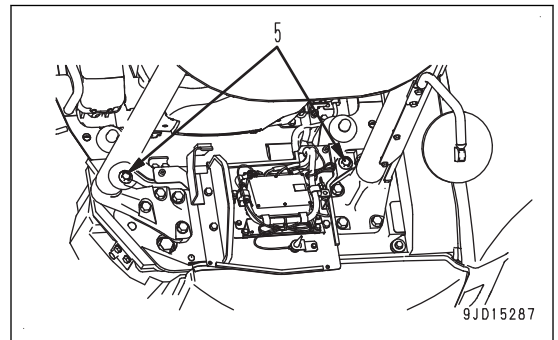

4. Pull the engine rear cover (6) backward to open it.
Open the engine rear cover (6) fully and it is secured by rod (7).

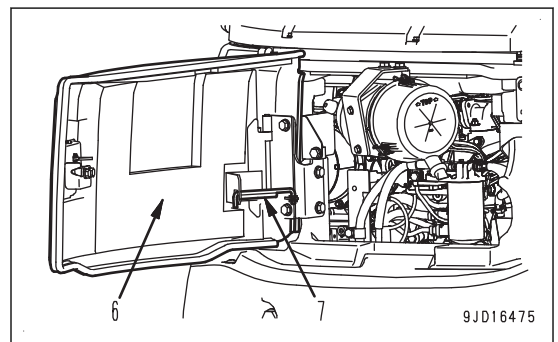

5. Remove the floor tilt fixing bolt (8) (M14, 1 piece).
6. Close the engine rear cover (6).

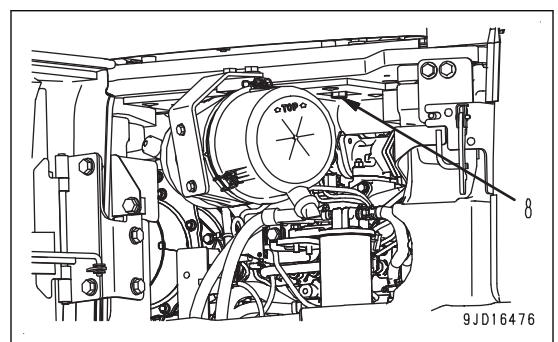

7. Open the inspection window (9).

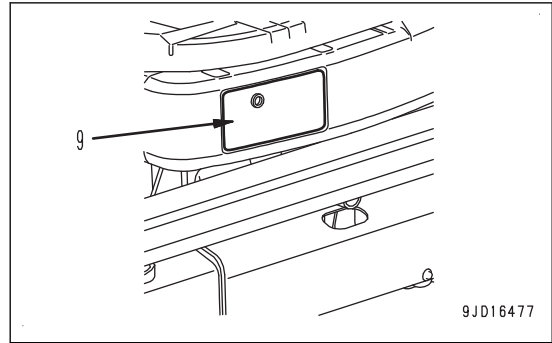

8. While pulling the floor lock release lever (10) to FREE position (F) with your left hand, hold the handle (11) with your right hand and push it up to the direction of arrow (approximately 45 °) to release the floor lock.

9. Hold the handle (11) and push it up to the direction of arrow (approximately 45 °) to raise the floor.

REMARK

- If the floor does not rise, the release lever is not in RELEASE position. Pull back the handle with your right hand, and repeat the preceding procedure again.
- Since the gas spring assists the opening of floor, the force to push up the floor decreases in the following cases. Take care.
 - When the outside air temperature is low
 - When the force of gas spring decreases due to the long-term operation

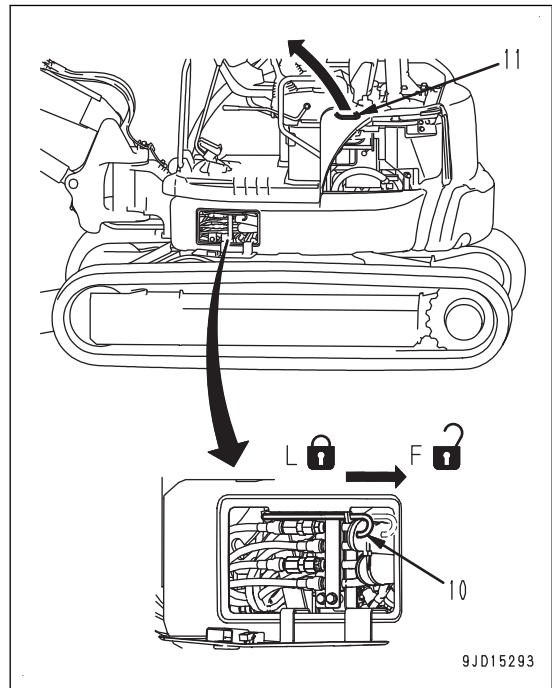

10. Once the floor rises, push it up until the lock pin (12) reaches to the locking notch (14) of lock plate (13).

When the lock pin (12) moves into the locking notch (14), the first lock is fixed.

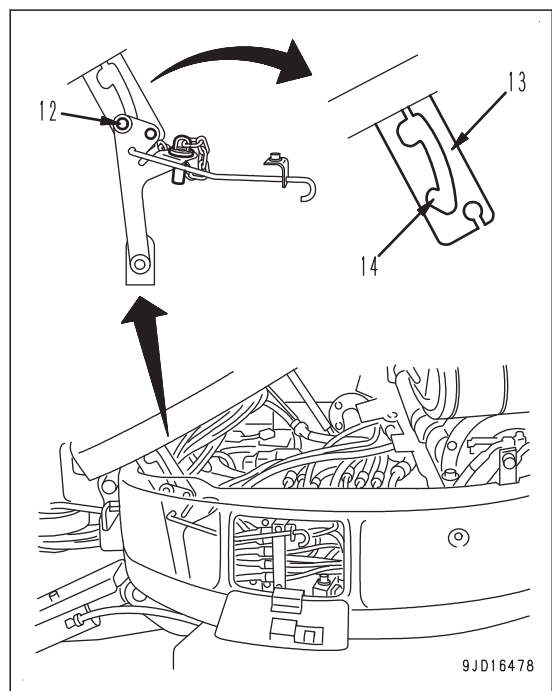

11. Insert the second lock pin (15) into the locking hole (16) securely from inside.
12. Turn the lock pin (15) until its upper part (hook to prevent from coming off) catches the pin (17) of inserting part securely.

NOTICE

Check that the lock pin securely catches the pin and the pin does not come off.

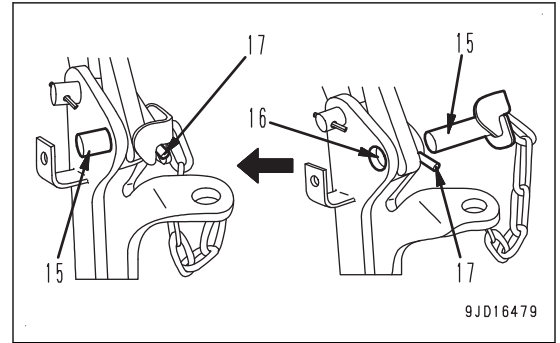

The second lock is fixed, and the floor opening work is completed.

METHOD FOR OPENING FLOOR UNIT: CAB SPEC

1. Remove the triangle cover fixing bolts (1) (M10, 3 pieces), and remove the triangle cover (2).

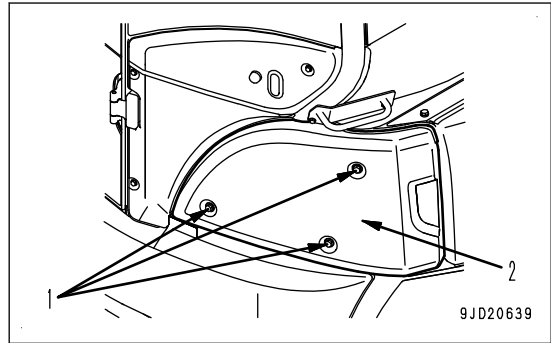

2. Remove the floor tilt fixing bolts (3) (M14, 2 pieces).

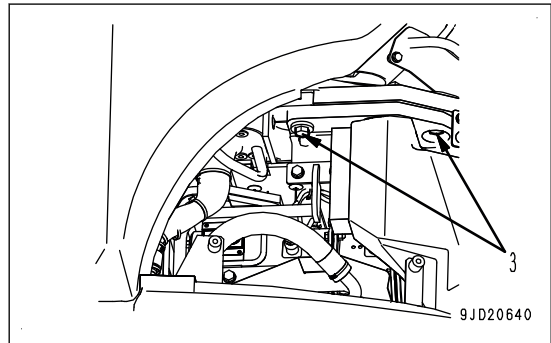

3. Pull the engine rear cover (4) backward to open it. Open the engine rear cover (4) fully and it is secured by rod (5).

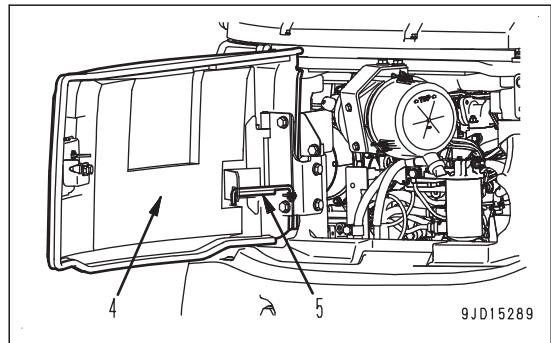

4. Remove the floor tilt fixing bolts (6) (M14, 4 pieces).

REMARK

If the floor tilt fixing bolts (6) are hard to be removed, remove the bolts (A) of air cleaner mounting bracket to move the air cleaner downward.

5. Close the engine rear cover (4).

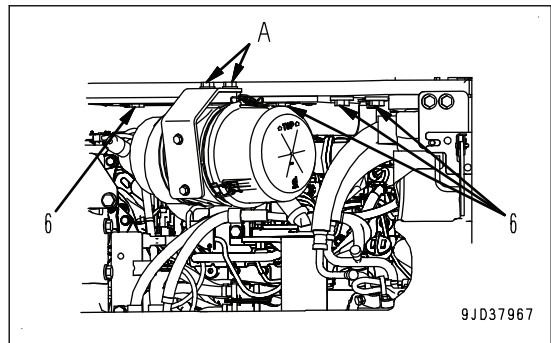

6. Open the inspection window (7).

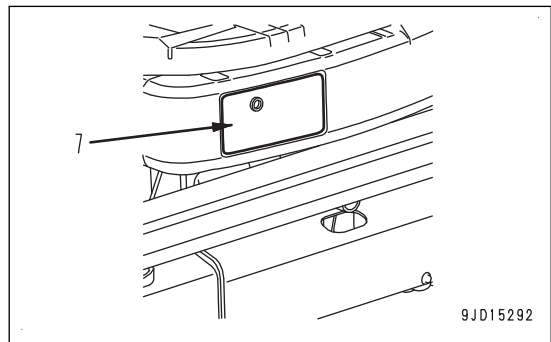

7. While pulling the floor lock release lever (8) to FREE position (F) with your left hand, hold the handle (9) with your right hand and push it up to the direction of arrow (approximately 45 °) to release the floor lock.
8. Hold the handle (9) and push it up to the direction of arrow (approximately 45 °) to raise the floor.

REMARK

- If the floor does not rise, the release lever is not in RELEASE position.
Pull back the handle with your right hand, and repeat the preceding procedure again.
- Since the gas spring assists the opening of floor, the force to push up the floor decreases in the following cases. Take care.
 - When outside air temperature is low
 - When the force of gas spring decreases due to the long-term operation

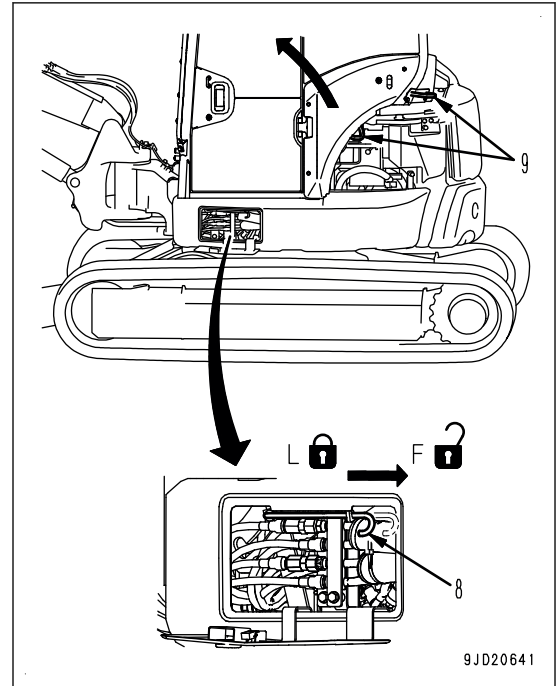

9. Once the floor rises, push it up until the lock pin (10) reaches to the locking notch (12) of lock plate (11).
When the lock pin (10) moves into the locking notch (12), the first lock is fixed.

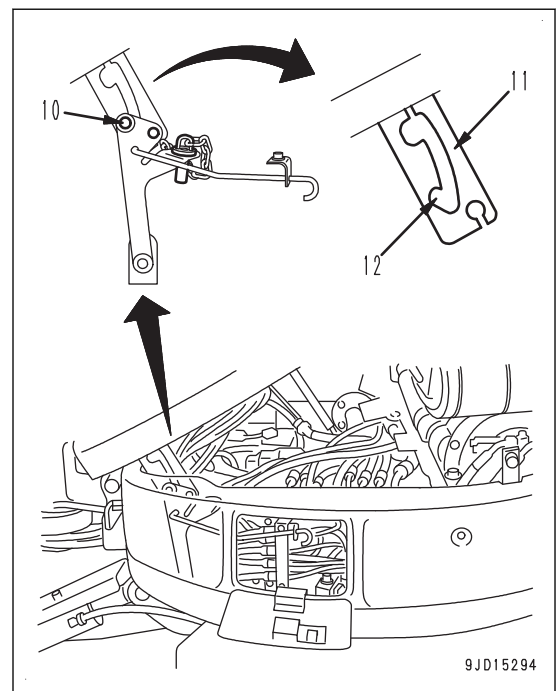

10. Insert the second lock pin (13) into the locking hole (14) securely from inside.
11. Turn the lock pin (13) until its upper part (hook to prevent from coming off) catches the pin (15) of inserting part securely.

NOTICE

Check that the lock pin securely catches the pin and does not come off.

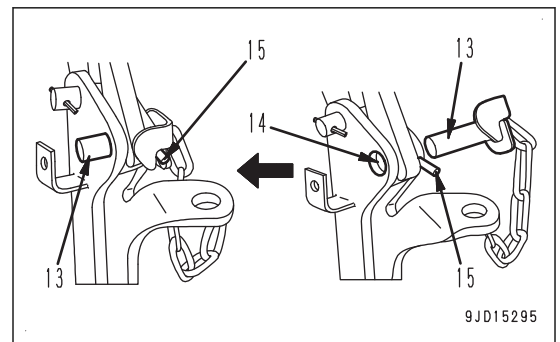

The second lock is fixed, and the floor opening work is completed.

METHOD FOR CLOSING FLOOR UNIT

NOTICE

Before closing the floor, check the wiring harness, piping, and seat inside floor and in the revolving frame for damage or problem.

If any damage or problem is found, ask your Komatsu distributor for repair.

METHOD FOR CLOSING FLOOR UNIT: CANOPY SPEC

1. Remove the lock pin (15) of second lock, and insert it into holder hole (18).

If it is hard to remove the lock pin (15), hold the handle (11) and while pulling it up, remove the lock pin (15).

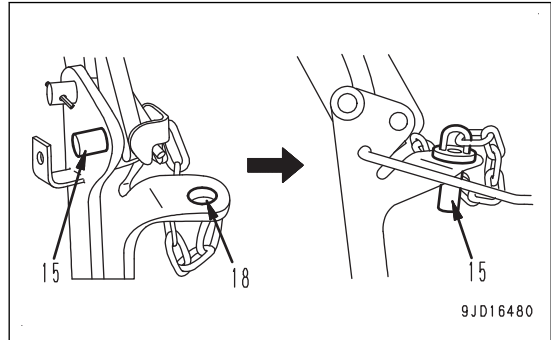

2. While pulling the floor lock release lever (10) to FREE position (F) with your left hand, hold the handle (11) with your right hand and push it down slowly to the direction of arrow (approximately 45 °) to release the first lock.
3. Hold the handle (11) with your right hand and lower the floor slowly to the direction of arrow (approximately 45 °).

NOTICE

Check that there is no pinched or damaged wiring harness and piping.

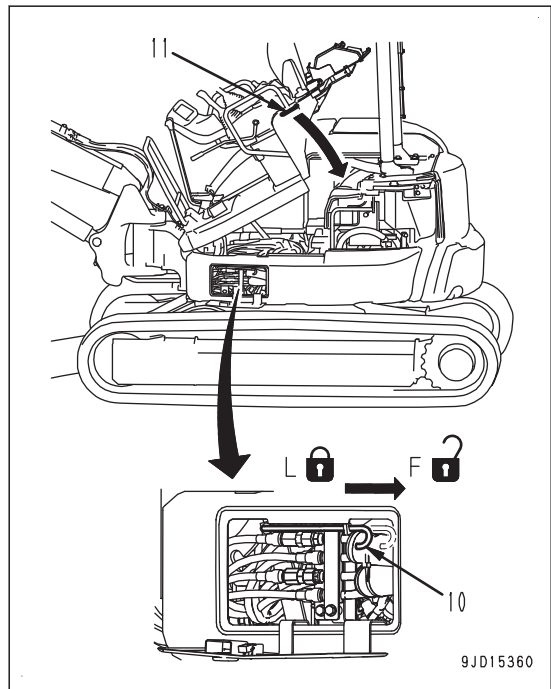

4. Close the inspection window (9).

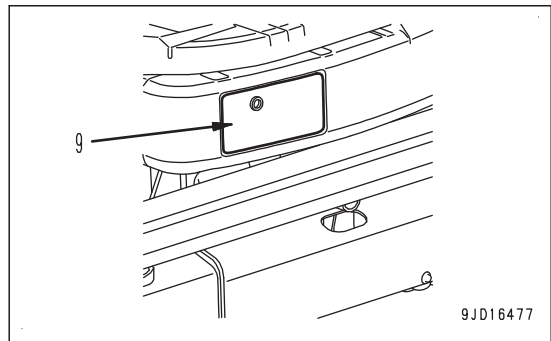

5. Open the engine rear cover (6).
Open the engine rear cover (6) toward you fully and it is secured by the rod (7).

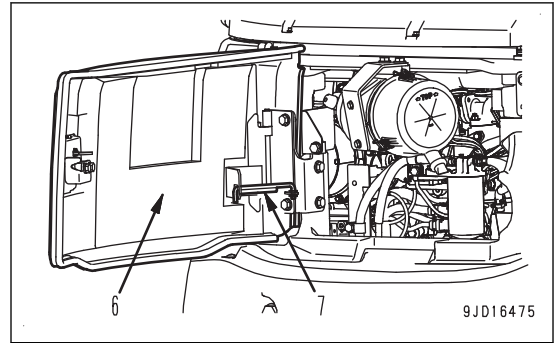

6. Tighten the floor tilt fixing bolt (8) (M14, 1 piece).
Tightening torque:
156.8 to 196.0 Nm {16.0 to 20.0 kgm, 116 to 145 lbf}

REMARK

If any of the floor tilt fixing bolts is damaged, replace it with a Komatsu genuine part of the same size.

7. Close the engine rear cover (6).

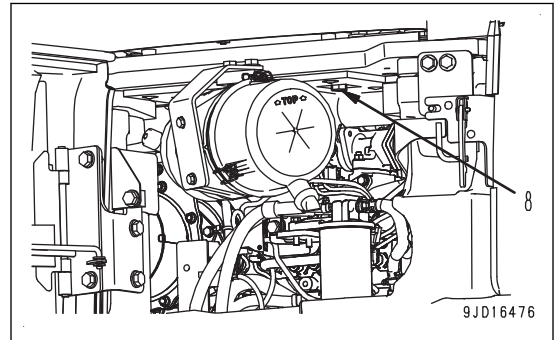

8. Tighten the floor tilt fixing bolts (5) (M14, 2 pieces).
Tightening torque:
156.8 to 196.0 Nm {16.0 to 20.0 kgm, 116 to 145 lbf}

REMARK

If any of the floor tilt fixing bolts is damaged, replace it with a Komatsu genuine part of the same size.

9. Install the cover (4) with the cover fixing bolts (3) (M8, 4 pieces).

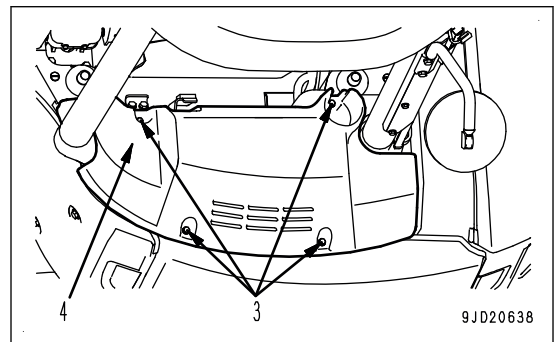
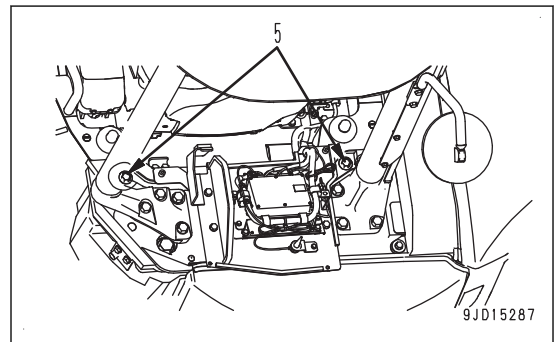

10. Install the triangle cover (2) with the triangle cover fixing bolts (1) (M10, 3 pieces).

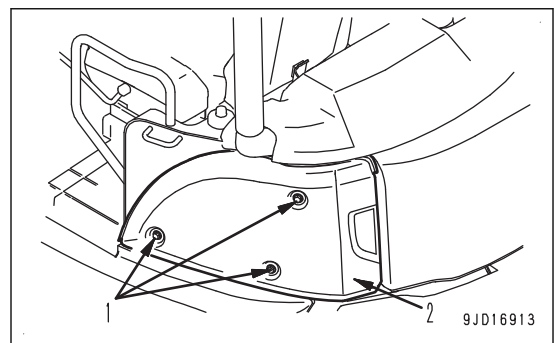

Floor closing work is completed.

METHOD FOR CLOSING FLOOR UNIT: CAB SPEC

1. Remove the lock pin (13) of the second lock, and insert it into holder hole (16).

If it is hard to remove the lock pin (13), hold the handle (9) and while pulling it up, remove the lock pin (13).

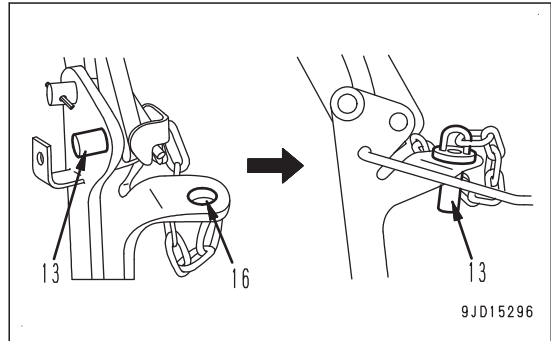

2. While pulling the floor lock release lever (8) to FREE position (F) with your left hand, hold the handle (9) with your right hand and push it down slowly to the direction of arrow (approximately 45 °) to release the first lock.
3. Hold the handle (9) with your right hand and lower the floor slowly to the direction of arrow (approximately 45 °).

NOTICE

Check that there is no pinched or damaged wiring harness and piping.

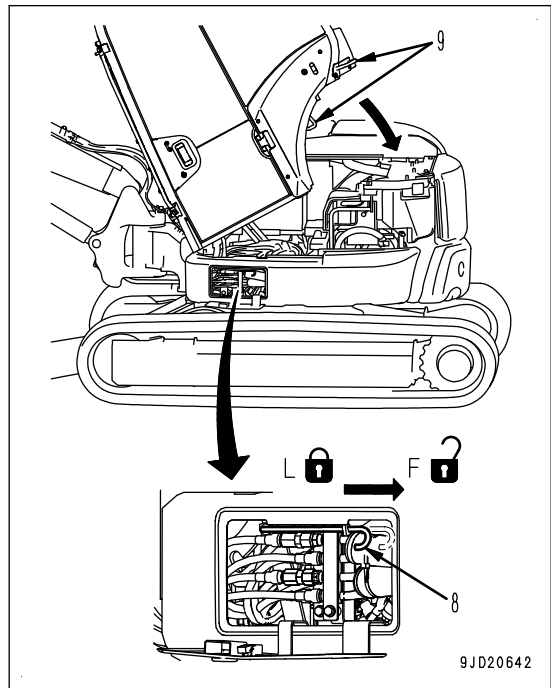

4. Close the inspection window (7).

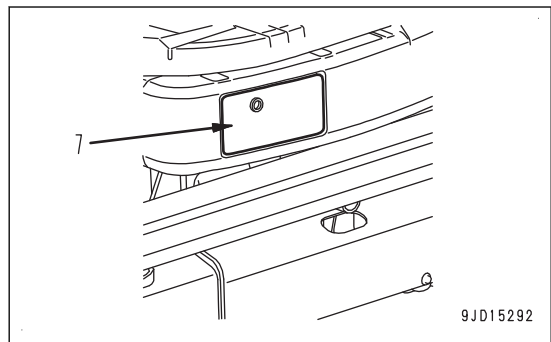

5. Open the engine rear cover (4).
Open the engine rear cover (4) toward you fully and it is secured by the rod (5).

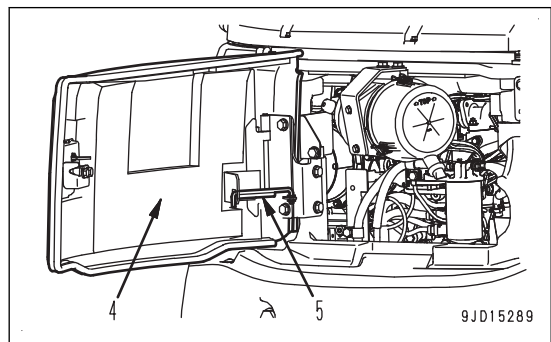

6. Tighten the floor tilt fixing bolts (6) (M14, 4 pieces).

Tightening torque:

156.8 to 196.0 Nm {16.0 to 20.0 kgm, 116 to 145 lbft}

REMARK

- If any of the floor tilt fixing bolts is damaged, replace it with a Komatsu genuine part of the same size.
- When the air cleaner has been moved downward, restore it to the original position, and install the air cleaner mounting bracket with bolts (A).

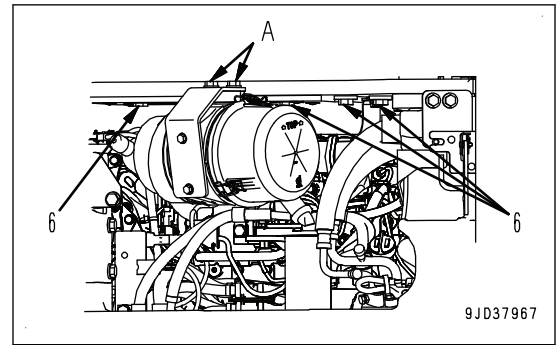

7. Close the engine rear cover (4).

8. Tighten the floor tilt fixing bolts (3) (M14, 2 pieces).

Tightening torque:

156.8 to 196.0 Nm {16.0 to 20.0 kgm, 116 to 145 lbft}

REMARK

If any of the floor tilt fixing bolts is damaged, replace it with a Komatsu genuine part of the same size.

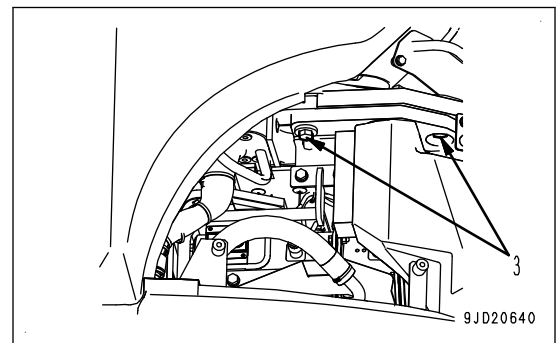

9. Install the triangle cover (2) with the triangle cover fixing bolts (1) (M10, 3 pieces).

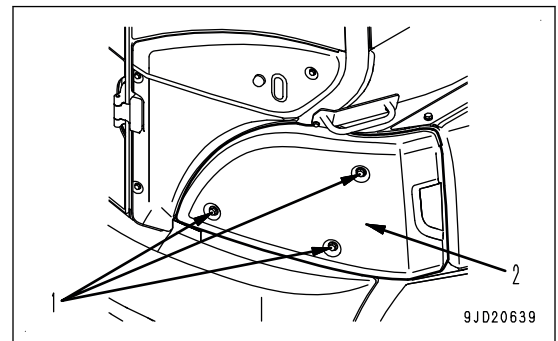

Floor closing work is completed.

POWER SUPPLY OUTLET

12 V power supply

NOTICE

**After using the receptacle for external electric equipment, always close the cap.
If the cap is left open, rainwater, etc. enters and may cause short circuit.**

Capacity of this power supply is 120 W (12 V x 10 A).

Use the power outlet as a power supply for the lighting equipment, etc.

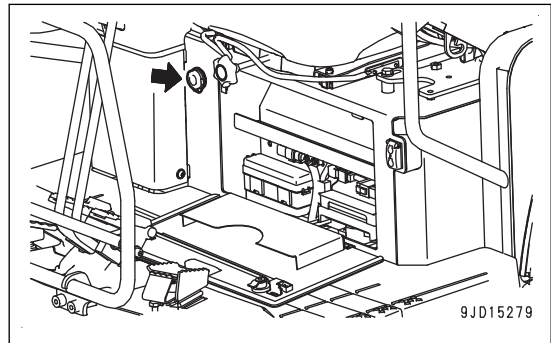

FUSE

NOTICE

When replacing the fuse, make sure to turn the starting switch to OFF position, and then disconnect the negative (-) terminal of the battery.

For the machines equipped with a battery disconnect switch, set the battery disconnect switch to OFF position.

- The fuse holder is provided inside the cover under the operator's seat.
- The fuse protects the electrical component and wiring from burning out.
- If the fuse becomes corroded, or looks white powdery, or the fuse is loose in the fuse holder, replace the fuse.
- Replace the fuse with the one of the same capacity.

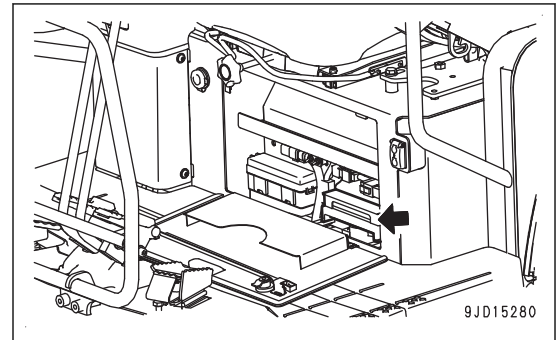

Fuse capacities and circuit names

Machine with canopy specification

No.	Capacity	Name of circuit
(1)	5 A	Working lamp relay, additional working lamp relay, and pump secondary drive switch
(2)	10 A	Solenoid valve
(3)	5 A	PPC hydraulic lock solenoid
(4)	10 A	Spare
(5)	10 A	Travel alarm, fuel pump, and horn
(6)	10 A	Spare
(7)	10 A	Spare
(8)	10 A	Heater
(9)	10 A	External power supply
(10)	5 A	ACC signal
(11)	10 A	Working lamp, Travel lamp
(12)	5 A	System operating lamp (if equipped)
(13)	10 A	Machine monitor and controller
(14)	20 A	Engine controller
(15)	20 A	EGR valve

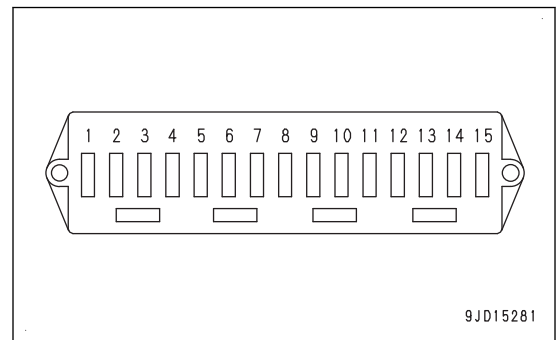

Machine with cab specification

No.	Capacity	Name of circuit
(1)	5 A	Working lamp relay, additional working lamp relay, and pump secondary drive switch
(2)	10 A	Solenoid valve
(3)	5 A	PPC hydraulic lock solenoid
(4)	10 A	Room lamp, radio, and windshield wiper
(5)	10 A	Travel alarm, fuel pump, and horn
(6)	10 A	Spare
(7)	10 A	Spare
(8)	20 A	Air conditioner and heater
(9)	10 A	External power supply
(10)	5 A	ACC signal
(11)	30 A	Working lamp, Travel lamp and additional working lamp
(12)	10 A	Radio and system operating lamp (if equipped)
(13)	10 A	Machine monitor and controller
(14)	20 A	Engine controller
(15)	20 A	EGR valve

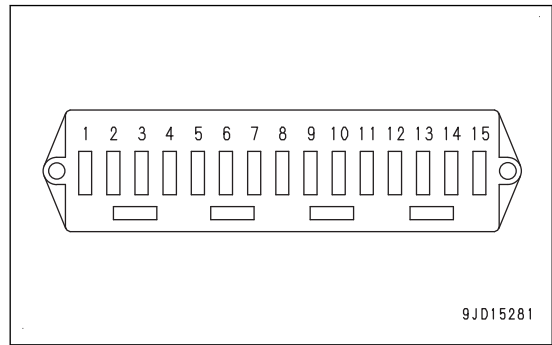

Fuses (16) for replacement are provided in the fuse holder. After using fuses (16) for replacement, replenish them immediately.

Fuses (16) for replacement are 5 A, 10 A, 20 A, and 30 A each 1 piece.

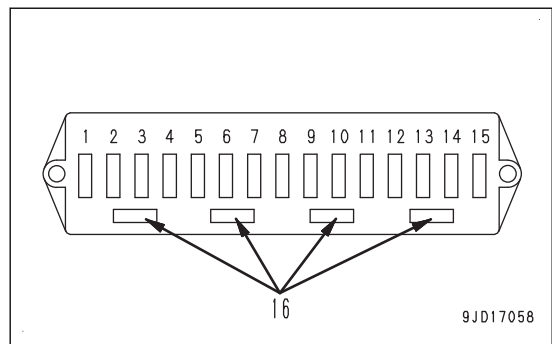

FUSIBLE LINK

NOTICE

When replacing the fuse, make sure to turn the starting switch to OFF position, and then disconnect the negative (-) terminal of the battery.

For the machines equipped with a battery disconnect switch, set the battery disconnect switch to OFF position.

If the following phenomena occur, fusible links are suspected of disconnection. Open the dirt cover, check and replace it if necessary.

- If the starting motor does not operate even when the starting switch is turned to START position, the fusible link (1), (2), or (4) may be broken.
- Fusible link (3) is suspected of disconnection if it is hard to start the engine even after the engine preheating has been performed when temperature is low.

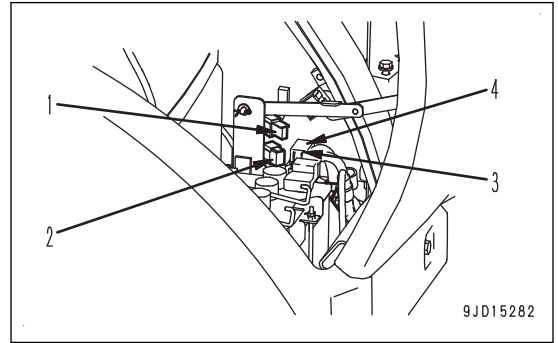

REMARK

A fusible link is the large-sized fuse wiring installed in the high current flowing part of the circuit.

It protects electrical parts and wiring from burning out due to abnormal current, in the same way as an ordinary fuse.

No.	Capacity	Name of circuit	Connector No.
(1)	45 A	Continuous power supply	M09
(2)	65 A	Standard power supply	M05
(3)	80 A	Preheat	TM14
(4)	60 A	Starting motor	TM15

TOOL BOX

Store the tools and warning tags in it.

It is located inside the cover under the operator's seat.

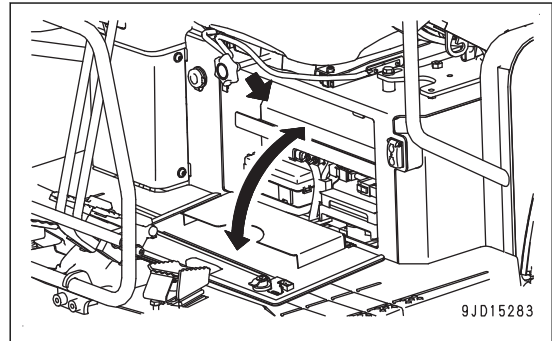

GREASE PUMP HOLDER

It is located inside the dirt cover on the front right of the machine.

Keep the grease pump hooked on this holder while it is not used.

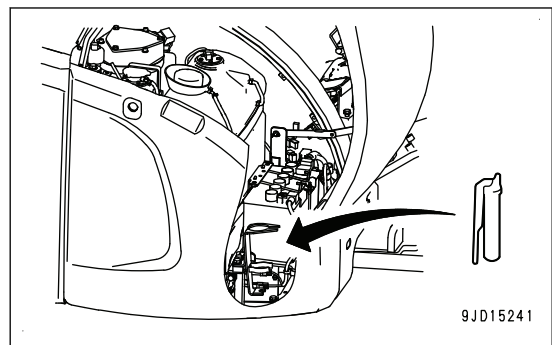

HANDLE Komatsu Diesel Particulate Filter (KDPF)

⚠ CAUTION

- Exhaust gas temperature may increase during the aftertreatment devices regeneration and the high temperature may last after the completion of regeneration. Avoid getting near the exhaust pipe outlet and around the aftertreatment devices to prevent being burnt. Keep combustible materials away from the exhaust pipe outlet and around the aftertreatment devices to prevent a fire.
- When there are thatched houses, dry leaves or pieces of paper near the job site, set the system to the regeneration disable to prevent fire hazards due to highly heated exhaust gas during the aftertreatment devices regeneration.
- Do not leave the operator's seat during the regeneration of the aftertreatment devices.

KDPF is a device to capture soot in the exhaust gas to purify the exhaust gas.

If soot is accumulated to a certain level in the filter, a purification process to burn the soot is performed automatically to keep the filtering performance of KDPF high.

This purification process is called "Regeneration".

If operations which lower the purification function of KDPF continues for long hours, the regeneration is performed to protect the KDPF system, regardless of the quantity of the accumulated soot.

During the regeneration of KDPF, aftertreatment devices regeneration pilot lamp (1) stays lit on the machine monitor.

REMARK

Even if aftertreatment devices regeneration pilot lamp (1) lights up, the machine does not need to be stopped and the work can be continued, unless the caution lamp is displayed at the center of the machine monitor.

The KDPF regeneration is performed automatically. However, the accumulated soot may not be burnt sufficiently and the filtering function may not be improved under certain operating conditions.

In that case, the KDPF soot accumulation caution lamp (2) lights up. If this lamp lights up, stop the machine in a safe place and perform the manual stationary regeneration.

KDPF soot accumulation caution lamp (2) requires the manual stationary regeneration in 2 levels corresponding to the degree of urgency.

NOTICE

- If the work is continued with red KDPF soot accumulation caution lamp (2) displayed, KDPF or the engine can have trouble. If KDPF soot accumulation caution lamp (2) is displayed, be sure to perform the manual stationary regeneration.
- If the engine is stopped during the aftertreatment devices regeneration, the components may be damaged. While the aftertreatment devices regeneration is being performed, stop the aftertreatment devices regeneration first, run the engine at low idle for approximately 5 minutes, and then stop the engine.

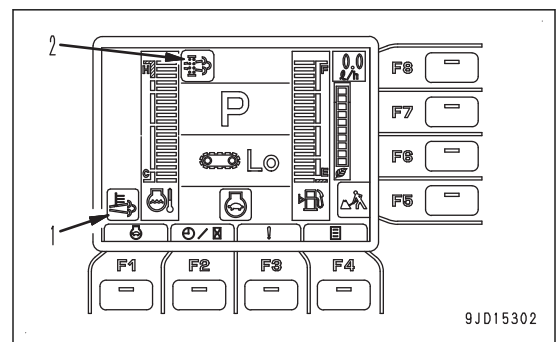
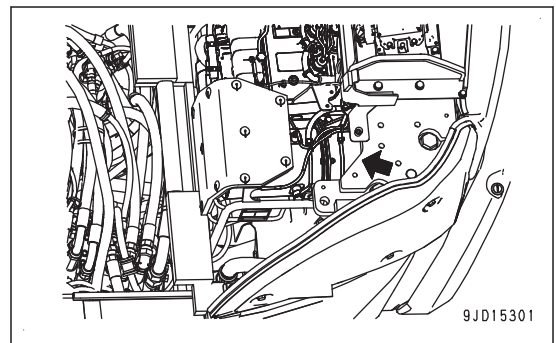

REMARK

- The soot accumulation level (4) can be checked on “After-treatment Devices Regeneration” screen. Press the function switch “F4” on the standard screen to display the “After-treatment Devices Regeneration” screen of the user menu.
- The soot accumulation quantity may decrease even if the regeneration is not performed, depending on the operating condition. It is because the soot in the filter of KDPF can be burnt by the high-performance catalyst and high-temperature exhaust heat.
- Even when the soot accumulation level is low, the automatic regeneration may be performed and the manual stationary regeneration may be requested to protect the system. In particular, if engine is kept running with no load, the regeneration frequency may increase, but this is not a failure.
- Even just after the regeneration is completed, the soot accumulation level may not be "0". This is caused by the accumulated noncombustible material in the exhaust gas and is not a failure.
- Since noncombustible matter which cannot be burnt by the regeneration is accumulated in the filter of KDPF, the filter needs to be cleaned or replaced at regular intervals. Ask your Komatsu distributor for cleaning the inside of KDPF.
- The engine speed or engine sound may change during or after the regeneration. This is caused by the control for better regeneration and this is not a failure.
- The smell of the exhaust gas is different from that of the conventional diesel engine because of the exhaust gas filtering function.
- White smoke may be discharged for a short time just after the engine is started or during the regeneration in the cold season, but this is not a failure.
- Komatsu recommends using Komatsu genuine engine oil for KDPF.
If engine oil other than Komatsu genuine oil for KDPF is used, it may shorten cleaning interval of KDPF filters, adversely affect the engine such as deteriorated oil may reduce lubricating function, and it may cause failure.
The regeneration interval may be shortened and the fuel consumption may increase.
- If the mixing ratio of the bio-fuel in the diesel fuel is high, the regeneration of KDPF may become more frequent.

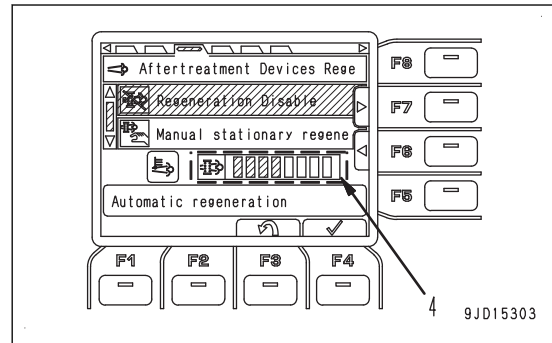

When the degree of emergency is low

- If KDPF soot accumulation caution lamp (2) lights up in yellow (action level (3): "L01"), screen (A) is displayed first.
- The action level goes out 2 seconds later, and the screen changes back to standard screen (B).
- If the lock lever is set to LOCK position or all the work equipment control levers are set in NEUTRAL, the screen changes to "Aftertreatment Devices Regeneration" screen (C) after 3 seconds only the first time. If the manual stationary regeneration is not performed, the screen returns to standard screen (B) after 30 seconds. Then, if the accumulated soot does not decrease, "After-treatment Devices Regeneration" (C) is displayed for 30 seconds every 2 hours.
- If the KDPF soot accumulation caution lamp (2) lights up in yellow, stop the machine in a safe place after finishing the work and perform the manual stationary regeneration.

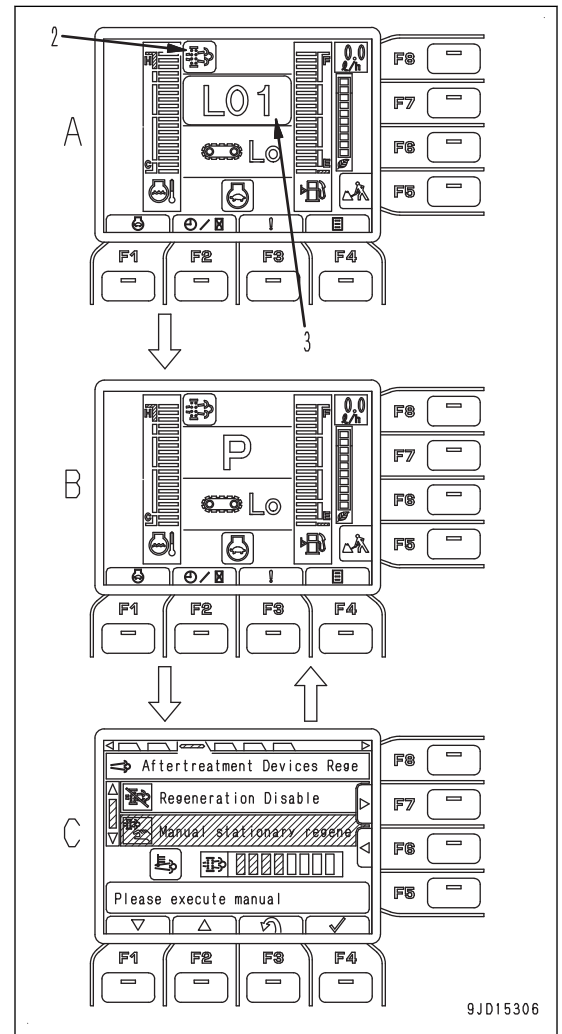

When the degree of urgency is high

- If KDPF soot accumulation caution lamp (2) lights up in red (action level (3): "L03"), screen (D) is displayed first.
- The action level goes out 2 seconds later, and the screen changes back to the warning screen (E).
- If the lock lever is set to LOCK position or all the work equipment control levers are set in NEUTRAL, the screen changes to "Aftertreatment Devices Regeneration" screen (C) after 3 seconds. Then, "Aftertreatment Devices Regeneration" screen (C) and the warning screen (E) are automatically displayed alternately according to the lever operation, until the manual stationary regeneration is performed.
- If the KDPF soot accumulation caution lamp (2) lights up in red, immediately stop the machine in a safe place and perform the manual stationary regeneration.

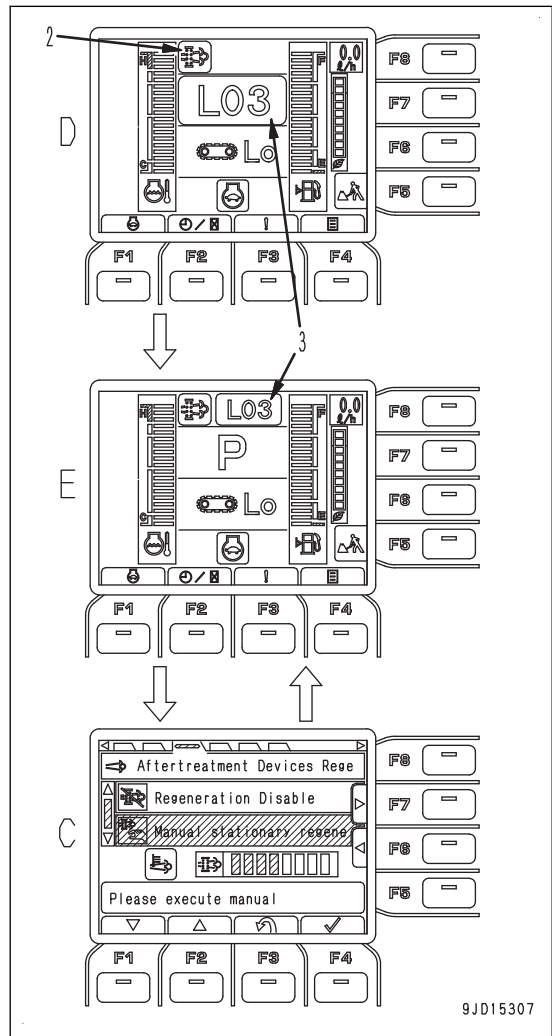

REMARK

If KDPF soot accumulation caution lamp (2) lights up in red, the maximum engine output power and maximum engine speed are limited to protect the engine and KDPF system.

NOTICE

If the work is continued without performing the manual stationary regeneration, and the quantity of soot exceeds the allowable limit, action level "L04" lights up.
If action level display "L04" lights up, ask your Komatsu distributor for repair.
The maximum engine output power and maximum engine speed are limited to protect the engine and KDPF system.

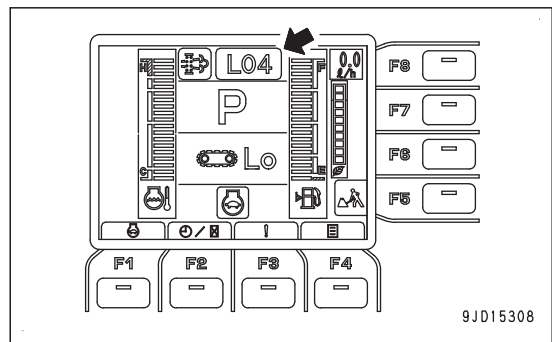

PROCEDURE FOR MANUAL STATIONARY REGENERATION

⚠ CAUTION

Exhaust gas temperature may increase during the aftertreatment devices regeneration and the high temperature may last after the completion of regeneration. Avoid getting near the exhaust pipe outlet and around the aftertreatment devices to prevent being burnt. Keep combustible materials away from the exhaust pipe outlet and around the aftertreatment devices to prevent a fire.

The manual stationary regeneration can be performed while KDPF soot accumulation caution lamp (2) is lit and the warm-up operation has completed.

1. Move the machine to a safe place and stop it while the engine is running.
2. Check that there is no person or combustible matter around the machine (particularly in the direction of the exhaust gas flow).
3. Set the lock lever to LOCK position (L).
Be sure to operate the lock lever by the operating portion on the top.

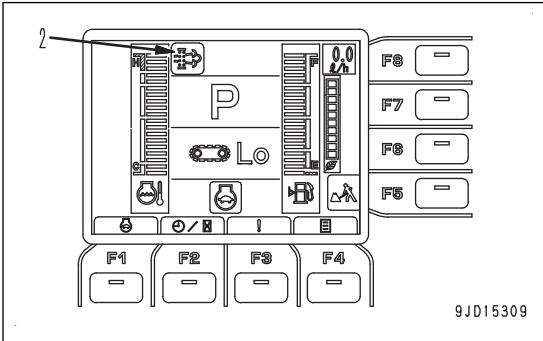

9JD15309

4. Turn the fuel control dial to Low idle (MIN) position (a).

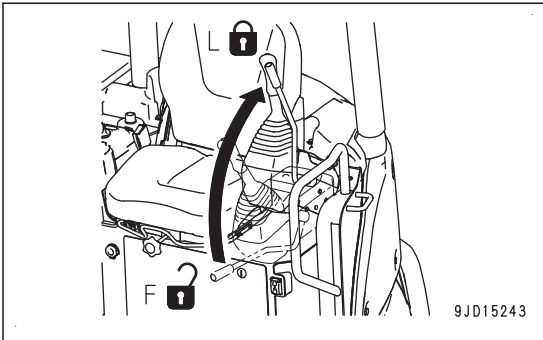

9JD15243

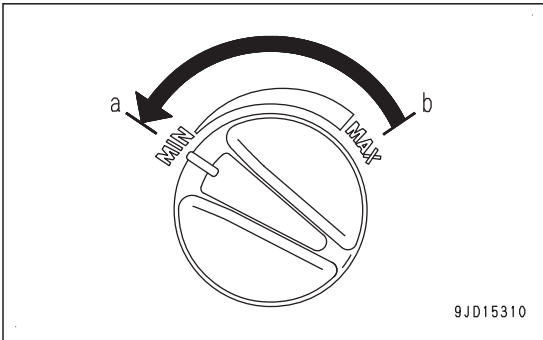

9JD15310

5. On the standard screen, press the function switch "F4" to display "Aftertreatment Devices Regeneration" screen.

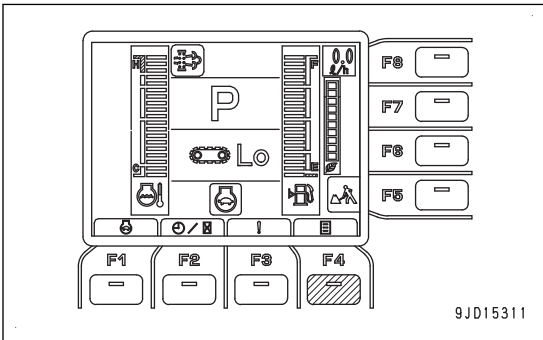

9JD15311

- 6. Select "Manual Stationary Regeneration", check again that there is no person or combustible material around the machine, and then press the function switch "F4".

If the machine needs to be moved again to secure safety, move it to a safe place and repeat the procedure from step 1.

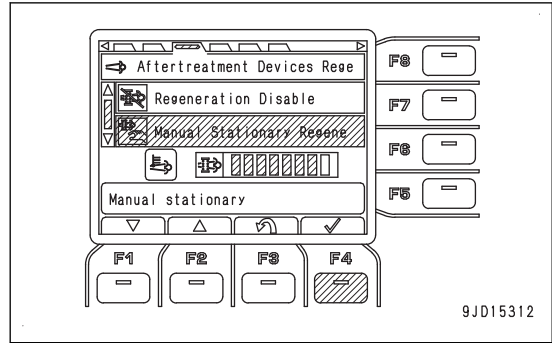

REMARK

- If you start the manual stationary regeneration, the engine speed increases gradually to the full speed. It may take approximately 1 minute to start increasing the engine speed.

- After the function switch "F4" is pressed, the screen shown in the figure may be displayed.

This indicates that the procedure from step 1 to 4 is not performed correctly or there is trouble other than KDPF soot accumulation abnormality.

Check that the engine is running normally, the lock lever is in LOCK position, and the fuel control dial is in Low idle (MIN) position, and then repeat the procedure from step 6.

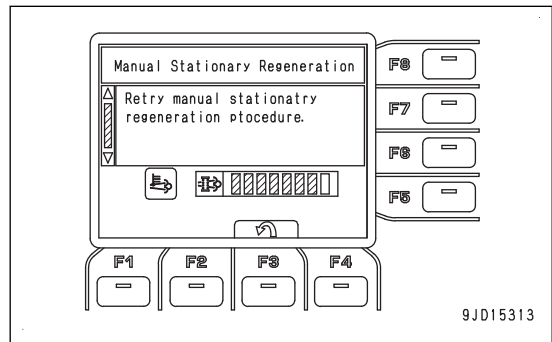

- The explanation sentence of the manual stationary regeneration is displayed on the machine monitor in 4 separate paragraphs.

Press the function switch "F4", and you can operate the starting of regeneration.

Press the function switch "F3", and the screen returns to the standard screen.

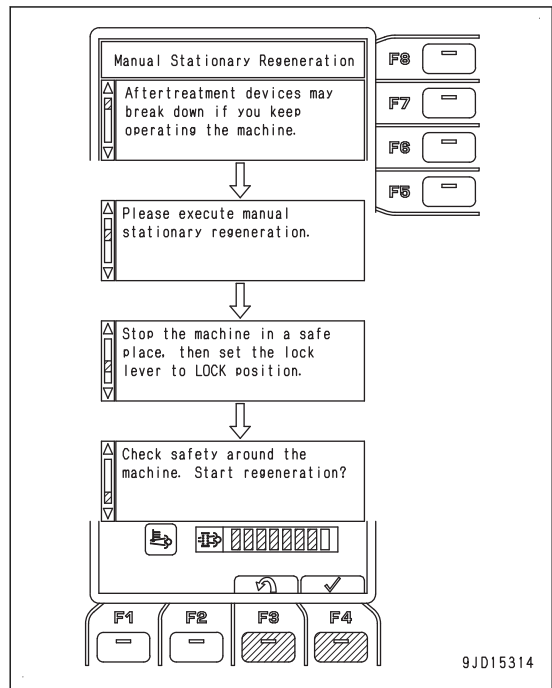

- If the monitor switch is not operated for 30 seconds, the explanation of the manual stationary regeneration is displayed for 30 seconds, and then the screen returns to the standard screen.

To display the explanation of the manual stationary regeneration again, press the function switch “F4” on the standard screen to display “Aftertreatment Devices Regeneration” screen.

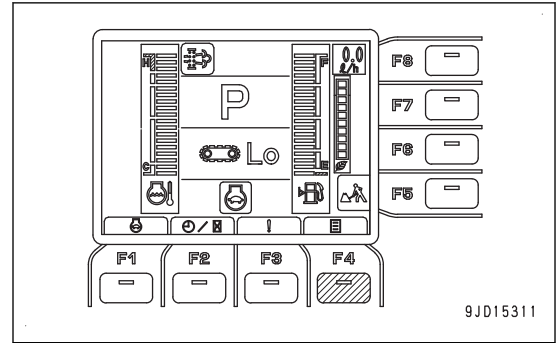

- When the manual stationary regeneration cannot be performed even if the procedure is repeated from step 1, return to the standard screen and check that the engine coolant temperature gauge indicates correct temperature.

If it indicates low temperature (lights up in white), perform the warm-up operation and repeat the procedure from step 1.

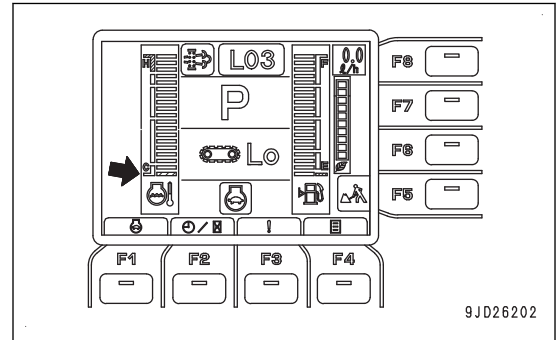

- If the manual stationary regeneration still cannot be performed, return to the standard screen, press the function switch “F3” to check the contents of other occurred failures, stop the work and perform inspection and maintenance.

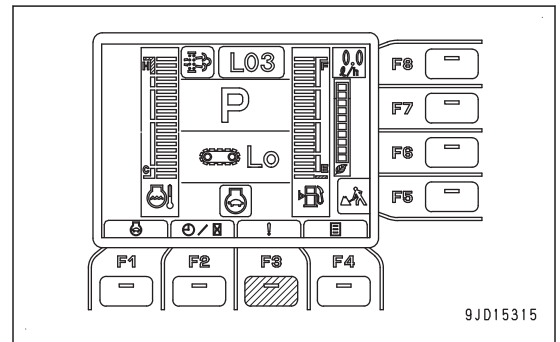

7. The screen shown in the figure is displayed during the manual stationary regeneration.

It may take 30 minutes or longer to complete the manual stationary regeneration. Do not touch any switch on the screen nor operate the fuel control dial until the regeneration is completed and the screen returns to the standard screen.

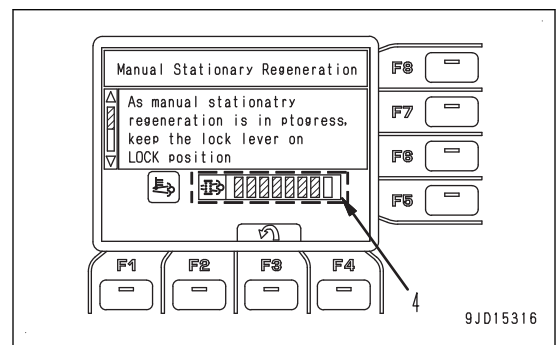

REMARK

- The progress of the manual stationary regeneration performed when soot is accumulated can be checked by the number of lighting lamps of the soot accumulation level (4).
The manual stationary regeneration starts at the soot accumulation level “4” or higher and finishes when all the level lamps go out.
 - The time required for the manual stationary regeneration depends on the soot deposition level or the ambient temperature when it is started.
 - If the lock lever or the fuel control dial is operated during the manual stationary regeneration, the regeneration is stopped automatically.
Return the lock lever to LOCK position (L) and return the fuel control dial to Low idle (MIN) position, then repeat the procedure from step 6.
 - If the machine needs to be moved during the manual stationary regeneration, stop the regeneration temporarily and move the machine by referring to the aftertreatment devices regeneration disable and cancel procedures described below.
When restarting the manual stationary regeneration, secure the safety of the machine and around it, then cancel the regeneration disable.
8. When the manual stationary regeneration is completed, the engine speed gradually decreases to low speed, and the screen automatically returns to the standard screen.

PROCEDURE FOR AFTERTREATMENT DEVICES REGENERATION DISABLE SETTING

If there is combustible material around the machine and the active regeneration that increases the exhaust temperature must not be performed, the automatic active aftertreatment devices regeneration can be disabled.

The regeneration can be disabled while aftertreatment devices are in regeneration.

NOTICE

Even if the regeneration is disabled, KDPF soot accumulation caution lamp (2) lights up if soot is accumulated and the manual stationary regeneration is required. If KDPF soot accumulation caution lamp lights up, move the machine to a safe place and perform manual stationary regeneration.

If the operation is continued without performing the manual stationary regeneration, it may cause the failure of KDPF or the engine.

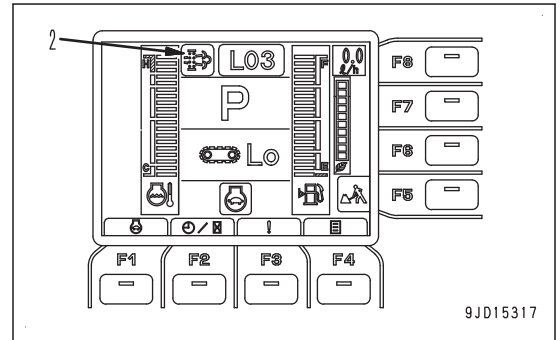

While the regeneration is not being performed: Setting for the regeneration disable

- When the aftertreatment devices regeneration pilot lamp is not displayed on the standard screen
On the standard screen, press function switch "F4" to display the user menu.

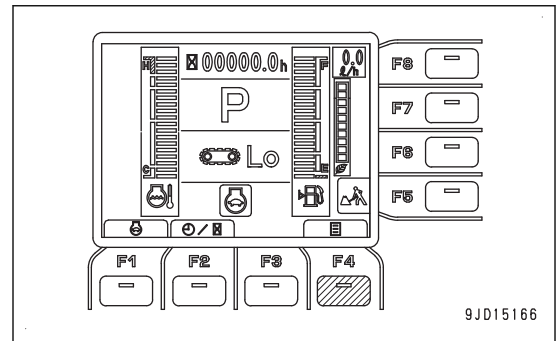

- On the user menu, press function switches "F6" and "F7" to display "Aftertreatment Devices Regeneration" screen.

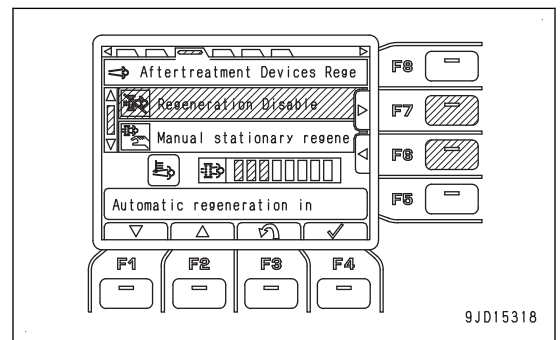

- Select "Regeneration Disable" on "Aftertreatment Devices Regeneration" screen, and then press function switch "F4". "Regeneration Disable" confirmation screen is displayed.

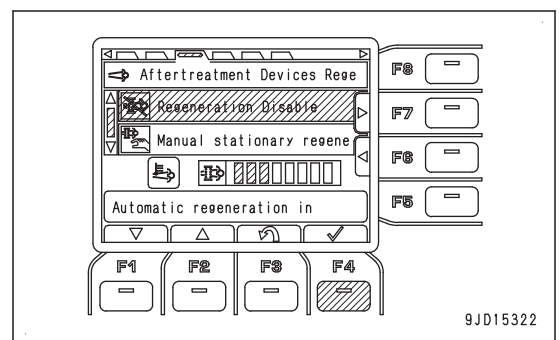

- On "Regeneration Disable" confirmation screen, press function switch "F4".

REMARK

If you press function switch "F3", regeneration is not disabled and the screen returns to "Aftertreatment Devices Regeneration" screen.

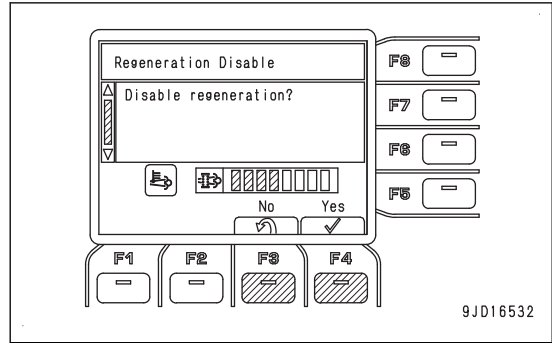

- The screen returns to "Aftertreatment Devices Regeneration" screen, and regeneration is disabled.

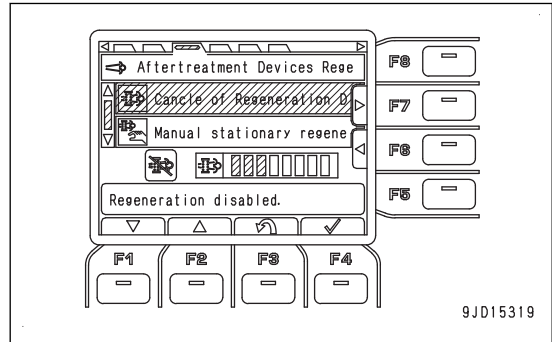

REMARK

- When the regeneration is disabled, aftertreatment devices regeneration disable pilot lamp (5) is displayed with hatch on the standard screen.
- The setting of regeneration disable is canceled by turning starting switch to OFF position. When the automatic regeneration needs to be kept disabled, perform the procedure from step 1 to 5 each time you start the engine.

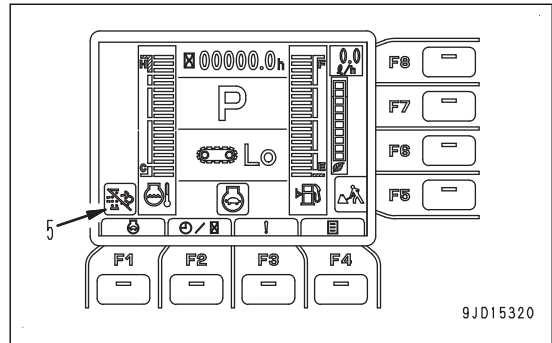

While regeneration is being performed: Regeneration is disabled

- When aftertreatment devices regeneration pilot lamp (1) is displayed on the standard screen

On the standard screen, if you press function switch "F4", "Aftertreatment Devices Regeneration" screen is displayed.

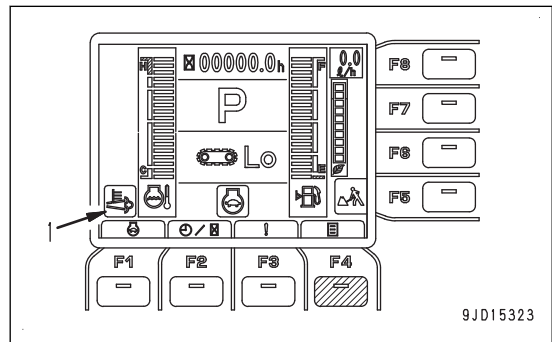

- Select "Regeneration Disable" on "Aftertreatment Devices Regeneration" screen, and then press function switch "F4". "Regeneration Disable" confirmation screen is displayed.

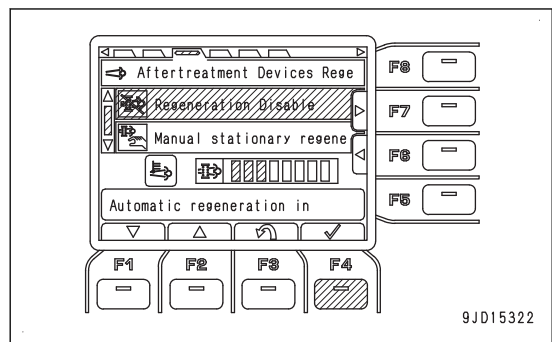

- On "Regeneration Disable" confirmation screen, press function switch "F4".

REMARK

If you press function switch "F3", regeneration is not disabled and the screen returns to "Aftertreatment Devices Regeneration" screen.

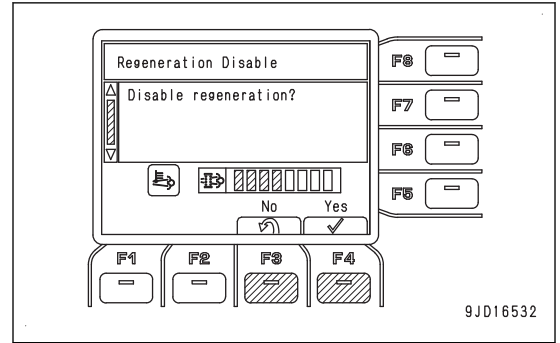

- The screen returns to "Aftertreatment Devices Regeneration" screen, and regeneration is disabled.

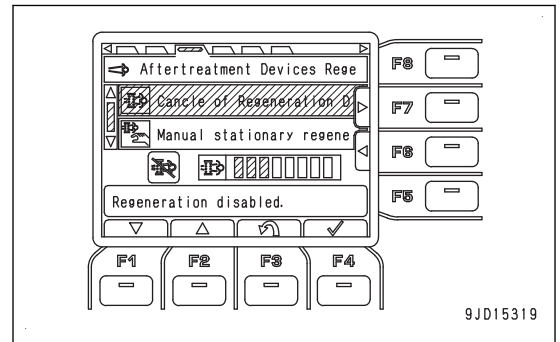

REMARK

When the regeneration is disabled, aftertreatment devices regeneration disable pilot lamp (5) is displayed with hatch on the standard screen.

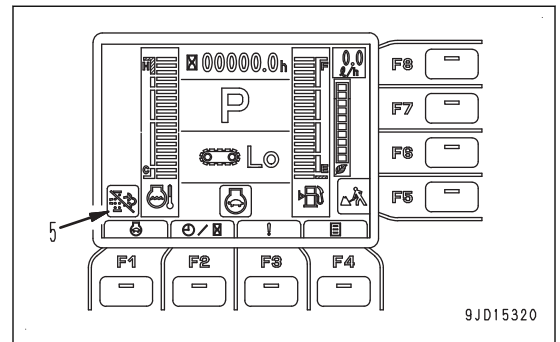

PROCEDURE FOR CANCEL OF AFTERTREATMENT DEVICES REGENERATION DISABLE SETTING

⚠ CAUTION

When canceling the regeneration disable, move the machine to a safe place and check that there is no person or combustibile matter around the machine, and start the cancel operation.

1. On the standard screen, if you press function switch "F4", "Aftertreatment Devices Regeneration" screen is displayed.

(If the screen is not displayed, operate function switches "F6" and "F7" to display "Aftertreatment Devices Regeneration" screen.)

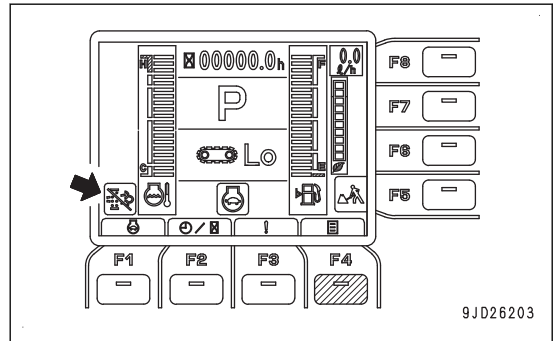

2. On "Aftertreatment Devices Regeneration" screen, select "Cancel of Regeneration Disable", and then press function switch "F4".

"Cancel of Regeneration Disable" confirmation screen is displayed.

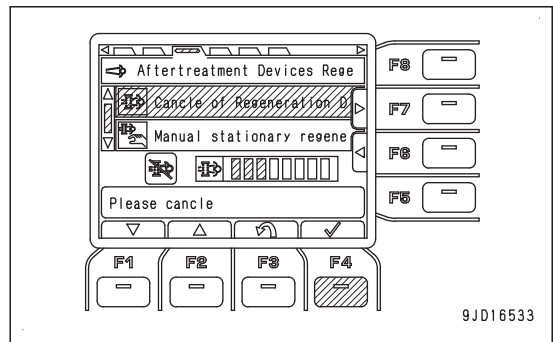

3. On "Regeneration Disable" confirmation screen, press function switch "F4".

The screen returns to "Aftertreatment Devices Regeneration" screen, and the regeneration disable is canceled.

REMARK

If you press function switch "F3", regeneration disable is not canceled and screen returns to "Aftertreatment Devices Regeneration" screen.

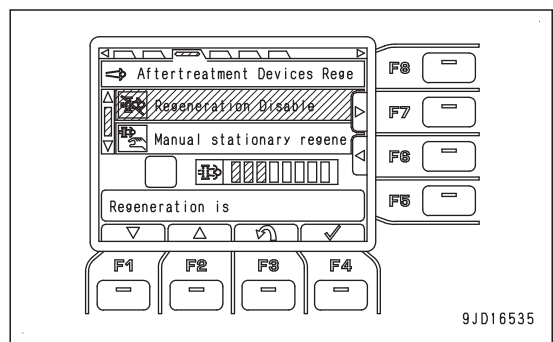
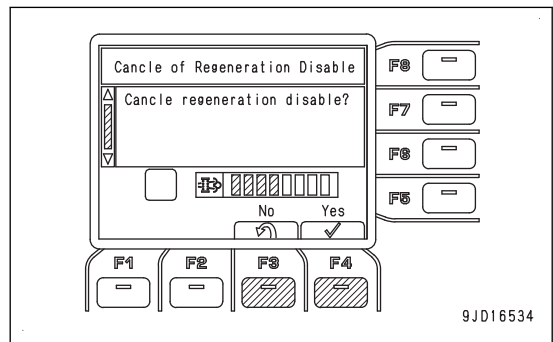

If soot accumulation level (4) is lit 3 or more, the regeneration is started automatically.

REMARK

- When canceling the regeneration disable, set the lock lever to LOCK position and set the fuel control dial to Low idle (MIN) position, then cancel the regeneration disable.
- The regeneration disable setting is also canceled by turning the starting switch to OFF position to stop the engine.

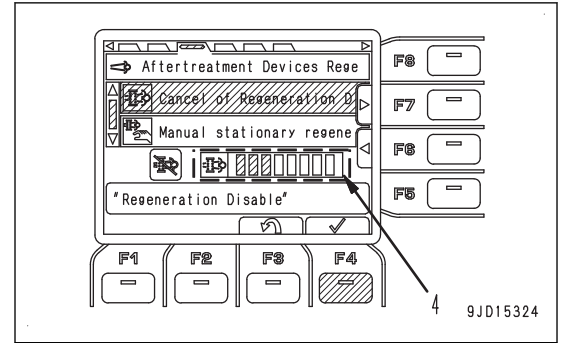

KOMTRAX

WARNING

- Never disassemble, repair, modify, or move the wireless communication terminal, antenna, or cables. This may cause failure or fire on the wireless equipment or the machine itself.
- Near the blasting jobsite, there may be a danger of unexpected explosion due to use of the wireless equipment and resulting serious personal injury or death.
If you have to operate the machine within 12 m {within 39 ft 4 in} from the remote-controlled blasting device, the power supply cable of the wireless communication device must be disconnected in advance.

KOMTRAX is a vehicle management system that remotely manages the machines equipped with the KOMTRAX device by using satellite communication or portable radio communication.

The GPS (Global Positioning System), receiver, and communication system are equipped in the vehicle management system.

The machine information such as the machine maintenance, maintenance management, operating situation management, and machine location management is gathered from the inside network of the machine. It can be useful for you to perform the machine management by yourself. Your Komatsu distributor uses the above machine information for supply of service to the customers, improvement of our products and service, etc.

The type of information which is sent from the machine may vary depending on the machine. For the radio station establishment of KOMTRAX, consult your Komatsu distributor.

POWER SUPPLY FOR KOMTRAX

- Even when the key in the starting switch is at OFF position, a small amount of electric power is consumed by the KOMTRAX system.
It is recommended to run the engine periodically to charge the battery.
- When using the battery disconnect switch (if equipped), turn the starting switch to OFF position, and after checking that the system operating lamp is not lit, set the battery disconnect switch key to OFF position and pull it out.
When the battery disconnect switch (if equipped) is turned to OFF position, it is possible to prevent the power consumption of the battery, but the functions of KOMTRAX will stop at the same time.
- If the power supply cable of KOMTRAX system device has to be disconnected, contact your Komatsu distributor.

MACHINE OPERATIONS AND CONTROLS

CHECKS AND ADJUSTMENT BEFORE STARTING ENGINE

METHOD FOR WALK-AROUND CHECK

Before starting the engine, walk around the machine and look at the underside of chassis for anything unusual like loose bolts and nuts, leakage of fuel, oil and coolant. Also check the condition of the work equipment and the hydraulic system.

Check also for loose wiring, play, and accumulation of dust in places that get very hot and are exposed to extremely high temperatures.

WARNING

- **The engine rear cover and cooling cover must be fixed with the rod when it is opened during performing check and maintenance.**
- **Accumulation of combustible material or leakage of fuel or oil around the high temperature parts such as the engine muffler or battery may cause fire.**
Check carefully, and if any abnormality is found, repair it or contact your Komatsu distributor.
- **Check that the floor is securely fixed with bolts.**
If it is not securely fixed, it may lead to a serious personal injury or death.

If the machine is inclining, make it level before checking.

Always perform the following inspections and cleaning every day before starting engine for the day's work.

1. Check for damage, wear, play in work equipment, cylinders, linkage, and hoses.
Check for cracks, excessive wear, play in work equipment, cylinders, linkage, and hoses. If any problem is found, repair it.
2. Remove dirt and debris from around the engine, battery, and radiator.
Check for dirt accumulated around the engine and radiator. Also check for combustible material (dry leaves, twigs, etc.) around the battery, engine muffler, or other high temperature engine parts. If any dirt or combustible materials are found, remove them.
3. Check around the engine for coolant and oil leakage.
Check for oil leakage from the engine and coolant leakage from the cooling system. If any problem is found, repair it.
4. Check the fuel line for leakage.
Check for leakage of fuel or damage to the hoses and tubes. If any problem is found, repair it.
5. Check the hydraulic component, hydraulic tank, hoses, and joints for oil leakage.
Check for oil leakage. If any problem is found, repair the place where the oil is leaking.
6. Check the undercarriage (track, sprocket, idler, guard) for damage, wear, loose bolts, or leakage of oil from rollers.
If any problem is found, repair it.
7. Check for abnormality of the handrail and loose bolts.
If any problem is found, repair it. Tighten any loose bolts.
8. Check and clean the machine monitor.
Check the machine monitor for damage. If it has any damage, replace it. When cleaning dust, etc. on the machine monitor surface, use a clean, soft, and dry cloth.

REMARK

When cleaning the stains deposited on the machine monitor surface such as dusts, brush them off using a clean, soft and dry cloth.

For sticky dirt such as oil, remove it with glass cleaner for family use on the market (weakly acid to weakly alkaline, containing no abrasive), and then finish-wipe with a clean, soft, and dry cloth.

9. Check the windows for coming off and breakage.

Check the windows for coming off and breakage. If any of them is broken, repair it. If any window comes off or is broken during operation, do not continue the operation but repair the window immediately.

10. Check and clean the rearview mirrors.

Check the rear view mirror for trouble. If it is damaged, repair it. Clean the surface of the mirror and adjust the angle so that the rear lower area can be seen from the operator's seat.

11. Check the seat belt and mounting hardware.

Check the seat belt and mounting hardware for any abnormality. If any damage is found, ask your Komatsu distributor to replace it with a new one.

12. Check the bucket with hook (if equipped) for damage.

Check the hook, guide, and hook mount for damage. If any problem is found, ask your Komatsu distributor for repair.

METHOD FOR CHECKING BEFORE STARTING

Always check the items in this section before starting the engine each day.

METHOD FOR DRAINING WATER AND SEDIMENT FROM FUEL TANK

NOTICE

Do not use trichloroethylene to clean the inside of tank.

Items to be prepared

Container to catch the fuel

1. Set the machine in the posture shown in the figure.
 - 1) Start the engine.

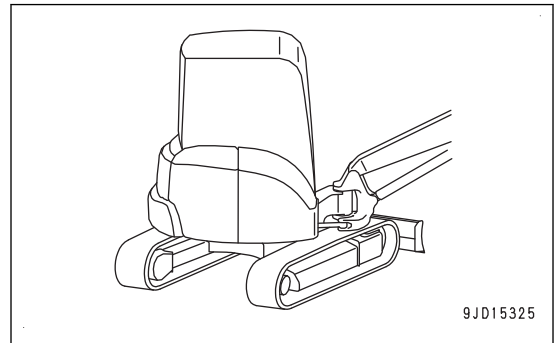

- 2) Set the lock lever to FREE position (F).
Be sure to operate the lock lever by the operating portion on the top.
- 3) Operate the work equipment control lever slowly to right and left to swing the upper structure so that the drain valve comes between the tracks.
- 4) Operate the work equipment control levers, and lower the work equipment to the ground.

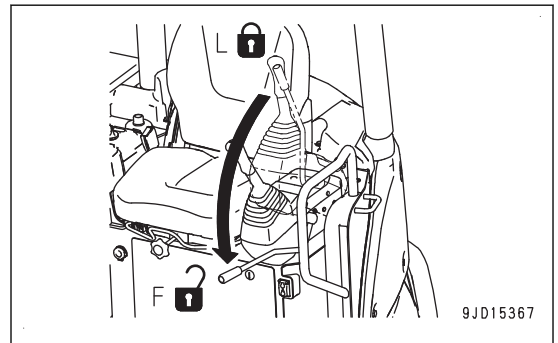

- 5) Set the lock lever to LOCK position (L).
Be sure to operate the lock lever by the operating portion on the top.
- 6) Stop the engine.

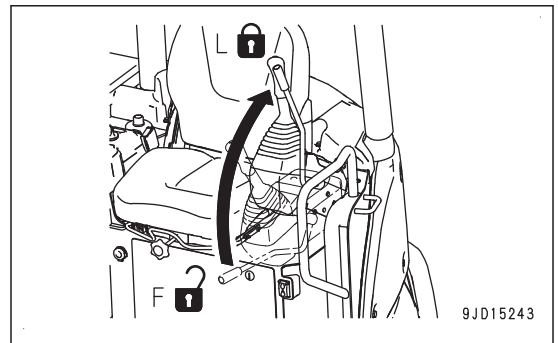

2. Pull the engine rear cover (1) backward to open it.
Open the engine rear cover (1) fully and it is secured by rod (2).

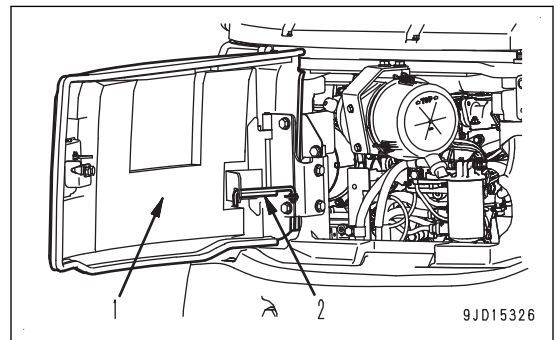

3. Pull the cooling cover (3) backward to open it.

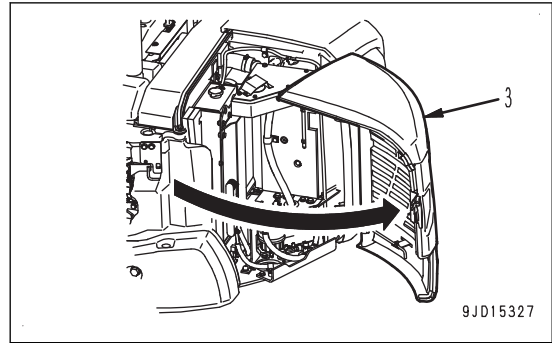

4. Turn the rod (4) to LOCK position (L), and fix the cooling cover (3) with the rod.
5. Place a container under the drain hose to catch the fuel.

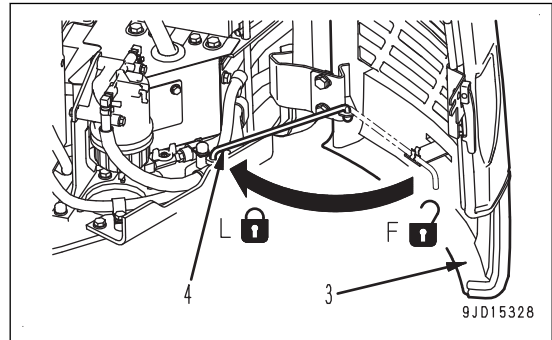

6. Open the drain valve (5) to discharge the sediment and water which is accumulated in the bottom together with the fuel.
Be careful not to get fuel on yourself.
7. When only clean fuel flows out, close the drain valve (5).
8. Turn the rod (4) to FREE position (F), and close the cooling cover (3).
9. Close the engine rear cover (1).

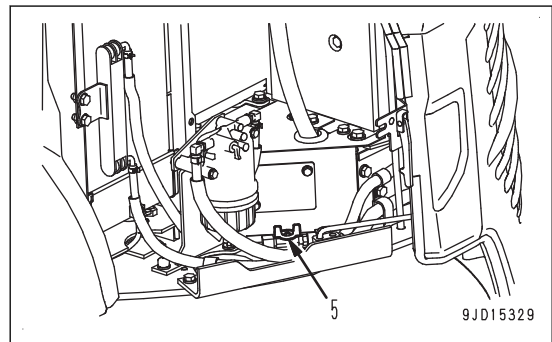

METHOD FOR CHECKING DUST INDICATOR

1. Pull engine rear cover (1) toward you to open it.
Open engine rear cover (1) fully and it is secured by rod (2).

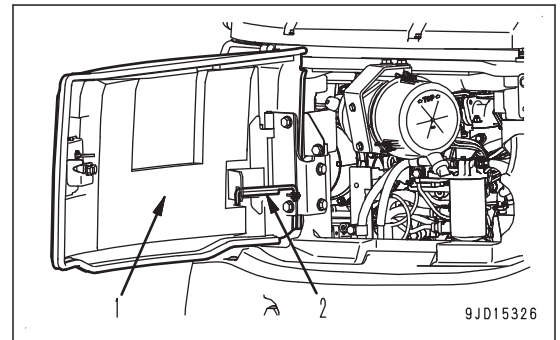

2. Check if the red piston is protruded at the arrow part of dust indicator (3).
If the red piston is protruding, clean or replace the element immediately.
For the cleaning method of the element, see "METHOD FOR CHECKING, CLEANING AND REPLACING AIR CLEANER".

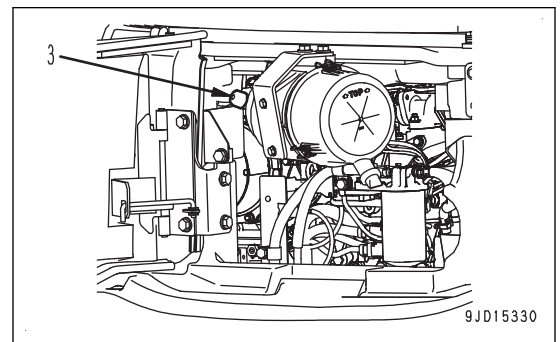

3. After checking, cleaning, and replacing, press the button of dust indicator (3) to return the red piston to its original position.
4. Close engine rear cover (1).

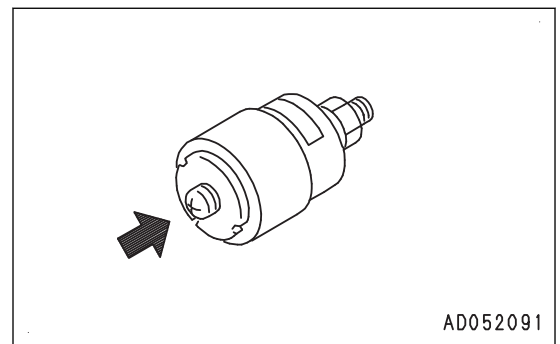

METHOD FOR CHECKING WATER SEPARATOR, DRAINING WATER AND SEDI-MENT

The water separator forms one unit with the fuel prefilter.

1. Pull the engine rear cover (1) backward to open it.
Open the engine rear cover (1) fully and it is secured by rod (2).

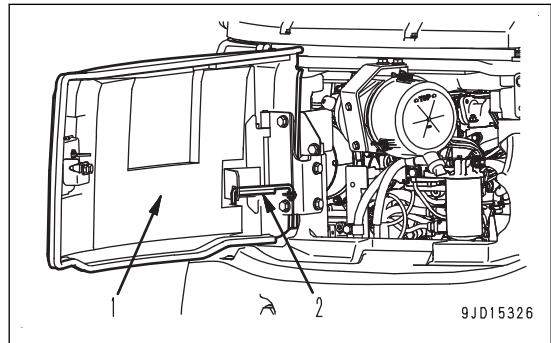

2. Pull the cooling cover (3) backward to open it.

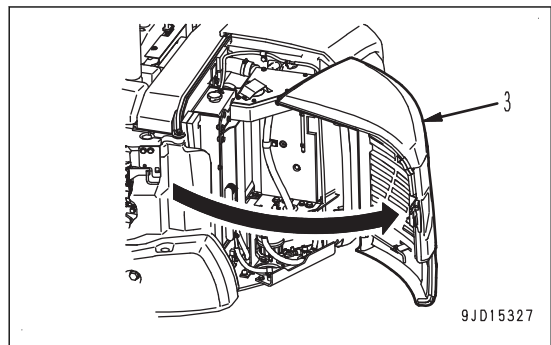

3. Turn the rod (4) to LOCK position (L), and fix the cooling cover (3) with the rod.

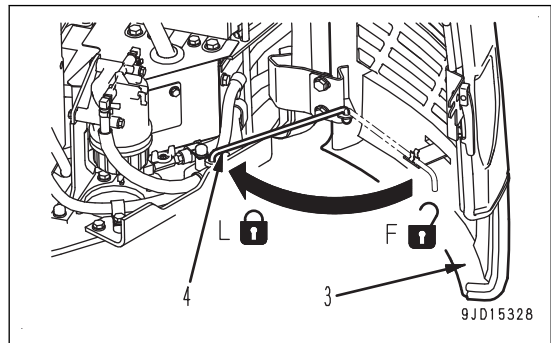

4. Check for water and sediment.
If the red ring (5) of water separator sinks at the bottom of transparent cup (6), water is not mixed.
If the red ring (5) floats, water enters up to under the red ring (5). Drain the mixed water according to the following procedure.

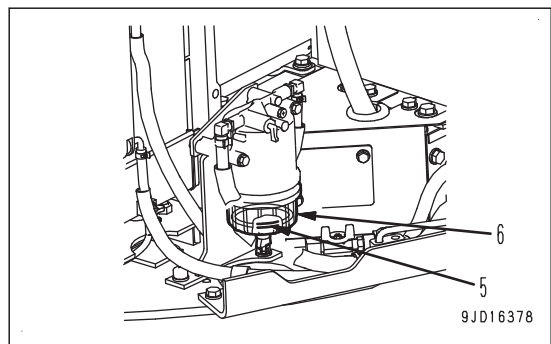

- 1) Set the machine in the posture shown in the figure.

- 1] Start the engine.
- 2] Set the lock lever to FREE position.
Be sure to operate the lock lever by the operating portion on the top.
- 3] Operate the work equipment control lever slowly to the right and left to swing the upper structure so that the fuel prefilter comes between the tracks.
- 4] Operate the work equipment control levers, and lower the work equipment to the ground.
- 5] Set the lock lever to LOCK position.
Be sure to operate the lock lever by the operating portion on the top.
- 6] Stop the engine.

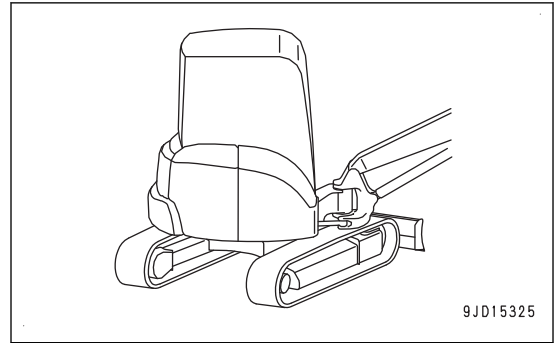

- 2) Place a container under the fuel prefilter to catch the fuel.
- 3) Turn the handle (7) to CLOSE position (S), and loosen the drain plug (8).
- 4) Drain the water until the red ring (5) contacts to the bottom of transparent cup (6).

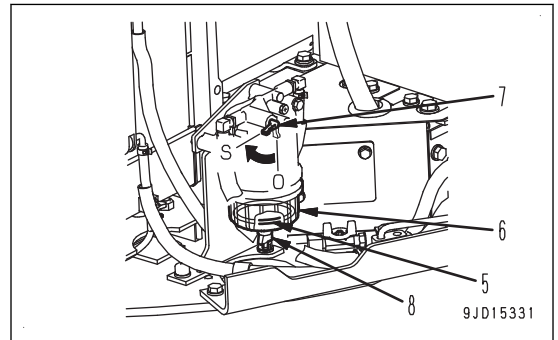

- 5) Tighten the drain plug (8), and turn the handle (7) to OPEN position (O).

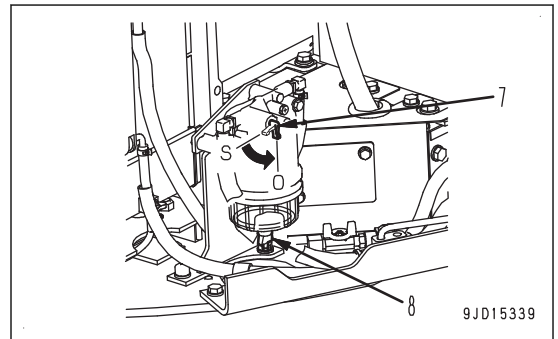

5. Turn the rod (4) to FREE position (F), and close the cooling cover (3).
6. Close the engine rear cover (1).

METHOD FOR CHECKING OIL LEVEL IN HYDRAULIC TANK, ADDING OIL

WARNING

- Immediately after the engine is stopped, its parts and oil are still very hot and may cause burn injury. Wait for the temperature to go down, and then start the work.
- When removing the oil filler cap, the oil may spurt out. Turn it slowly to release the internal pressure, then remove it carefully.

1. Set the machine in the posture shown in the figure.
If it is not set in the posture shown in the figure, set it according to the following procedure.

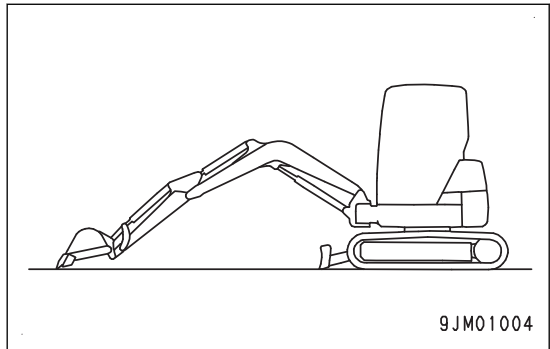

1) Start the engine.

2) Set the lock lever to FREE position (F).
Be sure to operate the lock lever by the operating portion on the top.

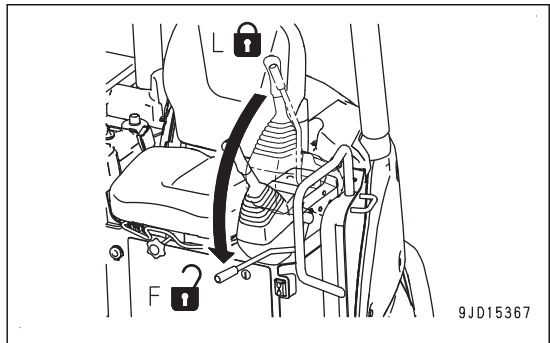

3) Operate the blade control lever to lower the blade to the ground.

4) Operate the work equipment control levers, and retract arm cylinder and bucket cylinder to their stroke end (maximum reach posture of arm and bucket).

5) Operate the boom swing control pedal to swing the boom to the center position.

6) Operate the work equipment control lever slowly to the boom LOWER direction, and lower the boom and make tooth contact to the ground.

7) Set the lock lever to LOCK position (L).
Be sure to operate the lock lever by the operating portion on the top.

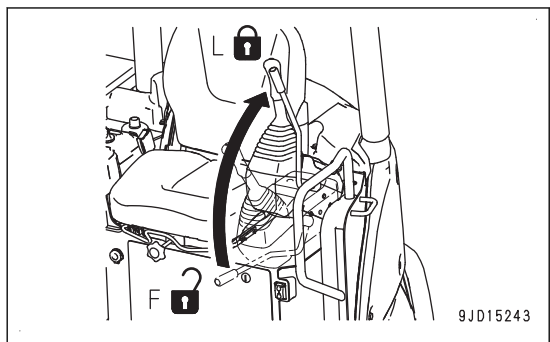

8) Stop the engine.

2. Pull the engine rear cover (1) backward to open it.
Open the engine rear cover (1) fully and it is secured by rod (2).

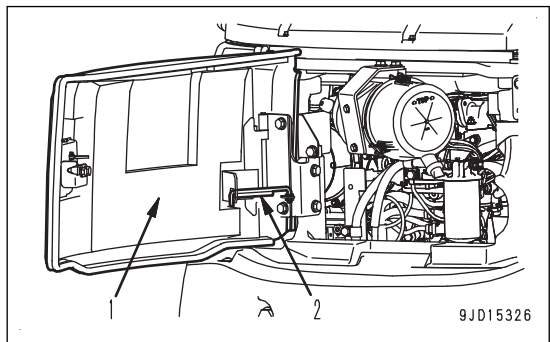

3. Pull the cooling cover (3) backward to open it.

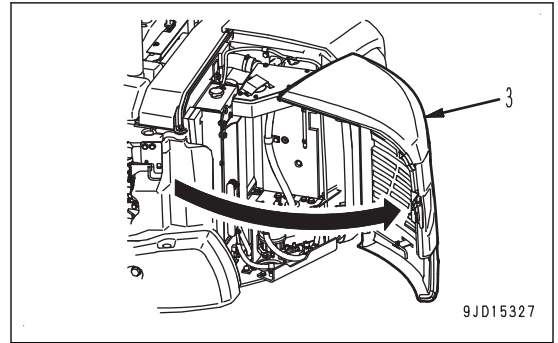

4. Turn the rod (4) to LOCK position (L), and fix the cooling cover (3) with the rod.

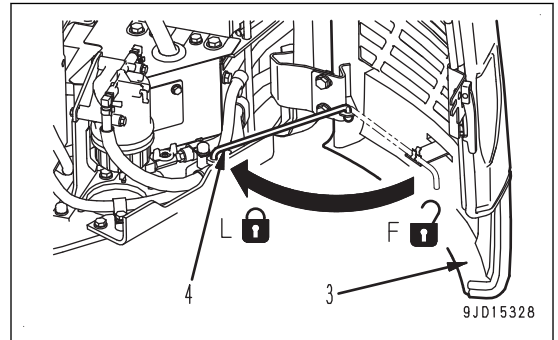

5. Check the oil level through sight gauge (G).

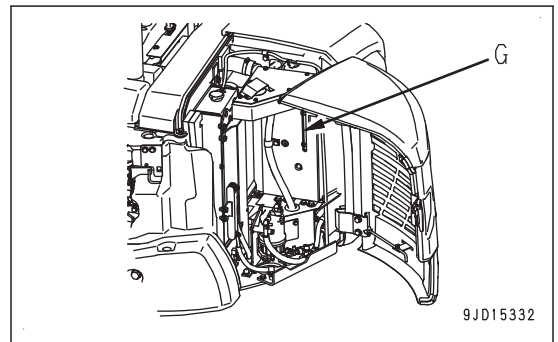

It is appropriate if the oil level is between H and L.

If the oil level is below level L, the hydraulic oil is insufficient.

If the hydraulic oil is insufficient, add oil according to the following procedure.

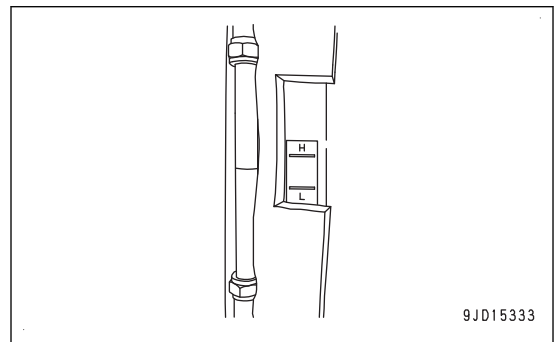

- 1) Open the dirt cover (5).
Open the dirt cover (5) fully and it will be secured by the cover support lever (6).

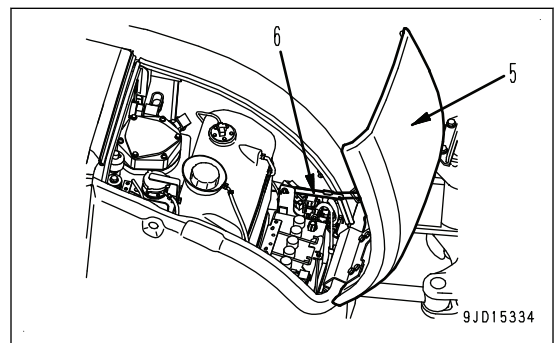

- 2) Loosen the bolt (7) of the hydraulic tank, move the plate (8) on the oil filler port (F), and turn the cap of the oil filler port (F) slowly to remove it.

Release the internal pressure.

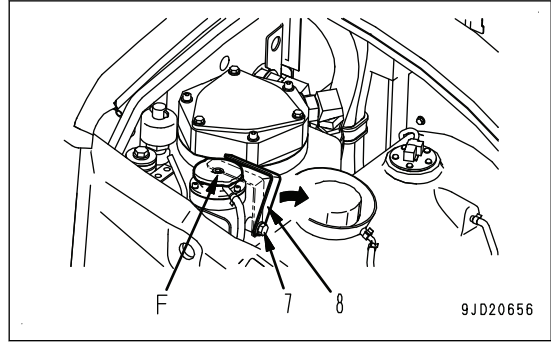

- 3) Add the hydraulic oil through oil filler port (F) until the oil level comes between levels H and L of sight gauge (G).

NOTICE

Do not add oil above H line.

It may damage the oil circuit and cause the oil to spurt out.

If oil has been added exceeding level H, swing the upper structure until the drain plug (P) under the hydraulic tank comes between the right and left tracks and stop the engine. Wait for the hydraulic oil to cool down sufficiently, then drain the excessive oil through the drain plug (P).

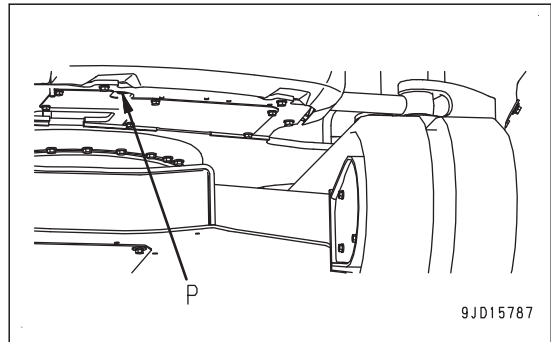

REMARK

The oil level varies with the oil temperature. Use the following as a guide for check.

Before starting the operation: Around L level

Oil temperature: 10 to 30 °C {50 to 86 °F}

In normal operation: Around H Level

Oil temperature: 50 to 80 °C {122 to 176 °F}

- 4) Start the engine.
- 5) Set the lock lever to FREE position (F).
Be sure to operate the lock lever by the operating portion on the top.

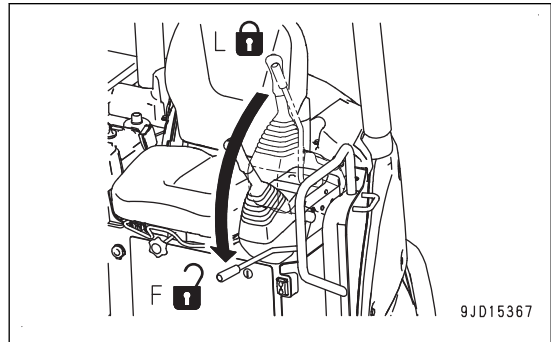

- 6) Operate the work equipment control levers, and extend the boom cylinder, bucket cylinder, and arm cylinder to their stroke end.

Set the work equipment in the posture shown in the figure.

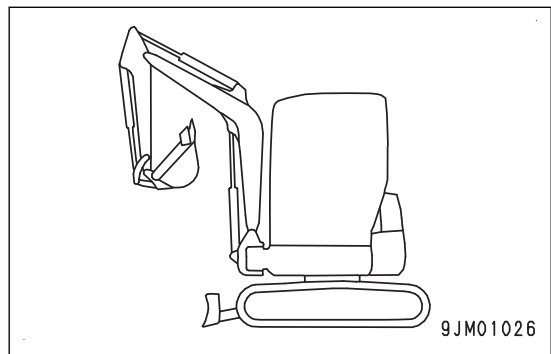

- 7) Set the lock lever securely to LOCK position (L).
Be sure to operate the lock lever by the operating portion on the top.
- 8) Stop the engine.
- 9) Tighten the cap of oil filler port (F) on the hydraulic tank securely.
By doing so, the hydraulic tank is pressurized.

NOTICE

If the hydraulic tank is not pressurized, air is sucked in the pump and it affects the components badly.

- 10) Return the plate (8) on the oil filler port (F) of the hydraulic tank to its original position, and fix it with bolt (7).
- 11) Close the dirt cover (6).
6. Turn the rod (4) to FREE position (F), and close the cooling cover (3).
7. Close the engine rear cover (1).

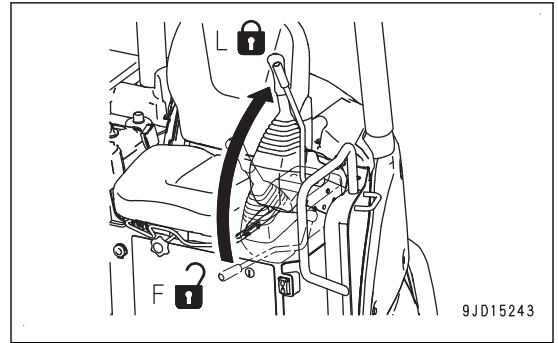

METHOD FOR CHECKING COOLANT LEVEL, ADDING COOLANT

⚠ WARNING

- Do not open the radiator cap unless necessary.
When checking the coolant level, check it with the reservoir tank when the engine is cold.
- Immediately after the engine is stopped, the coolant is hot and pressure is accumulated in the radiator.
If the radiator cap is removed in this condition, it may cause burn injury.
Always wait for the temperature to go down, turn the radiator cap slowly to release the pressure, and then remove it with care.

1. Pull the engine rear cover (1) backward to open it.
Open the engine rear cover (1) fully and it is secured by rod (2).

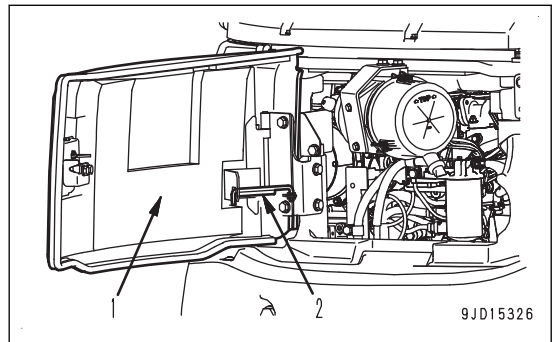

2. Pull the cooling cover (3) backward to open it.

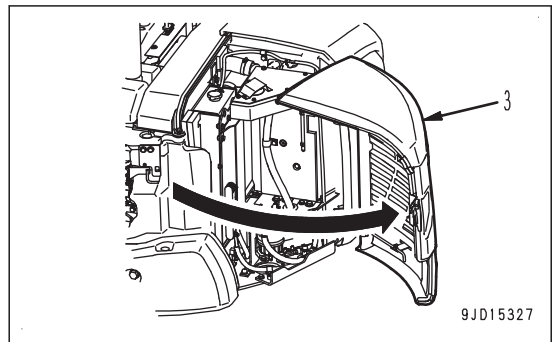

3. Turn the rod (4) to LOCK position (L), and fix the cooling cover (3) with the rod.

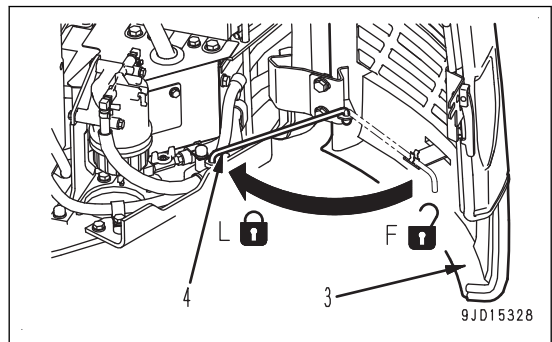

4. Check the coolant level in reservoir tank (5).

If the coolant level is within the range between FULL and LOW, the coolant amount is at a proper level.

If the coolant level is below LOW, add coolant of the same density according to the coolant density table in "METHOD FOR USING FUEL, COOLANT AND LUBRICANTS ACCORDING TO AMBIENT TEMPERATURE" to FULL of the level through the filler port of reservoir tank (5).

NOTICE

- If the reservoir tank is empty, leakage of coolant should be suspected. After checking, repair any abnormality immediately.
If no abnormality is found, check the level of the coolant in the radiator. If it is low, add coolant to the radiator first, and add it to the reservoir tank.
- If the inside of reservoir tank is so dirty that you cannot check the coolant level, clean the inside of cooling system by referring to "METHOD FOR CLEANING INSIDE OF COOLING SYSTEM".

5. Tighten the water filler cap of reservoir tank (5) securely.
6. Turn the rod (4) to FREE position (F), and close the cooling cover (3).
7. Close the engine rear cover (1).

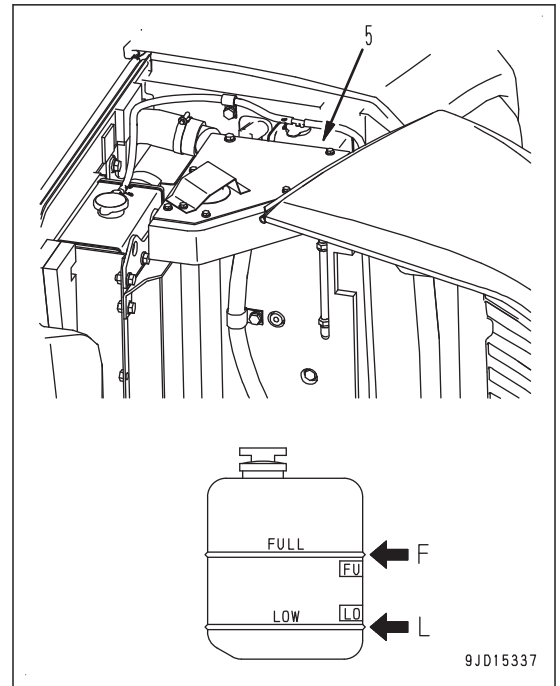

9JD15337

METHOD FOR CHECKING OIL LEVEL IN ENGINE OIL PAN, ADDING OIL

⚠ WARNING

Immediately after the engine is stopped, its parts and oil are still very hot, and may cause burn injury. Wait for the temperature to go down, and then start the work.

1. Pull engine rear cover (1) toward you to open it.
Open engine rear cover (1) fully and it is secured by rod (2).

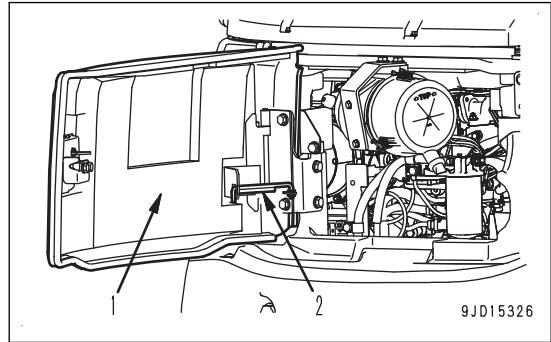

2. Pull out dipstick (G) and wipe the oil off with a cloth.
3. Fully insert dipstick (G) into the dipstick pipe, then remove it.

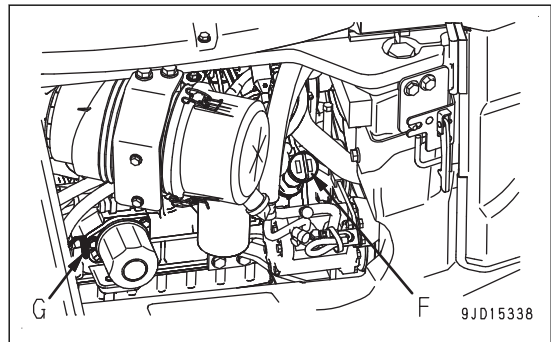

4. Check if the oil is sticking up to between marks H and L on dipstick (G).
It is appropriate if the oil level is between marks H and L.
If the oil level is below mark L, add oil through oil filler port (F).
5. If the oil level is higher than mark H, decrease it to a proper level according to the following procedure.

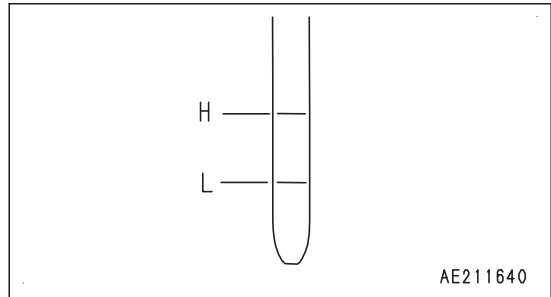

- 1) Drain excess engine oil through drain plug (P).
- 2) Check the oil level again.
6. If the oil level is proper, tighten the oil filler cap securely.
7. Close engine rear cover (1).

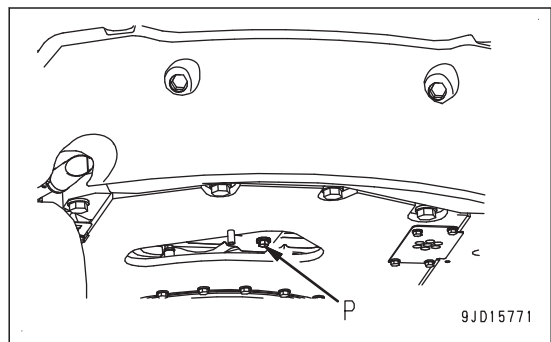

METHOD FOR CHECKING ELECTRIC WIRING** CAUTION**

- If fuses are frequently blown out or if there are traces of short-circuiting on the electric wiring, immediately ask your Komatsu distributor to locate the cause of it and to perform the repair.
 - Keep the top surface of the battery clean and check the vent hole in the battery cap. If it is clogged with dirt or dust, wash the battery cap with water to clear the vent hole.
-

NOTICE

Perform inspection for the piping of “battery”, “starting motor”, and “alternator” with extreme care.

- Perform inspection to confirm that the fuses have no defect and their capacity is proper.
- Perform inspection to confirm that there is no disconnection or trace of short-circuiting in the electric wiring and no damage to the coating.
- Perform inspection to confirm that there is no loose terminals, and tighten any loose parts if found.
- Check if there is any accumulation of combustible material around the battery, and remove such combustible material.

METHOD FOR CHECKING FUEL LEVEL, ADDING FUEL

⚠ WARNING

- Fuel is highly flammable and dangerous. Do not bring any open flame close.
- When adding fuel, never spill the fuel or let it overflow. This may cause fire.
- If any fuel has spilled, wipe it up completely. If fuel has spilled over soil or sand, remove that soil or sand.

1. Insert the key into starting switch (1) and turn it to ON position.
The machine monitor lights up.

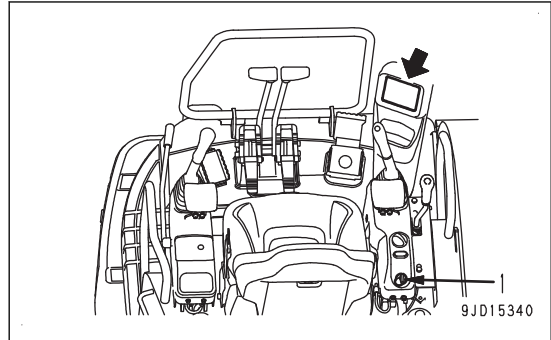

2. Check the fuel level with fuel gauge (2).
After checking, turn the starting switch (1) back to OFF position.
If the fuel level is low, add fuel according to the following procedure.

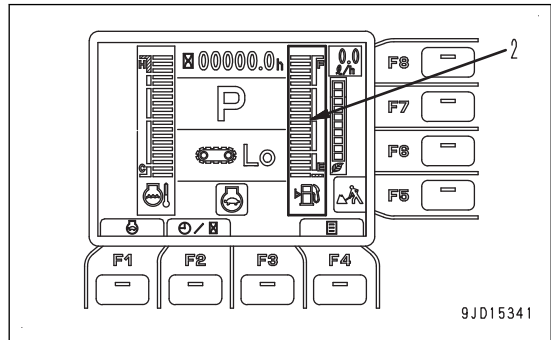

- 1) Open dirt cover (3).
Open dirt cover (3) fully and it will be secured by cover support lever (4).

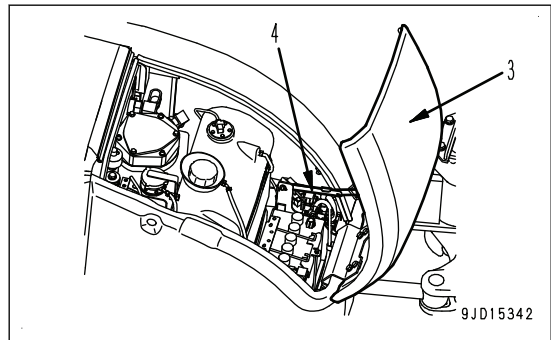

- 2) Open fuel filler port (F) and add fuel.
Check the quantity to be added with dipstick (G).
Fuel tank capacity: 65 l {17.2 U.S.Gal}

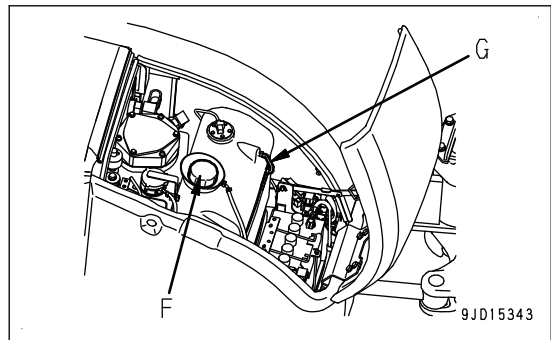

- 3) Tighten the cap of oil filler port (F) securely.

NOTICE

If breather hole (5) in the cap is clogged, the pressure inside the tank drops and this may cause the fuel to stop flowing. To prevent this, clean breather hole (5) from time to time and check there is no clogging.

- 4) Close dirt cover (3).

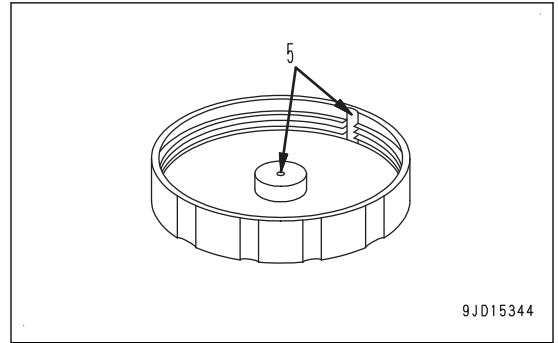

9JD15344

METHOD FOR CHECKING HORN

1. Turn the starting switch to ON position.
2. Check that the horn sounds immediately when the horn switch is pressed.

If the horn does not sound, ask your Komatsu distributor for repair.

3. After checking, turn the starting switch back to OFF position.

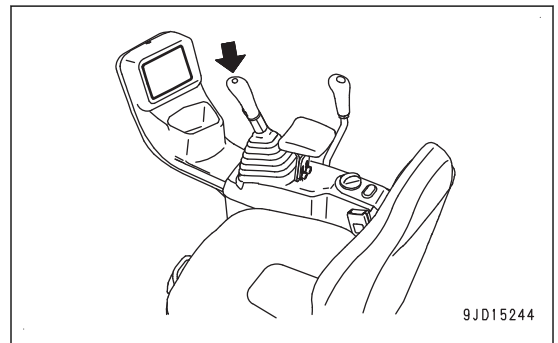

9JD15244

METHOD FOR CHECKING FLOOR TILT FIXING BOLT

! WARNING

If the floor is not securely fixed, it may lead to a serious personal injury or death.

METHOD FOR CHECKING FLOOR TILT FIXING BOLT: CANOPY SPEC

1. Remove the cover fixing bolts (1) (M8, 4 pieces), and remove the cover (2).

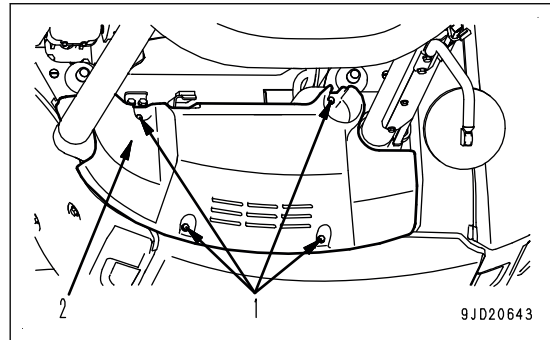

2. Check that the floor tilt fixing bolts (3) (M14, 2 pieces) in front of canopy pole are tightened securely.

If any of the floor tilt fixing bolts (3) is loosened, tighten it.

Tightening torque:

156.8 to 196.0 Nm {16.0 to 20.0 kgm, 116 to 145 lbft}

REMARK

If any of the floor tilt fixing bolts is damaged, replace it with a Komatsu genuine part of the same size.

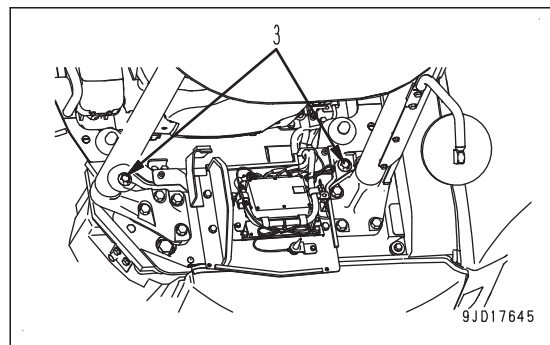

3. Pull the engine rear cover (4) backward to open it.

Open the engine rear cover (4) fully and it is secured by rod (5).

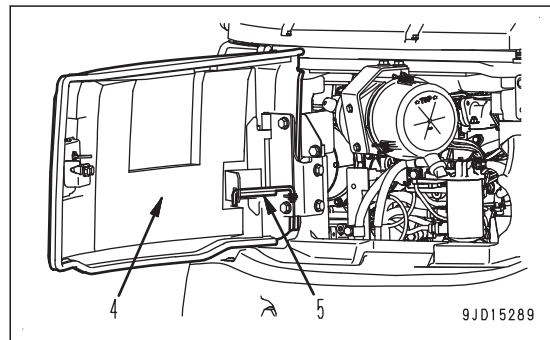

4. Check that the floor tilt fixing bolt (6) (M14, 1 piece) is tightened securely.
5. If the floor frame rattles up and down or has a clearance (a) (it is 0 mm normally), check the floor tilt fixing bolt (6). If any of the floor tilt fixing bolt (6) is loosened, tighten it.

Tightening torque:

156.8 to 196.0 Nm {16.0 to 20.0 kgm, 116 to 145 lbft}

REMARK

If any of the floor tilt fixing bolt is damaged, replace it with a Komatsu genuine part of the same size.

6. Close the engine rear cover (4).

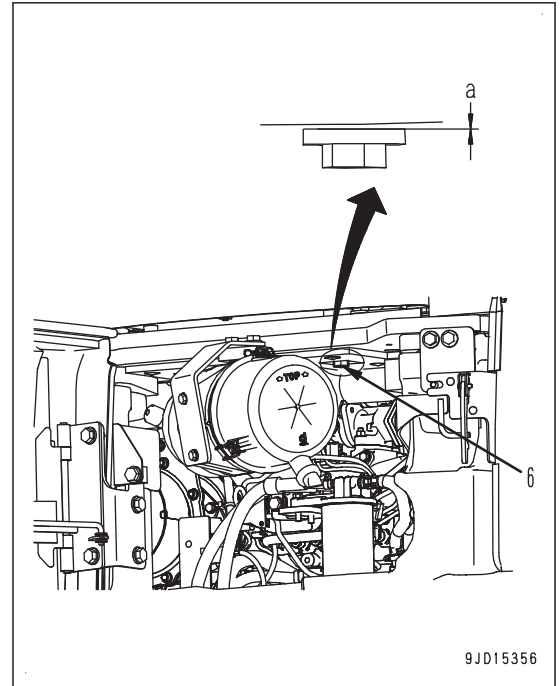

9JD15356

METHOD FOR CHECKING FLOOR TILT FIXING BOLT: CAB SPEC

1. Pull the engine rear cover (1) backward to open it.
 Open the engine rear cover (1) fully and it is secured by rod (2).

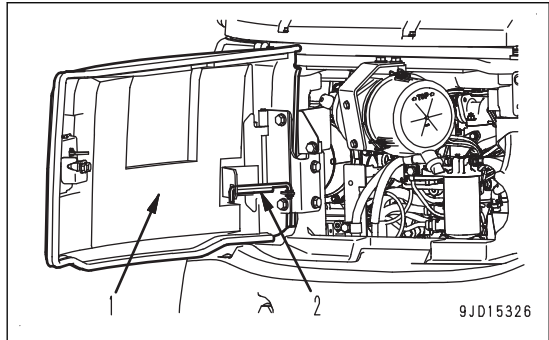

2. Check that the floor tilt fixing bolts (3) (M14, 4 pieces) are tightened securely.
3. If the floor frame rattles up and down or has a clearance (a) (it is 0 mm normally), check the floor tilt fixing bolts (3).
 If any of the floor tilt fixing bolts (3) is loosened, tighten it.

Tightening torque:
 156.8 to 196.0 Nm {16.0 to 20.0 kgm, 116 to 145 lbft}

REMARK

If any of the floor tilt fixing bolts is damaged, replace it with a Komatsu genuine part of the same size.

4. If it is loosened, retighten the bolts (2 places) in the triangle cover at the left side of the machine as well.
 For the procedure of retightening, see "METHOD FOR CLOSING FLOOR UNIT: CAB SPEC".
5. Close the engine rear cover (1).

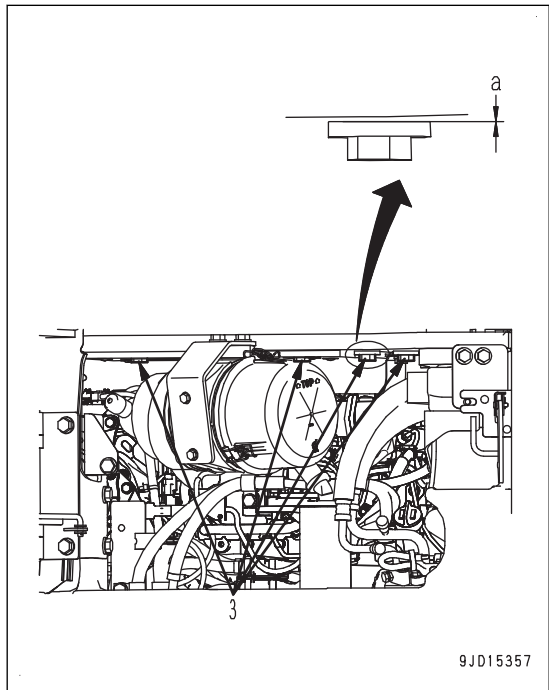

METHOD FOR ADJUSTING

METHOD FOR ADJUSTING OPERATOR'S SEAT

WARNING

When adjusting the position of the operator's seat, always set the lock lever to LOCK position to prevent any malfunction due to accidental contact with the control levers.

NOTICE

If the seat position is adjusted while the parts, tools, or empty cans are left around the operator's seat, the peripheral parts or operator's seat may be damaged.

Check that there is no parts etc., around the operator's seat, and adjust the seat position.

- Always adjust the operator's seat before starting each operation or when the operators change shift.
- Adjust the operator's seat so that control levers and switches can be operated freely and easily with the operator's back against the backrest.

METHOD FOR ADJUSTING SEAT IN FORE-AND-AFT DIRECTION

Operate lever (1) upward, set the seat to the desired position, and then release the lever.

Fore-aft adjustment: 180 mm {7.1 in}

REMARK

Adjust the position of operator's seat according to the type of the work. For example, slide the seat forward for deep digging work, so that you can get better visibility downward.

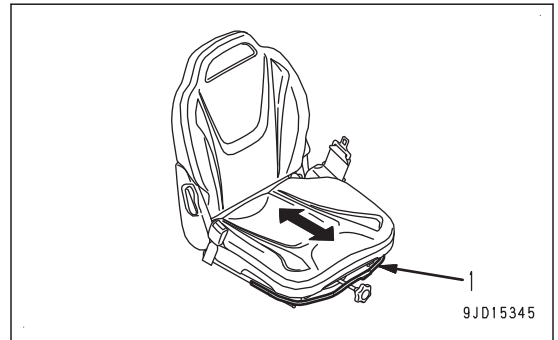

METHOD FOR RECLINING SEAT

Operate lever (2) upward, set the backrest to the desired position, and then release the lever.

REMARK

Sit with your back against the backrest when adjusting. If your back is not touching the backrest, it may suddenly move forward.

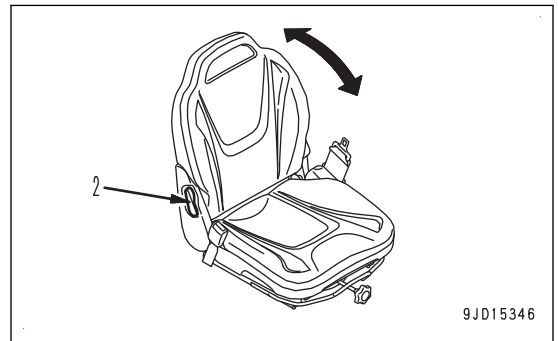

METHOD FOR ADJUSTING SEAT SUSPENSION

Turn knob (3) under the seat to adjust it to your desired position.

Weight adjustment range: 50 to 120 kg {110.6 to 264.6 lb}

REMARK

To make the seat softer, adjust the weight to make it lighter; to make the seat harder, adjust the weight to make it heavier. When traveling on rough road surfaces, make the seat harder in advance.

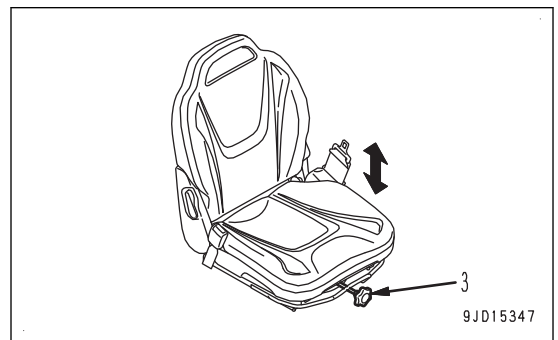

METHOD FOR ADJUSTING MIRRORS

WARNING

Be sure to adjust the mirrors before starting work.

If they are not adjusted properly, you cannot secure the visibility and may lead to a serious personal injury or death.

CAUTION

The following conditions must be met before starting the work to prevent the machine from moving during the work.

- The machine is placed on a level ground.
- The work equipment is lowered to the ground in secure posture.
- The lock lever is in LOCK position.
- The engine is stopped.

METHOD FOR ADJUSTING MIRRORS: CANOPY SPEC

Mirror (A)

Left front mirror

Mirror (B)

Right front mirror

Mirror (C)

Right rear mirror

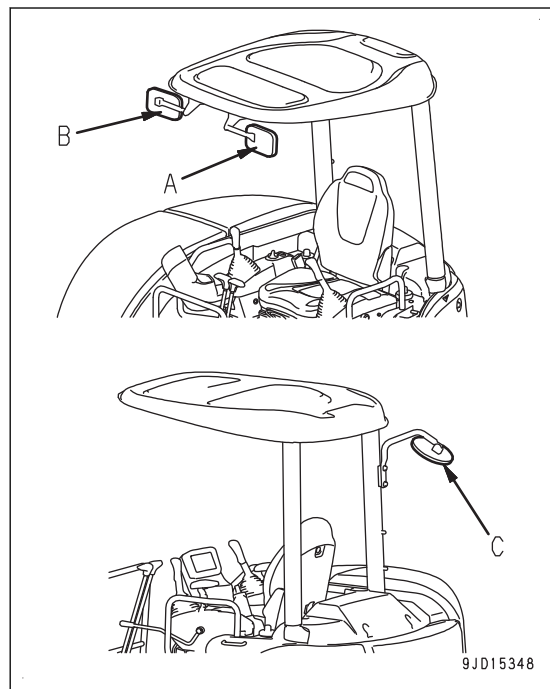

METHOD FOR ADJUSTING MIRRORS: CAB SPEC

Mirror (A)

Left front mirror

Mirror (B)

Right front mirror

Mirror (C)

Right rear mirror

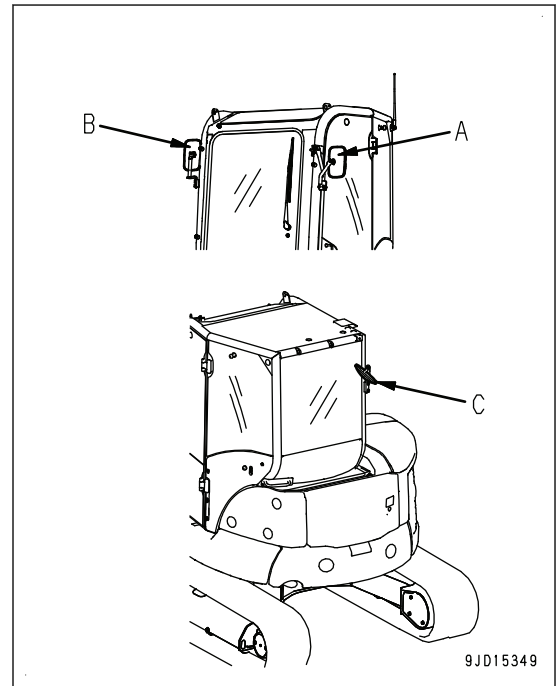

PROCEDURE FOR ADJUSTING MACHINE LEFT FRONT MIRROR

CAUTION

The following conditions must be met before starting the work to prevent the machine from moving during the work.

- The machine is placed on a level ground.
- The work equipment is lowered to the ground in secure posture.
- The lock lever is in LOCK position.
- The engine is stopped.

Adjust the mirror so that the operator can see a person at the rear left of the machine.

1. Adjust the mirror so that the side of the machine is reflected in the mirror as shown in the figure.
2. Check that you can see a person at the rear left end of the machine.

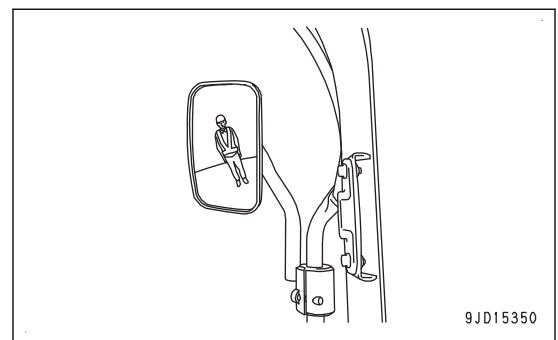

PROCEDURE FOR ADJUSTING MACHINE RIGHT FRONT MIRROR

⚠ CAUTION

The following conditions must be met before starting the work to prevent the machine from moving during the work.

- The machine is placed on a level ground.
- The work equipment is lowered to the ground in secure posture.
- The lock lever is in LOCK position.
- The engine is stopped.

1. Adjust the mirror so that the side of the machine is reflected in the mirror as shown in the figure.
2. Check that you can see a person at the rear right of the machine.

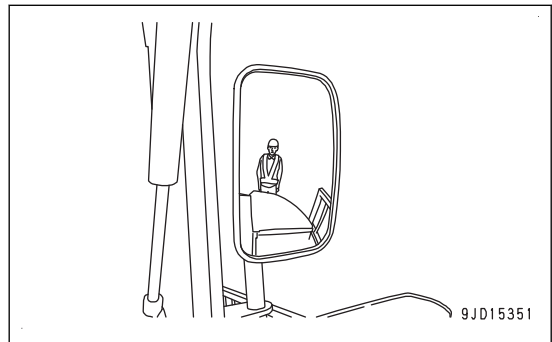

PROCEDURE FOR ADJUSTING MACHINE RIGHT REAR MIRROR

⚠ CAUTION

The following conditions must be met before starting the work to prevent the machine from moving during the work.

- The machine is placed on a level ground.
- The work equipment is lowered to the ground in secure posture.
- The lock lever is in LOCK position.
- The engine is stopped.

Adjust it so that people at 1 m {3 ft 3 in} behind the machine can be seen from the operator's seat.
(W): 1 m {3 ft 3 in}

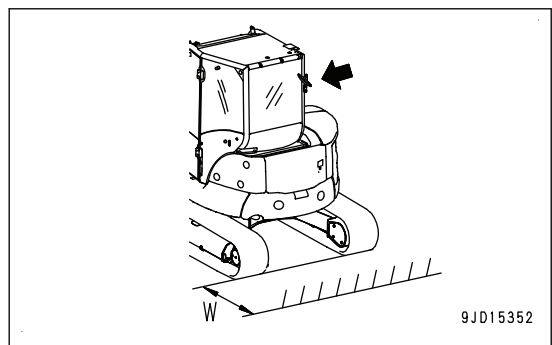

METHOD FOR FASTENING AND UNFASTENING SEAT BELT

⚠ WARNING

- Before fastening the seat belt, check that there is no problem in the belt mounting bracket or belt. If it is worn or damaged, replace it.
- Even if no problem can be seen in the belt, replace the seat belt every 3 years from starting usage or 5 years after manufacture whichever comes sooner.
- Be sure to use the seat belt during operation.
- Do not twist the seat belt when fastening.

REMARK

- The date of manufacture of the belt is shown on the back of the belt.
- The date indicated on the seat belt is the manufactured date. It is the start of the 5-year period. It is not the start of the 3-year period of actual usage.
- This seat belt has a retractable device, so it is not necessary to adjust the length.

METHOD FOR FASTENING SEAT BELT

1. Hold grip (2) and pull out the belt from retractable device (1).
2. Check that the belt is not twisted, and then inset tongue (3) into buckle (4) securely.
3. Pull the belt lightly to check that it is properly set.

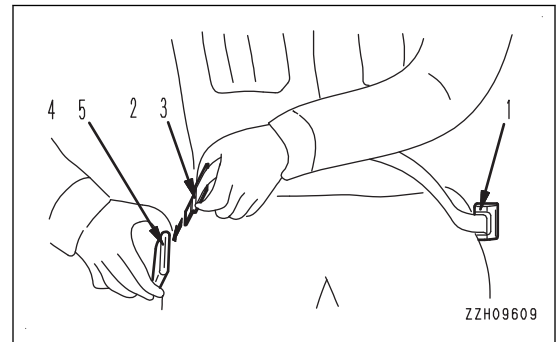

METHOD FOR UNFASTENING SEAT BELT

1. Hold grip (2) and press button (5) of buckle (4). Tongue (3) comes off buckle (4).

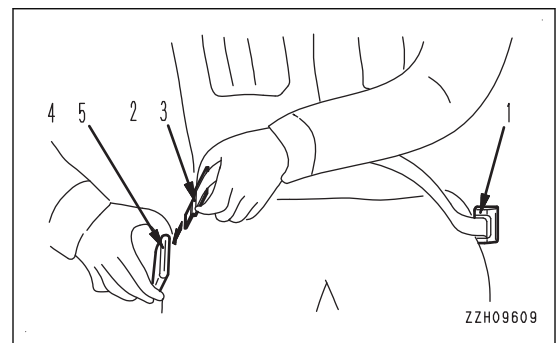

2. The belt is automatically wound in. Return the belt slowly to retractable device (1).

REMARK

If the tongue of seat belt is not inserted in the buckle, the seatbelt caution lamp is displayed at the top left of the machine monitor.

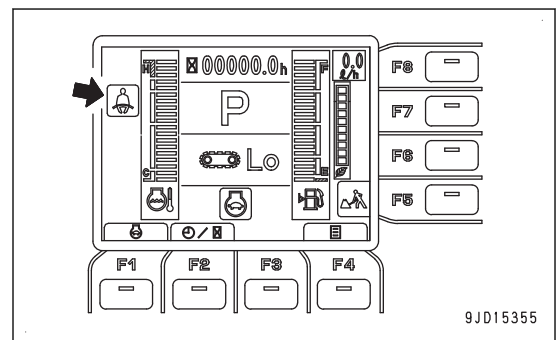

METHOD FOR OPERATIONS AND CHECKS BEFORE STARTING ENGINE

⚠ WARNING

When starting the engine, check that the lock lever is securely at LOCK position.

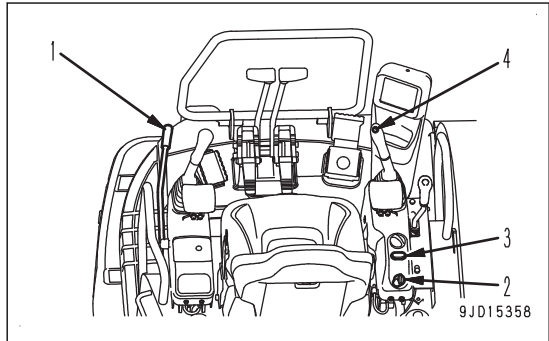

1. Check that the lock lever (1) is at LOCK position (L).
If the lock lever (1) is in FREE position (F), the engine does not start.
2. Check that each lever is in NEUTRAL position.

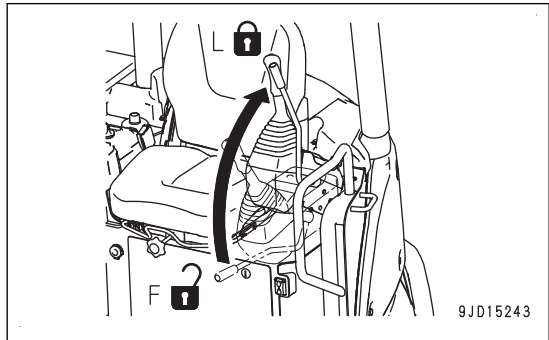

3. Insert the key into the starting switch (2) and turn it to ON position (B).

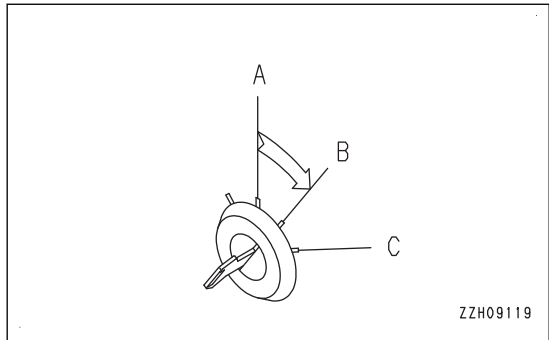

4. Check the machine monitor.
Check the machine monitor according to the following procedure.
 - If the caution lamp and action level stay lit in red for 30 seconds, perform the inspection immediately.
For the contents and check methods for caution lamp, see "WARNING DISPLAY".

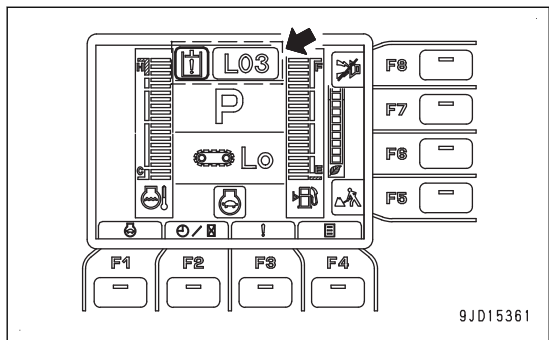

- If the maintenance time caution lamp is lit in red, press the function switch “F4” to find the item over the maintenance due time, and perform the maintenance immediately.

The maintenance caution lamp goes out after 30 seconds.

For the method of checking the maintenance time, see EXPLANATION OF COMPONENTS, “MAINTENANCE SCREEN SETTING”.

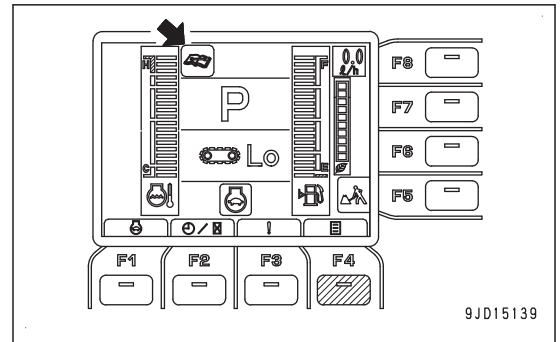

5. Press the lamp switch (3) and check if the working lamps light up.

If the working lamps do not light up, broken bulb or wire breakage is suspected. Ask your Komatsu distributor for repair.

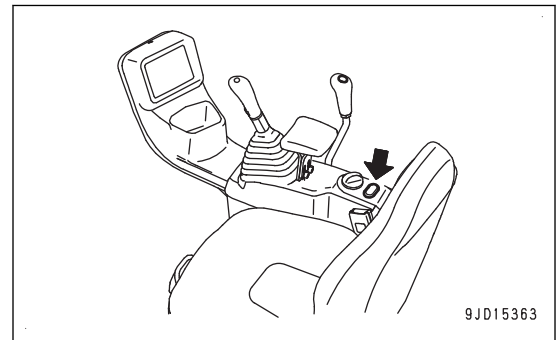

6. Press the horn switch (4) and check that the horn sounds.

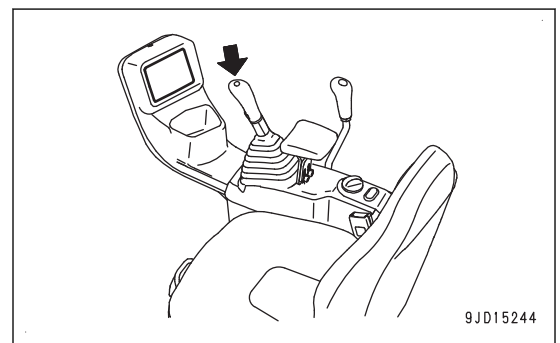

METHOD FOR STARTING ENGINE

⚠ WARNING

- Start the engine only while sitting on the operator's seat.
- Do not attempt to start the engine by short-circuiting the engine starting circuit. Doing so may cause a fire or serious personal injury or death.
- Check that there are no persons or obstacles in the area around the machine, then sound the horn and start the engine.
- Exhaust gas is toxic. When starting the engine in confined spaces, be particularly careful to ensure good ventilation.
- When operating the machine, always keep the covers closed unless you perform inspection.

NOTICE

Do not turn the starting motor continuously for 20 seconds or longer.
 If the engine does not start, wait for 2 minutes or so, and then try to start the engine again.

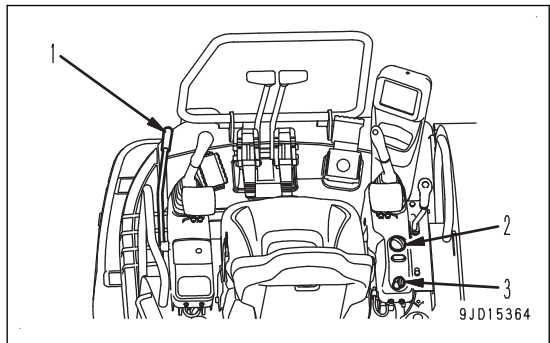

1. Check that lock lever (1) is at LOCK position (L).
 If lock lever (1) is at FREE position (F), the engine does not start.

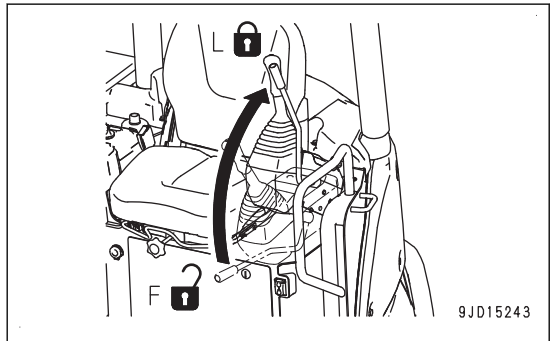

2. Turn fuel control dial (2) to Low idle (MIN) position.

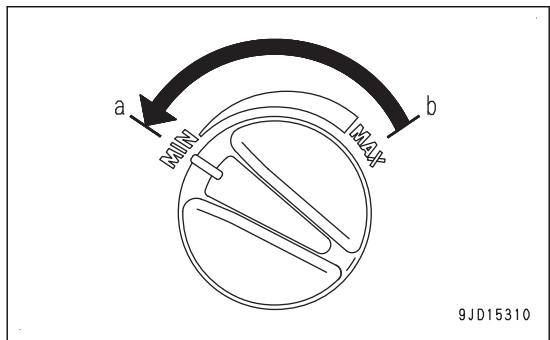

- Turn the key in starting switch (3) to ON position (B).

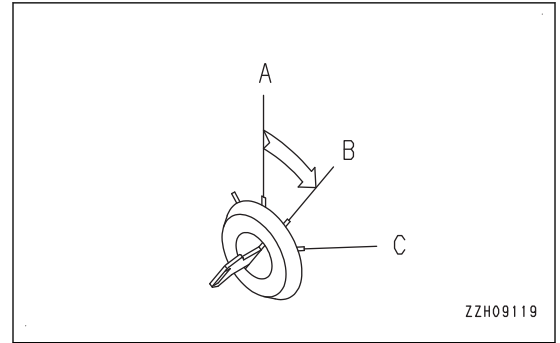

REMARK

If the ambient temperature is low, the preheating pilot lamp lights up and automatic preheating is performed. Keep starting switch (3) key at ON position (B) until the preheating pilot lamp goes out. The time that the preheating pilot lamp stays lit depends on the ambient temperature as shown in the table.

Ambient temperature	Lighting time
-15 °C or higher {5 °F or higher}	0 to 15 seconds
-15 °C or lower {5 °F or lower}	15 seconds

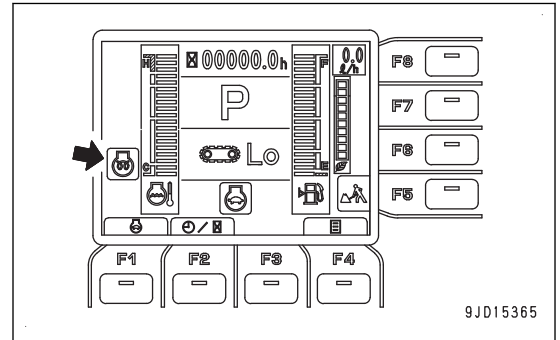

- If the preheating pilot lamp does not light up, or it lights up and then goes out to inform that the engine preheating has been completed, turn the key in starting switch (3) to START position (C).
The engine starts.

REMARK

When the ambient temperature is low, the engine may not start even if the key in starting switch (3) is kept at START position for 20 seconds. If this happens, wait for at least 2 minutes, then start again from the beginning.

- When the engine starts, release the key in starting switch (3).

The key in starting switch (3) automatically returns to ON position (B).

REMARK

At starting of the engine, battery voltage may drop abruptly depending on the ambient temperature or battery condition, and the machine monitor may restart, but it is not a trouble.

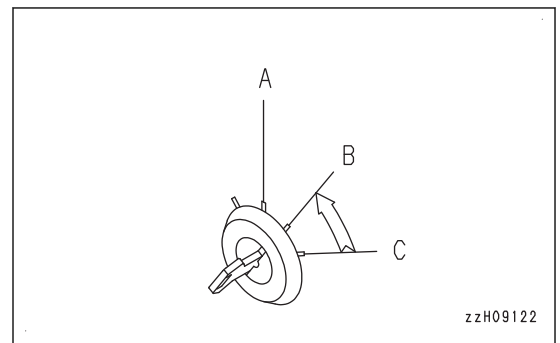
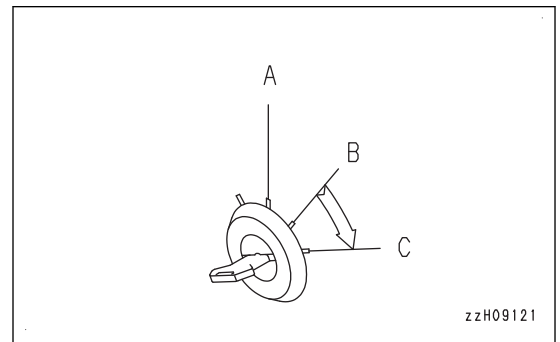

- After the engine starts, wait for the engine oil pressure caution lamp to go out. Do not touch the control levers or control pedal while the engine oil pressure caution lamp is lit.

NOTICE

If the engine oil pressure caution lamp does not go out in 4 to 5 seconds, stop the engine immediately. Check the oil level, oil leakage, etc. and take proper measures.

REMARK

White smoke may be discharged for a short time immediately after the engine is started or during the aftertreatment devices regeneration in the cold season, but this is not a failure.

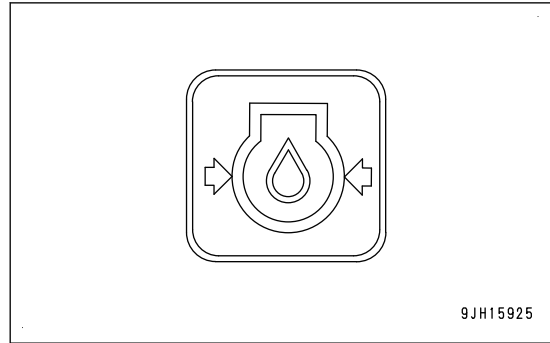

METHOD FOR OPERATIONS AND CHECKS AFTER STARTING ENGINE

WARNING

- If there is any trouble such as emergency stop, abnormal actuation, etc., turn the starting switch key to OFF position.
- Perform the warm-up operation for the hydraulic component thoroughly, the control levers and pedals are slow to react, and the machine may not move according to the operator's intention if the hydraulic component is not warm enough. Particularly in a cold weather, perform the warm-up operation for the hydraulic component thoroughly.
- Do not approach the exhaust pipe of the engine while the engine is running or just after it is stopped.
- Keep combustible materials away from the exhaust pipe outlet.

- There are 2 types of warm-up operation: warm-up of the engine and warm-up of the hydraulic component. In addition, depending on the environment, the method of performing the warm-up operation may differ, so perform the warm-up operation according to the descriptions given in the appropriate section.
- The hydraulic component is not warmed by simply performing engine warm-up operation. Perform the warm-up operations for the hydraulic component separately from that for the engine. Perform the warm-up operation for the hydraulic component, so that the hydraulic oil is also warmed up and it circulates in all the control circuits.

METHOD FOR CHECKING STARTING CONDITION AND UNUSUAL NOISE OF ENGINE

- When starting the engine, check that the engine causes no abnormal noise and that it starts up easily and smoothly.
- Check that there is no abnormal noise when the engine is idling or when the engine speed rises slightly.

When there is an abnormal noise at the engine startup and if that condition continues, the engine may be damaged. In that case, ask your Komatsu distributor to check the engine as soon as possible.

METHOD FOR CHECKING LOW-SPEED RUN AND ACCELERATION OF ENGINE

CAUTION

- Perform these checks in a safe place, watching out for danger in the surroundings.
 - When the engine performs very badly at low idle and in the acceleration and if that condition continues, it may damage the engine or confuse the operator's sense of driving or lower the braking efficiency, and as a result lead to an unexpected accident. In that case, ask your Komatsu distributor to check the engine as soon as possible.
- When stopping the machine during the normal traveling operation, check that the engine does not hunt or stop suddenly.
 - Check that the engine speed rises smoothly when the fuel control dial is turned to High idle (MAX) position.

REMARK

- The smell of the exhaust gas is different from that of the conventional diesel engine because of the exhaust gas filtering function.
- White smoke may be discharged for a short time immediately after the engine is started or during the after-treatment devices regeneration in the cold season, but this is not a failure.

METHOD FOR RUNNING-IN THE NEW MACHINE

NOTICE

Your Komatsu machine has been thoroughly adjusted and tested before shipment from the factory. However, operating the machine under full load before breaking the machine in can adversely affect the performance and shorten the machine life.

Be sure to break in the machine for the initial 100 hours (as indicated on the service meter).

Make sure that you fully understand the descriptions in this manual, then run in the machine while paying attention to the following points.

- Run the engine at idle for 15 seconds immediately after starting it up.
Do not operate the control levers or fuel control dial during this time.
- Perform warm-up operation for 5 minutes after the engine is started.
- Avoid operation with heavy loads or at high speeds.
- Immediately after starting the engine, avoid sudden starts, sudden acceleration, unnecessary sudden stops, and sudden changes in direction of the machine.

METHOD FOR ENGINE WARM-UP OPERATION

NOTICE

- Do not perform operations or operate the levers sharply while the hydraulic oil is at low temperature.
Be sure to perform the warm-up operation.
This will extend the service life of the machine.
- Do not suddenly accelerate the engine before the warm-up operation is completed.
- Do not run the engine at low idle or high idle under no load for 20 minutes or more.

After the engine starts, do not start operating the machine immediately. First, perform the following operations and checks.

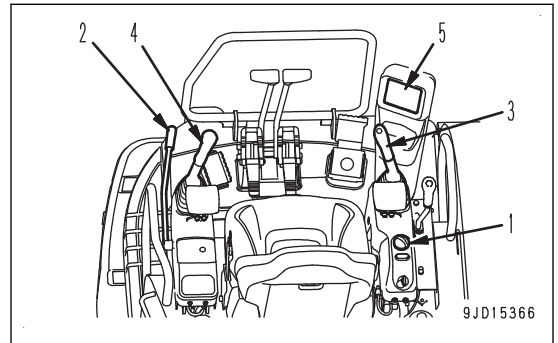

1. Before starting the operation, turn fuel control dial (1) to midpoint (c) between Low idle (MIN) position (a) and High idle (MAX) position (b).

Run the engine at medium speed with no load for approximately 5 minutes.

REMARK

If the ambient temperature is 0 °C and below {32 °F and below}, perform warm-up operation with fuel control dial (1) to be throttled to approximately 1/4.

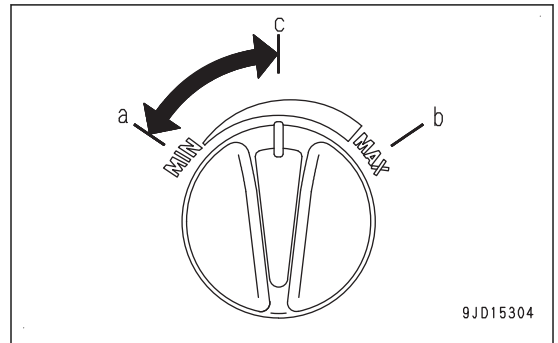

2. Move lock lever (2) slowly and securely to FREE position (F).

Be sure to operate the lock lever (2) by the operating portion on the top.

Operate R.H. and L.H. work equipment control levers (3) and (4) slowly to raise the bucket from the ground.

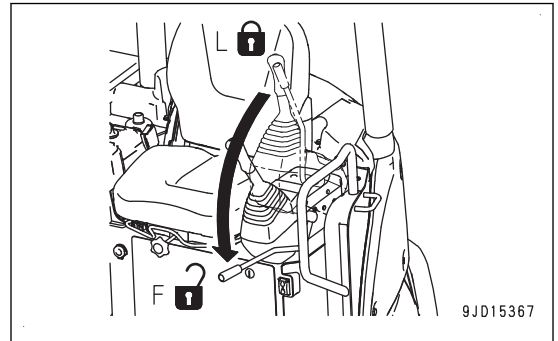

3. Operate R.H. work equipment control lever (3) slowly to set it to bucket CURL position (c).

Keep it at bucket CURL position (c) for 5 minutes.

Bucket operation

CURL (c) ↔ DUMP (d)

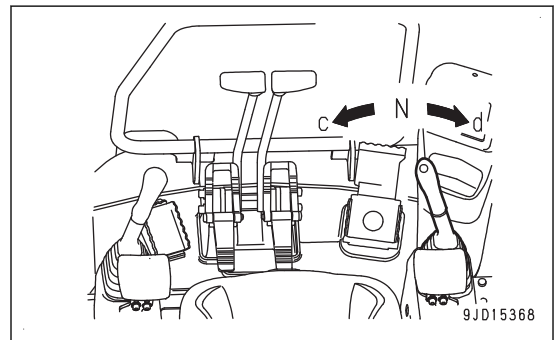

4. After warm-up operation, check that machine monitor (5) is in the following conditions.

(6) Engine coolant temperature gauge

The graduation of gauge is within normal range.

(7) Fuel gauge

The graduation of gauge is within normal range.

(8) Caution lamp display

OFF

If any problem is found, perform maintenance or repair.

5. Check for abnormal exhaust gas color, noise, or vibration.
If any abnormality is found, contact your Komatsu distributor.
6. Set lock lever (2) to LOCK position (L).
Be sure to operate the lock lever (2) by the operating portion on the top.
7. Operate the following levers and pedals, and check that the machine does not move.

- Work equipment operation and swing operation cannot be done by R.H. and L.H. work equipment control levers.
- Machine does not travel by operating R.H. and L.H. travel levers.
- Blade does not move by operating blade control lever.
- Boom does not swing by operating boom swing control pedal.

Warm-up operation of the engine is completed.

Then, perform the warm-up operation for the hydraulic components.

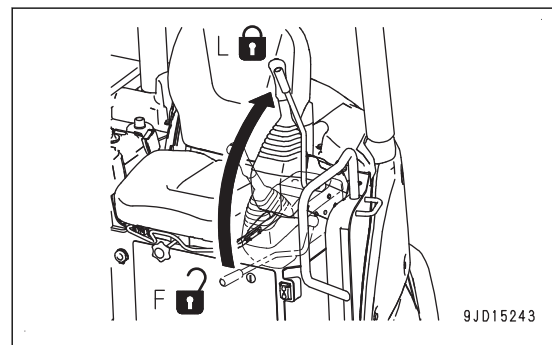
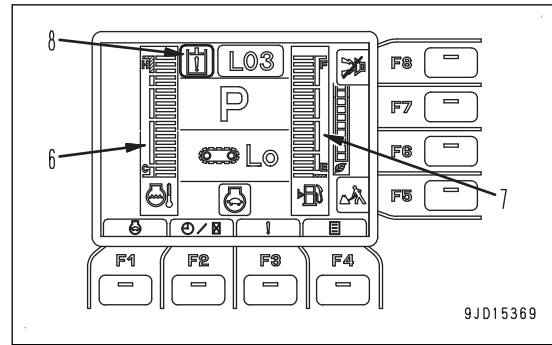

METHOD FOR HYDRAULIC SYSTEM WARM-UP OPERATION

⚠ WARNING

- Before warming up the hydraulic component, check that there is no person or obstacle in the area around the machine, then sound the horn and start the operation.
- The warm-up operation for the hydraulic component is necessary not only for the circuit between the pump and cylinders and between the pump and motor, but also for the control circuits.
Do not perform the operation just for one cylinder or motor, or the operation just in one direction. Perform the operation in all directions for all the work equipment (boom, arm and bucket), swing, travel, and attachment (if equipped).
- Check the direction of the track frame before operating the travel lever.

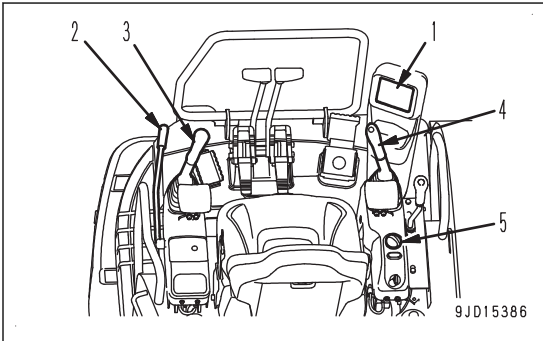

1. Set the working mode to P mode on the machine monitor (1).

It quickens the warm-up of the hydraulic component.
For the working mode setting, see “WORKING MODE SELECTION”.

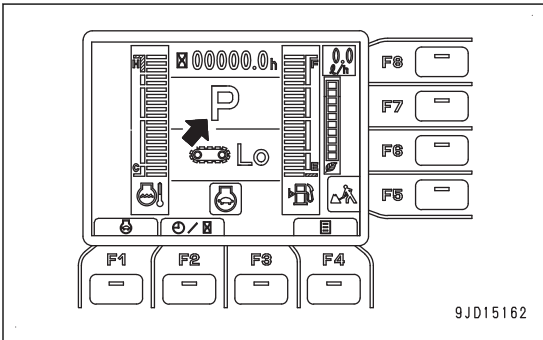

2. Move the lock lever (2) slowly and securely to FREE position (F).

Be sure to operate the lock lever (2) by the operating portion on the top.

Operate the R.H. and L.H. work equipment control levers (3) and (4) slowly to raise the bucket from the ground.

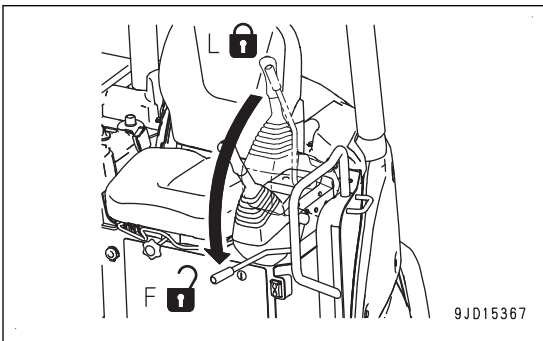

3. Turn the fuel control dial (5) to the point (c) of 2/3 between Low idle (MIN) position (a) and High idle (MAX) position (b).

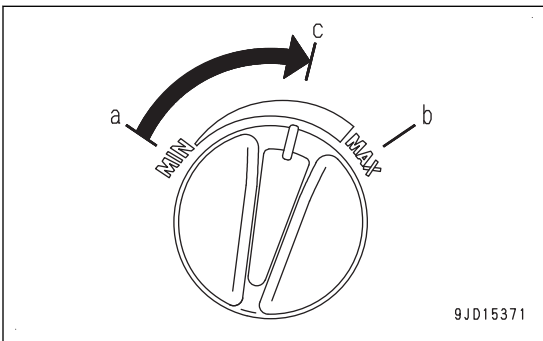

4. Operate the R.H. and L.H. work equipment control levers (3) and (4) to warm up the hydraulic components.

Repeat the operation of the R.H. and L.H. work equipment control levers (3) and (4) for 5 minutes.

NOTICE

When the work equipment is operated, take care that it does not interfere with the machine or ground.

- 1) Operate the R.H. work equipment control lever (4) slowly to set it to bucket CURL position (m).
Keep the lever at bucket CURL position (m) for 30 seconds.
- 2) Operate the R.H. work equipment control lever (4) slowly to set it to the bucket DUMP position (k).
Keep the lever at the bucket DUMP position (k) for 30 seconds.
- 3) Operate the L.H. work equipment control lever (3) slowly to set it to the arm IN position (f).
Keep the lever at the arm IN position (f) for 30 seconds.
- 4) Operate the L.H. work equipment control lever (3) slowly to set it to the arm OUT position (g).
Keep the lever at the arm OUT position (g) for 30 seconds.

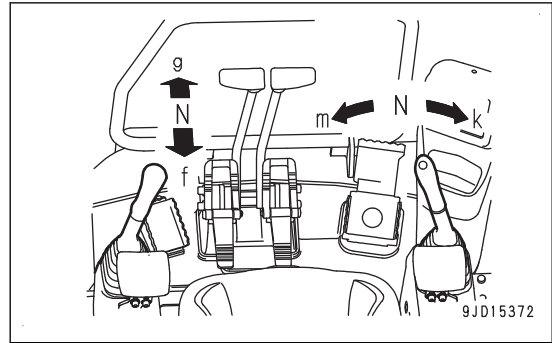

5. After the warm-up operation, check that the machine monitor (1) is in the following conditions.

(6) Engine coolant temperature gauge

The graduation of gauge is within normal range.

(7) Fuel gauge

The graduation of gauge is within normal range.

(8) Caution lamp display

OFF

If any problem is found, perform maintenance or repair.

6. Check for abnormal exhaust gas color, noise, or vibration.
If any problem is found, contact your Komatsu distributor.
7. In cold weather (ambient temperature is less than 0 °C {less than 32 °F}), perform the warm-up operation for hydraulic system in cold weather.

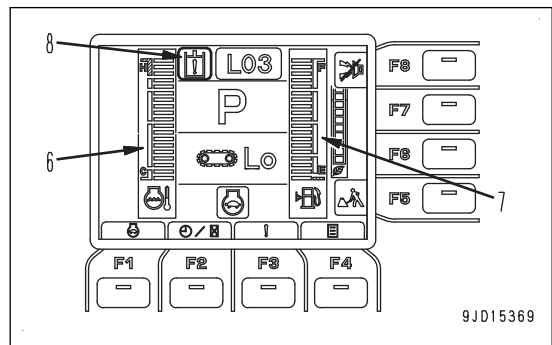

NOTICE

Warm-up all the hydraulic component by performing the warm-up operation for hydraulic system in cold weather (ambient temperature is less than 0 °C {less than 32 °F}), even when the display shows the correct temperature.

Perform the warm-up operation for hydraulic system in cold weather according to the following procedure.

- 1) Turn the fuel control dial (5) to High idle (MAX) position (b).
- 2) Repeat the work equipment operation in step 4 for 3 to 5 minutes.

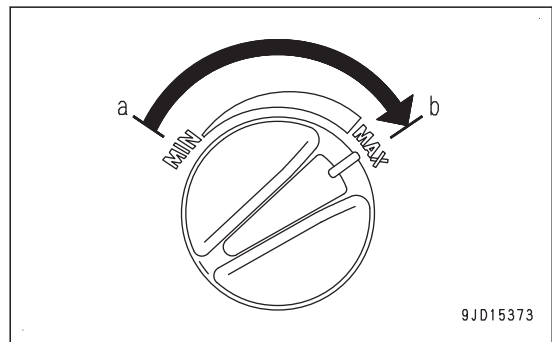

8. Before starting the operation, turn the fuel control dial (5) to the point (c) of 2/3 between Low idle (MIN) position (a) and High idle (MAX) position (b).

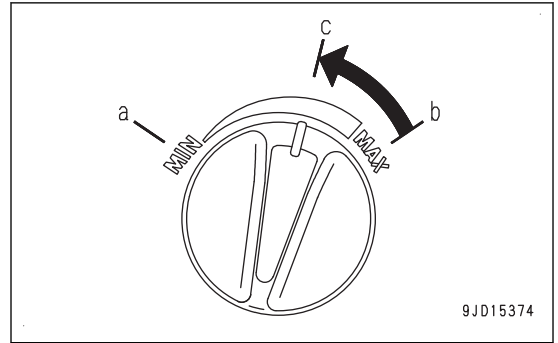

9. Operate each control lever and control pedal to circulate the warm hydraulic oil to all control circuits. Repeat the following operation slowly 3 to 5 times before starting the actual work.

Boom operation

RAISE (h) ↔ LOWER (j)

Arm operation

IN (f) ↔ OUT (g)

Bucket operation

CURL (m) ↔ DUMP (k)

Swing operation

RIGHT (d) ↔ LEFT (e)

Travel (Lo) operation

FORWARD (n) ↔ REVERSE (p)

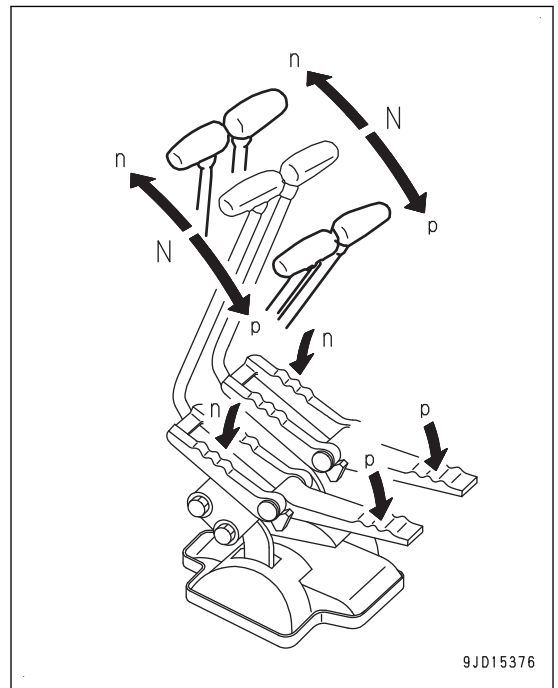
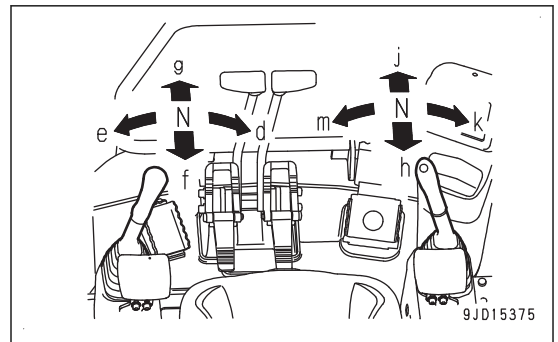

Boom swing operation

RIGHT (q) ↔ LEFT (r)

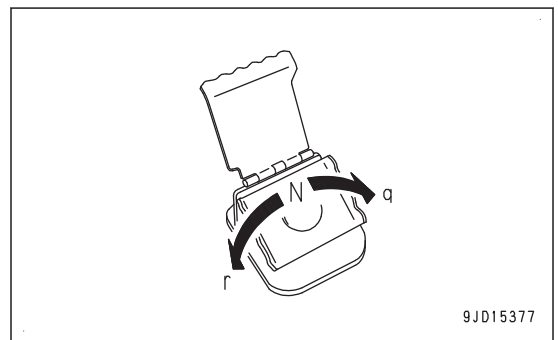

Blade operation

LOWER (s) ↔ RAISE (t)

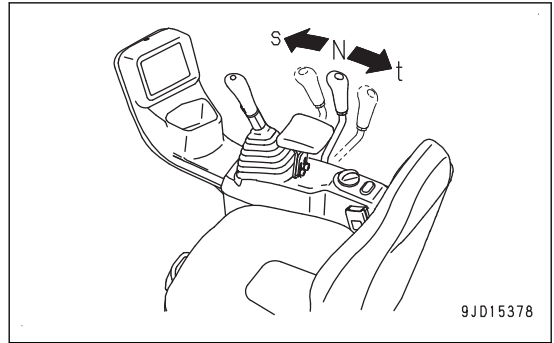

Attachment operation

(if equipped)

(For the machine equipped with attachment control pedal)

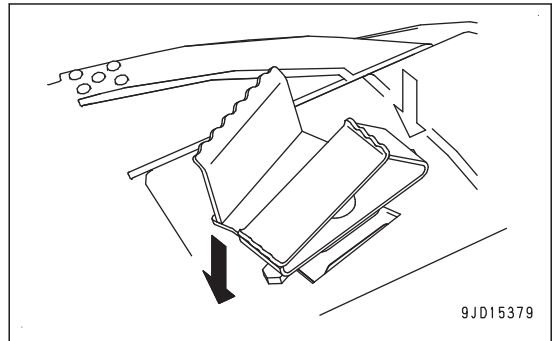

(For the machine equipped with proportional lever)

For attachment operations, change the working mode to the attachment mode to perform.

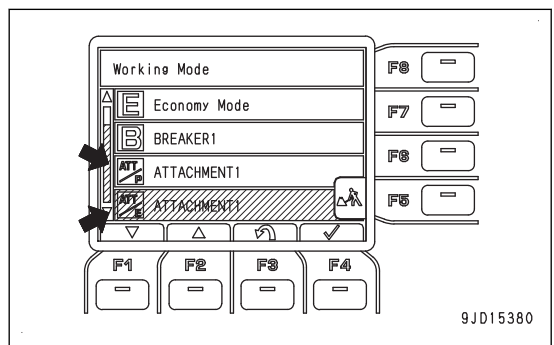
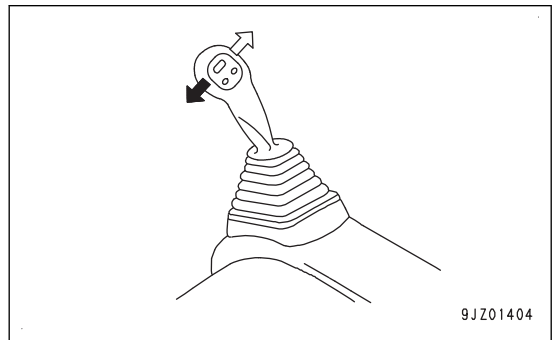

Warm-up operation for hydraulic component is completed.

METHOD FOR STOPPING ENGINE

WARNING

Keep away from the exhaust pipe immediately after stopping the engine.

NOTICE

- Do not stop the engine abruptly except in an emergency. Otherwise, the service lives of component parts of the engine will be reduced.
If the engine is overheated, do not try to stop it abruptly but run it at medium speed to allow it to cool down gradually, and then stop it.
- If the engine is stopped during the aftertreatment devices regeneration, the components may be damaged.
While the aftertreatment devices regeneration is being performed, stop the aftertreatment devices regeneration first according to “PROCEDURE FOR AFTER-TREATMENT DEVICES REGENERATION DISABLE SETTING”, run the engine at low idle for approximately 5 minutes, and then stop the engine.

REMARK

If the starting switch is turned to ON position or START position soon after the engine is stopped, the engine coolant temperature gauge may point the red range momentarily. This is not a problem.

1. Run the engine at low idle for approximately 5 minutes to cool down the engine gradually.
2. Turn the key in starting switch (1) to OFF position (A), and stop the engine.

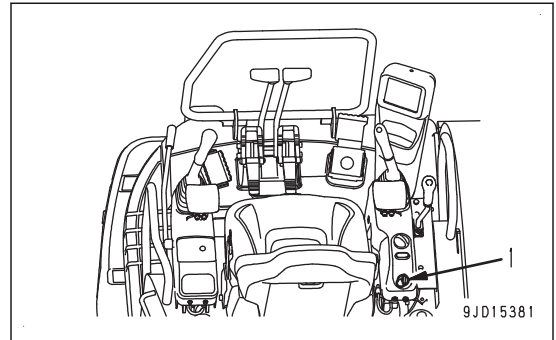

3. Remove the key from the starting switch (1).

REMARK

When the key in starting switch (1) is turned to OFF position (A), the engine stops but the power supply to the machine is not turned off immediately.

The controller terminates the system after recording the operation state of the machine. While this process continues, the main power is maintained.

The time to keep supplying the power depends on the operating condition of the machine.

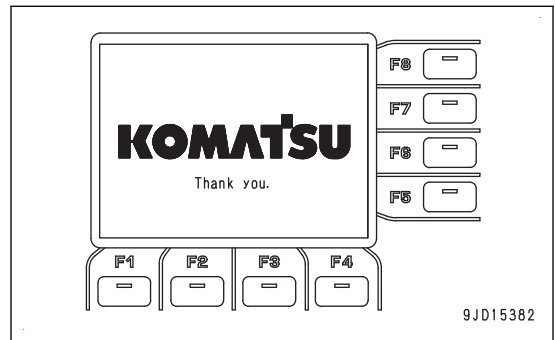
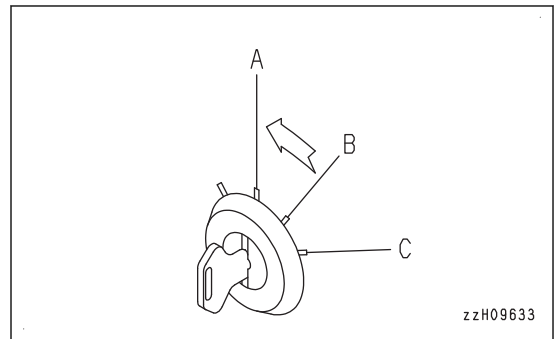

METHOD FOR STARTING MACHINE (TRAVEL FORWARD AND REVERSE) AND STOPPING MACHINE

WARNING

- Check that the direction of the track frame is proper before operating the travel levers or travel pedals.
If the track frame is facing the rear (if the sprocket is at the front), the machine moves in the opposite direction to the direction of the operation of the travel levers or travel pedals (front and rear travel are reversed, right and left steering are reversed).
- Check that the area around the machine is safe, sound the horn before starting the machine.
- Keep people away from the machine.
- Clear any obstacles from the travel path.
- Operate the levers carefully. The engine speed may suddenly increase during the auto-deceleration.
- When traveling, check that the travel alarm sounds normally.

PREPARATIONS FOR MOVING MACHINE

Turn fuel control dial (1) from Low idle (MIN) position (a) to High idle (MAX) position (b).
The engine speed increases.

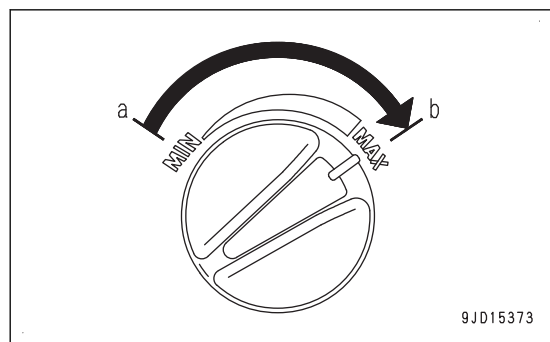
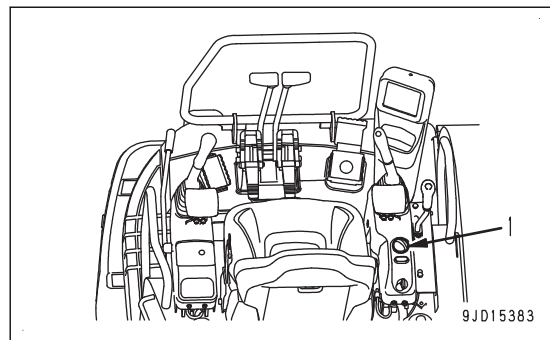

METHOD FOR TRAVELING FORWARD

1. Move the lock lever (1) slowly and securely to FREE position (F).

Be sure to operate the lock lever (1) by the operating portion on the top.

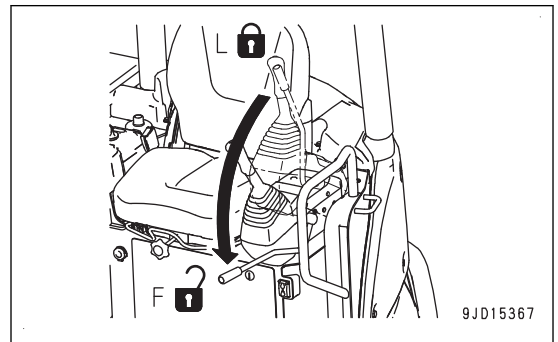
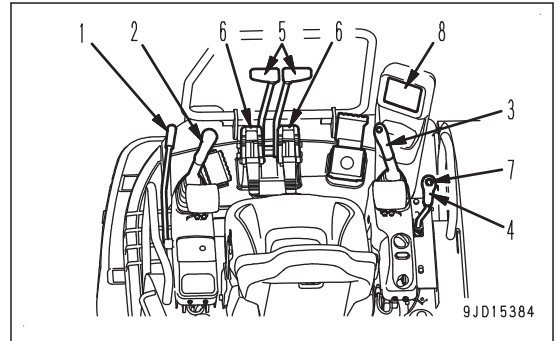

2. Set the machine state in the posture shown in the figure.
 - 1) Operate the R.H. and L.H. work equipment control levers (2) and (3), and raise the work equipment to the height (a) of 40 to 50 cm {15.7 to 19.7 in} .
 - 2) Operate the blade control lever (4) to raise the blade.

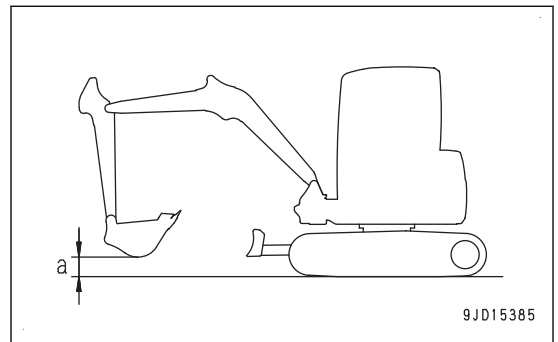

3. Check the sprocket position (A).
4. After checking the sprocket position (A), perform the operation in conformity with the sprocket position. Operate the travel levers (5) or the travel pedals (6) as follows.

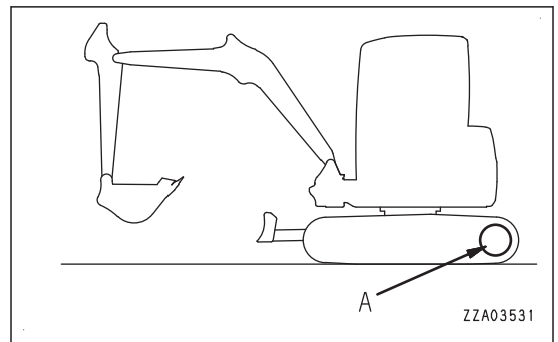

- When the sprocket position (A) is rear of the machine, start the machine either by pushing the travel levers (5) forward slowly or by depressing the front parts of the travel pedals (6) slowly.

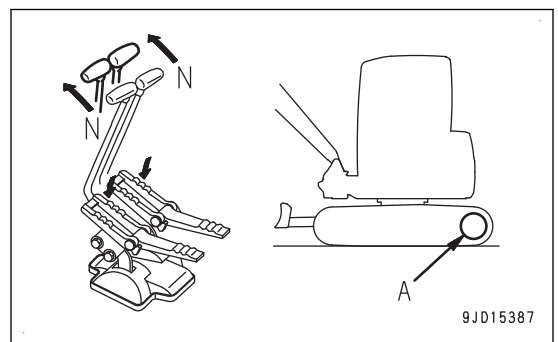

- When the sprocket position (A) is front of the machine, start the machine either by pulling the travel levers (5) backward slowly or by depressing the rear parts of the travel pedals (6) slowly.

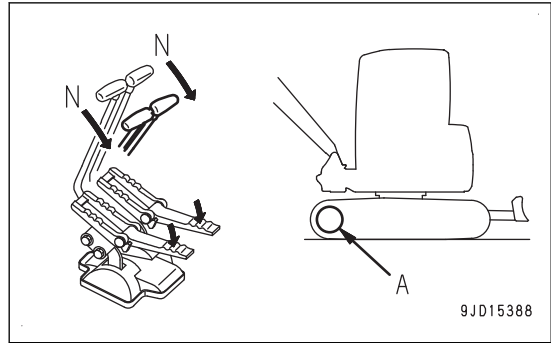

- Push the travel speed selector switch (7) to set the travel speed.

Each time the travel speed selector switch (7) is pressed, travel mode changes repeatedly as Lo → Hi → Lo.

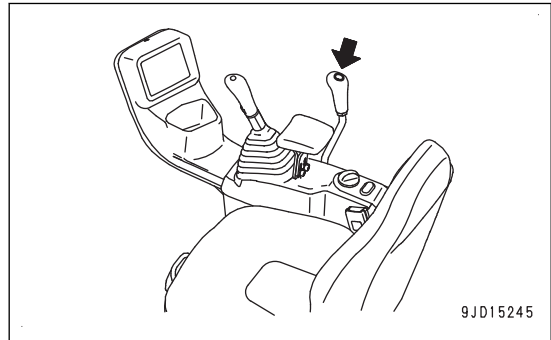

Check the travel mode setting at travel speed display on machine monitor (8).

REMARK

When the engine is started, the speed mode is automatically set to low-speed travel (Lo). While traveling in high-speed travel (Hi), if the traction force is needed in soft ground or on a slope, travel speed automatically changes to low-speed travel (Lo), although high-speed travel (Hi) is lit in travel speed display.

- When traveling, check that the travel alarm sounds normally.

If the alarm does not sound, ask your Komatsu distributor for repair.

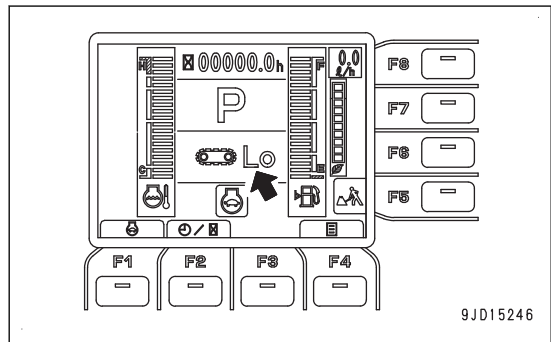

METHOD FOR TRAVELING REVERSE

1. Move the lock lever (1) slowly and securely to FREE position (F).

Be sure to operate the lock lever (1) by the operating portion on the top.

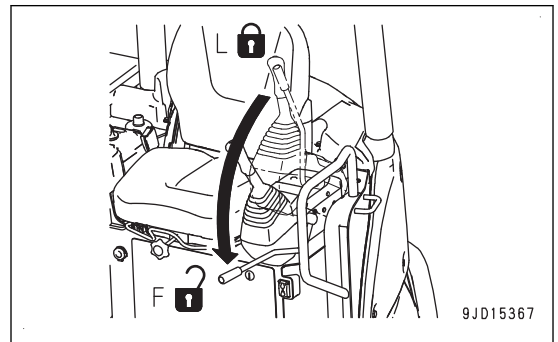
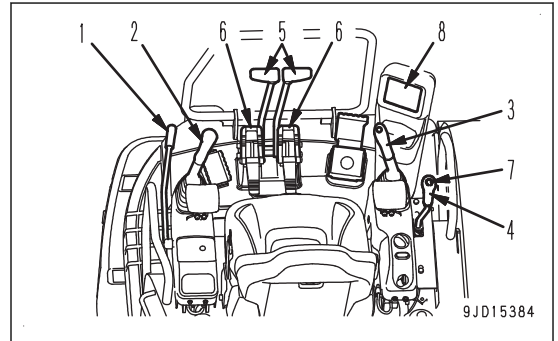

2. Set the machine state in the posture shown in the figure.
 - 1) Operate the R.H. and L.H. work equipment control levers (2) and (3), and raise the work equipment to the height (a) of 40 to 50 cm {15.7 to 19.7 in} .
 - 2) Operate the blade control lever (4) to raise the blade.

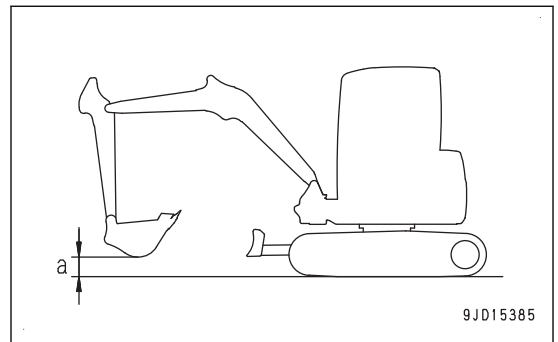

3. Check the sprocket position (A).
4. After checking the sprocket position (A), perform the operation in conformity with the sprocket position.
Operate the travel levers (5) or the travel pedals (6) as follows.

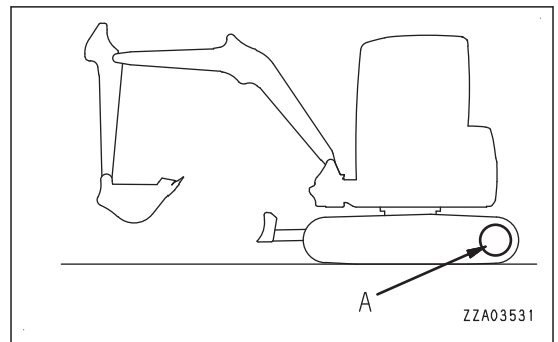

- When the sprocket position (A) is rear of the machine, start the machine either by pulling the travel levers (5) backward slowly or by depressing the rear parts of the R.H. and L.H. travel pedals (6) slowly.

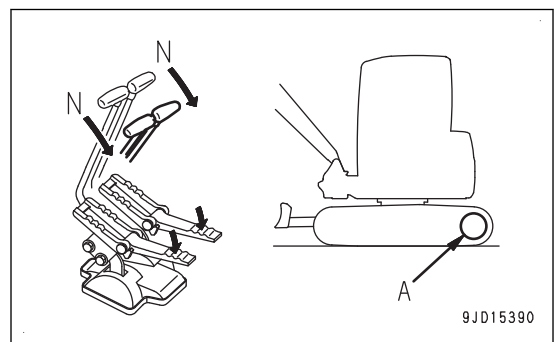

- When the sprocket position (A) is front of the machine, start the machine either by pushing the travel levers (5) forward slowly or by depressing the front parts of the travel pedals (6) slowly.

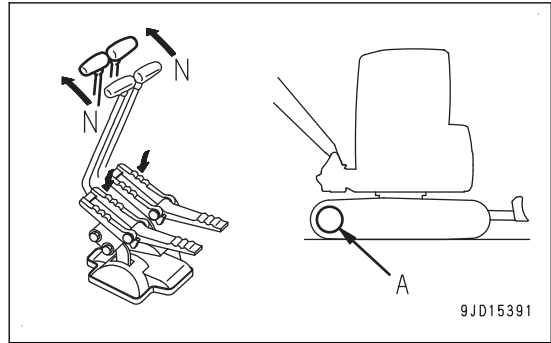

- Push the travel speed selector switch (7) to set the travel speed.

Each time the travel speed selector switch (7) is pressed, travel mode changes repeatedly as Lo → Hi → Lo.

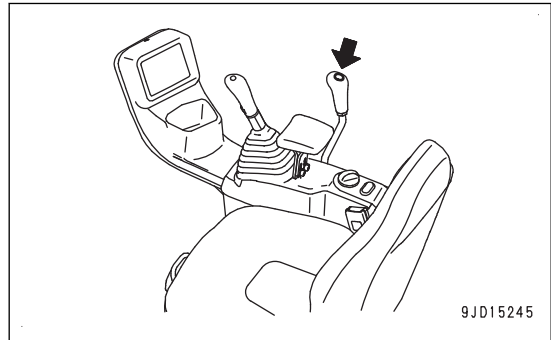

Check the travel mode setting at travel speed display on machine monitor (8).

REMARK

When the engine is started, the speed mode is automatically set to low-speed travel (Lo). While traveling in high-speed travel (Hi), if the traction force is needed in soft ground or on a slope, travel speed automatically changes to low-speed travel (Lo), although high-speed travel (Hi) is lit in travel speed display.

- When traveling, check that the travel alarm sounds normally.

If the alarm does not sound, ask your Komatsu distributor for repair.

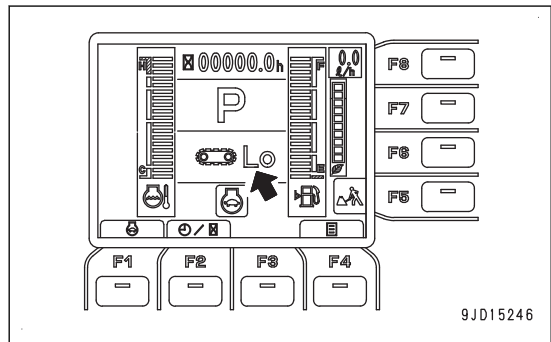

METHOD FOR STOPPING MACHINE

Avoid a sudden stop. Stop the machine gradually.

Set right and left travel levers (1) in NEUTRAL position (N).

The machine stops.

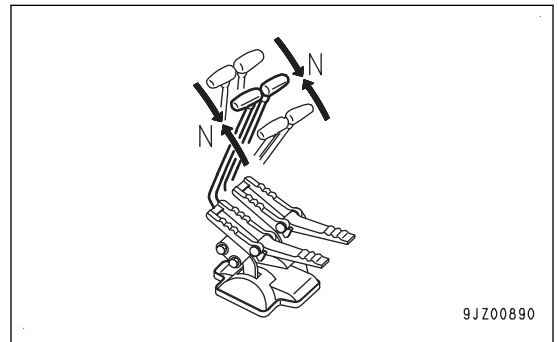
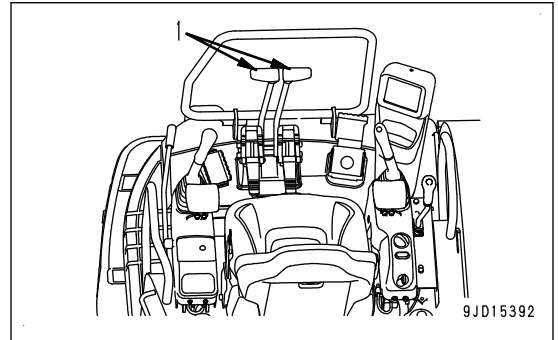

METHOD FOR STEERING MACHINE

METHOD FOR STEERING (CHANGE THE DIRECTION) MACHINE

! WARNING

Before operating the travel levers or travel pedals, check the direction that the track frame is facing (the position of the sprocket).

When the sprocket is at the front, the directions of operations of the travel levers or travel pedals are the opposite to the direction of movement of the machine.

REMARK

When turning while traveling at high speed, if the load is large, the automatic travel mode change function actuates and the travel mode automatically turns to Lo and travel speed becomes slow.

When the load decreases, the travel mode turns to Hi again.

Use 2 travel levers (1) or travel pedals (2) to change direction to travel.

Avoid sudden changes of direction to travel as much as possible. Especially when performing counter-rotation turn (spin turn), stop the machine before turning.

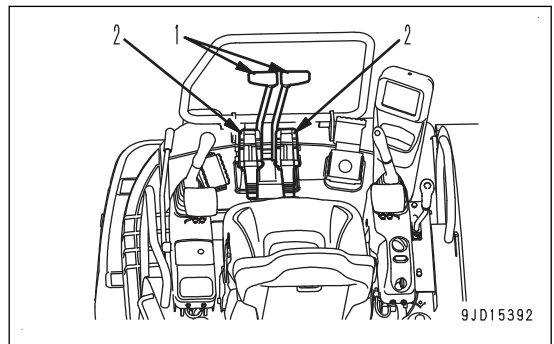

OPERATION TO CHANGE DIRECTION OF STOPPED MACHINE

When turning left

(A) Left turn in forward

Push the right travel lever forward.

The machine turns left in forward.

(B) Left turn in reverse

Pull the right travel lever backward.

The machine turns left in reverse.

REMARK

When turning right, read the preceding procedure by replacing the word "left" with "right", then operate the left travel lever.

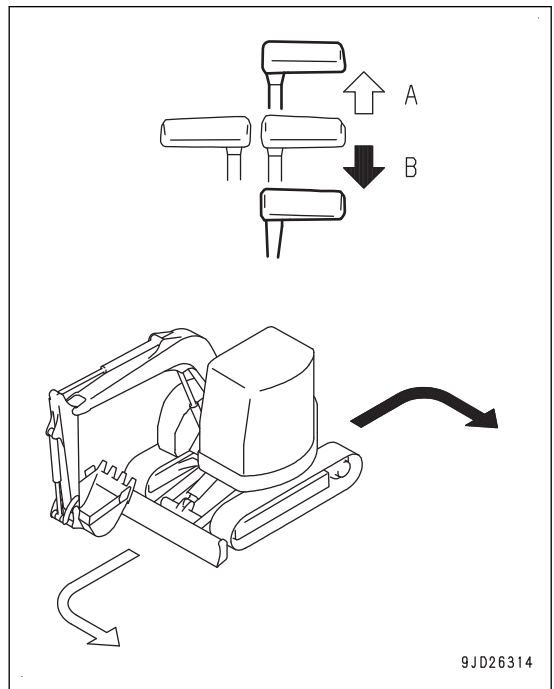

CHANGE DIRECTION OF MACHINE

When turning left

(A) Forward left turn

Return the left travel lever from FORWARD to NEUTRAL position.

The machine turns left in forward.

(B) Reverse left turn

Return the left travel lever from REVERSE to NEUTRAL position.

The machine turns left in reverse.

REMARK

When turning right, read the preceding procedure by replacing the word "left" with "right", then operate the right travel lever.

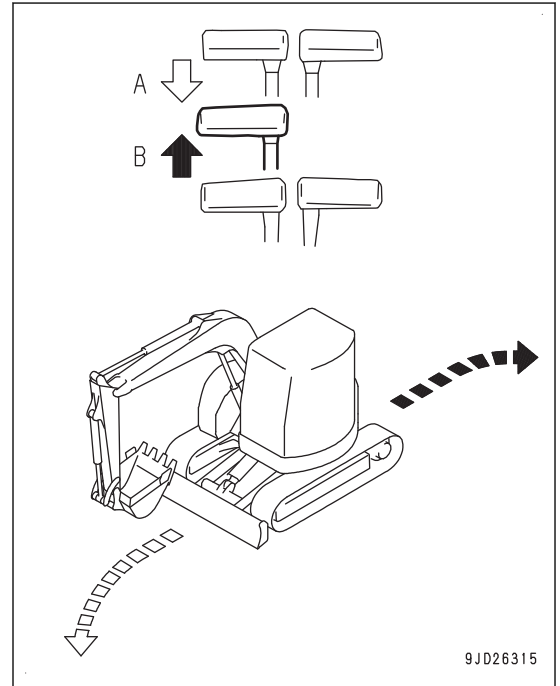

OPERATION FOR COUNTER-ROTATION TURN

- Counter-rotation turn to left
 1. Pull the left travel lever toward you.
 2. Push the right travel lever forward.

The machine make a counter-rotation turn to the left.

- Counter-rotation turn to right
 1. Pull the right travel lever toward you.
 2. Push the left travel lever forward.

The machine make a counter-rotation turn to the right.

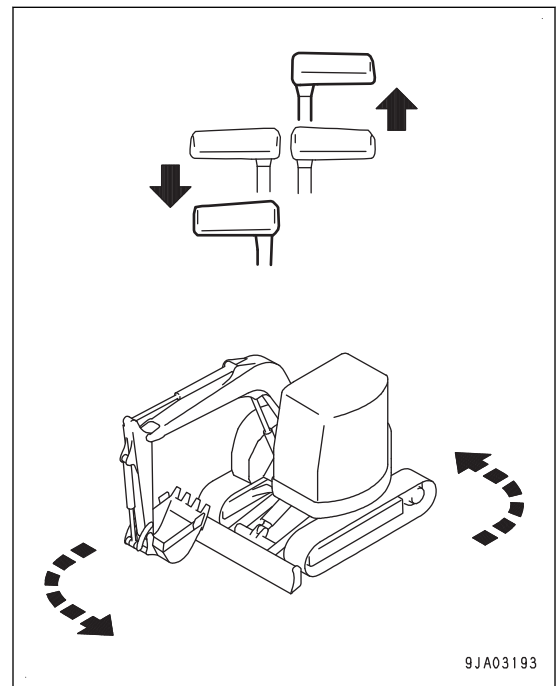

METHOD FOR SWINGING MACHINE

⚠ WARNING

- The tail of the machine extends outside the tracks. Visually check safety around the machine before swinging.
- When performing swing operation on a slope, the machine may lose its balance and turn over. Avoid such operation as much as possible. It is particularly dangerous to swing downhill when the bucket is loaded. If it is unavoidable to perform such operations, prepare an embankment to make a platform (A) on the slope so that the machine is horizontal.

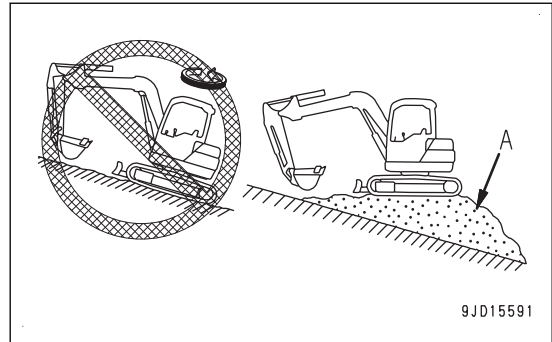

Move L.H. work equipment control lever (1) to the right and left. The upper structure swings.

(a) Swing RIGHT

The upper structure swings to the right.

(b) Swing LEFT

The upper structure swings to the left.

When you do not swing the upper structure, set L.H. work equipment control lever (1) to NEUTRAL position (N).

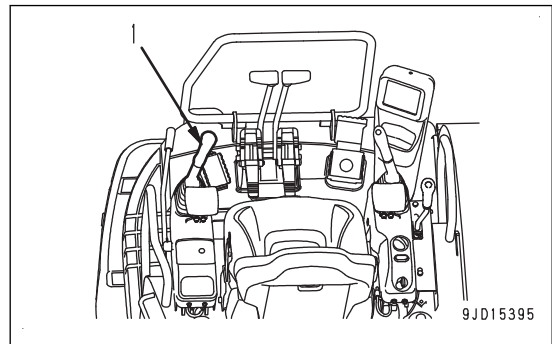

REMARK

To swing upper structure on a slope, run the engine at low idle and operate the work equipment control lever finely. In particular, avoid the abrupt operation when bucket is loaded. When bucket is loaded, the swing parking brake is released and upper structure swings momentarily by operating the L.H. work equipment control lever, but it is not a trouble.

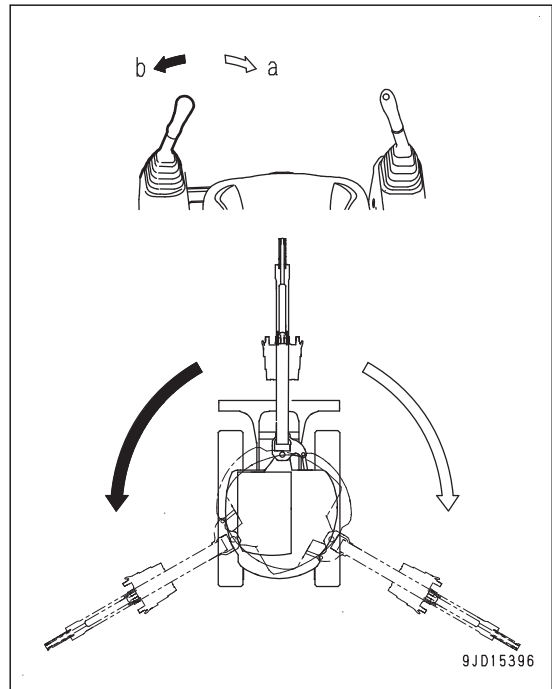

METHOD FOR OPERATING WORK EQUIPMENT

WARNING

For control patterns other than the standard control method (ISO pattern), see ATTACHMENTS AND OPTIONS.

Use the control levers to operate the work equipment.

When the levers are released, they return to NEUTRAL position and the work equipment is held in that position.

- Arm operation
Move the L.H. work equipment control lever back and forth.
Arm moves in or out.

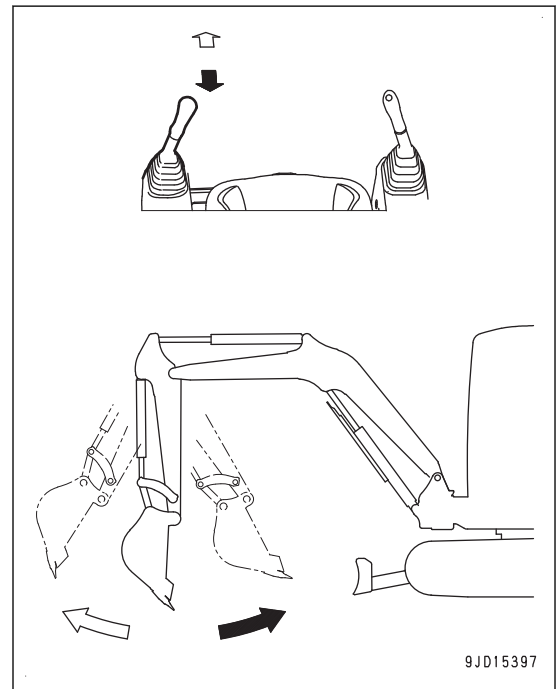

- Boom operation
Move the R.H. work equipment control lever back and forth.
Boom moves up or down.

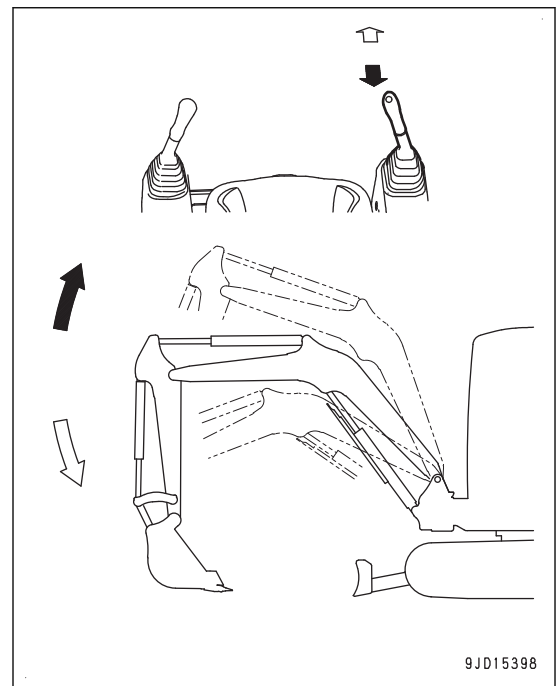

- Bucket operation

Move the R.H. work equipment control lever to the right and left.

Bucket moves in or out.

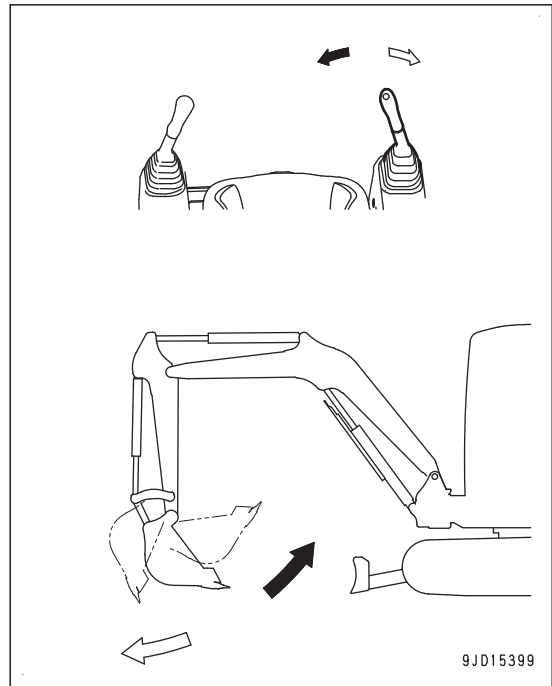

- Boom swing operation

Depress either right or left of the Boom swing control pedal.

Boom swings either right or left.

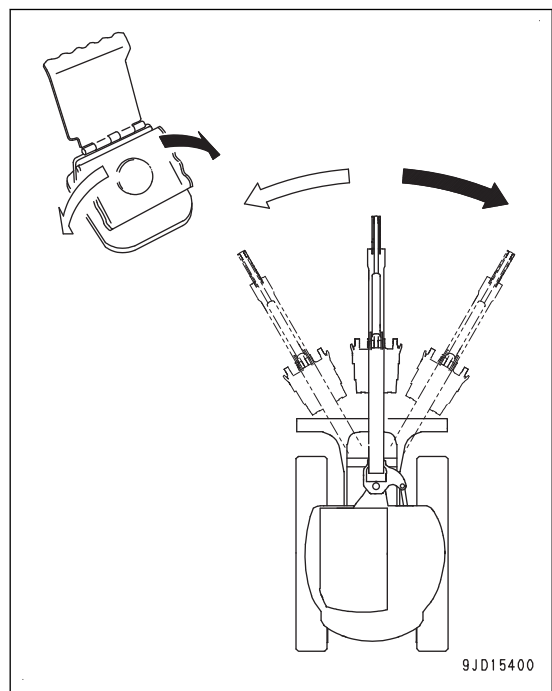

- Blade operation
Move the blade control lever back and forth.
Blade moves up or down.

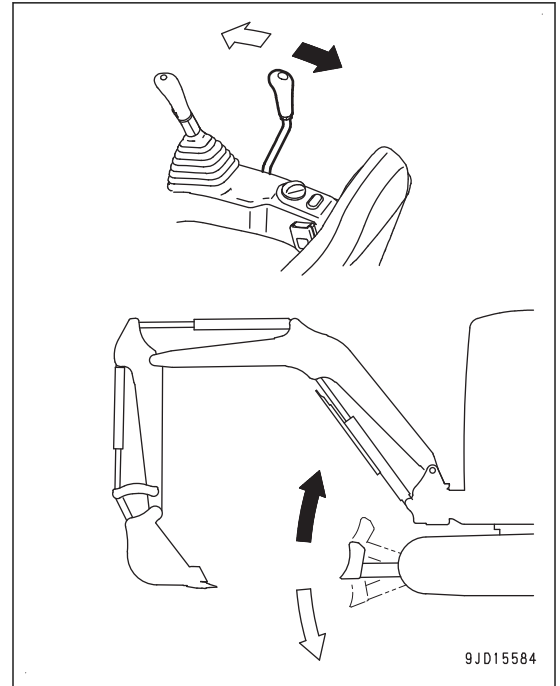
**REMARK**

This machine is equipped with an accumulator in the control circuit. For some time after stopping the engine, even if the engine is stopped, if the starting switch key is turned to ON position, and the lock lever is set to FREE position, following work equipment operations are possible.

- Lower the work equipment to the ground.
- The remaining pressure in hydraulic cylinder circuit can be removed by operating the work equipment.
- Lower the boom after loading the machine to the trailer.

HANDLE WORKING MODE

NOTICE

Do not perform breaker operations in any mode other than the breaker mode. Otherwise, the breakage of hydraulic component will occur.

Select the working mode that matches the operating conditions or purpose. This will make it possible to perform operations efficiently.

When the starting switch is turned to ON position, the working mode is set to the mode when key was in OFF position.

Set the most efficient mode to match the type of work.

Working mode	Applicable operations
P mode	Normal digging or loading operations (production conscious operation)
E mode	Normal digging or loading operations (fuel consumption conscious operation)
B mode	Breaker operation
ATT/P mode	Operations of 2-way attachment such as crusher, etc. (production conscious operation)
ATT/E mode	Operations of 2-way attachment such as crusher, etc. (fuel consumption conscious operation)

METHOD FOR OPERATING WORKING MODE

1. Press function switch "F5" on the standard screen of machine monitor.

The screen changes to "Working Mode" screen.

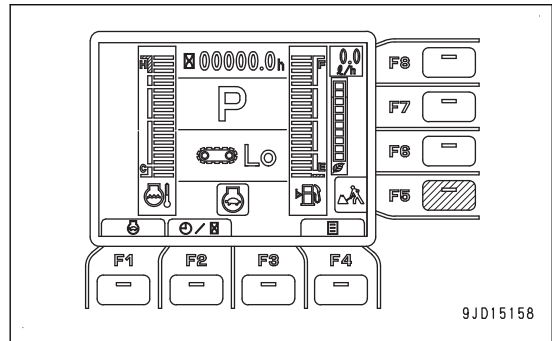

2. On "Working Mode" screen, press function switches "F1", "F2", and "F5" to select the appropriate working mode.
3. After selecting the working mode, press function switch "F4".

Change the setting of selected working mode, and then the screen returns to the standard screen.

When function switch "F3" is pressed, the change is canceled and the screen returns to the standard screen.

If a working mode is selected, and nothing is done for 5 seconds, the selected working mode is automatically accepted and the screen returns to the standard screen.

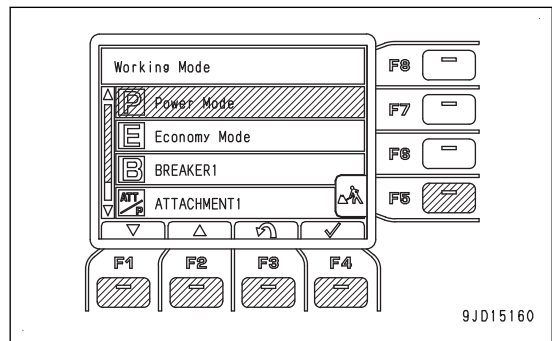

PROHIBITED OPERATIONS

WARNING

Do not operate the work equipment control lever when the machine is traveling.

PROHIBITION OF OPERATIONS USING SWING FORCE

Do not use the swing force to compact soil or break objects. It drastically reduces the life of the machine, and is also dangerous.

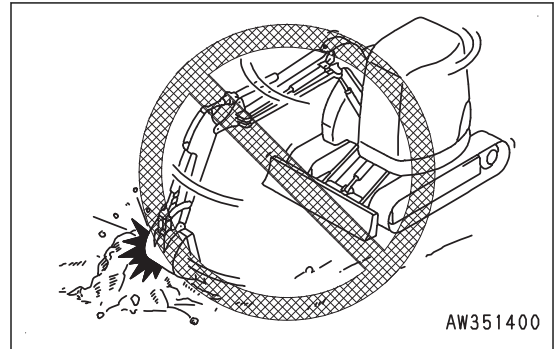

PROHIBITION OF OPERATIONS USING TRAVEL FORCE

Do not use the travel force to perform excavation by digging the bucket into the ground. This damages the machine or work equipment.

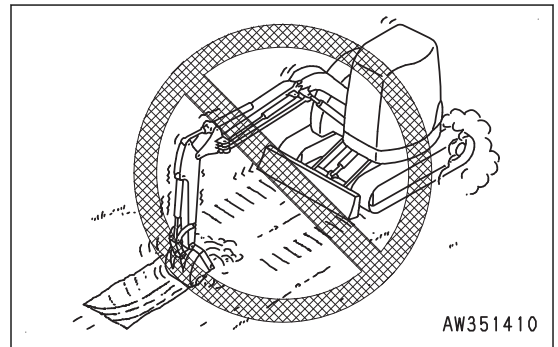

PROHIBITION OF OPERATIONS USING HYDRAULIC CYLINDERS TO STROKE END

If the work equipment is used with the cylinder rod operated to its stroke end (fully extended or fully retracted), and given impact by some external force, the hydraulic cylinders may be damaged, causing personal injury.

Do not perform operations with the hydraulic cylinder at stroke end.

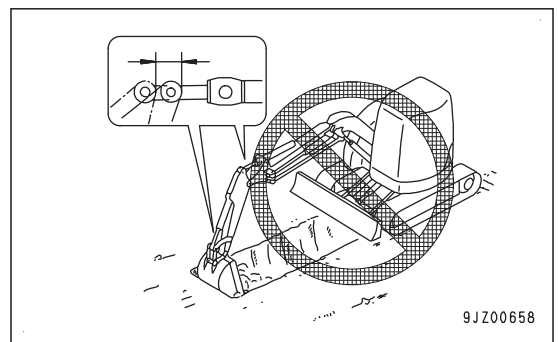

PROHIBITION OF OPERATIONS USING BUCKET DROPPING FORCE

Do not use the dropping force of the machine for digging, nor use the dropping force of the bucket as a mattock, breaker, or pile driver.

This will drastically reduce the life of the machine.

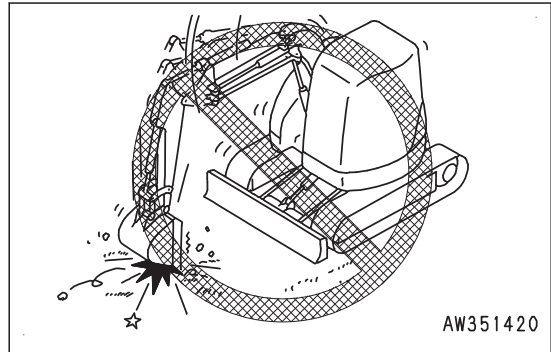

PROHIBITION OF OPERATIONS USING BUCKET AS LEVER

Do not put the bucket back to a rock and use it as a lever to dig.

This can apply an excessive force to the chassis and work equipment, and the machine may break.

As shown in the figure, dig by using only the force of the arm or bucket.

If an excessive force is applied, the safety valve of the hydraulic system controls it into a proper range to prevent breakage of the machine.

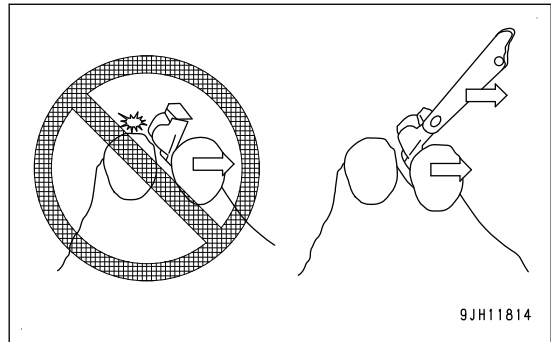

PROHIBITION OF OPERATIONS USING MACHINE DROPPING FORCE

Do not use the dropping force of the machine for digging.

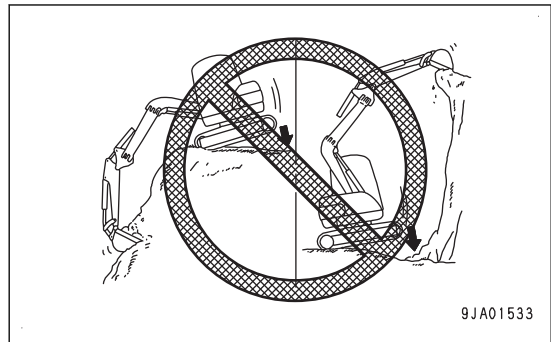

PROHIBITION OF DIGGING OPERATION AT AN ANGLE WITHOUT ENGAGING TEETH

If the machine swings and digs simultaneously while the bucket blade does not bite into hard rocks at a position higher than the machine, the teeth slide down on the rock surfaces. As a result, large vibration occurs in the machine and can crack the work equipment or frame.

If the bucket blade slides and collides with a rock, an excessive impact load occurs in the work equipment and frame and can shorten the service life of the machine.

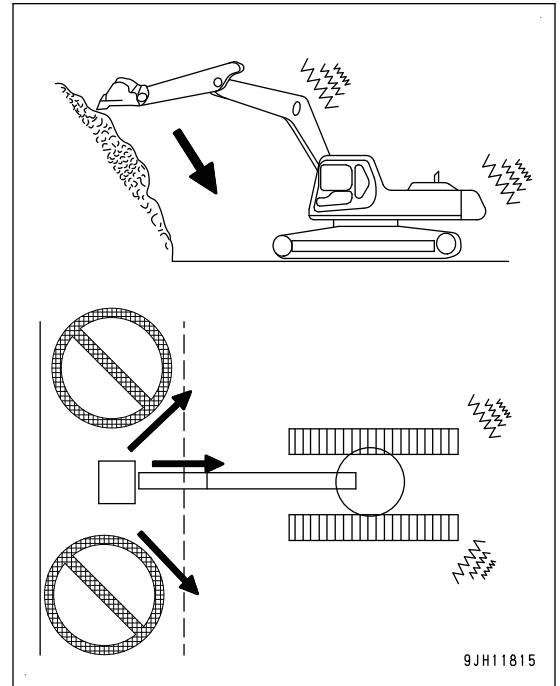

PROHIBITION OF DIGGING OPERATION ON HARD ROCKY GROUND

Do not attempt to directly excavate hard rocky ground with the work equipment. It is better to excavate it after breaking up by some other means. This will not only save the machine from damage but will make for better economy.

PROHIBITION OF OPERATIONS WHEN MACHINE IS NOT STABLE

If the machine is operated while its undercarriage is unstable, torsional loads occur in the frames and can shorten the service life of the machine.

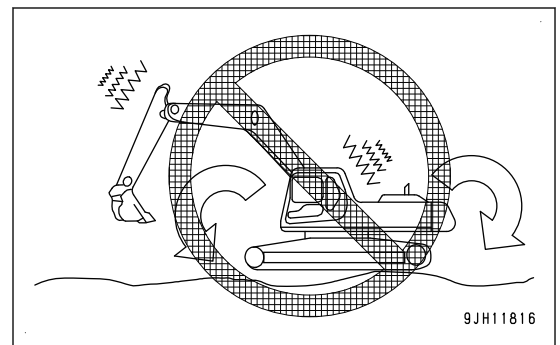

In this case, prepare an embankment, etc. in front of the track to stabilize the machine.

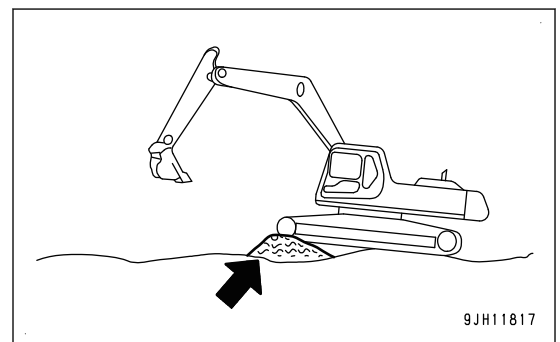

PROHIBITION OF SWINGING OR TRAVELING WHEN ROCK IS ON TOP OF TRACK ASSEMBLY

If the machine travels or swings with crushed stones, soil, or sand on the track, they hit and damage the undercover and frame. In the worst case, the hydraulic components are damaged and a serious accident can result.

During operation, keep checking the track top for crushed stones, soil, and sand.

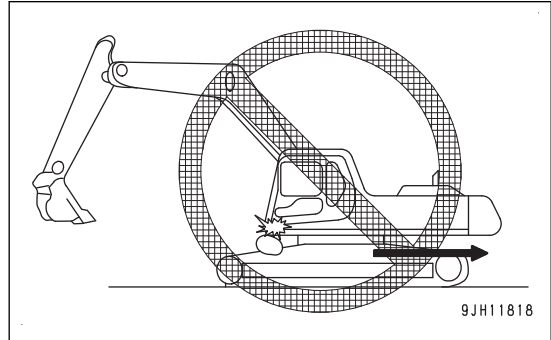

DO NOT PERFORM LIFTING OPERATIONS

Although lifting operation with this machine is prohibited, it is permitted only when the special lifting hook is installed.

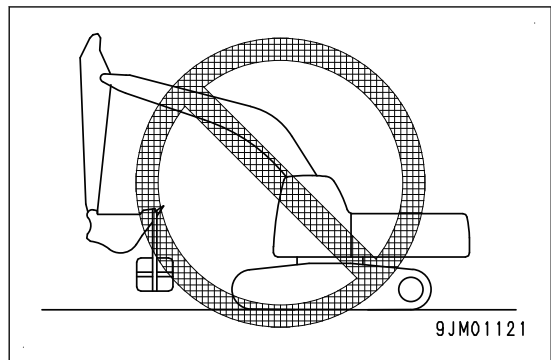

PROHIBITION OF SUDDEN LEVER OR PEDAL SHIFT DURING HIGH SPEED TRAVEL

- (1) Do not operate the levers and pedals suddenly nor take any other action to move the machine quickly.
- (2) Do not operate the levers or pedals suddenly from FORWARD (A) to REVERSE (B) (or from REVERSE (B) to FORWARD (A)).
- (3) Do not operate the levers or pedals suddenly (do not release them suddenly) to stop the machine when driving it at high speed.

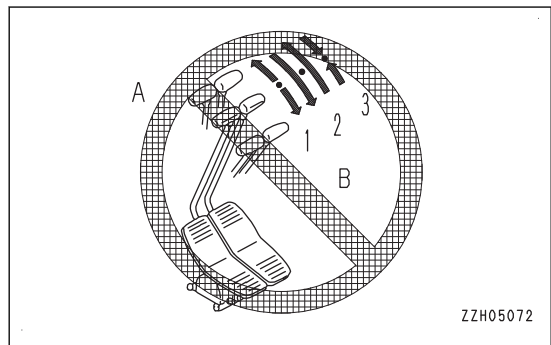

PROHIBITION OF HIGH-SPEED TRAVEL OPERATIONS ON ROUGH GROUND

If the machine travels on rough ground (rock-bed, etc.) at high speed, large push-up loads are applied to the chassis, thus the service life of the chassis is shortened.

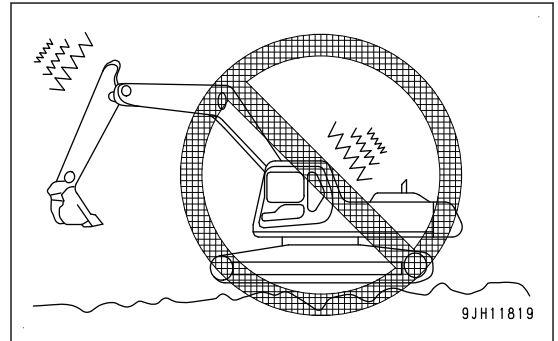

When driving on rough ground (rock-bed, etc.), direct the idler (1) having the cushion mechanism in the travel direction and drive the machine at low speed.

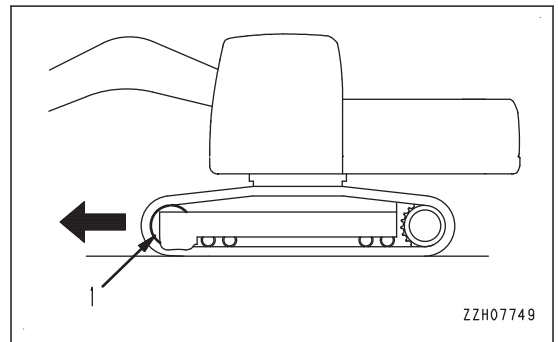

GROUND WHOLE THE BOTTOM SIDE OF BLADE TO SUPPORT MACHINE

When using the blade as an outrigger, never support the machine with only one end of the blade.

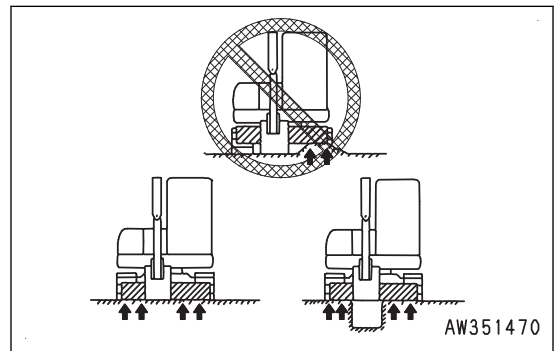

DO NOT TRAVEL LONG -TIME CONTINUOUSLY

If the machine travels continuously at high speed for 1.5 hours or more, the temperature of lubricating oil inside the track rollers and final drive will rise up, and oil seal may be damaged to cause oil leakage.

Stop driving for 30 minutes every 1.5 hours to cool the lubricating oil inside the track rollers and final drives when driving the machine continuously for a long time.

If the machine travels continuously for a long time with the tracks loosened, the undercarriage parts may be broken prematurely.

Check the track tension every 1.5 hours, and adjust any looseness when driving the machine for a long time.

For the adjustment, see MAINTENANCE, "METHOD FOR CHECKING AND ADJUSTING STEEL SHOES AND ROADLINERS TRACK TENSION" and "METHOD FOR CHECKING AND ADJUSTING RUBBER SHOES TRACK TENSION".

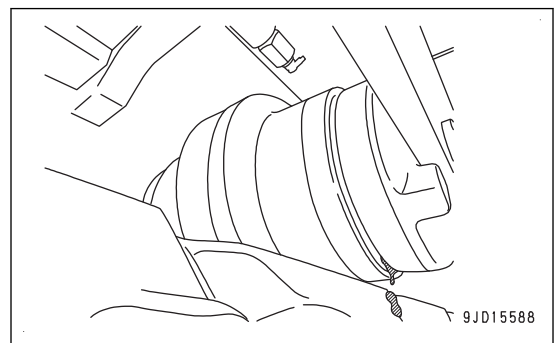

PRECAUTIONS FOR OPERATION

PRECAUTIONS FOR TRAVELING

Traveling over boulders, tree stumps, or other obstacles will cause a big shock to the chassis (and in particular to the undercarriage), and this will cause damage to the machine. For this reason, always remove any obstacles or drive the machine around them, or take other steps to avoid traveling over such obstacles as far as possible.

If there is no way to avoid traveling over an obstacle, reduce the travel speed, keep the work equipment close to the ground, and try to drive the machine so that the center of the track passes over the obstacle.

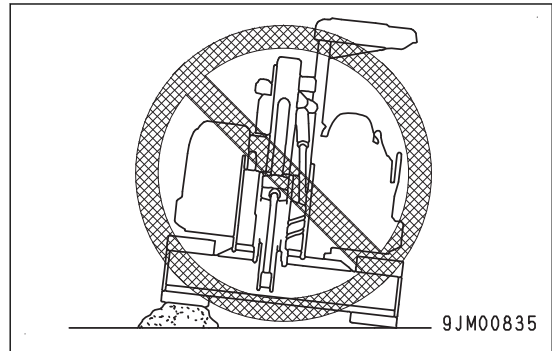

PRECAUTIONS FOR HIGH SPEED TRAVEL

On uneven roadbeds such as rock beds or uneven roads with large rocks, drive the machine with travel mode at Lo.

When driving the machine with travel mode at Hi, set the idler in the forward direction.

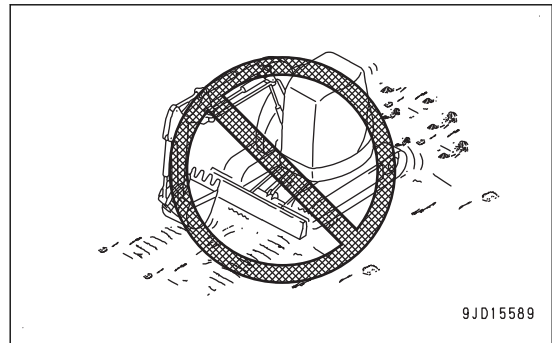

PRECAUTIONS FOR FOLDING WORK EQUIPMENT

When folding in the work equipment to the travel or transportation posture, be careful not to let the bucket hit the blade.

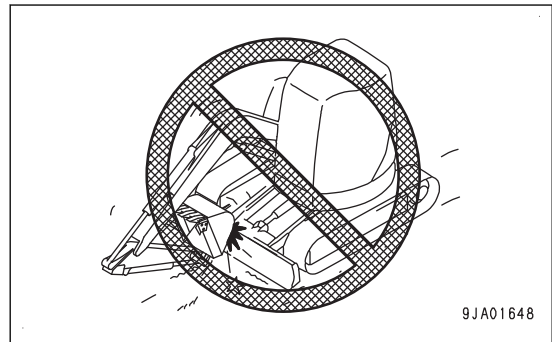

PRECAUTIONS FOR HITTING BLADE AGAINST OBJECTS DURING OPERATING BLADE

Be careful not to hit the blade against rocks or boulders. This will cause premature damage to the blade or cylinders.

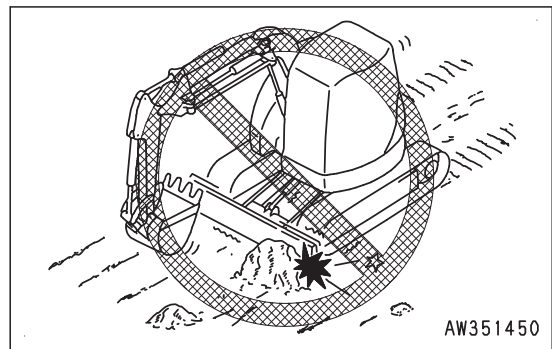

PRECAUTIONS FOR BLADE POSITION DURING BACKHOE OPERATION

When performing the backhoe operation near the blade, take care that the boom cylinder does not touch the blade. Dig with the blade at the rear usually, and dig in front of the blade only when required.

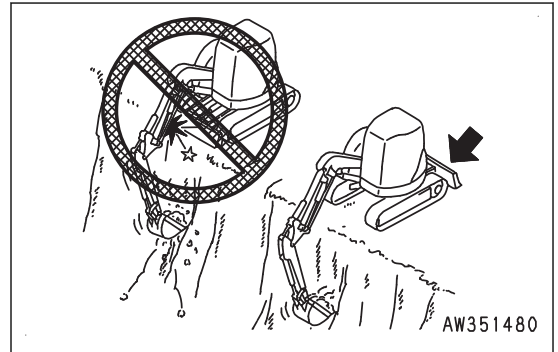

PRECAUTIONS FOR OPENING AND CLOSING COVERS

Close all the covers and lock the lockable covers when operating or driving the machine.

If you operate the machine with the cover open, it may hit something around it and break.

If you operate or drive the machine with cover unlocked, it may open and hit surrounding object to lead accident.

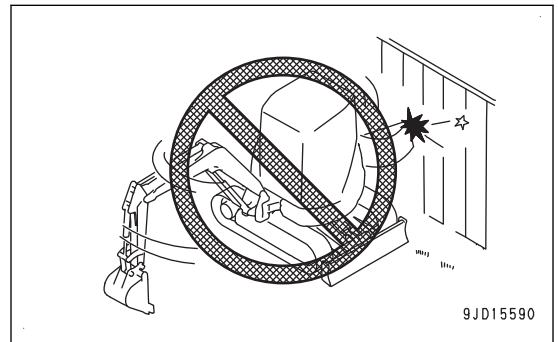

PERMISSIBLE DEPTH OF WATER, SOIL AND DIRT

NOTICE

When traveling the machine out of water, if the angle of the machine exceeds 15° , the rear of the upper structure will go under water, and water will be thrown up by the radiator fan. This may cause the fan to break. Be extremely careful when driving the machine out of water.

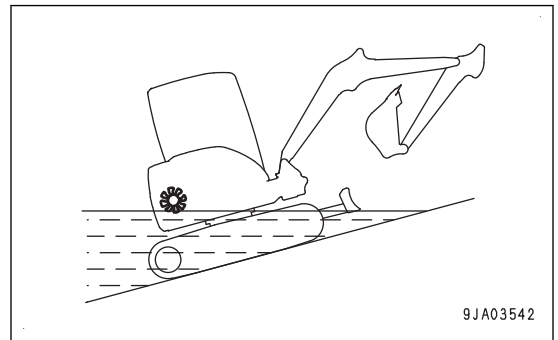

Do not drive the machine in water or soil and dirt deeper than the center of carrier roller (1).

After the job, be sure to supply grease to the parts which have been under water for a long time until the used grease is projected. (Around the bucket pin, in particular)

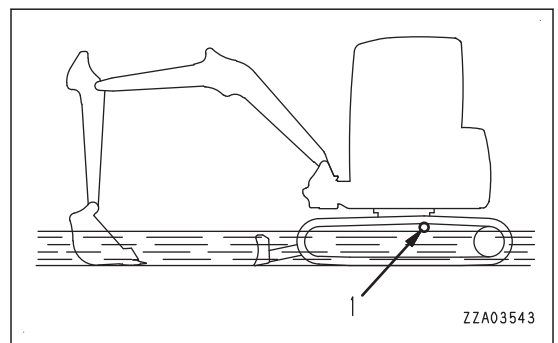

PRECAUTIONS FOR WORKING ON SLOPE

⚠ WARNING

- When performing the swing operation or operating the work equipment on slopes, machine may lose its balance and tip over. Avoid such operations as much as possible.
It is particularly dangerous to swing downhill when the bucket is loaded.
If it is unavoidable to perform such operations, prepare an embankment to make a platform (A) on the slope so that the machine is horizontal.
- Do not operate or drive the machine on a slope covered with the steel plates.
Even with slight slopes, there is a hazard that the machine may slip.
- Do not drive the machine up or down on steep slopes. There is a danger that the machine may turn over.
- When driving the machine, raise the bucket approximately 20 to 30 cm {7.9 to 11.8 in} above the ground.
- Do not drive down in reverse on a slope.
- Never turn on slopes or drive across slopes.
Go down to a flat place once, and take a safer way such as a detour.
- Stay alert while driving and operating the machine in order to stop it safely when the machine slips or becomes unstable.
- When the machine is traveling uphill, if the shoes slip or it is impossible to travel uphill using only the force of the tracks, do not use the pulling force of the arm to help the machine travel uphill.
There is a danger that the machine may tip over.
- Never perform swing operation on a slope even if the engine is stopped. If swing operation is performed with the work equipment control lever, the upper structure may swing under its own weight.
- Do not open or close the door (Machine with cab specification) when the machine is on a slope.
The operating effort may suddenly change.
Always check that the door (Machine with cab specification) is locked either at the open position or closed position.

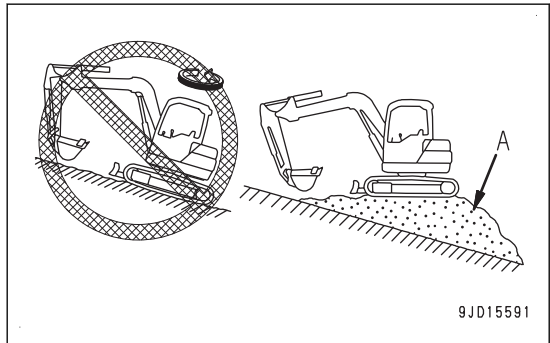
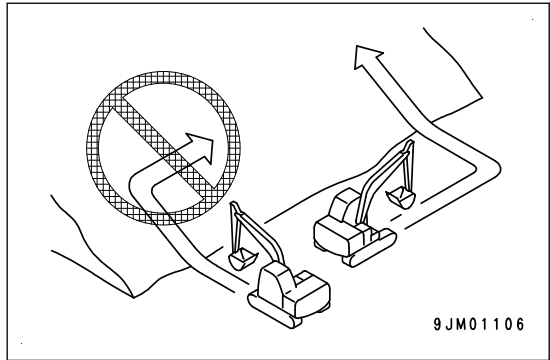

1. When driving the machine down steep hills, use the travel lever and fuel control dial to keep the travel speed low.
When driving the machine down steep hills of 15° or more, set the machine to the posture shown in the figure with sprocket (1) downward, bucket height (a) at 20 to 30 cm {7.9 to 11.8 in} , and lower the engine speed.

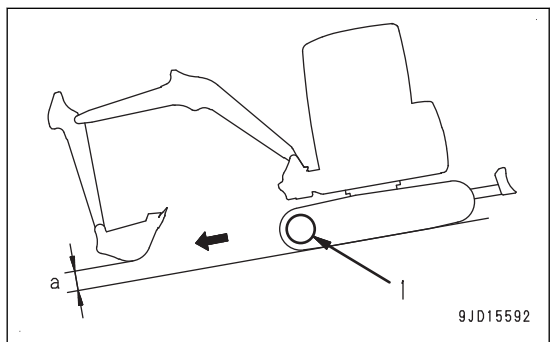

REMARK

Drive the machine down with sprocket (1) downward.
If the machine travels down with sprocket (1) upward, the tracks may be loosened and may jump teeth.

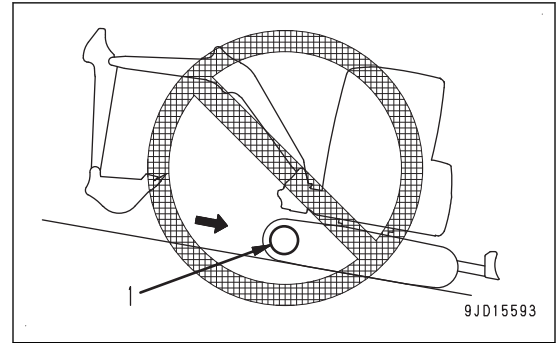

2. When driving the machine up steep hills of 15° or more, set the machine to the posture shown in the figure with bucket height (b) at 20 to 30 cm {7.9 to 11.8 in}, and drive the machine.

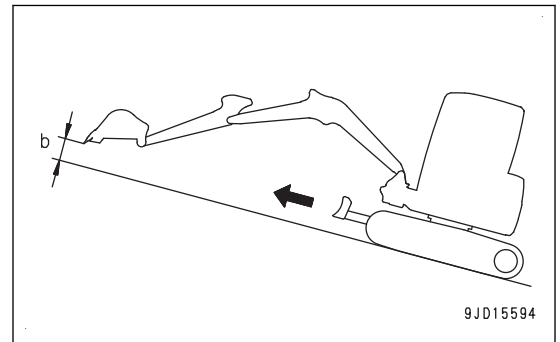
**Braking on downhill slope**

Set the travel lever in NEUTRAL position and the brake will be applied.

If engine stops

If the engine stops when driving the machine uphill, move the travel levers to NEUTRAL position, lower the bucket to the ground, stop the machine, and then start the engine again.

METHOD FOR ESCAPING FROM MUD

Always operate carefully to avoid getting stuck in mud. If the machine does get stuck in mud, do as follows to get the machine out.

METHOD FOR ESCAPING WHEN TRACK ON ONE SIDE IS STUCK

NOTICE

Use the bottom of bucket to push the ground. Operate the boom or arm to raise the machine. (Do not raise with the teeth in contact with the ground)

At this time, set angle (a) between the boom and arm to 90 to 110 °.

When the track on either side gets stuck, pull out the machine according to the following procedure.

1. Move the bucket to the side of the stuck track and press the ground with it.
The track is raised.
2. Place logs, wooden blocks, etc. under the track.
3. Raise the bucket and escape.

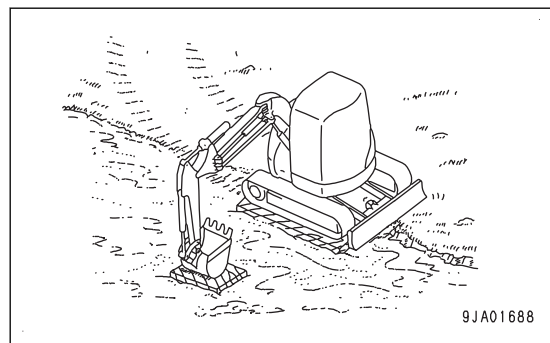
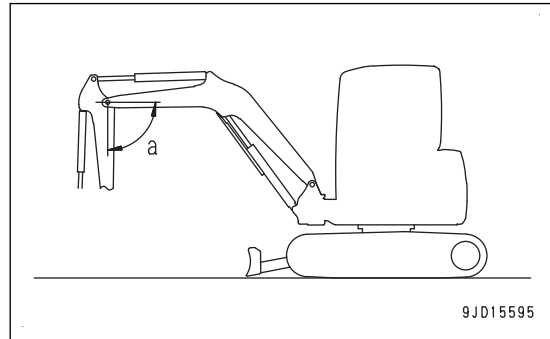

METHOD FOR ESCAPING WHEN TRACKS ON BOTH SIDES ARE STUCK

When the tracks on both sides get stuck, pull out the machine according to the following procedure.

1. Place logs, wooden blocks, etc. under the tracks according to the above procedure.
2. Thrust the bucket into the front ground.
3. Move the arm IN as in digging work and set the travel lever to FORWARD to pull out the machine.

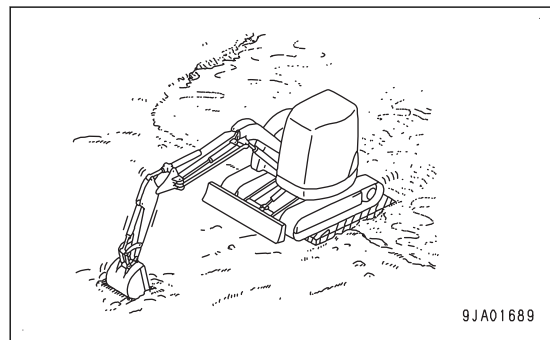

RECOMMENDED APPLICATIONS

In addition to the following, it is possible to further increase the range of applications by using various attachments.

DIGGING WORK

BACKHOE WORK

It is suitable for excavating areas that are lower than the machine.

When the condition of the work equipment is as shown in the figure (angle (a) between bucket cylinder and link, and angle (b) between arm cylinder and arm is 90°), the maximum excavation force is obtained from the pushing force of each cylinder.

When excavating, you can optimize your working efficiency by using this angle effectively.

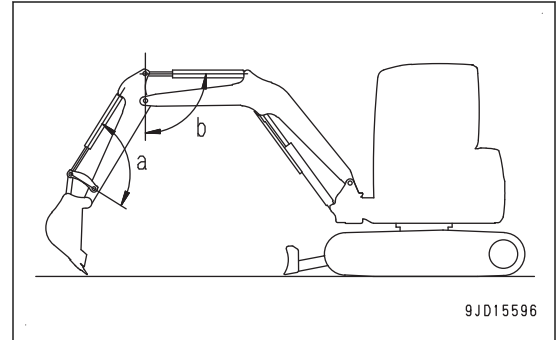

The range for excavating with the arm is from a 45° angle (c) away from the machine to a 30° angle (d) towards the machine.

There may be some differences depending on the excavation depth, but try to stay within the above range rather than operating the cylinder to the end of its stroke.

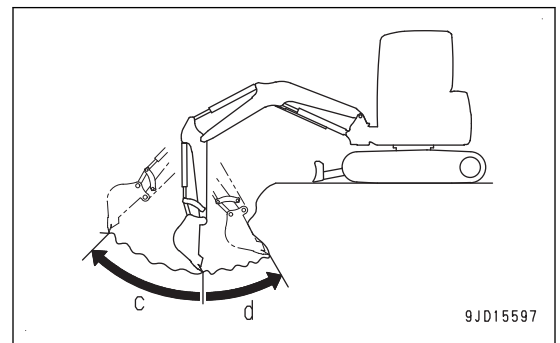

DITCHING WORK

Ditching work can be performed efficiently by attaching a bucket which matches the ditching operation, and then setting the tracks parallel to the line of the ditch to be excavated.

To excavate a wide ditch, first dig both sides and then finally remove the center portion.

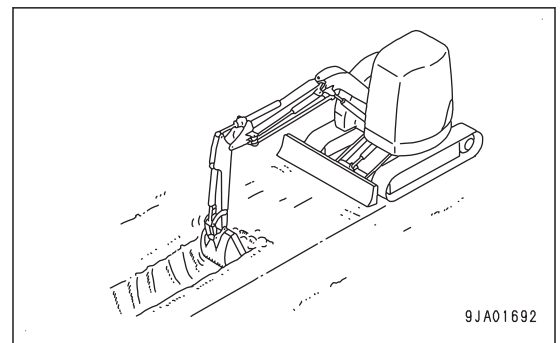

SIDE DITCHING WORK

Ditching work can be performed in a narrow space by combining swing and boom swing operations.

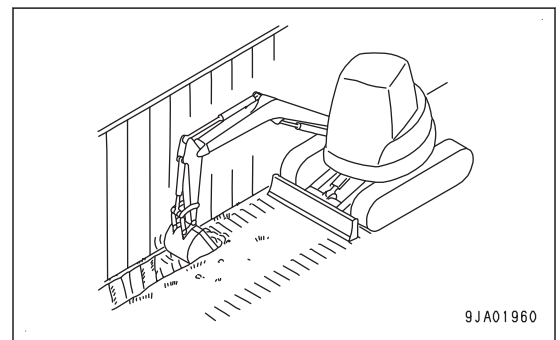

LOADING WORK

In places where the swing angle is small, work efficiency can be enhanced by locating the dump truck in a place easily visible to the operator.

Loading is easier and capacity becomes greater if you place the machine at the rear of the dump truck than if loading is done from the side.

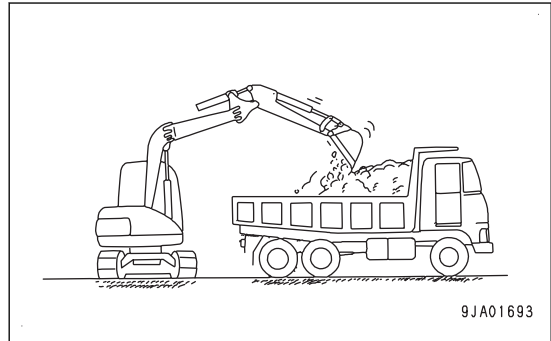

LEVELING WORK

Use the blade for back filling and leveling work after digging the ground.

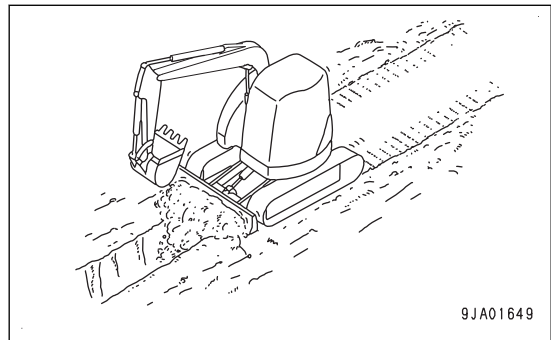

METHOD FOR REPLACING BUCKET

WARNING

- When pins are knocked in with a hammer, pieces of metal may fly and cause serious injury. When performing this operation, always wear protective eyeglasses, helmet, gloves, and other protective equipment.
- Place the removed bucket in a stable condition.
- The pin is hit with a strong force to remove, so the pin may fly out and injure the near people. Pay attention to the area around the machine.
- Do not stand behind the bucket, and do not put your foot on the side of the bucket when removing the pins.
- Do not get your fingers caught when removing or inserting pins.
- Never insert your fingers into the pin holes when aligning the holes.

NOTICE

- After removing the pins, make sure that mud or sand does not get on them.
- Dust seals are fitted at both ends of the bushings, be careful not to damage them. If the dust seal is damaged, replace it with a new one when replacing the bucket. If a damaged seal is used without being replaced, sand and dirt may enter the pin portion and cause abnormal wear of the pin.

Place the machine on a firm and flat surface and do the work.

When performing the joint work, appoint a leader and follow that person's instructions and signals.

1. Set the machine in the posture shown in the figure.

- 1) Start the engine, and run it at low speed.

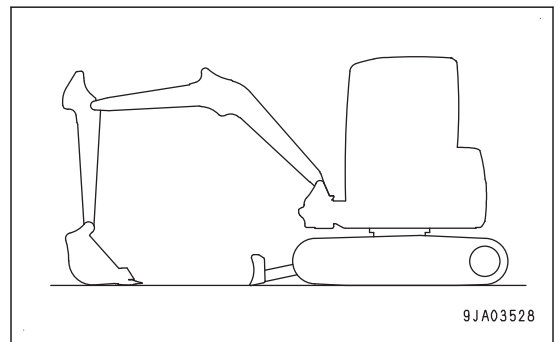

- 2) Set the lock lever to FREE position (F).

Be sure to operate the lock lever by the operating portion on the top.

- 3) Push the blade control lever forward to lower the blade to the ground.
- 4) Operate the work equipment control levers to make the bucket bottom level.
- 5) Operate the work equipment control lever, and lower the boom gently to lower the bucket (1) to the ground.

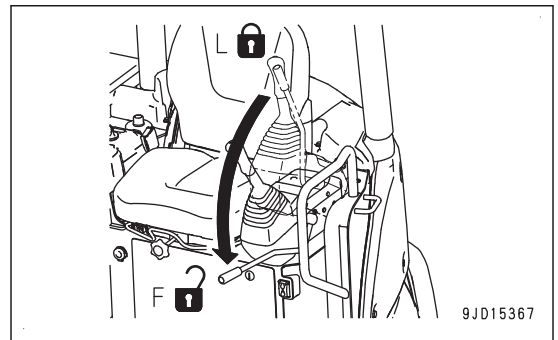

- 6) Set the lock lever to LOCK position (L).
Be sure to operate the lock lever by the operating portion on the top.
- 7) Stop the engine.

REMARK

When removing the pins, place the bucket so that it is in light contact with the ground.
If the bucket contacts strongly to the ground, the resistance at pins will be increased and it will be difficult to remove the pins.

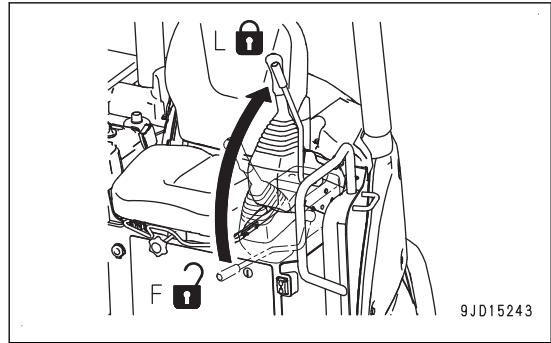

2. Remove the double nut of stopper bolt at arm pin (A) and link pin (B), then pull out the bolts.
3. Pull out the arm pin (A) and link pin (B), then remove the bucket (1).

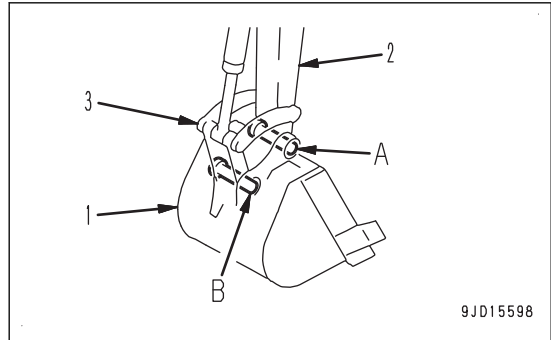

4. Align the arm (2) with hole (4) of the replacement bucket.
5. Align the link (3) with hole (5) of the replacement bucket.
6. Apply grease to pins (A) and (B) and insert them into holes (4) and (5) of the bucket.

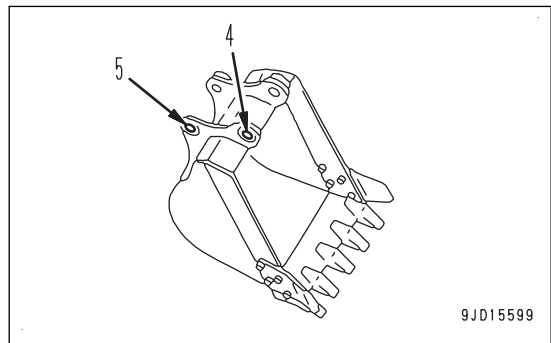

REMARK

- Perform the installation in the reverse order to removal.
- Fit the O-ring (6) to arm (2) as shown in the figure since it is damaged easily when bucket (1) is installed.
After inserting the pin (A) and (B), fit them in the regular groove.

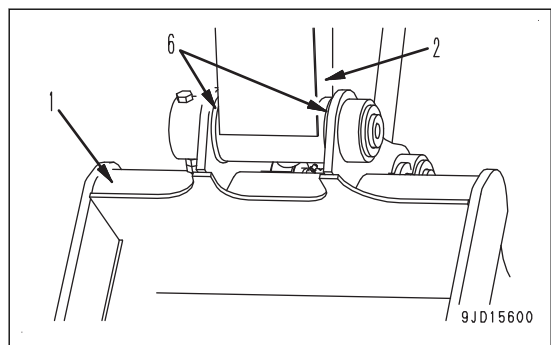

7. Install the lock bolt and nut of each pin.
8. Apply grease to each pin.

REMARK

Lubricate with grease thoroughly from the grease nipple until the grease comes out from the end face of pin.

METHOD FOR PARKING MACHINE

⚠ WARNING

- Avoid a sudden stop. Stop the machine gradually.
- Park the machine on a firm, level ground. Do not park the machine on a slope. Block the tracks from movement if it is unavoidably necessary to park the machine on a slope. As an additional safety measure, thrust the work equipment into the ground.
- The machine may move suddenly if the control lever is touched by accident. This may lead to a serious personal injury or death. Set the lock lever securely to LOCK position always before leaving the operator's seat.
- Lower the blade to the ground on the downhill side.

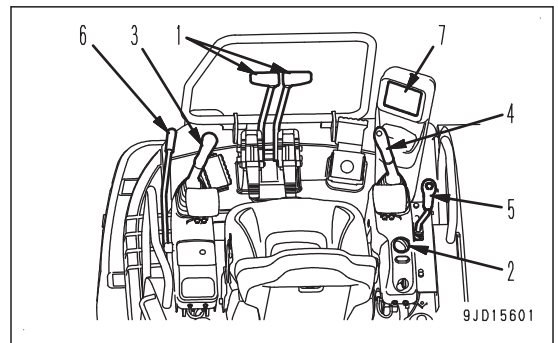
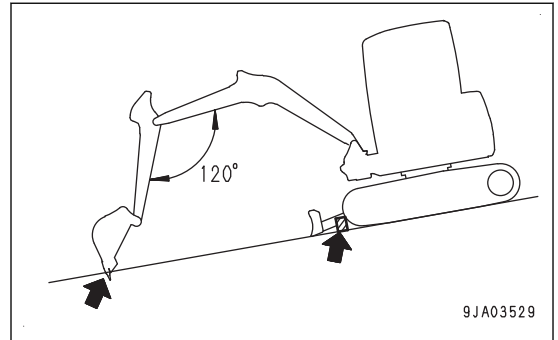

1. Set the R.H. and L.H. travel levers (1) in NEUTRAL position (N).

The machine stops.

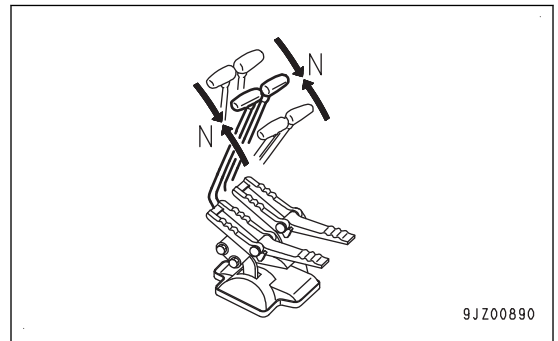

2. Turn the fuel control dial (2) to Low idle (MIN) position (a) and lower the engine speed.

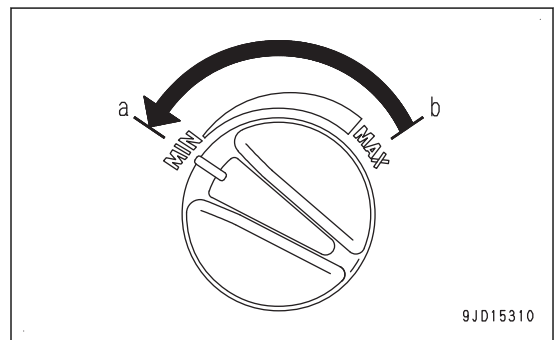

3. Set the work equipment in the posture shown in the figure.

- 1) Operate the L.H. work equipment control lever (3) and make the undercarriage and upper structure point to the same direction.
- 2) Operate the R.H. and L.H. work equipment control levers (3) and (4) to make the bottom of the bucket level and lower it to the ground.
- 3) Push the blade control lever (5) forward to lower the blade to the ground.

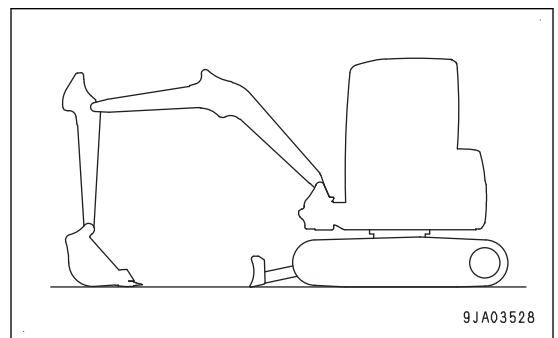

4. Set the lock lever (6) to LOCK position (L).
Be sure to operate the lock lever (6) by the operating portion on the top.

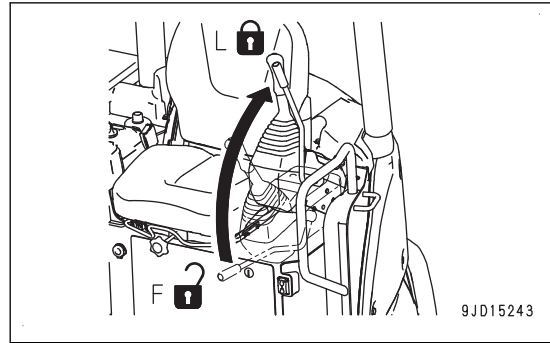

5. Check that the machine monitor (7) is in the following states.

(8) Engine coolant temperature gauge

The graduation of gauge is within normal range.

(9) Fuel gauge

The graduation of gauge is within normal range.

(10) Caution lamp display

OFF

If any problem is found, perform maintenance or repair.

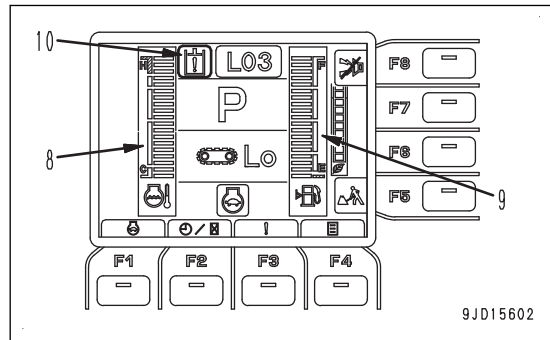

6. Stop the engine.

If the seat is positioned forward, shift it backward to keep enough space, and then get off the machine.

METHOD FOR CHECKING AFTER FINISHING WORK

Perform it after stopping the engine.

1. Walk around the machine and check the work equipment, machine exterior, and undercarriage, also check for any leakage of oil or coolant. If any problems are found, repair them.
2. Fill the fuel tank.
3. Check the engine compartment for paper and debris. Clean out any paper and debris to avoid a fire hazard.
4. Remove any mud affixed to the undercarriage.

LOCK

Always lock the following places.

REMARK

Use the starting switch key to lock and unlock all these places.

Lock positions for the machine with canopy specification

- (1) Toolbox for tools and Operation and Maintenance Manual
- (2) Dirt cover
- (3) Engine rear cover

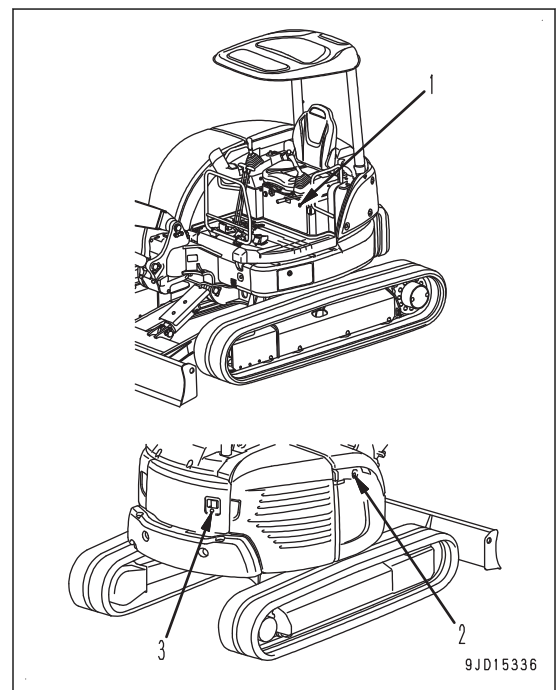

Lock positions for the machine with cab specification

- (1) Operator's cab door
Always close the window.
- (2) Dirt cover
- (3) Engine rear cover

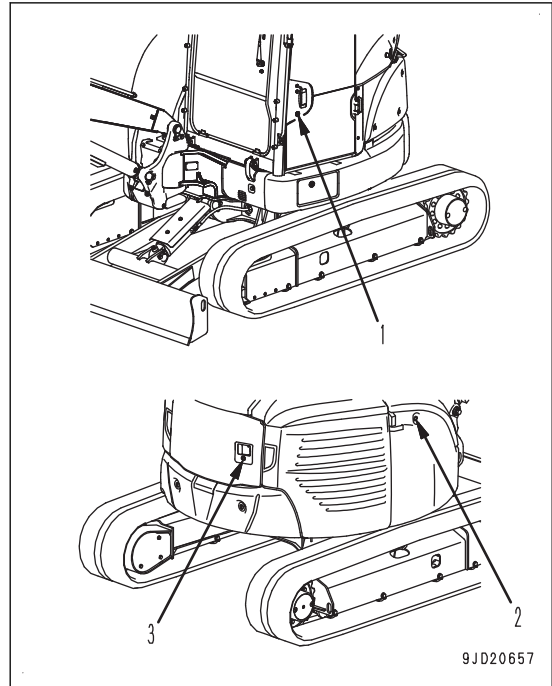

COVER WITH LOCK

Use the starting switch key to open and close the covers with locks.

Insert the starting switch key as far as it will go to shoulder (A) and turn it.

If the starting switch key is turned when it is not inserted all the way to the end, it may break.

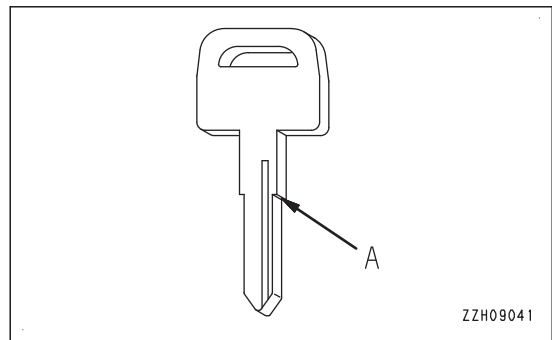

METHOD FOR OPENING AND CLOSING ENGINE REAR COVER

⚠ CAUTION

- When opening or closing the engine rear cover, place the machine on a level ground, lower the work equipment to the ground, stop the engine, and then perform the operation.
- When performing check and maintenance for inside of the engine rear cover, always open the engine rear cover fully until it is fixed with the rod.
- Immediately after the engine is stopped, the engine rear cover is still hot. Accordingly wait until it has cooled down before opening or closing the cover.
- Keep the engine rear cover closed during operation unless you perform inspection.

NOTICE

- Always keep the engine rear cover locked unless you need to open it.
- When it is locked, the engine rear cover opening knob does not move.

METHOD FOR OPENING ENGINE REAR COVER

1. Insert the starting switch key into the key slot (1).
2. Turn the starting switch key to "OPEN" position (A), and then remove the starting switch key.
Position (A)
 OPEN
Position (B)
 LOCK
3. Pull the engine rear cover opening knob (2).
 The engine rear cover (3) becomes free.
4. Pull the engine rear cover (3) toward you to open it.
 Open the engine rear cover (3) fully and it is secured by rod (4).
5. Check that the engine rear cover (3) is secured by rod (4).

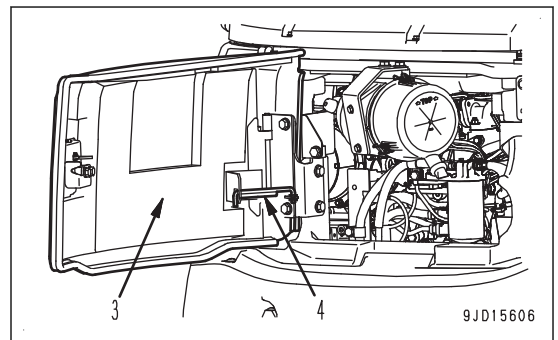
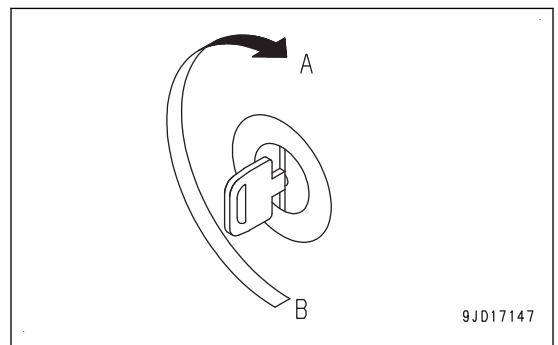
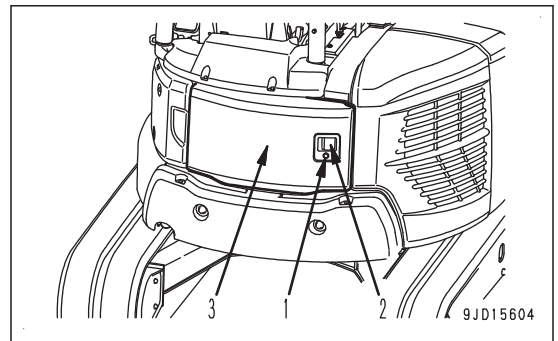

METHOD FOR LOCKING ENGINE REAR COVER

1. While lifting up the rod (4), close the engine rear cover (3) a little to release it from the groove of rod (4).
The engine rear cover (3) will be free.
2. Close the engine rear cover (3) and push it to fix securely.

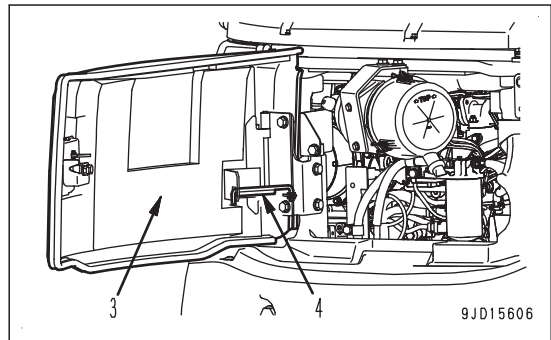

3. Insert the starting switch key into the key slot (1).

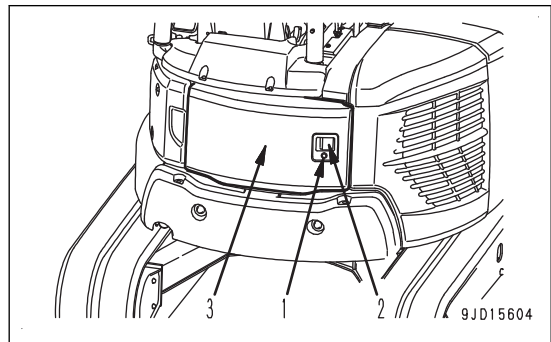

4. Turn the starting switch key to "LOCK" position (B), and then remove the starting switch key.

Position (A)

OPEN

Position (B)

LOCK

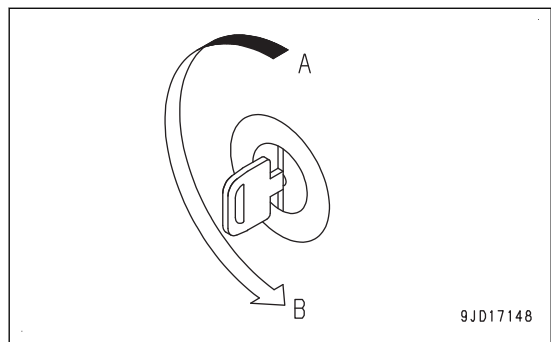

METHOD FOR OPENING AND CLOSING COOLING COVER

CAUTION

When performing check and maintenance for inside of the cooling cover, open the engine rear cover, and then open the cooling cover.

Always open the engine rear cover fully until it is fixed with the rod.

Fix the cooling cover securely with the rod at LOCK position.

METHOD FOR OPENING COOLING COVER

1. Pull up the cooling cover opening lever (1).
The cooling cover (2) becomes free.

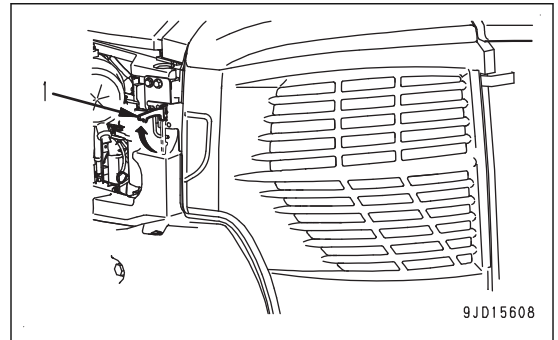

2. Pull the cooling cover (2) backward to open it.

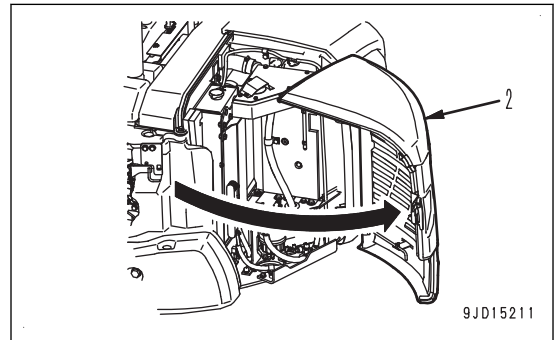

3. Move the rod (3) to LOCK position (L), and secure the cooling cover (2) with the rod.

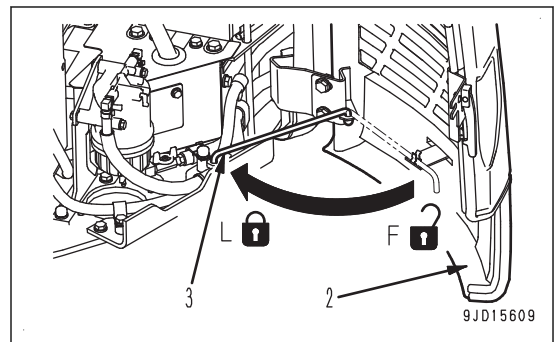

METHOD FOR CLOSING COOLING COVER

1. Set the rod (3) to FREE position (F).
The cooling cover (2) becomes free.

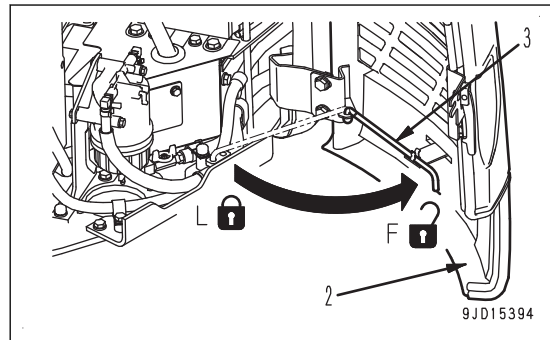

2. While pulling up the cooling cover opening lever (1), close the cooling cover (2).
3. Push down the cooling cover opening lever (1), and secure the cooling cover.

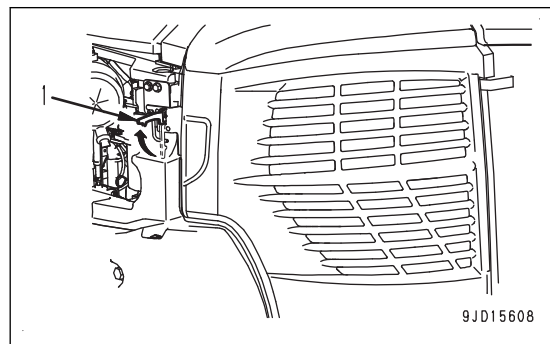

METHOD FOR OPENING AND CLOSING DIRT COVER

⚠ CAUTION

- Never stand on the cover, otherwise, you may slip and fall.
- Open the dirt cover fully, and check that it is fixed with the cover supporting lever when performing check and maintenance of the inside.
- Keep the dirt cover closed unless you perform inspection.

NOTICE

Always keep the cover locked unless you need to open it.

You can see if the cover is locked by checking the direction of the key slot of the dirt cover opening knob.

METHOD FOR OPENING DIRT COVER

1. Insert the starting switch key into the key slot of dirt cover opening knob (1).

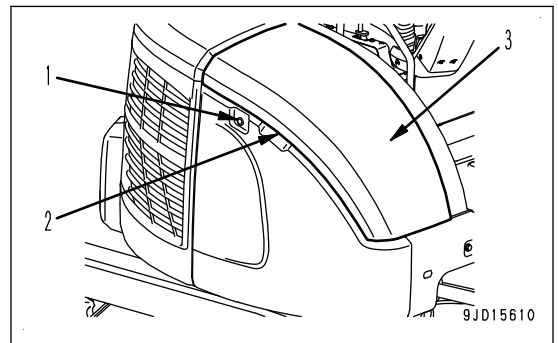

2. Turn the starting switch key to "OPEN" position (A), and then remove the starting switch key.

Position (A)

OPEN

Position (B)

LOCK

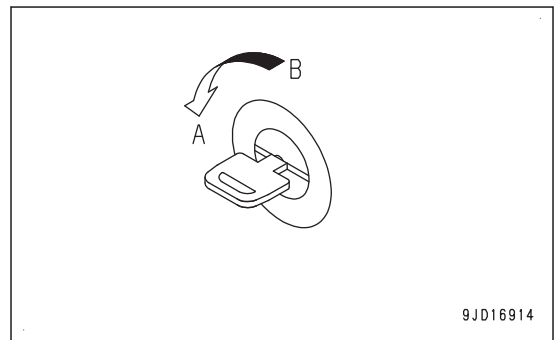

3. Push dirt cover opening knob (1).
Dirt cover (3) becomes free.

4. Hold grip part (2) and open dirt cover (3).
Open dirt cover (3) fully and it is secured by cover support lever (4).
5. Check that dirt cover (3) is secured by cover support lever (4).

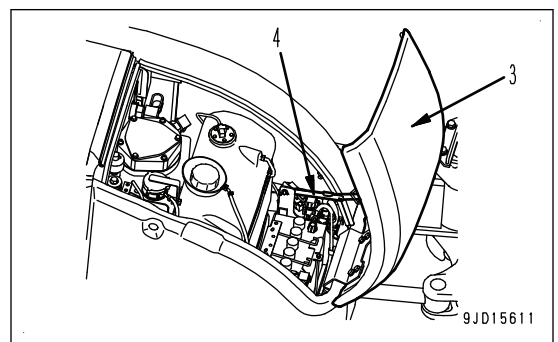

METHOD FOR LOCKING DIRT COVER

1. Hold dirt cover (3) and pull up cover support lever (4) slightly.
Dirt cover (3) becomes free.
2. Close dirt cover (3) gently and push it to fix securely.

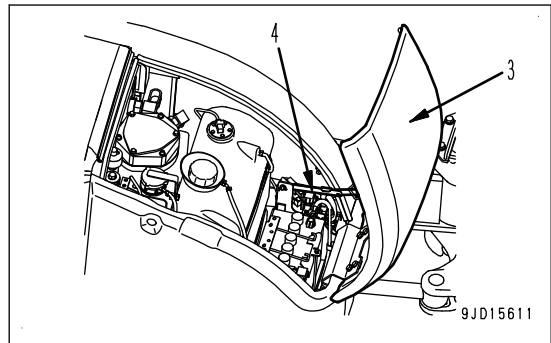

3. Insert the starting switch key into key slot (1).

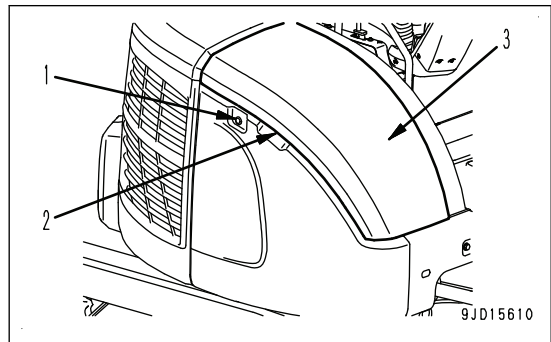

4. Turn the starting switch key to "LOCK" position (B), and then remove the starting switch key.

Position (A)

OPEN

Position (B)

LOCK

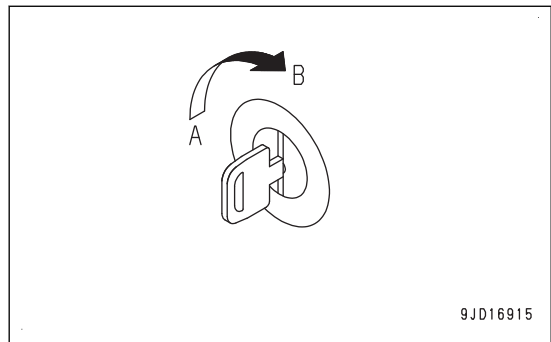

METHOD FOR OPENING AND CLOSING OPERATOR CAB DOOR

(Machine with cab specification)

WARNING

- Before releasing the door lock, always place the machine on a level ground.
- Do not release the door lock when the machine is on a slope.
The cab door may suddenly close and pinch your hand, and it causes injury.
- When releasing the door lock, do not put your arm out of cab or put your hand on the frame of cab door.
The cab door may suddenly close and cause injury.

Use the door lock to fix the cab door in an opened position.

METHOD FOR OPENING OPERATOR CAB DOOR

1. Insert the starting switch key into the key slot (1).
2. Turn the starting switch key to "OPEN" position (A), and then remove the starting switch key.

Position (A)
OPEN

Position (B)
LOCK
3. Hold the cab door handle (2) to open the cab door.

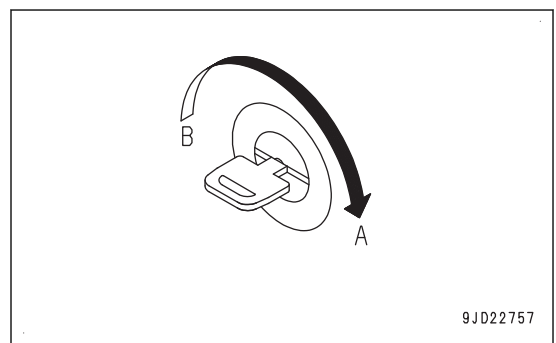
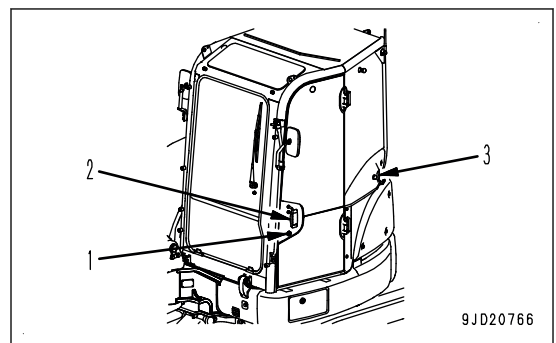

4. Hold the handle inside cab door, and push the cab door to the door lock (3), and fix it securely.
5. Check that the cab door is securely fixed to the door lock (3).

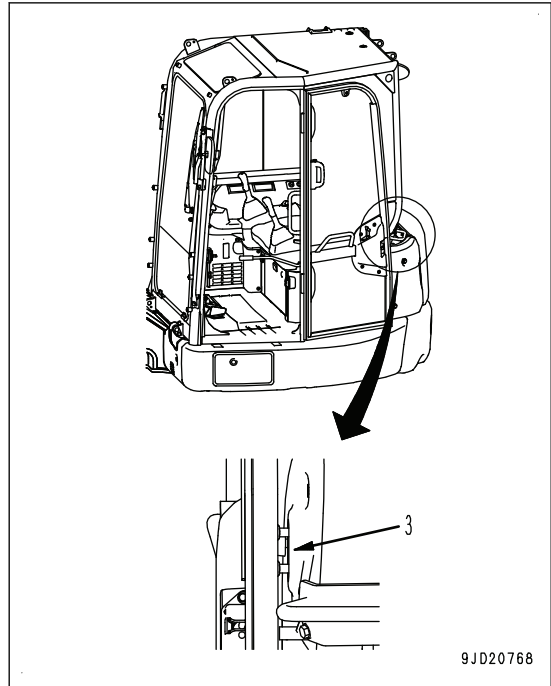

9J020768

METHOD FOR LOCKING OPERATOR CAB DOOR

1. Lower the door lock cancel lever (4) to release the door lock (3).

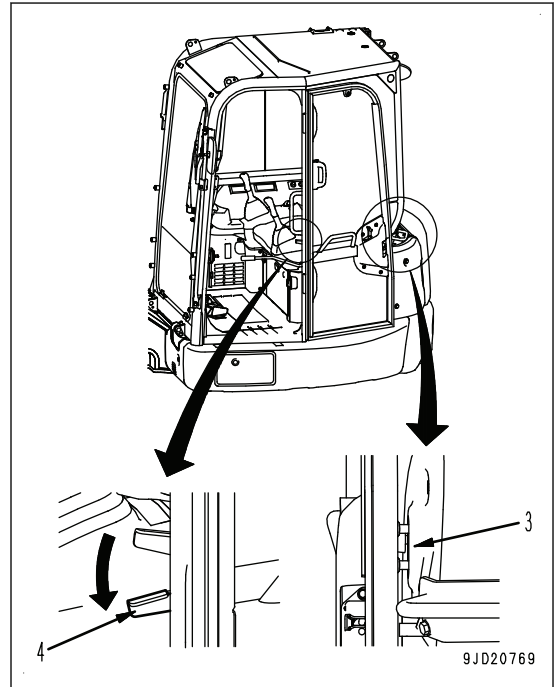

2. Hold the handle inside the cab door and pull the cab door, and hold the cab door handle (2) to close the cab door.
3. Insert the starting switch key into the key slot (1).

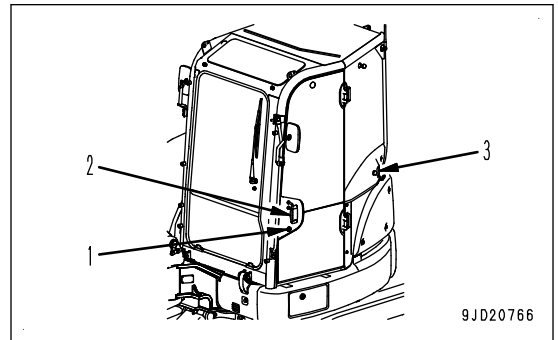

4. Turn the starting switch key to "LOCK" position (B), and then remove the starting switch key.

Position (A)

OPEN

Position (B)

LOCK

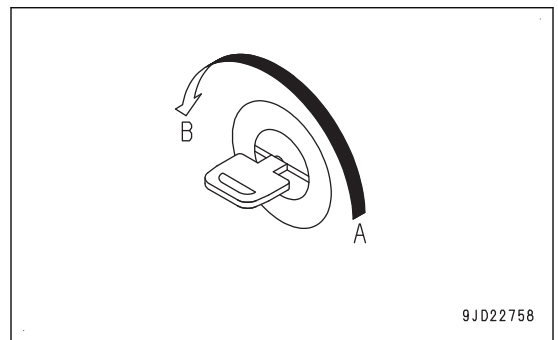

HANDLE AIR CONDITIONER

(Machine with cab specification)

- When the air conditioner is not used every day, to prevent loss of the film of oil at various parts, run the air conditioner with the engine at low speed from time to time and perform cooling or dry heating for several minutes.
- When the temperature inside the cab is low, the air conditioner may not work. In this case, circulate recirculation air to warm the inside of the cab. After that, turn on the air conditioner switch, the air conditioner will work.

Ventilation while cooling

- When running the air conditioner for a long time, turn the lever to FRESH position once an hour to perform ventilation and cooling.
- If you smoke when the air conditioner is on, the smoke may hurt your eyes. In such case, open the window and turn the lever to FRESH for a while for ventilation and cooling to discharge the smoke.

Temperature control

For reasons of health, the optimum setting for cooling is considered to be that you feel slightly cool when you enter the cab (5 to 6 °C {41.0 to 42.8 °F} lower than the ambient temperature).

Be careful to select the appropriate temperature.

Phenomena that are not failures

While operating or driving the machine, it takes some time that air conditioner starts working. This is due to lowering of hydraulic pump output, and not a failure.

EXPLANATION OF AIR CONDITIONER EQUIPMENT

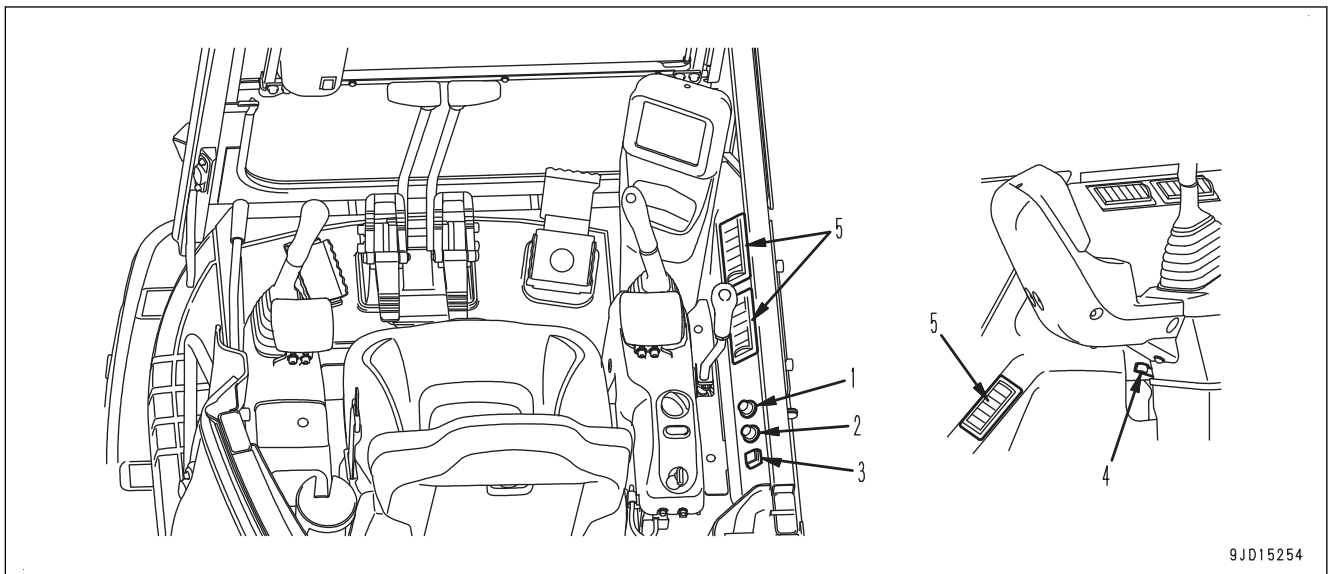

(1) Temperature control switch

(2) Air flow selector switch

(3) Air conditioner switch

(4) FRESH/RECIRC air selector lever

(5) Vent

TEMPERATURE CONTROL SWITCH

Use the temperature control switch to adjust the inside temperature.

Lower the inside temperature.

Turn the temperature control switch counterclockwise.

Raise the inside temperature.

Turn the temperature control switch clockwise.

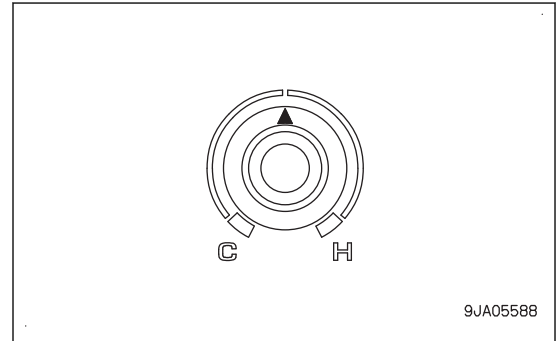

9JA05588

AIRFLOW SELECTOR SWITCH

Air flow selector switch can adjust air flow in 3 levels.

(3) High position

Air flow rate is high.

(2) Medium position

Air flow rate is medium.

(1) Low position

Air flow rate is low.

(0) OFF position

Air flow stops.

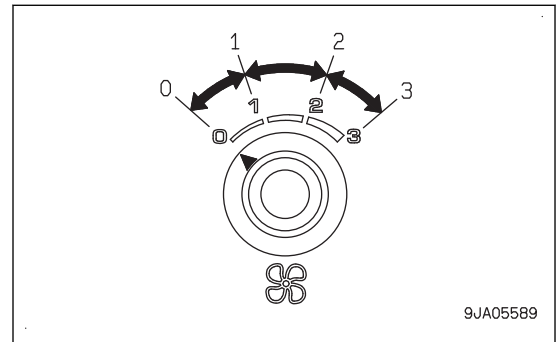

9JA05589

AIR VENT

Blow direction can be adjusted by turning the louver of each vent.

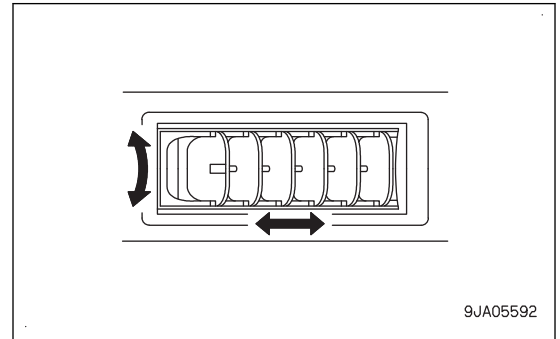

9JA05592

FRESH/RECIRC AIR CHANGEOVER LEVER

Use FRESH/RECIRC air selector lever to switch the air source between recirculation of the air inside the cab and intake of fresh air from the outside.

(a) FRESH

Outside air is taken into the cab.

Use this setting to take in fresh air or to demist the window glass.

(b) RECIRC

Outside air is shut off and only air inside the cab is circulated.

Use this setting to perform rapid cooling of the cab or when outside air is dirty.

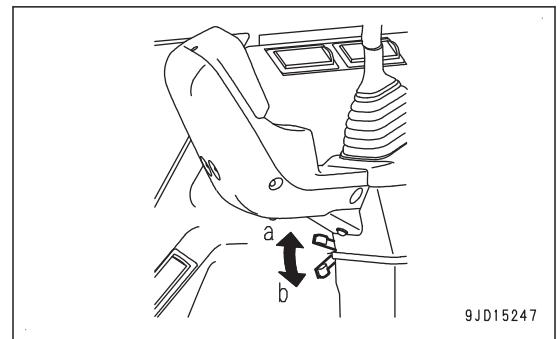

9JD15247

AIR CONDITIONER SWITCH

Each time the air conditioner switch is pressed, operation (ON) and stop (OFF) is switched.

When the air conditioner switch is turned to operation (ON), the lamp inside the air conditioner switch lights up.

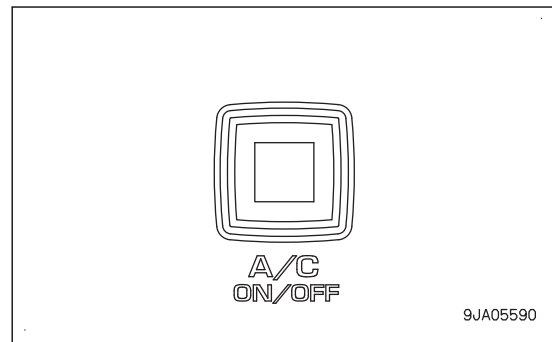

METHOD FOR OPERATING AIR CONDITIONER

METHOD FOR STARTING AIR CONDITIONER

1. Turn the air flow selector switch, and adjust the air flow.

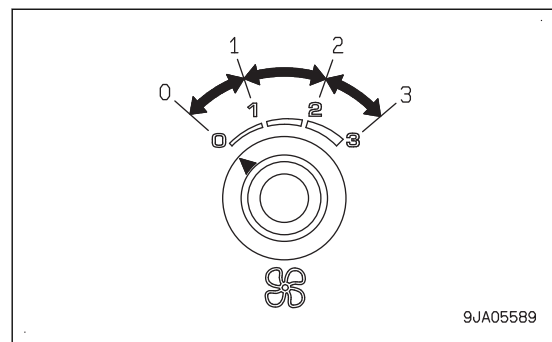

2. Press the air conditioner switch, and turn it on.
The lamp inside the switch lights up.

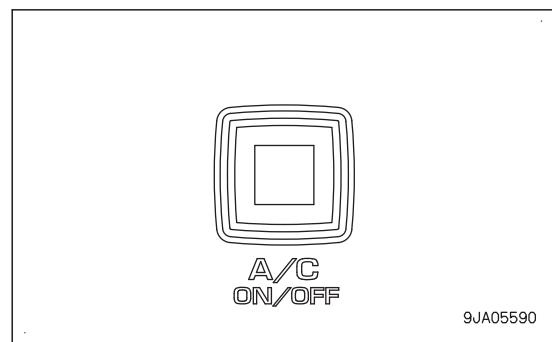

3. Turn the temperature control to adjust to the desired temperature.

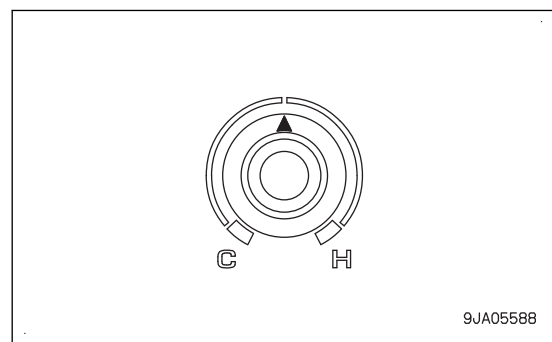

- Turn the louver of each vent to adjust to the desired vent direction.

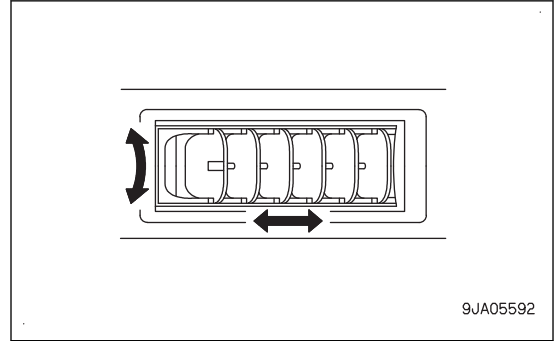

- Change the FRESH/RECIRC air selector lever to select either FRESH (a) or RECIRC (b).

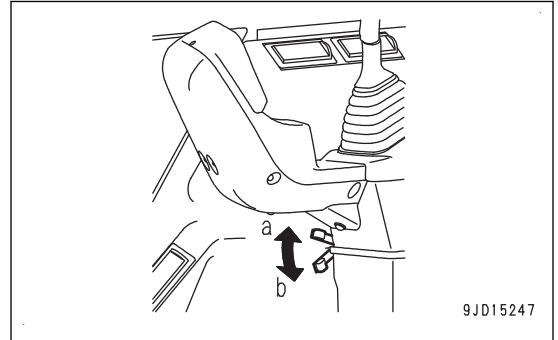

METHOD FOR STOPPING AIR CONDITIONER

- Press the air conditioner switch, and turn it off.
The lamp inside the switch goes out.

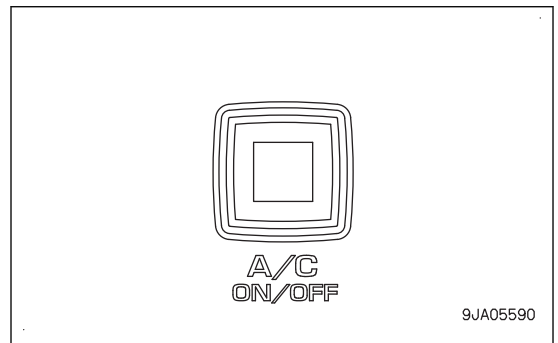

- Turn the air flow selector switch to "0", and stop the air flow.

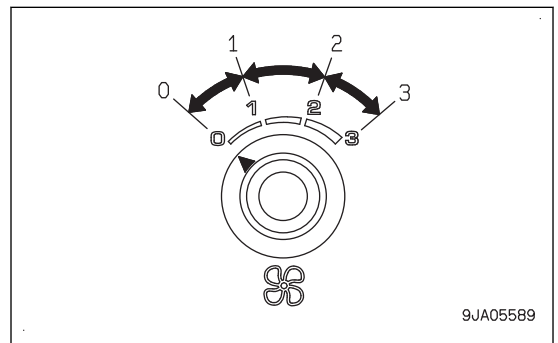

HANDLE RUBBER AND ROAD LINERS SHOES

RECOMMENDED USE OF RUBBER AND ROAD LINERS SHOES

The rubber shoes and road liners have good features which the steel shoes do not have. However, if it is used similarly to the steel shoes, its features are not used fully.

Avoid using them forcibly, depending on the condition of the site and contents of work.

COMPARISON OF RUBBER ,ROAD LINERS SHOES AND STEEL SHOES

	Rubber shoe	Road liner	Steel shoe
Less vibration	◎	◎	△
Smooth travel (No creak)	◎	○	○
Small sound	◎	◎	△
No risk of damaging pavement	◎	◎	△
Easy to handle	◎	△	△
Resistant to damage	△	○	◎
Large traction force	◎	◎	◎

◎: Very good

○: Good

△: Fair

Considering the properties of the material used, rubber shoes and road liners offer various advantages. However, their weak point is a lack of strength. Accordingly, you can extend the service life of the rubber shoes and road liner, and use its advantages fully, by understanding their features and observing the precautions for prohibited work and handling.

WARRANTY OF RUBBER AND ROAD LINERS SHOES

The warranty does not cover any damage caused by the machine usage which is not described in the Operation and Maintenance Manual, including neglect of check and maintenance of the track tension, disregard of prohibited matter such as "operation on the corners of a steel plate, a U-bend trap, a concrete block, reinforcing bars, scrap steel, etc. which can cut the road liner" and precautions.

PROHIBITED OPERATIONS WHEN USING RUBBER AND ROAD LINERS SHOES

Do not perform the following work.

- If the machine is operated or swung on crushed stones, very irregular hard rock-bed, reinforcing bars, scrap steel, edges of steel plates, the rubber shoes and road liners can be damaged.
- In a riverbed, etc. where there are many large boulders, the rubber shoes and road liners may be damaged by stones caught in them and they may come off the rollers.
If the machine is used to doze forcibly while the shoes slip, the service life of the rubber shoes and road liners is shortened.
- Take care that oil, fuel, or chemical solvent does not stick to the rubber shoes and road liners. If any of them sticks, wipe it off immediately.
Do not travel on a road where oil, etc. is accumulated.
- When storing the machine for a long period (3 months or more), store it indoors to avoid direct sunlight and rain.
- Do not drive the machine into a high temperature place such as a bonfire, steel plate exposed to the hot sun, newly spread asphalt, etc.
- If the machine moves on only the track on either side while the track on the other side is raised with the work equipment, the rubber shoes may come off the rollers or may be damaged.
- If the rubber parts of the road liner are worn and damaged and the mounting bolt heads are damaged, replace the shoes with new ones immediately.
If the mounting bolt heads are crushed, they cannot be removed or installed anymore.
- When installing the road liner, always install to all the links of the right and left tracks.
If it is installed partially or to only one portion, its service life is shortened remarkably.

PRECAUTIONS FOR USING RUBBER AND ROAD LINERS SHOES

When operating, observe the following.

- Do not make a pivot turn on a concrete road since rubber marks are made on the road surface.
- Avoid turning sharply whenever possible, since that can cause early wear and chipping of the rubber shoes and road liners.
- Avoid turning on a large level difference.
When riding over a level difference, travel perpendicularly to it to prevent the shoes from coming off.
- Once you raise the machine by using the work equipment, lower it slowly.
- Avoid handling crushed and oily material (cakes of soybean, corn, rapeseed, etc.) or wash the machine with water after the work.
- Do not use the rubber shoes and road liners on seashore since the adhesive of the core metal is corroded by the salt.
- When the rubber shoes and road liners are used to handle salt, sugar, wheat, soybeans, etc., if they have a deep cut, rubber chips may be mixed in the handled material. To prevent this, repair any cut before using.
- Do not rub the rubber shoes and road liners against concrete ridges, walls, etc. during operation.
- The rubber shoes and road liners are very slippery on wet steel plates, snow-covered or frozen road surfaces.
Beware of slip when traveling on a face of slope or operating on a slope.
- If the rubber shoes and road liners are used in an extremely cold district, their material quality change and their service life are shortened accordingly.
- Use the rubber shoes in a range from -25 to 55 °C { -13 to 131 °F} due to the properties of rubber.
Use the road liners in a range from -25 to 65 °C { -13 to 149 °F}.
- Take care not to damage the rubber shoes and road liners with the bucket during operation.
- Keep the rubber shoe tension proper to prevent the rubber shoes from coming off the rollers.
When the rubber shoes tension is loose in the following conditions, the rubber shoes may sag and come off.
Even if the rubber shoes tension is correct, the rubber shoes may sag in such conditions, be extremely careful when steering the machine.

1. Do not steer the machine on curb stones or rocks where there are level differences (approximately 20 cm or more {7.9 in or more}).
When riding over a level difference, drive at right angles to it.

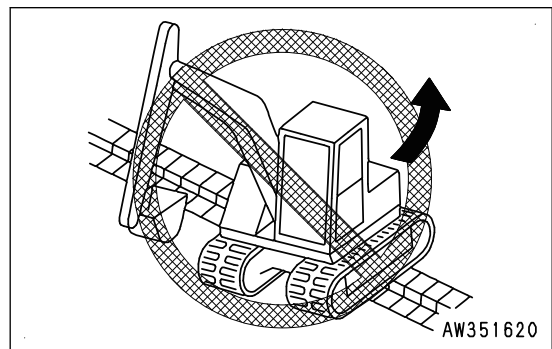

2. When traveling uphill in reverse do not steer on the line between the level ground and the slope.
If it is obliged to steer while traveling uphill, steer slowly.

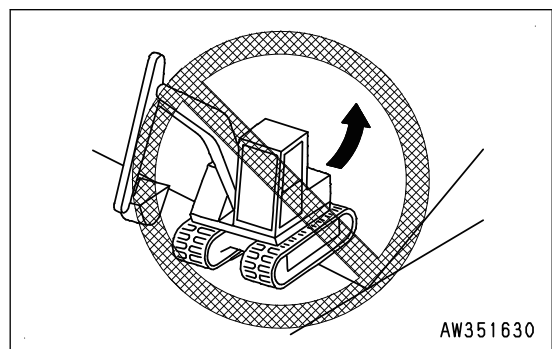

3. Do not travel with either track raised on a face of slope or convex ground surface (with the machine leaning approximately 10° or more) and the other track on the level ground.

Travel with both tracks on the same level to protect the rubber shoes and road liners from being damaged.

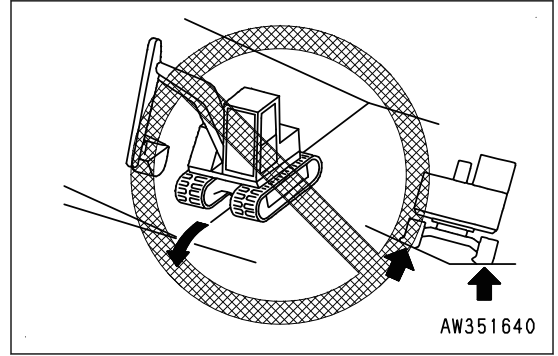

4. Avoid steering in the posture shown in the figure.

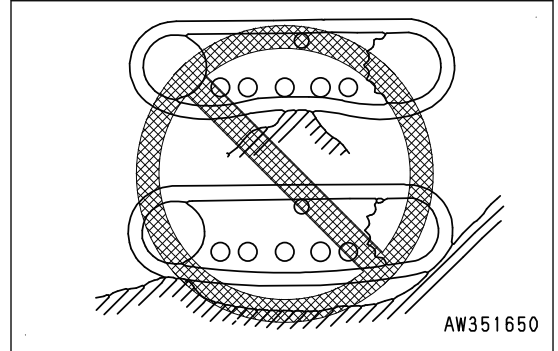

Mechanism that rubber shoe comes off

The rubber shoe comes off in the following cases.

- When riding over a level difference by driving the machine in reverse.

1. Clearance (a) is made between track rollers (1) and rubber shoes (2).

Rubber shoe (2) may come off even under this condition.

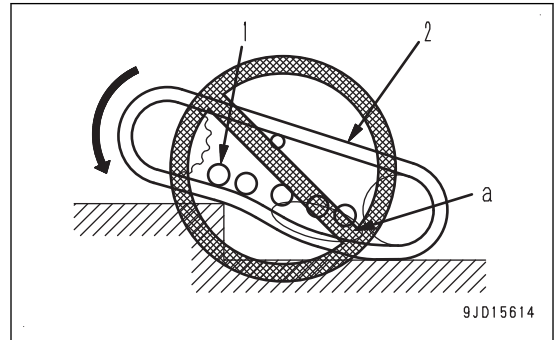

2. When the machine travels further in reverse, clearance (b) is made between track roller (1), idler (3), and rubber shoe (2).

Rubber shoe (2) comes off under this condition.

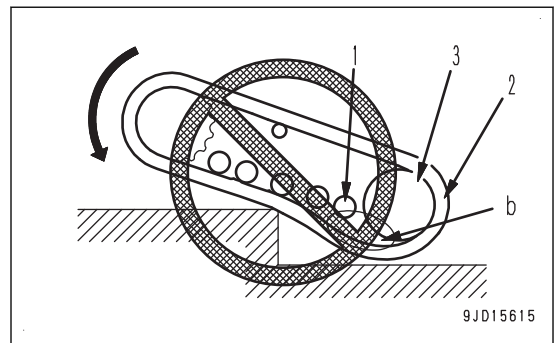

- When the machine is steered while the rubber shoe cannot move sideways because of a material to ride over or another thing.

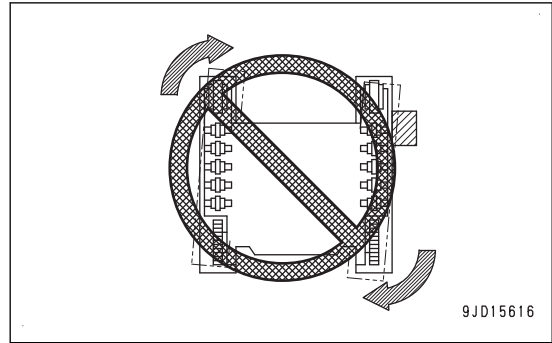

- When the idler or track rollers deviate from the core metal because of misalignment of the rubber shoes.

(A): Frame side

(B): Rubber shoe side

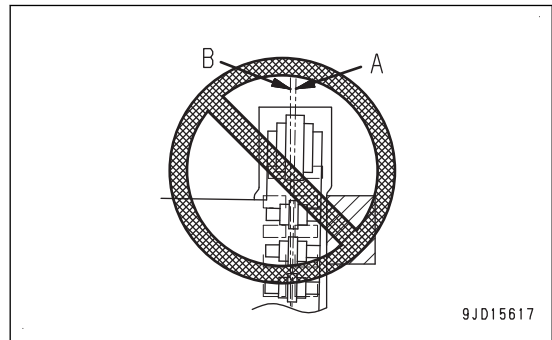

- When the machine travels in reverse with idler under the condition shown in the figure.

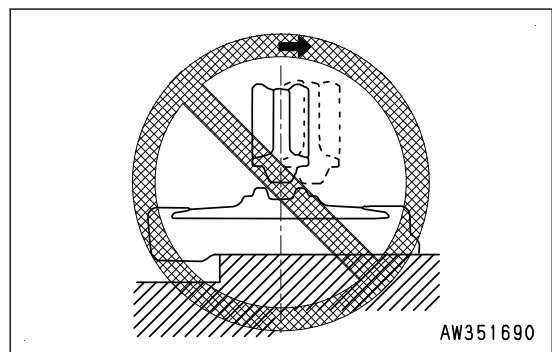

- When the machine turns with track roller under the condition shown in the figure.

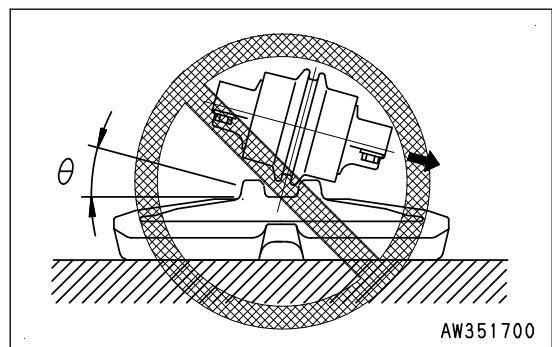

TRANSPORTATION

PRECAUTIONS FOR TRANSPORTING MACHINE

SELECT TRANSPORTATION METHOD

When transporting the machine, choose the transportation method in reference to the weight and dimensions shown in "SPECIFICATIONS".

Note that the weight and dimension shown in "SPECIFICATIONS" may differ in accordance with the type of track shoe or arm, or other attachments.

LOADING AND UNLOADING WITH TRAILER

PRECAUTIONS FOR LOADING AND UNLOADING WITH TRAILER

Precautions for loading and unloading operations

WARNING

Always observe the following when loading or unloading the machine onto/from a trailer.

- Select the firm, level ground when loading or unloading the machine.
- Maintain a safe distance from the road shoulder.
- Check that the travel speed display shows Lo, and perform the loading or unloading of machine at low speed.
- Always set the travel speed to low speed (Lo), run the engine at low idle, and perform the loading or unloading of machine.
- Perform the warm-up operation thoroughly and make sure that the engine speed is stable before performing the loading or unloading of machine.
- Never correct your steering on the ramps. There is a danger that the machine may tip over. If necessary, drive off the ramps or back on to the trailer and correct the direction.
- On the ramps, operate only the travel lever. Do not operate any other lever.
- It is dangerous to use the work equipment for loading and unloading operations. Always use ramps.
- The center of gravity of the machine shifts suddenly at the joint between the ramps and the trailer, and it is dangerous that the machine loses its balance. Accordingly, pass this point slowly.
- If it is necessary to swing the upper structure on the trailer platform, the footing is unstable, so be extremely careful that the machine does not tip over. If the work equipment is installed to the machine, pull the work equipment in, and operate slowly to prevent the machine from losing its balance.
- Position a flagman to give guidance to prevent the machine from coming off the ramps and to ensure safety in the operation.
- For the machine equipped with cab, door must be locked either at the open position or closed position. Avoid opening or closing the door on the ramps or trailer platform because the operating effort may suddenly change.

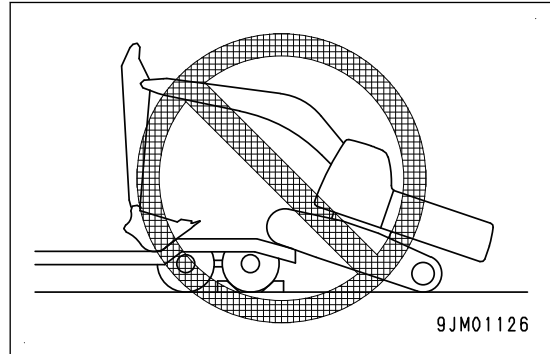

Precautions for ramps and platform

⚠ WARNING

Always observe the following regarding the ramps and platform.

- Use ramps with ample width, length, thickness, and strength and install them with a slope of 15 ° or less.

When using piled soil for the platform, compact the piled soil fully to prevent the slope face from collapsing.

- Clean the machine tracks and ramps before starting in order to prevent the machine from slipping on the ramps.

There is danger of the machine slipping if there is water, snow, grease, oil, or ice on the machine tracks or ramp surface.

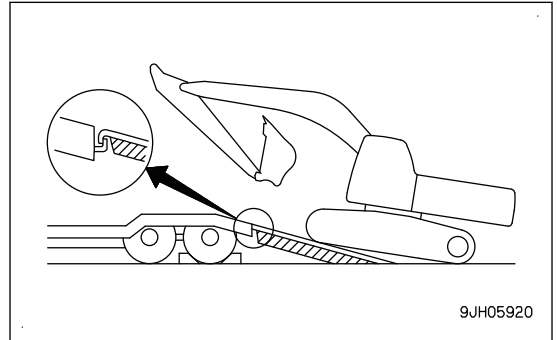

PROCEDURES FOR LOADING MACHINE

1. Park a trailer on a flat and firm place.
Maintain a safe distance from the road shoulder.
2. Apply the trailer brakes securely, then put chocks (1) under the tires to prevent the trailer from moving.
3. Set the right and left ramps (2) parallel to each other and equally spaced to the right and left of center (3) of the trailer. Make the installation angle (A) at 15 ° or less.
If the ramps bend largely under the weight of the machine, put blocks under the ramps to prevent them from bending.

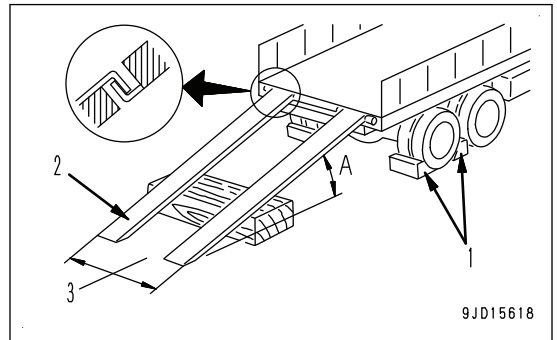

4. Turn the fuel control dial to Low idle (MIN) position (a).

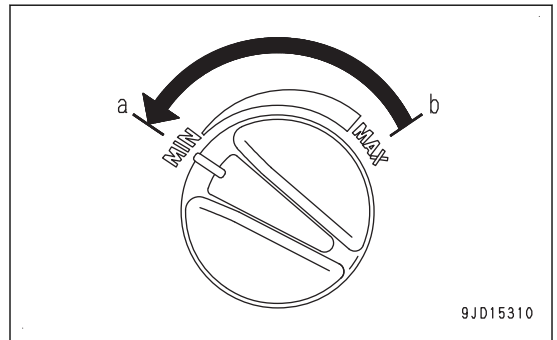

5. Check that the travel speed display shows Lo.

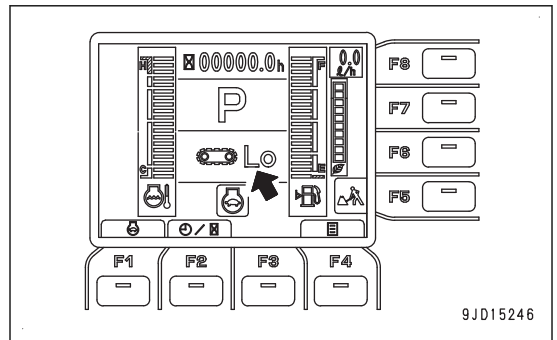

If Hi is displayed, press the travel speed selector switch to change the travel speed to Lo.

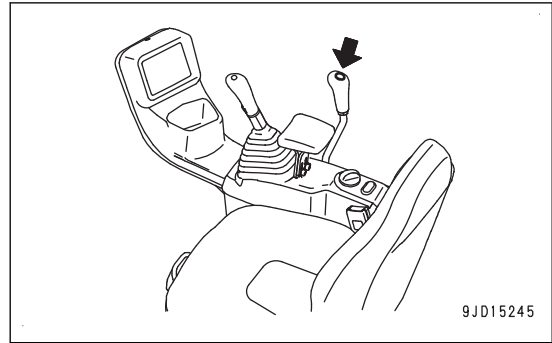

- 6. Set the lock lever to FREE position (F).
Be sure to operate the lock lever by the operating portion on the top.

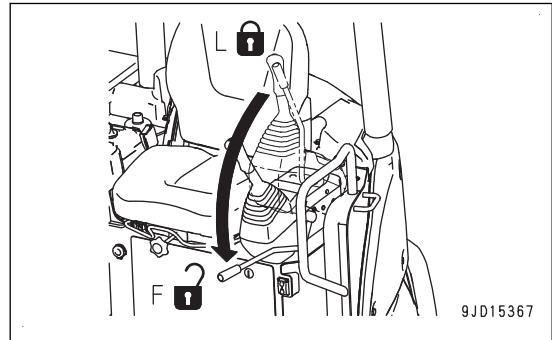

- 7. Operate the work equipment control lever to swing the upper structure so that the work equipment is on the sprocket side.
At this time, set the undercarriage and upper structure in parallel.
- 8. Before moving the machine onto the ramps, check that the machine is positioned in a straight line with the ramps and that the centerline of the machine matches that of the trailer.
- 9. Pull the travel levers backward and drive the machine slowly toward the ramps.

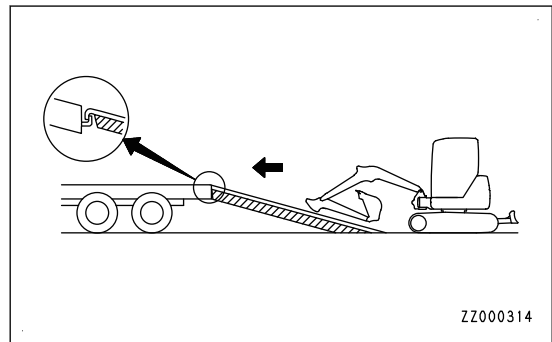

Lower the work equipment as far as possible without causing interference.
On the ramps, do not operate any other lever than travel lever.

- 10. When the machine rides on the platform of the trailer, stop the machine and swing the upper structure slowly by 180 °.

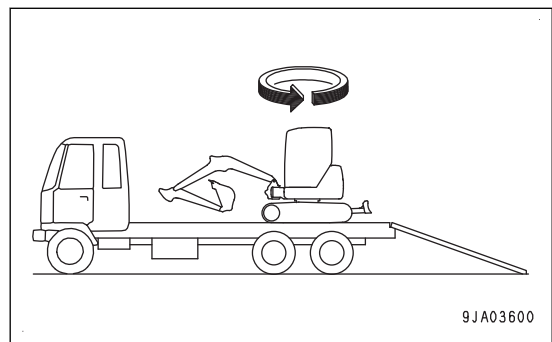

11. Place the machine at the specified position on the trailer.

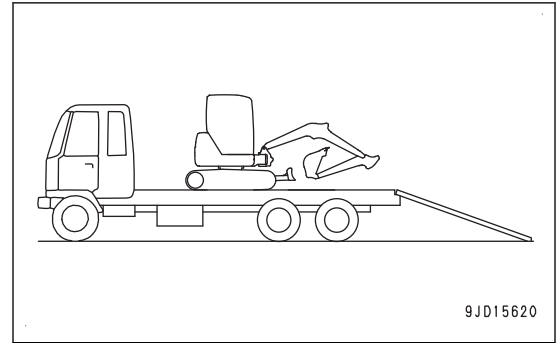

METHOD FOR SECURING MACHINE

NOTICE

- To prevent damage to the bucket cylinder during transportation, put a wooden block under the tip of the bucket link to prevent the bucket cylinder from touching the floor.
- Do not use the fixing hole at the rear of the track frame for towing or lifting the machine.

After loading the machine onto a trailer, secure the machine as follows.

1. Set the machine in the posture shown in the figure.
 - 1) Push the blade control lever forward to lower the blade to the ground.
 - 2) Operate the work equipment control levers to extend bucket cylinder and arm cylinder to their stroke end, and then lower the boom gently.
Put a block under the tip of the bucket link to prevent the bucket cylinder from touching the floor.
 - 3) Set the lock lever securely to LOCK position (L).
Be sure to operate the lock lever by the operating portion on the top.
 - 4) Stop the engine, then remove the key from the starting switch.
2. Close all of the doors, windows, and covers.
3. Lock all of the doors and covers which have lock.
4. Prevent the machine from moving during transportation, by putting wooden blocks on the front and rear sides of the tracks.
5. Fix the machine securely with chains or wire ropes of proper strength to prevent it from side slip.

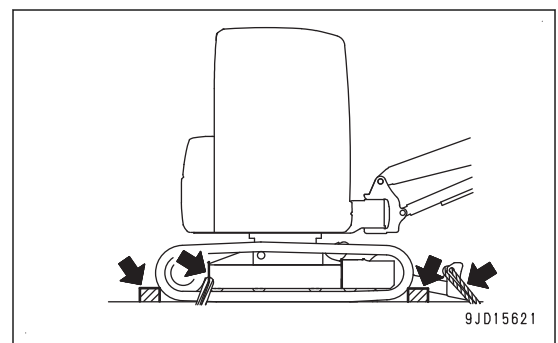
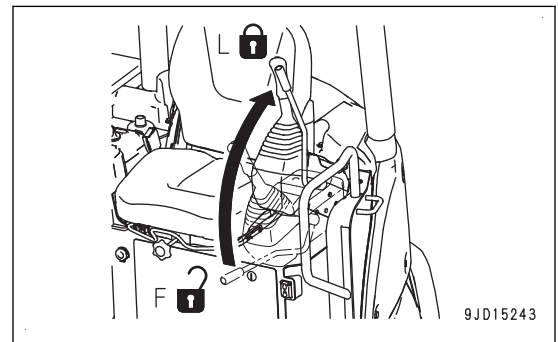
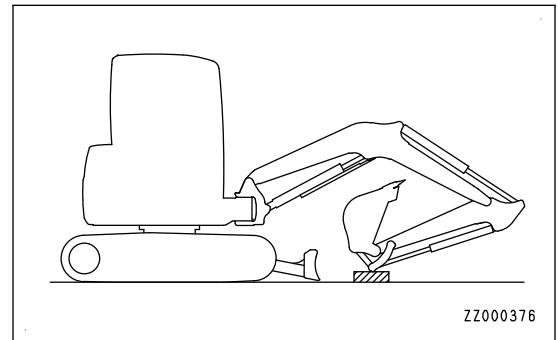

REMARK

Use the hole at side plate of blade and fixing hole at rear of the track frame to secure the machine with the chain or wire rope.

PROCEDURES FOR UNLOADING MACHINE

1. Park a trailer on a flat and firm place.
Maintain a safe distance from the road shoulder.
2. Apply the brake of the trailer securely.
3. Set the chocks (1) to the tires to secure the trailer.
4. Set the right and left ramps (2) parallel to each other and equally spaced to the right and left of center (3) of the trailer. Make the installation angle (A) at 15 ° or less.
If the ramps bend largely under the weight of the machine, put blocks under the ramps to prevent them from bending.
5. Remove the chains or wire ropes which are fastening the machine.
6. Start the engine.
Warm up the engine fully in cold weather.
7. Check that the travel speed display shows Lo.

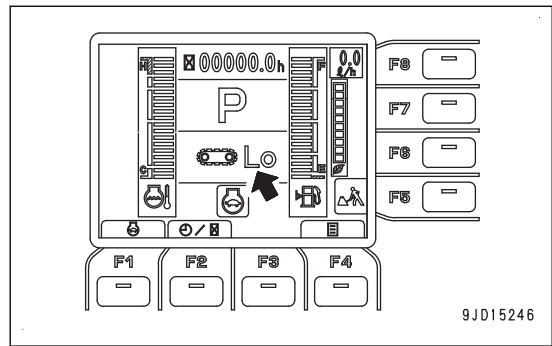
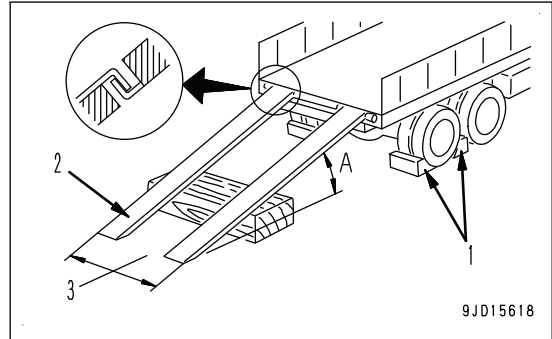

If Hi is displayed, press the travel speed selector switch to change the travel speed to Lo.

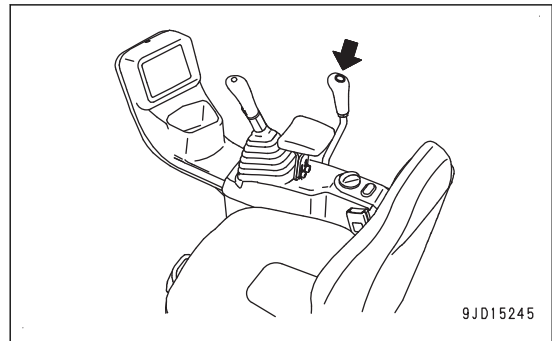

8. Turn the fuel control dial to Low idle (MIN) position (a).

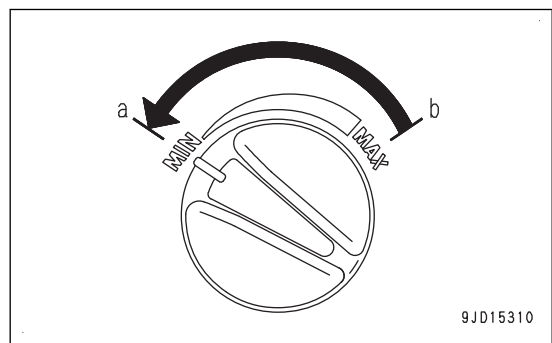

9. Set the lock lever to FREE position (F).
Be sure to operate the lock lever by the operating portion on the top.

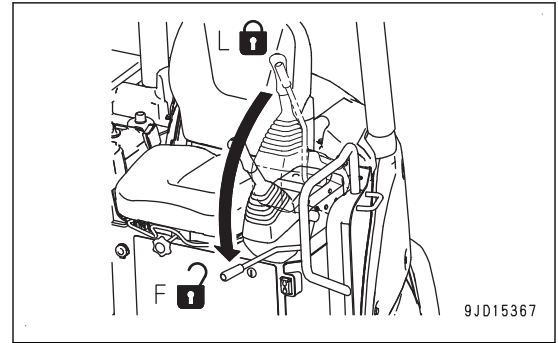

10. Set the machine in the posture shown in the figure.
- 1) Pull the blade control lever backward to raise the blade.
 - 2) Operate the work equipment control levers, and raise the work equipment.

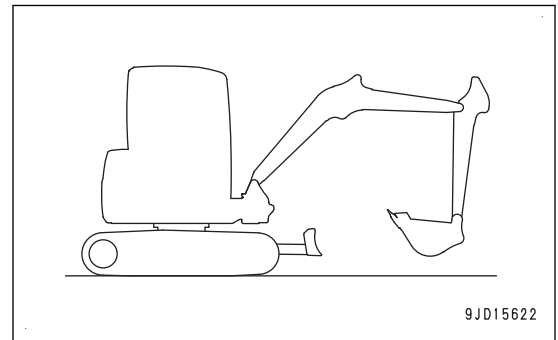

11. Push the travel levers forward and drive the machine slowly toward the ramps.
Lower the work equipment as far as possible without causing interference.
On the ramps, do not operate any other lever than travel lever.

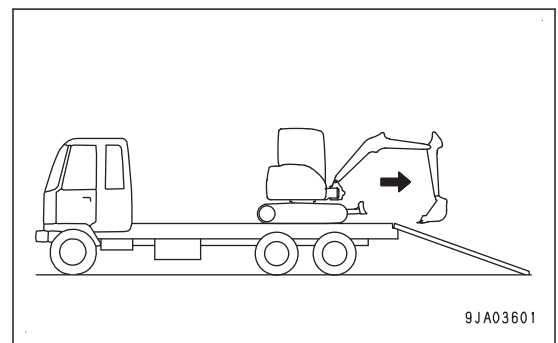

METHOD FOR LIFTING MACHINE

WARNING

- The person using the crane to perform lifting operations must be a qualified crane operator.
- Do not lift the machine with someone in it.
- Always use a wire rope that has ample strength for the weight of the machine.
- When lifting, keep the machine horizontal.
- When performing lifting operations, set the lock lever to LOCK position to prevent the machine from moving unexpectedly.
- Never enter the area under or around a lifted machine.

Never try to lift the machine in any posture other than the posture given in the following procedures nor using other lifting equipment.
There is a danger that the machine loses its balance.

CAUTION

- Do not lift the machine by using lifting hooks (4 places) on top of the cab. If you do so, cab will be broken, so never use these hooks.
- Do not lift the machine by using the holes which are prepared for fixing the track frame at transportation. If you do so, track frame will be broken, so never use these holes.

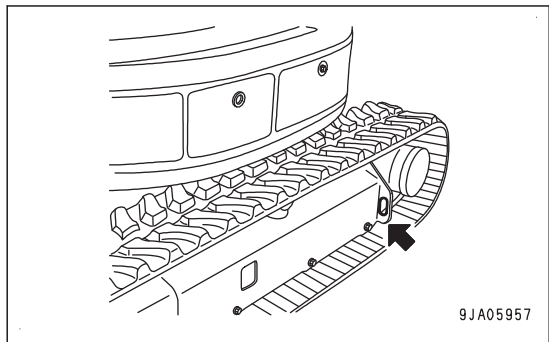
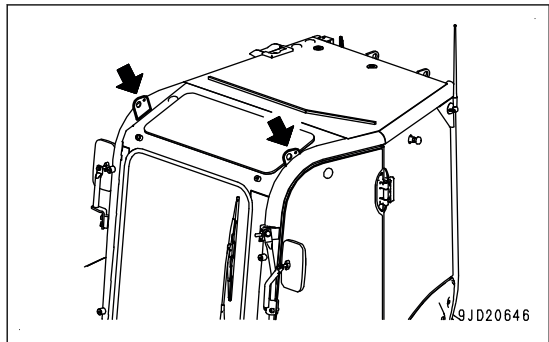

NOTICE

This lifting method applies to the standard specification machine.

The method of lifting differs depending on the attachments and options installed.

For the procedure for machines that are not the standard specification, consult your Komatsu distributor.

For the weight, see "SPECIFICATIONS".

When lifting the machine, perform the operation on a flat ground according to the following procedure.

1. Set the machine in the posture shown in the figure.
 - 1) Start the engine, and run it at low speed.

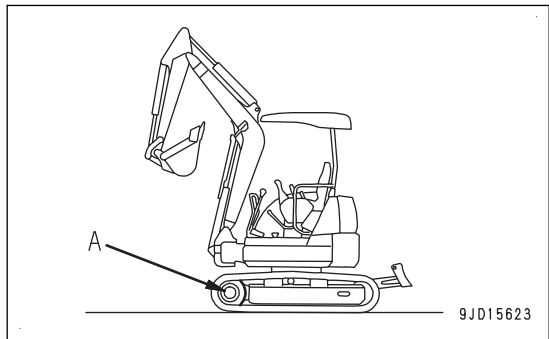

- 2) Set the lock lever to FREE position (F).
Be sure to operate the lock lever by the operating portion on the top.

- 3) Operate the work equipment control lever to swing the upper structure so that the work equipment is on the sprocket side (A).
At this time, set the undercarriage and upper structure in parallel.

- 4) Pull the blade control lever toward you to raise the blade fully.

- 5) If the boom is swung to either right or left, operate the boom swing control pedal to swing the boom so that it comes parallel to the undercarriage.

After controlling the boom swing control pedal, set the swing lock cover to LOCK position.

- 6) Operate the work equipment control levers, and extend the bucket cylinder, arm cylinder, and boom cylinder to their stroke end.

- 7) Set the lock lever to LOCK position (L).
Be sure to operate the lock lever by the operating portion on the top.

- 8) Stop the engine.

- 2. Check that there is nothing around the operator's seat, and then get off the machine.

When the machine is equipped with cab, close the cab door and front window, etc. securely.

- 3. Install shackles to the holes (2 places) for lifting at both ends of blade, and set the wire ropes.

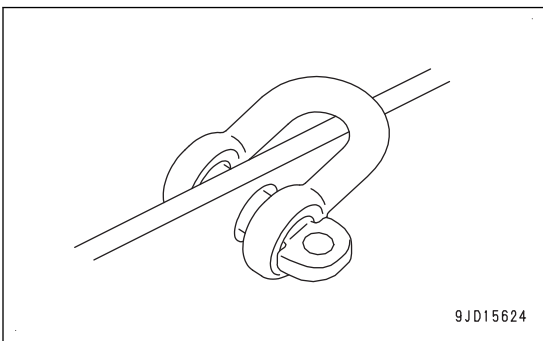
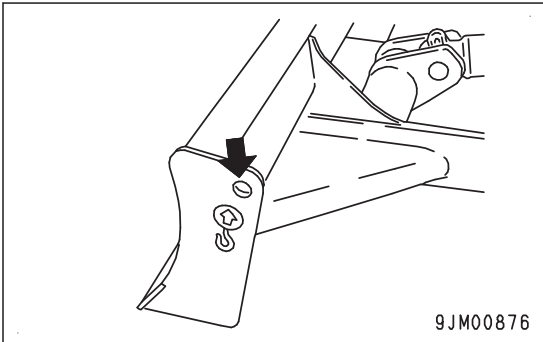
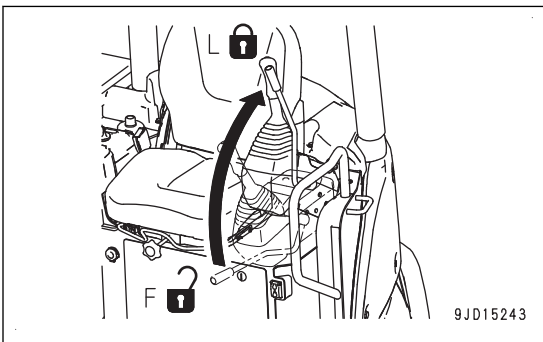
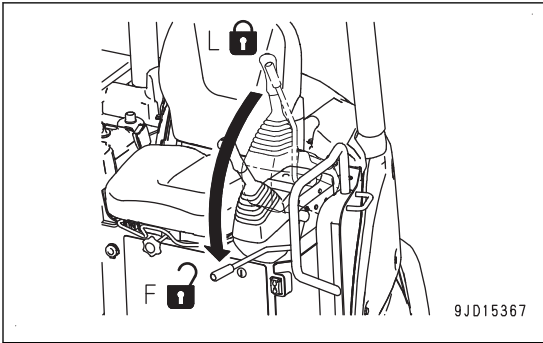

4. Install shackle to the hole (1 place) for lifting at the bracket of boom, and set the wire rope.

NOTICE

- **Be sure to use all 3 holes for lifting.**
Do not sling the machine with the boom swung or upper structure swung.
- **Be careful not to pinch the hoses.**

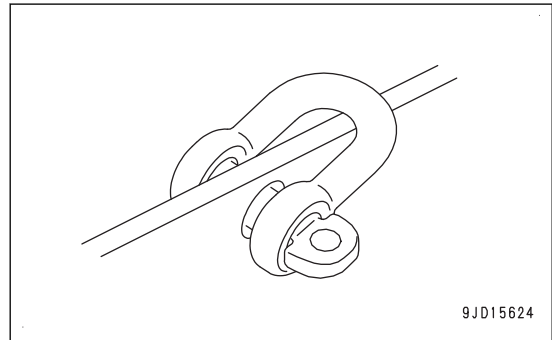
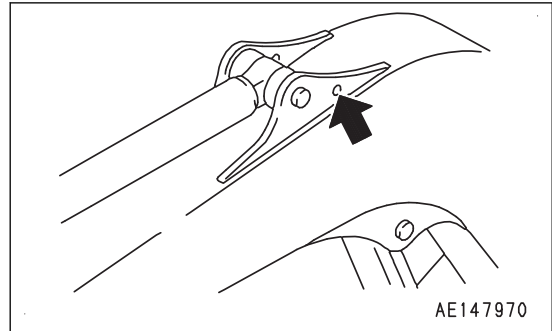

5. Set the lifting angle (a) between the front and rear wire ropes at 30 to 40 °, and then sling the machine slowly upward.
6. After the machine comes off the ground, check the hook condition and the lifting posture, and then sling the machine slowly upward.

NOTICE

Take care that wire rope does not contact to the canopy or cab.

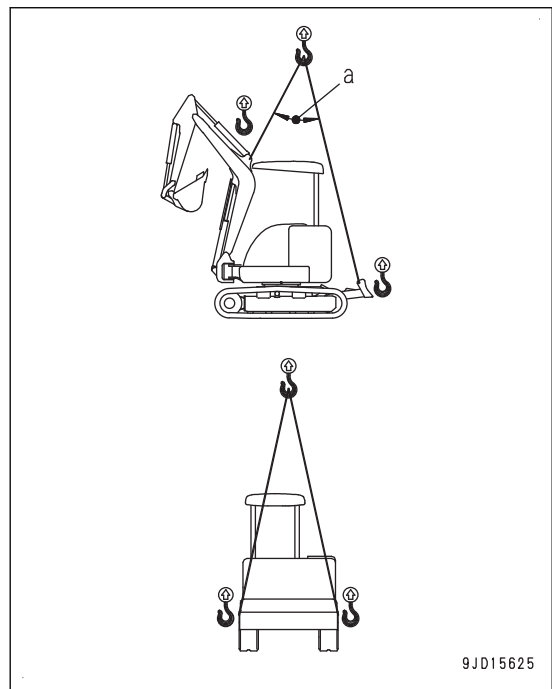

COLD WEATHER OPERATION

COLD WEATHER OPERATION INFORMATION

If the ambient temperature becomes low, it becomes difficult to start the engine, and the coolant may freeze. Follow the instructions described as follows.

FUEL AND LUBRICANTS

Change the fuel and oil with ones of low viscosity for all components.

For the specified density, see "METHOD FOR USING FUEL, COOLANT AND LUBRICANTS ACCORDING TO AMBIENT TEMPERATURE".

COOLANT

WARNING

- **Coolant is toxic. Be careful not to get it into your eyes or on your skin. If it should get into your eyes or on your skin, wash it off with large amount of fresh water and see a doctor immediately.**
- **When handling the cooling water containing coolant that has been drained during changing the coolant or repairing the radiator, contact your Komatsu distributor or request a qualified company to perform the operation.**
Coolant is toxic, so never pour it into drainage ditches or drain it onto the ground surface.

NOTICE

Komatsu recommends the use of Non-Amine Engine Coolant (AF-NAC) as coolant.

Non-Amine Engine Coolant (AF-NAC) is already diluted with distilled water, so it is not flammable.

For the density of Non-Amine Engine Coolant (AF-NAC), see "METHOD FOR USING FUEL, COOLANT AND LUBRICANTS ACCORDING TO AMBIENT TEMPERATURE".

BATTERY

 WARNING

- Do not bring any open flame near the battery. Otherwise, it may explode since the battery generates the flammable gas.
- Battery electrolyte is dangerous object. If it gets in your eyes or on your skin, wash it off with a large amount of water and consult a doctor.
- Battery electrolyte dissolves paint. If it gets on the bodywork, wash it off immediately with water.
- Do not charge the battery or start the engine with a different power source if the battery electrolyte is frozen. Battery may explode.
- Battery electrolyte is toxic. Do not let it flow into drainage ditches or spray it on to the ground surface.

When the ambient temperature drops, the capacity of the battery will also drop. Maintain the battery charging rate as close as possible to 100 %. Insulate it against cold temperature to ensure that the machine can be started easily in the next morning.

REMARK

Measure the gravity of the electrolyte and calculate the charging rate from the following conversion table.

Electrolyte Temperature Charging Rate (%)	20 °C {68 °F}	0 °C {32 °F}	-10 °C {14 °F}	-20 °C {-4 °F}
100	1.28	1.29	1.30	1.31
90	1.26	1.27	1.28	1.29
80	1.24	1.25	1.26	1.27
75	1.23	1.24	1.25	1.26

- When the ambient temperature is low, the capacity of the battery considerably drops. Cover it, or remove it from the machine to place it in the warm place. Restore it again before the operation.
- If the electrolyte level is low, add distilled water in the morning before beginning the work. Do not add water after the day's work to prevent diluted electrolyte in the battery from freezing during the night.

PRECAUTIONS AFTER DAILY WORK COMPLETION IN COLD WEATHER

WARNING

Performing idling of the tracks is dangerous, stay well away from the tracks.

To prevent mud, water, or the undercarriage from freezing and making it impossible for the machine to move on the following morning, observe the following precautions.

- Remove all the mud and water from the machine body. In particular, wipe the hydraulic cylinder rods clean to prevent damage to the seal caused by mud, dirt, or drops of water on the rod from getting inside the seal.
- Place the machine on a firm, dry ground.
If this is impossible, park the machine on boards.
The boards prevent the tracks from freezing to the ground, and allow the machine to move the next morning.
- Open the drain valve and drain any water collected in the fuel system to prevent it from freezing.
- Fill up the fuel tank. This minimizes moisture condensation in the tank when the temperature drops.
- After operation in water or mud, remove water from undercarriage according to the procedure to extend undercarriage service life.
 1. Run the engine at low idle and swing the upper structure 90 ° to bring the work equipment to the side of the track.
 2. Set the machine in the posture shown in the figure.
 - 1) Operate the work equipment control levers, and lower the bucket bottom to the ground.
 - 2) Operate the work equipment control levers slowly, and push the ground with the bucket bottom to raise the track slightly.
 3. Operate the travel lever and perform idle rotation of the track.
 4. Repeat performing steps 1 to 3 for both of the right and left.

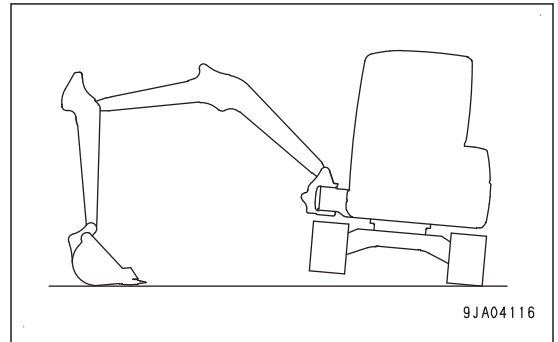

AFTER COLD WEATHER SEASON

When the season changes and the weather becomes warmer, do as follows.

Replace the fuel and oil for all equipment with the ones of the specified viscosity by referring to "METHOD FOR USING FUEL, COOLANT AND LUBRICANTS ACCORDING TO AMBIENT TEMPERATURE".

PRECAUTIONS FOR LONG-TERM STORAGE

PREPARATION FOR LONG-TERM STORAGE

NOTICE

When storing the machine (more than 1 month), set the machine in the posture shown in the figure to protect the hydraulic cylinder piston rods.
 (To prevent the cylinder piston rods from rusting)

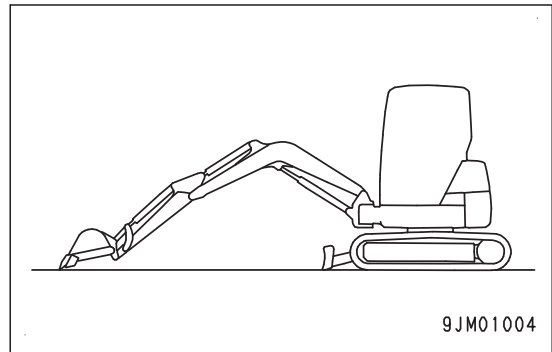

When putting the machine in storage for a long time (more than 1 month), do as follows.

- Clean and wash all the parts of the machine and store it indoors.
 If the machine has to be stored outdoors, select a level ground and cover it with waterproof sheet.
- Fill up the fuel tank.
 This prevents dew condensation.
- Grease the machine and change the oil before storage.
- Coat the exposed portion of the hydraulic cylinder piston rod with grease.
- Disconnect the negative (-) terminal of the battery and cover it or remove it from the machine and store it separately.
 When the machine is equipped with the battery disconnect switch, turn the starting switch to OFF position, and after checking that the system operating lamp is not lit, set the key of the battery disconnect switch (if equipped) to OFF position and pull it out. Cover the battery for storage.
- Fix each control lever and pedal with the lock lever and lock cover.
- Plug the outlets (2 places) of piping for the attachment of the machine ready for installation of attachment.

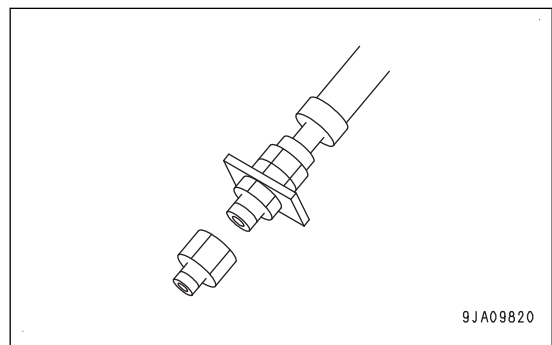

- If the machine is ready for installation of attachment, set the selector valve (1) to "General attachments such as crusher" position (a).
- To prevent rust, fill the cooling circuit with Non-Amine Engine Coolant (AF-NAC) to give a density of 30 % or more for the engine coolant.

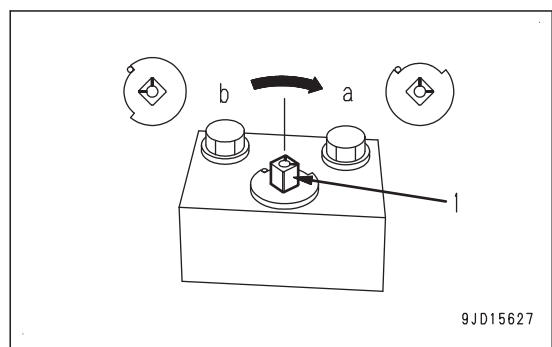

MAINTENANCE DURING LONG-TERM STORAGE

WARNING

If it is necessary to perform the rust-prevention operation while the machine is indoors, open the doors and windows to improve ventilation and prevent gas poisoning.

- During storage, operate and move the machine for a short distance once a month so that a new film of oil will coat moving parts. At the same time, charge the battery as well.
- When operating the work equipment, wipe off all the grease from the hydraulic cylinder rods.
- If the machine is equipped with an air conditioner, operate the air conditioner for 3 to 5 minutes once a month to lubricate all parts of the air conditioner compressor. Always run the engine at low idle when doing this. In addition, check the refrigerant level twice a year.

STARTING MACHINE AFTER LONG-TERM STORAGE

NOTICE

If the machine has been stored without performing the monthly rust-prevention operation, consult your Komatsu distributor before using it.

Perform the following items when using the machine after long-term storage.

- Wipe off the grease from the piston rods of the hydraulic cylinder.
- Add oil and grease at all lubrication points.
- After long-term storage, the moisture in the atmosphere has mixed in the oil, so check the oil in each part before/after starting the engine.
If there is water in the oil, change all the oil.
- Connect the negative (-) terminal after installing the battery or removing the cover.
For machines equipped with a battery disconnect switch (optional), insert the key into the battery disconnect switch (optional) and turn the key to ON position.
- If the machine is stored for a long period with the battery disconnect switch (if equipped) OFF or the battery terminal disconnected, the time information of the clock and radio (if equipped) tuning information may be lost.
In that case, set them again by referring to “CLOCK ADJUSTMENT” and “HANDLE RADIO”.
- When starting the engine, perform the engine warm-up operation thoroughly.

TROUBLES AND ACTIONS

ACTIONS WHEN RUNNING OUT OF FUEL

When starting the engine again after running out of fuel, fill with fuel, and bleed the air from the fuel system before starting the engine.

Always check the fuel level to prevent running out of fuel.

If the engine has stopped due to run out of fuel, all air must be sufficiently bled from the fuel circuit.

PROCEDURES FOR BLEEDING AIR FROM FUEL CIRCUIT

1. Pull engine rear cover (1) toward you to open it.
Open engine rear cover (1) fully and it is secured by rod (2).

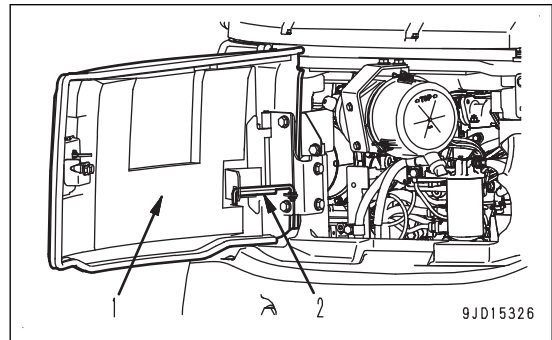

2. Pull cooling cover (3) toward you to open it.

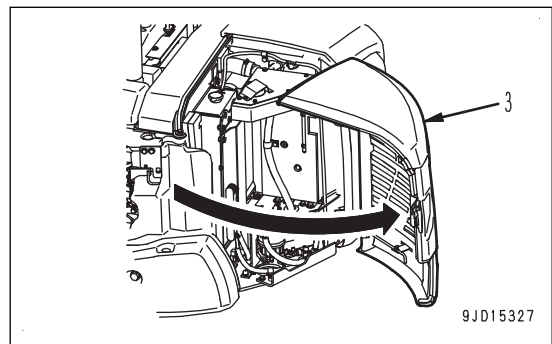

3. Turn rod (4) to LOCK position (L), and fix cooling cover (3) with the rod.

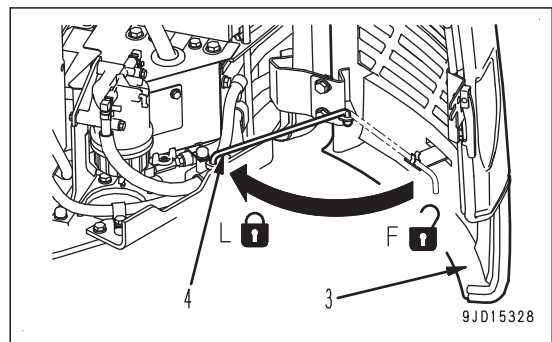

4. Open dirt cover (5).
Open dirt cover (5) fully and it will be secured by cover support lever (6).
5. Fill up the fuel tank with fuel.

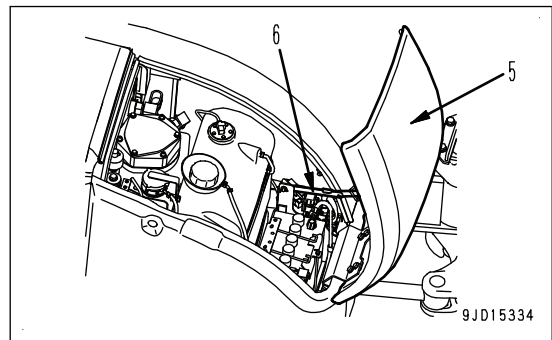

6. Turn handle (8) of fuel prefilter (7) to OPEN position (O).
7. Loosen air bleeding bolt (9) of the fuel prefilter by 2 to 3 turns. When the fuel including no air bubbles comes out from air bleeding bolt (9), tighten air bleeding bolt (9).

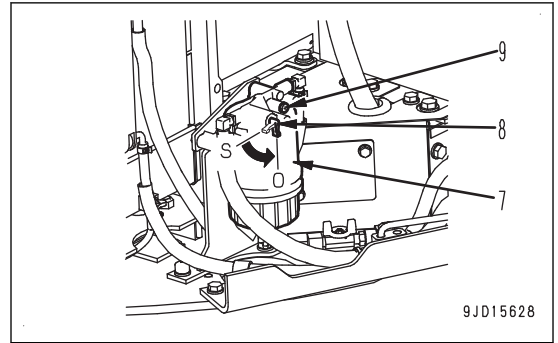

8. Turn the key in starting switch to ON position (B).

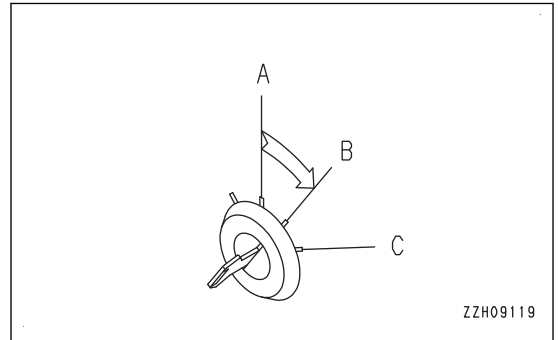

9. 10 to 15 seconds later, return it to OFF position (A).
The air is bled automatically with automatic air bleeding device.
10. Close dirt cover (5).
11. Turn rod (4) to FREE position (F), and close cooling cover (3).
12. Close engine rear cover (1).

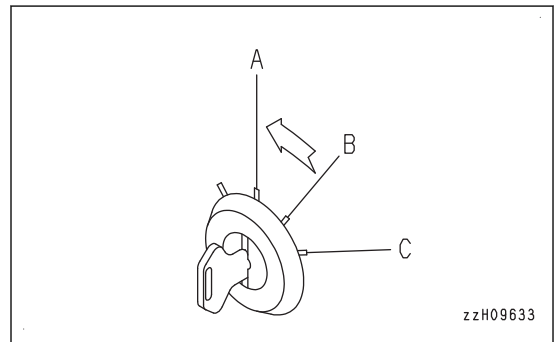

PHENOMENA THAT ARE NOT FAILURES

Note that the following phenomena are not failures:

- When the arm is operated IN from a high position for digging under no load, the arm speed drops momentarily at the vertical position.

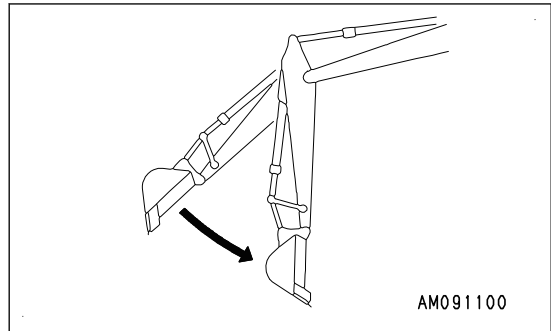

- When performing bucket CURL operation from a high position for digging under no load, the bucket speed drops momentarily at the horizontal position.
- The bucket or arm wobbles by itself during heavy-duty digging operations.

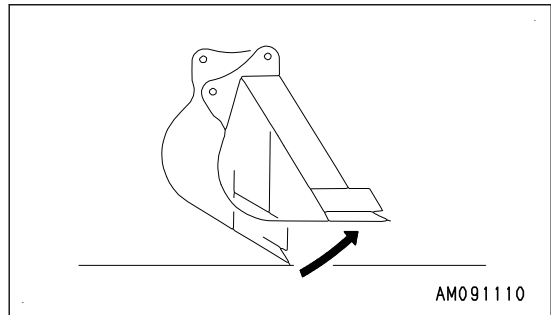

- When starting or stopping the swing, a noise is generated from the brake valve.
- When going down a steep slope at low speed, a noise is generated from the travel motor brake valve.

PRECAUTIONS FOR TOWING MACHINE

WARNING

Always use the correct towing equipment and towing method. Any mistake in the selection of the wire rope or drawbar or the method of towing a disabled machine and being towed may lead to serious personal injury or death.

- Always confirm that the wire rope or drawbar used for towing has ample strength for the weight of the machine being towed.
- Never use the wire rope which has cut strands (A), reduced diameter (B), or kinks (C). There is a danger that the rope may break during the towing operation.
- Always wear leather gloves when handling the wire rope.
- Never tow a machine on a slope.
- During the towing operation, never stand between the towing machine and the towed machine.
- Move the machine slowly and be careful not to apply any sudden load to the wire rope.
- Do not use the holes for towing light objects or tie-down holes when towing the machine.

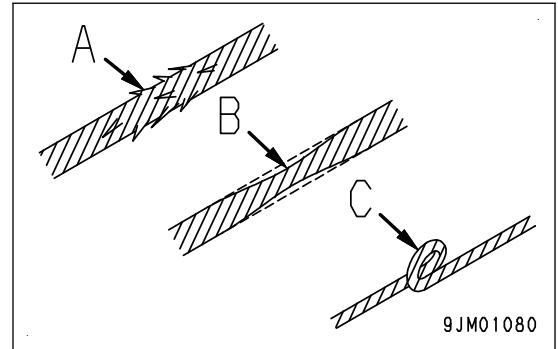

NOTICE

The maximum towing capacity for this machine is 42000 N {4280 kg} .

Do not tow any load greater than this.

- If the machine sinks in mud and cannot get out under its own power, or if the machine tows a heavy object, use a wire rope as shown in the figure.
- Place pieces of wood between the wire ropes and the machine to prevent damage to the ropes and the machine.
- Hold the wire rope level and set it straight to the track frame.
- When towing a machine, travel at a speed of 1 km/h or less {0.62 MPH or less} for a distance of only a few meters to a place that is suitable for performing repairs.

This method is applied only in emergencies.

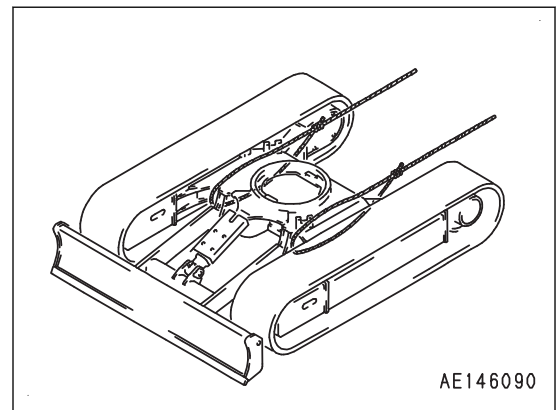

PRECAUTIONS FOR SEVERE JOB CONDITION

- When performing digging operations in water, if the work equipment mounting pin goes into the water, perform greasing every time the operation is performed.
- For heavy-duty operations and deep digging, perform greasing of the work equipment mounting pins every time before operation.
After greasing, operate the boom, arm and bucket several times, then grease again.

PRECAUTIONS FOR DISCHARGED BATTERY

WARNING

- It is dangerous to charge a battery when installed on a machine. Make sure that it is removed before charging.
- When checking or handling the battery, stop the engine and turn the starting switch and battery disconnect switch (if equipped) keys to OFF positions.
- The battery generates hydrogen gas, and it is dangerous that it may explode. Do not bring lighted cigarettes near the battery, and do nothing that will cause sparks.
- Battery electrolyte is dilute sulfuric acid, and it will attack your clothes and skin. If it gets on your clothes or on your skin, immediately wash it off with a large amount of water.
If it gets in your eyes, wash the eyes immediately with water, then consult a doctor for medical treatment.
- When handling batteries, always wear protective eye-glasses and rubber gloves.
- When removing the battery, first disconnect the cable from the ground (normally the negative (-) terminal). When installing, first connect the cable to the positive (+) terminal.
If a tool touches the positive (+) terminal and the chassis, it is dangerous that it may cause a spark. Be extremely careful.
- If the terminals are loose, it is dangerous that the defective contact may generate sparks, and it may cause an explosion.
Install the cable terminals securely.
- When removing or installing the cable terminals, be careful not to mistake the positive (+) terminal for the negative (-) terminal.

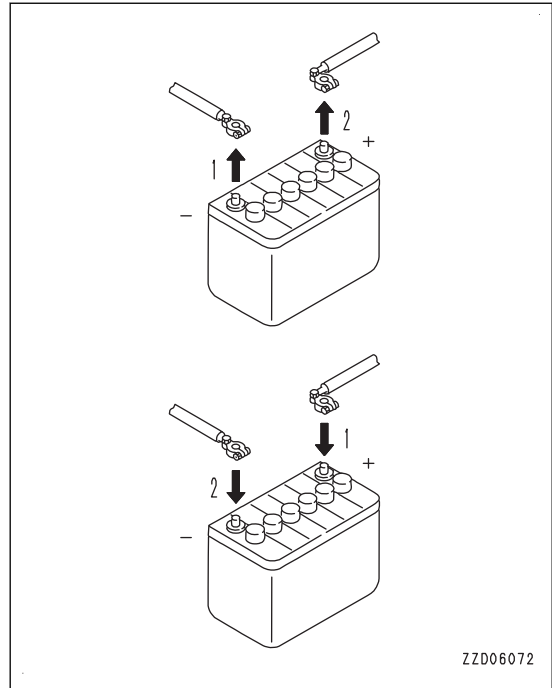

METHOD FOR REMOVING AND INSTALLING BATTERY

⚠ WARNING

Stop the engine, and turn the starting switch and the battery disconnect switch (if equipped) keys to OFF positions when handling the battery.

METHOD FOR REMOVING BATTERY

⚠ CAUTION

Remove the ground cable (normally connected to the negative (-) terminal) first. If any tool touches between the positive (+) terminal and the chassis, there is a hazard of sparks being generated.

NOTICE

Wait for approximately 2 minutes after turning the starting switch to OFF position, and then disconnect the negative (-) terminal. If the negative (-) terminal is removed without waiting for 2 minutes, the data in the controller may be lost.

1. Open dirt cover (1).
Open dirt cover (1) fully and it will be secured by cover support lever (2).
2. Remove the rubber cover on the battery.
3. Remove the cable on the negative (-) terminal side (ground side) first.
4. Remove the connecting cable on the positive (+) terminal side.
5. Remove mounting nut (3) and remove battery mounting hardware (4).
6. Take the battery out of the machine.

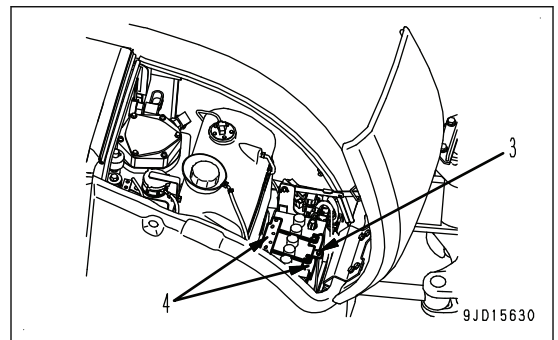
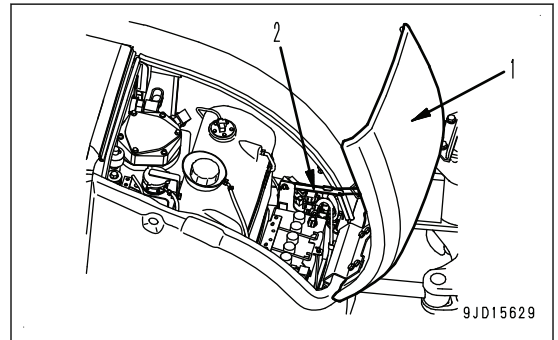

METHOD FOR INSTALLING BATTERY

CAUTION

- When installing the battery, connect the ground cable last.
- When replacing the battery, secure the battery body with the battery mounting hardware.
- To prevent a fire, install the rubber cover above the battery so that it envelops the battery and it is not flipped.
Replace the rubber cover immediately if the rubber cover is damaged.
- If chloride is accumulated on the top surface of battery and around terminals, clean them with approximately 40 °C {104 °F} of warm water and dry them thoroughly, and then connect the battery cable to them.

NOTICE

After securing the battery, check that it does not move.
If it moves, tighten it again securely.

1. Place the battery in the specified position.
If chloride is accumulated on the top surface of battery and around terminals, clean them with approximately 40 °C {104 °F} of warm water and dry them thoroughly.
2. Fix the battery securely with mounting nut (3) and battery mounting hardware (4).
Allowable tightening torque: 3.2 to 5.2 Nm {0.33 to 0.53 kgm, 2.39 to 3.83 lbft}
3. Install the connecting cable on the positive (+) terminal side.
Connect positive (+) terminal side first.
4. Install the cable on the negative (-) terminal side (ground side).
5. Cover the top surface of the battery with the rubber cover.
Install the rubber cover so that it is not flipped.
If the rubber cover is damaged, replace it immediately.
6. Close dirt cover (1).

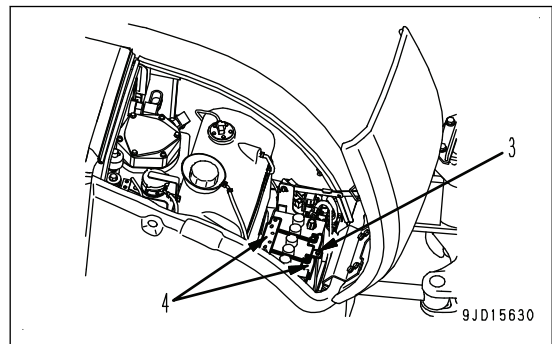

PRECAUTIONS FOR CHARGING BATTERY**⚠ WARNING**

When charging the battery, if the battery is not handled correctly, there is a danger that the battery may explode. Follow the instruction manual accompanying the battery charger, and observe the following.

- Set the voltage of the charger to match the voltage of the battery to be charged. If the correct voltage is not selected, the battery charger may overheat and cause an explosion.
- Connect the positive (+) charger clip of the battery charger to the positive (+) terminal of the battery, then connect the negative (-) charger clip of the battery charger to the negative (-) terminal of the battery. Be sure to attach the clips securely.
- Set the charging current to 1/10 or less of the value of the rated battery capacity. When performing rapid charging, set it to less than the rated battery capacity. If the charger current is too high, the electrolyte will leak or the battery cells will dry up, and this may cause the battery to catch fire and explode.
- Do not charge the battery or start the engine with a different power source if the battery electrolyte is frozen. This may ignite the battery electrolyte, and battery may explode.
- Do not use or charge the battery if the battery electrolyte level is below LOWER LEVEL line. This may cause an explosion. Check the battery electrolyte level periodically and add the purified water (such as a commercial battery fluid) to bring the electrolyte level to UPPER LEVEL line.

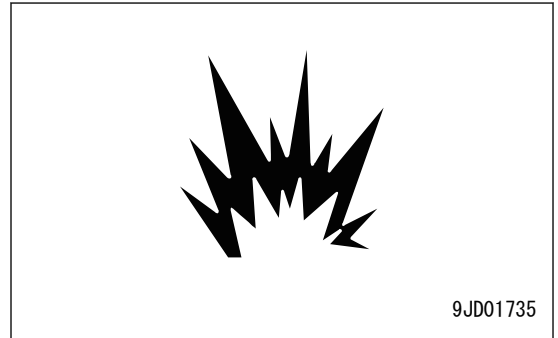

START ENGINE WITH JUMPER CABLES

WARNING

- Never contact the positive (+) terminal and negative (-) terminal when connecting the cables.
- Always wear protective eyeglasses and rubber gloves when starting the engine by using the jumper cable.
- Do not bring the normal machine into contact with the failed machine.
Spark may occur near the battery which generates the hydrogen gas, and it may explode.
- Connect the correct jumper cables correctly.
In the last connection (to the upper structure frame), a spark will be caused, connect the cable to a spot as far away from the battery as possible.
(However, do not connect to the work equipment since the current does not flow well through it.)
- Do not bring the clips in contact with other clips or with the machine when disconnecting the jumper cable.

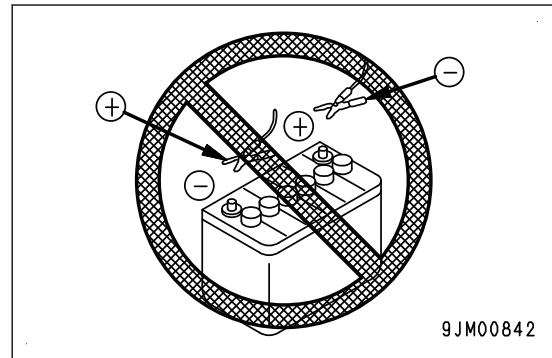

NOTICE

- The sizes of the jumper cables and clips should be suitable for the battery size.
- The battery of the normal machine must be the same capacity as that of the failed machine.
- Check the cables and clips for damage or corrosion.
- Firmly connect the cables and clips.
- Check that the lock levers and parking brake levers (if equipped) of both machines are in LOCK position.
- Control levers must be in NEUTRAL position.
- To prevent damage of the electric devices of the failed machine, turn the starting switch of the failed machine to OFF position, and then turn the battery disconnect switch key (if equipped) to OFF position before connecting the jumper cables.

PROCEDURE FOR CONNECTING JUMPER CABLES

Turn the starting switch and battery disconnect switch (if equipped) of the failed machine, and the starting switch of the normal machine to OFF position.

1. Connect the clip of jumper cable (A) to the positive (+) terminal of battery (C) on the failed machine.
2. Connect the clip at the other end of jumper cable (A) to the positive (+) terminal of battery (D) on the normal machine.
3. Connect the clip of jumper cable (B) to the negative (-) terminal of battery (D) on the normal machine.
 - For machines equipped with a battery disconnect switch (optional), set the battery disconnect switch (optional) of the failed machine to ON position.
4. Connect the other clip of jumper cable (B) to the revolving frame (E) of the failed machine.

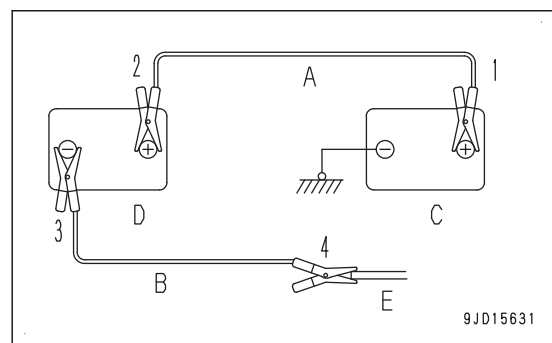

METHOD FOR STARTING ENGINE

1. Check both of normal machine and failed machine that the lock lever is set to LOCK position.
Check also that all the control levers are in NEUTRAL position.
2. Make sure the clips are firmly connected to the battery terminals.
3. Start the engine of the normal machine and run it at high idle (max. speed).
4. Turn the starting switch of the failed machine to START position and start the engine.
If the engine does not start, try again after at least 2 minutes.

PROCEDURE FOR DISCONNECTING JUMPER CABLES

After the engine has started, disconnect the jumper cables in the reverse of the order in which they were connected.

1. Remove the clip of jumper cable (B) from revolving frame (E) of upper structure of the failed machine.
2. Remove the clip of jumper cable (B) from the negative (-) terminal of battery (D) on the normal machine.
3. Remove the clip of jumper cable (A) from the positive (+) terminal of battery (D) on the normal machine.
4. Remove the clip of jumper cable (A) from the positive (+) terminal of battery (C) on the failed machine.

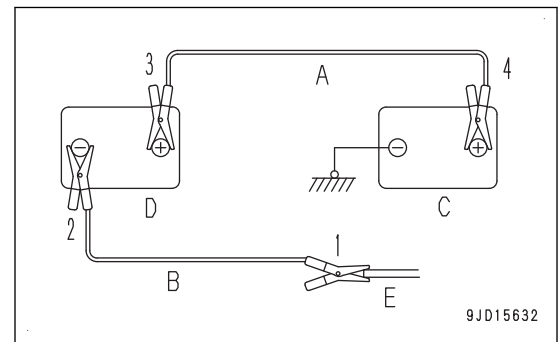

OTHER TROUBLE

PHENOMENA AND ACTIONS FOR ELECTRICAL SYSTEM

- For the remedies indicated with (*) in the remedy column, always contact your Komatsu distributor.
- In cases of problems or causes which are not listed below, ask your Komatsu distributor for repairs.

Problem	Main causes	Remedy
Lamp does not glow brightly even when the engine runs at high speeds.	Defective wiring	Check and repair loose terminals, open circuit. (*)
	Loose fan belt	Adjust fan belt tension. See EVERY 500 HOURS MAINTENANCE.
	Blown fuse	Replace
Lamp flickers while engine is running.	Defective wiring	Check and repair loose terminals, open circuit. (*)
	Loose fan belt	Adjust fan belt tension. See EVERY 500 HOURS MAINTENANCE.
	Blown fuse	Replace
Charge level caution lamp does not go out even when engine is running.	Defective alternator	Replace. (*)
	Defective wiring	Check, repair. (*)
Unusual noise is generated from alternator	Defective alternator	Replace. (*)
Starting motor does not rotate even when starting switch is turned to START position.	Defective wiring	Check, repair. (*)
	Insufficient battery charge	Charge battery.
	Blown fuse	Replace
	Battery disconnect switch (if equipped) is at OFF position	Turn it to ON position.
	Engine shutdown secondary switch is at "ENGINE STOP" position	Set it to "NORMAL" position and close the cover.
	Lock lever is in FREE position	Set the lock lever to LOCK position.
Pinion of starting motor repeats engaging and disengaging (rattles).	Insufficient battery charge	Charge battery.
Starting motor turns engine sluggishly.	Insufficient battery charge	Charge battery.
	Defective starting motor	Replace. (*)
Starting motor disengages before engine starts.	Defective wiring	Check, repair. (*)
	Insufficient battery charge	Charge battery.
Preheating pilot lamp does not light up.	Defective wiring	Check, repair. (*)
Oil pressure caution lamp does not light up when engine is stopped (starting switch is at ON position).	Defective caution lamp	Replace. (*)
	Defective oil pressure switch	Replace. (*)

PHENOMENA AND ACTIONS FOR CHASSIS

- In cases of problems or causes which are not listed below, ask your Komatsu distributor for repairs.

Problem	Main causes	Remedy
Speed of travel, swing, boom, arm, bucket is slow	Lack of hydraulic oil	Set oil to specified level. See CHECKS BEFORE STARTING.
Pump generates unusual noise.	Clogged element in hydraulic tank strainer	Clean. See EVERY 2000 HOURS MAINTENANCE.
Excessive rise in hydraulic oil temperature	Lack of hydraulic oil	Set oil to specified level. See CHECKS BEFORE STARTING.
	Loose fan belt	Adjust fan belt tension. See EVERY 500 HOURS MAINTENANCE.
	Clogged radiator fins and oil cooler fins	Clean or repair. See EVERY 500 HOURS MAINTENANCE.
Track comes off.	Track too loose	Adjust track tension. See WHEN REQUIRED.
Abnormal wear of sprocket	Track too loose	Adjust track tension. See WHEN REQUIRED.

PHENOMENA AND ACTIONS FOR ENGINE RELATED PARTS

- For the remedies indicated with (*) in the remedy column, always contact your Komatsu distributor.
- In cases of problems or causes which are not listed below, ask your Komatsu distributor for repairs.

Problem	Main causes	Remedy
Engine oil pressure caution lamp is lit. (Buzzer sounds at the same time.)	Insufficient oil in engine oil pan (sucking in air)	Set oil to specified level. See CHECKS BEFORE STARTING.
	Clogged oil filter cartridge	Replace cartridge. See EVERY 500 HOURS MAINTENANCE.
	Oil leakage due to defective tightening or breakage of oil pipe or pipe joint.	Check, repair. (*)
	Engine oil pressure switch error	Replace switch (*)
Steam spurts out from top of radiator (pressure valve).	Lowered coolant level, leakage of coolant	Check, add coolant, repair. See CHECKS BEFORE STARTING.
	Loose fan belt	Adjust fan belt tension. See EVERY 500 HOURS MAINTENANCE.
	Accumulation of dirt or scale in cooling system	Change coolant, flush inside of cooling system. See WHEN REQUIRED.
	Clogged radiator fins or damaged fin	Clean or repair. See EVERY 500 HOURS MAINTENANCE.
	Defective thermostat	Replace thermostat. (*)
	Loose radiator filler cap (in high altitude operation)	Tighten cap or replace packing.
The graduation of engine coolant temperature gauge indicates red range. (Caution lamp lights up and alarm buzzer sounds at the same time.)	Lowered coolant level, leakage of coolant	Check, add coolant, repair. See CHECKS BEFORE STARTING.
	Loose fan belt	Adjust fan belt tension. See EVERY 500 HOURS MAINTENANCE.
	Accumulation of dirt or scale in cooling system	Change coolant, flush inside of cooling system. See WHEN REQUIRED.
	Clogged radiator fins or damaged fin	Clean or repair. See EVERY 500 HOURS MAINTENANCE.
	Defective thermostat	Replace thermostat. (*)
	Loose radiator filler cap (in high altitude operation)	Tighten cap or replace packing.
The graduation of the engine coolant temperature gauge does not enter the correct range even after the machine has been operated for a long time.	Defective thermostat	Replace thermostat. (*)

Problem	Main causes	Remedy
Starting motor operates but engine does not start.	Lack of fuel	Add fuel. See CHECKS BEFORE STARTING.
	Air in fuel system	Bleed air. See EVERY 500 HOURS MAINTENANCE.
	Water in fuel system	Drain the entrained water. See WHEN REQUIRED, and CHECKS BEFORE STARTING.
	Defective fuel injection pump or defective nozzle	Replace pump or nozzle (*)
	Starting motor cranks engine sluggishly	See ELECTRIC PARTS, "Starting motor cranks engine sluggishly".
	Preheating pilot lamp does not light up.	See ELECTRIC PARTS, "Preheating pilot lamp does not light up".
	Defective compression (Incorrect valve clearance)	Adjust valve clearance. (*)
Exhaust gas color is white or bluish.	Excessive oil in oil pan	Set oil to specified level. See CHECKS BEFORE STARTING.
	Improper fuel	Replace with specified fuel.
Exhaust gas turns black from time to time.	Clogged air cleaner element	Clean or replace. See WHEN REQUIRED.
	Defective nozzle	Replace nozzle. (*)
	Defective compression	Adjust valve clearance. (*)
Combustion makes breathing sound from time to time.	Defective nozzle	Replace nozzle. (*)
Abnormal noise is generated. (Combustion or mechanical)	Low grade fuel being used	Replace with specified fuel.
	Overheating	See the preceding section on "The graduation of engine coolant temperature gauge indicates red range".
	KDPF broken internally	Replace KDPF. (*)
	Excessive valve clearance	Adjust valve clearance. (*)

IF MACHINE MONITOR SHOWS WARNING DISPLAY

When the action level display (1) or caution lamp (2) is displayed on the machine monitor, press the function switch “F3” to display “Current Abnormality” screen and check the details and remedy.

Take the actions according to the message shown on the machine monitor, and check the failure code, and then ask your Komatsu distributor for repair, as necessary.

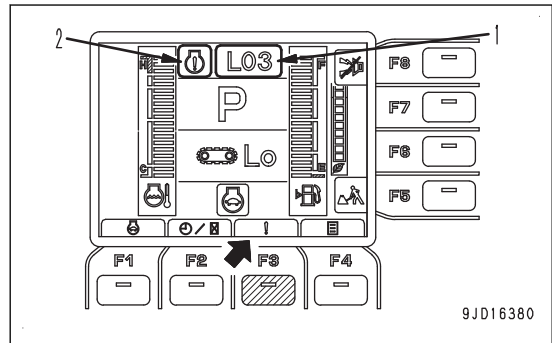

When “DXA8KA” or “DXA8KB” is on “Current Abnormality” screen, turning the pump secondary drive switch to upper (emergency) position enables operations temporarily.

For details of the pump secondary drive switch, see “PUMP SECONDARY DRIVE SWITCH”.

Immediately ask your Komatsu distributor for an inspection and repair after the operation.

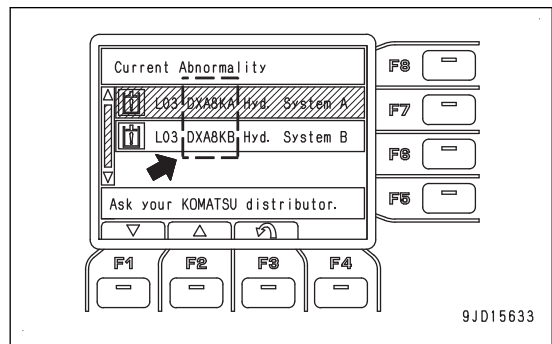

Telephone number for the point of contact if an error occurs

When an error screen is displayed on the machine monitor, press the function switch “F3” to display “Current Abnormality” screen, and the telephone number (3) for the point of contact is displayed in the message column at the bottom of the screen.

REMARK

If no point of contact telephone number is registered, no telephone number is displayed.

Ask your Komatsu distributor for the telephone number registration if necessary.

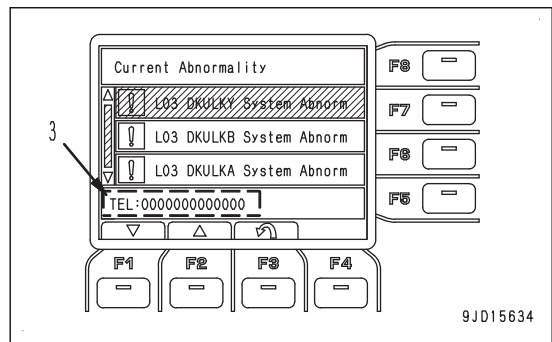

MAINTENANCE

WARNING

Please read and make sure that you understand the SAFETY section before reading this section.

PRECAUTIONS FOR MAINTENANCE

Do not perform any inspection and maintenance operation that are not found in this manual.

CHECK SERVICE METER READING

Check the service meter reading every day to see if the maintenance time has come for any necessary maintenance item to be performed.

KOMATSU GENUINE REPLACEMENT PARTS

Komatsu recommends using Komatsu genuine parts specified in Parts Book as replacement parts.

KOMATSU GENUINE LUBRICANTS

For lubrication of the machine, Komatsu recommends using Komatsu genuine lubricants. Moreover use oil of the specified viscosity according to the ambient temperature.

ALWAYS USE CLEAN WASHER FLUID

Use automobile window washer fluid, and be careful not to let any dirt get into it.

FRESH AND CLEAN LUBRICANTS

Use clean oil and grease. Also, keep the containers of the oil and grease clean. Keep foreign materials away from oil and grease.

CHECK DRAINED OIL AND USED FILTER

At the replacement of the filters when oil is changed, check the old oil and filters for metal particles and foreign materials. If large quantity of metal particles or foreign materials are found, always report to the person in charge, and perform suitable action.

PRECAUTIONS FOR REFILLING OIL OR FUEL

If your machine is equipped with a strainer, do not remove it while filling oil or fuel.

PRECAUTIONS FOR WELDING

- When conducting welding repair, turn the starting switch to OFF position, and wait for approximately 2 minute, and then disconnect the negative (-) terminal of the battery.
- Do not apply a voltage of 200 V and above continuously.
- Connect grounding cable within 1 m {within 3 ft 3 in} of the area to be welded. If grounding cable is connected near instruments, connectors, etc., the instruments may malfunction.
- Prevent seals, bearings or bushings from entering the space between the welding part and grounding part. Sparks generated there can damage the seals.
- Do not use the area around the work equipment pins or the hydraulic cylinders as the grounding point. Sparks generated there can damage the plated part.

DO NOT DROP THINGS INSIDE MACHINE

- When opening the inspection windows or the oil filler port of the tank to perform inspection, be careful not to drop nuts, bolts, or tools inside the machine.
If such things are dropped inside the machine, it may cause damage and/or malfunction of the machine, and will lead to failure. If anything drops, be sure to take it out.
- Do not put unnecessary things in your pockets. Carry only things which are necessary for inspection.

PRECAUTIONS FOR KDPF

When performing inspection and maintenance during or just after regeneration, take care of the high temperature parts.

Even after the engine stops the parts around KDPF may be at high temperature.

DUSTY JOBSITES

When working at dusty jobsites, observe the following.

- Inspect the dust indicator frequently to see if the air cleaner is dirty or clogged.
- Clean the radiator core frequently to avoid clogging.
- Clean and replace the fuel filter frequently.
- Clean electrical components, especially the starting motor and alternator, to avoid accumulation of dust.
- When checking and replacing the oil or filters, move the machine to a place where there is no dust and take care to prevent dust from entering the system.

AVOID MIXING OIL

Never mix different brand or grade of oil. If a different brand or grade of oil has to be added, drain the old oil and replace all the oil with the new brand or grade of oil.

LOCK INSPECTION COVERS

Lock inspection cover securely into position with the lock bar, etc. If inspection or maintenance is performed with inspection cover not locked in position, there is a danger that it may be suddenly shut by the wind and cause personal injury.

PRECAUTIONS WHEN SWINGING BOOM

When the mud cover at the right side of machine is opened for inspection and maintenance, if you swing the boom to right, do it with the dirt cover opened half way.

If the dirt cover is fully opened, it may interfere with the boom and be damaged.

PRECAUTIONS WHEN OPENING AND CLOSING COOLING COVER

If the cooling cover at the right side of machine is fully opened with the blade raised, the cooling cover may interfere with the blade and be damaged.

When the cooling cover is opened for testing or maintenance, etc., lower the blade to the ground or bring the blade to the opposite side of the cooling cover.

BLEED AIR FROM HYDRAULIC CIRCUIT

When hydraulic equipment is repaired or replaced, or the hydraulic piping is disconnected, the air must be bled from the circuit.

PRECAUTIONS WHEN INSTALLING HYDRAULIC HOSES

- When removing parts at locations where there are O-rings or gasket seals, clean the mounting surface, and replace them with new parts.
When doing this, be careful not to forget to assemble O-rings and gaskets.
- When installing the hoses, do not twist them or bend them sharply.
If they are installed so, their service life will be extremely shortened and they may be damaged.

CHECKS AFTER INSPECTION AND MAINTENANCE

If you forget to perform the inspection and maintenance, unexpected problems may occur, and this may lead to personal injury. Always observe the following.

Checks after operation (with engine stopped)

- Have any inspection and maintenance points been forgotten?
- Have all inspection and maintenance items been performed correctly?
- Have any tools or parts been dropped inside the machine? It is particularly dangerous if parts are dropped inside the machine and get caught in the lever linkage mechanism.
- Are there any leakage of coolant or oil? Have all nuts and bolts been tightened?

Checks while the engine is running

- For the checks when the engine is running, see SAFETY, “TWO WORKERS FOR MAINTENANCE WHEN ENGINE IS RUNNING” and pay attention to safety.
- Increase the engine speed to check for the leakage of fuel or oil.
- Check if the inspected and serviced area is normally operated.

FIX FLOOR SECURELY

After opening or closing the floor for the inspection and maintenance, fix the floor with the floor tilt lock bolt securely. If it is not securely fixed, it may lead to a serious personal injury or death.

FUEL AND LUBRICANTS TO MATCH THE AMBIENT TEMPERATURE

It is necessary to select fuel or lubricant according to the ambient temperature.

OUTLINE OF MAINTENANCE

- Komatsu recommends using Komatsu genuine parts for replacement parts, grease or oil.
- When changing the oil or adding oil, do not mix different types of oil. When changing the type of oil, drain all the old oil and fill completely with the new oil. Always replace the filter at the same time. (There is no problem if the small amount of oil remaining in the piping mixes with the new oil.)
- Unless otherwise specified, when the machine is shipped from the plant, it is filled with the oil and coolant listed in the table below.

Item	Type
Engine oil pan	Engine oil EO10W30-LA (Komatsu genuine)
Final drive case	Power train oil TO30 (Komatsu genuine)
Hydraulic oil system (Use for swing machinery case as well.)	Hydraulic oil HO56-HE (Komatsu genuine)
Radiator	Non-Amine Engine Coolant (AF-NAC) (Komatsu genuine) (density 30 % and above)

HANDLE OIL, FUEL, COOLANT, AND PERFORMING OIL CLINIC

OIL

- Oil is used in the engine and hydraulic equipment under extremely severe conditions (high temperature, high pressure), and deteriorates with use.
Always use oil that matches the grade and maximum and minimum ambient temperatures recommended in Operation and Maintenance Manual.
Even if the oil is not dirty, always change the oil at the specified interval.
- Oil corresponds to blood in the human body, always be careful when handling it to prevent any impurities (water, metal particles, dirt, etc.) from getting in.
The majority of failures with the machine are caused by the entry of such impurities.
Take particular care not to let any impurities get in when storing or adding oil.
- Never mix oils of different grades or brands.
- Always add the specified amount of oil.
Having too much oil or too little oil are both causes of failures.
- If the oil in the work equipment is not clear, there is probably water or air getting into the circuit. In such cases, consult your Komatsu distributor.
- When changing the oil, always replace the related filters at the same time.
- We recommend that you have an oil analysis periodically to check the condition of the machine. For those who wish to use this service, consult your Komatsu distributor.
- When using commercially available oil, it may be necessary to reduce the oil change interval. We recommend that you use the Komatsu oil clinic to check the characteristics of the oil in detail.

NOTICE

Komatsu recommends using Komatsu genuine engine oil for KDPF. If engine oil other than Komatsu genuine oil for KDPF is used, it may shorten cleaning interval of KDPF filters, adversely affect the engine such as deteriorated oil may reduce lubricating function, and it may cause failure, shortening of the machine life, lowering of performance and increase of fuel consumption.

FUEL

- To prevent the moisture in the air from condensing and forming water inside the fuel tank, always fill the fuel tank with fuel after completing the day's work.
- The fuel pump is a precision equipment, and if fuel containing water or dirt is used, it cannot work properly.
- Be extremely careful not to let impurities get in when storing or adding fuel.
- Always use the fuel specified for the temperature that is described in Operation and Maintenance Manual.
 - If the fuel is used at the temperatures lower than the operating temperature (particularly at temperatures below $-15\text{ }^{\circ}\text{C}$ { $5\text{ }^{\circ}\text{F}$ }), the fuel will solidify.
 - If the fuel is used at temperatures higher than the operating temperature, the viscosity will drop, and it may result in troubles such as a drop of output.
- Before starting the engine, or after 10 minutes of adding fuel, drain the sediment and water from the fuel tank.
- If the engine runs out of fuel, or if the filters are replaced, it is necessary to bleed the air from the circuit.
- If there is any foreign material in the fuel tank, wash the tank and fuel system.

NOTICE

The fuel used must be ultra low-sulfur diesel fuel.

To ensure good fuel consumption characteristics and exhaust gas characteristics, the engine mounted on this machine uses an electronically controlled high-pressure fuel injection device and emission gas control system (KDPF). Since the high-pressure fuel injection device requires high precision parts and lubrication, if low viscosity fuel with low lubricating ability is used, its durability may drop considerably. And using fuel with high sulfur content can deteriorate the engine parts and KDPF catalyzer, inducing failures, decrease of the life and degradation in performance.

The ASTM diesel fuel recommended by Komatsu may contain 5 % or less of biofuel. The EN diesel fuel may contain 7 % or less of it. Use the fuel which is filled into the storage tank or the fuel tank of the machine as soon as possible.

When the diesel fuel is changed to the one mixed with the bio-fuel, replace the fuel prefilter cartridge and the fuel main filter cartridge with new ones.

COOLANT AND WATER FOR DILUTION

- The coolant has the important function of preventing corrosion as well as preventing freezing. Even in the areas where freezing is not an issue, the use of coolant is essential. Komatsu machines are supplied with Non-Amine Engine Coolant (AF-NAC). Non-Amine Engine Coolant (AF-NAC) has excellent anti-corrosion, antifreeze and cooling properties and can be used continuously for 2 years or 4000 hours. Komatsu recommends the use of Non-Amine Engine Coolant (AF-NAC). If you use another coolant, it may cause serious problems, such as corrosion of the engine and aluminum parts of the cooling system.
- When using antifreeze, always observe the precautions given in Operation and Maintenance Manual.
- Non-Amine Engine Coolant (AF-NAC) is already diluted with distilled water, so it is not flammable.
- The coolant density needs to be changed in accordance with the ambient temperature. Even in areas where it is not considered necessary to prevent freezing, always use Non-Amine Engine Coolant (AF-NAC) with a density of 30 % or more in order to prevent corrosion of the cooling system. Non-Amine Engine Coolant (AF-NAC) is diluted with distilled water that does not contain any ions or water-hardening substances. Never dilute it with water.
- If the engine overheats, wait for the engine to cool down before adding coolant.
- If the coolant level is low, it will cause overheating, and will also cause problems with corrosion due to air entering the coolant.

GREASE

- Grease is used to prevent seizure and noises at the joints.
- This construction equipment is used under heavy-duty conditions. Komatsu recommends using the recommended grease and follow the replacement intervals and recommended ambient temperatures given in this Operation and Maintenance Manual.
- If the grease fitting which is not described in the periodic maintenance section becomes stiff, or it creaks after being used for long time, add grease according to the description of WHEN REQUIRED.
- Always wipe off all of the old grease that is pushed out when greasing.
Be particularly careful to wipe off the old grease in places where sand or dirt sticking in the grease would cause wear of the rotating parts.

PERFORM KOWA (Komatsu Oil Wear Analysis)

KOWA is a maintenance service that makes it possible to prevent machine failures and downtime. With KOWA, the oil is periodically sampled and analyzed. This enables early detection of wear of the machine drive parts and other problems.

Thanks to long term experience and ample data accumulated, we can grasp condition of your machine accurately and provide proper recommendation.

We strongly recommend you to use this service. The oil analysis is performed at actual cost, so the cost is low, and results of the analysis and recommendations are reported promptly.

KOWA analysis items

Measurement of metallic powder concentration

An ICP (Inductively Coupled Plasma) analyzer is used for measuring the concentration of iron, copper, and other metal powder in the oil.

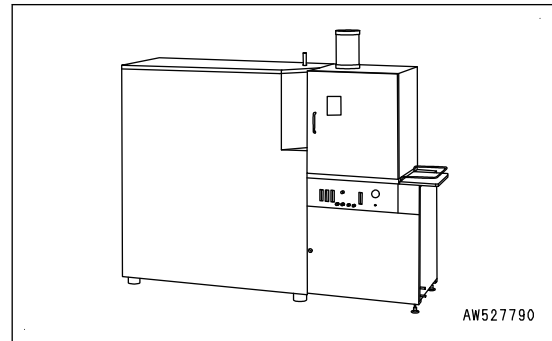

Measurement of quantity of iron particles

A PQI (Particle Quantifier Index) measuring instrument is used for measuring the quantity of iron particles of 5 μm or more, enabling early detection of failures.

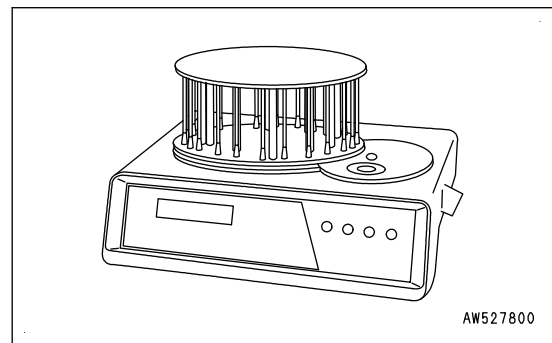

Others

Measurements are made of items such as the ratio of water, coolant, and fuel in the oil, and dynamic viscosity, if necessary, to enable a highly precise diagnosis of the machine and the components' condition.

Oil sampling interval

500 hours

Precautions when sampling

- Make sure that the oil is well mixed before sampling.
- Perform sampling at regular fixed intervals.
- Do not perform sampling on rainy or windy days when water or dust can get into the oil.

For further details of KOWA, contact your Komatsu distributor.

STORE OIL AND FUEL

- Keep oil and fuel indoors to prevent any water, dirt, or other impurities from getting in.
- When keeping drum cans for a long period, lay the drums so that the filler ports of the drums are located in the lower part of the side to prevent moisture from being sucked in. If drums have to be stored outside, cover them with a waterproof sheet or take other measures to protect them.
- To prevent any change in quality during long-term storage, be sure to use in the order of first in - first out (use the oldest oil or fuel first).

FILTER

- Filters are extremely important safety parts. They prevent impurities in the oil, fuel, and air circuits from entering important equipment and causing problems. Replace all filters periodically. For details, see Operation and Maintenance Manual.
However, when working in severe conditions, replace the filters at shorter intervals according to the oil and fuel (sulfur content) being used.
- Never try to clean and use again the filters (cartridge type). Always replace them with new filters.
- When replacing oil filters, check if any metal particles are attached to the old filters.
If any metal particles are found, consult your Komatsu distributor.
- Do not open packages of spare filters until just before they are to be used.
- Komatsu recommends using Komatsu genuine filters.

HANDLE ELECTRICAL COMPONENTS

WARNING

- **When the battery disconnect switch key (if equipped) is turned to OFF position for the maintenance work, always pull out the key and keep it with you.
If the key is left in the switch, someone may turn on the power by mistake. It is dangerous that causes an electric shock.**
- **It is extremely dangerous if the electrical component becomes wet or the covering of the wiring is damaged. This will cause an electrical leakage and may lead to malfunction of the machine.
Do not wash the inside of the operator's compartment with water.
When washing the machine, be careful not to let water get into the electrical components.**

- When removing the connectors of electrical components after washing the machine or in the rain, wipe off the water drop stuck around connectors before removing the connectors and keep the water drop away from inside of the connectors.
- Checking and maintenance items are checking fan belt tension, checking damage of the fan belt and checking battery fluid level.
- Komatsu recommends installing electric components specified by Komatsu.
- External electro-magnetic interference may cause malfunction of the control system controller. Accordingly, consult your Komatsu distributor before installing a radio receiver or other wireless equipment to the machine.
- When working at the seashore, keep the electrical component clean to prevent corrosion.
- When installing electrical component, connect it to the special power supply connector.
Do not connect the optional power supply to the fuse or starting switch or battery relay, etc.

HANDLE HYDRAULIC COMPONENTS

- The hydraulic system is at high temperature during and just after operation. During operations, it is also under high pressure, so when performing inspection and maintenance of hydraulic related equipment, be careful of the following points.
- Stop the machine on a flat ground, lower the bucket to the ground, and perform the work so that there is no pressure on the cylinder circuits.
- Always stop the engine.
- Immediately after stopping operations, the hydraulic oil and lubricating oil is at high temperature and high pressure, so wait for the oil temperature to go down before starting maintenance.
- Even after the temperature has gone down, some parts may still be under internal pressure, so when loosening plugs, bolts, or hose connections, do not stand directly in front of the parts, and loosen slowly to release the internal pressure before removing.
- When performing inspection and maintenance of the hydraulic circuit, always release the air in the hydraulic tank to remove the internal pressure.
- The inspection and maintenance include check of the hydraulic oil level, replacement of filters, changing of the hydraulic oil.
- When high-pressure hoses have been removed, check that there is no damage to O-rings. If any damage is found, replace O-ring.
- When the hydraulic oil filter element or strainer is replaced or cleaned, or when a hydraulic component is repaired, replaced, or its piping is removed, air in the circuit must be bled.

STANDARD TIGHTENING TORQUE FOR BOLTS AND NUTS

Tightening torque list

⚠ CAUTION

If nuts, bolts, or other parts are not tightened to the specified torque, it will cause looseness or damage to the tightened parts, and this will cause failure of the machine or problems with operation. Always be careful when tightening parts.

Unless otherwise specified, tighten the metric nuts and bolts to the torque shown in the table below.

If it is necessary to replace any nut or bolt, Komatsu recommends using Komatsu genuine part of the same size as the part that is removed.

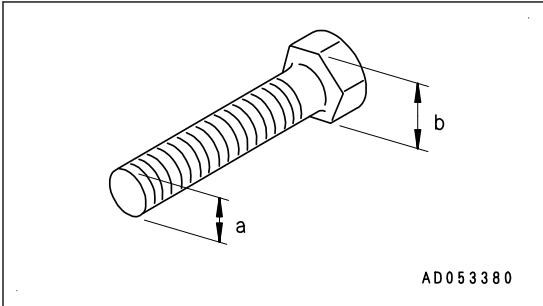

Thread diameter of bolt "a" (mm)	Width across flats "b" (mm)	Tightening torque					
		Target value			Allowable range		
		Nm	kgm	lbft	Nm	kgm	lbft
6	10	13.3	1.35	9.8	11.8 to 14.7	1.2 to 1.5	8.7 to 10.8
8	13	31	3.2	22.8	27 to 34	2.8 to 3.5	20.3 to 25.3
10	17	67	6.8	48.8	59 to 74	6 to 7.5	43.4 to 54.2
12	19	111	11.3	81.4	98 to 123	10 to 12.5	72.3 to 90.4
14	22	172	17.5	127	153 to 190	15.5 to 19.5	112 to 141
16	24	260	26.5	192	235 to 285	23.5 to 29.5	170 to 213
18	27	360	37	268	320 to 400	33 to 41	239 to 297
20	30	510	52.3	378	455 to 565	46.5 to 58	336 to 420
22	32	688	70.3	508	610 to 765	62.5 to 78	452 to 564
24	36	883	90	651	785 to 980	80 to 100	579 to 753
27	41	1295	133	957	1150 to 1440	118 to 147	853 to 1060
30	46	1715	175	1265	1520 to 1910	155 to 195	1120 to 1410
33	50	2205	225	1630	1960 to 2450	200 to 250	1450 to 1810
36	55	2745	280	2025	2450 to 3040	250 to 310	1810 to 2240
39	60	3260	333	2405	2890 to 3630	295 to 370	2130 to 2680

Tighten the hoses to the torque shown in the table.

Taper seal

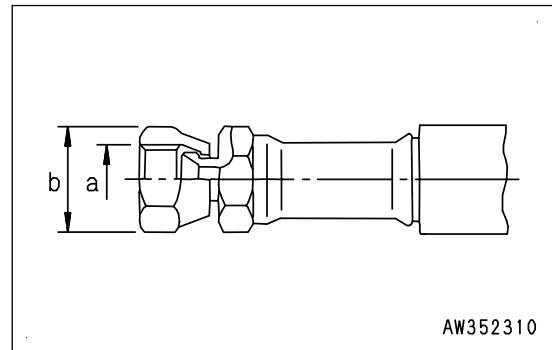

Outside diameter of hose "a" (mm)	Width across flats "b" (mm)	Tightening torque					
		Target value			Allowable range		
		Nm	kgm	lbft	Nm	kgm	lbft
14	19	44	4.5	32.5	34 to 63	3.5 to 6.5	25.3 to 47.0
18	24	78	8.0	57.9	59 to 98	6.0 to 10.0	43.4 to 72.3
22	27	103	10.5	75.9	84 to 132	8.5 to 13.5	61.5 to 97.6
24	32	157	16.0	116	128 to 186	13.0 to 19.0	94 to 137
30	36	216	22.0	159	177 to 245	18.0 to 25.0	130 to 181
33	41	216	22.0	159	177 to 245	18.0 to 25.0	130 to 181
36	46	245	25.0	181	197 to 294	20.0 to 30.0	145 to 217
42	55	294	30.0	217	246 to 343	25.0 to 35.0	181 to 253

Face seal

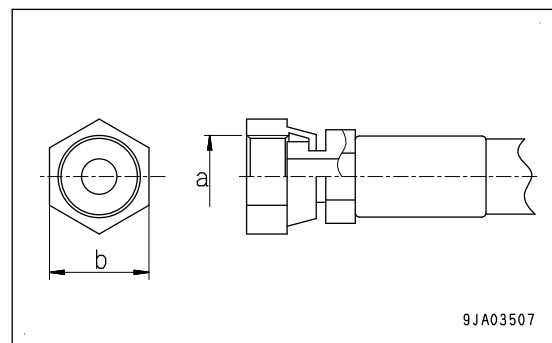

Nominal - No. of threads "a"	Width across flats "b" (mm)	Tightening torque					
		Target value			Allowable range		
		Nm	kgm	lbft	Nm	kgm	lbft
$9/16$ -18UN	19	44	4.5	32.5	34 to 54	3.5 to 5.5	25.3 to 39.8
$11/16$ -16UN	22	74	7.5	54.2	54 to 93	5.5 to 9.5	39.8 to 68.7
$13/16$ -16UN	27	103	10.5	75.9	84 to 132	8.5 to 13.5	61.5 to 97.6
1-14UNS	32	157	16.0	116	128 to 186	13.0 to 19.0	94.0 to 137
$13/16$ -12UN	36	216	22.0	159	177 to 245	18.0 to 25.0	130 to 181

MAINTENANCE SCHEDULE

- If the machine is equipped with a hydraulic breaker, the maintenance interval for some parts are different. Check the maintenance interval and perform maintenance by referring to “MAINTENANCE INTERVAL FOR HYDRAULIC BREAKER”.
- Ask your Komatsu distributor for changing the maintenance interval of the machine monitor.

MAINTENANCE SCHEDULE TABLE

INITIAL 10 HOURS MAINTENANCE (ONLY FOR THE FIRST 100 HOURS)	4-15
WHEN REQUIRED	4-16
METHOD FOR CHECKING, CLEANING AND REPLACING AIR CLEANER	4-16
METHOD FOR CLEANING INSIDE OF COOLING SYSTEM	4-27
METHOD FOR CHECKING BATTERY ELECTROLYTE LEVEL	4-31
METHOD FOR CLEANING FUEL PREFILTER ELEMENT	4-34
METHOD FOR CHECKING LOOSENESS AND TIGHTENING STEEL TRACK SHOE BOLTS	4-37
METHOD FOR CHECKING LOOSENESS AND TIGHTENING ROAD LINER SHOE BOLTS	4-38
METHOD FOR CHECKING AND ADJUSTING STEEL SHOES AND ROADLINERS TRACK TENSION	4-39
METHOD FOR CHECKING ROAD LINER	4-41
METHOD FOR REPLACING ROAD LINER	4-41
METHOD FOR CHECKING RUBBER SHOES	4-42
METHOD FOR CHECKING AND ADJUSTING RUBBER SHOES TRACK TENSION	4-43
METHOD FOR REPLACING RUBBER SHOES	4-45
METHOD FOR CHANGING SHOES	4-47
METHOD FOR REPLACING BUCKET TEETH	4-48
METHOD FOR CHECKING WINDOW WASHER FLUID LEVEL, ADDING FLUID	4-51
METHOD FOR CHECKING AND MAINTENANCE AIR CONDITIONER	4-52
METHOD FOR LUBRICATING BOOM SWING CYLINDER FOOT PIN	4-54
METHOD FOR WASHING WASHABLE FLOOR	4-56
METHOD FOR CHECKING GAS SPRING	4-57
METHOD FOR BLEEDING AIR FROM HYDRAULIC CIRCUIT	4-58
METHOD FOR CHECKING SWING PINION GREASE LEVEL, ADD GREASE	4-62
CHECKS BEFORE STARTING	4-63
EVERY 100 HOURS MAINTENANCE	4-64
METHOD FOR LUBRICATING	4-64
METHOD FOR LUBRICATING SWING SYSTEM	4-64
METHOD FOR LUBRICATING WORK EQUIPMENT	4-65
EVERY 250 HOURS MAINTENANCE	4-67
METHOD FOR CHECKING AND ADJUSTING AIR CONDITIONER COMPRESSOR BELT TENSION	4-67
METHOD FOR CLEANING AIR CONDITIONER RECIRC AIR FILTER	4-68
EVERY 500 HOURS MAINTENANCE	4-69
METHOD FOR CHANGING OIL IN ENGINE OIL PAN, REPLACING ENGINE OIL FILTER CARTRIDGE	4-69
METHOD FOR REPLACING FUEL PREFILTER ELEMENT	4-71
METHOD FOR REPLACING FUEL MAIN FILTER CARTRIDGE	4-74
METHOD FOR CHECKING AND CLEANING RADIATOR FINS, OIL COOLER FINS, FUEL COOLER FINS, AND AIR CONDITIONER CONDENSER FINS	4-77
METHOD FOR CLEANING AIR CONDITIONER FRESH AIR FILTER	4-79
METHOD FOR REPLACING HYDRAULIC TANK BREATHER ELEMENT	4-80
METHOD FOR CHECKING OIL LEVEL IN FINAL DRIVE CASE, ADDING OIL	4-82
METHOD FOR CHECKING FAN BELT TENSION AND REPLACING FAN BELT	4-83
EVERY 1000 HOURS MAINTENANCE	4-85
METHOD FOR REPLACING HYDRAULIC OIL FILTER ELEMENT	4-85
METHOD FOR CHANGING OIL IN FINAL DRIVE CASE	4-87
METHOD FOR CHECKING AND ADJUSTING ENGINE VALVE CLEARANCE	4-87
EVERY 1500 HOURS MAINTENANCE	4-88
METHOD FOR CHECKING CRANKCASE BREATHER	4-88
EVERY 2000 HOURS MAINTENANCE	4-89

METHOD FOR CHANGING OIL IN HYDRAULIC TANK, CLEANING HYDRAULIC TANK STRAINER... 4-89
 METHOD FOR CHECKING AND RELEASING NITROGEN GAS CHARGE PRESSURE IN ACCUMULATOR (FOR CONTROL CIRCUIT) 4-93
 METHOD FOR CHECKING ALTERNATOR AND STARTING MOTOR 4-97
 EVERY 3000 HOURS MAINTENANCE 4-98
 METHOD FOR CHECKING AND CLEANING FUEL INJECTION SYSTEM..... 4-98
 EVERY 4000 HOURS MAINTENANCE 4-99
 REPLACE DEFINED LIFE PARTS 4-99
 METHOD FOR REPLACING ACCUMULATOR (FOR CONTROL CIRCUIT) 4-100
 EVERY 6000 HOURS MAINTENANCE 4-101
 METHOD FOR CLEANING KDPF 4-101

MAINTENANCE INTERVAL FOR HYDRAULIC BREAKER

For machine equipped with a hydraulic breaker, the hydraulic oil deteriorates faster than for normal bucket digging operations, so set the maintenance intervals as follows.

Replace hydraulic filter element

On a new machine, replace the element after the first 100 to 150 hours, then perform further replacement of the element according to the table.

Change of oil in hydraulic tank

Change the oil according to the table.

X: Breaker operating ratio (%)

Y: Replacement interval (H)

(A):Element of hydraulic tank

(B):Hydraulic oil

REMARK

Breaker operating ratio 100 % means that only the breaker is used.

Breaker operating ratio 0 % means that the breaker is not used.

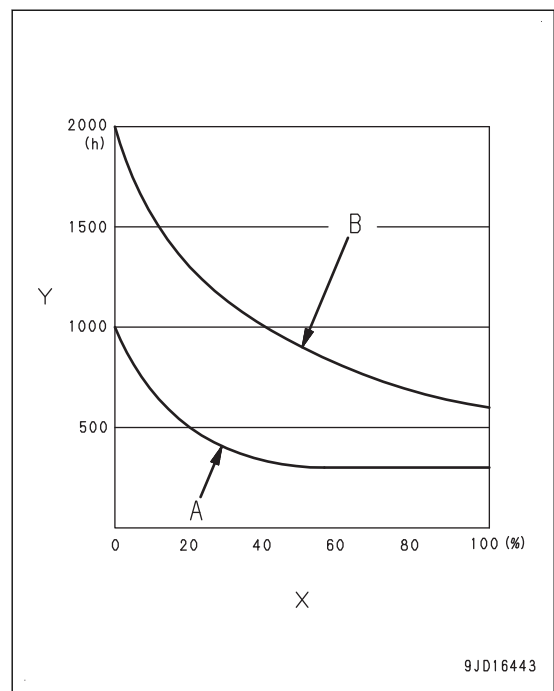

MAINTENANCE PROCEDURE

INITIAL 10 HOURS MAINTENANCE (ONLY FOR THE FIRST 100 HOURS)

Until first 100 hours operation, perform the following maintenance every 10 hours.

- Lubrication of swing equipment
- Lubrication of work equipment

For details of the method of replacement or maintenance, see "EVERY 100 HOURS MAINTENANCE".

WHEN REQUIRED

METHOD FOR CHECKING, CLEANING AND REPLACING AIR CLEANER

⚠ WARNING

When using compressed air, there is a danger that dirt may scatter and cause personal injury. Always wear protective eyeglasses, dust mask, or other protective equipment.

NOTICE

- If any dirt enters the engine, it can damage the engine. Be sure to stop the engine before checking, cleaning, or servicing the air cleaner. Do not check, clean, or service the air cleaner in strong winds or in a dusty place.
When replacing the inner element, take extreme care.
- Replace the outer element if it is cleaned 5 times repeatedly or used throughout a year. Replace the inner element as well at the same time.

METHOD FOR CHECKING AIR CLEANER

1. Pull engine rear cover (1) toward you to open it.
Open engine rear cover (1) fully and it is secured by rod (2).

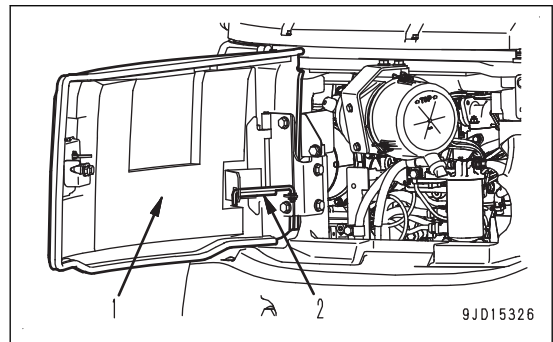

NOTICE

Do not clean the outer element before the red piston is projected into the transparent part of dust indicator (3). If the outer element is cleaned frequently before the red piston protrudes, the air cleaner cannot display its normal performance and the cleaning effect decreases.

2. Check if the red piston is projected into the transparent part of dust indicator (3).
If the red piston is projected, clean the air cleaner outer element.

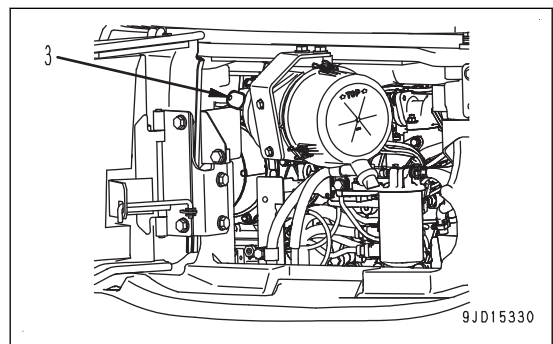

METHOD FOR CLEANING AIR CLEANER OUTER ELEMENT

NOTICE

- Do not use a screwdriver or other tool.
- When cleaning the element, do not hit it or hit anything with the element.
- Before and after cleaning the element, do not leave or keep it under direct sunlight.

METHOD FOR CLEANING AIR CLEANER OUTER ELEMENT ON MACHINE EQUIPPED WITH SINGLE ELEMENT

1. Release the hooks (4) and remove the cover (5).

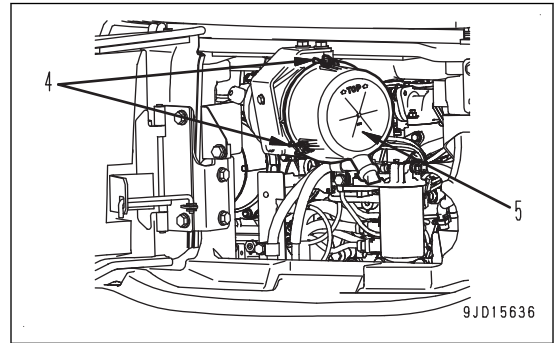

2. Hold the outer element (6), rock it lightly up and down and to the right and left, and pull out the outer element (6) while turning it to the right or left.

3. After removing the outer element (6), cover the air connector side at the bottom of the air cleaner body (7) with a clean cloth or tape to prevent dirt or dust from entering.

4. Clean the dust sticking inside the air cleaner body (7) and on the cover (5) by using a clean cloth or brush.

5. If any dust is attached to the vacuator valve (8) installed to the cover (5), remove it.

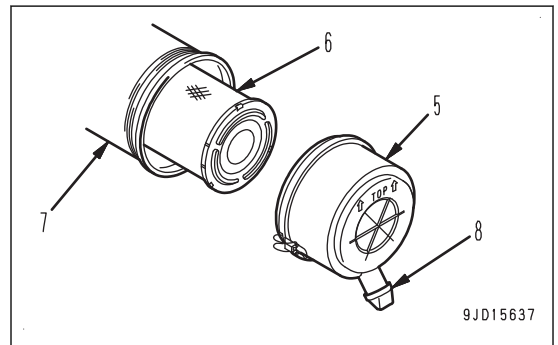

6. When the outer element (6) has been cleaned 5 times or used for 1 year, replace it with a new outer element.

If the outer element (6) does not need to be replaced, proceed the cleaning.

7. Blow dry compressed air (0.2 MPa or less {2.1 kg/cm² or less, 30.0 PSI or less}) from the inside of the outer element (6) along the pleats.

8. Blow along the pleats from the outside, then blow again from the inside.

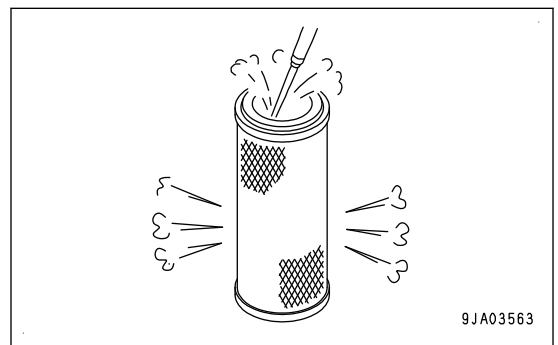

9. After the cleaning, illuminate the inside of the element with an electric bulb to check.

If any holes or thin places are found, replace the outer element with a new one.

10. Remove the cover of cloth or tape attached to the air connector side at the bottom of air cleaner body (7).

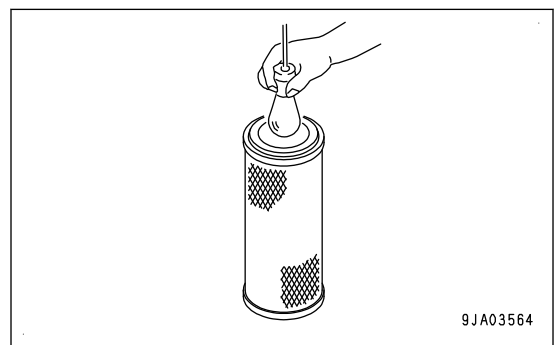

NOTICE

- Do not use the outer element with damaged pleats or a damaged gasket or seal.
- If the outer element and O-ring are cleaned and used again after they are used for more than 1 year, it will cause problems. Do not use them again.

11. Check the seal of the cleaned or new outer element (6) for adhesion of dusts and oil.
If there is any adhesion, wipe it off.

NOTICE

- Be sure to install the air cleaner element facing in the correct direction. Install so that the bottom of the air cleaner element (a) (face where no hole is drilled) comes to cover (5) end.
If it is installed in wrong direction, it may cause breakage of the air cleaner element or serious damage to the engine.
- When inserting the element into the body, if the rubber at the tip is swollen or the outer element is not pushed in straight, and cover (5) is installed by force with hook (4), there is a danger that hook (4) and air cleaner body will be damaged, so be careful when installing.

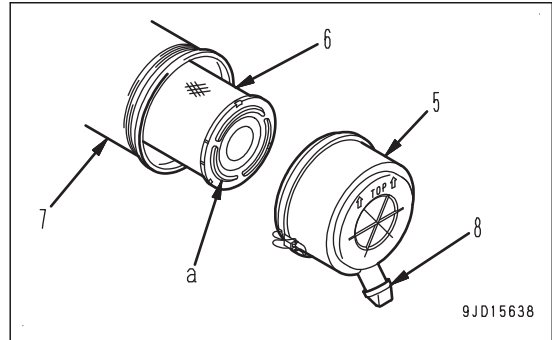

12. Push the outer element (6) straight into the air cleaner body (7) with your hand.
Hold the outer element (6), and rock it lightly up and down and to the right and left while pushing it in, the element can be inserted easily.

13. Install the cover (5).

Install the cover (5) as follows.

1) Align the mark on cover (5) with the mark on air cleaner body (7).

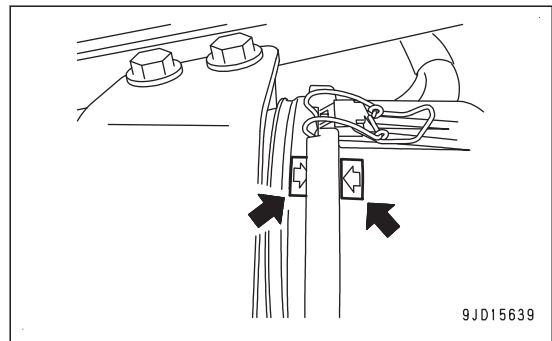

2) Lock the tip of hook (4) on the protrusion of air cleaner body (7).

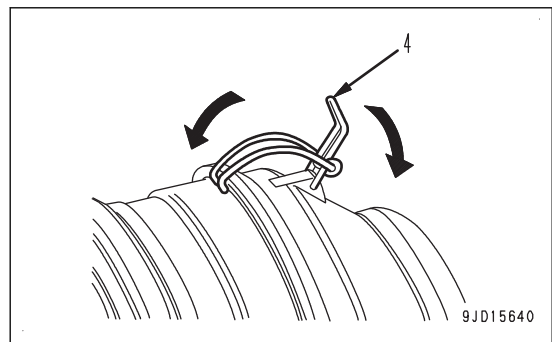

- 3) Check that TOP mark arrow (A) on cover (5) is pointing upward.
- 4) When the cover (5) is installed, check that the clearance between air cleaner body (7) and cover (5) is not too large.
If the clearance is too large, remove the cover (5), and then install it again.

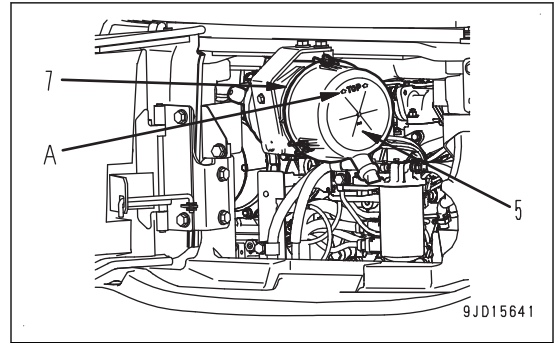

14. Press the button of dust indicator and return the red piston to the original position.

NOTICE

Replace the outer element when the dust indicator indicates red soon after cleaning the outer element, even though it has not been cleaned 5 times yet.

15. Close the engine rear cover.

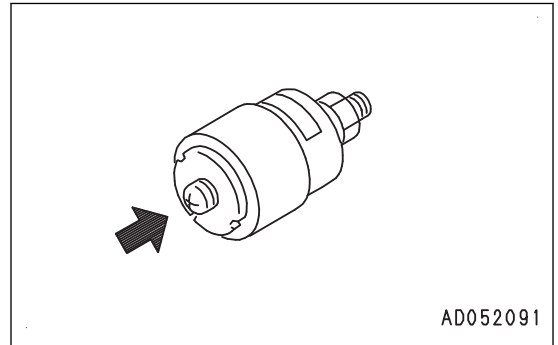

METHOD FOR CLEANING AIR CLEANER OUTER ELEMENT ON MACHINE EQUIPPED WITH DOUBLE ELEMENT

NOTICE

Never remove the inner element.

If it is removed, dirt will enter and can cause an engine trouble.

1. Release the hooks (4) and remove the cover (5).

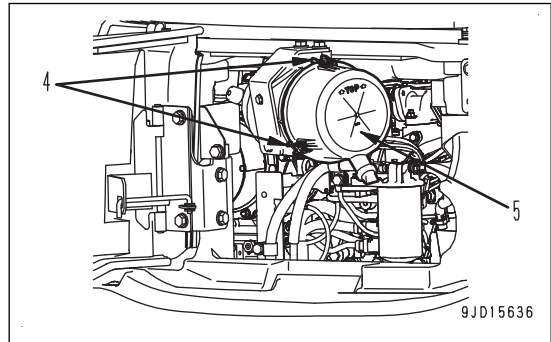

2. Hold the outer element (6), rock it lightly up and down and to the right and left, and pull out the outer element (6) while turning it to the right or left.
3. When the outer element (6) is removed, check that the inner element (9) does not come out of position and is not at an angle.

If it is at an angle, push it straight to the bottom with your hand.

4. After removing the outer element (6), cover the inner element (9) with a clean cloth or tape to prevent dirt or dust from entering.

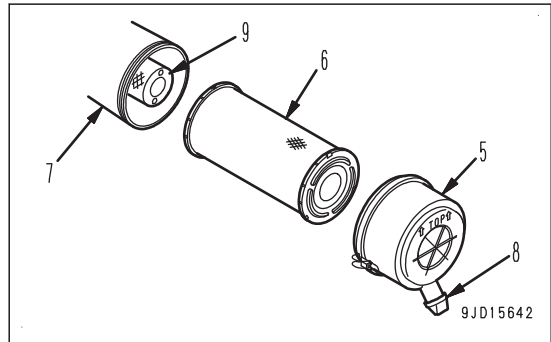

5. Clean the dust sticking inside the air cleaner body (7) and on the cover (5) by using a clean cloth or brush.
6. If any dust is attached to the vacuator valve (8) installed to the cover (5), remove it.
7. When the outer element (6) has been cleaned 5 times or used for 1 year, replace it with a new outer element.

If the outer element (6) does not need to be replaced, proceed the cleaning.

8. Blow dry compressed air (0.2 MPa or less {2.1 kg/cm² or less, 30.0 PSI or less}) from the inside of the outer element (6) along the pleats.
9. Blow along the pleats from the outside, then blow again from the inside.

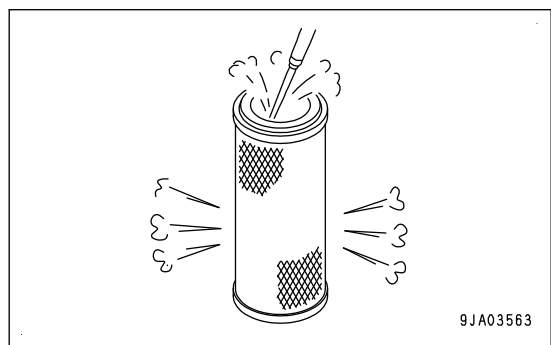

10. After the cleaning, illuminate the inside of the element with an electric bulb to check.

If any holes or thin places are found, replace the outer element with a new one.

11. Remove the cover of cloth or tape attached to inner element (9).

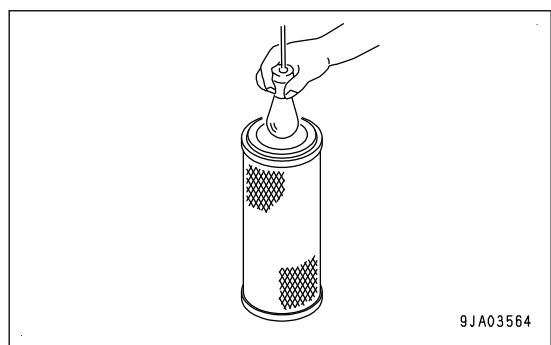

NOTICE

- Do not use the outer element with damaged pleats or a damaged gasket or seal.
 - If the outer element and O-ring are cleaned and used again after they are used for more than 1 year, it will cause problems. Do not use them again.
12. Check the seal of the cleaned or new outer element (6) for adhesion of dusts and oil.
If there is any adhesion, wipe it off.

NOTICE

- Be sure to install the air cleaner element facing in the correct direction. Install so that the bottoms (a) and (b) of the air cleaner element (face where no hole is drilled) come to the cover (5) end.
If it is installed in wrong direction, it may cause breakage of the air cleaner element or serious damage to the engine.
- When inserting the element into the body, if the rubber at the tip is swollen or the outer element is not pushed in straight, and cover (5) is installed by force with hook (4), there is a danger that hook (4) and air cleaner body will be damaged, so be careful when installing.

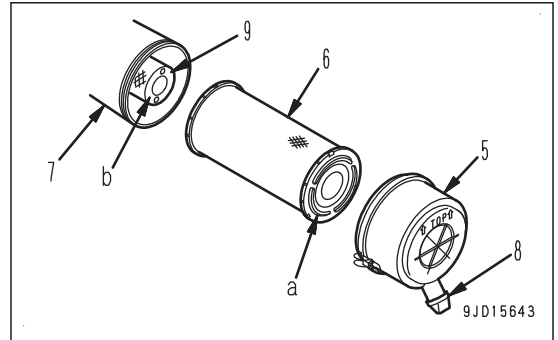

13. Push the outer element (6) straight into the air cleaner body (7) with your hand.
Hold the outer element (6), and rock it lightly up and down and to the right and left while pushing it in, the element can be inserted easily.
14. Install the cover (5).
- 1) Align the mark on cover (5) with the mark on air cleaner body (7).

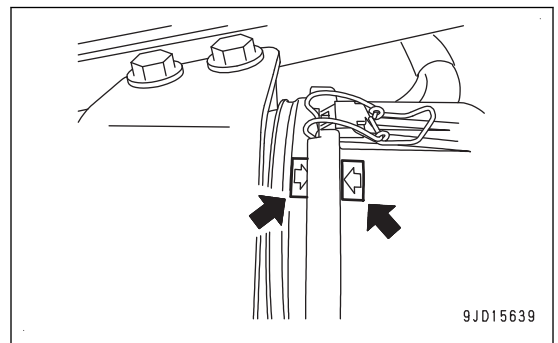

- 2) Lock the tip of hook (4) on the protrusion of air cleaner body (7).

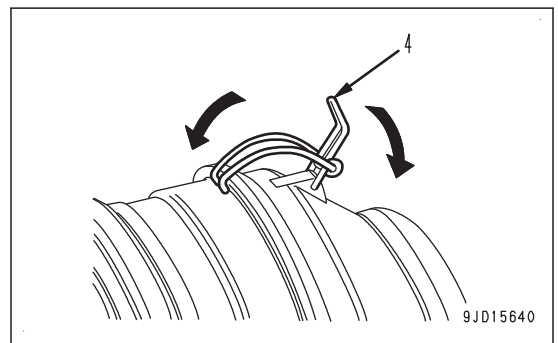

- 3) Check that TOP mark arrow (A) on cover (5) is pointing upward.
- 4) When the cover (5) is installed, check that the clearance between air cleaner body (7) and cover (5) is not too large.

If the clearance is too large, remove the cover (5), and then install it again.

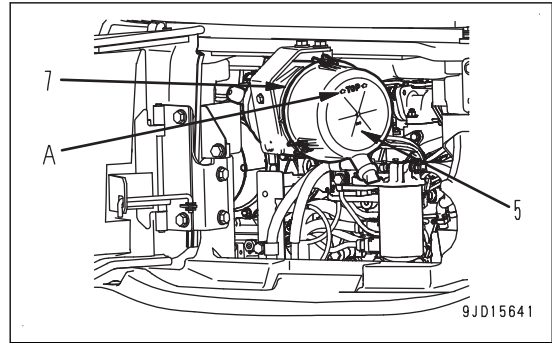

15. Press the button of dust indicator and return the red piston to the original position.

NOTICE

Replace both inner and outer elements when the dust indicator indicates red soon after cleaning the outer element even though it has not been cleaned 5 times yet.

16. Close the engine rear cover.

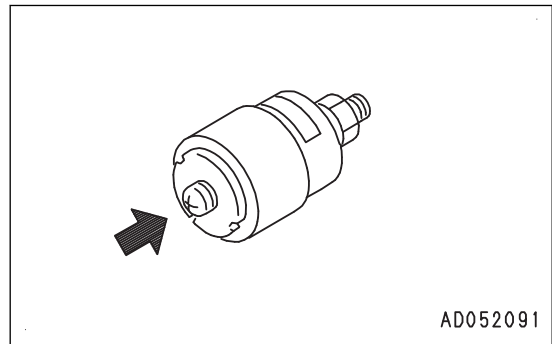

METHOD FOR REPLACING AIR CLEANER ELEMENT

METHOD FOR REPLACING AIR CLEANER ELEMENT ON MACHINE EQUIPPED WITH SINGLE ELEMENT

1. Release the hooks (4) and remove the cover (5).

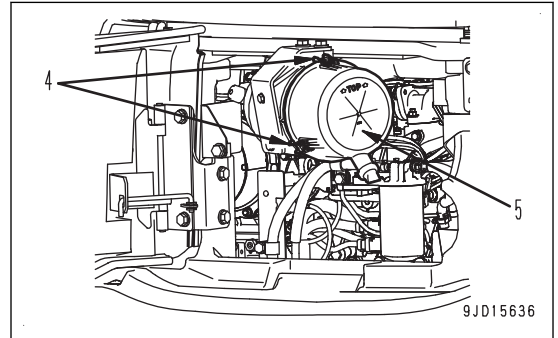

- 2. Hold the outer element (6), rock it lightly up and down and to the right and left, and pull out the outer element (6) while turning it to the right or left.
- 3. Clean the dust sticking inside the air cleaner body (7) and on the cover (5) by using a clean cloth or brush.
- 4. If any dust is attached to the vacuator valve (8) installed to the cover (5), remove it.

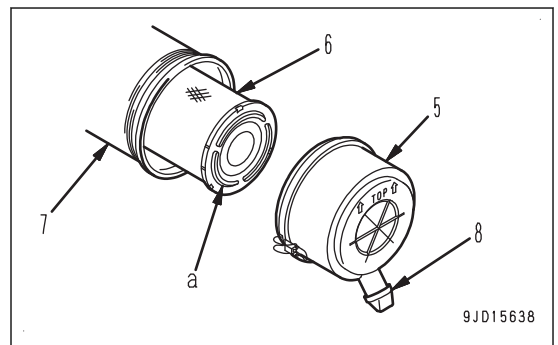

NOTICE

- The sealing portion of the improper part lacks precision, and allows the entry of dust, which leads to damage of the engine. Do not use such improper part.
 - Be sure to install the air cleaner element facing in the correct direction. Install so that the bottom of the air cleaner element (a) (face where no hole is drilled) comes to cover (5) end. If it is installed in wrong direction, it may cause breakage of the air cleaner element or serious damage to the engine.
 - When inserting the element into the body, if the rubber at the tip is swollen or the outer element is not pushed in straight, and cover (5) is installed by force with hook (4), there is a danger that hook (4) and air cleaner body will be damaged, so be careful when installing.
5. Push the new outer element in straight with your hand to the air cleaner body (7).
Hold the new outer element, and rock it lightly up and down and to the right and left while pushing it in, the element can be inserted easily.
6. Install the cover (5).
- 1) Align the mark on cover (5) with the mark on air cleaner body (7).

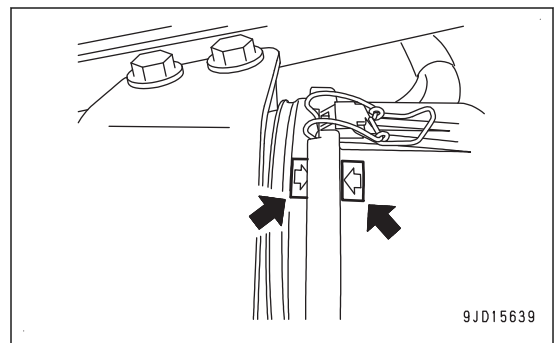

- 2) Lock the tip of hook (4) on the protrusion of air cleaner body (7).

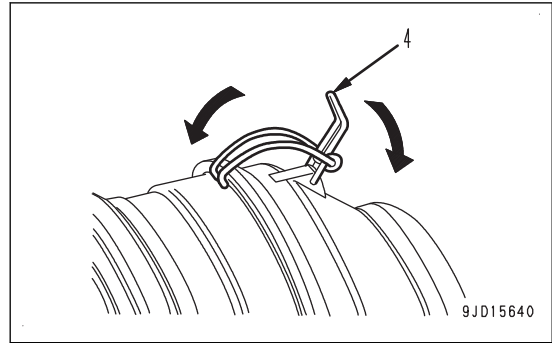

- 3) Check that TOP mark arrow (A) on cover (5) is pointing upward.
- 4) When the cover (5) is installed, check that the clearance between air cleaner body (7) and cover (5) is not too large.
If the clearance is too large, remove the cover (5), and then install it again.

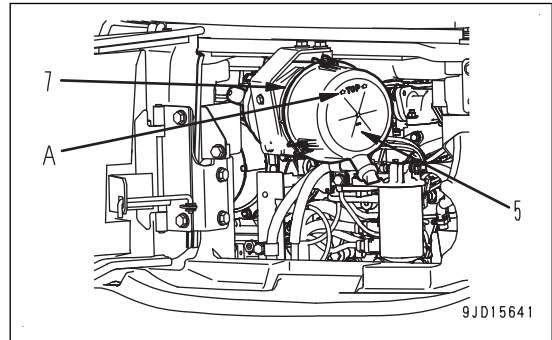

7. Press the button of dust indicator and return the red piston to the original position.
8. Close the engine rear cover.

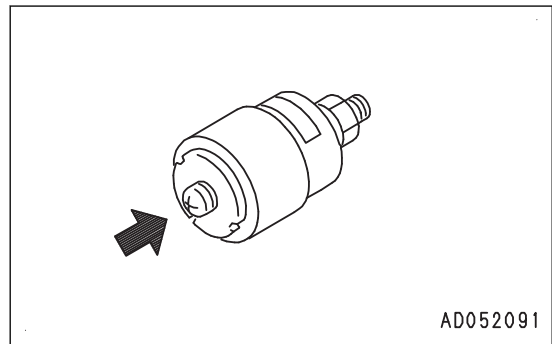

METHOD FOR REPLACING AIR CLEANER ELEMENT ON MACHINE EQUIPPED WITH DOUBLE ELEMENT

1. Release the hooks (4) and remove the cover (5).

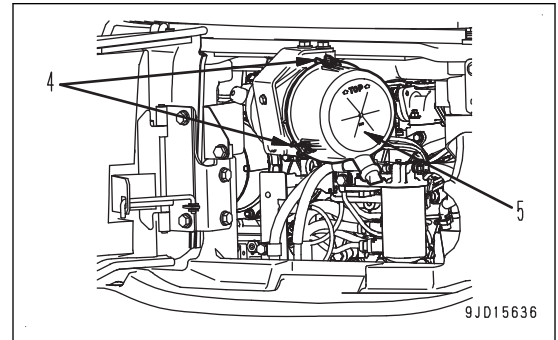

2. Hold the outer element (6), rock it lightly up and down and to the right and left, and pull it out while turning it to the right or left.

Do not remove the inner element (9) at this time.

3. When the outer element (6) is removed, check that the inner element does not come out of position and is not at an angle.

If it is at an angle, push it straight to the bottom with your hand.

4. Clean the dust sticking inside the air cleaner body (7) and on the cover (5) by using a clean cloth or brush.

5. If any dust is attached to the vacuator valve (8) installed to the cover (5), remove it.

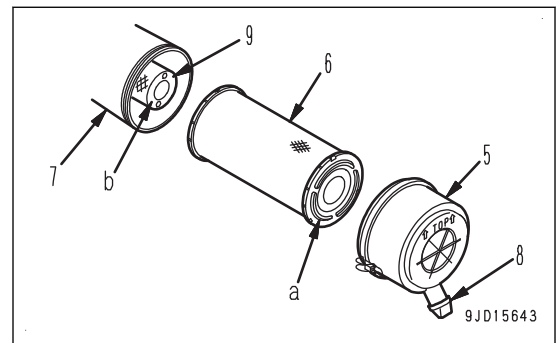

NOTICE

- **Do not clean and reuse the inner element.**
Replace the inner element with a new one at the same time when the outer element is replaced.
 - **If the outer element and cover are installed while the inner element is not installed properly, the outer element will be damaged.**
 - **The sealing portion of the improper part lacks precision, and allows the entry of dust, which leads to damage of the engine. Do not use such improper part.**
 - **Be sure to install the air cleaner element facing in the correct direction.**
Install so that the bottom of the air cleaner element (a) (face where no hole is drilled) comes to cover (5) end.
If it is installed in wrong direction, it may cause breakage of the air cleaner element or serious damage to the engine.
 - **When inserting the element into the body, if the rubber at the tip is swollen or the outer element is not pushed in straight, and cover (5) is installed by force with hook (4), there is a danger that hook (4) and air cleaner body will be damaged, so be careful when installing.**
6. Remove the inner element (9), and then quickly install the new inner element.
Install the inner element securely so that it does not move.
 7. Push the new outer element in straight with your hand to the air cleaner body (7).
Hold the outer element, and rock it lightly up and down and to the right and left while pushing it in, the element can be inserted easily.

- 8. Install the cover (5).
 - 1) Align the mark on cover (5) with the mark on air cleaner body (7).

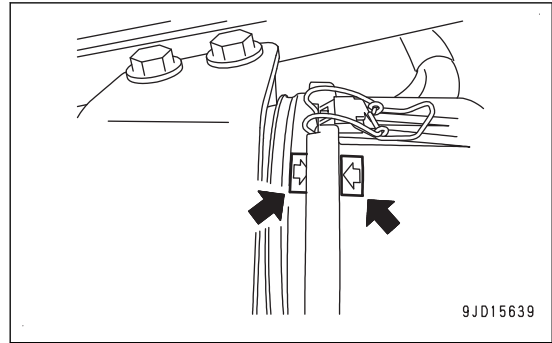

- 2) Lock the tip of hook (4) on the protrusion of air cleaner body (7).

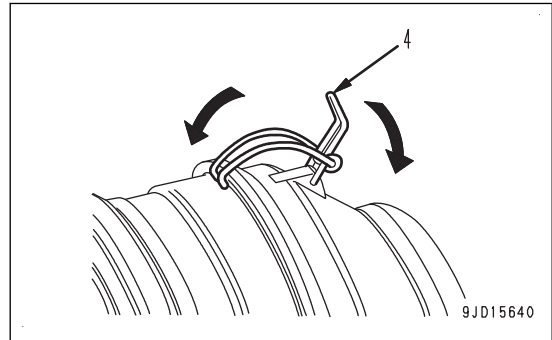

- 3) Check that TOP mark arrow (A) on cover (5) is pointing upward.
 - 4) When the cover (5) is installed, check that the clearance between air cleaner body (7) and cover (5) is not too large.
If the clearance is too large, remove the cover (5), and then install it again.

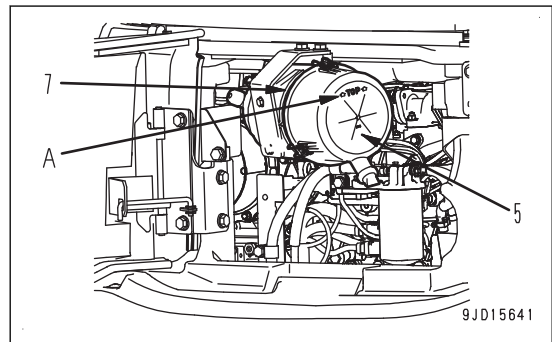

- 9. Press the button of dust indicator and return the red piston to the original position.
- 10. Close the engine rear cover.

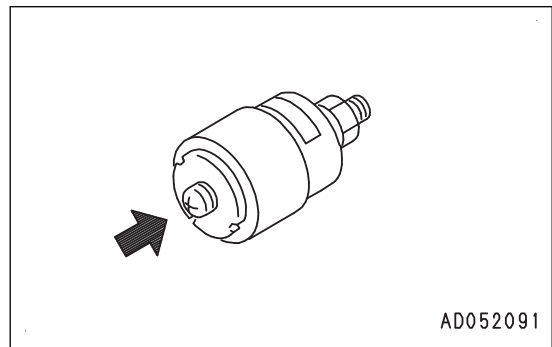

CHECK AND REPLACE VACUATOR VALVE

Check the vacuator valve.
If the vacuator is damaged or its rubber part is deformed, replace it.

METHOD FOR CLEANING INSIDE OF COOLING SYSTEM

⚠ WARNING

- **Immediately after the engine is stopped, the coolant is still hot and the pressure is accumulated in the radiator.**
If the cap is removed under this condition and the coolant is drained, it may cause burns.
Always wait for the temperature to go down, and turn the cap slowly to release the pressure.
- **Start the engine and clean the inside of the cooling system.**
When standing up or leaving the operator's seat, set the lock lever to LOCK position.
- **Since the engine is operated during washing, it is dangerous to stand at the rear of the machine when the machine moves accidentally.**
Do not enter in the rear part of the machine when the engine is running.

Place the machine on a level ground when cleaning the inside of the cooling system or changing the coolant. Clean the inside of the cooling system, or change the coolant according to the table below.

Coolant	Interval for cleaning inside of cooling system and changing coolant
Non-Amine Engine Coolant (AF-NAC)	Every 2 years or every 4000 hours whichever comes sooner

The coolant has the important function of preventing corrosion as well as preventing freezing.

Even in the areas where freezing is not an issue, the use of coolant is essential.

Komatsu machines are supplied with Non-Amine Engine Coolant (AF-NAC). Non-Amine Engine Coolant (AF-NAC) has excellent anti-corrosion, antifreeze and cooling properties and can be used continuously for 2 years or 4000 hours.

Komatsu recommends the use of Non-Amine Engine Coolant (AF-NAC). If you use another coolant, it may cause serious problems, such as corrosion of the engine and aluminum parts of the cooling system.

To maintain the anti-corrosion properties of Non-Amine Engine Coolant (AF-NAC), always keep the density of Non-Amine Engine Coolant in the range of 30 to 64 %.

Non-Amine Engine Coolant (AF-NAC) is already diluted with distilled water. When using coolant, investigate the lowest temperature in the past and decide the density for the coolant from the coolant density table below.

When deciding the density for the coolant, set it for a temperature 10 below the actual lowest temperature in the working area.

The coolant density varies according to the ambient temperature, but it must be 30 % or more at least.

Coolant density table

Min. atmospheric temperature	°C	-10 or more	-15	-20	-25	-30	-35	-40	-45	-50
	°F	14 or more	5	-4	-13	-22	-31	-40	-49	-58
Density (%)		30	36	41	46	50	54	58	61	64

⚠ WARNING

- **Coolant is toxic.**
When opening the drain valve, be careful not to get coolant on you.
If it gets in your eyes, flush your eyes with large amount of fresh water and see a doctor immediately.
- **When handling the cooling water containing coolant that has been drained during changing the coolant or repair of radiator, request a qualified company to perform the operation or contact your Komatsu distributor.**
Coolant is toxic, so never pour it into drainage ditches or drain it onto the ground surface.

- Non-Amine Engine Coolant (AF-NAC) is already diluted with distilled water, so it is not flammable.
- Check the density with a coolant tester.

Items to be prepared

- A container whose capacity is enough to receive the coolant of specified capacity
- A hose to add coolant

1. Stop the machine on a level place.
2. Stop the engine.
3. Pull the engine rear cover (1) backward to open it.
Open the engine rear cover (1) fully and it is secured by rod (2).

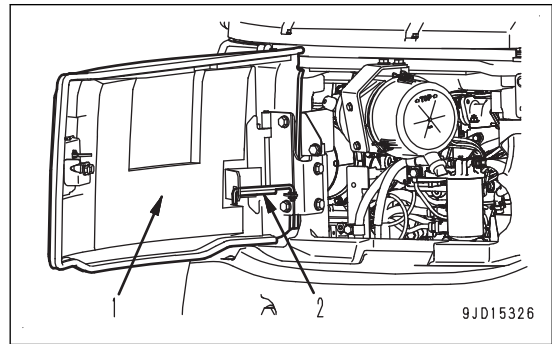

4. Pull the cooling cover (3) backward to open it.

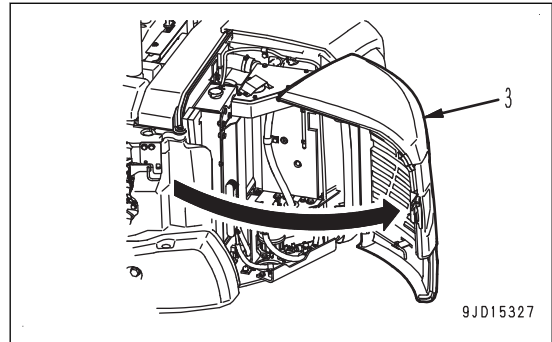

5. Turn the rod (4) to LOCK position (L), and fix the cooling cover (3) with the rod.

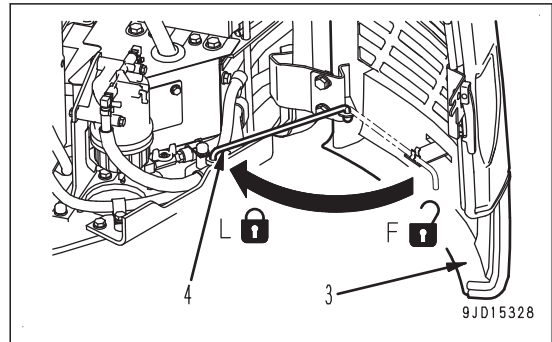

6. Check that the coolant temperature is low enough for you to touch the surface of radiator cap (5) by bare hand, and turn the radiator cap (5) slowly until it hits the stopper, and release the pressure.
7. Then, while pushing the radiator cap (5), turn it until it touches the stopper, and remove it.

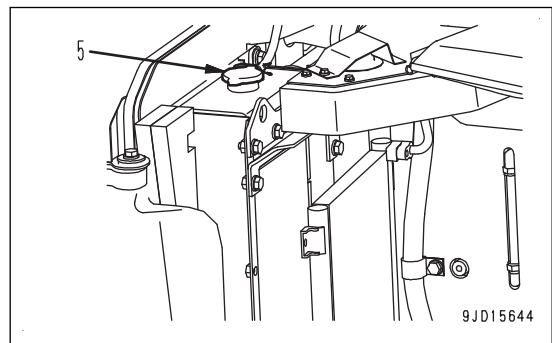

8. Place a container to catch the coolant under the drain hose installed to the drain valve (6).

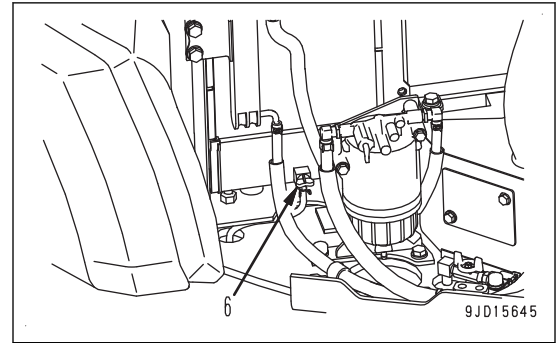

REMARK

For the machine with air conditioner, the drain valve (6) is located at the position shown in the figure.

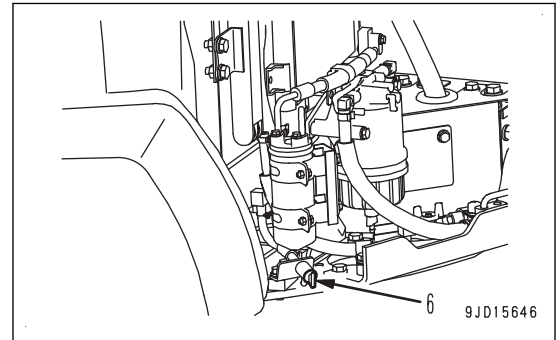

9. Open the drain valve (6) to drain the coolant.
10. After draining the coolant, close the drain valve (6).
11. Fill the radiator with tap water.
Add tap water until it fills the radiator.
12. Start the engine and run it at low idle.
Continue running the engine at low idle for 10 minutes.
13. Stop the engine.
14. Open the drain valve (6) to drain the tap water.
15. After draining the tap water, close the drain valve (6).
16. Add coolant through the water filler port up to the mouth of the port.
For the coolant density, see "Coolant density table".
17. Run the engine at low idle for 5 minutes to remove the air from the coolant, then run at high idle for a further 5 minutes.
Keep the radiator cap (5) removed during the above operations.

18. Drain the coolant in the reservoir tank (7).
19. Clean the inside of the reservoir tank (7).
20. Add coolant up to the middle between FULL and LOW.
21. Stop the engine.
22. Approximately 3 minutes later, add coolant to near the mouth of the water filler port.
23. Tighten the radiator cap (5) securely.
24. Turn the rod (4) to FREE position (F), and close the cooling cover (3).
25. Close the engine rear cover (1).

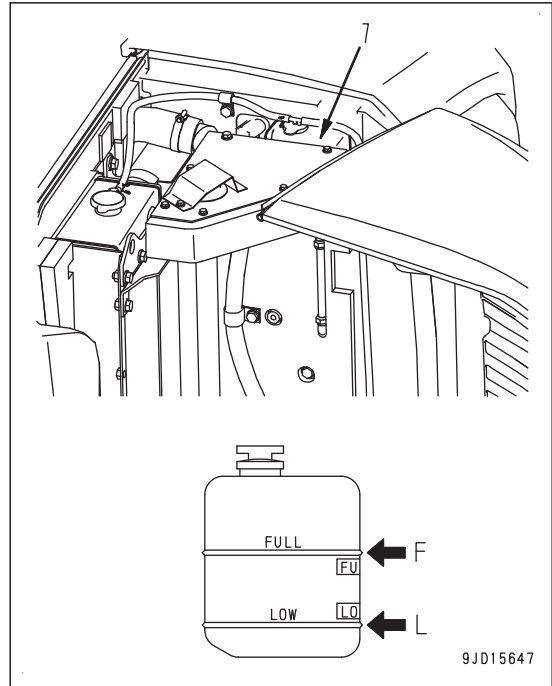

METHOD FOR CHECKING BATTERY ELECTROLYTE LEVEL** WARNING**

- Do not use the battery if the battery electrolyte level is below LOWER LEVEL line. If you do so, it will reduce the service life of the battery. In addition, it may cause an explosion.
 - Do not bring any open flame near the battery. Otherwise, it may explode since the battery generates the flammable gas.
 - Battery electrolyte is dangerous object. If it gets in your eyes or on your skin, wash it off with a large amount of water and consult a doctor.
 - Do not use a dry wipe to clean the battery. A wet wipe will prevent fire or explosion from static electricity.
-

NOTICE

- Do not add the electrolyte to the battery exceeding UPPER LEVEL line. If the electrolyte level is too high, it may leak and cause damage to the paint surface or corrode other parts.
- If there is a fear that the battery water may freeze after refilling with purified water (such as a commercial battery fluid), do the replenishment before the day's work on the next day.

Perform this procedure before operating the machine.

Inspect the battery electrolyte level according to the standard at least once a month.

METHOD FOR CHECKING ELECTROLYTE LEVEL FROM SIDE OF BATTERY

- 1. Open dirt cover (1).
Open dirt cover (1) fully and it will be secured by cover support lever (2).

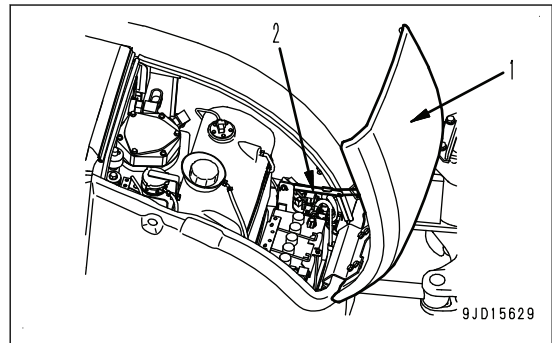

- 2. Use a wet cloth to clean the area around the electrolyte level lines and check that the electrolyte level is between UPPER LEVEL and LOWER LEVEL lines.

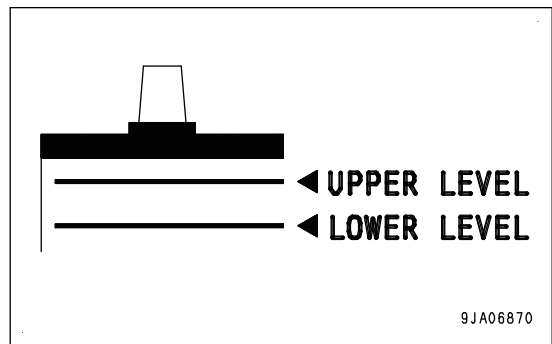

- 3. If the electrolyte level is below the middle between UPPER LEVEL and LOWER LEVEL lines, immediately remove cap (3) and add purified water (e.g. commercially available replenishment water for a battery) to UPPER LEVEL line.

REMARK

If the purified water is added to above UPPER LEVEL line of battery electrolyte, remove the fluid by using a syringe to lower the level to UPPER LEVEL line.

Neutralize the removed replenishment water for a battery with baking soda (sodium bicarbonate), then flush it away with a large amount of water or consult your Komatsu distributor or battery manufacturer.

- 4. After adding, tighten cap (3) securely.
- 5. Close dirt cover (1).

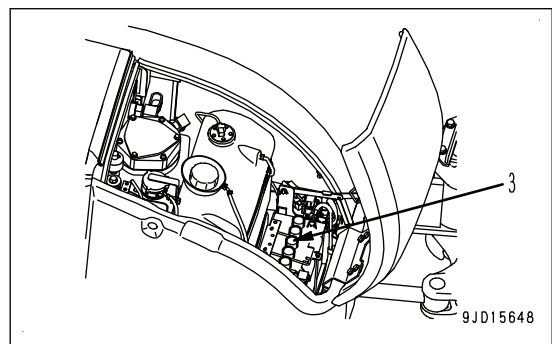

METHOD FOR CHECKING ELECTROLYTE LEVEL WHEN IT IS IMPOSSIBLE TO CHECK FROM SIDE OF BATTERY

If it is impossible to check the electrolyte level from the side of the battery, or there is no UPPER LEVEL line on the side of the battery, check as follows.

1. Open dirt cover (1).

Open dirt cover (1) fully and it will be secured by cover support lever (2).

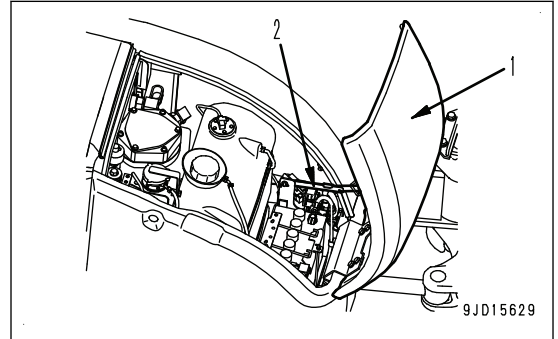

2. Remove caps (3) from the top of the battery.

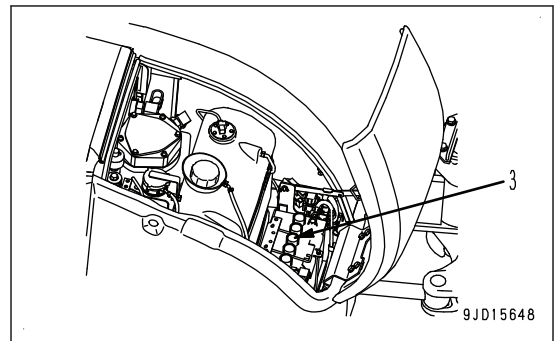

3. Look into fluid filler port (4) and check the electrolyte level.
4. If the electrolyte does not reach sleeve (5), immediately add the purified water (e.g. commercially available replenishment water for a battery) so that the level reaches the bottom of sleeve (5) (UPPER LEVEL line).

(A) Suitable level

Electrolyte level is up to bottom of sleeve (5), so surface tension causes electrolyte surface to bulge and poles appear bent.

(B) Low level

Electrolyte level is not up to bottom of sleeve (5), so poles appear straight and not bent.

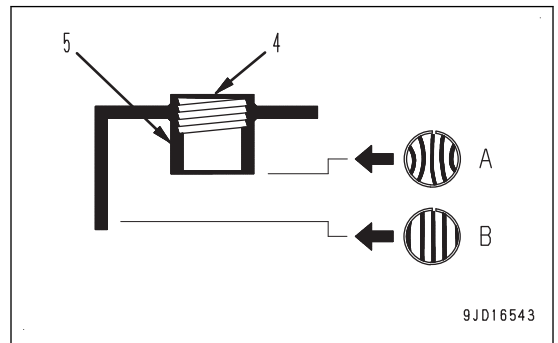

REMARK

If the purified water is added to above the lower end of the sleeve (UPPER LEVEL line), remove the fluid by using a syringe to lower the level to the lower end of the sleeve (UPPER LEVEL line).

Neutralize the removed replenishment water for a battery with baking soda (sodium bicarbonate), then flush it away with a large amount of water or consult your Komatsu distributor or battery manufacturer.

5. After adding, tighten cap (3) securely.
6. Close dirt cover (1).

METHOD FOR CHECKING ELECTROLYTE LEVEL WHEN IT IS POSSIBLE TO USE INDICATOR TO CHECK ELECTROLYTE LEVEL

If it is possible to use an indicator to check the electrolyte level, follow the instructions given.

METHOD FOR CLEANING FUEL PREFILTER ELEMENT

⚠ WARNING

Do not bring any open flame close.

Items to be prepared

Container to catch the fuel

1. Set the machine in the posture shown in the figure.

1) Start the engine.

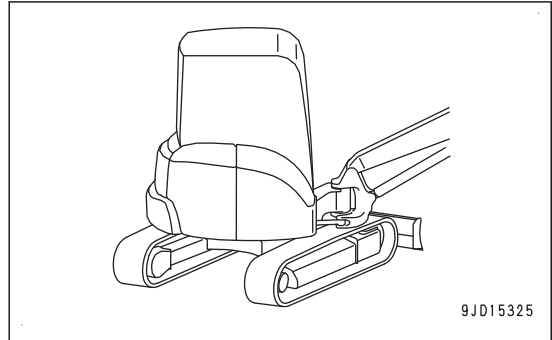

2) Set the lock lever to FREE position (F).
Be sure to operate the lock lever by the operating portion on the top.

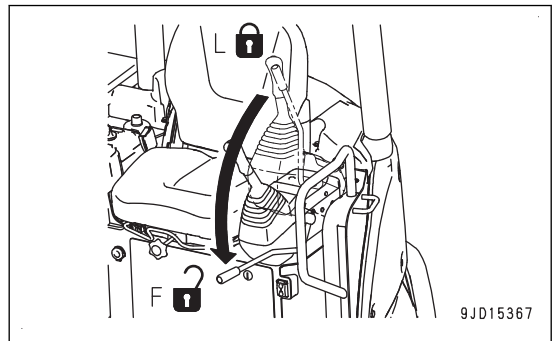

3) Operate the work equipment control lever slowly to the right and left to swing the upper structure so that the fuel prefilter comes between the tracks.

4) Operate the work equipment control levers, and lower the work equipment to the ground.

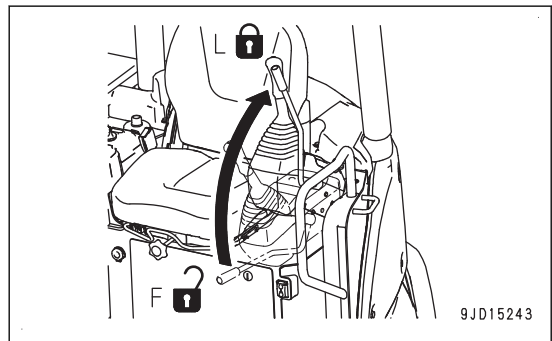

5) Set the lock lever to LOCK position (L).
Be sure to operate the lock lever by the operating portion on the top.

6) Stop the engine.

2. Pull the engine rear cover (1) backward to open it.

Open the engine rear cover (1) fully and it is secured by rod (2).

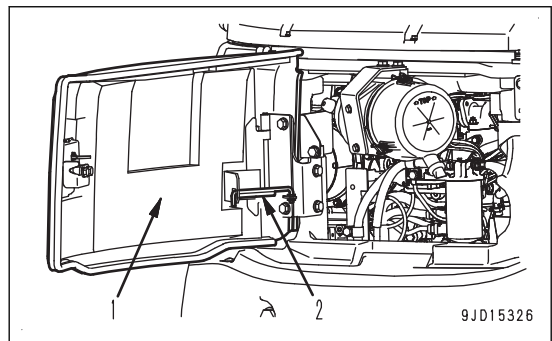

3. Pull the cooling cover (3) backward to open it.

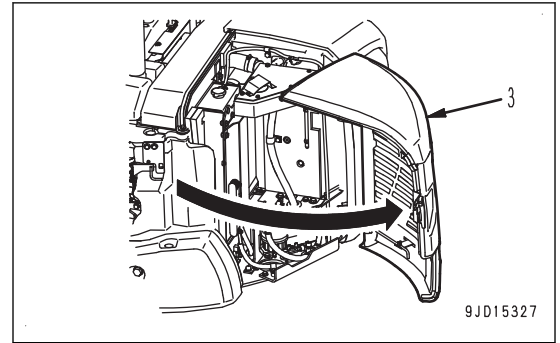

4. Turn the rod (4) to LOCK position (L), and fix the cooling cover (3) with the rod.

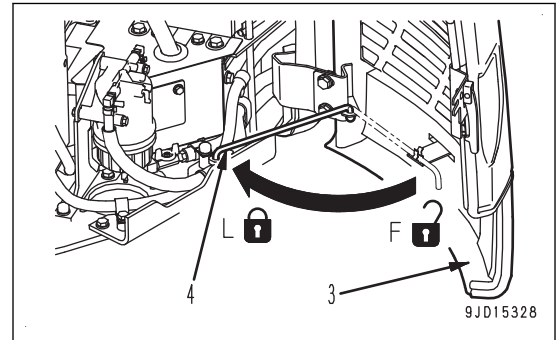

5. Loosen the bolts (5) and remove the undercover (6).
6. Place a container under the fuel prefilter to catch the fuel.

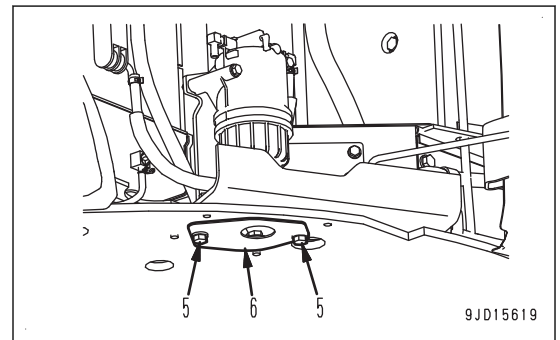

7. Turn the handle (7) to CLOSE position (S), and loosen the drain plug (8).
8. Drain the water until the red ring (9) contacts to the bottom of transparent cup (10).
9. Tighten the drain plug (8).

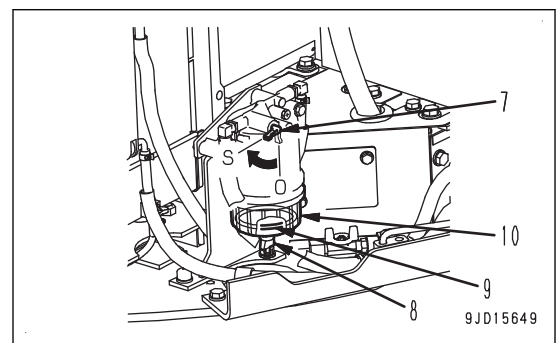

10. Turn the transparent cup (10) counterclockwise to remove it.
 Remove the transparent cup (10) without spilling the fuel.
 If the fuel spills, wipe them off with cloth thoroughly.
 Be careful not to lose the red ring (9) in transparent cup (10).

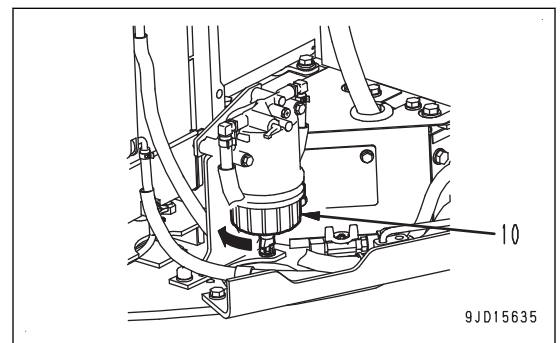

11. Remove the element (11) from top of the fuel prefilter.
12. Clean the inside of transparent cup (10) and element (11) with diesel fuel or flushing oil.
13. After cleaning, install the element (11) and O-ring (12) to transparent cup (10).
14. Insert the red ring (9) into transparent cup (10) and fill it with fuel.
15. Check the condition of O-ring (12) installed to transparent cup (10).

Replace the O-ring with a new one if needed.

16. Install the transparent cup (10) to top of fuel prefilter, and tighten it clockwise.

Tightening torque:

27 to 33 Nm {2.8 to 3.4 kgm, 19.9 to 24.4 lbf}

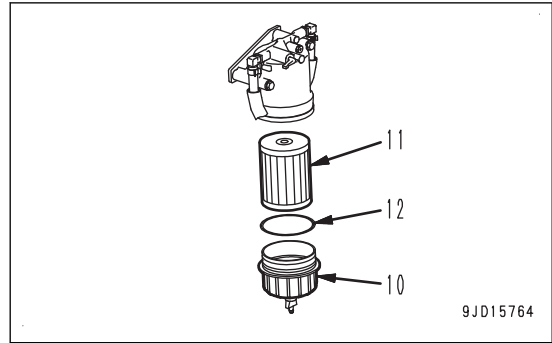

17. Turn the handle (7) to OPEN position (O).
18. Install the undercover (6) with bolts (5).
19. After the cleaning of element is completed, bleed air from the fuel circuit.

For bleeding air, see "PROCEDURES FOR BLEEDING AIR FROM FUEL CIRCUIT".

20. Turn the rod (4) to FREE position (F), and close the cooling cover (3).
21. Close the engine rear cover (1).

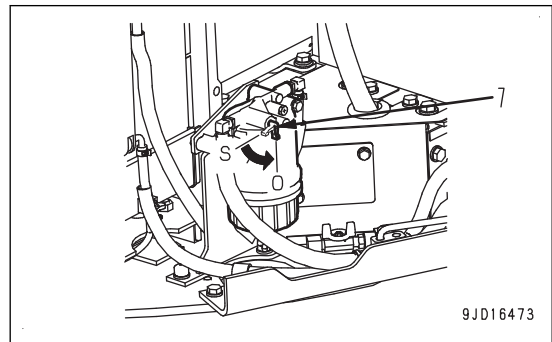
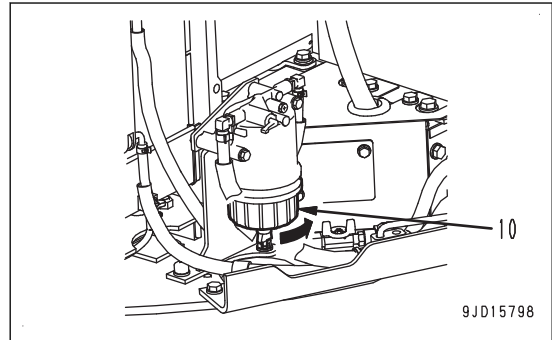

METHOD FOR CHECKING LOOSENESS AND TIGHTENING STEEL TRACK SHOE BOLTS

NOTICE

If the machine is used with steel shoe bolts loose, they will break. If any looseness of the shoe bolt is found, retighten it.

Check steel shoe bolt (1) for looseness.

If any looseness of the bolt is found, retighten it according to the following procedure.

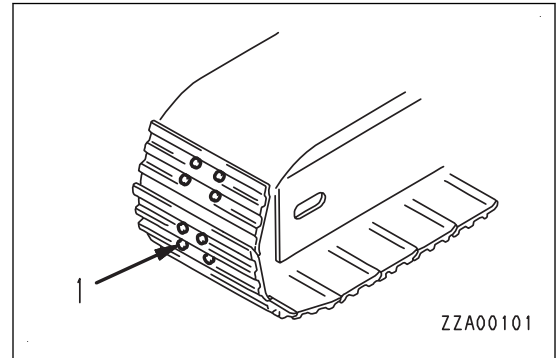

- 1) Tighten the bolt in the order shown in the figure.

Tightening torque:

118 to 157 Nm {12 to 16 kgm, 86.8 to 116 lbft}

- 2) Check that the nut and shoe are in close contact with the link contact surface.

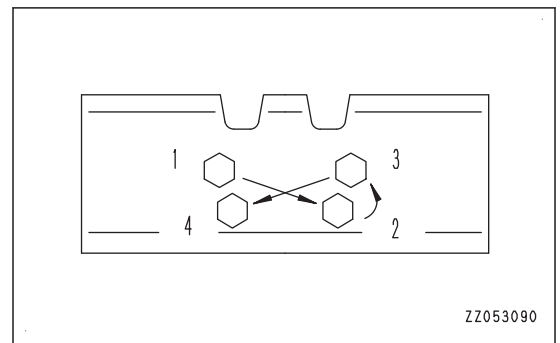

- 3) After checking, tighten a further 80 to 100 ° of tightening angle (a).

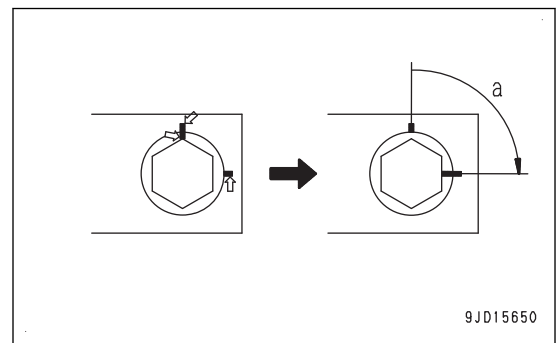

METHOD FOR CHECKING LOOSENESS AND TIGHTENING ROAD LINER SHOE BOLTS

NOTICE

If the machine is used with road liner shoe bolts loose, they will break.

Tighten any loose shoe bolts immediately.

Check for looseness of the road liner shoe bolt (1).
If any looseness of the bolt is found, retighten it according to the following procedure.

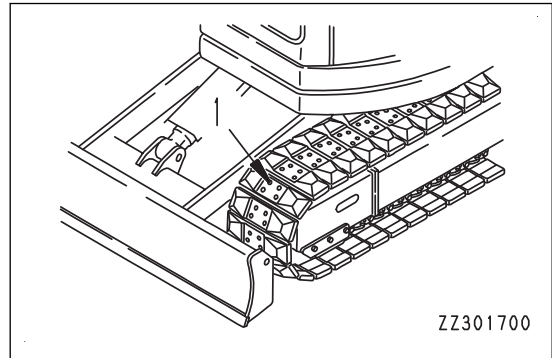

- 1) Tighten the bolt in the order shown in the figure.

Tightening torque:

118 to 156 Nm {12.0 to 15.9 kgm, 86.8 to 115 lbft}

- 2) Check that the nut and shoe are in close contact with the link contact surface.

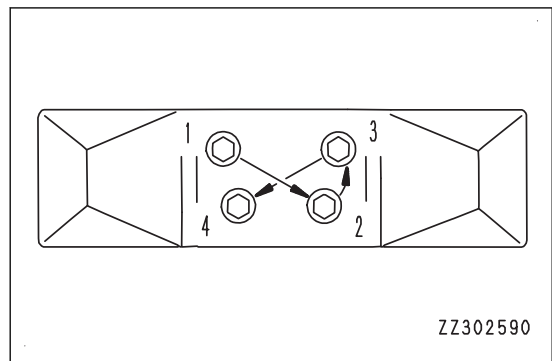

METHOD FOR CHECKING AND ADJUSTING STEEL SHOES AND ROADLINERS TRACK TENSION

The wear of the pins and bushings of the undercarriage depends on the working condition and soil condition. Check the track tension occasionally and keep it in the standard range.

Perform check and adjustment on a level and firm ground.

METHOD FOR CHECKING STEEL SHOES AND ROADLINERS TRACK TENSION

1. Run the engine at low idle, then move the machine forward for a distance equal to the track length on ground, and slowly stop the machine.
2. Place wooden block (3) which reaches from idler (1) to carrier roller (2) on the track.
3. Measure maximum deflection (a) between the under surface of the wooden block and top surface of the track.
If deflection (a) is in the standard range (10 to 30 mm {0.4 to 1.2 in}), the track tension is correct.

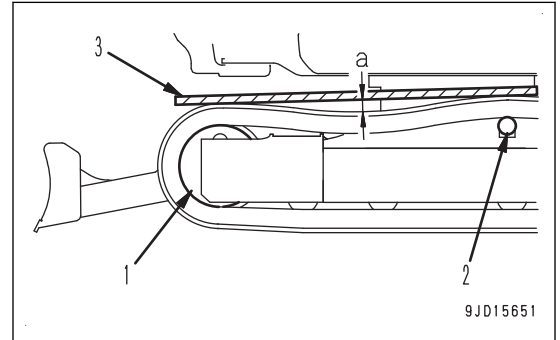

If the deflection is out of the standard range, adjust it into the standard range.

METHOD FOR INCREASING STEEL SHOES AND ROADLINERS TRACK TENSION

Items to be prepared

Grease pump

1. Pump in grease through grease fitting (4) by using a grease pump.

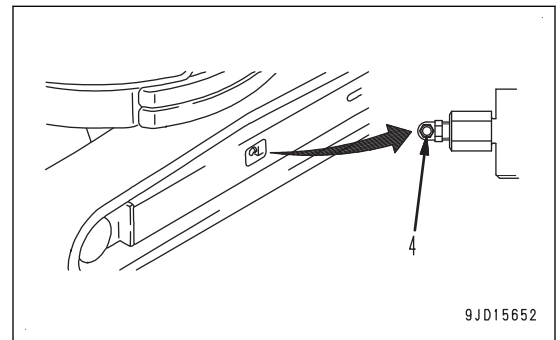

Grease can be pumped in until distance (S) from the idler support to the track frame becomes 0 mm {0 in}. If the track tension is still loose, the pins and bushings are excessively worn.

Ask your Komatsu distributor to turn the bushing 180° or replace it.

2. To check if the tension is correct, run the engine at low idle, and move the machine slowly forward by an amount equal to the length of track on ground.
3. Check the track tension again, and if the tension is not correct, adjust it again.

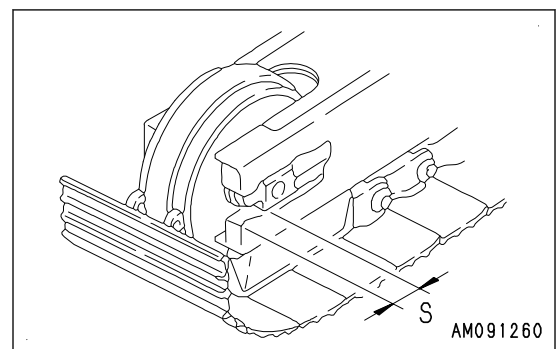

METHOD FOR DECREASING STEEL SHOES AND ROADLINERS TRACK TENSION

⚠ WARNING

- Grease is pumped into the track tension adjustment system under high pressure. If the adjustment is performed with the procedure other than following, grease drain plug (5) may fly out and cause serious injury or death.
- Do not loosen grease drain plug (5) more than 1 turn.
- Do not loosen any part other than grease drain plug (5).
- Do not put your face, hands, feet, or any other part of your body close to grease drain plug (5).

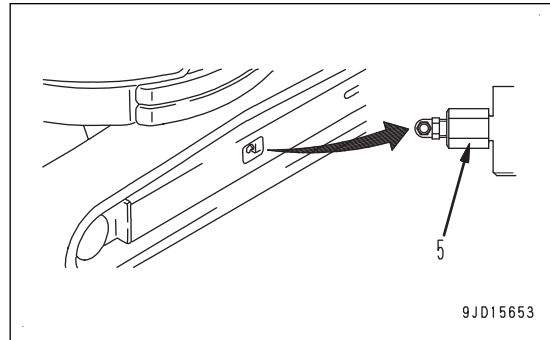

1. Loosen grease drain plug (5) gradually to release the grease.
If the grease does not come out smoothly, move the machine forward and backward a short distance.
2. Tighten grease drain plug (5) securely.
3. To check if the tension is correct, run the engine at low idle, and move the machine slowly forward by an amount equal to the length of track on ground.
4. Check the track tension again, and if the tension is not correct, adjust it again.
If the track tension cannot be decreased by the above procedure, ask your Komatsu distributor for repair.

METHOD FOR CHECKING ROAD LINER

If the road liners are in the following condition, they must be replaced. Ask your Komatsu distributor to replace it.

Lug height

- When lug height (a) is reduced to 5 mm and below {0.197 in and below}, replace it with a new one.
If lug height (a) is reduced by wear, the drawbar pull will drop

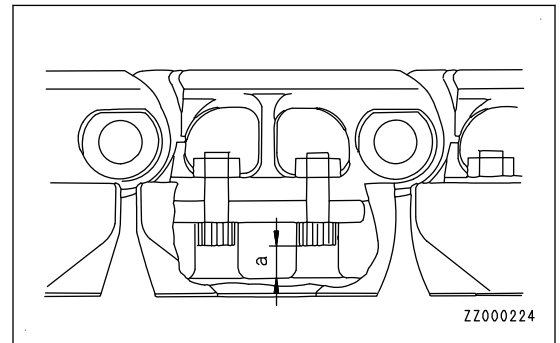

For judgment of replacement, repair, and continuation of use of the road liner, consult your Komatsu distributor.

METHOD FOR REPLACING ROAD LINER

- When all the road liners of the machine need to be replaced, ask your Komatsu distributor to replace them.
- When replacing only part of the road liner, use the special road liner removal tool. For the tools, consult your Komatsu distributor.

METHOD FOR CHECKING RUBBER SHOES

If the rubber shoe is in the following condition, it must be repaired or replaced. Ask your Komatsu distributor for repair or replacement.

Lug height

- When lug height (a) is reduced to 5 mm and below {0.197 in and below}, replace it with a new one.

If lug height (a) is reduced by wear, the drawbar pull will drop.

- (1) Track roller
- (2) Rubber shoe

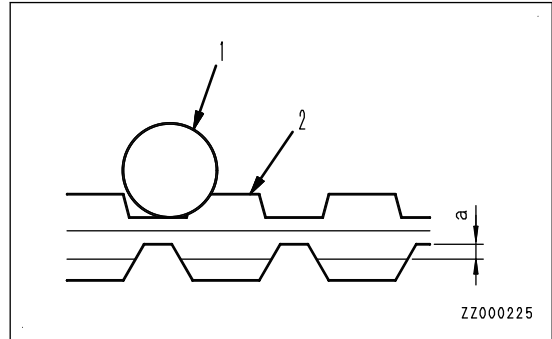

- If the lugs are worn and the steel cords in the shoes are exposed on continuous 2 or more links, replace the track with a new one.

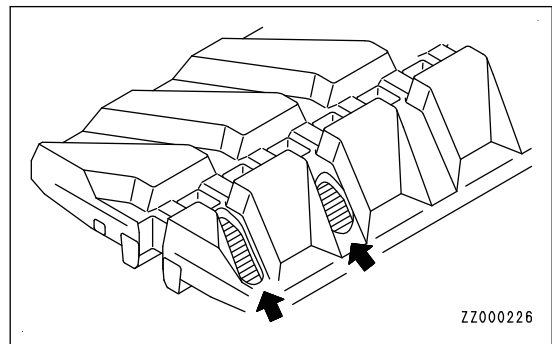

Cut of rubber shoe steel cords

If more than a half of the steel cord layer is cut on either side, replace the track with a new one.

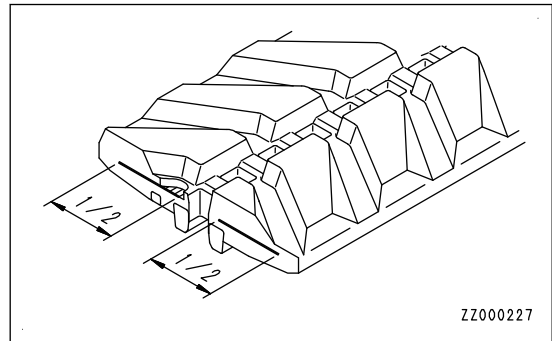

Separation of rubber shoe core metal

If the rubber shoe core metals are separated at 1 or more places, replace the track with a new one.

Rubber shoes track tension

If the rubber shoe track tension is still low after grease is supplied, replace the track with a new one or replace the seals in the cylinder.

If the rubber shoe track cannot be tensed to a degree that it does not come off, not only the track is lengthened but also the grease cylinder may have trouble.

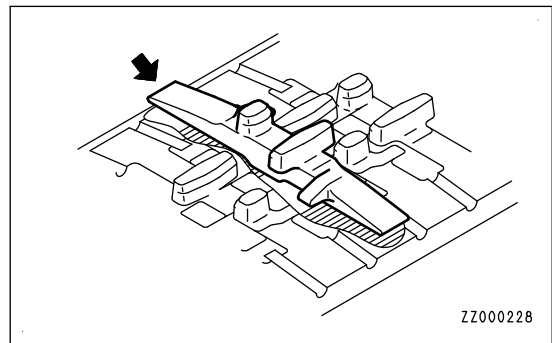

Crack in rubber shoe

When the crack between the rubber shoe lugs grows to approximately 60 mm {2.4 in} , repair it.

NOTICE

If a crack occurs and the steel cords are seen, repair it immediately, even if it is small and short.

A crack max. 30 mm {max. 1.2 in} in length and max. 10 mm {max. 0.4 in} in depth does not need to be repaired.

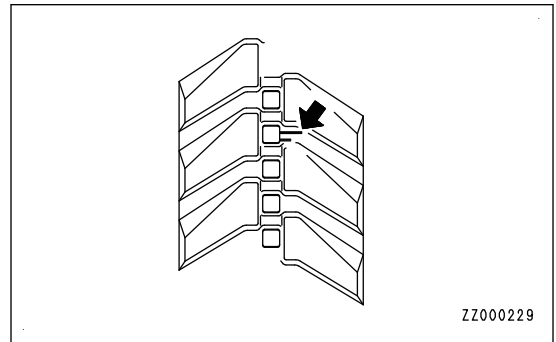

For judgment of replacement, repair, and continuation of use of the rubber shoe, consult your Komatsu distributor.

METHOD FOR CHECKING AND ADJUSTING RUBBER SHOES TRACK TENSION

- Wear of the rubber shoe depends on the working condition and type of soil. Accordingly, check the wear and track tension occasionally. For performing the inspection and adjustment of the track shoes, place the machine on a level and firm ground.
- When the machine is new or a new part is installed, the track becomes loose for 5 to 30 hours after the tension is set to the specified value while the machine travels repeatedly. If you adjust the track tension at short intervals until the initial loosening is finished, “coming off of the track caused by insufficient track tension” is prevented.
- Working with the track loosened can cause coming off of the track and rapid wear of the core metal.

METHOD FOR CHECKING RUBBER SHOES TRACK TENSION

1. Run the engine at low idle, then move the machine forward for a distance equal to the track length on ground, and slowly stop the machine.
2. Place wooden block (3) which reaches from idler (1) to carrier roller (2) on the track.
3. Measure maximum deflection (a) between the under surface of the wooden bar and top surface of the track.

If deflection (a) is in the standard range (1 to 3 mm {0.039 to 0.118 in}), the track tension is correct.

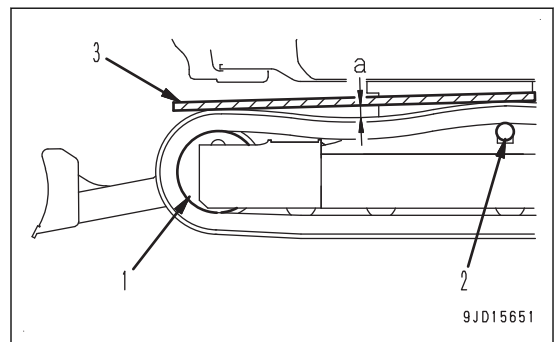

If the deflection is out of the standard range, adjust it into the standard range.

METHOD FOR INCREASING RUBBER SHOES TRACK TENSION

NOTICE

Since the standard value is small, take extreme care not to tense the rubber shoe track too much.

Items to be prepared

Grease pump

1. Pump in grease through grease fitting (4) by using a grease pump.
If the tension is still low after the grease is pumped in, ask your Komatsu distributor to replace the rubber shoe or seal in the cylinder.
2. To check if the tension is correct, run the engine at low idle, and move the machine slowly forward by an amount equal to the length of track on ground.
3. Check the rubber shoe track tension again. If it is not correct, adjust it again.

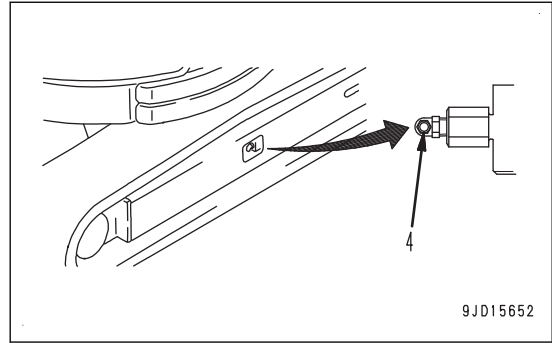

METHOD FOR DECREASING RUBBER SHOES TRACK TENSION

⚠ WARNING

- Grease is pumped into the track tension adjustment system under high pressure. If the adjustment is performed with the procedure other than following, grease drain plug (5) may fly out and cause serious injury or death.
- Do not loosen grease drain plug (5) more than 1 turn.
- Do not loosen any part other than grease drain plug (5).
- Do not put your face, hands, feet, or any other part of your body close to grease drain plug (5).

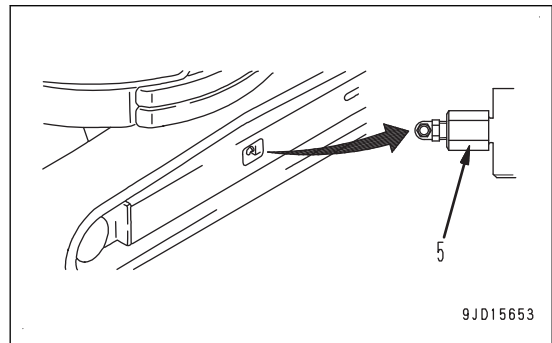

1. Loosen grease drain plug (5) gradually to release the grease.
If the grease does not come out smoothly, move the machine forward and backward a short distance.
2. Tighten grease drain plug (5).
3. To check if the tension is correct, run the engine at low idle, and move the machine slowly forward by an amount equal to the length of track on ground.
4. Check the track tension again, and if the tension is not correct, adjust it again.
If the track tension cannot be decreased by the above procedure, ask your Komatsu distributor for repair.

METHOD FOR REPLACING RUBBER SHOES

⚠ WARNING

- Perform the operation with 2 workers. The operator must operate the machine according to the signs of the worker.
- The machine must be raised to replace the rubber shoes. If the machine falls by accident at this time, it is very dangerous.
Never move any part other than the rubber shoes to be replaced during the replacement work.
Also, never put your body under the rubber shoes or track frame during the replacement work.

NOTICE

The idler cushion must be removed and adjusted when the rubber shoes are replaced with the steel shoes or road liner. Accordingly, be sure to ask your Komatsu distributor to perform the work.

Items to be prepared

- Grease pump
- Steel pipe

Set the machine to the following conditions before replacing the rubber shoes.

Set the machine in the posture shown in the figure.

1) Start the engine and run it at low idle.

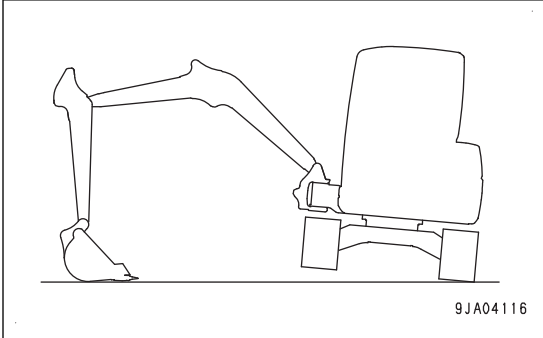

2) Set the lock lever to FREE position (F).

Be sure to operate the lock lever by the operating portion on the top.

3) Operate the work equipment control lever to swing the upper structure to make it right angle with the undercarriage.

Bring the work equipment to the side of the track.

4) Operate the work equipment control levers, and push up the machine slowly by using the boom and arm until the track is raised from the ground.

Operate the levers slowly.

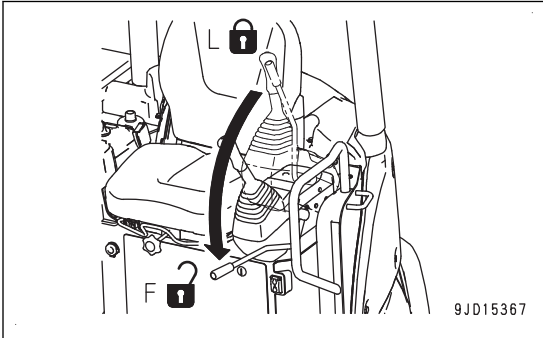

5) Set the lock lever to LOCK position (L).

Be sure to operate the lock lever by the operating portion on the top.

6) Stop the engine.

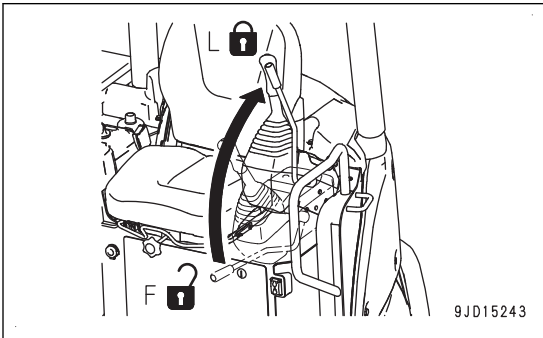

METHOD FOR REMOVING RUBBER SHOES

⚠ WARNING

- Grease is pumped into the track tension adjustment system under high pressure. If the adjustment is performed with the procedure other than following, grease drain plug (1) may fly out and cause serious injury or death. If the rubber shoe track is not loosened, ask your Komatsu distributor for repair.
- Do not loosen grease drain plug (1) more than 1 turn.
- Do not loosen any part other than grease drain plug (1).
- Do not put your face, hands, feet, or any other part of your body close to grease drain plug (1).
- Before removing the rubber shoe track, check that the internal grease is fully discharged, and then turn the sprocket.

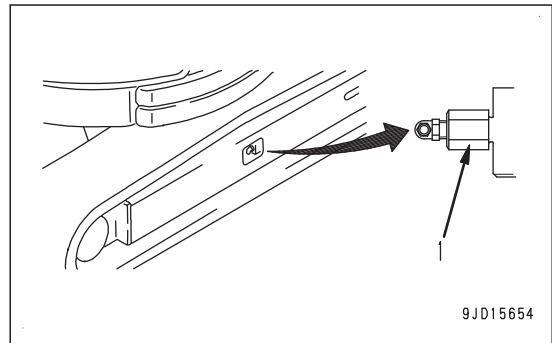

9JD15654

1. Loosen grease drain plug (1) gradually to release the grease.
2. Insert the steel pipes (2) between the rubber shoe track and track frame.
3. Turn the sprocket in reverse direction (A).
The rubber shoe track is lifted off the idler by steel pipe (2).
4. Slide the rubber shoe track sideways (B) and remove it.

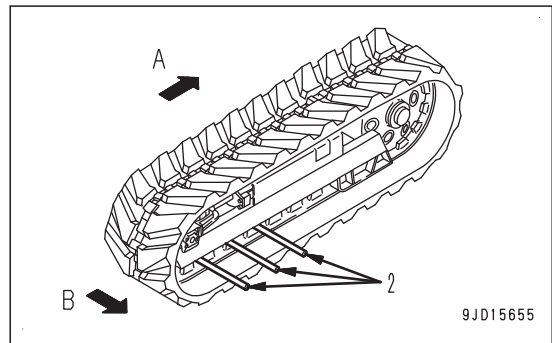

9JD15655

METHOD FOR INSTALLING RUBBER SHOES

1. Engage the rubber shoe track with the sprocket and place it over the idler.
2. Rotate the sprocket in reverse direction (A), push in the rubber shoe track, and stop the rotation.

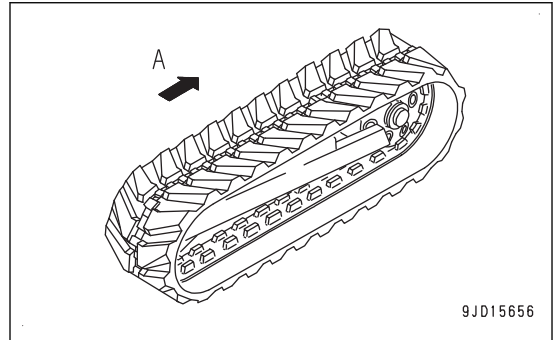

3. Insert the steel pipes (2) between the rubber shoe track and track frame.
4. Rotate the sprocket in reverse direction (A) again, engage the rubber shoe track with the idler securely, and then stop the rotation.

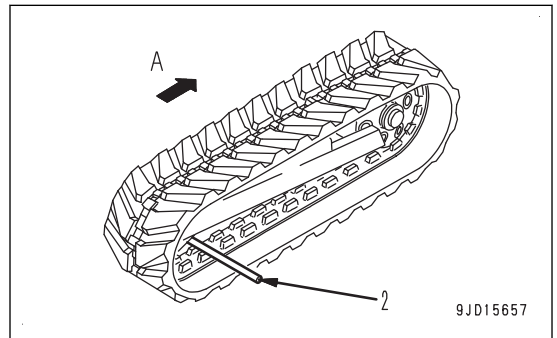

5. Check that the rubber shoe track is securely engaged with the sprocket and idler.

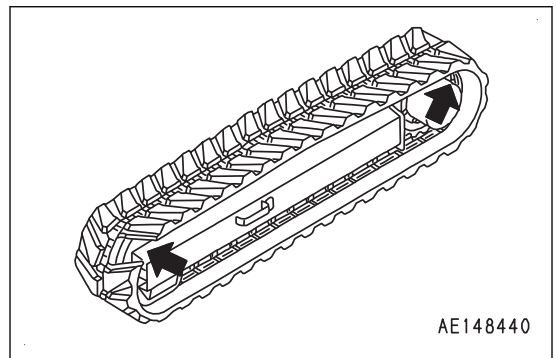

6. Adjust the rubber shoe track tension by referring to “METHOD FOR CHECKING AND ADJUSTING RUBBER SHOES TRACK TENSION”.
7. Check that the rubber shoe track is securely engaged with the sprocket and idler and its tension is correct.
8. Operate the work equipment control levers, and lower the machine slowly by using the boom and arm. Operate the levers slowly.

METHOD FOR CHANGING SHOES

⚠ WARNING

The idler cushion must be removed and adjusted when the steel shoes or road liner are replaced with the rubber shoes, or reversely. Accordingly, be sure to ask your Komatsu distributor for the replacement.

METHOD FOR REPLACING BUCKET TEETH

⚠ WARNING

- It is dangerous if the work equipment moves by mistake when the bucket tooth is being replaced. Set the work equipment in a stable condition, set the lock lever securely to LOCK position, and stop the engine.
- As the pin is driven out with strong force, it is dangerous that the pin may fly out. Check that there is no people around the machine.
- Broken pieces may fly during the replacement work, so always wear the protective equipment such as protective eyeglasses and gloves.

Replace the bucket teeth before the adapter starts to wear.

Items to be prepared

- Hammer
- Bar
- Putty knife

1. Set the machine in the posture shown in the figure so that the pin of bucket tooth (1) can be driven out.

1) Start the engine and run it at low idle.

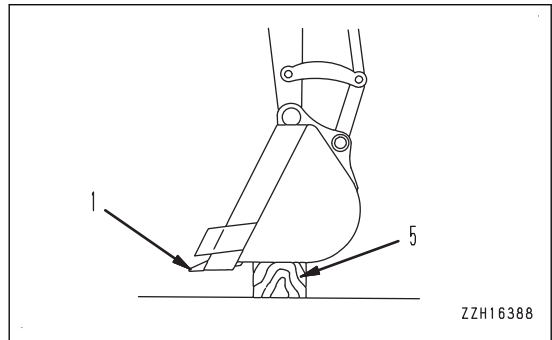

2) Set the lock lever to FREE position (F).

Be sure to operate the lock lever by the operating portion on the top.

3) Push the blade control lever forward to lower the blade to the ground.

4) Operate the work equipment control levers to make the bucket bottom level.

Set the bucket height enough to put the block (5) under the bucket bottom.

5) Put the block (5) under the bucket bottom.

6) Operate the work equipment control lever, and lower the boom gently.

Set it so that the pin of bucket tooth (1) can be driven out.

7) Check that the work equipment is in a stable condition, then set the lock lever to LOCK position (L).

Be sure to operate the lock lever by the operating portion on the top.

8) Stop the engine.

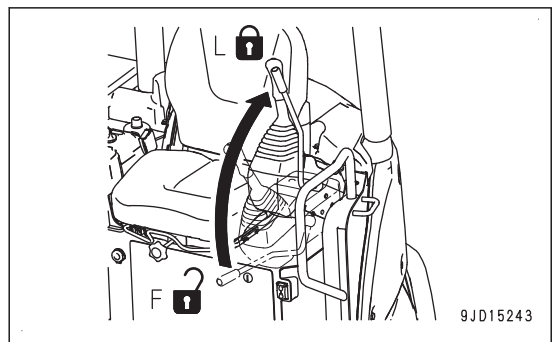
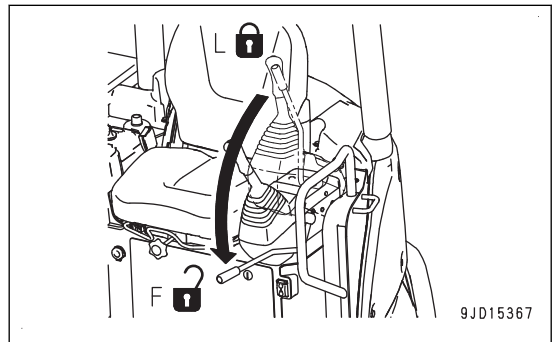

2. Use a hammer and bar to drive out the lock pin (2).
If the bar is set against rubber pin lock (3) when it is hit, the rubber pin lock (3) may break.
Set it against the back of lock pin (2).
3. After removing the lock pin (2) and rubber pin lock (3), check them.
If the lock pin (2) and rubber pin lock (3) are used in the following conditions, it will cause the bucket tooth (1) to come off during operation.
Check the shape of the parts. If they have any damage, replace them.

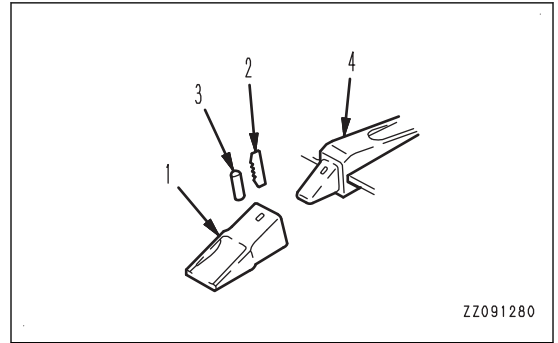

- Lock pin (2) is too short.
Dimension (B) is 1/3 or more of dimension (A) when lock pin (2) is aligned with bottom face (C).

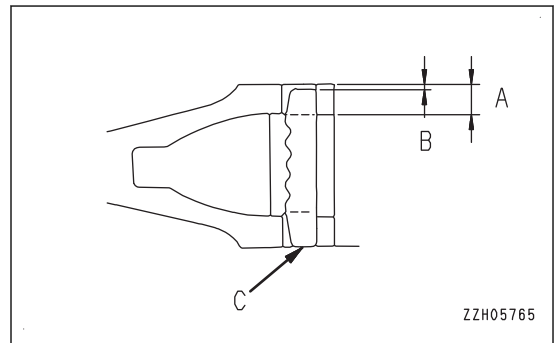

- The steel ball is about to come off.
Rubber (6) of rubber pin lock (3) is broken.

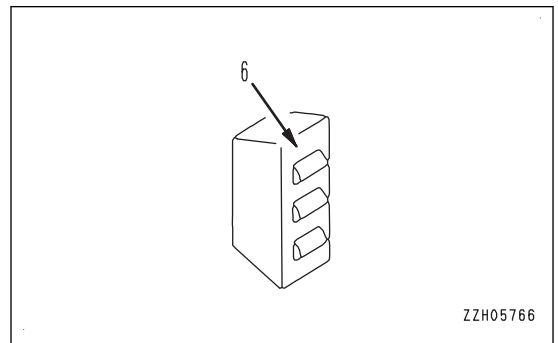

- The steel ball sinks.
Rubber (6) of rubber pin lock (3) is deteriorated and steel ball (7) sinks into it when you press the ball by hand.

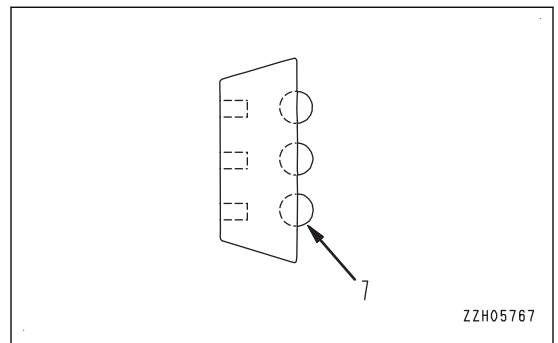

4. Remove the soil stuck to adapter (4) by using a putty knife.
5. Use your hand or a hammer to push rubber pin lock (3) into the hole of adapter (4).
When doing this, be careful that rubber pin lock (3) does not fly out from the adapter surface.
6. Clean the inside of bucket tooth (1), then install it to adapter (4).
If there is mud stuck to bucket tooth (1) or if there are protrusions, it will not enter adapter (4) properly, and there will not be proper contact at the mating part.

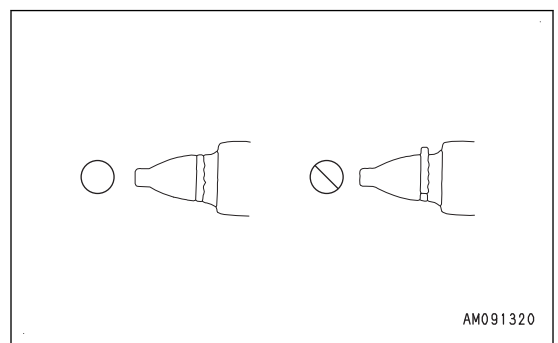

7. Fit the bucket tooth (1) to adapter (4), and check that when tooth (1) is pressed strongly, the rear face of the hole for the pin of bucket tooth (1) is at the same level as the rear face of the hole for the pin of adapter (4).

If the rear face of the pin hole of bucket tooth (1) protrudes in front of the rear face of the pin hole of adapter (4), do not drive the pin in.

There is sticking matter (D) which prevents the bucket tooth (1) from fitting into adapter (4) perfectly.

Find out and remove the sticking matter and fit the bucket tooth (1) into adapter (4) sufficiently, and then drive in the lock pin (2).

8. Insert the lock pin (2) in the pin hole in bucket tooth (1), and drive it in so that the top surface of lock pin (2) is the same height as the surface of bucket tooth (1).

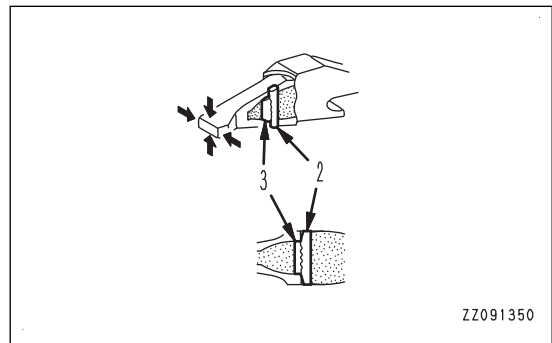
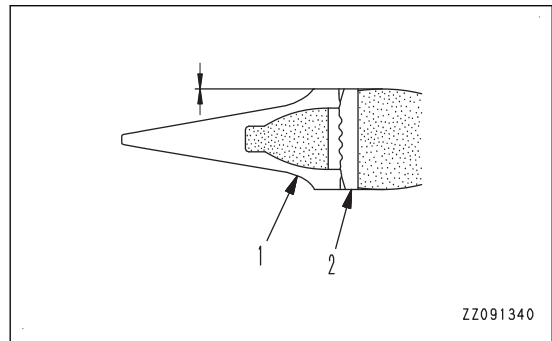
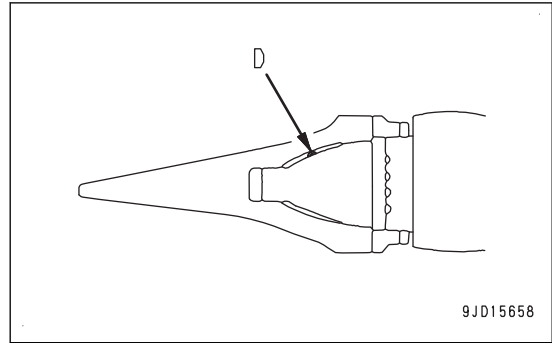

9. After replacing a bucket tooth, always check the following.
- After the lock pin (2) is driven in completely, its tip surface is flush with the surface of bucket tooth (1).
 - Lightly hit the lock pin (2) in the reverse direction from which it was hit in.
 - Lightly hit the tip of bucket tooth (1) from above and below, and hit its sides from right and left.
 - Rubber pin lock (3) and lock pin (2) are set as shown in the figure.

REMARK

- Turn over the bucket tooth and use it.
By doing so, the wear will become uniform. This will extend the service life of the tooth and reduce the frequency of replacement.
- When replacing the bucket tooth, replace the rubber pin lock and lock pin with new ones at the same time. This will prevent the bucket tooth from falling off.

METHOD FOR CHECKING WINDOW WASHER FLUID LEVEL, ADDING FLUID

(Machine with cab specification)

If the window washer fluid does not come out, check the fluid level in the window washer tank.

1. Open dirt cover (1).

Open dirt cover (1) fully and it will be secured by cover support lever (2).

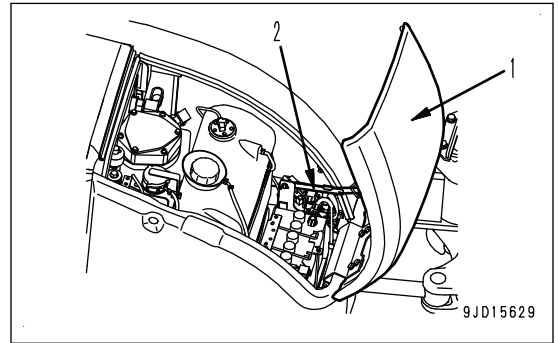

2. Check the fluid level in the window washer tank.

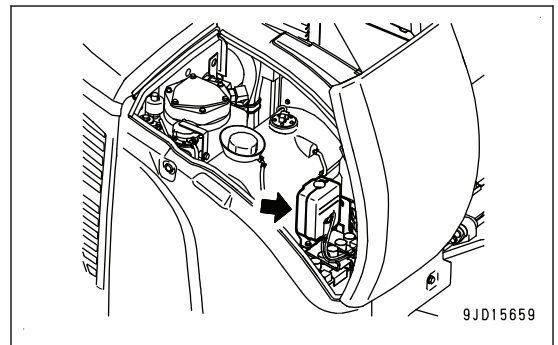

3. If the level is low, add window washer fluid for automobile.

Be careful not to let dirt or dust get in when adding fluid.

When adding the window washer fluid, use line (H) marked on the window washer tank as a guideline.

If the window washer fluid is added over the guideline, it may leak.

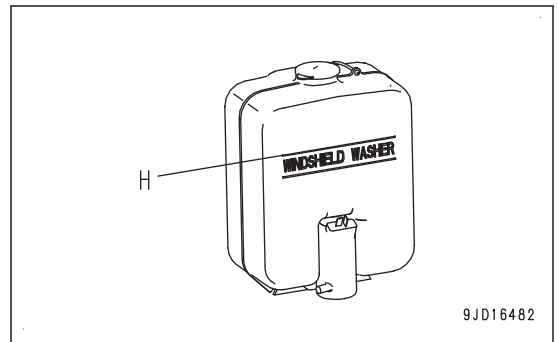

Mixing proportion of pure window washer fluid and water

The proper mixing proportion varies with the ambient temperature. Add the window washer fluid diluted with water at the following proportion.

Area, season	Mixing proportion	Freezing temperature
Normal	Washer fluid 1/3: water 2/3	-10 °C {14 °F}
Winter in cold district	Washer fluid 1/2: water 1/2	-20 °C {-4 °F}
Winter in extremely cold district	Pure washer fluid	-30 °C {-22 °F}

There are 2 types depending on the freezing temperature: -10 °C {14 °F} (general use) and -30 °C {-22 °F} (cold district use), select according to the area and season.

4. Close dirt cover (1).

METHOD FOR CHECKING AND MAINTENANCE AIR CONDITIONER

(Machine with cab specification)

CHECK AND MAINTENANCE ITEMS

Some check and maintenance items of the air conditioner are to be performed periodically and the others are to be performed when required. Perform the check and maintenance according to the following list, and use the air conditioner effectively.

Check and maintenance items	Content of check, maintenance	Guideline for maintenance interval
Refrigerant (gas)	Charge amount	Twice a year (spring, autumn)
Air conditioner condenser	Clogged fins	Every 500 hours "METHOD FOR CHECKING AND CLEANING RADIATOR FINS, OIL COOLER FINS, FUEL COOLER FINS, AND AIR CONDITIONER CONDENSER FINS"
Air conditioner compressor	Operating condition	Every 4000 hours
V-belt	Damage, tension	Every 250 hours "METHOD FOR CHECKING AND ADJUSTING AIR CONDITIONER COMPRESSOR BELT TENSION"
Blower motor, fan	Operating condition (Check for unusual noise)	When required
Control mechanism	Operating condition (Check that function is normal)	When required
Piping mounts	Mounting condition, looseness at tightening or connecting portions, leakage of gas, damage	When required

Even during the off-season, operate the air conditioner for 3 to 5 minutes once a month to maintain the oil film at all parts of the air conditioner compressor.

TEST THE LEVEL OF REFRIGERANT FOR AIR CONDITIONER (GAS)

⚠ WARNING

- **Never touch the refrigerant.**
Do not loosen any part of the refrigerant circuit.
If the refrigerant used in the air conditioner gets into your eyes or is splashed on your hands, it may cause loss of sight or frostbite.
- **Do not bring any open flame close to any point where the refrigerant (gas) is leaking.**

If the level of the refrigerant (gas) is low, the cooling effect will be reduced. Perform the check while running the engine at high idle and operating the air conditioner at high speed.

Check the condition of the refrigerant gas (Hydrofluorocarbons HFC-134a) that circulates the refrigerant circuit, through the sight glass (1) (inspection window) of the receiver.

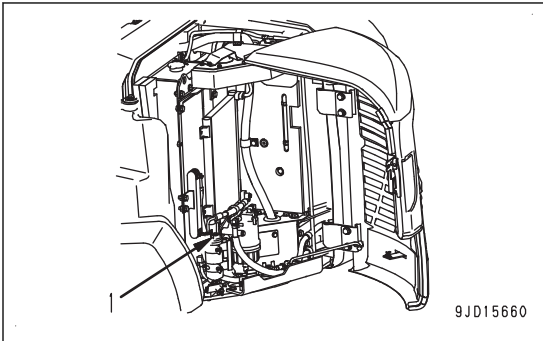

(A) Proper

No bubbles in refrigerant flow

(B) Insufficient

Some bubbles in refrigerant flow (bubbles pass continuously)

(C) None

Transparent with no color

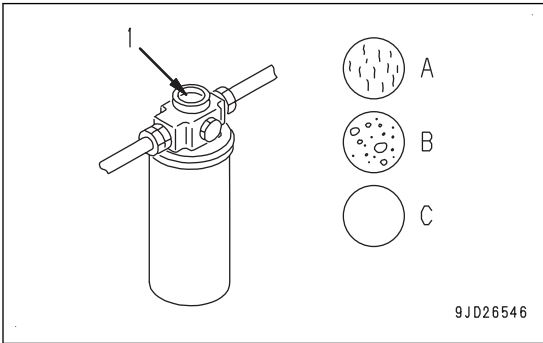

REMARK

When there are bubbles, the refrigerant (gas) level is low, so ask your Komatsu distributor to add refrigerant. If the air conditioner continues to run with low refrigerant (gas) level, it will cause damage to the compressor.

METHOD FOR LUBRICATING BOOM SWING CYLINDER FOOT PIN

Items to be prepared

- Grease pump
- Cloth

1. Pull engine rear cover (1) toward you to open it.
Open engine rear cover (1) fully and it is secured by rod (2).

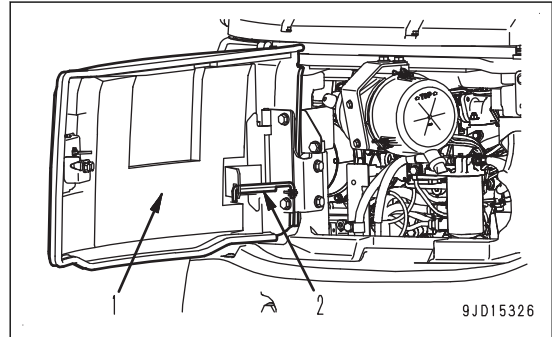

2. Pull cooling cover (3) toward you to open it.

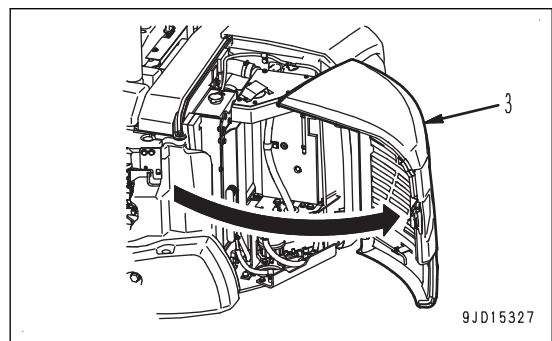

3. Turn rod (4) to LOCK position (L), and fix cooling cover (3) with the rod.

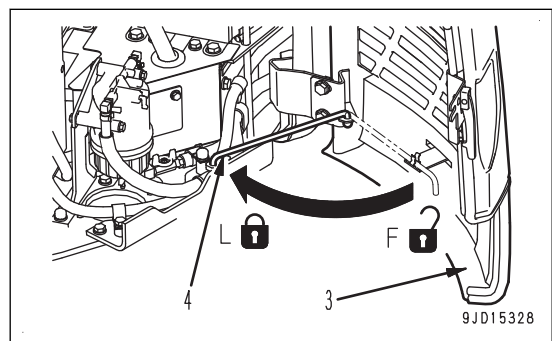

4. Loosen bolts (5) and remove cover (6).

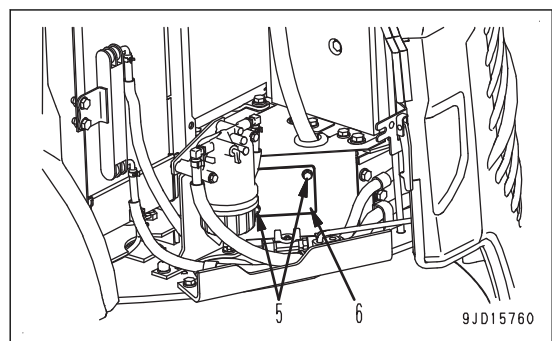

5. By using a grease pump, pump in grease through grease fittings (7).
6. After greasing, wipe off any old grease that is pushed out.
7. Install cover (6) with bolts (5).
8. Turn rod (4) to FREE position (F), and close cooling cover (3).
9. Close engine rear cover (1).

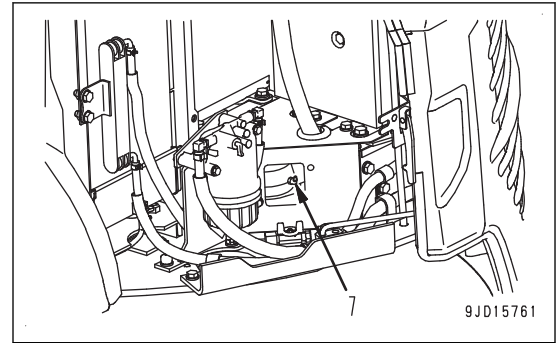

METHOD FOR WASHING WASHABLE FLOOR

⚠ WARNING

- Select a firm flat place for work.
- If the control levers or control pedals are touched by mistake, there is danger that the machine may suddenly move and cause serious personal injury or death.
Always set the lock lever securely to LOCK position before leaving the operator's seat.

On the washable cab floor, it is possible to flush out the dirt directly with water.

METHOD FOR CLEANING CAB FLOOR

NOTICE

Do not let the machine monitor, connectors, air conditioner and the filters inside the operator cab get wet during the cleaning.

1. Start the engine.
2. Set the lock lever to FREE position (F).
Be sure to operate the lock lever by the operating portion on the top.
3. Place the machine on a firm, level ground.
4. Lower the work equipment to the ground and set the machine in a stable condition.
 - 1) Operate the work equipment control levers to make the bucket bottom level and lower it to the ground.
 - 2) Push the blade control lever forward to lower the blade to the ground.
5. Set the lock lever to LOCK position (L).
Be sure to operate the lock lever by the operating portion on the top.
6. Stop the engine.
7. Flush out the dirt on the floor directly with water.

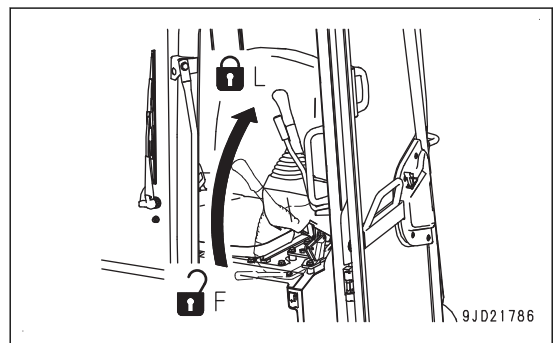
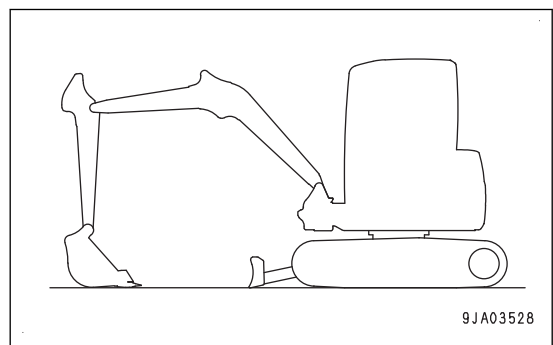
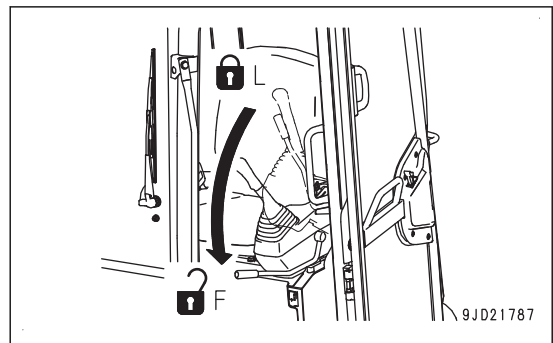
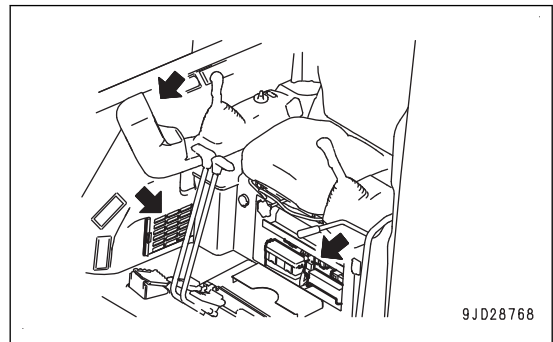

METHOD FOR CHECKING GAS SPRING

⚠ WARNING

The gas spring is charged with high-pressure nitrogen gas, so improper handling may cause an explosion resulting in serious personal injury or death. When handling, always observe the following.

- Do not disassemble.
- Do not bring open flame close to it or do not dispose of it in fire.
- Do not perform drilling, welding or flame-cutting.
- Do not hit or roll it, or subject it to any impact.
- When disposing of it, the gas must be released. Ask your Komatsu distributor to perform this work.

Gas springs are installed inside the left console (1 place), at the cab front window (1 place each on right and left), and under the floor (1 place).

In the following cases, ask your Komatsu distributor for inspection, repair, and replacement.

- It is heavy to pull up the lock lever, or to open the cab front window and the floor.
- The lock lever does not stay at LOCK position.
- Oil or gas is leaking from the gas spring.

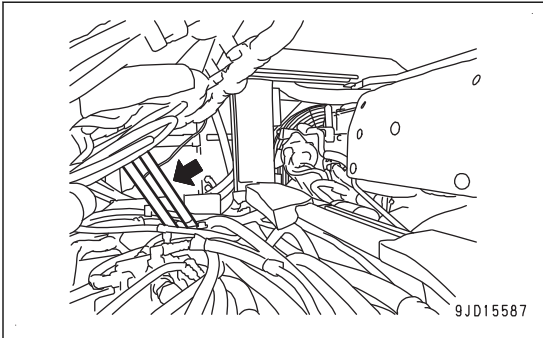
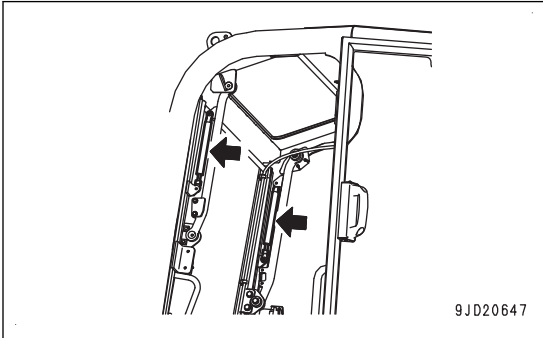
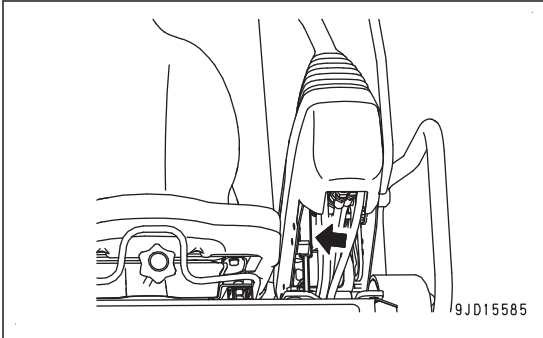

METHOD FOR BLEEDING AIR FROM HYDRAULIC CIRCUIT

METHOD FOR BLEEDING AIR FROM PUMP

NOTICE

Abnormal heat will be generated if the pump is operated without filling the pump case with hydraulic oil. It may cause a premature damage to the pump. Bleed air securely.

1. Open the dirt cover (1).
Open the dirt cover (1) fully and it will be secured by the cover support lever (2).

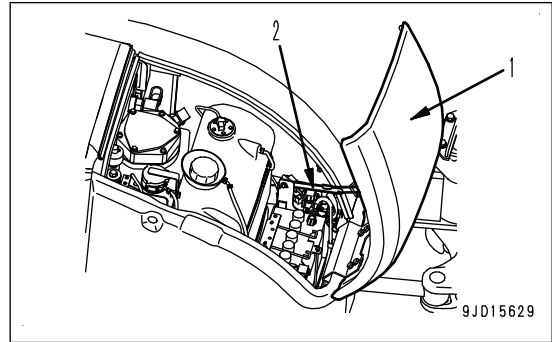

2. Loosen the bolt (3) of the hydraulic tank, move the plate (4) on the oil filler port (F), and turn the cap of the oil filler port (F) slowly to remove it.
Release the internal pressure.

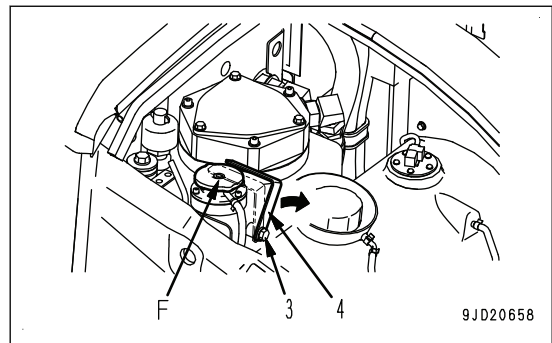

3. Remove the bolts (5) (M10, 3 pieces), and remove the triangle cover (6).

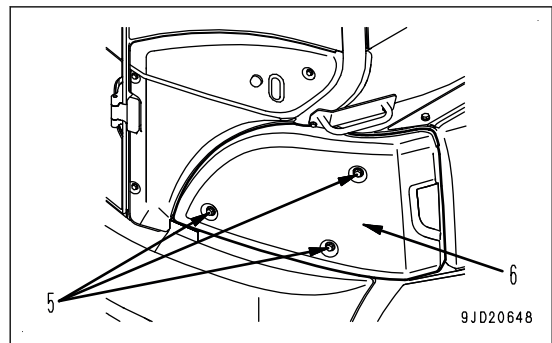

4. Remove the bolts (7), and remove the bracket (8).

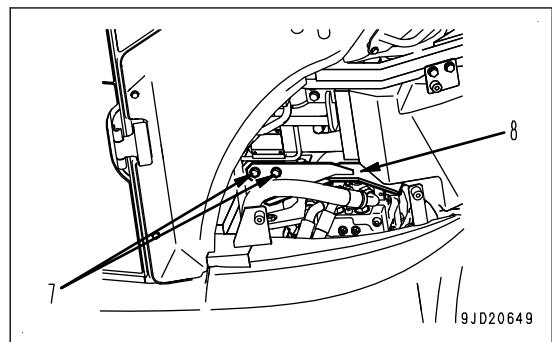

5. Loosen the bleeder (9).
When the oil in which air is not mixed oozes out of bleeder (9), air bleeding is completed.
6. After bleeding air, tighten the bleeder (9).
7. Install the bracket (8) with bolts (7).
8. Tighten the cap of oil filler port (F) on the hydraulic tank.
9. Return the plate (4) on the oil filler port (F) of the hydraulic tank to its original position, and fix it with bolt (3).
10. Install the triangle cover (6) with bolts (5) (M10, 3 pieces).
11. Start the engine.
12. Turn the fuel control dial to Low idle (MIN) position (a).
Run the engine at low idle for approximately 10 minutes.

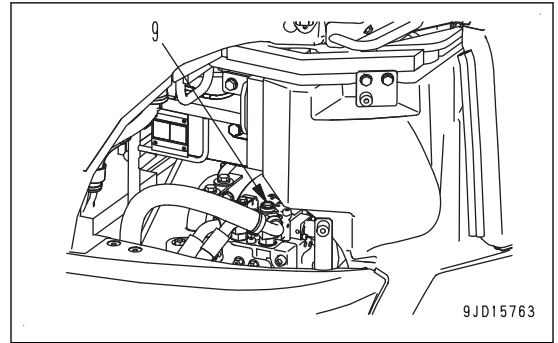

9JD15763

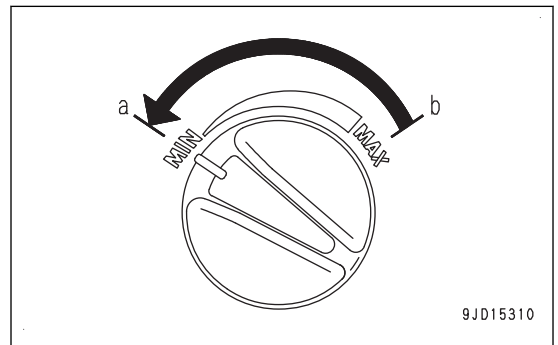

9JD15310

The air bleeding of pump is completed.

Proceed to the next operation.

METHOD FOR BLEEDING AIR FROM CYLINDER

NOTICE

If the engine runs at high speed immediately after the startup, or if a cylinder is pushed up to its stroke end, the air mixed into the cylinder may cause damage to the piston packing, etc.

If air is bled while the cap of the oil filler port (F) of the hydraulic tank is kept closed, negative pressure is generated inside the hydraulic tank, and it may adversely affect the piping.

1. Open the dirt cover (1).
Open the dirt cover (1) fully and it will be secured by the cover support lever (2).

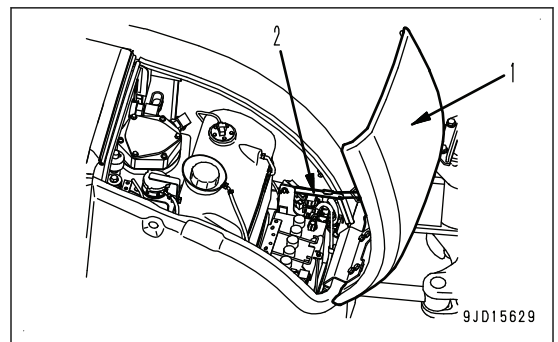

9JD15629

2. Loosen the bolt (3) of the hydraulic tank, move the plate (4) on the oil filler port (F), and turn the cap of the oil filler port (F) slowly to remove it.
Release the internal pressure.
3. Start the engine.

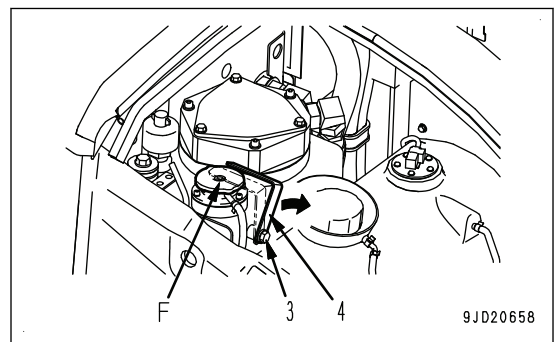

9JD20658

- 4. Turn the fuel control dial to Low idle (MIN) position (a).
- 5. Operate each cylinder of the work equipment to approximately 100 mm {approximately 3.9 in} before the stroke end 4 to 5 times.
Take care not to move the cylinder to the stroke end.

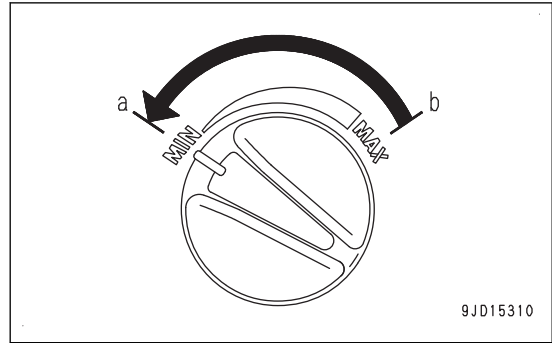

- 6. Turn the fuel control dial to High idle (MAX) position (b).
- 7. Operate each cylinder of the work equipment to approximately 100 mm {approximately 3.9 in} before the stroke end 4 to 5 times.
Take care not to move the cylinder to the stroke end.

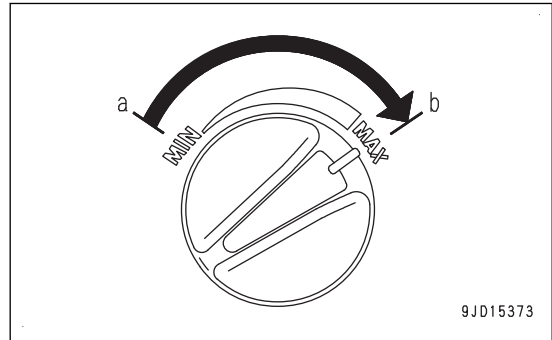

- 8. Turn the fuel control dial to Low idle (MIN) position (a).
- 9. Operate each cylinder to the end of its stroke, and relieve it to remove the air completely.

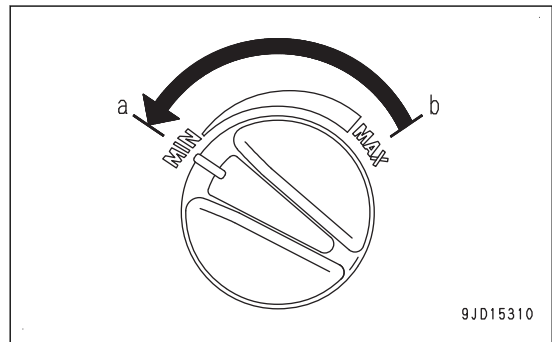

- 10. Operate the work equipment control levers, and extend the boom cylinder, bucket cylinder, and arm cylinder to their stroke end.
Set the work equipment in the posture shown in the figure.

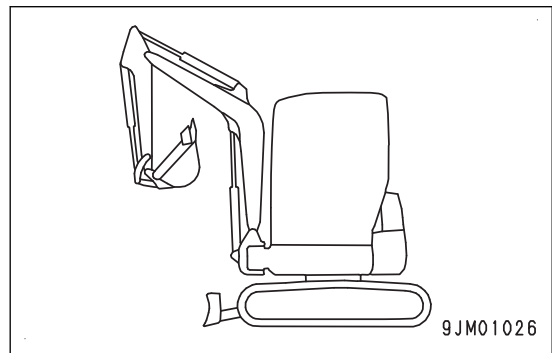

- 11. Set the lock lever securely to LOCK position (L).
Be sure to operate the lock lever by the operating portion on the top.
- 12. Stop the engine.
- 13. Tighten the cap of oil filler port (F) on the hydraulic tank securely.
By doing so, the hydraulic tank is pressurized.

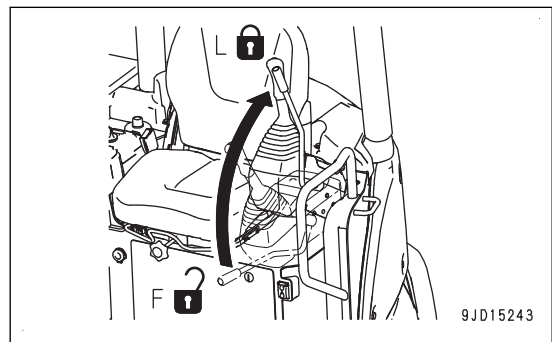

NOTICE

If the hydraulic tank is not pressurized, air is sucked in the pump and it affects the components badly.

- 14. Return the plate (4) on the oil filler port (F) of the hydraulic tank to its original position, and fix it with bolt (3).

15. Close the dirt cover (1).

METHOD FOR BLEEDING AIR FROM ATTACHMENT

(When the machine is equipped with attachment)

NOTICE

- If the method of air bleeding from the attachment is specified by the manufacturer, bleed the air according to the specified procedure.
- After completing the air bleeding operation, stop the engine, and leave the machine for 5 minutes before starting operations. This will remove the air bubbles in the oil inside the hydraulic tank.

If a breaker or other attachment is installed, perform the air bleeding procedure until the air is completely bled from the attachment circuit.

1. Turn the fuel control dial to Low idle (MIN) position (a).
2. Repeat operating the attachment approximately 10 times to bleed air.
3. Check that there is no leakage of oil and wipe off any oil that is spilled.
4. After bleeding air, check the oil level in the hydraulic tank.

If the oil level in the hydraulic tank is insufficient, add it.

For the method to check the oil level in the hydraulic tank, see "METHOD FOR CHECKING OIL LEVEL IN HYDRAULIC TANK, ADDING OIL".

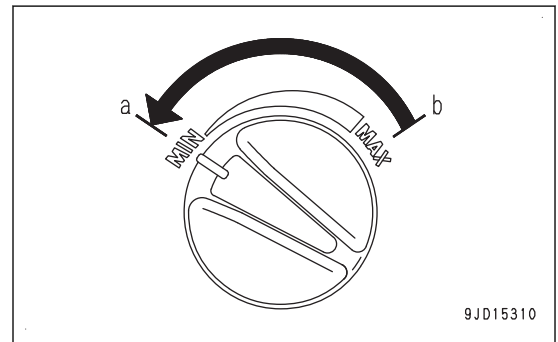

METHOD FOR CHECKING SWING PINION GREASE LEVEL, ADD GREASE**⚠ WARNING**

The opening and closing (tilting) operation of the floor is necessary when performing this maintenance, and it may cause serious personal injury or death.

Before opening and closing of the floor, thoroughly read "METHOD FOR OPENING AND CLOSING FLOOR UNIT", and then start the operation, or ask your Komatsu distributor to perform the work.

1. Open the floor.
For details, see "METHOD FOR OPENING FLOOR UNIT".
2. Remove the bolts (1) (2 pieces) on top of the revolving frame, and remove the cover (2).
3. Check that the grease is filled.
4. Check that the grease is not milky white.
Total amount of grease: 4.5 ℓ {1.19 U.S.Gal} (4.1 kg {9.04 lb})
If the grease is milky white, it needs to be replaced. Ask your Komatsu distributor to replace it.
5. Install the cover (2) with bolts (1).
6. After the adjustment is completed, close the floor.
For details, see "METHOD FOR CLOSING FLOOR UNIT".

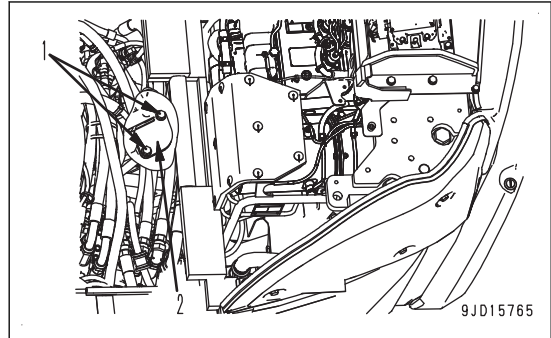

CHECKS BEFORE STARTING

For the following items, see OPERATION, "METHOD FOR CHECKING BEFORE STARTING".

- Drain water and sediment from fuel tank
- Check dust indicator
- Check water separator, drain water and sediment
- Check oil level in hydraulic tank, add oil
- Check coolant level, add coolant
- Check oil level in engine oil pan, add oil
- Check electric wiring
- Check fuel level, add fuel
- Check horn
- Check floor tilt fixing bolt

EVERY 100 HOURS MAINTENANCE

METHOD FOR LUBRICATING

METHOD FOR LUBRICATING SWING SYSTEM

WARNING

Never swing the upper structure while greasing swing circle and swing pinion.

NOTICE

Perform greasing every 10 hours for the first 100 hours operation on a new machine.

Items to be prepared

Grease pump

1. By using a grease pump, pump in grease through the grease fittings shown by arrows.
 - (1) Swing pinion (1 place)
 - (2) Swing circle (1 place)
2. Check visually that the greasing has been performed properly.

When greasing swing circle and swing pinion, swing the upper structure little by little to change the position so that the whole circumference will be greased.

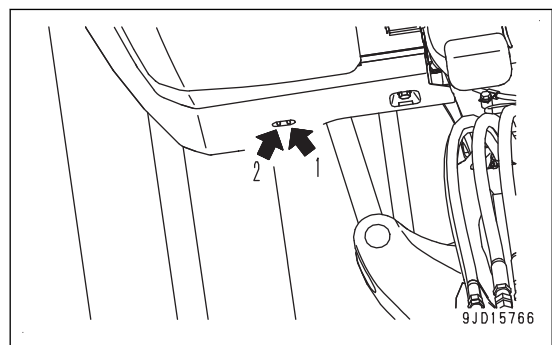

METHOD FOR LUBRICATING WORK EQUIPMENT

NOTICE

- If any unusual noise is generated from any greasing point, perform the greasing regardless of the greasing interval.
- Perform greasing every 10 hours for the first 100 hours operation on a new machine.
- After the machine is subjected to digging work in the water, be sure to grease the wet pins.

Items to be prepared

Grease pump

1. Set the machine in the greasing posture shown in the figure.

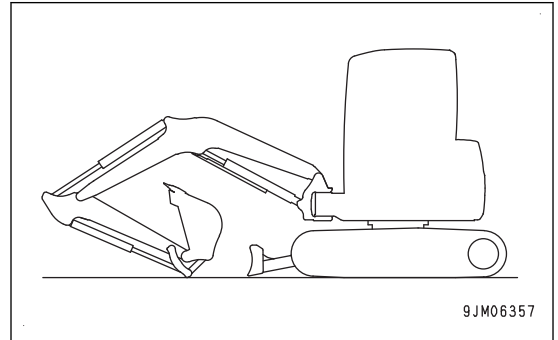

- 1) Start the engine and run it at low idle.

- 2) Set the lock lever to FREE position (F).

Be sure to operate the lock lever by the operating portion on the top.

- 3) Push the blade control lever forward to lower the blade to the ground.

- 4) Operate the work equipment control levers to extend bucket cylinder and arm cylinder to their stroke end, and then lower the boom gently.

Lower the bucket link to the ground.

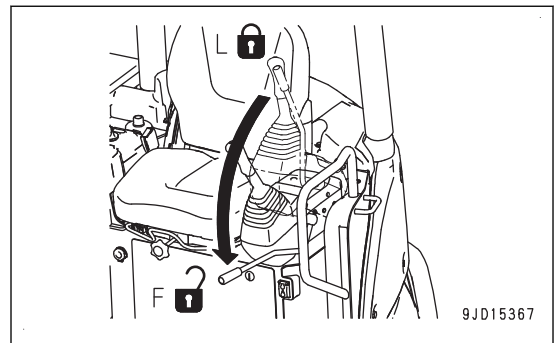

- 5) Set the lock lever securely to LOCK position (L).

Be sure to operate the lock lever by the operating portion on the top.

- 6) Stop the engine, and remove the starting switch key.

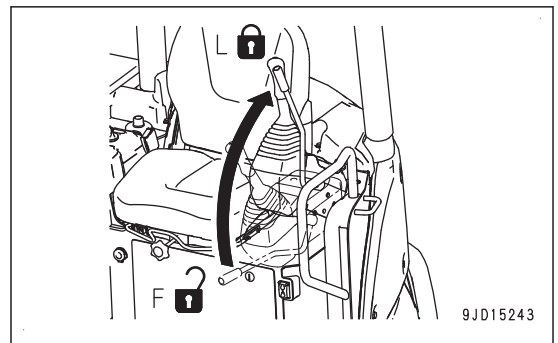

2. Pump in the grease through the grease fittings shown by arrows by using a grease pump.

- (1) Bucket and link connection pin (1 place)
- (2) Arm and bucket connection pin (1 place)
- (3) Arm and link connection pin (1 place)
- (4) Bucket cylinder rod end (1 place)
- (5) Link connection pin (1 place)

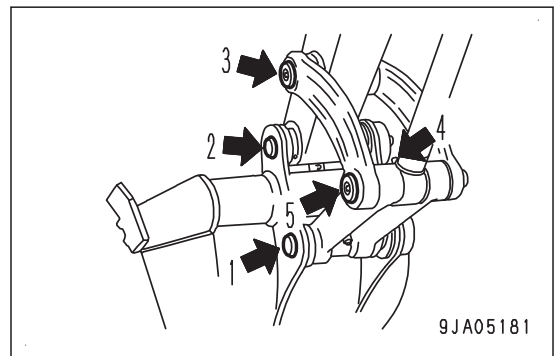

- (6) Blade cylinder foot pin (1 place)
- (7) Blade cylinder rod end (1 place)
- (8) Blade foot pin (2 places)
- (9) Boom cylinder foot pin (1 place)

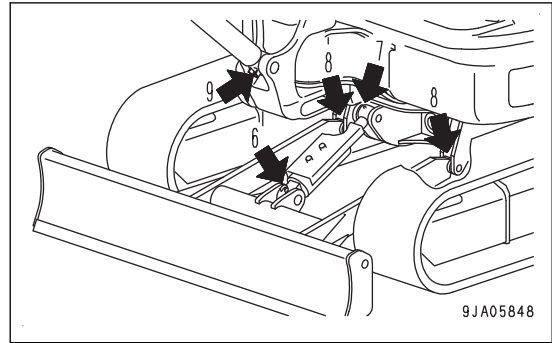

- (10) Boom swing bracket pin (2 places)
- (11) Boom swing cylinder rod end pin (1 place)
- (12) Boom foot pin (2 places)

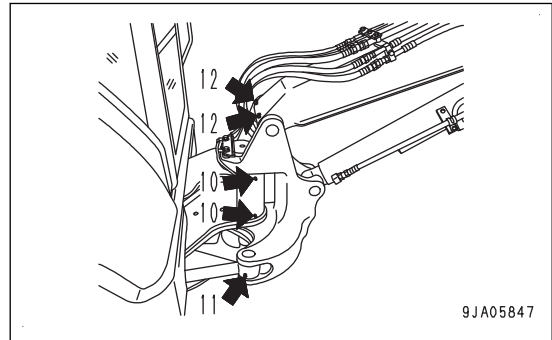

- (13) Boom cylinder rod end (1 place)
- (14) Arm cylinder foot pin (1 place)

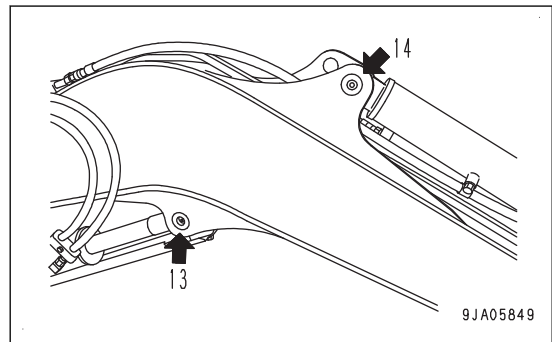

- (15) Arm cylinder rod end (1 place)
- (16) Boom and arm connection pin (1 place)
- (17) Bucket cylinder foot pin (1 place)

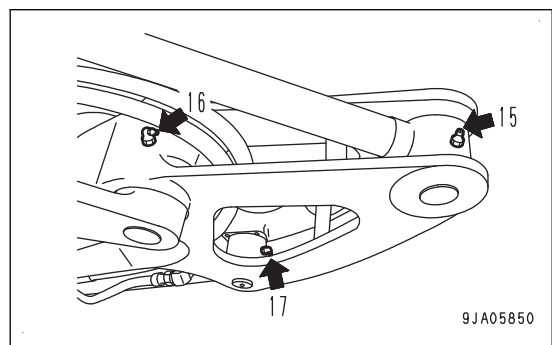

REMARK

For the greasing to boom swing cylinder foot pin, it is the item to be performed in “WHEN REQUIRED”.

3. Check visually that the greasing has been performed properly.
4. After greasing, wipe off any old grease that is pushed out.

EVERY 250 HOURS MAINTENANCE

METHOD FOR CHECKING AND ADJUSTING AIR CONDITIONER COMPRESSOR BELT TENSION

(Machine with cab specification)

1. Pull engine rear cover (1) toward you to open it.
Open engine rear cover (1) fully and it is secured by rod (2).

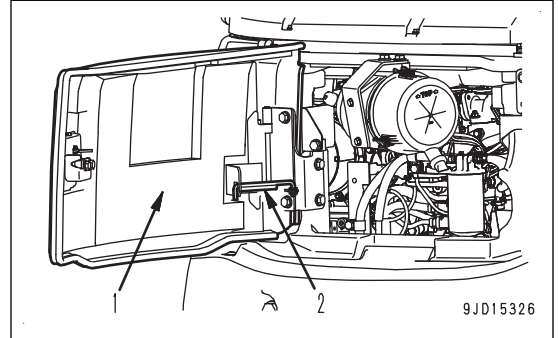

2. Check the belt tension of air conditioner compressor

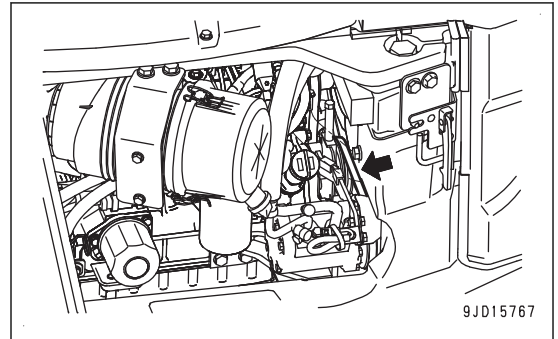

Press the belt with a finger at a point midway between idle pulley (3) and compressor (4). (approximately 58.8 N {approximately 6.0 kg})

If deflection (a) is in the standard range (5 to 6 mm {0.197 to 0.236 in}), the air conditioner compressor belt tension is correct.

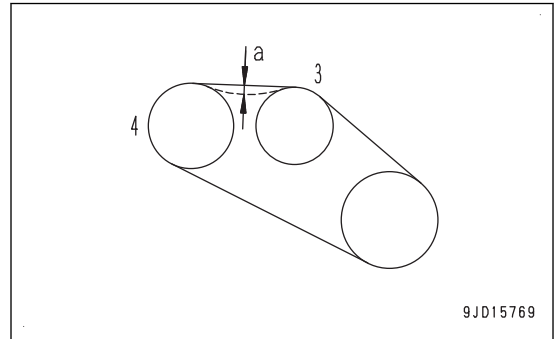

If deflection (a) is out of the standard range, adjust it according to the following procedure.

- 1) Loosen bolts (5) (M10, 4 pieces) and remove under-cover (6).

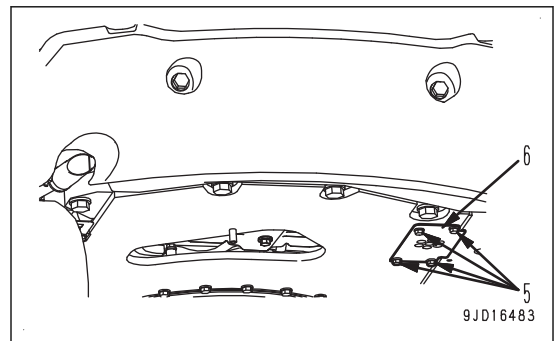

- 2) Loosen nut (7).
- 3) Adjust with adjustment nut (8) of idle pulley (3).
- 4) Tighten nut (7) to fix idle pulley (3).
- 5) Check the belt tension of air conditioner compressor again.

If the tension is not correct, adjust it again.

- 6) Check each pulley for breakage and wear of the V-groove and check the V-belts for wear.

In particular, check carefully that the V-belt is not in contact with the V-groove bottom.

If the V-belt is stretched and has no allowance for adjustment, or has slipping sound or squeak because of cuts or cracks of the belt, ask your Komatsu distributor to replace it.

When the new V-belt is installed, readjust it after operating for 1 hour.

- 7) Install undercover (6) with bolts (5) (M10, 4 pieces).

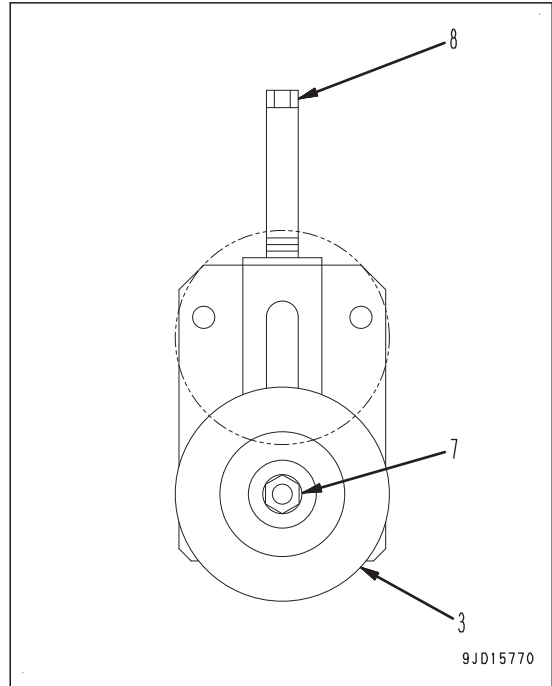

- 3. Close engine rear cover (1).

METHOD FOR CLEANING AIR CONDITIONER RECIRC AIR FILTER

(Machine with cab specification)

⚠ WARNING

When using the compressed air, there is a danger that dirt may scatter and cause personal injury. Wear the protective equipment such as the protective eyeglasses and dust mask.

NOTICE

- As a guideline, the filters should be cleaned every 250 hours, but on dusty jobsites, clean the filters more frequently.
- Before cleaning the recirculation air filter, stop the air conditioner.

- 1. Take out the recirculation air filter (1).
Pull out the recirculation air filter (1) forward to remove it.
- 2. Clean the recirculation air filter (1) with compressed air.
 - If there is oil on the recirculation air filter (1), or if the filter is extremely dirty, wash it in a neutral detergent. After rinsing it in water, dry it thoroughly before using it again.
 - Replace the recirculation air filter with a new one every year. If the clogging of the recirculation air filter (1) cannot be removed by blowing with compressed air or washing in water, replace the filter immediately.

- 3. Restore the recirculation air filter (1).

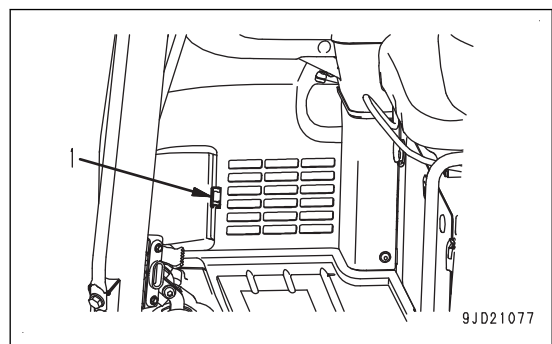

EVERY 500 HOURS MAINTENANCE

Maintenance for every 100 and 250 hours should be performed at the same time.

METHOD FOR CHANGING OIL IN ENGINE OIL PAN, REPLACING ENGINE OIL FILTER CARTRIDGE

⚠ WARNING

Immediately after the engine is stopped, its parts and oil are still very hot, and may cause burn injury. Wait for the temperature to go down, and then start the work.

Refill capacity of oil pan: 7.5 l {1.98 U.S.Gal}

Items to be prepared

- Container to catch drained oil
 - Filter wrench
1. Place the oil container under the drain plug (P) to catch the drained oil.
 2. Remove the drain plug (P) slowly to drain the oil so that you do not get splashed with the oil.
 3. Check the drained oil.
If there are excessive metal powder or foreign material, contact your Komatsu distributor.
 4. Install the drain plug (P).

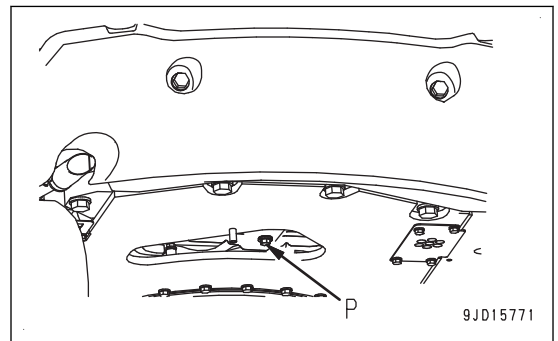

5. Pull the engine rear cover (1) backward to open it.
Open the engine rear cover (1) fully and it is secured by rod (2).

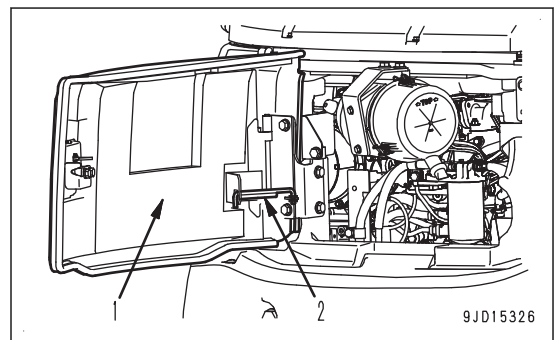

6. Turn the engine oil filter cartridge (3) counterclockwise by using the filter wrench, and remove it.
7. Clean the mounting face of engine oil filter cartridge.

REMARK

Check that the old packing does not stick to the mounting face of engine oil filter cartridge. If there is any old packing stuck to the filter, it will cause oil leakage.

8. When installing the new engine oil filter cartridge, apply clean engine oil (or thin film of grease) to its packing and thread part.

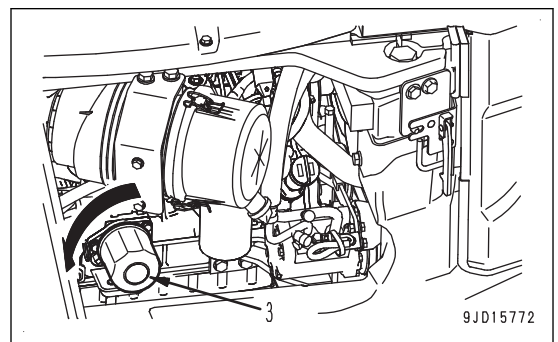

When installing, bring the packing surface into contact with the seal surface of engine oil filter cartridge, then tighten it a further 1/2 to 3/4 turns.

9. After replacing the engine oil filter cartridge, refill with the specified level of engine oil through oil filler port (F).
10. Run the engine at low idle for a while and then stop it.
11. Check the oil level in the engine oil pan.
Check that the oil level is between H and L marks on dipstick (G).
12. Close the engine rear cover (1).

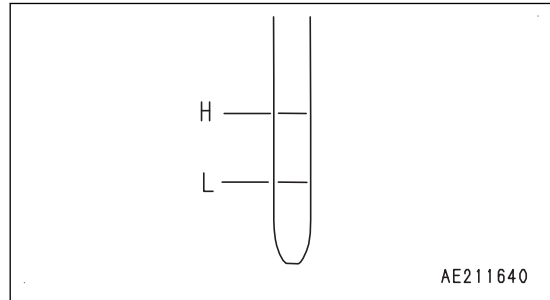
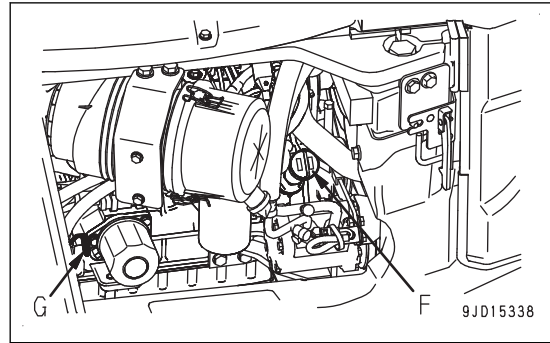

METHOD FOR REPLACING FUEL PREFILTER ELEMENT

⚠ WARNING

- Immediately after the engine is stopped, the parts are still very hot. Do not replace the filter immediately.
Wait for all of parts to cool down before starting the work.
- High pressure is generated inside the engine fuel piping system when the engine is running. When replacing the filter, wait for at least 30 seconds after stopping the engine to let the internal pressure go down before replacing the filter.
- Do not bring any open flame close.

NOTICE

- Komatsu genuine fuel prefilter element uses a special filter that has highly efficient filtering ability. When replacing the parts, Komatsu recommends using Komatsu genuine parts.
- The common rail fuel injection system used on this machine consists of more precise parts than those in the conventional injection pump and nozzles.
If any fuel prefilter element other than a Komatsu genuine part is used, foreign material may get in and cause problems with the injection system.
Never use a substitute.
- When performing inspection and maintenance of the fuel system, be careful not to let any dirt or dust get in, more than ever before.
If dust sticks to the fuel system, wash it off thoroughly with fuel.

Items to be prepared

- Container to catch the fuel
- Cloth

1. Set the machine in the posture shown in the figure.
 - 1) Start the engine.

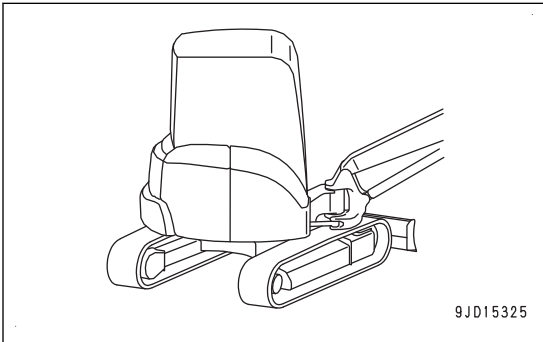

- 2) Set the lock lever to FREE position (F).
Be sure to operate the lock lever by the operating portion on the top.
- 3) Operate the work equipment control lever slowly to the right and left to swing the upper structure so that the fuel prefilter comes between the tracks.
- 4) Operate the work equipment control levers, and lower the work equipment to the ground.

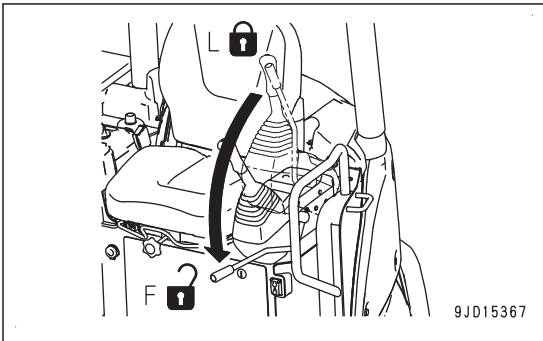

- 5) Set the lock lever to LOCK position (L).
Be sure to operate the lock lever by the operating portion on the top.
- 6) Stop the engine.

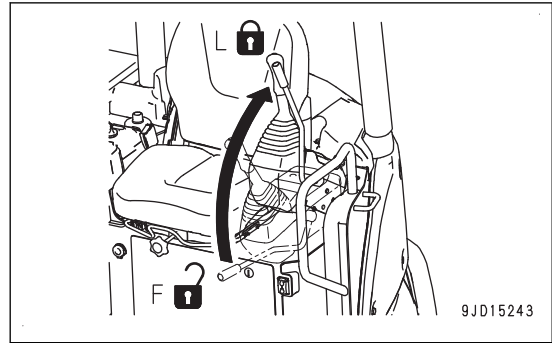

- 2. Pull the engine rear cover (1) backward to open it.
Open the engine rear cover (1) fully and it is secured by rod (2).

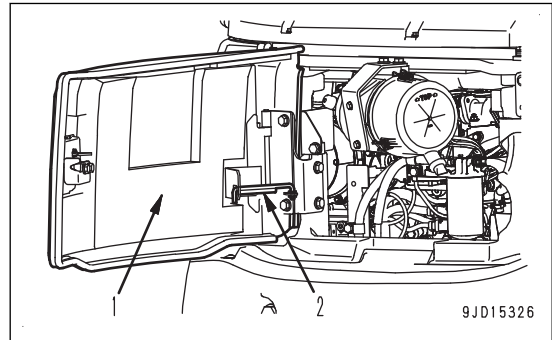

- 3. Pull the cooling cover (3) backward to open it.

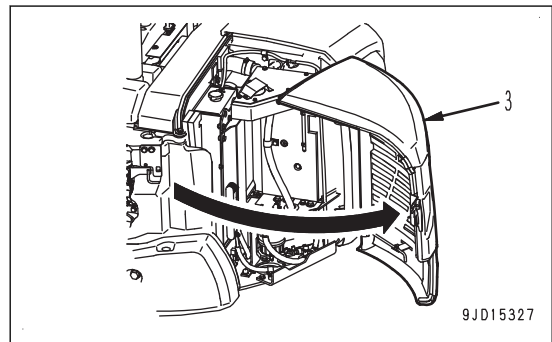

- 4. Turn the rod (4) to LOCK position (L), and fix the cooling cover (3) with the rod.

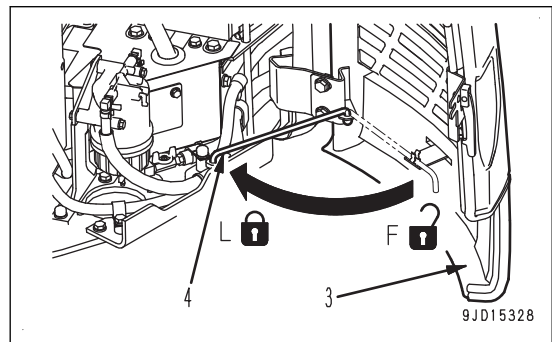

- 5. Loosen the bolts (5) and remove the undercover (6).
- 6. Place a container under the fuel prefilter to catch the fuel.

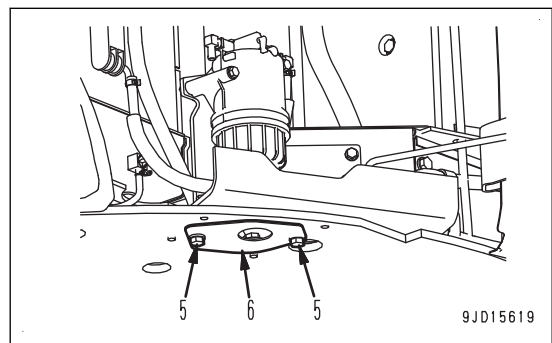

7. Turn the handle (7) to CLOSE position (S), and loosen the drain plug (8).
8. Drain the water until the red ring (9) contacts to the bottom of transparent cup (10).
9. Tighten the drain plug (8).

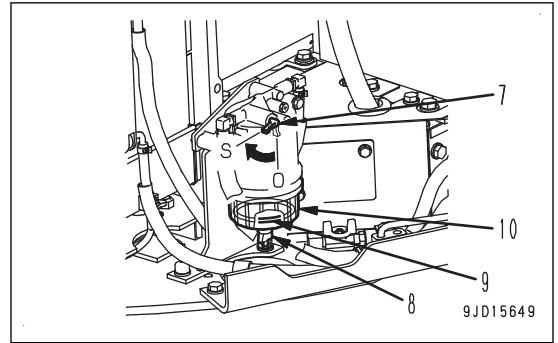

10. Turn the transparent cup (10) counterclockwise to remove it.
Remove the transparent cup (10) without spilling the fuel.
If the fuel spills, wipe them off with cloth thoroughly.
Be careful not to lose the red ring (9) in transparent cup (10).

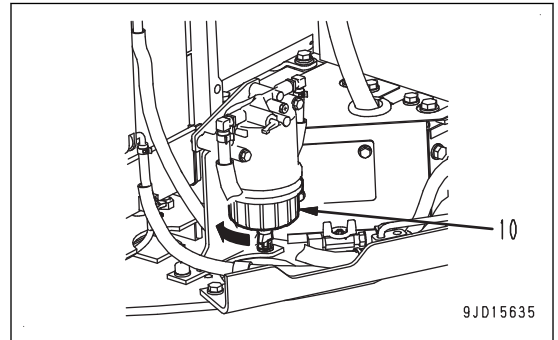

11. Remove the element (11) from top of the fuel prefilter, and replace it with a new element.
12. Clean the inside of transparent cup (10) with diesel fuel or flushing oil.
13. Install the element and O-ring (12) to transparent cup (10).
14. Insert the red ring (9) into transparent cup (10) and fill it with fuel.
15. Check the condition of O-ring (12) installed to transparent cup (10).

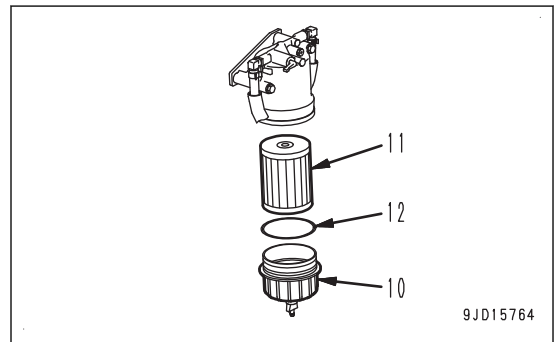

Replace the O-ring with a new one if needed.

16. Install the transparent cup (10) to top of fuel prefilter, and tighten it clockwise.
Tightening torque:
27 to 33 Nm {2.8 to 3.4 kgm, 19.9 to 24.4 lbft}

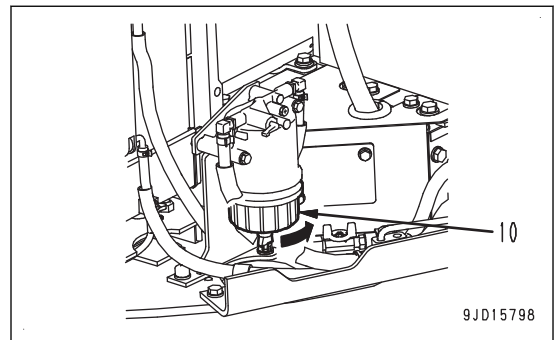

17. Turn the handle (7) to OPEN position (O).
18. Install the undercover (6) with bolts (5).
19. After replacement of the element is completed, bleed air from the fuel circuit.
For bleeding air, see "PROCEDURES FOR BLEEDING AIR FROM FUEL CIRCUIT".
20. Turn the rod (4) to FREE position (F), and close the cooling cover (3).
21. Close the engine rear cover (1).

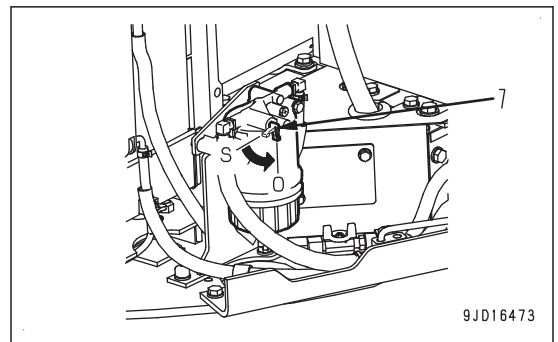

METHOD FOR REPLACING FUEL MAIN FILTER CARTRIDGE

WARNING

- Immediately after the engine is stopped, the parts are still very hot. Do not replace the fuel filter cartridge immediately.
Wait for all of parts to cool down before starting the work.
- High pressure is generated inside the engine fuel piping system when the engine is running. When replacing the fuel filter cartridge, wait for at least 30 seconds after stopping the engine to let the internal pressure go down before replacing the filter.
- Do not bring any open flame close.

NOTICE

- Komatsu genuine fuel filter cartridges use a special filter that has highly efficient filtering ability. When replacing the parts, Komatsu recommends using Komatsu genuine parts.
- The common rail fuel injection system used on this machine consists of more precise parts than those in the conventional injection pump and nozzles. If any cartridge other than a Komatsu genuine filter cartridge is used, dust or dirt may get in and cause problems with the injection system. Never use a substitute.
- When performing inspection and maintenance of the fuel system, be careful not to let any dirt or dust get in, more than ever before. If dust sticks to the fuel system, wash it off thoroughly with fuel.

Items to be prepared

- Filter wrench
- Container to catch the fuel
- Cloth

1. Pull the engine rear cover (1) backward to open it.
Open the engine rear cover (1) fully and it is secured by rod (2).

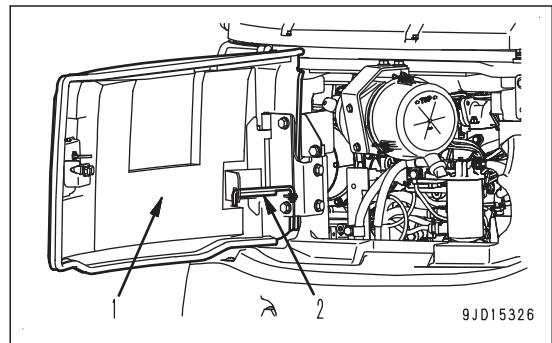

2. Pull the cooling cover (3) backward to open it.

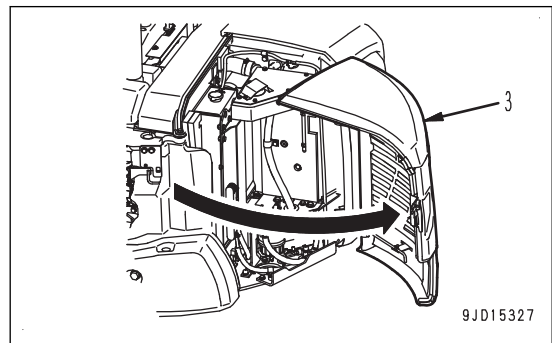

3. Turn the rod (4) to LOCK position (L), and fix the cooling cover (3) with the rod.

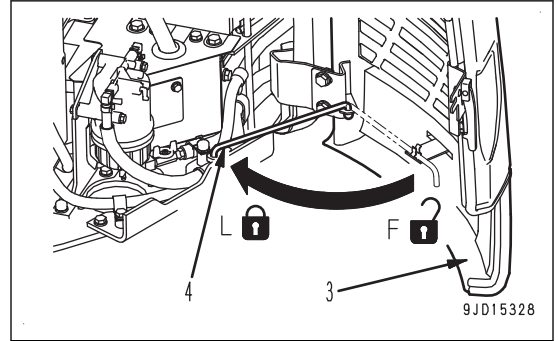

4. Turn the handle (6) of fuel prefilter (5) to CLOSE position (S).

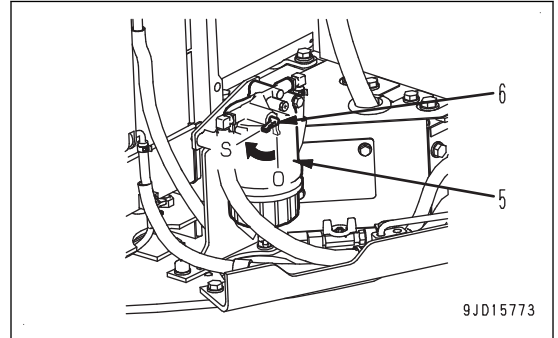

5. Place a container under the fuel filter to catch the fuel.

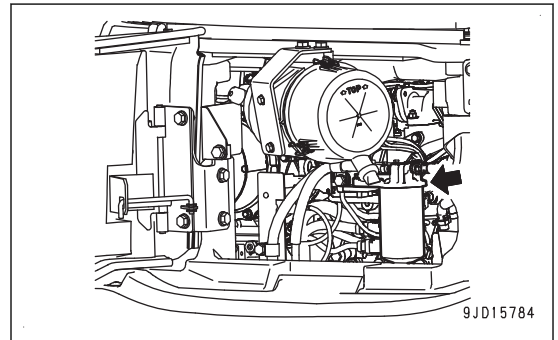

6. Turn the fuel filter cartridge (7) counterclockwise by using the filter wrench, and remove it.

After removing the fuel filter cartridge (7), fuel drips down from the fuel filter head.

In order to prevent flowing out of the fuel, be sure not to leave the machine with the fuel filter cartridge (7) removed.

7. Clean the mounting face of the fuel filter cartridge.
8. Apply thin film of fuel to the packing face.

Do not fill the new fuel filter cartridge with fuel.

9. Remove the cap (B) at center, and install the fuel filter cartridge to the mounting face of fuel filter cartridge.

When installing the fuel filter cartridge, turn it clockwise to bring the packing surface into contact with the seal surface of fuel filter cartridge, and then tighten it approximately 1 turn by using filter wrench.

Tightening torque:

19.6 to 23.5 Nm {2.0 to 2.4 kgm, 14.5 to 17.4 lbft}

If the fuel filter cartridge is tightened too far, the packing will be damaged and this will lead to leakage of fuel. If it is tightened too loose, fuel will also leak from the packing, so always tighten to the specified angle.

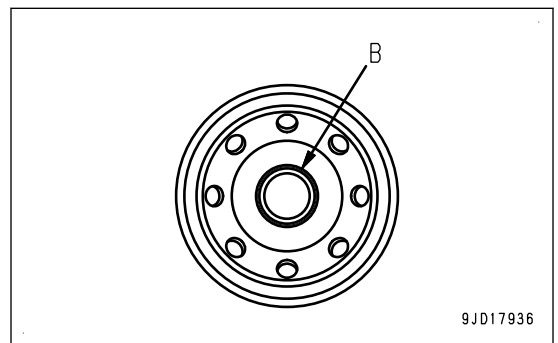
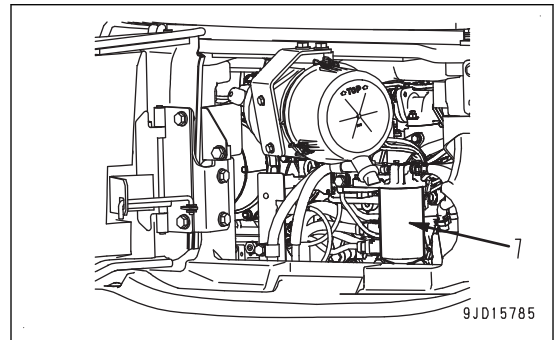

When tightening with a filter wrench, be extremely careful not to dent or damage the filter.

10. Turn the handle (6) of fuel prefilter (5) to OPEN position (O).

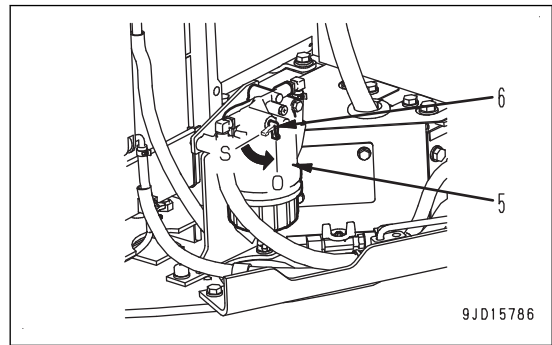

11. After completing the replacement of the fuel filter cartridge, bleed air from the fuel circuit.
For bleeding air, see "PROCEDURES FOR BLEEDING AIR FROM FUEL CIRCUIT".
12. After the air bleeding is completed, start the engine and run it at low idle for approximately 10 minutes.
13. Check the filter seal surface and the mounting face of the transparent cup for fuel leakage.
If the fuel leaks, check according to the following procedure.
- 1) Check the fastening condition of the fuel filter cartridge.
 - 2) If the fuel leaks, remove the fuel filter cartridge in steps 4 to 6.
 - 3) Check the packing surface for damage and pinching of foreign material.
If it has damage or pinching of foreign material, replace the fuel filter cartridge with a new one.
 - 4) Install the fuel filter cartridge in steps 7 to 11.
 - 5) Check the filter seal surface and the mounting face of the transparent cup for fuel leakage, and if the fuel leaks, check again.
14. Turn the rod (4) to FREE position (F), and close the cooling cover (3).
15. Close the engine rear cover (1).

METHOD FOR CHECKING AND CLEANING RADIATOR FINS, OIL COOLER FINS, FUEL COOLER FINS, AND AIR CONDITIONER CONDENSER FINS

⚠ WARNING

If the compressed air, high-pressure water, or steam hits your body directly or dirt is scattered by use of it, there is a danger of personal injury. Wear the protective equipment such as the protective eyeglasses and dust mask.

NOTICE

- When using compressed air for cleaning, blow it from some distance as perpendicular to the core as possible to avoid damaging the fins. Damage on the fins can cause water leakage and overheating.
- In a dusty job site, check the fins every day, regardless of the maintenance interval.

1. Pull the engine rear cover (1) backward to open it.
Open the engine rear cover (1) fully and it is secured by rod (2).

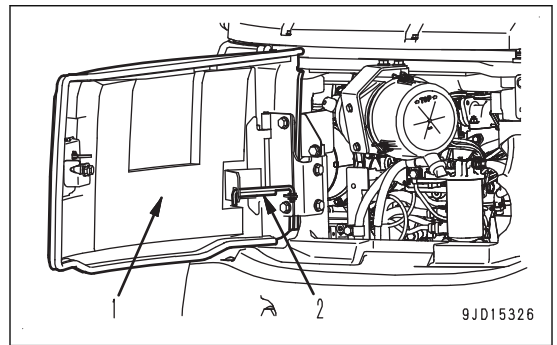

2. Pull the cooling cover (3) backward to open it.

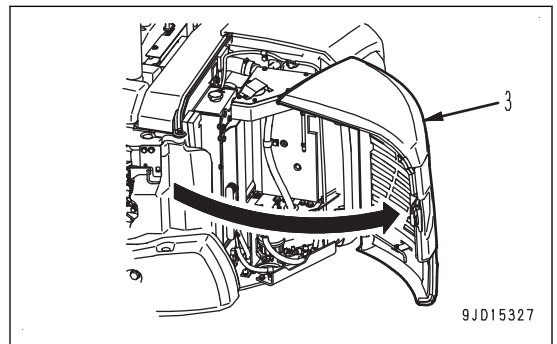

3. Turn the rod (4) to LOCK position (L), and fix the cooling cover (3) with the rod.

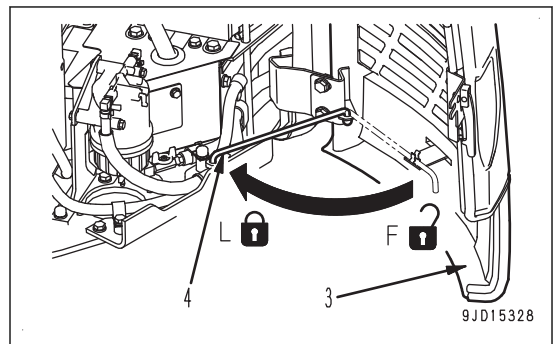

4. Check the front and rear sides of radiator fins (5), oil cooler fins (6), fuel cooler fins (7), and condenser fins (8) (machine equipped with air conditioner). If there is any mud, dirt, leaves, etc. stuck to the fins, blow it off with compressed air.

NOTICE

Steam or water may be used instead of the compressed air. However, when performing powerful steam cleaning (high-pressure machine wash) of the heat exchange equipment (radiator, oil cooler, after-cooler, and fuel cooler), maintain sufficient distance from the machine when performing the work.

If steam cleaning (high-pressure machine wash) is performed at close distance, there is a danger that the internal fins of the heat exchange equipment may be deformed, and this will cause early clogging and breakage of the equipment.

5. Visually check the rubber hose connected to the heat exchange equipment.
If the rubber hose is cracked or become fragile, ask your Komatsu distributor for replacement.
6. Check the hose clamps for looseness.
If the hose clamps are loosened, tighten them.
7. Turn the rod (4) to FREE position (F), and close the cooling cover (3).
8. Close the engine rear cover (1).

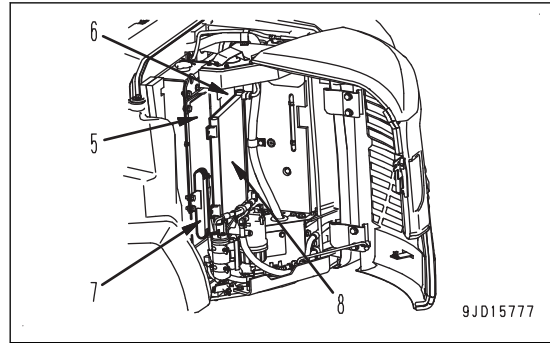

METHOD FOR CLEANING AIR CONDITIONER FRESH AIR FILTER

(Machine with cab specification)

WARNING

When using the compressed air, there is a danger that dirt may scatter and cause personal injury. Wear the protective equipment such as the protective eyeglasses and dust mask.

NOTICE

- As a guideline, the filters should be cleaned every 500 hours, but on dusty jobsites, clean the filters more frequently.
- Before cleaning the fresh air filter, stop the air conditioner.

1. Loosen the knob (1) and remove the filter inspection cover (2).

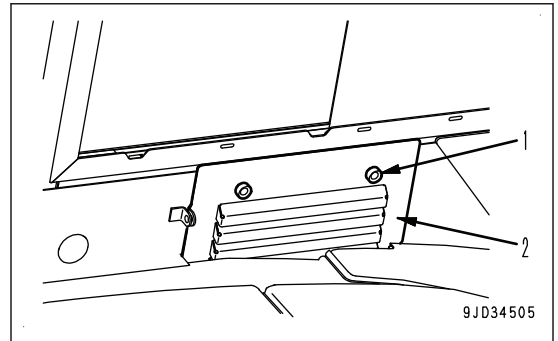

2. Remove the fresh air filter (3).

3. Clean the fresh air filter (3) with compressed air.

- If there is oil on the fresh air filter, or if the filter is extremely dirty, wash it in a neutral detergent. After rinsing it in water, dry it thoroughly before using it again.
- Replace the fresh air filter with a new one every year. If the clogging of the fresh air filter (3) cannot be removed by blowing with compressed air or washing in water, replace the filter immediately.

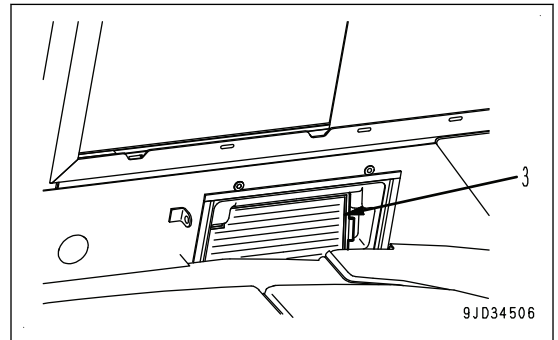

4. Restore the fresh air filter (3).

5. Install the filter inspection cover (2) and tighten the knob (1).

METHOD FOR REPLACING HYDRAULIC TANK BREATHER ELEMENT

WARNING

- Immediately after the engine is stopped, its parts and oil are still very hot and may cause burn injury. Wait for the temperature to go down, and then start the work.
- When removing the oil filler cap, the oil may spurt out. Turn it slowly to release the internal pressure, then remove it carefully.

1. Open the dirt cover (1).
Open the dirt cover (1) fully and it will be secured by the cover support lever (2).

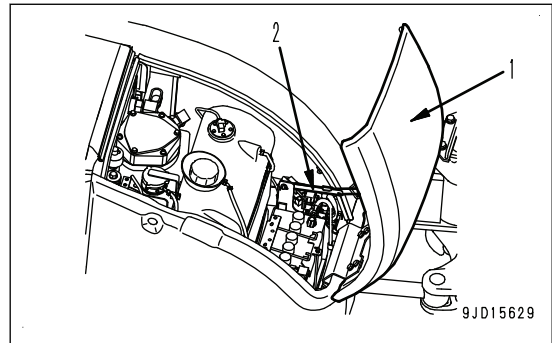

2. Loosen the bolt (3) of the hydraulic tank, move the plate (4) on the oil filler port (F), and turn the cap of the oil filler port (F) slowly to remove it.
Release the internal pressure.

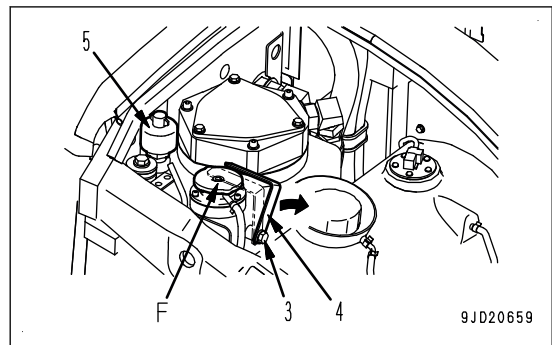

3. Remove the nut (6) of breather (5), and then remove the cover (7).

Use a tool when nut (6) is too tight to remove.

4. Replace the element (8) with a new element.

5. Install the cover (7) and nut (6).

In order not to damage the threaded portion of nut, tighten the nut (6) by hand until it is seated, then retighten it 15 to 30 ° by using a tool.

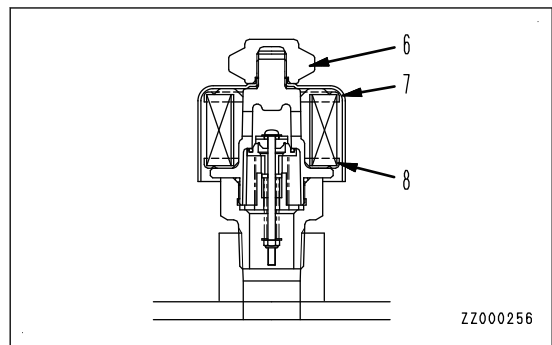

6. Start the engine.

7. Set the lock lever to FREE position (F).

Be sure to operate the lock lever by the operating portion on the top.

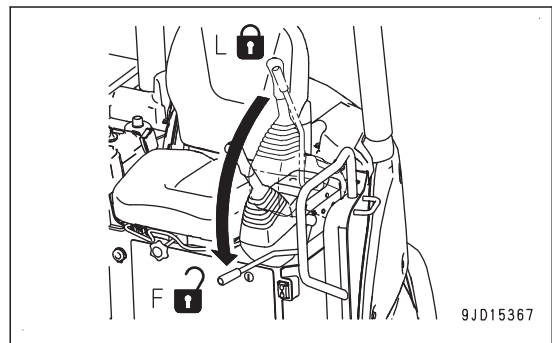

8. Operate the work equipment control levers, and extend the boom cylinder, bucket cylinder, and arm cylinder to their stroke end.

Set the work equipment in the posture shown in the figure.

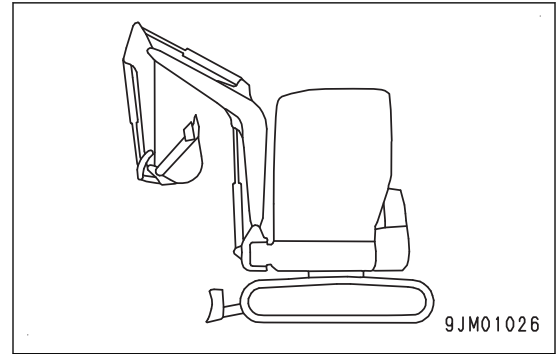

9. Set the lock lever securely to LOCK position (L).
Be sure to operate the lock lever by the operating portion on the top.

10. Stop the engine.

11. Tighten the cap of oil filler port (F) on the hydraulic tank securely.

By doing so, the hydraulic tank is pressurized.

NOTICE

If the hydraulic tank is not pressurized, air is sucked in the pump and it affects the components badly.

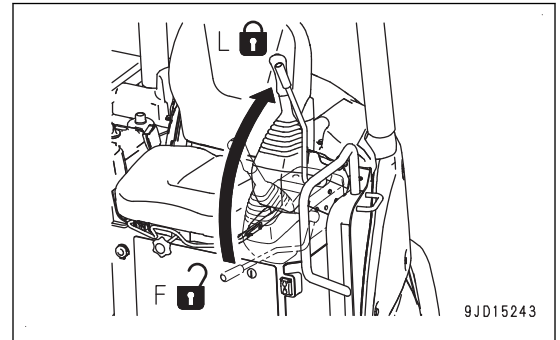

12. Return the plate (4) on the oil filler port (F) of the hydraulic tank to its original position, and fix it with bolt (3).
13. Close the dirt cover (1).

METHOD FOR CHECKING OIL LEVEL IN FINAL DRIVE CASE, ADDING OIL

⚠ WARNING

- Immediately after the engine is stopped, its parts and oil are still very hot and may cause burn injury.
Wait for the temperature to go down, and then start the work.
- If there is remaining pressure inside the case, the oil or plug may jump out.
Loosen the plug slowly to release the pressure.
- Do not stand in front of the plug when you loosen the plug.

Items to be prepared

- Container to catch drained oil
- Hexagonal wrench

1. Bring plug (P) to the lowest position.
2. Place a container under plug (G) to catch the drained oil.
3. Remove plug (G) with the hexagonal wrench.
4. Check the oil level.

The oil level should be near the lower edge of the hole of plug (G).

5. If the oil level is low, remove plug (F) with the hexagonal wrench and add oil.

Add oil until it overflows from the hole of plug (G).

6. After checking, tighten plugs (F) and (G).

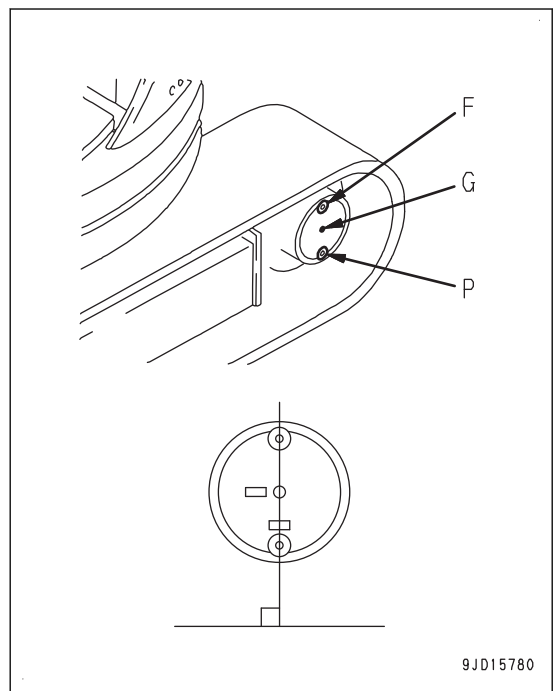

METHOD FOR CHECKING FAN BELT TENSION AND REPLACING FAN BELT

⚠ WARNING

- The opening and closing (tilting) operation of the floor is necessary when performing this maintenance, and it may cause serious personal injury or death. Before opening and closing of the floor, thoroughly read “METHOD FOR OPENING AND CLOSING FLOOR UNIT”, and then start the operation, or ask your Komatsu distributor to perform the work.
- Immediately after the engine is stopped, its parts and oil are still very hot and may cause burn injury. Wait for the temperature to go down, and then start the work.

1. Pull the engine rear cover (1) backward to open it.
Open the engine rear cover (1) fully and it is secured by rod (2).

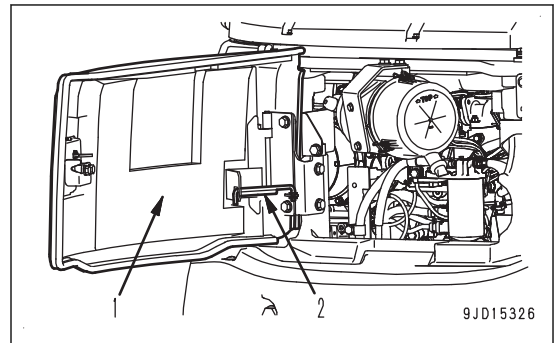

2. Check the fan belt tension.
Press the belt with a finger at a point midway between the crank pulley and fan pulley. (approximately 98 N {approximately 10 kg})
If deflection is in the standard range (9 to 13 mm {0.354 to 0.512 in}), the fan belt tension is correct.

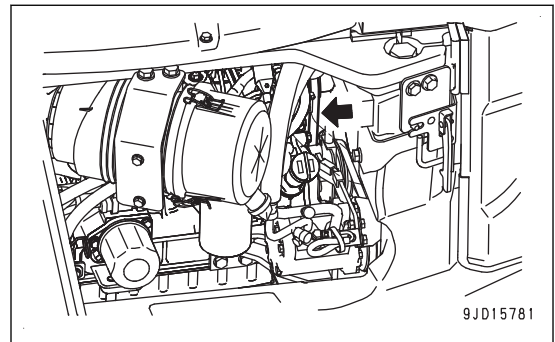

If the deflection is out of the standard range, adjust it into the standard range according to the following procedure.

- 1) Open the floor.
For details, see “METHOD FOR OPENING FLOOR UNIT”.
- 2) Loosen the mounting nut (4) under alternator (3), mounting bolt (6) of belt adjuster (5), and mounting bolt (7) of belt adjuster (5).
- 3) Turn the lock nut (8) for adjuster bolt and adjustment bolt (9) to adjust the position of alternator (3).
Turn the adjustment bolt (9) clockwise to increase the tension.
- 4) Check the fan belt tension again.
If the tension is not correct, adjust it again.
- 5) After the position of alternator (3) is fixed, tighten the mounting nut (4), mounting bolt (6) of belt adjuster (5), and tightening bolt (7) to the belt adjuster (5) to secure the alternator (3).
- 6) Check each pulley for damage, wear of the V-groove, and the wear of the V-belt. In particular, be sure to check that the V-belt is not touching the bottom of the V-groove.

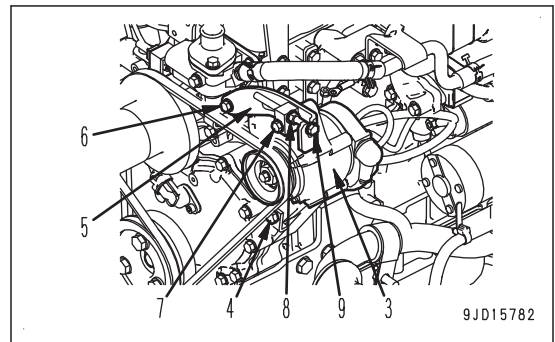

Replace the belt with a new one if the belt is stretched and has no allowance for adjustment, or has slipping sound or squeak because of cuts or cracks.

When replacing the belt with a new one, ask your Komatsu distributor to perform the work.

When the new V-belt is installed, readjust it after operating for 1 hour.

- 7) After the adjustment is completed, close the floor.
For details, see "METHOD FOR CLOSING FLOOR UNIT".
3. Close the engine rear cover (1).

EVERY 1000 HOURS MAINTENANCE

Maintenance for every 100, 250 and 500 hours should be performed at the same time.

METHOD FOR REPLACING HYDRAULIC OIL FILTER ELEMENT

WARNING

- Immediately after the engine is stopped, its parts and oil are still very hot and may cause burn injury. Wait for the temperature to go down, and then start the work.
- When removing the oil filler cap, the oil may spurt out. Turn it slowly to release the internal pressure, then remove it carefully.

NOTICE

If the machine is equipped with a hydraulic breaker, the hydraulic oil deteriorates faster than in the normal bucket digging operation. Accordingly, perform the maintenance by referring to “MAINTENANCE INTERVAL FOR HYDRAULIC BREAKER”.

1. Open the dirt cover (1).
Open the dirt cover (1) fully and it will be secured by the cover support lever (2).

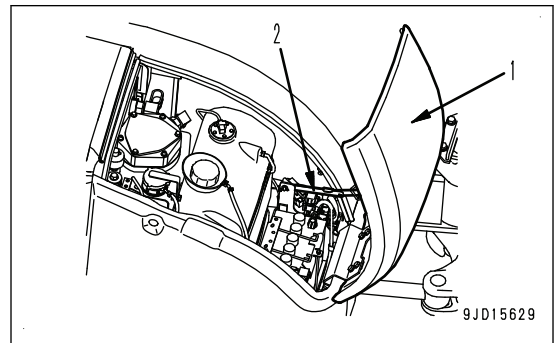

2. Loosen the bolt (3) of the hydraulic tank, move the plate (4) on the oil filler port (F), and turn the cap of the oil filler port (F) slowly to remove it.
Release the internal pressure.

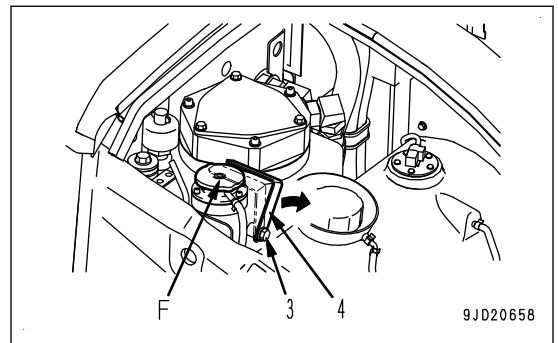

3. Remove the cover mounting bolt (5), and remove the cover (6).
The cover (6) may be jumped out by spring (7).
While pressing down the cover (6), remove the cover mounting bolt (5).
4. After removing the spring (7) and valve (8), take out the element (9).
5. Remove all dirt from the parts taken out, then wash it in clean diesel fuel or flushing oil.
6. Install the new element in the place where the old element (9) has been installed.
7. Check the O-ring (10) to be fit between the hydraulic tank and cover (6).
If the O-ring is damaged, replace it with a new O-ring.
8. Place the valve (8) and spring (7) on top of the element.
9. While pressing the cover (6) by hand, install the cover (6) with the cover mounting bolts (5).
10. Start the engine.
11. Set the lock lever to FREE position (F).
Be sure to operate the lock lever by the operating portion on the top.

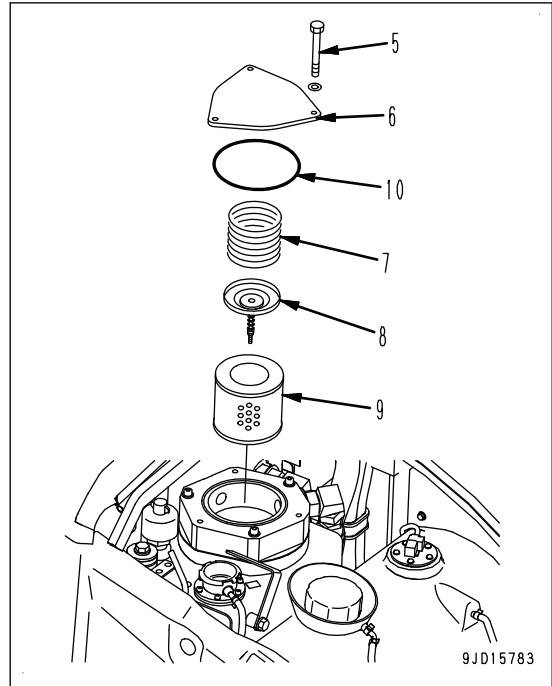

12. Operate the work equipment control levers, and extend the boom cylinder, bucket cylinder, and arm cylinder to their stroke end.

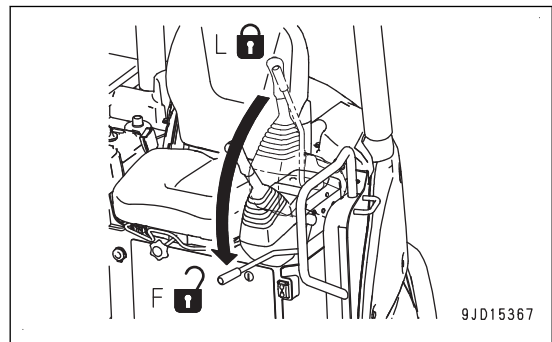

13. Set the lock lever securely to LOCK position (L).
Be sure to operate the lock lever by the operating portion on the top.
14. Stop the engine.
15. Tighten the cap of oil filler port (F) on the hydraulic tank securely.
By doing so, the hydraulic tank is pressurized.

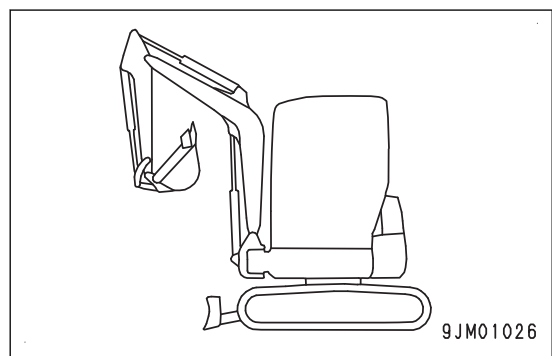

NOTICE

If the hydraulic tank is not pressurized, air is sucked in the pump and it affects the components badly.

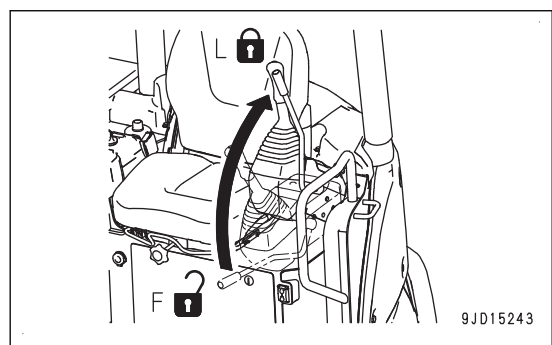

16. Return the plate (4) on the oil filler port (F) of the hydraulic tank to its original position, and fix it with bolt (3).

17. Close the dirt cover (1).

METHOD FOR CHANGING OIL IN FINAL DRIVE CASE

⚠ WARNING

- Immediately after the engine is stopped, its parts and oil are still very hot and may cause burn injury. **Wait for the temperature to go down, and then start the work.**
- If there is remaining pressure inside the case, the oil or plug may jump out. **Loosen the plug slowly to release the pressure.**
- **Do not stand in front of the plug when you loosen the plug.**

Final drive case (each of right and left) refill capacity: 0.7 ℓ {0.18 U.S.Gal}

Items to be prepared

- Container to catch drained oil
 - Hexagonal wrench
1. Bring plug (P) to the lowest position.
 2. Place a container under plug (P) to receive the drained oil.
 3. By using a hexagonal wrench, remove plugs (P), (G), and (F) , and drain the oil.
 4. Tighten plug (P).
 5. Add the refill capacity of oil through plug (F) hole.
 6. When oil begins to overflow from plug (G) hole, install plugs (G) and (F).

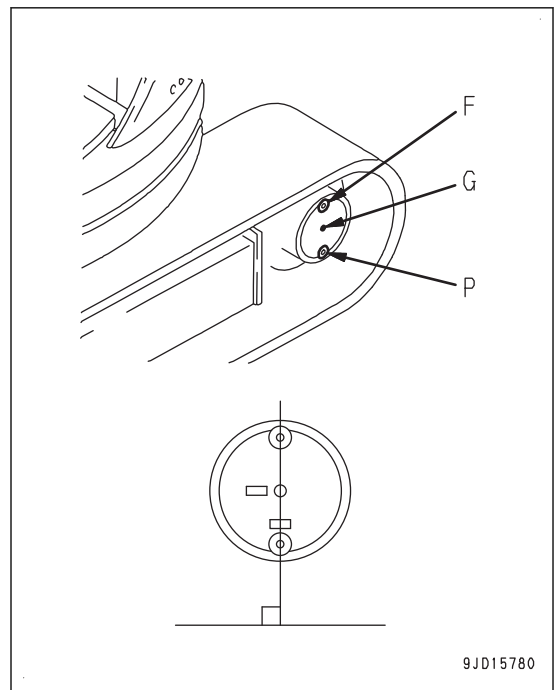

METHOD FOR CHECKING AND ADJUSTING ENGINE VALVE CLEARANCE

Special tools are necessary for inspection and maintenance. Ask your Komatsu distributor to perform this work.

EVERY 1500 HOURS MAINTENANCE

Maintenance for every 100, 250 and 500 hours should be performed at the same time.

METHOD FOR CHECKING CRANKCASE BREATHER

If the crankcase breather does not work normally, the engine does not conform to the exhaust gas regulations under usage period. It is necessary to check the diaphragm for damage and the spring for breakage. Special tools are needed for inspection and maintenance, so ask your Komatsu distributor to perform this work.

EVERY 2000 HOURS MAINTENANCE

Maintenance for every 100, 250, 500 and 1000 hours should be performed at the same time.

METHOD FOR CHANGING OIL IN HYDRAULIC TANK, CLEANING HYDRAULIC TANK STRAINER

WARNING

- Immediately after the engine is stopped, its parts and oil are still very hot and may cause burn injury. Wait for the temperature to go down, and then start the work.
- When removing the oil filler cap, the oil may spurt out. Turn it slowly to release the internal pressure, then remove it carefully.

NOTICE

If the machine is equipped with a hydraulic breaker, the hydraulic oil deteriorates faster than in the normal bucket digging operation. Accordingly, perform the maintenance by referring to “MAINTENANCE INTERVAL FOR HYDRAULIC BREAKER”.

Hydraulic tank refill capacity: 20 ℓ {5.28 U.S.Gal}

Items to be prepared

- Container to catch the drained oil
- Socket wrench handle

1. Set the machine in the posture shown in the figure.
 - 1) Start the engine.

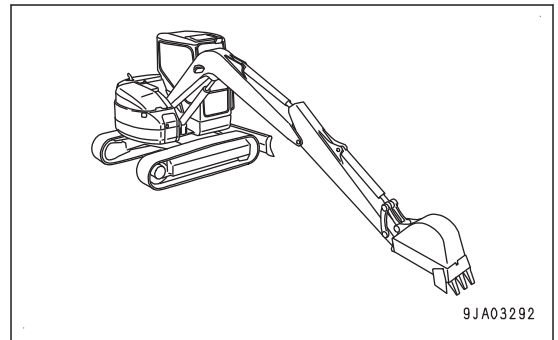

- 2) Set the lock lever to FREE position (F).
Be sure to operate the lock lever by the operating portion on the top.
- 3) Operate the blade control lever to lower the blade to the ground.
- 4) Operate the work equipment control lever to swing the upper structure.
Bring the drain plug at the bottom of the hydraulic tank to the middle between the left and right tracks.

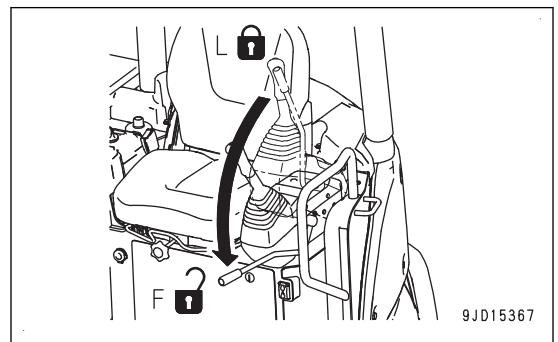

- 5) Operate the work equipment control levers, and retract arm cylinder and bucket cylinder to their stroke end (maximum reach posture of arm and bucket).
- 6) Operate the boom swing control pedal to swing the boom to the center position.
- 7) Operate the work equipment control lever slowly to the boom LOWER direction, and lower the boom and make tooth contact to the ground.

- 8) Set the lock lever to LOCK position (L).
Be sure to operate the lock lever by the operating portion on the top.
- 9) Stop the engine.

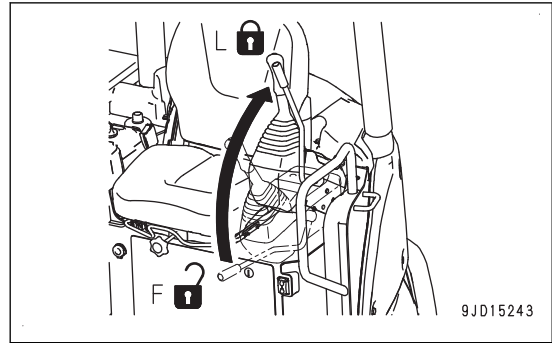

- 2. Open the dirt cover (1).
Open the dirt cover (1) fully and it will be secured by the cover support lever (2).

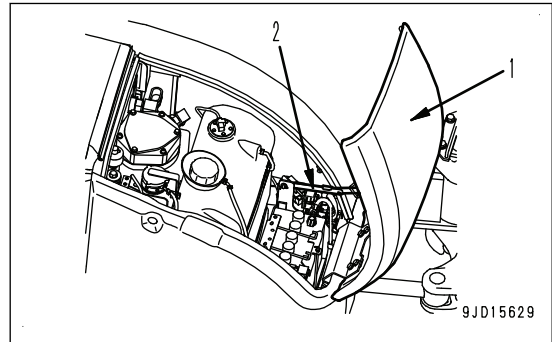

- 3. Loosen the bolt (3) of the hydraulic tank, move the plate (4) on the oil filler port (F), and turn the cap of the oil filler port (F) slowly to remove it.
Release the internal pressure.

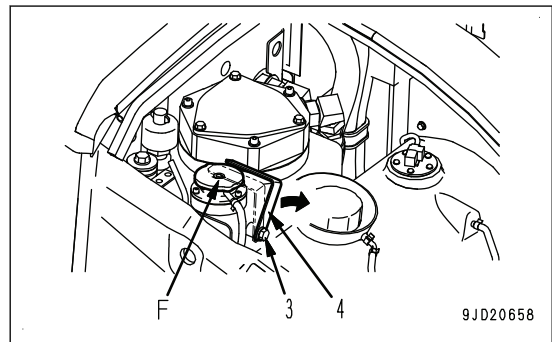

- 4. Place the oil container under the drain plug (P) at the bottom of the machine to catch the drained oil.
- 5. Remove the drain plug (P) to drain the oil by using the socket wrench handle.
When removing the drain plug (P), be careful not to get oil on yourself.
- 6. Check the O-ring installed to the drain plug (P) for damage.
If the O-ring is damaged, replace it with new O-ring.
- 7. After draining the oil, tighten the drain plug (P).

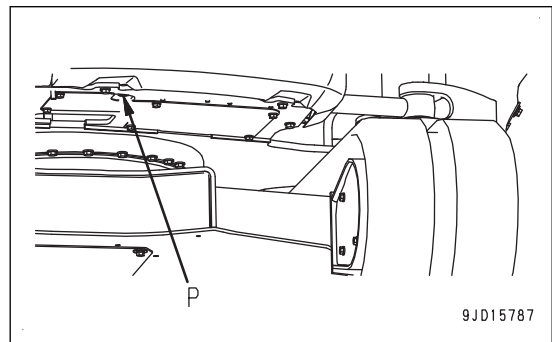

- 8. Loosen the bolts (5) at the bottom of hydraulic tank, and remove the undercover (6).
- Tightening torque:
58.8 to 78.4 Nm {6 to 8 kgm, 43.4 to 57.8 lbft}

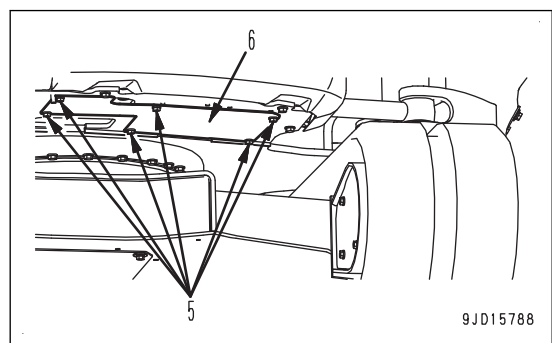

9. Loosen the hose clamp (7) and remove the hose (8).
10. Loosen the bolts (9) and remove the tube (10).
11. Remove the O-ring (11) and strainer (12) from tube (10), remove dirt, etc. stuck to the tube, and then wash it in clean diesel fuel or flushing oil.
Replace the O-ring (11) with a new O-ring.
If strainer (12) is damaged, replace it with a new strainer.
12. Fix the strainer (12) with bolt (9).
13. Install the hose (8) and fix it with hose clamp (7).
14. Install the undercover (6) with bolts (5) to the bottom of the hydraulic tank.
15. Add the refill capacity of oil through the oil filler port (F) of the hydraulic tank.

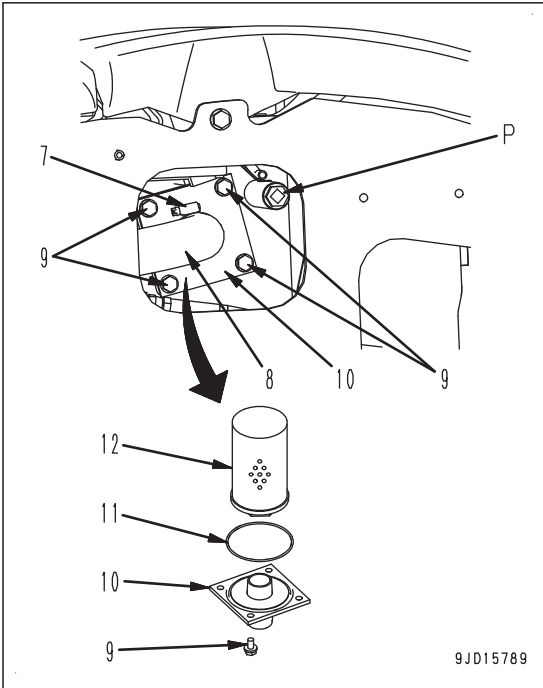

16. Check the oil level through sight gauge (G).

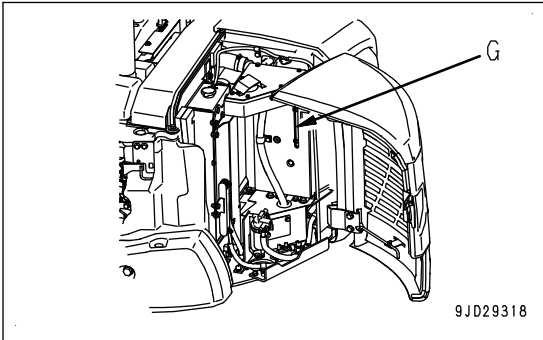

It is appropriate if the oil level is between H and L.

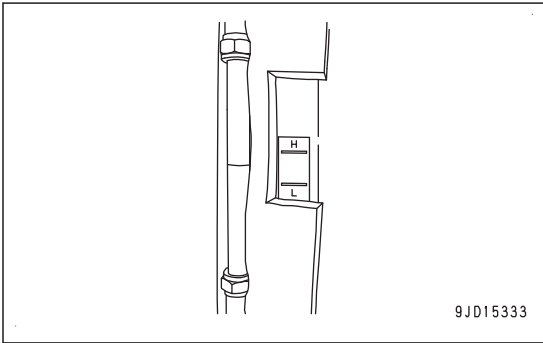

17. Start the engine.
18. Set the lock lever to FREE position (F).
Be sure to operate the lock lever by the operating portion on the top.

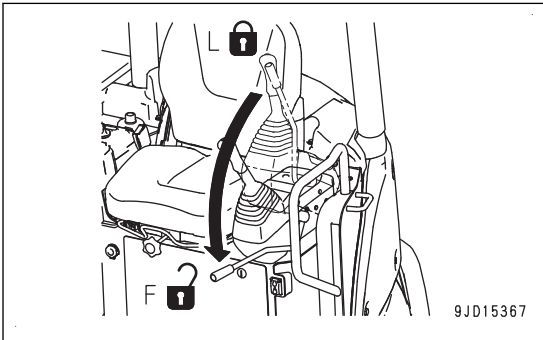

19. Operate the work equipment control levers, and extend the boom cylinder, bucket cylinder, and arm cylinder to their stroke end.

Set the work equipment in the posture shown in the figure.

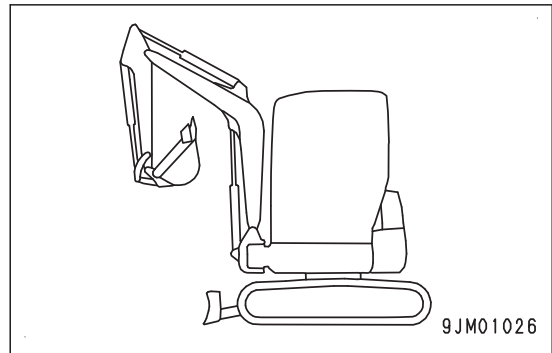

20. Set the lock lever securely to LOCK position (L).
Be sure to operate the lock lever by the operating portion on the top.

21. Stop the engine.

22. Tighten the cap of oil filler port (F) on the hydraulic tank securely.

By doing so, the hydraulic tank is pressurized.

NOTICE

If the hydraulic tank is not pressurized, air is sucked in the pump and it affects the components badly.

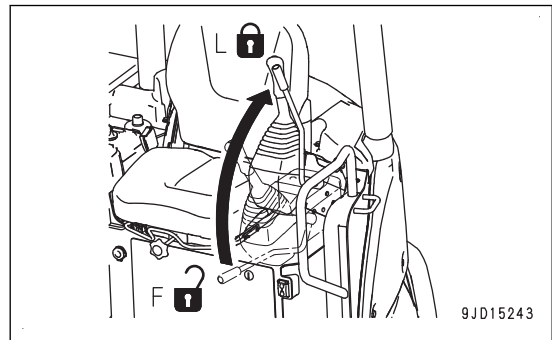

23. Return the plate (4) on the oil filler port (F) of the hydraulic tank to its original position, and fix it with bolt (3).
24. Close the dirt cover (1).

METHOD FOR CHECKING AND RELEASING NITROGEN GAS CHARGE PRESSURE IN ACCUMULATOR (FOR CONTROL CIRCUIT)

WARNING

The accumulator is charged with high-pressure nitrogen gas. Observe the following for handling it, otherwise improper operation may cause an explosion which will lead to serious injury or death.

- The pressure in the hydraulic circuit cannot be completely removed. When removing the hydraulic equipment, do not stand in the direction that the oil spurts out when performing the operation. Loosen the screws slowly when performing the work.
- Do not disassemble.
- Do not bring open flame close to it or do not dispose of it in fire.
- Do not perform drilling, welding or flame-cutting.
- Do not hit or roll it, or subject it to any impact.
- When disposing of it, the gas must be released. Ask your Komatsu distributor to perform this work.

NOTICE

If the nitrogen gas charge pressure in the accumulator is low and operations are continued, it becomes impossible to release the remaining pressure inside the hydraulic circuit if a failure occurs on the machine.

FUNCTION OF ACCUMULATOR

The accumulator has function of storing the pressure of the control circuit in it. Even after the engine is stopped, the control circuit can be operated as long as the accumulator functions normally, so the following actions are possible.

- The work equipment is lowered under its own weight when moving the control lever in the direction to lower the work equipment.
- The pressure in the hydraulic circuit can be released.

REMARK

This function can be used when the starting switch is in ON position and the lock lever is in FREE position.

The accumulator is installed to the position shown in the figure.

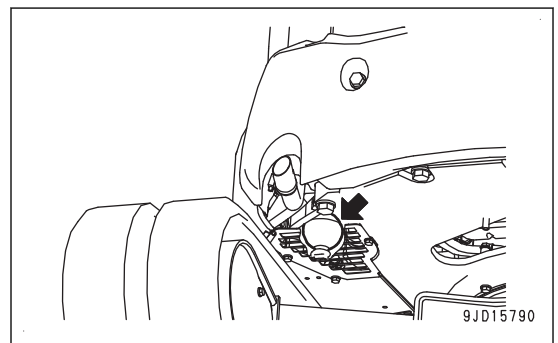

METHOD FOR CHECKING FUNCTION OF ACCUMULATOR

⚠ CAUTION

Be sure that no person or obstacle is around the machine before performing the inspection.

1. Start the engine.
2. Set the lock lever to FREE position (F).
Be sure to operate the lock lever by the operating portion on the top.
3. Place the machine on a firm, level ground.

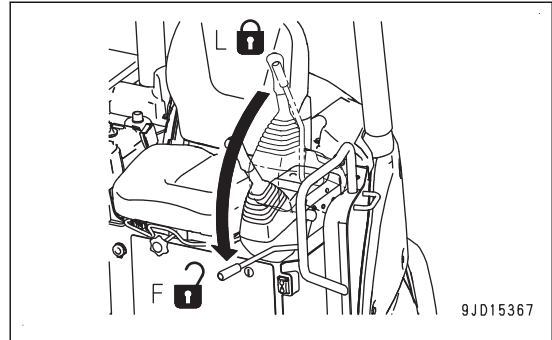

4. Set the work equipment to the posture shown in the figure according to the following procedure.
 - 1) Operate the work equipment control levers, and retract arm cylinder and bucket cylinder to their stroke end (maximum reach posture of arm and bucket).
 - 2) Operate the boom swing control pedal to swing the boom to the center position.
 - 3) Operate the work equipment control lever, and raise the work equipment to height (a) of 1.5 m and hold there.

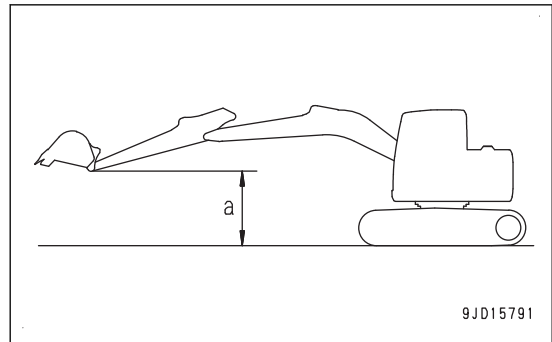

5. Set the lock lever to LOCK position (L).
Be sure to operate the lock lever by the operating portion on the top.

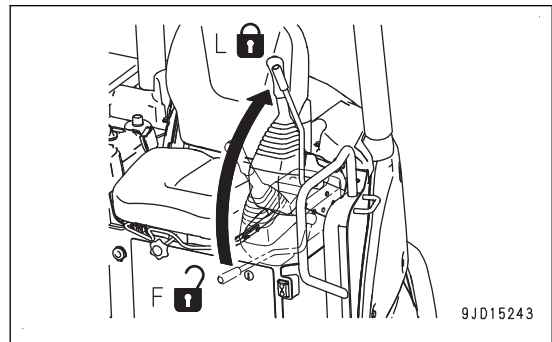

6. Check the nitrogen gas charge pressure in accumulator within 15 seconds according to the following procedure.

When the engine is stopped, the pressure inside the accumulator gradually goes down, so this inspection can be performed only immediately after the engine is stopped.

- 1) Turn the starting switch to OFF position (A) to stop the engine.
Hold the work equipment in the maximum reach posture (arm fully out, bucket fully dumped).

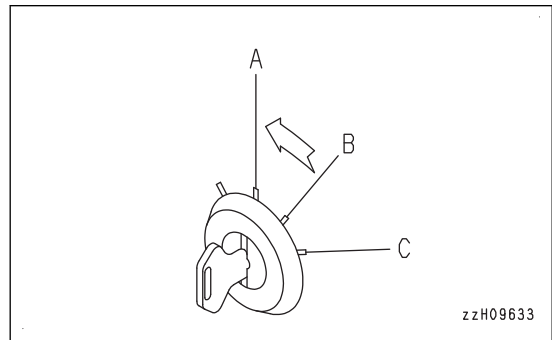

- 2) Turn the starting switch to ON position (B).

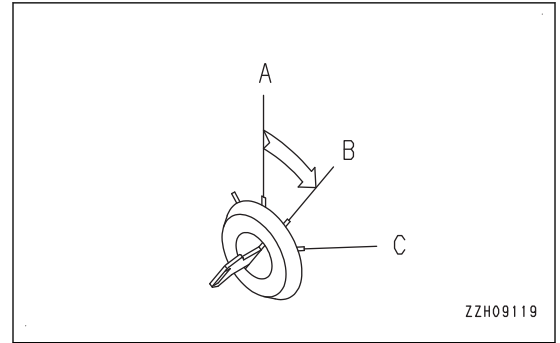

- 3) Set the lock lever to FREE position (F).
Be sure to operate the lock lever by the operating portion on the top.

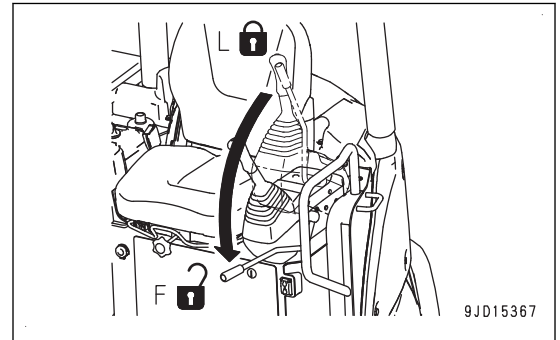

- 4) Operate the work equipment control lever slowly to the boom LOWER direction, and lower the boom and make tooth contact to the ground.

Checking of nitrogen gas charge pressure in accumulator is completed.

- If the work equipment goes down under its own weight and the teeth contact the ground, the accumulator is normal.
- If the work equipment does not go down or stops at halfway, ask your Komatsu distributor for inspection. Nitrogen gas charge pressure in accumulator for control circuit may be decreased.

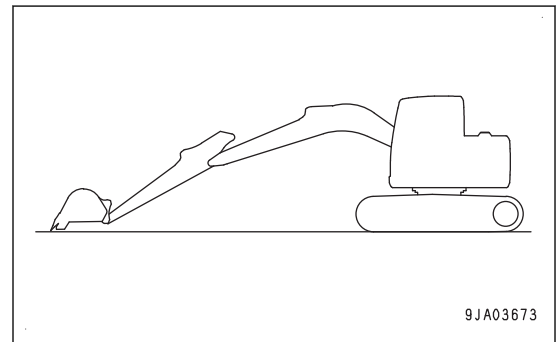

7. After checking the nitrogen gas charge pressure in accumulator, set the lock lever to LOCK position (L).

Be sure to operate the lock lever by the operating portion on the top.

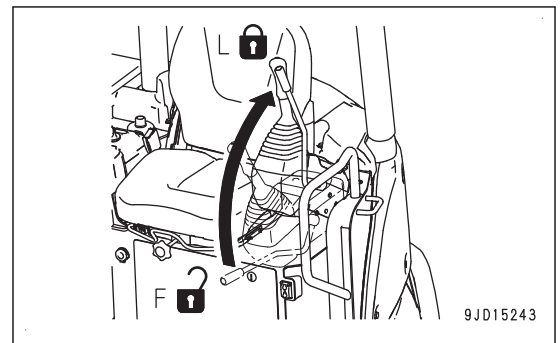

8. Turn the starting switch to OFF position (A).

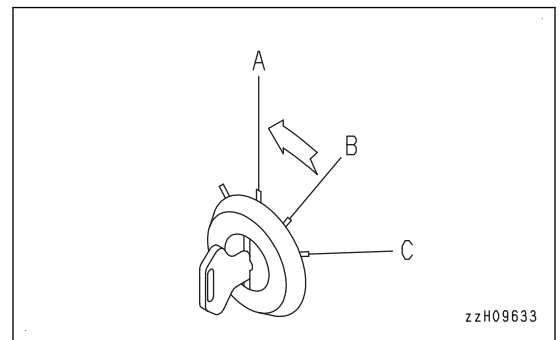

METHOD FOR RELEASING PRESSURE IN HYDRAULIC CIRCUIT

- 1. Start the engine.
- 2. Set the lock lever to FREE position (F).
Be sure to operate the lock lever by the operating portion on the top.
- 3. Place the machine on a firm, level ground.

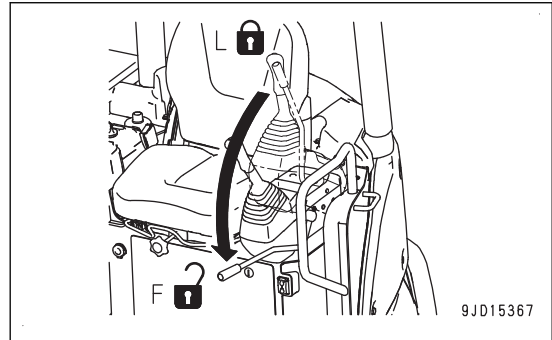

- 4. Set the work equipment to the posture shown in the figure according to the following procedure.
 - 1) Operate the work equipment control levers, and retract arm cylinder and bucket cylinder to their stroke end (maximum reach posture of arm and bucket).
 - 2) Operate the boom swing control pedal to swing the boom to the center position.
 - 3) Operate the work equipment control lever slowly to the boom LOWER direction, and lower the boom and make tooth contact to the ground.

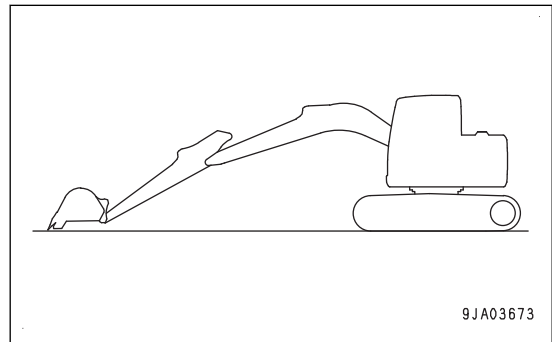

For the attachment such as crusher, etc., keep the attachment in closed state.

- 5. Set the lock lever to LOCK position (L).
Be sure to operate the lock lever by the operating portion on the top.

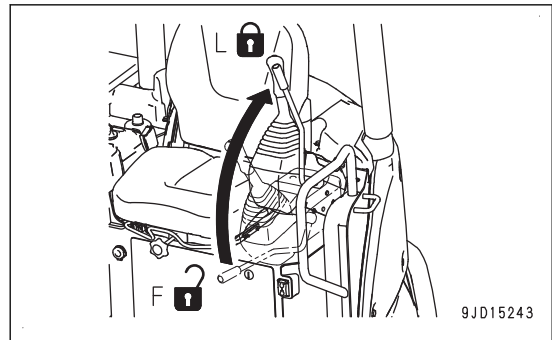

- 6. Release the internal pressure in the hydraulic circuit within 15 seconds according to the following procedure.

When the engine is stopped, the pressure inside the accumulator gradually goes down, so releasing the internal pressure can be performed only immediately after the engine is stopped.

- 1) Turn the starting switch to OFF position (A) to stop the engine.

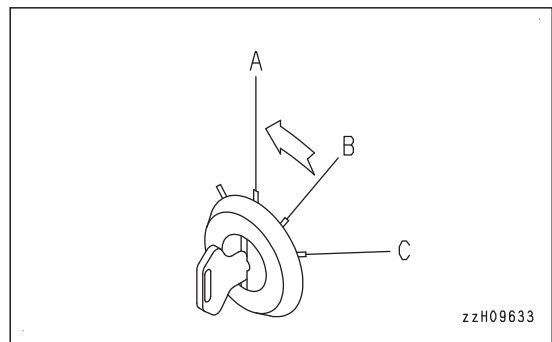

- 2) Turn the starting switch to ON position (B).

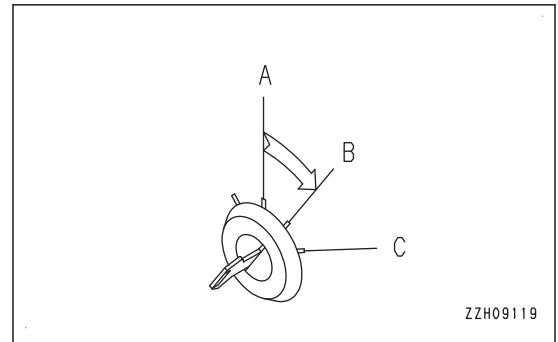

- 3) Set the lock lever to FREE position (F).
Be sure to operate the lock lever by the operating portion on the top.
- 4) Operate the work equipment control levers and attachment control switches in full stroke to the front, rear, right and left.

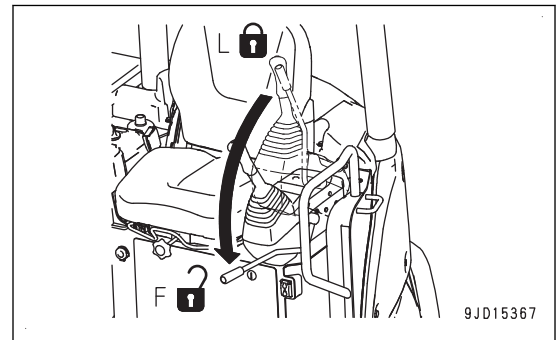

Releasing the internal pressure in the hydraulic circuit is completed.

7. After completion of releasing internal pressure in the hydraulic circuit, set the lock lever to LOCK position (L).
Be sure to operate the lock lever by the operating portion on the top.
If the machine is equipped with the attachment control pedal, set the attachment lock cover to LOCK position.

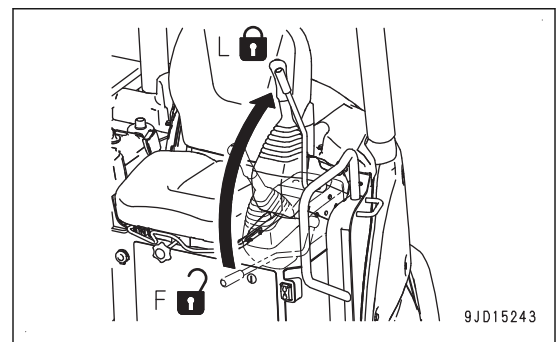

8. Turn the starting switch to OFF position (A).

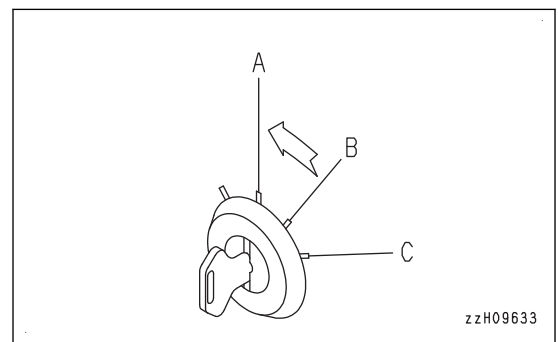

METHOD FOR CHECKING ALTERNATOR AND STARTING MOTOR

The brushes may be worn or the bearing may have run out of grease, contact your Komatsu distributor for inspection and repairs.

If the engine is started frequently, have this inspection performed every 1000 hours.

EVERY 3000 HOURS MAINTENANCE

Maintenance for every 100, 250, 500, 1000 and 1500 hours should be performed at the same time.

METHOD FOR CHECKING AND CLEANING FUEL INJECTION SYSTEM

If the fuel injection system does not operate normally, engine performance cannot be obtained thoroughly. It is necessary to check and clean the fuel injection system. Special tools are needed for inspection and maintenance, so ask your Komatsu distributor to perform this work.

EVERY 4000 HOURS MAINTENANCE

Maintenance for every 100, 250, 500, 1000 and 2000 hours should be performed at the same time.

REPLACE DEFINED LIFE PARTS

Material quality of these parts can change as time passes and they are likely to wear out or deteriorate.

Replace them every 2 years or every 4000 hours, whichever comes sooner.

DEFINED LIFE PARTS LIST

No.	Periodical replacement parts		
1	Fuel system	Fuel hose Spill hose	Ask your Komatsu distributor for replacement.
2	Engine lubrication system	Engine oil filter hose	
3	Work equipment hydraulic system	Main pump delivery hose Pump delivery hose	
		Pump branch hose Main pump LS hose	
		External work equipment hose <ul style="list-style-type: none"> • Boom foot connection hose • Boom cylinder hose • Arm connection hose • Line hose for additional attachment 	
4	Others	PPC accumulator	

METHOD FOR REPLACING ACCUMULATOR (FOR CONTROL CIRCUIT)**⚠ WARNING**

The accumulator is charged with high-pressure nitrogen gas. Observe the following for handling it, otherwise improper operation may cause an explosion which will lead to serious injury or death.

- The pressure in the hydraulic circuit cannot be completely removed. When removing the hydraulic equipment, do not stand in the direction that the oil spurts out when performing the operation. In addition, loosen the bolts slowly when performing the work.
- Do not disassemble.
- Do not bring open flame close to it or do not dispose of it in fire.
- Do not perform drilling, welding or flame-cutting.
- Do not hit or roll it, or subject it to any impact.
- When disposing of it, the gas must be released. Ask your Komatsu distributor to perform this work.

NOTICE

If the nitrogen gas charge pressure in the accumulator is low and operations are continued, it becomes impossible to release the remaining pressure inside the hydraulic circuit if a failure occurs on the machine.

Replace the accumulator every 2 years or every 4000 hours, whichever comes sooner. Ask your Komatsu distributor to replace it.

The accumulator is installed to the position shown in the figure.

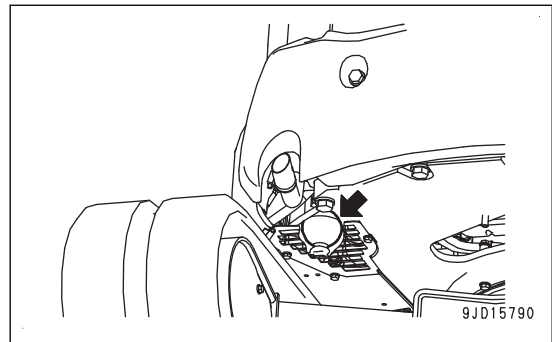

EVERY 6000 HOURS MAINTENANCE

Maintenance for every 100, 250, 500, 1000, 1500, 2000 and 3000 hours should be performed at the same time.

METHOD FOR CLEANING KDPF

Ask your Komatsu distributor for cleaning the inside of KDPF.

SPECIFICATIONS

SPECIFICATIONS

SPECIFICATIONS: PC45MR-5

Item	Unit	PC45MR-5	
		Machine with canopy specification	Machine with cab specification
Operating weight	kg { lb }	4870 {10739}	4990 {11003}
Bucket capacity	m ³ { cu.yd }	0.14 {0.18}	
Engine model	-	Komatsu 4D88E-7 diesel engine	
Rated horsepower	kW { HP } / min ⁻¹ { rpm }	29.1 {39.0} /2400 {2400}	29.1 {39.0} /2400 {2400}
		28.3 {38.0} /2400 {2400}	27.7 {37.7} /2400 {2400}
A Overall length	mm {ft in}	5330 {17' 6"}	
B Overall height	mm {ft in}	2550 {8' 4"}	2590 {8' 6"}
C Overall width	mm {ft in}	1960 {6' 5"}	
D Track width	mm {ft in}	400 {1' 4"}	
E Tail swing radius	mm {ft in}	1040 {3' 5"}	
F Overall length of track	mm {ft in}	2520 {8' 3"}	
G Distance between tumbler centers	mm {ft in}	2000 {6' 7"}	
Minimum ground clearance	mm {ft in}	290 {0' 11"}	
Travel speed (Lo/Hi)	km/h { MPH }	2.6 /4.6 {1.6 /2.9}	
		2.4 /4.3 {1.5 /2.7}	
Continuous swing speed	rpm	9.0	

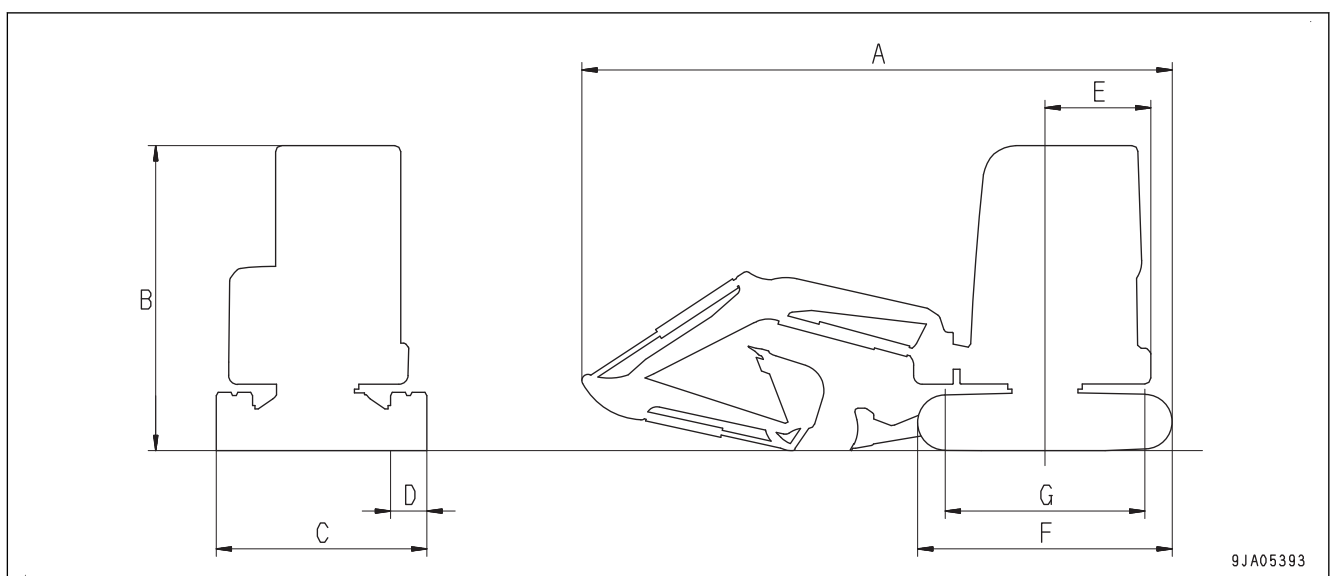

9JA05393

SPECIFICATIONS: PC55MR-5

Item	Unit	PC55MR-5	
		Machine with canopy specification	Machine with cab specification
Operating weight	kg { lb }	5150 {11356}	5270 {11621}
Bucket capacity	m ³ { cu.yd }	0.16 {0.21}	
Engine model	-	Komatsu 4D88E-7 diesel engine	
Rated horsepower	kW { HP } / min ⁻¹ { rpm }	29.1 {39.0} /2400 {2400}	29.1 {39.0} /2400 {2400}
<ul style="list-style-type: none"> SAE J1995 (Gross) ISO 9249/ SAE J1349 (Net) 		28.3 {38.0} /2400 {2400}	27.7 {37.7} /2400 {2400}
A Overall length	mm {ft in}	5550 {18' 3"}	
B Overall height	mm {ft in}	2550 {8' 4"}	2590 {8' 6"}
C Overall width	mm {ft in}	1960 {6' 5"}	
D Track width	mm {ft in}	400 {1' 4"}	
E Tail swing radius	mm {ft in}	1120 {3' 8"}	
F Overall length of track	mm {ft in}	2520 {8' 3"}	
G Distance between tumbler centers	mm {ft in}	2000 {6' 7"}	
Minimum ground clearance	mm {ft in}	290 {0' 11"}	
Travel speed (Lo/Hi)	km/h { MPH }	2.6 /4.6 {1.6 /2.9}	
<ul style="list-style-type: none"> For the machine equipped with rubber shoe For the machine equipped with steel shoe and road liner 		2.4 /4.3 {1.5 /2.7}	
Continuous swing speed	rpm	9.0	

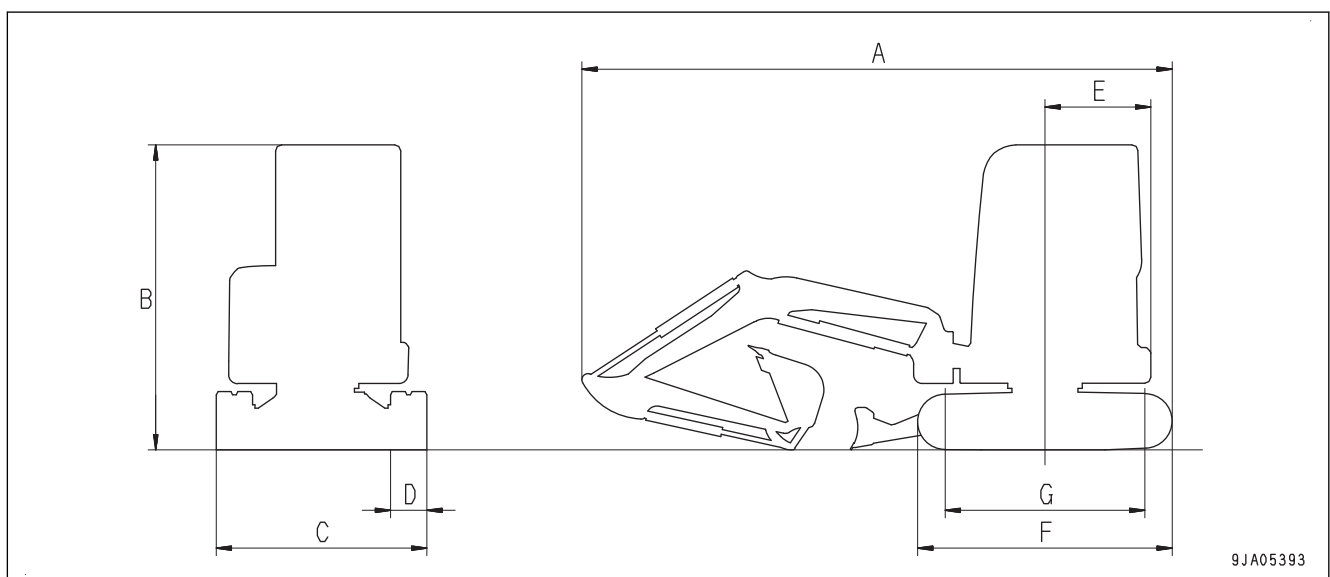

ATTACHMENTS AND OP- TIONS

WARNING

Please read and make sure that you understand the SAFETY section before reading this section.

PRECAUTIONS FOR USING ATTACHMENT AND OPTIONS

WARNING

Install only attachments or options authorized by Komatsu. Komatsu cannot accept any responsibility for any not authorized by Komatsu. Any personal injury, failure, or property damage caused by the use of unauthorized attachments or options will not be the responsibility of Komatsu.

When installing attachments or options to the machine, it is necessary to pay attention to safety. Observe the following precautions strictly when selecting, installing or removing, or using attachments or options.

PRECAUTIONS WHEN SELECTING

Consult your Komatsu distributor before installing attachments or options to the machine. Depending on the type of attachment or option, it may be necessary to install a front guard, overhead guard, or other safety structure to the machine. There may also be problems of the attachment or option hitting the operator's cab.

READ THE OPERATION AND MAINTENANCE MANUAL THOROUGHLY

Before installing or using any attachment or option, make sure that you thoroughly read and understand the instruction manuals for the machine and the attachment or option.

If you lose the instruction manual or it is damaged, obtain a new copy from the attachment manufacturer or your Komatsu distributor.

PRECAUTIONS WHEN REMOVING AND INSTALLING

When removing or installing the attachment or option, observe the following precautions, and take care to ensure safety during the operation.

- Perform the removal and installation operation on a level and firm ground surface.
- When the operation is performed by 2 or more workers, choose the leader and follow his/her instructions.
- Use a crane when handling heavy objects (25 kg or more {55.1 lb or more}).
(The crane must be operated by a qualified operator.)
- Never go under a load raised by the crane.
- Do not perform operations with the load kept raised by the crane. Always use a stand to prevent the load from falling.
- When removing a heavy part, consider the machine balance after it is removed. To prevent the machine from tipping over, set a support in position if necessary before removing the part.
- Before installing or after removing the attachment or option, set it in a stable condition to prevent it from falling over.
- For details of the removal or installation operation, consult your Komatsu distributor.

PRECAUTIONS FOR USING

Keep the following precautions in your mind when long or heavy work equipment is installed. Before starting operations, move the machine to a safe place and perform a test operation to make sure that you fully understand the movement, center of gravity, and working range of the machine.

- Do not perform the swing operation if the machine is at an angle. If the swing is performed with the machine at an angle, there is a danger that the machine may tip over.
- Always allow extra space to the position you want to stop swinging when performing the swing. If long work equipment is installed, the working range becomes larger. So be more careful to maintain a safe distance from the surroundings.
- If heavy work equipment is installed, pay attention to the following precautions.
 - The swing overrun (the distance the work equipment moves before completely stopping after the swing brake is applied) will be greater. It is dangerous if a lifted load hits any person or structure. Always maintain a safe distance to the swing stop position when operating.
 - The hydraulic drift of the work equipment (the amount of the work equipment moves down under its own weight when it is stopped in a raised position) also becomes greater. Do not stop the work equipment in air.
 - Do not suddenly swing, lower, or stop the work equipment. It is dangerous that the machine may tip over.
 - Do not suddenly extend or retract the boom cylinder rod. The shocks may cause the machine to tip over.

HANDLE BUCKET WITH HOOK

When using the bucket with hook, check that there is no damage to the hook, stopper, or hook mount. If there is any problem, ask your Komatsu distributor.

PRECAUTIONS FOR OPERATION

PRECAUTIONS FOR LIFTING OPERATION

- If lifted load largely swings, it is dangerous. Lower the engine speed and operate the work equipment control lever slowly.
- The swing speed of this machine is 3 to 4 times the speed of a mobile crane. Be careful to check that the area around the machine is safe when performing the swing operation.
- Depending on the posture of the work equipment, there is a danger that the wire or load may slip off the hook. Always be careful to maintain the correct hook angle to prevent the slipping-off.
- Never drive the machine while lifting a load.
- If the bucket with hook is turned 180° and used for operations, it will interfere with the arm during the bucket DUMP operation. Be careful when using it.
- During sling work, do not swing the boom or offset it. Align the direction of the boom to the center.
- If you are planning to newly install a hook, ask your Komatsu distributor for installation.

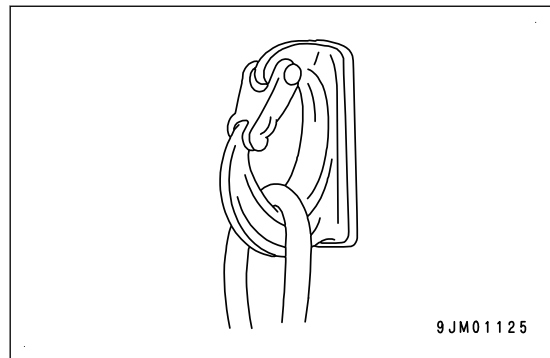
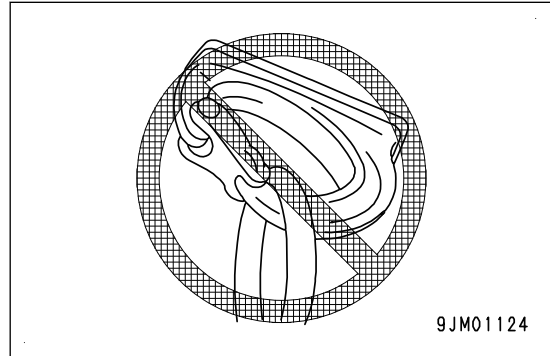

HANDLE MACHINE READY FOR INSTALLATION OF ATTACHMENT

EXPLANATION OF COMPONENTS ON MACHINES WITH ATTACHMENT

EXPLANATION OF COMPONENTS ON MACHINES WITH ATTACHMENT CONTROL PEDAL

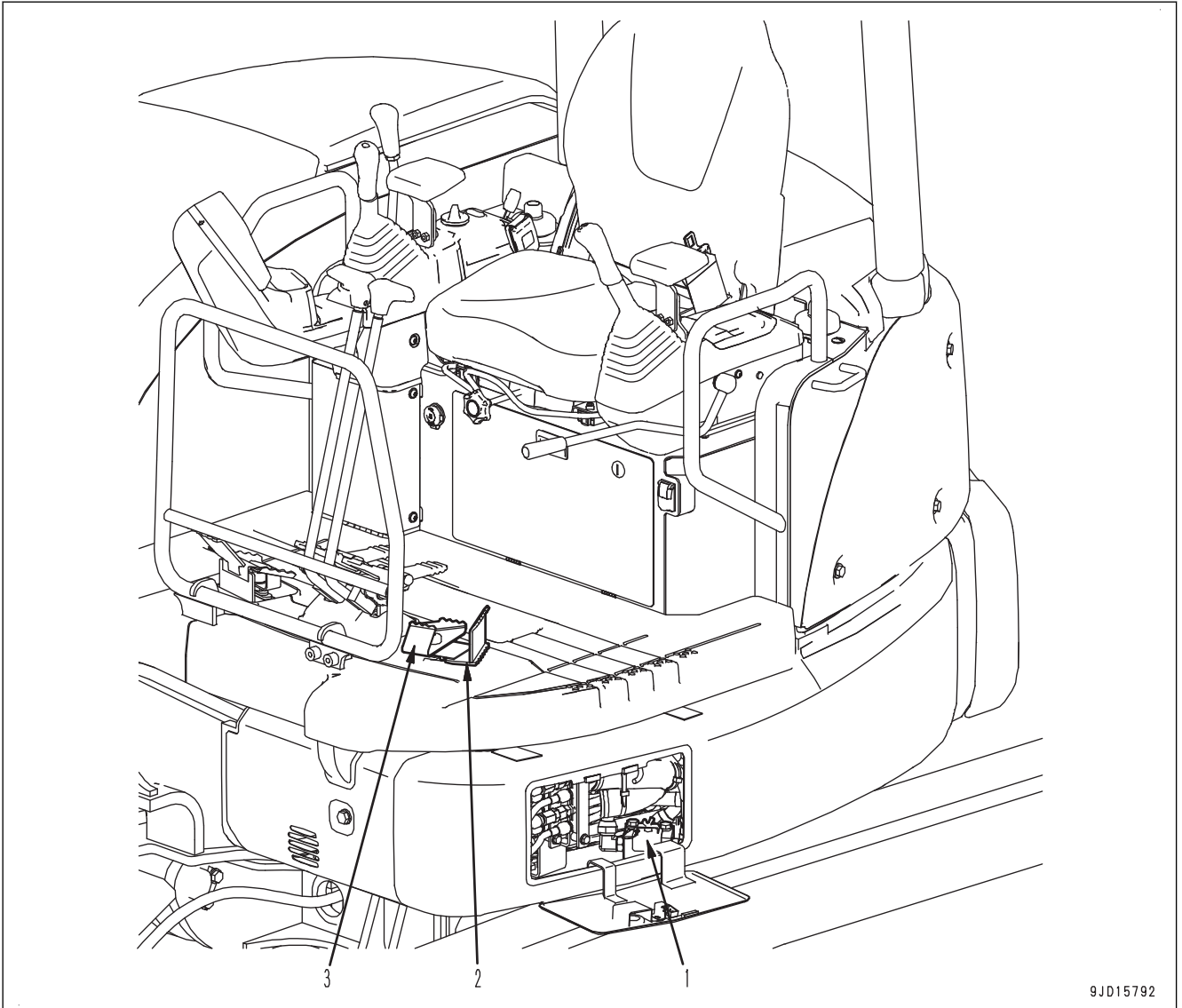

(1) Selector valve

(2) Attachment lock cover

(3) Attachment control pedal

9J015792

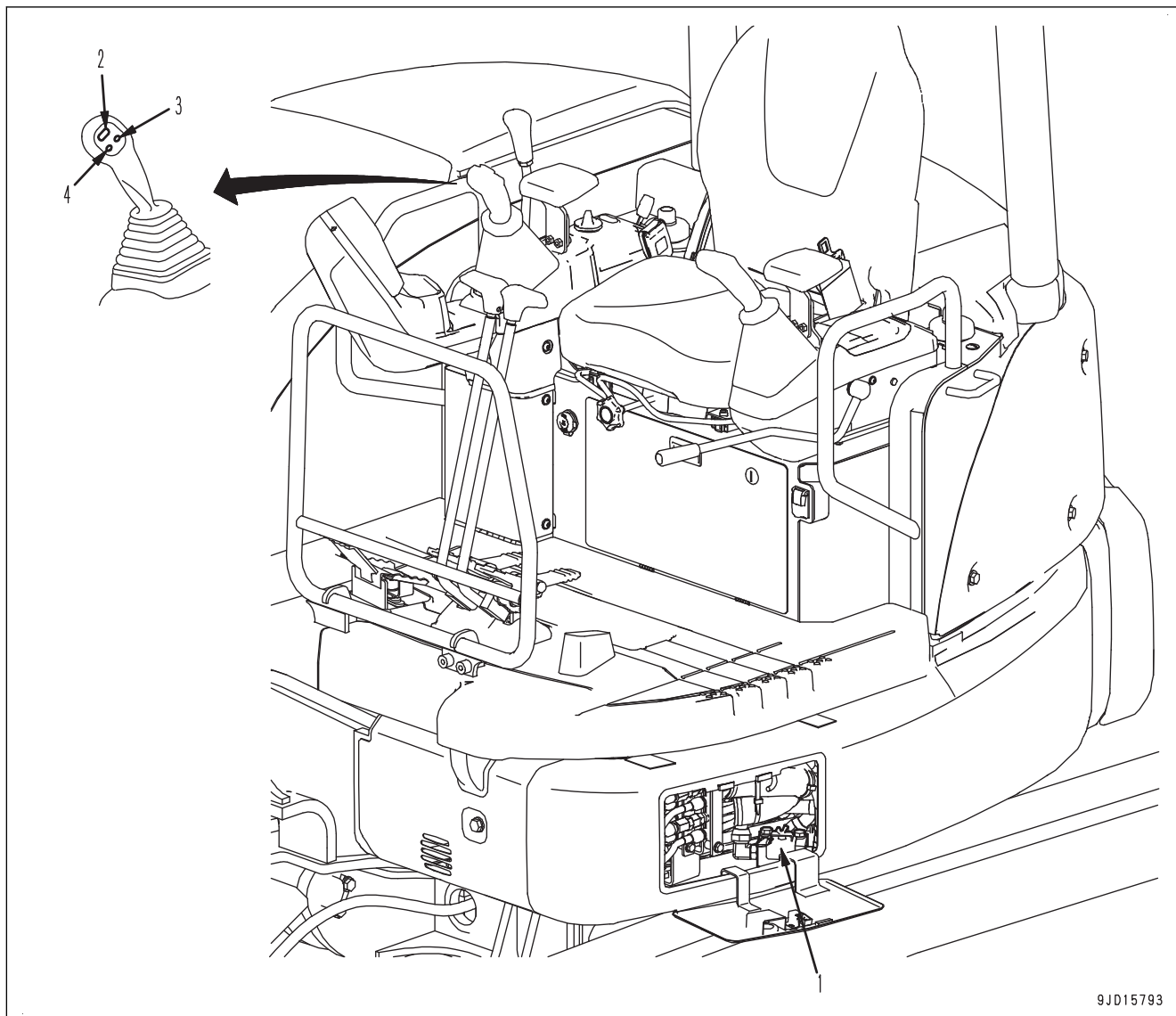
EXPLANATION OF COMPONENTS ON MACHINES WITH PROPORTIONAL LEVER

9JD15793

(1) Selector valve

(2) 1st-line attachment proportional switch

(3) Breaker operation switch

(4) Horn switch

SELECTOR VALVE

The selector valve switches the flow of the hydraulic oil.

Position (a)

When general attachments such as crusher are used

Position (b)

When using the breaker

Width across flats of the square part of spool (1) is 9 mm {0.354 in}.

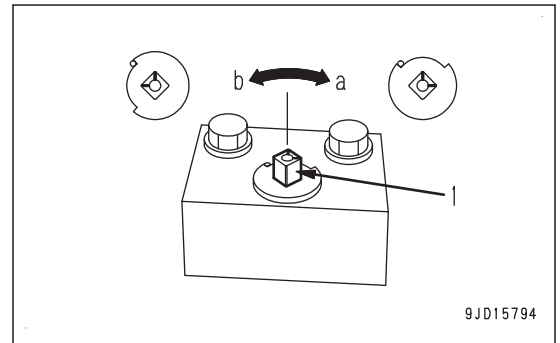

9JD15794

ATTACHMENT CONTROL PEDAL

(For the machine equipped with attachment control pedal)

Attachment control pedal is operated when using the attachment.

Depress upper part

Oil flows to the piping on the right side of the arm (hydraulic tank side).

Depress lower part

Oil flows to the piping on the left side of the arm (operator's seat side).

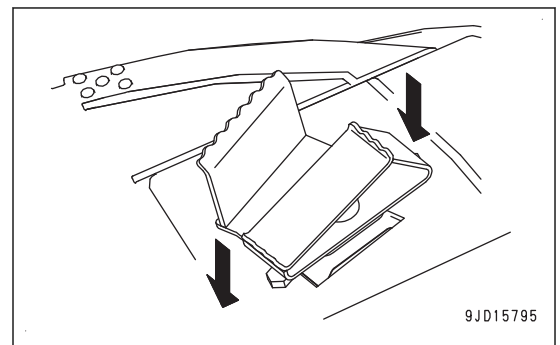

9JD15795

ATTACHMENT LOCK COVER

(For the machine equipped with attachment control pedal)

⚠ WARNING

When the attachment is not used, set the attachment lock cover to LOCK position to prevent the attachment control pedal from moving.

When it is not locked, if you depress the attachment control pedal by mistake, the attachment may suddenly move, and this may lead to serious personal injury or death.

The attachment lock cover locks the attachment control pedal.

When you put the attachment lock cover on the attachment control pedal, it is LOCK position (L).

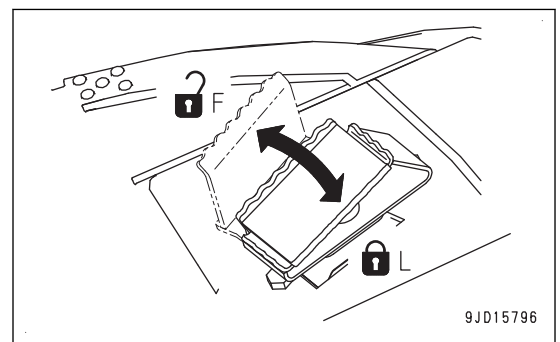

9JD15796

ATTACHMENT 1 PROPORTIONAL SWITCH

(For the machine equipped with proportional lever)

Use the 1st-line attachment proportional switch when operating general attachments such as crusher, etc.

Flow rate can be adjusted according to the operating amount of 1st-line attachment proportional switch.

This switch does not operate unless the working mode selector switch is set to attachment mode.

Push it to the right.

Oil flows to the piping on the right side of the arm (hydraulic tank side).

Push it to the left.

Oil flows to the piping on the left side of the arm (operator's seat side).

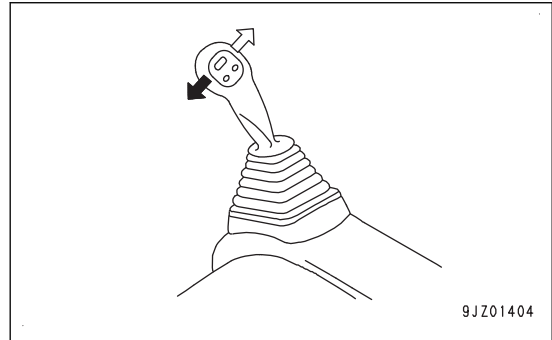

BREAKER OPERATION SWITCH

(For the machine equipped with proportional lever)

The breaker operation switch is used to operate the breaker.

Press the breaker operation switch and the oil flows continuously to the piping at the left side of arm (operator's seat side), and the breaker operates.

Press the breaker operation switch once more and the breaker stops.

This switch does not operate unless the working mode selector switch is set to attachment mode.

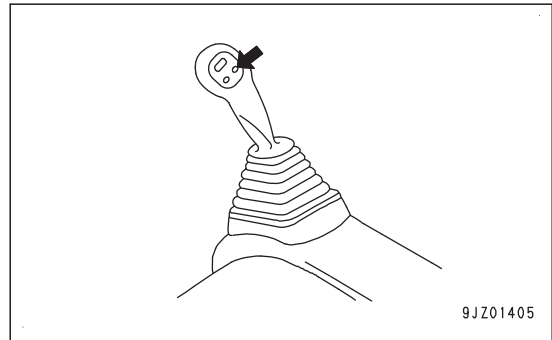

HORN SWITCH

(For the machine equipped with proportional lever)

The horn switch is used to sound the horn.

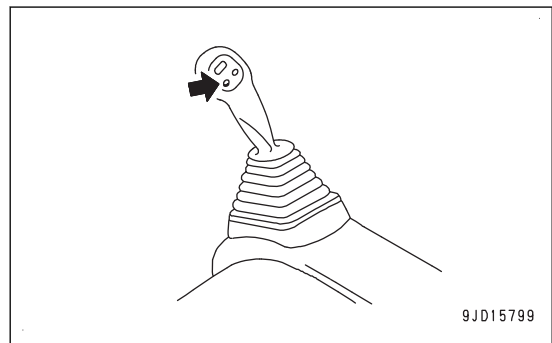

METHOD FOR CHANGING OVER AND CONNECTING HYDRAULIC CIRCUIT OF MACHINES READY FOR INSTALLATION OF ATTACHMENT

METHOD FOR CONNECTING HYDRAULIC CIRCUIT OF MACHINES READY FOR INSTALLATION OF ATTACHMENT

NOTICE

Since the pressure of attachment hydraulic circuit of this machine is set to 17.2 MPa {175 kg/cm², 2490 PSI}, check the withstand pressure of installed attachment.

When arranging the piping, take care that the bucket does not interfere with link (a) even if it is moved to the dump side fully.

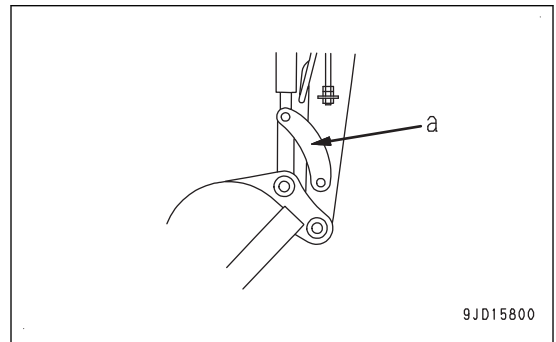

Connect the hydraulic circuit according to the following procedures when installing the attachment.

1. For the machine equipped with attachment control pedal, set the attachment lock cover to LOCK position (L).

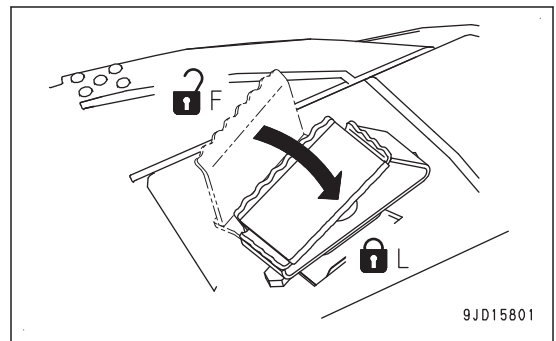

2. Remove the plug.
Be careful not to lose or damage the removed parts.
3. Connect the attachment piping provided by the attachment manufacturer.

Joint screw size is as follows.

Left side of arm

1/2" G

Right side of arm

3/4" G

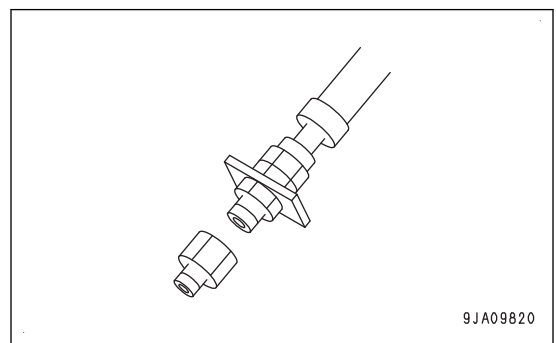

4. Change over the hydraulic circuit corresponding to the attachment installed.
5. After connecting the piping, bleed air from the hydraulic circuit according to the following procedure.

NOTICE

- If the attachment has its own air bleeding procedure specified by the manufacturer, observe them.
- If the engine is run at high speed or a cylinder is pushed up to its stroke end immediately after startup, air taken inside the cylinder may cause damage to the piston packing.

- 1) Start the engine.

Run the engine at low idle for 10 minutes after starting, and then start the following work.

- 2) Operate the work equipment control lever repeatedly to bleed the air completely from the cylinders.

Operate the lever 3 to 4 times to the end of its stroke.

- 3) For the machine equipped with attachment control pedal, set the attachment lock cover to FREE position (F).
- 4) Operate the attachment repeatedly (approximately 10 times) to bleed the air completely from the attachment circuit.
 - For the machine equipped with attachment control pedal, operate the attachment control pedal repeatedly with running the engine at low idle.
 - For the machine equipped with proportional lever, operate the proportional switch or breaker operating switch repeatedly with running the engine at low idle.
- 5) After completion of air bleeding, stop the engine.
Halt the machine for 5 minutes or more.
- 6) Start the engine again.
This discharges the air mixed in the oil in the hydraulic tank.
- 7) Check that there is no oil leakage and wipe off any oil that is spilled.

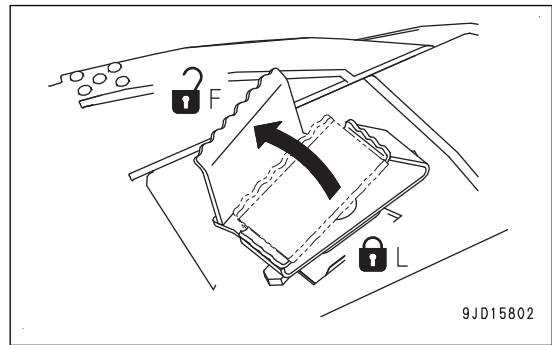

METHOD FOR CHANGING OVER HYDRAULIC CIRCUIT OF MACHINES WITH ATTACHMENT

Change over the hydraulic circuit corresponding to the attachment installed according to the following procedure.

1. Loosen wing nut (B), and remove selector valve stopper (A).
2. Change over the position of spool (1).

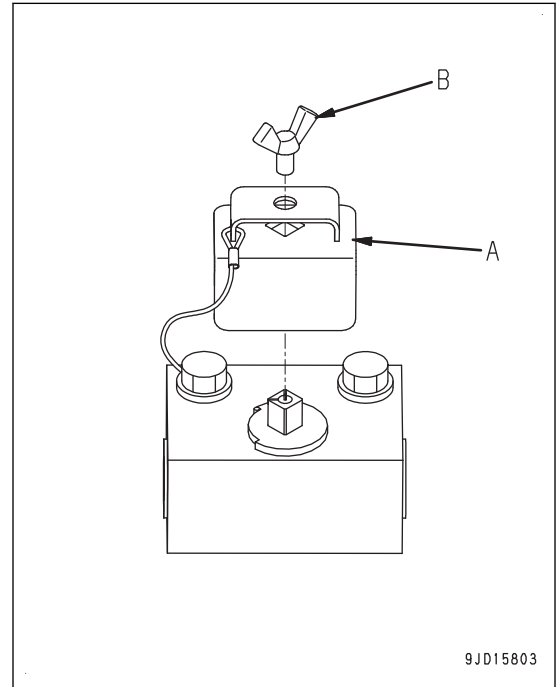

- When changing it to the position for breaker (1 way), turn spool (1) counterclockwise until it stops, and set it to position (b) for breaker (1 way).

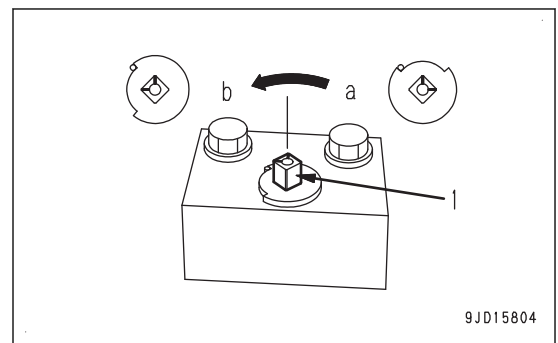

- When changing it to the position for general attachment such as crusher (2 way), turn spool (1) clockwise until it stops, and set it to position (a) for general attachment such as crusher (2 way).

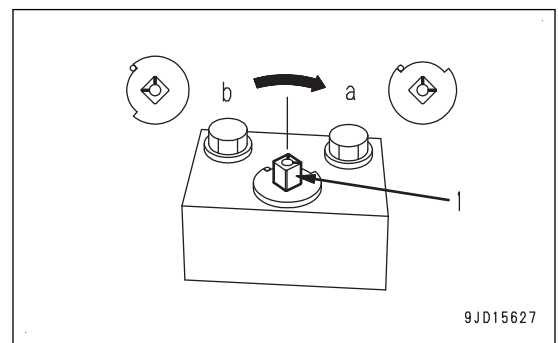

3. Install selector valve stopper (A) with wing nut (B).
After changing over, always install selector valve stopper (A).

METHOD FOR OPERATING ATTACHMENT

CHECK POINTS WHEN USING BREAKER

- Is selector valve (1) in position (b) for breaker (1 way)?
If it is not in position (b) for breaker (1 way), turn it to the position.

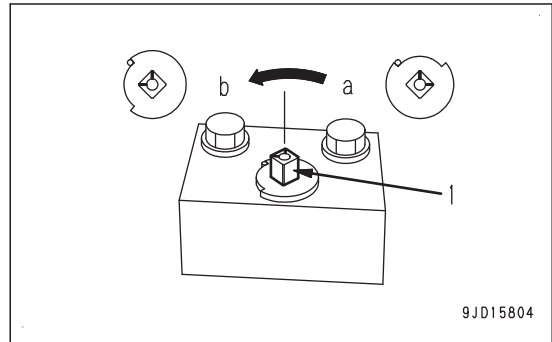

- Is engine output set at 80 %?
- Do you replace the hydraulic oil and its filter element at intervals shorter than the standard?
The deterioration of the hydraulic oil when using the breaker is much faster than in the normal operations, so check the maintenance time by referring to “MAINTENANCE INTERVAL FOR HYDRAULIC BREAKER”.
- When handling the breaker, follow the instruction manual from the manufacturer and use the breaker correctly.

METHOD FOR OPERATING MACHINE WHEN WORKING MODE IS NOT IN BREAKER MODE

If the working mode display does not indicate the breaker mode, set it to breaker mode according to the following procedure.

- Press function switch “F5” on the standard screen.
“Working Mode” screen is displayed.

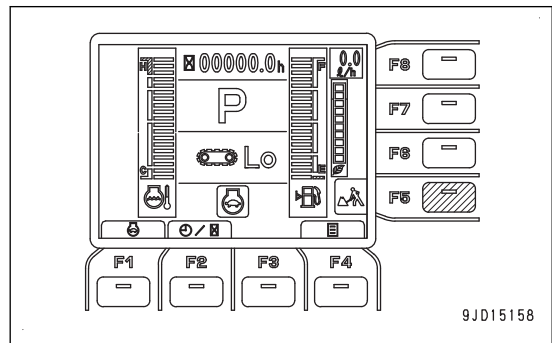

- Select breaker mode “B” with function switches “F1” or “F2” or “F5”.
- While breaker mode “B” is selected, press function switch “F4” or leave it as it is for 5 seconds.

Working mode is set to breaker mode “B”, and the screen returns to the standard screen.

REMARK

To return to the standard screen without changing the working mode, press function switch “F3”.

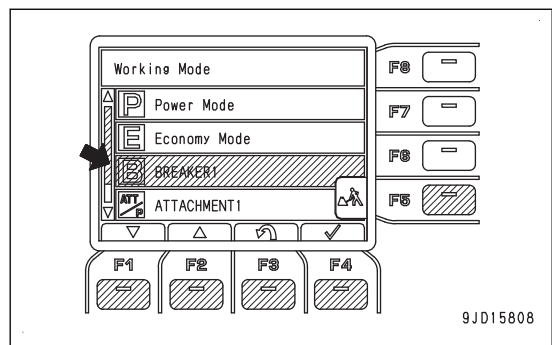

ADJUST BREAKER OIL FLOW RATE

- Breaker flow rate can be adjusted in 15 levels (“15” to “1”).
“15” is the maximum flow rate and “1” is the minimum flow rate.
Approximately 4 l/min per level can be changed.
- For the adjustment method of breaker flow rate, see “BREAKER SETTING”.

METHOD FOR OPERATING BREAKER

NOTICE

Use the breaker mode when performing breaker operations. Otherwise, the breaker will be damaged.

METHOD FOR OPERATING BREAKER OF MACHINES WITH ATTACHMENT CONTROL PEDAL

⚠ WARNING

- If the pedal is operated when the auto-deceleration is being actuated and the engine speed is dropped, the engine speed will suddenly increase, so be careful when operating.
- If you perform operations with your foot on the attachment control pedal, the attachment may suddenly move if you depress the pedal by mistake, and this may lead to serious personal injury or death.
Do not rest your foot on the attachment control pedal except when you operate the pedal.
- When the attachment is not used, set the attachment lock cover to LOCK position to prevent the attachment control pedal from moving.

1. Turn the fuel control dial to High idle (MAX) position, and return it a little bit.
Set the engine output at 80 % position (c).

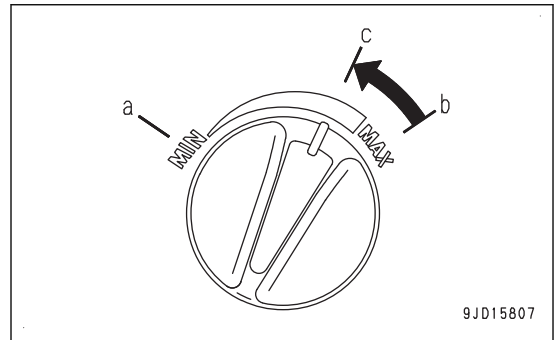

2. Set the attachment lock cover to FREE position (F).

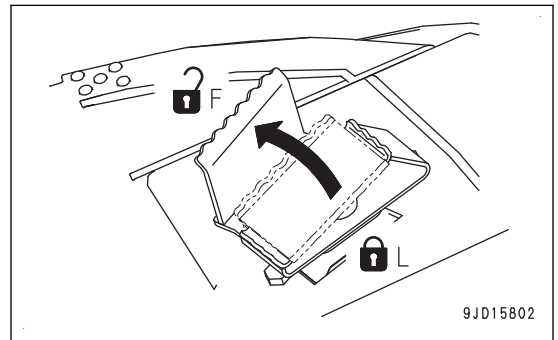

3. Depress the rear part of the attachment control pedal.

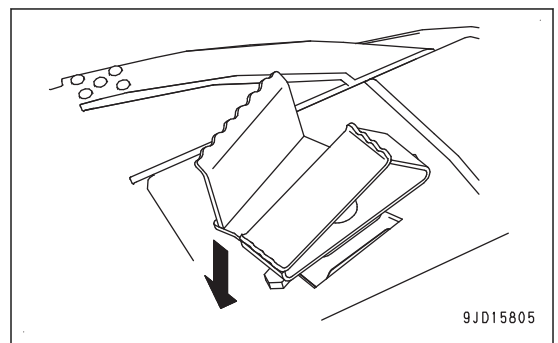

The breaker operates.

METHOD FOR OPERATING BREAKER OF MACHINES WITH PROPORTIONAL LEVER

⚠ WARNING

If you do not perform breaker operation or 2-way attachment operation, set the working mode to normal mode.

When the working mode is selected, if you press 1st-line attachment proportional switch or breaker operation switch by mistake, this may lead to serious personal injury or death.

1. Check that the working mode is set to the breaker mode B on the machine monitor.

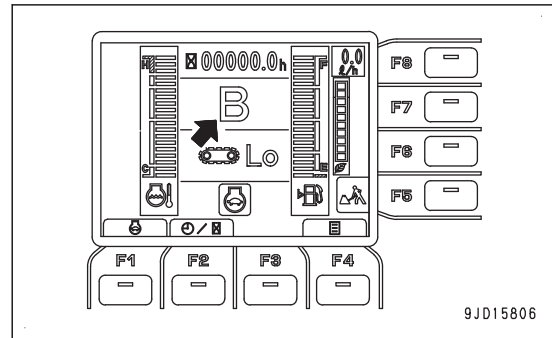

2. Turn the fuel control dial to High idle (MAX) position, and return it a little bit.
Set the engine output at 80 % position.

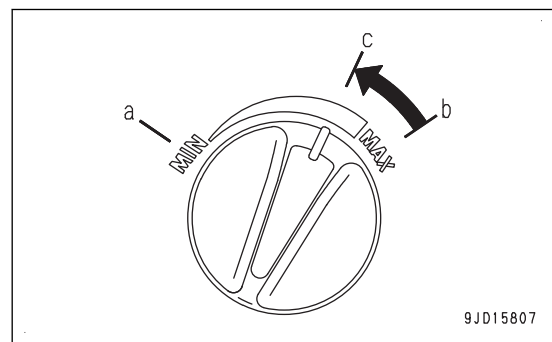

3. Press the breaker operation switch.

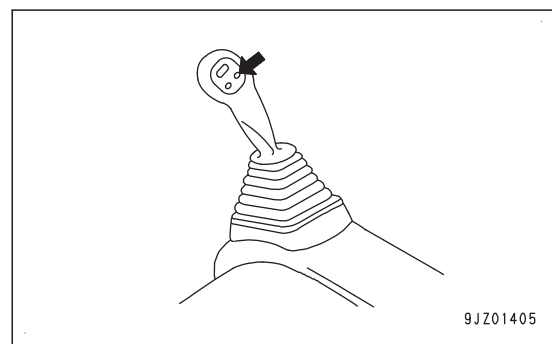

The breaker operates.

CHECK POINTS WHEN USING GENERAL ATTACHMENT SUCH AS CRUSHER ETC

- Is selector valve (1) in position (a) for general attachment such as crusher, etc. (2 way)?
If it is not in the position (a) for general attachment such as crusher, etc. (2 way), turn it to the position.

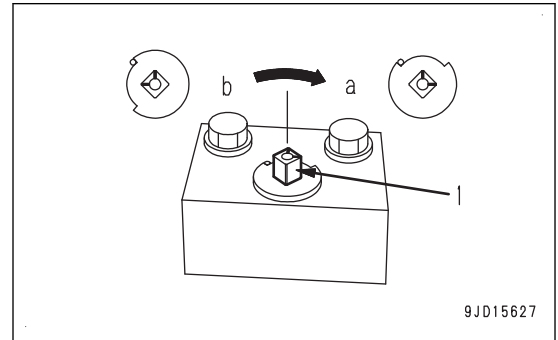

- When handling the general attachment such as crusher, etc., follow the instruction manual from the manufacturer and use the attachment correctly.

METHOD FOR OPERATING MACHINE WHEN WORKING MODE IS NOT IN ATT/P OR ATT/E FOR ATTACHMENT

If the working mode display does not indicate the attachment mode, set it to attachment mode according to the following procedure.

- Press function switch "F5" on the standard screen.
"Working Mode" screen is displayed.

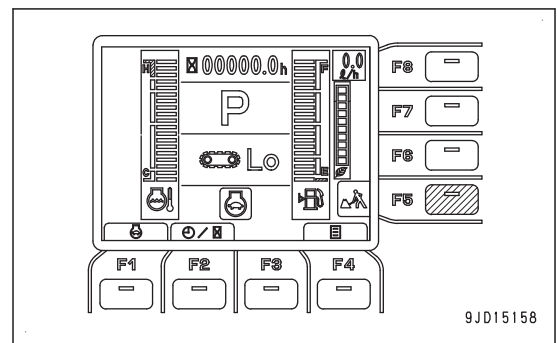

- Select attachment mode "ATT/P" or "ATT/E" with function switches "F1" or "F2" or "F5".
- While attachment mode "ATT/P" or "ATT/E" is selected, press function switch "F4" or leave it as it is for 5 seconds.
Attachment mode is set to "ATT/P" or "ATT/E", and the screen returns to the standard screen.

REMARK

To return to the standard screen without changing the working mode, press function switch "F3".

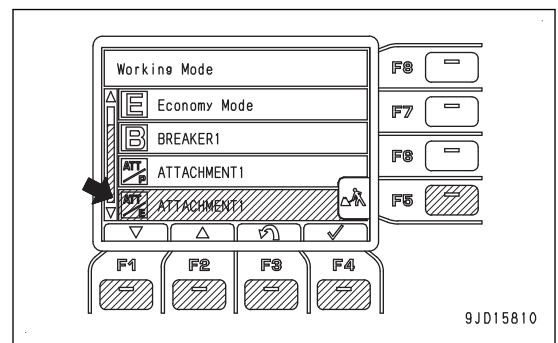

ADJUST OIL FLOW RATE OF GENERAL ATTACHMENT SUCH AS CRUSHER ETC

- Attachment flow rate can be adjusted in 8 levels ("8" to "1").
"8" is the maximum flow rate and "1" is the minimum flow rate.
Approximately 8 l/min per level can be changed.
- For the adjustment method for flow rate of general attachment such as crusher, etc., see "ATTACHMENT SETTING".

METHOD FOR OPERATING GENERAL ATTACHMENT SUCH AS CRUSHER ETC METHOD FOR OPERATING GENERAL ATTACHMENT SUCH AS CRASHER ETC OF MACHINES WITH ATTACHMENT CONTROL PEDAL

WARNING

- If the pedal is operated when the auto-deceleration is being actuated and the engine speed is dropped, the engine speed will suddenly increase, so be careful when operating.
- If you perform operations with your foot on the attachment control pedal, the attachment may suddenly move if you depress the pedal by mistake, and this may lead to serious personal injury or death.
Do not rest your foot on the attachment control pedal except when you operate the pedal.
- When the attachment is not used, set the attachment lock cover to LOCK position to prevent the attachment control pedal from moving.

1. Set the attachment lock cover to FREE position (F).

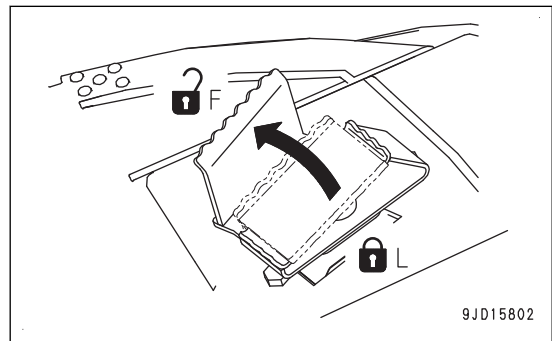

2. Depress the front or rear part of the attachment control pedal.

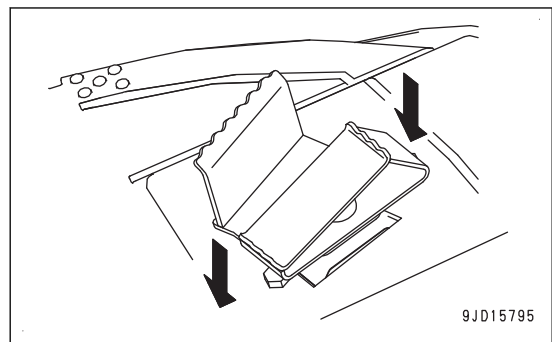

The attachment operates.

METHOD FOR OPERATING GENERAL ATTACHMENT SUCH AS CRASHER ETC OF MACHINES WITH PROPORTIONAL LEVER

WARNING

If you do not perform breaker operation or 2-way attachment operation, set the working mode to normal mode.

When the working mode is selected, if you press 1st-line attachment proportional switch or breaker operation switch by mistake, this may lead to serious personal injury or death.

1. Check that the working mode is set to attachment mode ATT/P or ATT/E on the machine monitor.

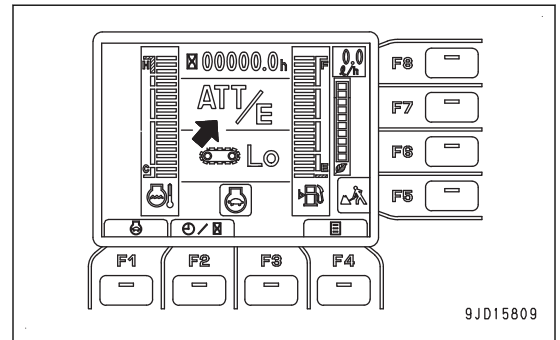

2. Operate attachment 1 proportional switch.

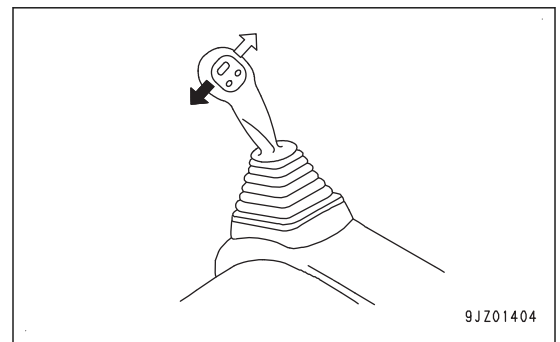

The attachment operates.

LONG-TERM STORAGE

NOTICE

If there is no breaker or general attachment installed, operating the attachment control pedal, 1st-line attachment proportional switch, or breaker operation switch may cause overheating and other problems.

If the equipment is not to be used for a long time, do as follows.

- Set the selector valve to the position for general attachment such as crusher.
- Lock the attachment control pedal with attachment lock cover.

SPECIFICATIONS

Hydraulic specifications

Max. flow rate (engine speed: at 2400 rpm)

70 ℓ/min

Safety valve setting pressure

17.2 MPa {175 kg/cm²}

OTHER TROUBLE

(For the machine equipped with proportional lever)

PHENOMENA AND ACTIONS FOR ELECTRICAL SYSTEM

- For the remedies indicated with (*) in the remedy column, always contact your Komatsu distributor.
- In cases of problems or causes which are not listed below, ask your Komatsu distributor for repairs.

Problem	Main causes	Remedy
Breaker does not operate even if the breaker operation switch is pressed.	Defective wiring	Check, repair. (*)

BATTERY DISCONNECT SWITCH

CAUTION

- Do not operate the battery disconnect switch while the engine is running. The large current generated by the alternator may burn the electric parts and cause a fire. When operating the battery disconnect switch, always stop the engine.
- If the battery disconnect switch is turned to OFF position, always remove the switch key. If someone turns the key to ON position carelessly, this is extremely dangerous.

NOTICE

- Keep battery disconnect switch in ON position except the following cases.
 - When the machine is stored for a long time (more than a month)
 - When repairing the electrical system
 - When performing electric welding
 - When handling the battery
 - When replacing the fuse, etc.
- Do not turn the battery disconnect switch to OFF position while the system operating lamp is lit. If it is turned OFF while this lamp is lit, the data in the controller may be lost.
- If this switch is turned to OFF position, all the electrical system is cut out and the functions of KOM-TRAX stop. In addition, the time information of the clock and the radio (if equipped) tuning information may be lost. In this case, set the information again. For detail, see “CLOCK ADJUSTMENT” and “HANDLE RADIO”.

Battery disconnect switch (1) is used to cut out the electricity from the battery.

This is installed in the battery box inside the dirt cover.

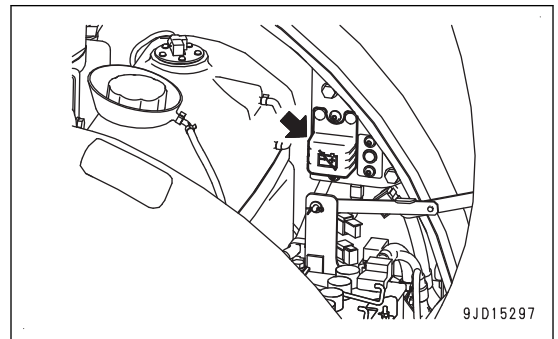

Raise rubber cover (2), and battery disconnect switch (1) is seen.

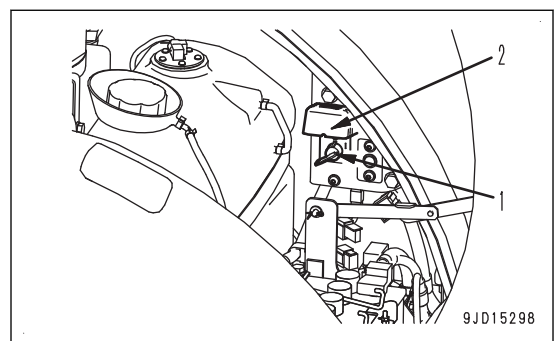

REMARK

Operate this switch while the system operating lamp is off.

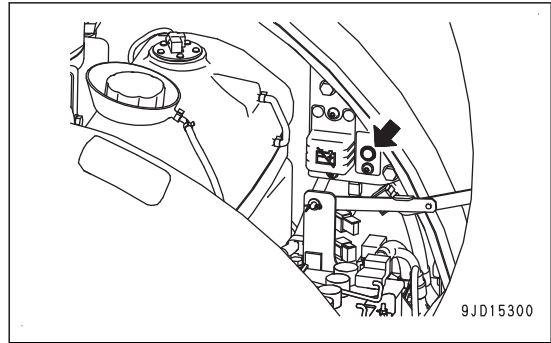
**(O) OFF position**

Switch key (1) can be pulled out (and inserted) and the current from the battery is cut out.

(I) ON position

The current from the battery flows into the circuit.

Before starting the machine, be sure to set the switch to this position.

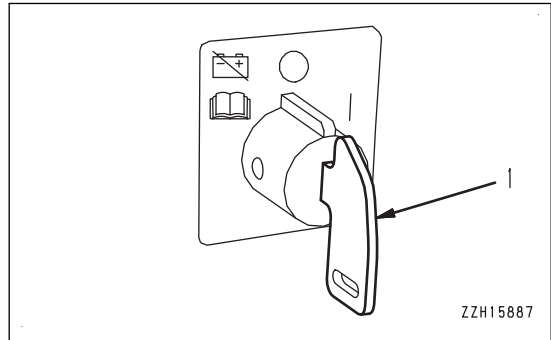

SYSTEM OPERATING LAMP

The system operating lamp indicates that the controller mounted on the machine is turned ON.

System operating lamp lights up in green when the controller is turned on and goes out in a few minutes after the starting switch is turned to OFF position.

Before operating the battery disconnect switch, check that system operating lamp is not lit.

NOTICE

If the battery disconnect switch is turned to OFF position (O) while the system operating lamp is lit, the data in the controller may be lost.

If the data are lost, when you try to start the engine next time, "L04" is displayed on the machine monitor and the engine may not start.

If the engine cannot be started, ask your Komatsu distributor for inspection and repair.

REMARK

- Even if the starting switch is in OFF position, the controller may operate. The system operating lamp lights up at this time, but it is not a failure.
- After the starting switch is turned to OFF position, if the system operating lamp stays lit for a long time, consult your Komatsu distributor.
- The system operating lamp may look slightly luminous in the dark when it is not lit. It is due to the minute leakage of current and this is not an abnormal phenomenon.

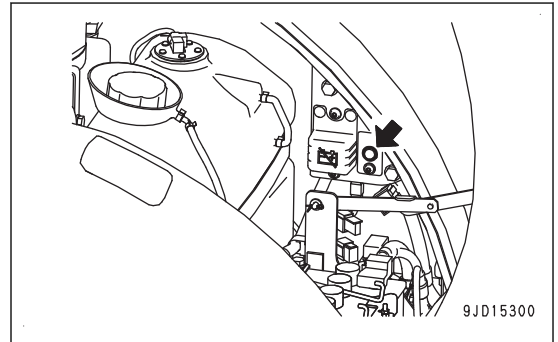

HANDLE HEATER

EXPLANATION OF HEATER COMPONENTS

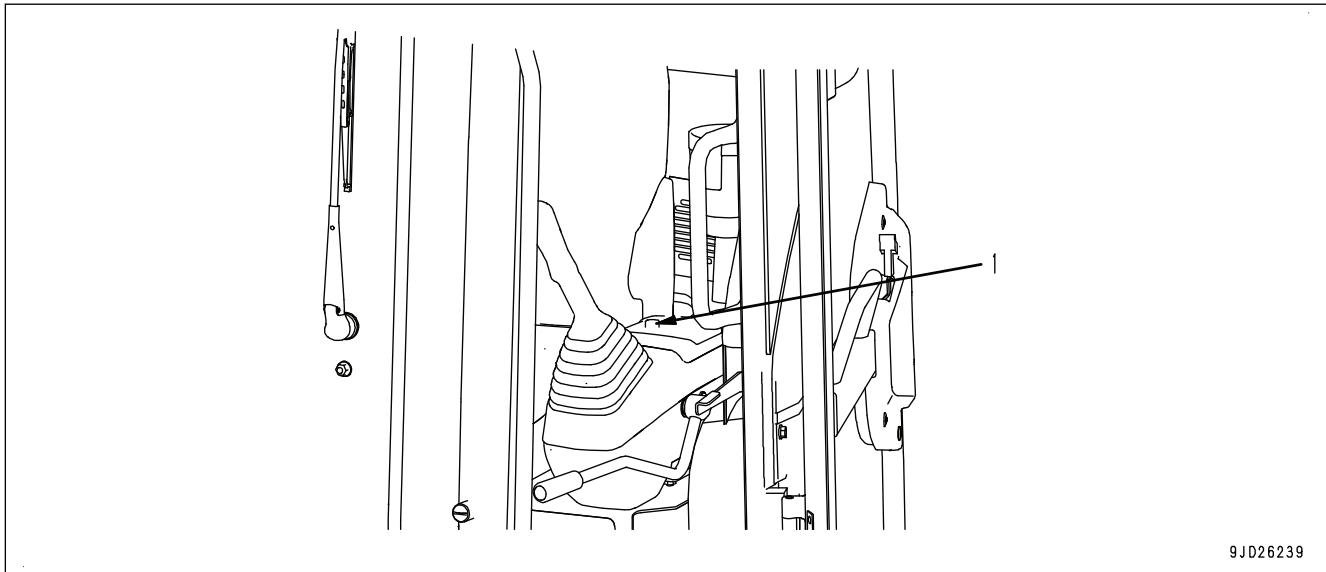

9JD26239

(1) Heater switch

HEATER SWITCH

Heater switch is used to warm up inside of operator's compartment.

Warm air flow can be adjusted in 2 levels with heater switch.

Use this switch after the engine coolant is warmed up.

Position 0

Stops the air flow.

Position 1

Operates with air flow at low.

Position 2

Operates with air flow at high.

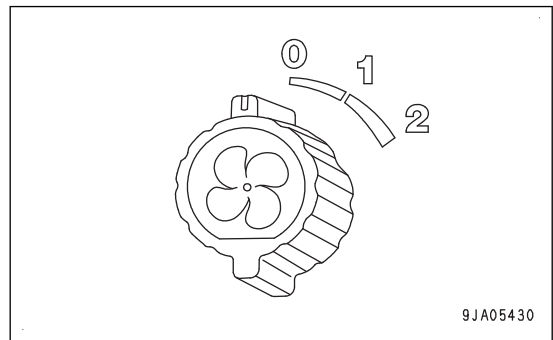

9JA05430

METHOD FOR USING HEATER

If the ambient temperature is low, use the heater.

1. Pull the engine rear cover (1) backward to open it.
Open the engine rear cover (1) fully and it is secured by rod (2).
2. Turn the valve attached to the water manifold counter-clockwise to open.
3. Close the engine rear cover (1).
4. Turn the heater switch to adjust the air flow rate.
If the heater is not used for a long time, turn the valve clockwise to close it.

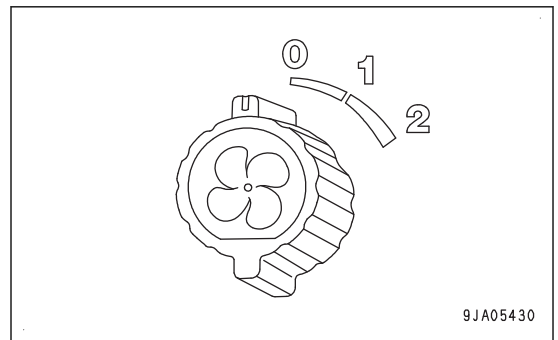
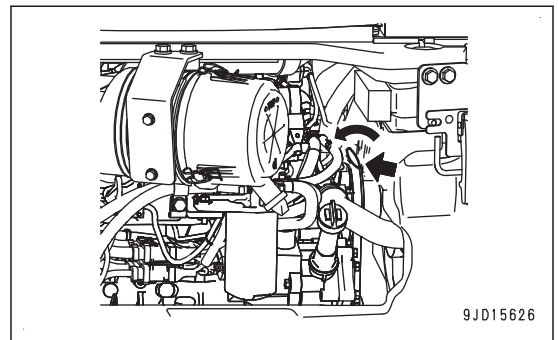
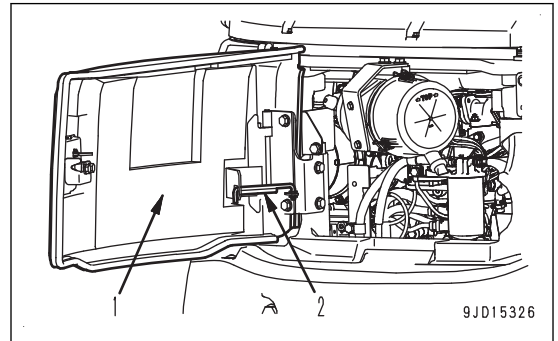

HANDLE RADIO

- To ensure safety, always keep the volume to a level where you can hear the outside sounds during operation.
- If water gets into the speaker case or radio, it may lead to failure. Take care not to let water get on them.
- Do not wipe the display or buttons with solvent such as benzene or thinner. Wipe with a dry soft cloth.
- When the battery disconnect switch is turned to OFF position or the power for the machine is turned off for the replacement of the battery, the clock may be initialized. In such a case, set it again.

EXPLANATION OF RADIO EQUIPMENT

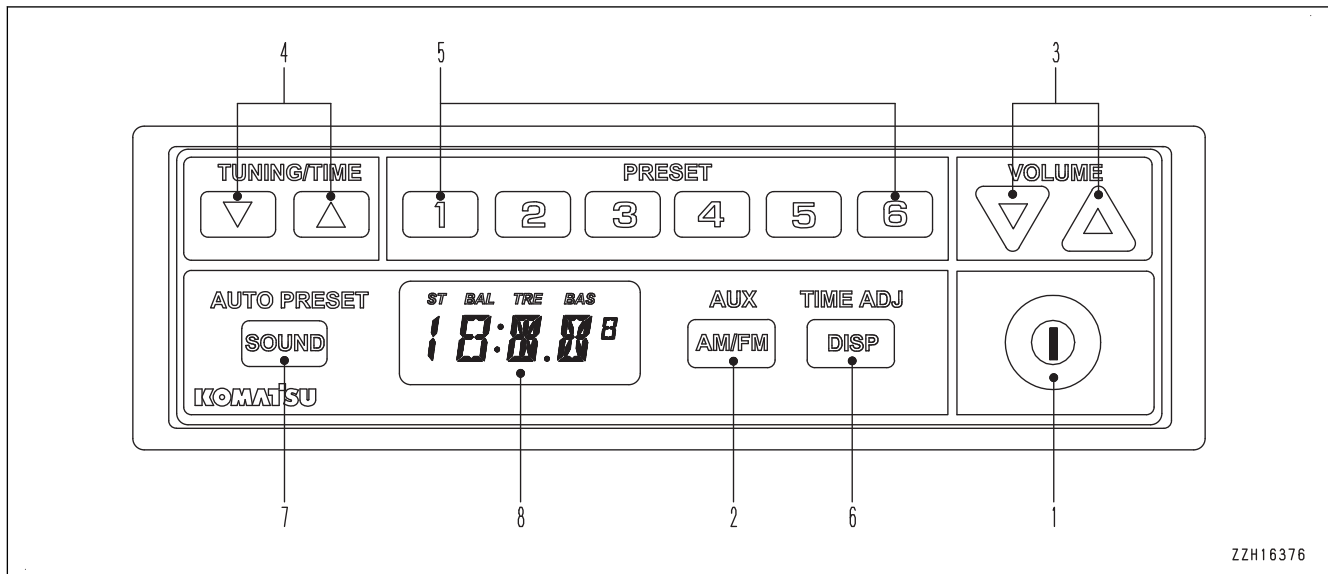

- | | |
|-----------------------------------|-----------------------------|
| (1) Power button | (5) Preset button |
| (2) Band/AUX selector button | (6) Display selector button |
| (3) Volume control button | (7) Sound control button |
| (4) Tuning/time adjustment button | (8) Display |

POWER BUTTON

Press the power button to supply the power to the radio and the frequency is displayed on the display. As long as AUX is selected, "AUX" is displayed on the display.

Press the power button again to turn off the power.

BAND/AUX SELECTOR BUTTON

Press band/AUX selector button to select the desired band or "AUX".

By pressing band/AUX selector button, the display changes FM → AM → AUX → FM ...

VOLUME CONTROL BUTTON

Use the volume control button to control the volume.

Press the Δ button, and the volume increases. Press the ∇ button, and the volume decreases. The range for the volume is 0 to 32.

Hold down the volume control button, and you can change the volume continuously.

TUNING/TIME ADJUSTMENT BUTTON

Use the tuning/time adjustment button to select frequency and step for sound adjustment and to adjust time.

PRESET BUTTON

If you register the desired stations to the preset button beforehand, you can select each station by touching this button once.

It is possible to preset 6 stations each for both AM and FM.

DISPLAY SELECTOR BUTTON

Use the display selector button to change the display between frequency and clock.

Each time you press the display selector button, frequency, clock and band name are shown on the display in this order.

While a band name is displayed, after 1.5 seconds elapsed, a frequency will be displayed again.

As long as AUX is selected, this button alternately switches the display between AUX and the clock.

SOUND CONTROL BUTTON

Press the sound control button, and the sound adjustment is ready.

Each time sound control button is pressed, BAL (Balance), TRE (Treble) and BAS (Bass) will be selected in this order.

If sound control button is pressed while BAS is displayed, the sound adjustment will be canceled.

DISPLAY

(A): Band name, "AUX", frequency, clock and other character/numeric information are displayed.

(B): Frequencies are displayed at steps of 50 kHz in certain areas.

(C): Lights up when a stereo broadcasting is heard while a FM station is selected.

(D): Lights up at the time of balance adjustment in the sound adjusting condition.

(E): Lights up at the time of treble adjustment in the sound adjusting condition.

(F): Lights up at the time of bass adjustment in the sound adjusting condition.

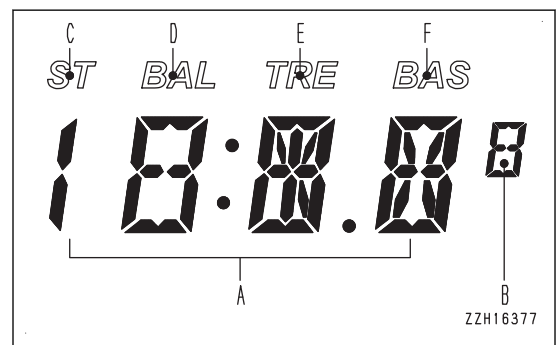

AUX

NOTICE

- A stereo miniature plug can be connected.
Read the instruction manual of the equipment to connect carefully.
- As a power source, use the battery attached to the equipment to connect.
If you use an electric power supply installed to the machine, the noise may occur.
- The noise may occur if you pull out the input plug when AUX is selected, or if you push in or pull out the plugs of the equipment to connect.

You can hear the sound through the speaker of the machine when you connect a commercially available portable audio equipment to the machine.

1. Open cap (A) at the rear right of the operator's seat.
2. Connect a portable audio equipment by using an commercially available audio cable.

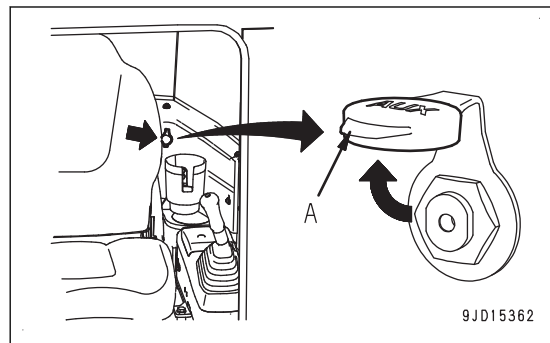

3. Press band/AUX selector button (1) to select "AUX".

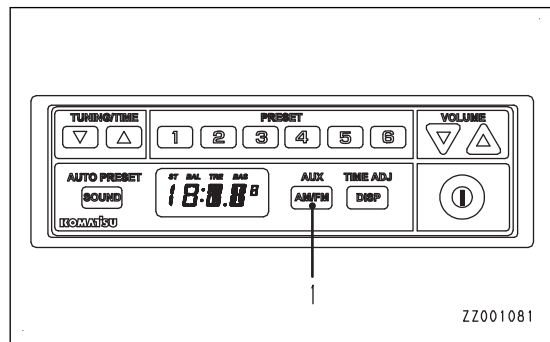

METHOD FOR CONTROLLING RADIO

METHOD FOR ADJUSTING FREQUENCY

1. Press band/AUX selector button (1) and select FM or AM.
2. Press tuning/time adjustment button (2) to adjust the frequency.

- Press the Δ button, and the frequency increases; press the ∇ button, and the frequency decreases.
- Hold down the Δ button, and the frequency increases continuously; hold down the ∇ button, and the frequency decreases continuously.
- Hold down the Δ button and release it, then the frequency increases continuously. Hold down the ∇ button and release it, then the frequency decreases continuously as an auto seek. When a proper frequency is picked up, the tuning automatically stops.

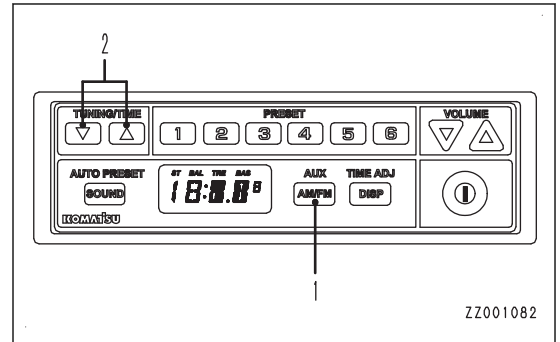

ZZ001082

METHOD FOR ADJUSTING FREQUENCY (AUTO PRESETTING)

1. Press band/AUX selector button (1) and select FM or AM.
2. Hold down sound control button (2).

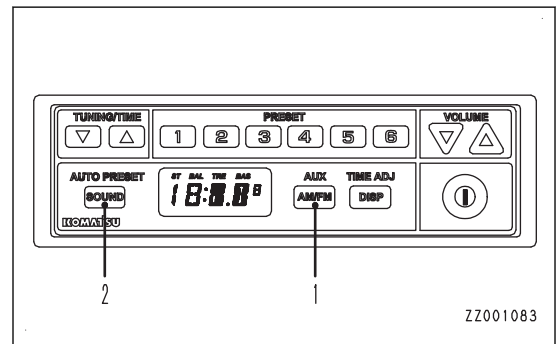

ZZ001083

When a proper frequency is picked up, it is automatically registered to preset memories 1 to 6.

METHOD FOR CALLING PRESET

1. Press band/AUX selector button (1) and select FM or AM.
2. Press one of 1 to 6 of preset button (2).

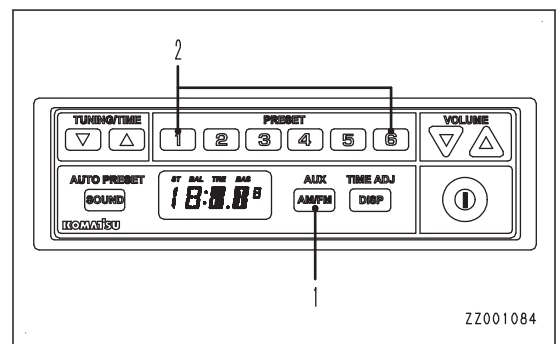

ZZ001084

The frequency registered in the preset number of the pressed button is called up and received.

“Example”

While a frequency is displayed, press button 1 of preset button (2), and the preset number “P-1” is displayed on the display.

The preset number is shown for 0.5 seconds, and then the frequency is displayed.

METHOD FOR REGISTERING PRESET

Hold down one of 1 to 6 of preset button (1) while listening to the radio.

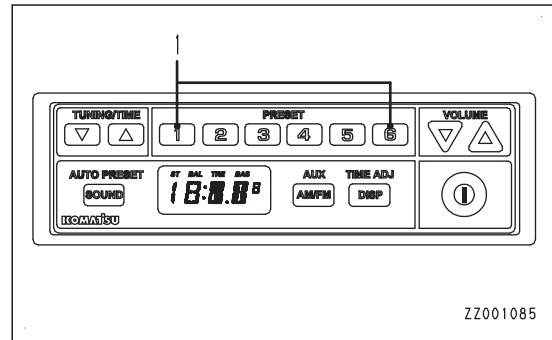

The currently received frequency is registered to the preset number corresponding to the pressed button.

“Example”

While a frequency is displayed, hold down the button 1 of preset button (1), and the preset number “P-1” is displayed.

After the preset number flashes 3 times, the frequency is displayed and then registered to preset number “P-1”.

METHOD FOR ADJUSTING SOUND BALANCE

1. Press sound control button (1) to light up “BAL” on the display.

You can adjust the sound (balance).

2. Press tuning/time adjustment button (2) to adjust the sound (balance).

- Press the Δ button, and the speaker output on the R side increases by 1. (R1 to R7)
- Press the ∇ button, and the speaker output on the L side increases by 1. (L1 to L7)

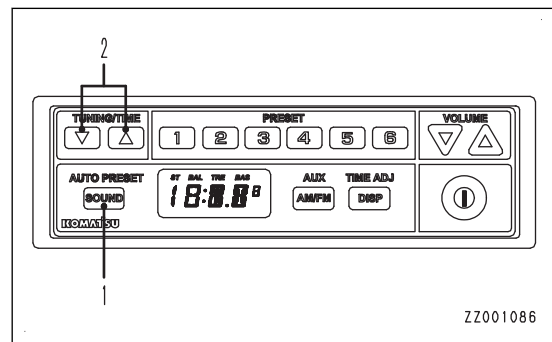

METHOD FOR ADJUSTING HIGH REGISTER RANGE (TREBLE)

1. Press sound control button (1) to light up “TRE” on the display.

You can adjust the high register range (treble) of the sound.

2. Press tuning/time adjustment button (2) to adjust the high register range (treble).

- Press the Δ button, and the high register range (treble) level increases by 1. (Maximum +7)
- Press the ∇ button, and the high register range (treble) level decreases by 1. (Minimum -7)

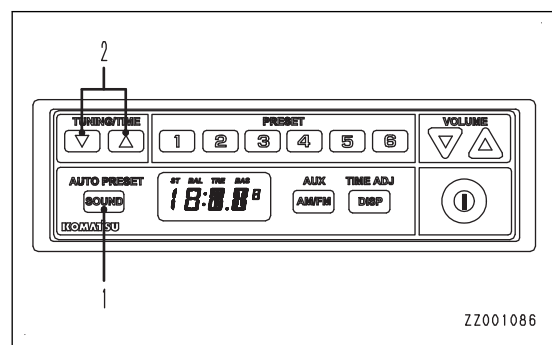

METHOD FOR ADJUSTING LOW REGISTER RANGE (BASS)

1. Press sound control button (1) to light up “BAS” on the display.

You can adjust the low register range (bass) of the sound.

2. Press tuning/time adjustment button (2) to adjust the low register range (bass).

- Press the Δ button, and the low register range (bass) level increases by 1. (Maximum +7)
- Press the ∇ button, and the low register range (bass) level decreases by 1. (Minimum -7)

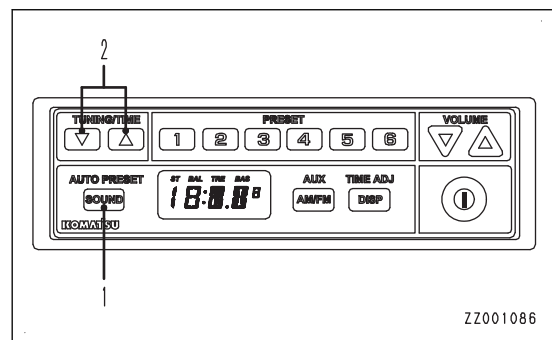

METHOD FOR ADJUSTING CLOCK

1. Press display selector button (1) to display the clock.
2. Hold down display selector button (1) to flash the "HOUR" display portion.
You can adjust the hour.
3. Press tuning/time adjustment button (2) to adjust the hour.
 - If you press Δ button, "HOUR" display increases by 1.
 - If you press ∇ button, "HOUR" display decreases by 1.
4. Press display selector button (1) to flash the "MINUTE" display portion.
You can adjust the minute.
5. Press tuning/time adjustment button (2) to adjust the minute.
 - If you press Δ button, "MINUTE" display increases by 1.
 - If you press ∇ button, "MINUTE" display decreases by 1.
6. Press display selector button (1) to cancel time adjustment.
The screen returns to clock display.

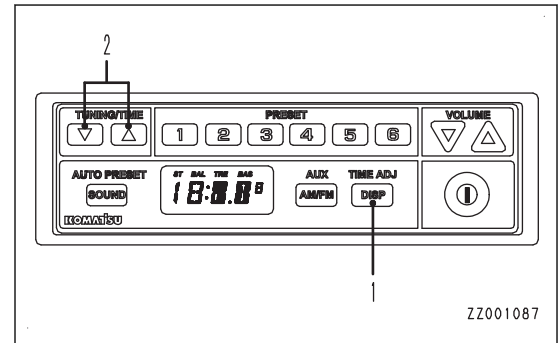

ZZ001087

STOW ANTENNA

Before transporting the machine or putting it inside a building, stow the antenna to prevent any interference.

1. Loosen the antenna mounting bolt (1) and stow the antenna at the stowage position (A).
2. After stowing the antenna, tighten the mounting bolt (1).

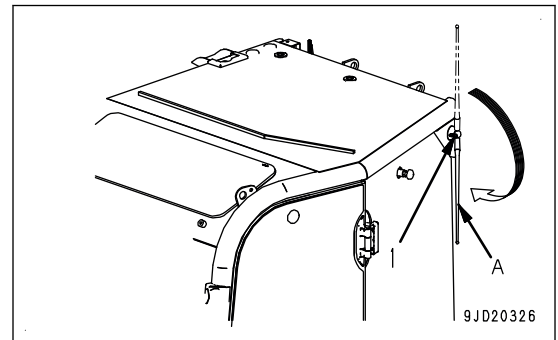

9JD20326

CONTROL PATTERNS OTHER THAN STANDARD CONTROL METHOD (FOR MACHINES EQUIPPED WITH OPERATION PATTERN CHANGE-OVER VALVE)

WARNING

- When operating the machine, check that the display of the control pattern card is matched to the operation of the machine to prevent personal injury by malfunction. If it does not match, replace it immediately with the correct control pattern card.
- When checking the movement of the machine, operate slowly while paying attention to the safety around the machine.
- Stop the engine, and check that the lock lever is in LOCK position, and change the control pattern of the machine.

NOTICE

The control pattern cards are replaceable.

If the control pattern is changed, replace the control pattern card with the one for the new control pattern.

The control pattern card is located at the position shown in the figure.

Machine with canopy specification

The control pattern card is located on the right side of the operator's seat.

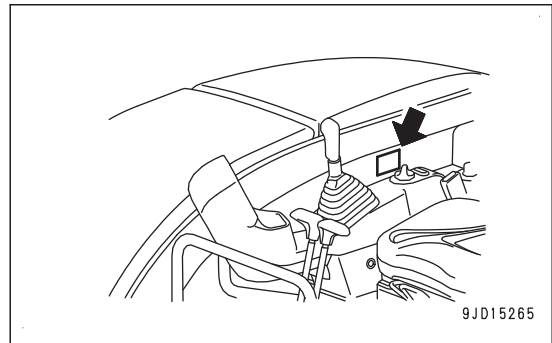

Machine with cab specification

The control pattern card is located on the right side of the operator's seat.

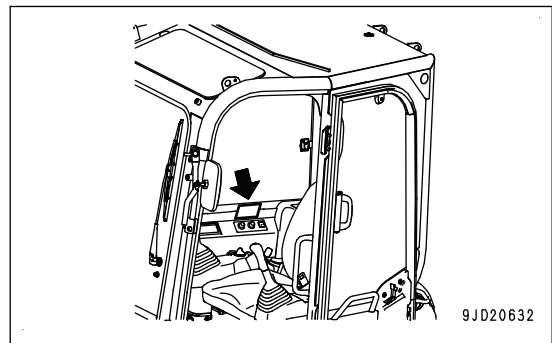

The preferable control pattern can be selected for the work equipment control lever.

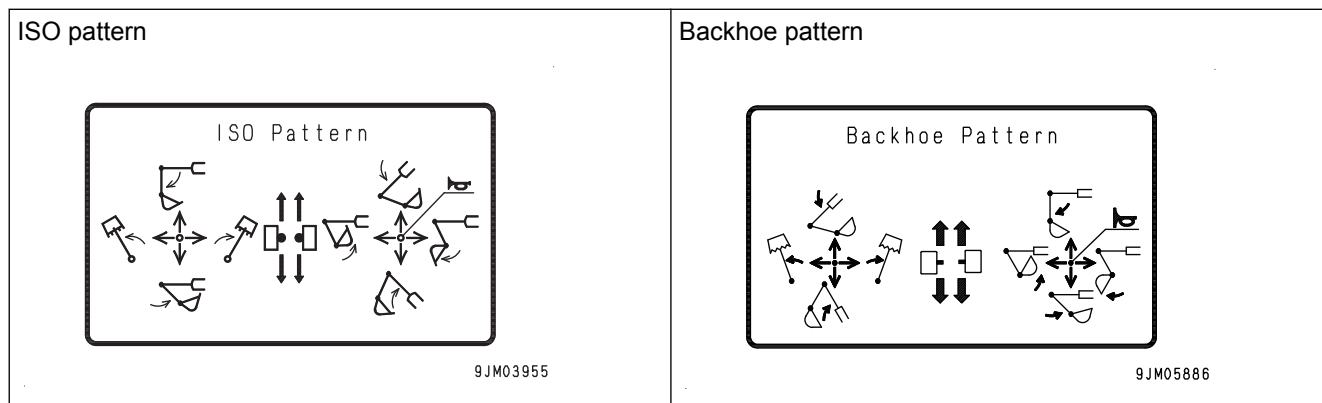

METHOD FOR CHANGING CONTROL PATTERNS

⚠ WARNING

- When operating the machine, check that the display of the control pattern card is matched to the operation of the machine to prevent personal injury by malfunction. If it does not match, replace it immediately with the correct control pattern card.
- When checking the movement of the machine, operate slowly while paying attention to the safety around the machine.
- Stop the engine, and check that the lock lever is in LOCK position, and change the control pattern of the machine.

1. Set the machine in the parking posture, stop the engine, and set the lock lever to LOCK position (L).
Be sure to operate the lock lever by the operating portion on the top.
2. Open the inspection window at the bottom left of the machine.
Open the inspection window at the bottom left side of the machine, and the changeover valve is seen.

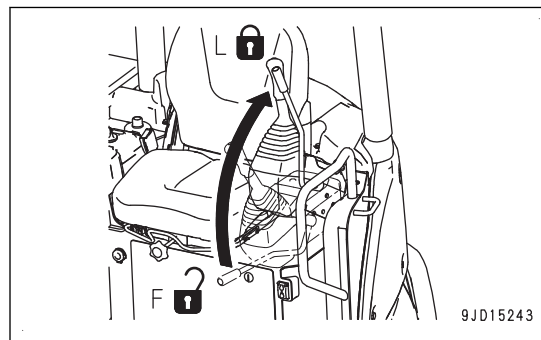

3. Loosen the hexagonal socket head bolt (1).
4. Set the lever (2) to a desired pattern by using the special tool.

Position (a)

ISO pattern

Position (b)

Backhoe pattern

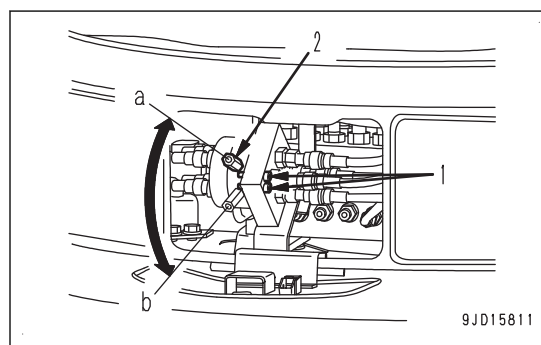

5. After changing the control pattern, tighten the hexagonal socket head bolt (1) securely.
6. Close the inspection window at the bottom left side of the machine.
7. Replace the control pattern card according to the selected control pattern.
The control pattern card is in-case type and can be easily replaced.

Machine with canopy specification

The control pattern card is located at the right side of the operator's seat.

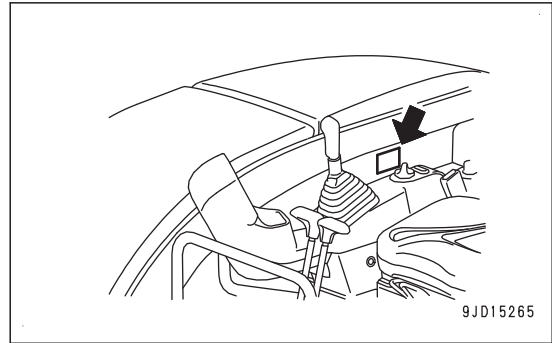

Machine with cab specification

The control pattern card is located at the right side of the operator's seat.

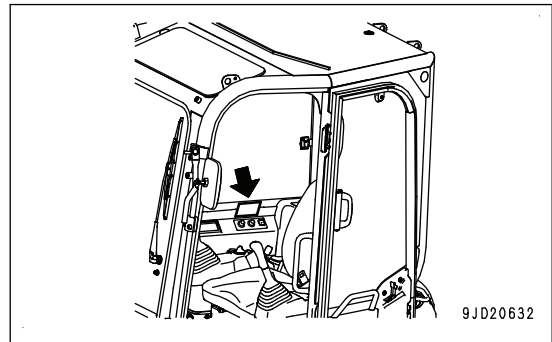

8. Start the engine and set the lock lever in FREE position (F).
Be sure to operate the lock lever by the operating portion on the top.
9. Operate the work equipment control levers slowly to check that the control pattern has been changed.

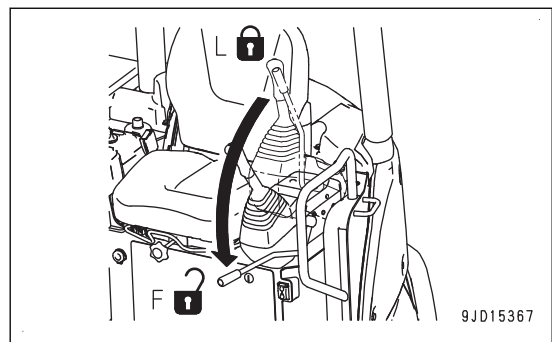

ATTACHMENTS AND OPTIONS

WARNING

- Read the instruction manual for the attachment and the sections of this manual related to attachments and options.
- Installing any attachment or optional equipment is related to the safety issue. Contact your Komatsu distributor before installing.
- Installing attachments or optional equipment without consulting your Komatsu distributor may not only cause problems with safety, but may also have an adverse effect on the operation of the machine and the life of the equipment.
- Any personal injuries, product failures, physical loss or damage resulting from the use of unauthorized attachments or parts will not be the responsibility of Komatsu.

INSTALL ATTACHMENT

WARNING

Depending on the type or combination of work equipment, there is a danger that the work equipment may hit the cab or machine body.

When using unfamiliar work equipment for the first time, check before starting if there is any danger of interference, and operate it with care.

Table of the combination of attachments which can be installed to the standard arm and long arm

○: Can be used

△: Can be used only for light duty work

x: Cannot be used

NOTICE

- When the long arm is equipped, if the bucket is drawn to the machine body, the arm interferes with the body. Operate the long arm carefully.
- When the boom is fully lowered during oblique digging, the boom interferes with the undercarriage. Operate the boom carefully.

Categories of use

Select a proper attachment for each use.

For general digging: Digging or loading sand, gravel, clay etc.

For light duty digging: Digging or loading dry and loose earth and sand, mud etc.

For loading: Loading of dry and loose earth

REMARK

For digging or loading hard soil or soft rock, the reinforced bucket having high durability and wear and abrasion resistance is recommended.

Name	Capacity (m ³ { cu.yd })	Opening width (Body) (mm { in })	Use	Standard arm	Long arm
Standard bucket	0.14 {0.18}	600 {23.6}	General digging	○	x
Narrow bucket	0.11 {0.14}	500 {19.7}	Narrow digging	○	○

RECOMMENDED ATTACHMENT OPERATIONS

The following descriptions are the precautions which must be followed when operating the hydraulic excavator equipped with an attachment.

NOTICE

Select the optimum attachment model for the hydraulic excavator body.

The attachments and models ready for installation differ according to the machine body. For details of the selection of the attachments or the models, consult your Komatsu distributor.

HYDRAULIC BREAKER

Applicable work

Major works suitable to the hydraulic breaker are as follows.

- Demolition work
- Crushing rock
- Road construction

This attachment can be used for a wide range of applications including demolition of buildings, breaking up road surfaces or slag, tunnel work, rock crushing and breaking operations in quarries.

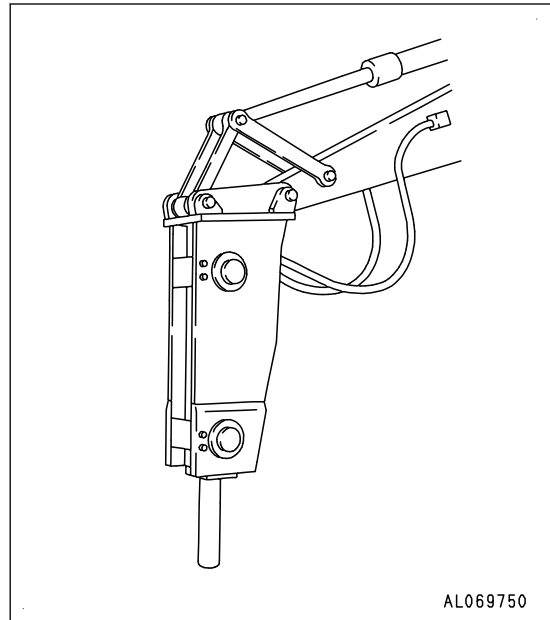

Precautions when performing breaking operations

Keep the chisel pushed perpendicularly against the impact surface when performing breaking operations.

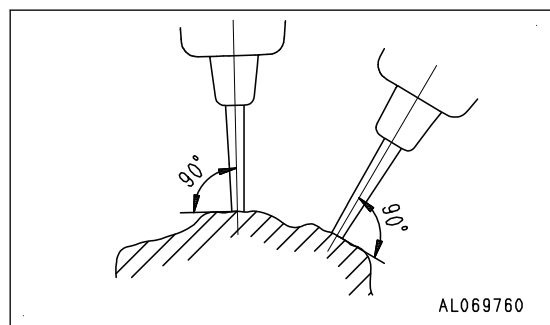

Push the chisel against the impact surface and operate so that the chassis rises approximately 5 cm {approximately 2 in} off the ground.

Do not let the machine come further off the ground than this amount.

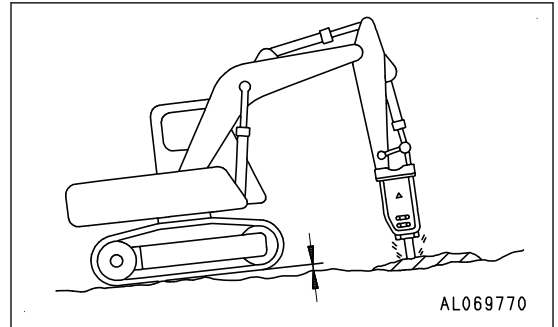

When the chisel does not penetrate or break the surface by continuous impact to the same impact surface for 1 minute, change the point of impact and perform breaking operations by scraping from the edge.

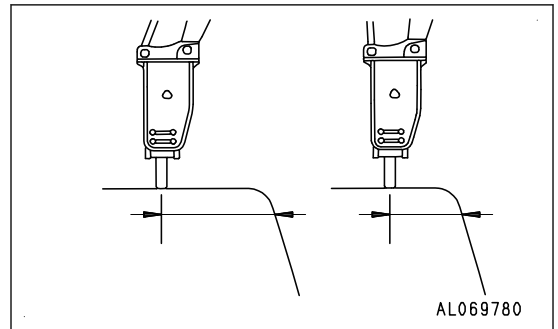

The direction of penetration of the chisel and the direction of the breaker body will gradually move out of line with each other, always adjust the bucket cylinder to keep them aligned.

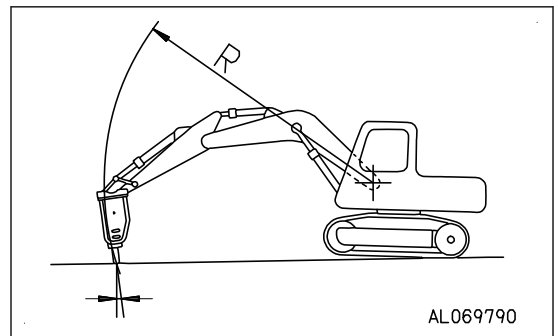

Always keep the chisel pressed against the impact surface properly not to strike at the air.

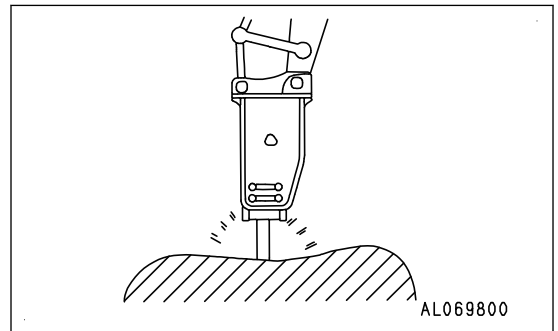

Prohibited operations

To ensure that the machine has a long life, and to ensure that operations are performed in safety, do not operate the machine in any of the following ways.

Do not operate all cylinders to the end of their strokes. Always leave approximately 5 cm {approximately 2 in} to spare.

Do not use the mount to gather in pieces of rock.

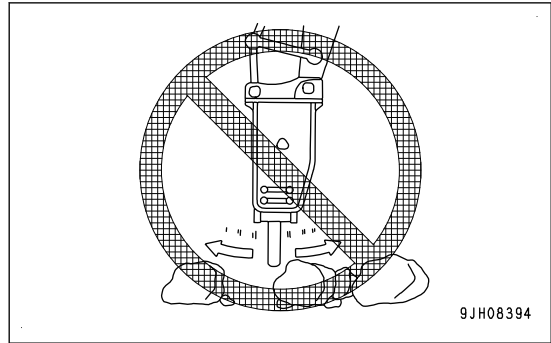

Do not work by using the swing force.

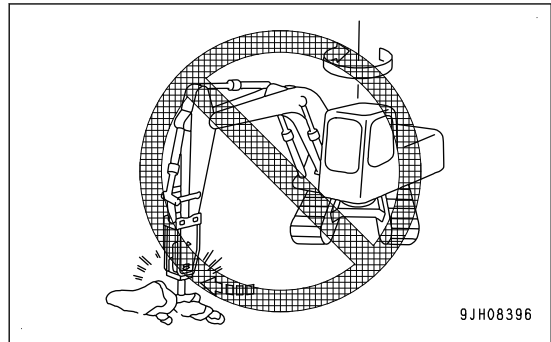

Do not move the chisel while performing breaking operation.

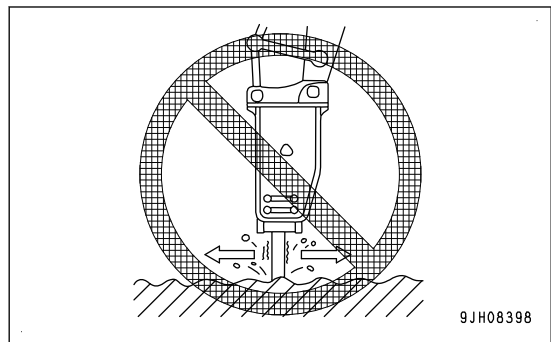

Do not perform breaker operation in horizontal or upward direction.

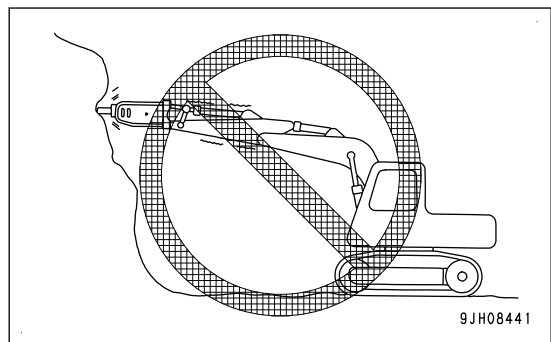

Do not work under water.

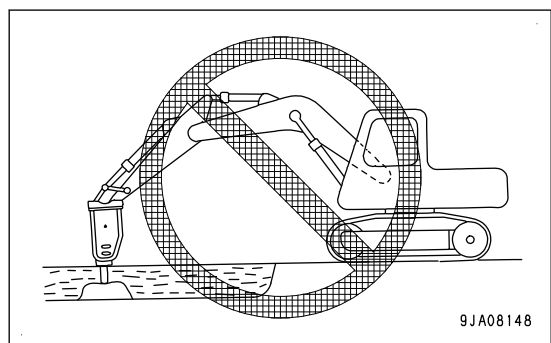

Do not pry the ground or rock with the chisel penetrated.

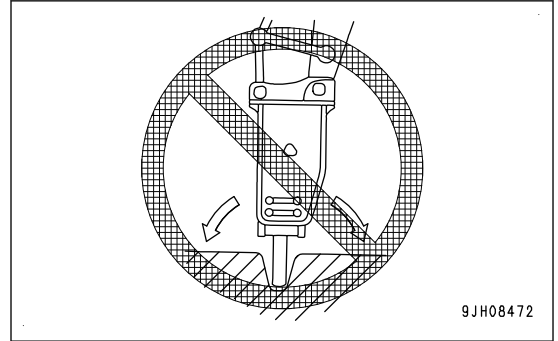

Do not perform pick work.

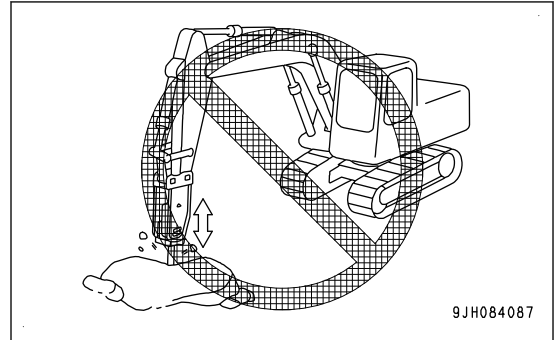

Extending the bucket cylinder rod fully and thrusting to raise the machine off the ground

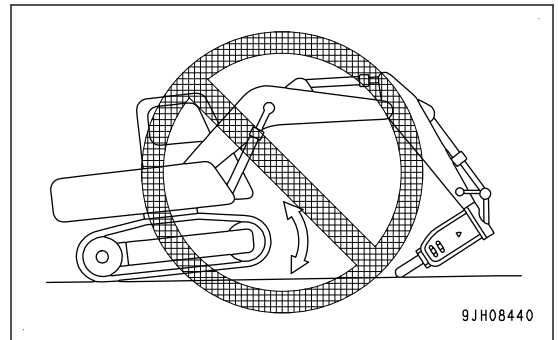

Do not perform breaker work with any cylinder at the stroke end.

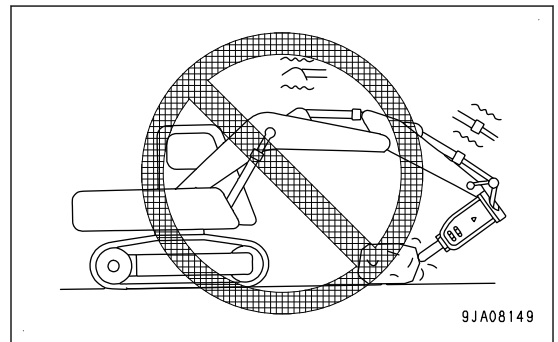

When greasing the hydraulic breaker, set it in the specified posture.

NOTICE

If the breaker is greased in an improper posture, it is filled with more grease than necessary. As a result, dirt will enter the hydraulic circuit and can damage the hydraulic components while the breaker is in use.

Be sure to grease the breaker, keeping it in the right posture.

Grease the breaker while keeping it in the right posture shown below.

1. Lower the chisel to the ground perpendicularly.
2. Insert the grease pump perpendicularly to the greasing point.

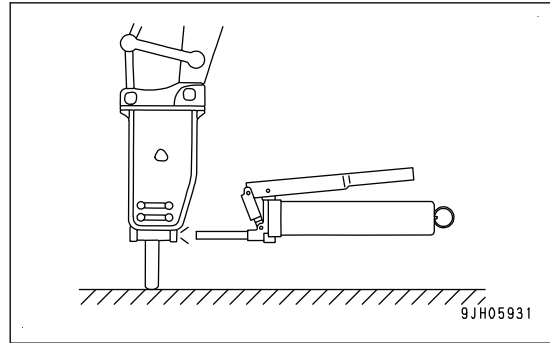

Wrong posture

Do not perform greasing when the hydraulic breaker is lowered to the ground.

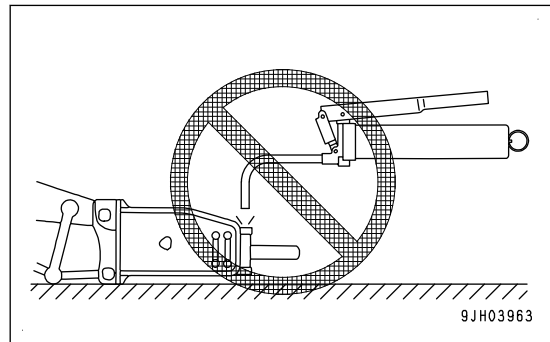

Do not perform greasing when the chisel is not lowered to the ground.

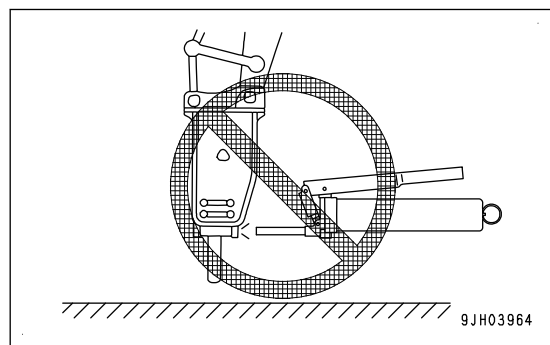

BREAKERS

WARNING

When the machine is used with the breaker installed, its safety decreases because the weight of the breaker is larger and the work contents of the breaker is less safe than that of the bucket.

Do not operate the machine sharply since the machine may tip over. Before working with the breaker, take protective measures from broken pieces.

Applicable work

Major works suitable to the breaker are as follows.

- Cutting reinforcing bars and steel frames
- Demolition of concrete structures

Prohibited operations

To ensure that the machine has a long life, and to ensure that operations are performed in safety, do not operate the machine in any of the following ways.

Do not operate all cylinders to the end of their strokes. Always leave approximately 5 cm {2 in} to spare.

Do not work with any cylinder at the stroke end.

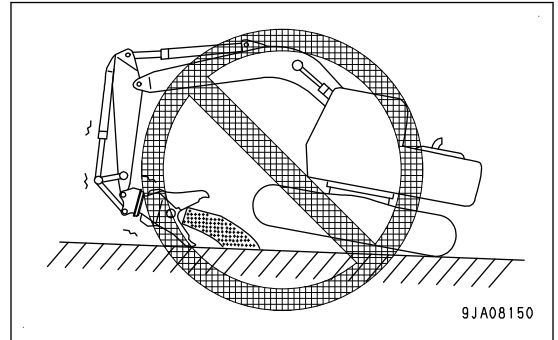

Do not work with the machine directed sideways.

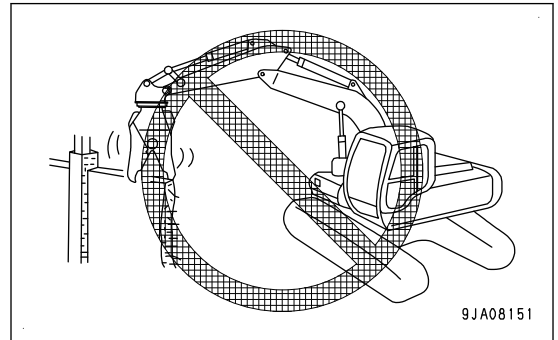

Do not drop or stop the breaker sharply.

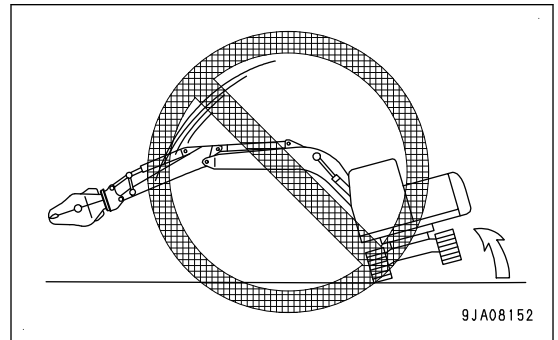

Do not perform work where broken pieces fall onto the machine.

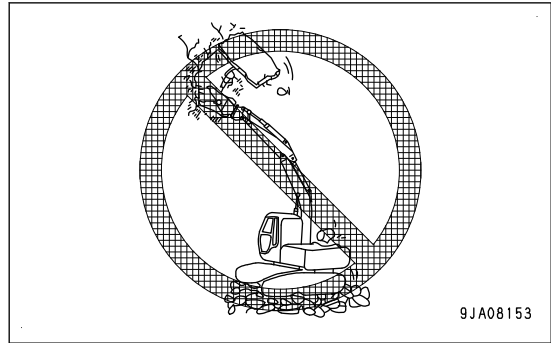

Do not work on a ground which cannot bear the machine weight or breaking impacts.

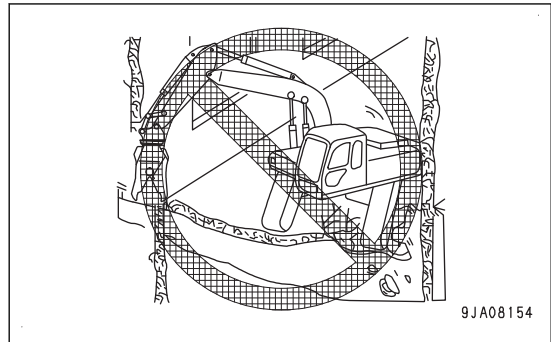

Do not perform work near the undercarriage of the machine.

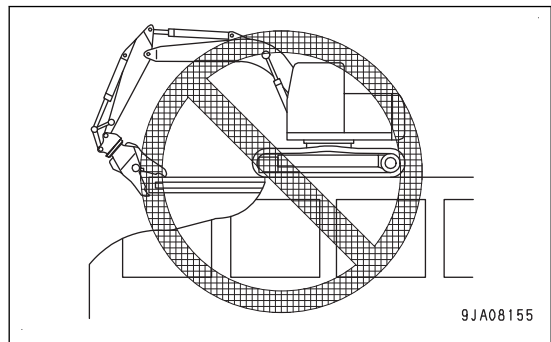

Do not work while the machine is inclined on debris, etc.

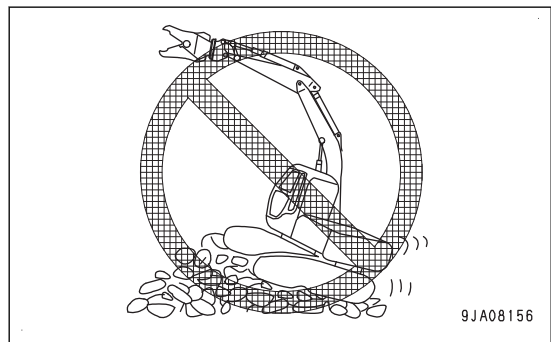

Do not work by using the swing force or dropping force.

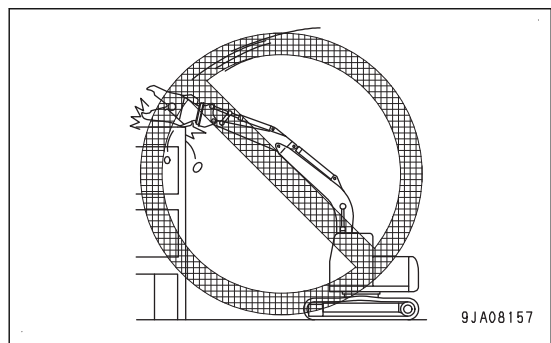

Always face the material to be broken at right angles.
 If the breaker bites into the material diagonally, an excessive force is applied to it and the machine is damaged.

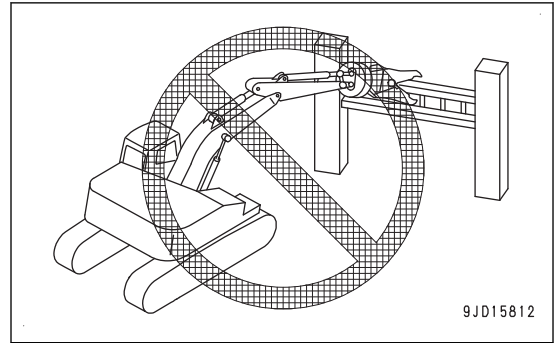

Do not extend the bucket cylinder or arm cylinder sharply.

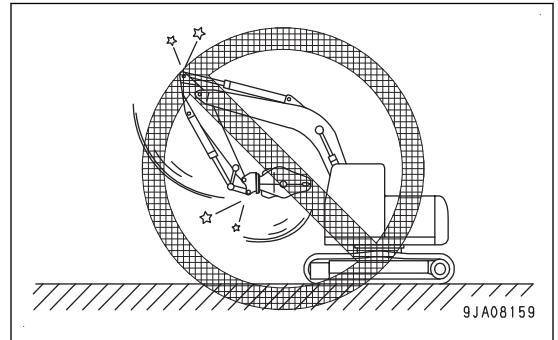

Do not raise the boom sharply.

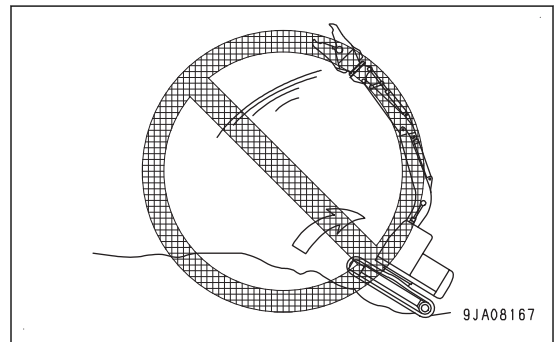

REPLACEMENT PARTS

PERIODIC REPLACEMENT OF DEFINED LIFE PARTS

For using the machine safely for an extended period of time, you must periodically replace the safety critical and fire prevention-related parts listed in the table of the defined life parts.

Material quality of these parts can change as time passes and they are likely to wear out or deteriorate. However, it is difficult to determine the extent of wear or deterioration at the time of periodic maintenance. Hence, it is required to replace them with new ones regardless of their condition after a certain period of usage. This is important to ensure that these parts maintain their full performance at all times.

Furthermore, should anything abnormal be found on any of these parts, replace it with a new one even if the periodic replacement time for the part has not yet arrived.

If any of the hose clamps show deterioration like deformation or cracking, replace the clamps at the same time as the hoses.

Also perform the following checks with hydraulic hoses which need not to be replaced periodically. Tighten all loose hoses and replace defective hoses, as required.

When replacing hoses, always replace O-rings, gaskets, and other such parts at the same time.

Have your Komatsu distributor replace the defined life parts.

DEFINED LIFE PARTS LIST

No.	Periodical replacement parts		Replacement interval
1	Fuel system	Fuel hose Spill hose	Every 2 years or 4000 hours, whichever comes sooner
2	Engine lubrication system	Engine oil filter hose	
3	Work equipment hydraulic system	Main pump delivery hose Pump delivery hose	
		Pump branch hose Main pump LS hose	
4	Others	External work equipment hose <ul style="list-style-type: none"> • Boom foot connection hose • Boom cylinder hose • Arm connection hose • Line hose for additional attachment 	
		PPC accumulator	
		Seat belt	Every 3 years from start of usage or 5 years after manufacturing of seat belt, whichever comes sooner.

CONSUMABLE PARTS

Replace consumable parts such as the filter element or air cleaner element at the time of periodic maintenance or before they reach the wear limit. The consumable parts should be replaced correctly in order to ensure more economic use of the machine. When replacing parts, Komatsu recommends using Komatsu genuine parts.

As a result of our continuous efforts to improve product quality, the part number may change. Inform your Komatsu distributor of the machine serial number and check the latest part number when ordering parts.

CONSUMABLE PARTS LIST

The parts in parentheses are to be replaced at the same time.

Item	Part No.	Part Name	Q'ty	Replacement interval
Engine oil filter	YM129150-35153	Cartridge	1	Every 500 hours
Fuel prefilter	YM129A00-55730 (YM129A00-55740)	Element (O-ring)	1 (1)	
Fuel main filter	YM129A00-55800	Cartridge	1	
Hydraulic tank breather	421-60-35170	Element	1	
Hydraulic oil filter	22P-60-21161 (07000-12135)	Element (O-ring)	1 (1)	Every 1000 hours
Hydraulic tank strainer	07000-12110	O-ring	1	Every 2000 hours
Air cleaner				-
• Outer element	3EB-02-63210	Element	1	
• Inner element	YM119005-12571		1	
Bucket	Vertical pin type			
	20T-70-72320	Tooth	4	
	(20T-70-71950)	(Pin)	(4)	
	(20T-70-71960)	(Lock)	(4)	
	20U-70-13241	Cutter (left)	1	
	20U-70-13251	Cutter (right)	1	
	(20U-70-28130)	(Bolt)	(8)	
	(203-32-51220)	(Nut)	(8)	

RECOMMENDED FUEL, COOLANT, AND LUBRICANT

NOTICE

- **Komatsu genuine oils are conditioned to maintain the reliability and durability of Komatsu construction equipment and components.**
In order to keep your machine in the best condition for long period of time, it is essential to follow the instructions in this Operation and Maintenance Manual.
- **Failure to follow these recommendations may result in shortened life or excessive wear of the engine, power train, cooling system, and/or other components.**
- **Commercially available lubricant additives may be good or bad for the machine. Komatsu does not recommend any commercially available lubricant additive.**
- **Komatsu recommends using Komatsu genuine engine oil for KDPF. If engine oil other than Komatsu genuine oil for KDPF is used, it may shorten cleaning interval of KDPF filters, adversely affect the engine such as deteriorated oil may reduce lubricating function, and it may cause failure, shortening of the machine life, lowering of performance and increase of fuel consumption.**
- **Use the oil according to the ambient temperature as recommended in the chart below.**
- **If the machine is operated at a temperature of -20 °C or lower {-4 °F or lower} , separate devices are needed, so consult your Komatsu distributor.**

NOTICE

The fuel used must be ultra low-sulfur diesel fuel.

To ensure good fuel consumption characteristics and exhaust gas characteristics, the engine mounted on this machine uses an electronically controlled high-pressure fuel injection device and emission gas control system (KDPF). Since the high-pressure fuel injection device requires high precision parts and lubrication, if low viscosity fuel with low lubricating ability is used, its durability may drop considerably. And using fuel with high sulfur content can deteriorate the engine parts and KDPF catalyzer, inducing failures, decrease of the life and degradation in performance. The ASTM diesel fuel recommended by Komatsu may contain 5 % or less of biofuel. The EN diesel fuel may contain 7 % or less of it. Use the fuel which is filled into the storage tank or the fuel tank of the machine as soon as possible.

When the diesel fuel is changed to the one mixed with the bio-fuel, replace the fuel prefilter element and the fuel main filter cartridge with new ones.

The use of metallic fuel additives is strictly prohibited.

Metallic components in the additives will not be burnt during the KDPF regeneration, and may cause abnormal conditions in the exhaust gas aftertreatment devices.

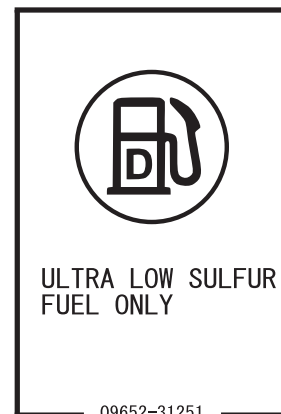





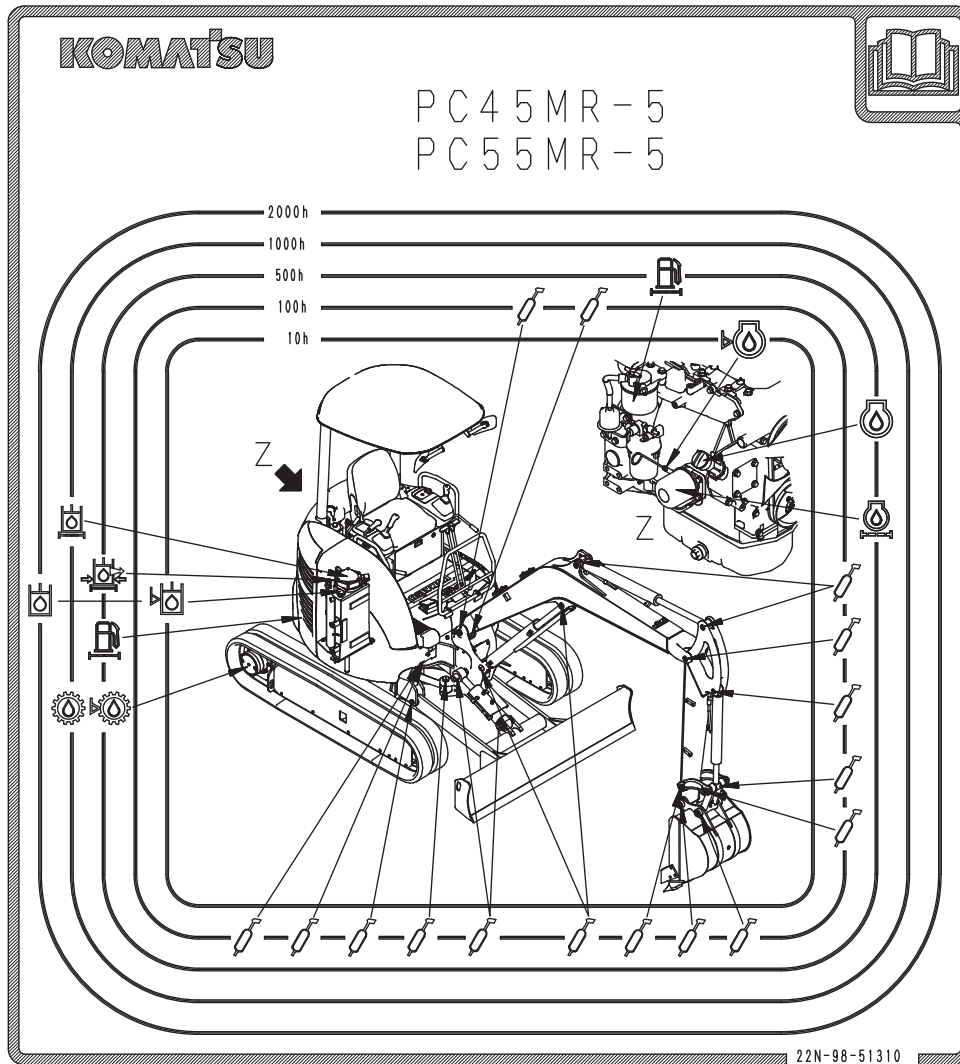







LUBRICATION CHART

- The lubrication chart uses symbols to show the lubrication points and types of lubricant by each lubrication interval.
- Even if the same symbol is used in the lubrication chart, the recommended genuine oil may differ according to the lubrication points and the ambient temperature.



9JD15393

The symbols used in the lubrication chart are explained in the following table.

Symbol	Meaning of the symbol	Symbol	Meaning of the symbol
	Read the Operation and Maintenance Manual.		Supply grease
	Change engine oil		Check oil level in engine oil pan
	Change hydraulic oil		Check hydraulic oil level
	Change power train oil		Check power train oil level
	Change engine oil filter		Change hydraulic oil filter
	Change breather element in hydraulic tank		Change fuel filter

METHOD FOR USING FUEL, COOLANT AND LUBRICANTS ACCORDING TO AMBIENT TEMPERATURE

Reservoir	Fluid type	Recommended Komatsu Fluids	Ambient temperature			
			°C		°F	
			Min	Max	Min	Max
Engine oil pan	Engine oil	EO10W30-LA (KES Diesel Engine Oil)	-20	40	-4	104
		EO15W40-LA (KES Diesel Engine Oil)	-15	50	5	122
		EO30-DH (KES Diesel Engine Oil)	0	40	32	104
Final drive case	Power train oil	TO30 (KES)	-30	50	-22	122
Hydraulic system	Hydraulic oil	HO56-HE (KES)	-20	50	-4	122
		HO46-HM (KES)	-10	50	14	122
	Power train oil	TO10 (KES)	-10	50	14	122
Grease fitting	Hyper grease (Note.1)	G2-TE (KES)	-20	50	-4	122
	Lithium EP grease	G2-LI (KES)	-10	50	14	122
Cooling system	Non-Amine Engine Coolant (AF-NAC) (Note.2)	AF-NAC (KES)	-30	50	-22	122
Fuel tank	Diesel fuel	ASTM D975 No.1-D S15	-30	20	-22	68
		ASTM D975 No.2-D S15	0	50	32	122

ASTM: American Society of Testing and Material

	Specified capacity		Refill capacity	
	ℓ	U.S.Gal	ℓ	U.S.Gal
Engine oil pan	8.1	2.14	7.5	1.98
Final drive case (each of right and left)	0.7	0.18	0.7	0.18
Hydraulic oil system	55	14.5	20	5.28
Cooling system	8.8	2.32	-	-
Fuel tank	65	17.2	-	-

REMARK

Specified capacity means the total amount of fluid including the fluid in the tank and the piping. Refill capacity means the amount of fluid needed to refill the system during inspection and maintenance.

Note 1: Hyper grease (G2-TE) has high performance.

When it is necessary to improve the lubricating performance of the grease in order to prevent squeaking of pins and bushings, the use of G2-TE is recommended.

Note 2: Non-Amine Engine Coolant (AF-NAC)

- The coolant has the important function of preventing corrosion as well as preventing freezing. Even in the areas where freezing is not an issue, the use of coolant is essential. Komatsu machines are supplied with Non-Amine Engine Coolant (AF-NAC). Non-Amine Engine Coolant (AF-NAC) has excellent anti-corrosion, antifreeze and cooling properties and can be used continuously for 2 years or 4000 hours. Non-Amine Engine Coolant (AF-NAC) is strongly recommended wherever available.
- The concentration of Non-Amine Engine Coolant (AF-NAC) is as shown in the following table.

Coolant density table

Min. atmospheric temperature	°C	-10 or more	-15	-20	-25	-30	-35	-40	-45	-50
	°F	14 or more	5	-4	-13	-22	-31	-40	-49	-58
Density (%)		30	36	41	46	50	54	58	61	64

The supplied Non-Amine Engine Coolant (AF-NAC) is already diluted.

In this case, fill up the tank with pre-diluted fluid. (Never dilute the Non-Amine Engine Coolant with ordinary water.)

RECOMMENDED BRANDS AND QUALITIES OTHER THAN KOMATSU GENUINE OILS

When using commercially available oils other than Komatsu genuine oil, consult your Komatsu distributor.

INDEX

Symbols

12H24H display mode - Switch.....3-70

A

Accumulator - Check function.....4-94
 Accumulator - Function.....4-93
 Accumulator for control circuit - Check / Release nitrogen gas pressure.....4-93
 Accumulator for control circuit - Replace.....4-100
 Action level display.....3-18
 Actions if fire occurs.....2-16
 Actions when running out of fuel.....3-234
 Adjust breaker oil flow rate.....6-12
 Adjust oil flow rate of general attachment such as crusher etc.....6-15
 After cold weather season.....3-231
 After finishing work - Check.....3-199
 Aftertreatment devices regeneration.....3-62
 Aftertreatment devices regeneration disable - Cancel.....3-128
 Aftertreatment devices regeneration disable - Set.....3-125
 Aftertreatment devices regeneration disable pilot lamp.....3-30
 Aftertreatment devices regeneration pilot lamp.....3-30
 Air cleaner - Check.....4-16
 Air cleaner - Check / Clean / Replace.....4-16
 Air cleaner element - Replace.....4-23
 Air cleaner element (double element) - Replace.....4-25
 Air cleaner element (single element) - Replace.....4-23
 Air cleaner outer element - Clean.....4-17
 Air cleaner outer element (double element) - Clean.....4-20
 Air cleaner outer element (single element) - Clean.....4-17
 Air conditioner - Check / Maintain.....4-52
 Air conditioner - Handle.....3-210
 Air conditioner - Operate.....3-212
 Air conditioner - Stop.....3-213
 Air conditioner compressor belt - Check / Adjust tension.....4-67
 Air conditioner fresh air filter - Clean.....4-79
 Air conditioner recirculation air filter - Clean.....4-68
 Air conditioner switch.....3-212
 Air flow selector switch.....3-211
 Air suspension seat - Adjust.....3-151
 Alternator and starting motor - Check.....4-97
 Always use clean washer fluid.....4-2
 Antenna - Stow.....6-29
 Appoint leader when working with others.....2-39
 Ashtray.....3-100
 Attachment - Bleed air.....4-61
 Attachment - Install.....6-33
 Attachment - Operate.....6-12

Attachment - Set.....3-56
 Attachment 1 proportional switch.....6-8
 Attachment control pedal.....6-7
 Attachment lock cover.....6-7
 Attachments and options.....6-33
 Auto idle stop timer - Set.....3-59
 Auto-deceleration function.....3-39
 Auto-deceleration pilot lamp.....3-26
 AUX.....6-26
 Avoid mixing oil.....4-3

B

Backhoe work.....3-193
 Band/AUX selector button.....6-24
 Basic operation of machine monitor.....3-10
 Battery.....3-230
 Battery - Check electrolyte level from side.....4-32
 Battery - Check electrolyte level impossible from side.....4-33
 Battery - Handle.....2-43
 Battery - Install.....3-240
 Battery - Remove.....3-239
 Battery - Remove / Install.....3-239
 Battery disconnect switch.....6-19
 Battery electrolyte - Check level.....4-31
 Beware of asbestos dust.....2-25
 Blade control lever.....3-90
 Boom swing control pedal.....3-90
 Boom swing cylinder foot pin - Lubricate.....4-54
 Breaker - Check points when using.....6-12
 Breaker - Operate.....6-13
 Breaker - Set.....3-53
 Breaker of machines equipped with attachment control pedal - Operate.....6-13
 Breaker of machines with proportional lever - Operate.....6-14
 Breaker operation switch.....6-8
 Breakers.....6-39
 Bucket - Replace.....3-195
 Bucket teeth - Replace.....4-48
 Buzzer cancel function.....3-41

C

Cab door.....3-98
 Cab door handle.....3-98
 Cab floor - Clean.....4-56
 Cab front window - Open / Close.....3-94
 Calendar - Set.....3-68
 Caution lamp list.....3-18
 Charge level caution lamp.....3-23
 Check and maintenance items.....4-52
 Check drained oil and used filter.....4-2
 Check service meter reading.....4-2
 Check signs and signalman's signals.....2-25

Checks after inspection and maintenance.....	4-4
Checks and adjustment before starting engine.....	2-26,3-131
Checks before starting.....	2-28,4-63
Clock - Adjust.....	3-66,6-29
Cold weather operation.....	3-229
Cold weather operation information.....	3-229
Comparison of road liners, rubber shoes and steel shoes.....	3-214
Consumable parts.....	7-3
Consumable parts list.....	7-3
Contents of safety labels.....	2-6
Control levers and pedals.....	3-86
Control patterns - Change.....	6-31
Control patterns other than standard control method (For machines equipped with operation pattern change-over valve).....	6-30
Controls and gauges names.....	3-4
Controls and gauges names - Cab specification....	3-5
Controls and gauges names: Canopy spec.....	3-4
Coolant.....	3-229
Coolant - Check level / Add.....	3-142
Coolant and water for dilution.....	4-6
Cooling cover - Close.....	3-204
Cooling cover - Open.....	3-203
Cooling cover - Opening / Closing.....	3-203
Cooling system - Clean inside.....	4-27
Counter-rotation turn - Operate.....	3-177
Cover with lock.....	3-200
Crankcase breather - Check.....	4-88
Cup holder.....	3-100
Cup holder: Cab spec.....	3-100
Cup holder: Canopy spec.....	3-100
Current abnormality list display.....	3-20
Cylinder - Bleed air.....	4-59

D

Daylight saving time - Set.....	3-71
Defined life parts list.....	4-99,7-2
Digging work.....	3-193
Directions of machine.....	1-4
Dirt cover - Lock.....	3-206
Dirt cover - Open.....	3-205
Dirt cover - Open / Close.....	3-205
Display.....	6-25
Display selector button.....	6-25
Display setting - Change.....	3-48
Display warning tag during inspection and maintenance.....	2-39
Display/non-display of ECO gauge - Switch.....	3-51
Ditching work.....	3-193
Do not disassemble recoil spring.....	2-47
Do not drop things inside machine.....	4-2
Do not get caught in work equipment.....	2-19
Do not go close to high-voltage cables.....	2-24
Do not perform lifting operations.....	3-186
Do not travel long time continuously.....	3-187

Dust indicator - Check.....	3-135
Dusty jobsite.....	4-3

E

ECO gauge.....	3-36
ECO gauge - Set target fuel consumption value..	3-52
Electric wiring - Check.....	3-145
Electrical components - Handle.....	4-9
Electrolyte level - Check when it is possible to use indicator.....	4-33
Emergency escape hammer.....	3-97
Emergency exit from operator's cab.....	2-19
Engine - Check low-speed run and acceleration	3-161
Engine - Check starting condition and unusual noise..	3-161
Engine - Operate / Check after starting.....	3-161
Engine - Operate / Check before starting.....	3-156
Engine - Start.....	3-158,3-243
Engine - Start with jumper cables.....	3-242
Engine - Stop.....	3-169
Engine - Warm-up operation.....	3-163
Engine coolant temperature caution lamp.....	3-20
Engine coolant temperature gauge.....	3-32
Engine oil pan - Change oil / Engine oil filter cartridge - Replace.....	4-69
Engine oil pan - Check oil level / Add oil.....	3-144
Engine oil pressure caution lamp.....	3-23
Engine rear cover - Lock.....	3-202
Engine rear cover - Opening / Closing.....	3-201
Engine rear cover - Opening procedure.....	3-201
Engine related parts - Phenomena and actions..	3-246
Engine shutdown secondary switch.....	3-85
Engine system caution lamp.....	3-23
Engine valve clearance - Check / Adjust.....	4-87
Ensure good visibility.....	2-24
Ensuring safe operation.....	2-13
Every 10 hours maintenance (only for first 100 hours)	4-15
Every 100 hours maintenance.....	4-64
Every 1000 hours maintenance.....	4-85
Every 1500 hours maintenance.....	4-88
Every 2000 hours maintenance.....	4-89
Every 250 hours maintenance.....	4-67
Every 3000 hours maintenance.....	4-98
Every 4000 hours maintenance.....	4-99
Every 500 hours maintenance.....	4-69
Every 6000 hours maintenance.....	4-101
Explanation of air conditioner equipment.....	3-210
Explanation of components.....	3-9
Explanation of components on machines with attachment.....	6-5
Explanation of components on machines with attachment control pedal.....	6-5
Explanation of components on machines with proportional lever.....	6-6
Explanation of heater components.....	6-22
Explanation of machine monitor equipment.....	3-9

Explanation of radio equipment..... 6-24

F

Fan belt - Check tension / Replace..... 4-83
 Filter..... 4-9
 Final drive case - Change oil..... 4-87
 Final drive case - Check oil level / Add oil..... 4-82
 Floor - Cab specification - Close..... 3-110
 Floor - Cab specification - Open..... 3-106
 Floor - Canopy specification - Close..... 3-108
 Floor - Canopy specification - Open..... 3-103
 Floor - Close..... 3-108
 Floor - Fix securely..... 4-4
 Floor - Open..... 3-103
 Floor - Open / Close..... 3-101
 Floor lock release lever..... 3-91
 Floor tilt fixing bolt - Cab specification - Check... 3-150
 Floor tilt fixing bolt - Canopy specification - Check.....
 3-148
 Floor tilt fixing bolt - Check..... 3-148
 Frequency - Adjust..... 6-27
 Frequency - Auto-preset..... 6-27
 Fresh and clean lubricants..... 4-2
 FRESH/RECIRC air changeover lever..... 3-211
 Fuel..... 4-6
 Fuel - Check level / Add..... 3-146
 Fuel and lubricants..... 3-229
 Fuel and lubricants to match the ambient temperature
 4-4
 Fuel circuit - Bleed air..... 3-234
 Fuel consumption gauge..... 3-35
 Fuel consumption gauge - Set display..... 3-49
 Fuel consumption record - Check..... 3-46
 Fuel control dial..... 3-79
 Fuel gauge..... 3-33
 Fuel injection system - Check / Clean..... 4-98
 Fuel level caution lamp..... 3-21
 Fuel main filter cartridge - Replace..... 4-74
 Fuel prefilter cartridge - Replace..... 4-71
 Fuel prefilter element - Clean..... 4-34
 Fuel tank - Drain water and sediment..... 3-133
 Fuel, coolant and lubricants according to ambient
 temperature - Use..... 7-7
 Function switches..... 3-39
 Function switches and guidance icons..... 3-37
 Fuse..... 3-113
 Fusible link..... 3-115

G

Gas spring - Check..... 4-57
 Gauge display..... 3-32
 General attachment such as crusher etc - Operate.....
 6-16
 General attachment such as crusher etc of machines
 with attachment control pedal - Operate..... 6-16

General attachment such as crusher etc of machines
 with proportional lever - Operate..... 6-17
 General attachment such as crusher, etc. - Check
 points when using..... 6-15
 General precautions common to operation and main-
 tenance..... 2-13
 General view..... 3-2
 GPS synchronization - Set..... 3-67
 Grease..... 4-7
 Grease pump holder..... 3-116
 Ground whole the bottom side of blade to support
 machine..... 3-187

H

Handle oil, fuel, coolant, and performing oil clinic... 4-5
 Handling bucket with hook..... 6-4
 Handrails and tracks - Use when getting on or off ma-
 chine..... 2-18
 Heater - Handle..... 6-22
 Heater - Use..... 6-23
 Heater switch..... 6-22
 High register range (treble) - Adjust..... 6-28
 High-pressure hoses and pipings - Handle..... 2-46
 Horn - Check..... 3-147
 Horn switch..... 3-80,6-8
 Hydraulic breaker..... 6-34
 Hydraulic circuit - Bleed air..... 4-3,4-58
 Hydraulic circuit - Release internal pressure..... 4-96
 Hydraulic circuit for machine ready for installation of
 attachment - Change-over..... 6-11
 Hydraulic circuit for machine ready for installation of
 attachment - Change-over / Connect..... 6-9
 Hydraulic circuit for machine ready for installation of
 attachment - Connect..... 6-9
 Hydraulic components - Handle..... 4-10
 Hydraulic oil filter element - Replace..... 4-85
 Hydraulic system - Warm-up operation..... 3-165
 Hydraulic system caution lamp..... 3-21
 Hydraulic tank - Change oil / Clean strainer..... 4-89
 Hydraulic tank - Check oil level / Add oil..... 3-138
 Hydraulic tank breather element - Replace..... 4-80

I

If any problem is found..... 2-15
 If machine monitor shows warning display..... 3-248
 Inside operator's compartment..... 2-14
 Inspecting machine..... 2-14
 Introduction..... 1-4
 Investigate and confirm jobsite conditions..... 2-23

J

Jumper cable - Connect..... 3-242
 Jumper cable - Disconnect..... 3-243

K

KDPF - Clean.....	4-101
KDPF soot accumulation caution lamp.....	3-22
KDPF system caution lamp.....	3-22
Keep machine clean.....	2-14
Komatsu Diesel Particulate Filter (KDPF) - Handle.....	3-117
Komatsu genuine lubricants.....	4-2
Komatsu genuine replacement parts.....	4-2
KOMTRAX.....	3-130

L

Lamp switch.....	3-80
Language - Set.....	3-72
Left front mirror - Adjust.....	3-153
Leveling work.....	3-194
Lifting operation by using bucket with hook.....	2-38
Loading and unloading with trailer.....	3-220
Loading work.....	3-194
Location of engine number plate.....	1-5
Location of product identification number (PIN)/ machine serial No. plate.....	1-5
Location of safety labels.....	2-3
Location of safety labels - Cab specification.....	2-4
Location of safety labels: Canopy spec.....	2-3
Lock.....	3-199
Lock inspection cover.....	4-3
Lock lever.....	3-87
Lock lever automatic lock cancel pilot lamp.....	3-31
Lock lever automatic lock cancel switch.....	3-84
Lock lever pilot lamp.....	3-31
Low register range (bass) - Adjust.....	6-28
Lubrication chart.....	7-5

M

Machine - Change direction during straight travel.....	3-177
Machine - Check walk-around.....	3-131
Machine - Escape from mud.....	3-192
Machine - Escape when track on one side is stuck.....	3-192
Machine - Escape when tracks on both sides are stuck.....	3-192
Machine - Lift.....	3-226
Machine - Load.....	3-221
Machine - Long-term storage.....	6-18
Machine - Lubricate.....	4-64
Machine - Operate to change direction during stop.....	3-176
Machine - Operate when working mode is not in ATT/P or ATT/E for attachment.....	6-15
Machine - Operate when working mode is not in breaker mode.....	6-12
Machine - Park.....	3-197
Machine - Running-in the new machine.....	3-162
Machine - Secure.....	3-223

Machine - Start (Travel forward and reverse) / Stop.....	3-170
Machine - Steer (Change the direction).....	3-176
Machine - Stop.....	3-175
Machine - Swing.....	3-178
Machine - Travel forward.....	3-171
Machine - Travel reverse.....	3-173
Machine - Unload.....	3-224
Machine equipment name.....	3-2
Machine monitor - Basic operation when stopping en- gine in normal situation.....	3-11
Machine monitor - Basic operation when trouble oc- curs while operating machine.....	3-15
Machine monitor - Operate when starting engine in abnormal situation.....	3-12
Machine monitor - Operate when starting engine in normal situation.....	3-10
Machine monitor - Operate when starting engine while engine shutdown secondary switch is ON...	3-10
Machine monitor equipment name.....	3-6
Machine operations and controls.....	3-131
Machine ready for installation of attachment.....	6-5
Machine settings.....	3-53
Main use of machine.....	1-4
Maintenance during long-term storage.....	3-233
Maintenance interval for hydraulic breaker.....	4-14
Maintenance of air conditioner.....	2-48
Maintenance procedure.....	4-15
Maintenance schedule.....	4-13
Maintenance schedule table.....	4-13
Maintenance screen - Set.....	3-63
Maintenance time caution lamp.....	3-24
Manual stationary regeneration - Operate.....	3-121
Message - Check.....	3-75
Message - Reply.....	3-76
Message display.....	3-29,3-73
Method for adjusting.....	3-151
Method for checking before starting.....	3-133
Method for steering machine.....	3-176
Mirrors - Adjustment.....	3-152
Mirrors: Cab spec - Adjust.....	3-153
Mirrors: Canopy spec - Adjust.....	3-152
Monitor settings.....	3-65
Monitor switches.....	3-37

N

No jumping on or off machine.....	2-18
No people on attachments.....	2-18

O

Oil.....	4-5
Only authorized personnel.....	2-39
Open knob for cab door.....	3-98
Open lock for cab door.....	3-99
Operating record - Check.....	3-45

Operator cab door - Lock..... 3-209
 Operator cab door - Open / Close..... 3-207
 Operator's cab door - Open..... 3-207
 Operator's seat - Adjust..... 3-151
 Other equipment..... 3-94
 Other equipment name..... 3-7
 Other equipment name - Cab specification..... 3-8
 Other equipment name: Canopy spec..... 3-7
 Other trouble..... 3-244,6-18
 Outline of maintenance..... 4-5

P

Perform KOWA (Komatsu Oil Wear Analysis)..... 4-8
 Periodic replacement of defined life parts..... 2-49
 Permissible depth of water, soil and dirt..... 3-189
 Phenomena and actions for chassis..... 3-245
 Phenomena and actions for electrical system.....
 3-244,6-18
 Phenomena that are not failures..... 3-236
 Pilot display..... 3-26
 Pilot display and gauge display..... 3-25
 Power button..... 6-24
 Power supply for KOMTRAX..... 3-130
 Power supply outlet..... 3-112
 Precautions after daily work completion in cold
 weather..... 3-231
 Precautions before starting inspection and mainte-
 nance..... 2-39
 Precautions before starting operation..... 2-13
 Precautions for blade position during backhoe opera-
 tion..... 3-189
 Precautions for charging battery..... 3-241
 Precautions for check and maintenance..... 2-43
 Precautions for cold weather..... 2-27
 Precautions for compressed air..... 2-48
 Precautions for discharged battery..... 3-238
 Precautions for disposing of waste materials..... 2-48
 Precautions for folding work equipment..... 3-188
 Precautions for getting on or off machine..... 2-18
 Precautions for high voltage..... 2-46
 Precautions for high-pressure fuel..... 2-46
 Precautions for high-pressure grease when adjusting
 track tension..... 2-47
 Precautions for high-pressure oil..... 2-46
 Precautions for high-speed travel..... 3-188
 Precautions for high-temperature coolant..... 2-45
 Precautions for high-temperature oil..... 2-45
 Precautions for high-temperature parts..... 2-45
 Precautions for hitting blade against objects during
 operating blade..... 3-188
 Precautions for installing, removing, or storing attach-
 ments..... 2-42
 Precautions for jobsite..... 2-23
 Precautions for KDPF..... 4-2
 Precautions for lifting operations..... 2-38,6-4
 Precautions for loading and unloading with trailer.....
 3-220

Precautions for long-term storage..... 3-232
 Precautions for maintenance..... 2-39,4-2
 Precautions for noise..... 2-47
 Precautions for opening and closing cooling cover..... 4-3
 Precautions for opening and closing covers..... 3-189
 Precautions for opening and closing floor..... 2-41
 Precautions for operation..... 2-23,2-28,3-188,6-4
 Precautions for refilling oil or fuel..... 4-2
 Precautions for severe job condition..... 3-237
 Precautions for towing and being towed..... 2-37
 Precautions for towing machine..... 3-237
 Precautions for transportation..... 2-36
 Precautions for transporting machine..... 3-219
 Precautions for traveling..... 3-188
 Precautions for traveling on slopes..... 2-31
 Precautions for using..... 6-3
 Precautions for using attachment and options..... 6-2
 Precautions for welding..... 2-43,4-2
 Precautions for working on slopes..... 3-190
 Precautions for working under machine or work
 equipment..... 2-42
 Precautions related to attachments and options... 2-21
 Precautions related to cab glass..... 2-21
 Precautions related to protective structure..... 2-20
 Precautions to prevent fire..... 2-16
 Precautions when installing hydraulic hoses..... 4-3
 Precautions when leaving machine..... 2-19
 Precautions when loading and unloading..... 2-36
 Precautions when operating on snow or frozen surfa-
 ces..... 2-35
 Precautions when parking machine..... 2-35
 Precautions when removing and installing..... 6-2
 Precautions when running engine inside building..... 2-22
 Precautions when selecting..... 6-2
 Precautions when standing up from operator's seat...
 2-19
 Precautions when starting engine..... 2-27
 Precautions when swinging boom..... 4-3
 Precautions when traveling..... 2-30
 Precautions when traveling in forward or reverse and
 swinging..... 2-29
 Precautions when using hammer..... 2-45
 Precautions when using rubber and road liners shoes
 3-216
 Precautions when working on loose ground..... 2-23
 Preheating pilot lamp..... 3-26
 Preparation for long-term storage..... 3-232
 Preparations for moving machine..... 3-170
 Preparations for safe operation..... 2-14
 Preset - Call up..... 6-27
 Preset - Register..... 6-28
 Preset button..... 6-25
 Prevent fire..... 2-16
 Product information..... 1-5
 Prohibited operations..... 2-33,3-183
 Prohibited operations when using rubber and road lin-
 ers shoes..... 3-215

Prohibition of digging operation at an angle without engaging teeth.....	3-185
Prohibition of digging operation on hard rocky ground.....	3-185
Prohibition of high-speed travel operations on rough ground.....	3-187
Prohibition of operations using bucket as lever..	3-184
Prohibition of operations using bucket dropping force.....	3-184
Prohibition of operations using hydraulic cylinders to stroke end.....	3-183
Prohibition of operations using machine dropping force.....	3-184
Prohibition of operations using swing force.....	3-183
Prohibition of operations using travel force.....	3-183
Prohibition of operations when machine is not stable.....	3-185
Prohibition of sudden lever or pedal shift during high speed travel.....	3-186
Prohibition of swinging or traveling when rock is on top of track assembly.....	3-186
Protection against falling, flying or intruding objects....	2-21
Protective structures.....	1-4
Provide fire extinguisher and first aid kit.....	2-15
Pump - Bleed air.....	4-58
Pump secondary drive switch.....	3-83

R

Radiator fin / Oil cooler fin / Fuel cooler fin / Condenser fin - Check / Clean.....	4-77
Radio - Control.....	6-27
Radio - Handle.....	6-24
Read the operation and maintenance manual thoroughly.....	6-2
Read this manual.....	1-2
Rear right mirror - Adjust.....	3-154
Recommended applications.....	3-193
Recommended attachment operations.....	6-34
Recommended brands and qualities other than Komatsu genuine oils.....	7-8
Recommended fuel, coolant, and lubricant.....	7-4
Recommended use of rubber and road liners shoes.....	3-214
Refrigerant (gas) for air conditioner - Check level	4-53
Replace defined life parts.....	4-99
Right front mirror - Adjust.....	3-154
Road liner - Check.....	4-41
Road liner - Replace.....	4-41
Road liner shoe bolt - Check looseness / Tighten	4-38
Room lamp switch.....	3-82
Rubber shoes - Check.....	4-42
Rubber shoes - Check / Adjust track tension.....	4-43
Rubber shoes - Check track tension.....	4-43
Rubber shoes - Decrease / Adjust track tension...	4-44
Rubber shoes - Increase / Adjust track tension....	4-44
Rubber shoes - Install.....	4-47

Rubber shoes - Remove.....	4-46
Rubber shoes - Replace.....	4-45
Rubber shoes and road liners - Handle.....	3-214

S

Safety information.....	1-3
Safety labels.....	2-2
Safety-related equipment.....	2-14
Screen adjustment.....	3-65
Seat - Adjust in fore-and-aft direction.....	3-151
Seat - Recline.....	3-151
Seat belt - Fasten.....	3-155
Seat belt - Fasten / Unfasten.....	3-155
Seat belt - Unfasten.....	3-155
Seat belt caution lamp.....	3-24
Select suitable place for inspection and maintenance.....	2-39
Selector valve.....	6-7
Service meter / Clock.....	3-34
Service meter location.....	1-6
Shoes - Change.....	4-47
Side ditching work.....	3-193
Slide window.....	3-97
Sound balance - Adjust.....	6-28
Sound control button.....	6-25
Specifications.....	5-2,6-18
Specifications - PC45MR-5.....	5-2
Specifications - PC55MR-5.....	5-4
Standard tightening torque for bolts and nuts.....	4-11
Start engine.....	2-26
Start engine with jumper cables.....	2-27
Start the machine after long-term storage.....	3-233
Starting switch.....	3-79
Steel shoes and road liners - Check / Adjust track tension.....	4-39
Steel shoes and road liners - Check track tension	4-39
Steel shoes and road liners - Decrease / Adjust track tension.....	4-40
Steel shoes and road liners - Increase / Adjust track tension.....	4-39
Steel track shoe bolt - Check looseness / Tighten	4-37
Stop engine before performing inspection and maintenance.....	2-40
Store oil and fuel.....	4-9
Swing lock cover.....	3-90
Swing pinion - Check grease level / Add grease..	4-62
Swing system - Lubricate.....	4-64
Switches.....	3-77
Switches - Cab specification.....	3-78
Switches: Canopy spec.....	3-77
System caution lamp.....	3-21
System operating lamp.....	6-21

T

Temperature control switch.....	3-211
Time - Set.....	3-69

Toolbox.....	3-116
Towing and being towed.....	2-37
Transportation.....	3-219
Transportation method - Select.....	3-219
Travel lever.....	3-89
Travel speed display.....	3-28
Travel speed selector switch.....	3-81
Troubles and actions.....	3-234
Tuning/time adjustment button.....	6-24
Two workers for maintenance when engine is running	2-41

U

Unauthorized modification.....	2-21
Understanding the machine.....	2-13
Upper cab front window - Close.....	3-96
Upper cab front window - Open.....	3-94
Use proper tools.....	2-42
Use warning tags.....	2-26
User menu.....	3-42

V

Vacuator valve - Check / Replace.....	4-26
Vent.....	3-211
Volume control button.....	6-24

W

Warning display.....	3-17
Warranty of rubber and road liners shoes.....	3-214
Washable floor - Wash.....	4-56
Water separator - Check / Drain water and sediment..	3-136
Wear well-fitting clothes and protective equipment.....	2-14
When handling accumulator and gas spring.....	2-48
When operating on slopes.....	2-32
When required.....	4-16
Window washer fluid - Check level / Add.....	4-51
Window washer fluid - select.....	2-48
Wiper switch.....	3-82
Work equipment - Lubricate.....	4-65
Work equipment - Operate.....	3-179
Work equipment control lever.....	3-92
Work place - Clean / Tidy.....	2-39
Working mode - Display.....	3-26
Working mode - Handle.....	3-182
Working mode - Operate.....	3-182
Working mode - Select.....	3-40
Working Record.....	3-45

Y

Your machine serial numbers and distributor.....	1-6
--	-----

PC45MR-5, PC55MR-5 HYDRAULIC EXCAVATOR

Form No. TEN00763-04

©2018 KOMATSU
All Rights Reserved
Printed in Japan 02-2018
