



Small to Medium Site Prep Jobs

Large Trench Compaction

Utility and Repair Work

High Centrifugal Force Outputs

Superior Traction

Variety of Drum Configurations

Advanced Shock Isolation

The SAKAI SV201-1

The SAKAI SV201-1 Series Vibratory Single Drum Compactors are designed for a variety of small to medium projects such as large trenches, site preparation and utility work. The SV201-1 Series offer a number of standard features found on SAKAI's larger single drum rollers such as a high compaction force, superior traction, unique hitch design, patented shock isolation system, superior serviceability, ROPS and seatbelts as well as a two brake, three-way failsafe braking system and a comfortable operating station. SAKAI offers four different SV201-1 models to meet a variety of soil types and application requirements.

SV201D-1 Smooth drum roller with drum and axle drives is well suited for use on sand, gravel and semi-cohesive soils.

SV201T-1 Padfoot drum roller with drum and axle drives for use on clays, silts and cohesive soils.

SV201TB-1 Padfoot drum roller with added strike-off blade is perfect for backfilling and leveling applications.

SV201TF-1 Offers a bolt-on smooth drum shell that mounts over the padfoot drum for quick drum switches to meet a variety of soil requirements.

| Model | | SV201D-1 | SV201T-1 | SV201TB-1 | SV201TF-1 |
|-------------------------------------|------------------|---|--------------|--------------------------------|-------------------------------|
| Drum | | Smooth | Padfoot | Padfoot W/ Strike-Off Blade | Smooth/Padfoot Combination |
| Operating Weight | lbs | 9,590 | 9,810 | 10,472 | 11,464 |
| | kg | 4,350 | 4,450 | 4,750 | 5,200 |
| On Front Axle | lbs | 4,740 | 4,960 | 5,732 | 6,614 |
| | kg | 2,150 | 2,250 | 2,600 | 3,000 |
| On Rear Axle | lbs | 4,850 | 4,850 | 4,740 | 4,850 |
| | kg | 2,200 | 2,200 | 2,150 | 2,200 |
| Vibration Frequency | VPM / Hz | 1,800 / 30 | | | |
| Centrifugal Force | lbs / kN | 16,100 / 72 | | | |
| Amplitude | in | 0.065 | 0.06 | 0.06 | 0.039 |
| | mm | 1.65 | 1.52 | 1.52 | 1 |
| Engine Make & Model Tier | | KUBOTA V3307 - TIER 3 | | | |
| Horsepower | hp / kW | 72.4 / 54.6 | | | |
| Maximum Speed | mph / kmh | 4.6 / 7.4 | | | |
| Gradability | percent | 59 | 55 | 50 | 44 |
| Fuel Tank Capacity | | 26 / 100 | | | |
| | gallons / liters | | | | |
| Braking Types | | Dynamic Hydrostatic, Wet Disc SAHR, Footbrake | | | |
| Outside Turning Radius | in / mm | 157 / 4000 | | | |
| Drum Diameter A | in / mm | 39 / 1000 | 41.9 / 1,050 | 41.9 / 1,050 | 43 / 1,090 |
| Drum Width B | in / mm | 54 / 1,370 | | | |
| Overall Length C | in / mm | 166 / 4,210 | 166 / 4,210 | 188 / 4,770 | 166 / 4,210 |
| Overall Width D | in / mm | 60 / 1,530 | 60 / 1,530 | 62 / 1,580 | 60 / 1,530 |
| Overall Height w/ROPS E | in / mm | 102 / 2,600 | 102 / 2,600 | 102 / 2,600 | 102 / 2,600 |
| Wheelbase F | in / mm | 92 / 2,330 | 92 / 2,330 | 92 / 2,330 | 92 / 2,330 |
| Curb Clearance G | in / mm | 11.8 / 300 | 12.4 / 315 | 12.4 / 315 | 13 / 330 |
| Side Overhang H | in / mm | 3.1 / 80 | 3.1 / 80 | 4.1 / 105 | 3.1 / 80 |

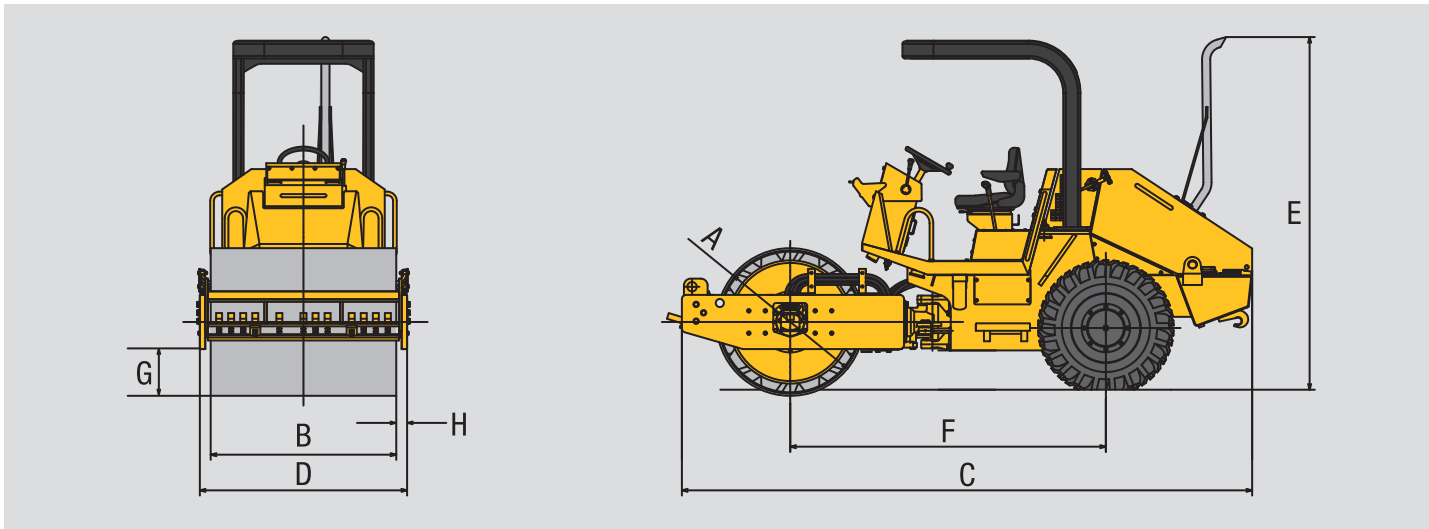

Your authorized Sakai dealer:



Sakai America Inc.
90 International Parkway, Adairsville, GA 30103
Tel 770-877-9433 or toll free 800-323-0535
Fax 770-877-9886 • www.sakaiamerica.com

SV201-1BROC1109

