



9KVa Generator

MKXD-9

-2x15A Outlets

-2x15A + 1x20A 3P Outlets



OPERATOR'S MANUAL

Table of Contents

INTRODUCTION	3
DISCLAIMER	3
ABOUT THIS MANUAL.....	4
KEY TERMS.....	4
PRODUCT INFORMATION	5
SAFETY INFORMATION	5
SAFETY DECALS	8
MKXD-9 WITH 2X15A + 1X20A 3P OUTLETS WITH RCBO PROTECTION.....	8
MKXD-9 WITH 2X15A OUTLETS WITH RCBO PROTECTION.....	8
PRODUCT SPECIFICATIONS	9
MKXD-9 WITH 2X15A + 1X20A 3P OUTLETS WITH RCBO PROTECTION.....	9
MKXD-9 WITH 2X15A OUTLETS WITH RCBO PROTECTION.....	10
ALTERNATOR SPECIFICATIONS	10
OVERALL MACHINE DIMENSIONS.....	11
FEATURES.....	11
OPERATION	12
BEFORE USE	12
OPERATING GENERATOR	14
STARTING THE ENGINE	14
BACKUP STARTING PROCEDURE.....	14
CONNECTING ELECTRICAL DEVICES	14
SHUTTING DOWN THE GENERATOR.....	14
MAINTENANCE	15
GENERAL RECOMMENDATIONS:	15
STORAGE.....	16
LIMITED WARRANTY	17
CONTACT INFORMATION	21
APPENDICES.....	22
APPENDIX A – GENERAL EXPLODED PARTS DIAGRAM	22
APPENDIX B- WIRING CIRCUIT DIAGRAM (2x15A).....	23
APPENDIX C- WIRING CIRCUIT DIAGRAM (2x15A + 1x20	24
APPENDIX D- RISK ASSESSMENT	25

INTRODUCTION

Thank you for purchasing a MAKINEX product.

This manual provides information and procedures to safely operate and maintain the *MKXD-9 Generator*. For your own safety and protection from injury, carefully read, understand and observe the safety instructions described in this manual.

Keep this manual or a copy of it with the machine. If you lose this manual or need an additional copy, please contact MAKINEX. This machine is designed and built with user safety in mind; however, it can present hazards if improperly operated and serviced. Please follow the operating instructions carefully. If there are any questions regarding operating or servicing of this machine, please contact MAKINEX.

All rights, especially copying and distribution rights are reserved.

Copyright 2014 by MAKINEX

No part of this publication may be reproduced in any form or by any means, electronic or mechanical, including photocopying, without express written permission from MAKINEX

Any type of reproduction or distribution not authorised MAKINEX represents an infringement of valid copyrights and will be persecuted. We expressly reserve the right to make technical modifications, even without due notice, which aim at improving our machines or their safety standards.

DISCLAIMER

MAKINEX and its affiliates take no responsibility for any damage, injury or death resulting from the incorrect or unsafe use of this product. Use of this product should be undertaken by competent persons only. It is the operator's responsibility to ensure that the following safety procedures are followed. If you are unsure, do not operate this product.

Record the model and serial numbers as well as date and place of purchase for future reference. Have this information available when ordering parts and when making technical or warranty inquiries

MAKINEX SUPPORT

+61 2 9460 8071

MODEL NO.

MKXD-9

SERIAL NO.

DATE OF PURCHASE

PURCHASE LOCATION

ABOUT THIS MANUAL

This manual uses the following symbols to help differentiate between different kinds of information. The safety symbol is used with a key word to alert you to potential hazards in operating and owning power equipment. Follow all safety messages to avoid or reduce the risk of serious injury or death.

KEY TERMS

 READ CAREFULLY	READ CAREFULLY – refers to <i>important information</i> that should be paid careful attention.
--	---

 CAUTION	CAUTION - indicates a potential hazardous situation which, if not avoided, <i>may</i> result in minor or moderate injury
---	---

 WARNING	WARNING – indicates a potentially hazardous situation which, if not avoided, <i>could</i> result in death or serious injury
---	--

 DANGER	DANGER – indicates a imminently hazardous situation which, if not avoided, <i>will</i> result in death or serious injury
--	---

 PROHIBITED	PROHIBITED – identifies actions that <i>should never</i> be carried out by anyone interacting with the machine.
--	--

PRODUCT INFORMATION

SAFETY INFORMATION



Read this manual **thoroughly** before operating your generator. Failure to follow instructions could result in serious injury or death



MAKINEX MKXD10 Generator designed for professional operators only, instruct operators in care and use of the machine before use!



GENERAL SAFETY PRECAUTIONS

- **ALWAYS** use in a well-ventilated area.
- **ALWAYS** ensure the applied load does not exceed the generators rating. Overloading the generator is dangerous and could cause serious damage.
- **ALWAYS** disconnect the generator when carrying out any maintenance.
- **ALWAYS** ensure the generator reaches operating speed before connecting a load.
- **ALWAYS** start the engine BEFORE connecting any appliances to the output receptacles.
- **ALWAYS** check the generator for damage before use.
- **ALWAYS** keep well clear of all moving parts on the generator at all times.
- **NEVER** allow children or animals near the generator.
- **NEVER** connect to a commercial or mains power supply, or any other electrical source.
- **NEVER** allow the generator to run out of fuel when a load is connected.
- **NEVER** alter or tamper with the internal wiring of the generator.
- **NEVER** climb or stand on the generator as dents may cause overheating of the acoustic lining.
- **NEVER** touch any part of the engine, alternator or exhaust when the generator is in use as these get hot and could burn.



RISK OF EXPLOSION OR FIRE

- Fuel and its vapours are extremely flammable and explosive
- Fire or explosion can cause severe burns or death

- **ALWAYS** switch the engine OFF when refuelling.
- **ALWAYS** refuel away from any source of heat.
- **ALWAYS** refuel in a well-ventilated area.
- **NEVER** overfill fill the tank, fill to the level specified.
- **NEVER** smoke whilst refuelling and avoid smoking or using a naked flame near the generator.
- **NEVER** start the engine if there is a fuel spill. Any spillage must be wiped clean and the generator allowed to dry before attempting to start the engine.



RISK OF BREATHING

- Running engine gives off Carbon Monoxide, an odourless, colourless, poisonous gas.
- Breathing Carbon Monoxide can cause nausea, fainting or death.
- Some chemicals or detergents may be harmful if inhaled or ingested, causing severe nausea, fainting or poisoning.

WARNING: EXHAUST FUMES CAN BE FATAL.

- **ALWAYS** ensure that there is adequate ventilation when using the generator.
- **ALWAYS** position the generator so that the exhaust is pointing away from people or animals.
- **NEVER** use the generator indoors or in an enclosed area. (i.e. in ware house, tunnel, well or a hold).

 WARNING	RISK OF ELECTRICAL SHOCK • Risk of electrocution.
---	---

- **ALWAYS** store the generator undercover when not in use and away from damp or wet conditions.
- **NEVER** use the generator outdoor when it is raining or snowing or in wet or damp conditions.
- **NEVER** use water or any other liquids to clean the unit while it is running.

 DANGER	RISK OF HOT SURFACES • Contact with hot surfaces, such as engines exhaust components, could result in serious burn.
--	---

- During operation, touch only the control surfaces of generator. Keep children away from the generator at all times. They may not be able to recognise the hazards of this product.

 WARNING	POSITIONING THE GENERATOR FOR USE
---	--

- **ALWAYS** leave at least a 1 metre gap between the generator and any surrounding building or structure.
- **ALWAYS** ensure the generator is on a solid, flat surface.
- **ALWAYS** ensure the surrounding area is free from any material that could burn or be damaged by heat.
- **NEVER** move or tilt the generator whilst it is switched on.
- **NEVER** cover or enclose the generator whilst it is in use.
- Be aware of the weight of the generator, do not attempt to lift or move the generator without the assistance of other personnel or suitable lifting equipment.

SAFETY DECALS

MKXD-9 WITH 2X15A + 1X20A 3P OUTLETS WITH RCBO PROTECTION

MAKINEX 9KVA GENERATOR MKXD-9

CAUTION

- Always use earth stake
- Never use in an enclosed area

ALTERNATOR ADVANTAGES

- AVR not necessary
- High efficiency (<92%)
- Good THD (<3%)
- No transients
- No voltage spike on load rejection

SPECIFICATIONS

Engine - 12 Hp Diesel
 Alternator - 8kW
 Outlets - 2 x 15 A Socket
 1 x 20A 3 Phase
 Fuel tank - 5L
 Start modes - E-start, Pull start
 Noise (7m) - 80dBA (50% load)

115kg

80dBA

makinex.com.au
 +61 2 9460 8071
 info@makinex.com.au
 Designed In Australia, Made In Australia

MKXD-9 WITH 2X15A OUTLETS WITH RCBO PROTECTION

MAKINEX 9KVA GENERATOR MKXD-9

CAUTION

- Always use earth stake
- Never use in an enclosed area

ALTERNATOR ADVANTAGES

- AVR not necessary
- High efficiency (<92%)
- Good THD (<3%)
- No transients
- No voltage spike on load rejection

SPECIFICATIONS

Engine - 12 Hp Diesel
 Alternator - 8kW
 Outlets - 2 x 15A Sockets
 Fuel tank - 5L
 Start modes - E-start, Pull start
 Noise (7m) - 80dBA (50% load)

115kg

80dBA

info@makinex.com.au
 +612 9460 8071
 makinex.com.au
 Designed In Australia, Made In Australia

PRODUCT SPECIFICATIONS



MKXD-9 WITH 2X15A + 1X20A 3P OUTLETS WITH RCBO PROTECTION

GENERATOR:	
MAX OUTPUT	9kVA
FREQUENCY	50Hz
VOLTAGE	240V
RATED OUTPUT	6200W
MAX OUTPUT	7600W
SOCKETS	2 X 15A SINGLE PHASE + 1 X 20A 3PHASE SOCKETS WITH RCBO PROTECTION
WEIGHT	122 kg
NOISE LEVEL (7M)	NO LOAD - 78dB
	50% LOAD - 80dB
	100% LOAD - 82dB
RATED POWER FACTOR	0.8
ENGINE:	
TYPE	SINGLE CYLINDER AIR COOLED DIESEL
MODEL	KOHLER KD500
STARTING SYSTEM	ELECTRIC/PULL START
DISPLACEMENT	505CC
NET. POWER	7.6 kW @ 3000 RPM
CONTINUOUS POWER	6.2 Kw @ 3000 RPM
FUEL ECONOMY	2.7 L/h @ 50% LOAD
FUEL TANK	5 L

MKXD-9 WITH 2X15A OUTLETS WITH RCBO PROTECTION

GENERATOR:	
MAX OUTPUT	9kVA
FREQUENCY	50Hz
VOLTAGE	240V
RATED OUTPUT	6200W
MAX OUTPUT	7600W
SOCKETS	2 X 15A SINGLE PHASE SOCKETS WITH RCBO PROTECTION
WEIGHT	122 kg
NOISE LEVEL (7M)	NO LOAD - 78dB
	50% LOAD - 80dB
	100% LOAD - 82dB
RATED POWER FACTOR	0.8
ENGINE:	
TYPE	SINGLE CYLINDER AIR COOLED DIESEL
MODEL	KOHLER KD500
STARTING SYSTEM	ELECTRIC/PULL START
DISPLACEMENT	505CC
NET. POWER	7.6 kW @ 3000 RPM
CONTINUOUS POWER	6.2 Kw @ 3000 RPM
FUEL ECONOMY	2.7 L/h @ 50% LOAD
FUEL TANK	5 L

ALTERNATOR SPECIFICATIONS

 RFL Alternators http://www.rflalternators.com			
Frame	132	Type	RF2 - 12.5
Enclosure	IP23	PM Brushless Alternator	
Poles	2	Phase	3
RPM	3000	Volts	415
Frequency	50 Hz	Amps	15.5
Power	10.0 kW	Motor Start k	14.0
Weight (kg)	40	Short Cir Amp	46.5
Ref Temp	27 °C	Serial No.	RF2-132-115-135-3P-1
 		EC. 1282. 0E140328. RFLQ093	

OVERALL MACHINE DIMENSIONS

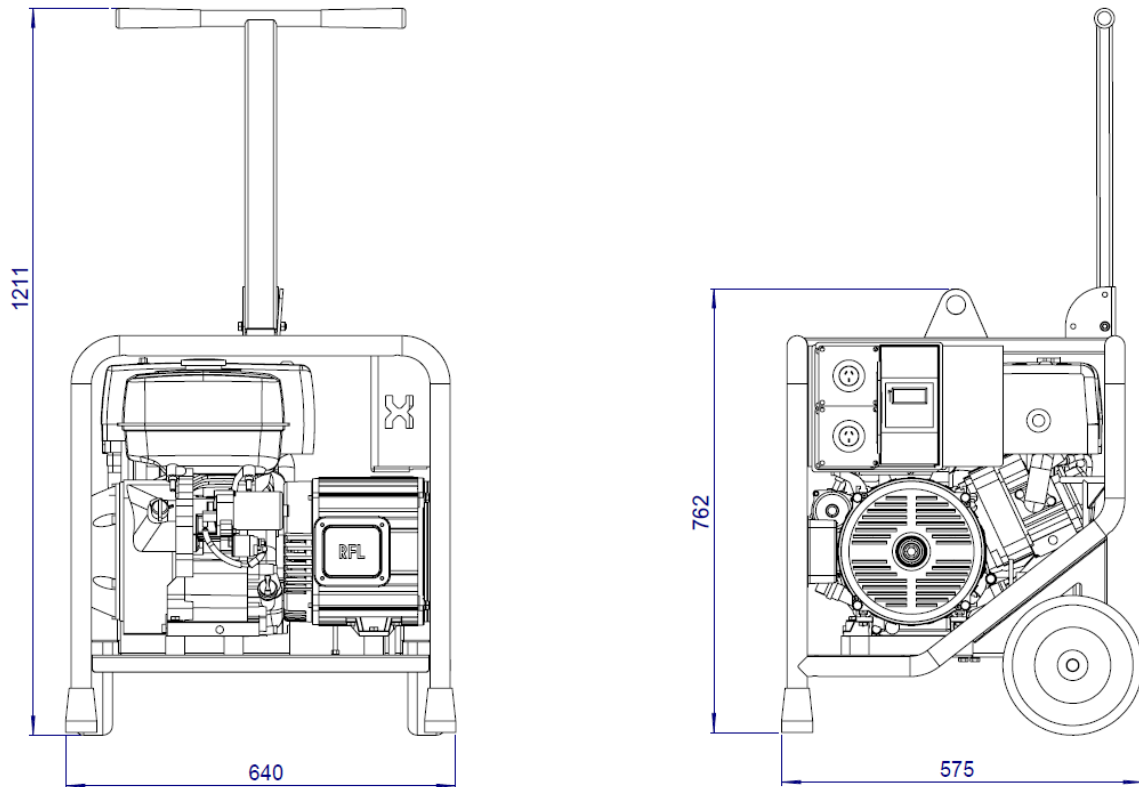

FEATURES

FEATURES
Durable Galvanised frame
Multi cushion isolators for vibration reduction
Compact design for easy storage and transport
Electric Start motor
Lifting point for transportation
RFL permanent magnet alternator

OPERATION

BEFORE USE

1. Add Engine Oil (New machines will be pre-oiled from MAKINEX)

- 1.1 Place generator on a flat, level surface.
- 1.2 Clean area around oil fill and remove oil fill cap.
- 1.3 Using oil funnel (optional), slowly pour contents into oil fill opening.
- 1.4 Replace oil fill cap and tighten.

NOTE: IMPROPER treatment of generator can damage it and shorten its life. DO NOT attempt to start the engine before it has been properly serviced with the recommended oil. This may result in an engine failure.

Adding Fuel



FAILURE TO USE FUEL AS RECOMMENDED IN THIS MANUAL WILL VOID WARRANTY

- DO NOT use GASOLINE.
- ONLY use DIESEL.**
- DO NOT modify engine to run on alternate fuels.



Fuel and fuel vapour are extremely flammable and explosive. Fire or explosion from misuse of fuel can cause severe burns and even death.

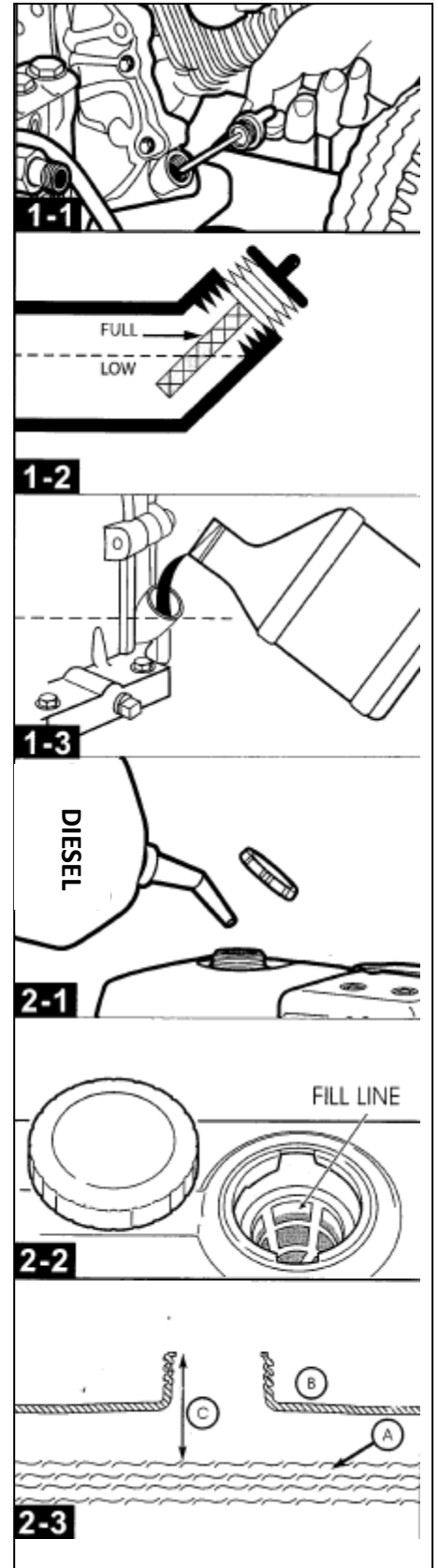

WHEN ADDING FUEL TO GENERATOR, OBSERVE THE FOLLOWING STEPS:

- 2.0 Always ensure that fuel tanks are filled outdoors.
- 2.1 Turn generator OFF and let it cool for at least two minutes before removing fuel cap.
- 2.2 Loosen fuel cap slowly to release pressure.
- 2.2 Slowly add DIESEL to fuel tank. DO NOT fill fuel above baffle. This allows appropriate space for fuel expansion.
- 2.3 Wait for spilled fuel to evaporate before starting the engine.
- 2.5 Keep fuel away from sparks, open flames, pilot lights, heat and other ignition sources.
- 2.6 DO NOT light a cigarette or smoke near open fuel tank or container.

OPERATING GENERATOR

STARTING THE ENGINE

1. Remove all connections from the AC sockets.
2. Open the fuel valve.
3. If you are starting the generator in low temperature conditions, close the choke lever fully. If not, open the choke lever fully.
4. Insert the key into the ignition.
5. Turn and hold the key in the START position.
6. Once the engine starts to run turn the key back to the ON position.
7. Gradually open the choke by turning the choke lever until it is in the fully open position.

BACKUP STARTING PROCEDURE

If for any reason the engine will not start using the above procedure, you can start your generator manually by carrying out the following.

1. Set the ignition key to the ON position.
2. Pull the starting handle lightly until you start to feel resistance and then pull up sharply to start the generator.
3. You may have to do this more than once.

CONNECTING ELECTRICAL DEVICES

The generator can supply 240V AC through 2 x 15amp or 240V AC through 2 x 15amp sockets and 415V AC through the 20A socket.

1. Connect the appliance to the generator starting with the device that draws the most current.
2. Set the circuit breaker to 'ON'.

SHUTTING DOWN THE GENERATOR

1. Disconnect all appliances connected to the generator.
2. Turn the ignition key to the OFF position.
3. Set the fuel supply valve to OFF.

NOTE: To stop the generator in an emergency, turn the ignition key to the off position.

MAINTENANCE

GENERAL RECOMMENDATIONS:

Regular maintenance will improve the performance and extend the life of the GENERATOR.

The generator's warranty does not cover items that have been subjected to operator abuse or negligence. To receive full value from the warranty, the operator must maintain the generator as instructed in this manual and in the engine manual, including proper storage.

NOTE: A vibration hour meter is installed on the machine to help with tracking operation hours.



Should you have questions about replacing components on your generator, please contact dealer for assistance.

STORAGE

Disconnect Battery

1. Disconnect the negative lead from the battery terminal and store cap screw and lock washer
2. Repeat for the positive battery lead.
3. Store the battery in a cool, dry place.

Charge the battery

For generator equipped with batteries for electric starting, proper battery maintenance and storage should be followed. An automatic battery charger with automatic trickle charging capability should be used to charge the battery. Maximum charging rate should not exceed 1.5amps. Follow the instructions included with the battery charger. The battery should be fully charged at least once per month.



Certain storage covers can be flammable or can melt in high temperatures. DO NOT place storage cover over generator until it has completely cooled.

LIMITED WARRANTY

In order to take advantage of the MAKINEX limited warranty, you must have maintenance performed according to the schedule (contained in relevant owner's manual supplied with this product), by an authorised MAKINEX dealer or MAKINEX service technician. You are free to have your MAKINEX product serviced by any suitably qualified mechanic or electrician (depending on the mechanical or electrical requirement) and this will not affect your statutory warranties, however, failure by the owner to have the recommended servicing carried out by an authorised MAKINEX dealer/service technician means that you cannot take advantage of the MAKINEX limited warranty.

In order to ensure your safety, we strongly recommend that you only use an authorised MAKINEX dealer for servicing. Only authorised MAKINEX dealers have access to all the special tools, technical information, parts and training required to maintain your MAKINEX product in peak operating condition.

MAKINEX warrants each new Generator to be free from defects in material and workmanship under normal domestic and industrial use and service for the period specified below, conditional to the limitations and exclusions printed on this page. This warranty applies only to new MAKINEX generator distributed by us and by our authorised MAKINEX dealers.

Our goods come with guarantees that cannot be excluded under the Australian Consumer Law. You are entitled to a replacement or refund for a major failure and compensation for any other reasonably foreseeable loss or damage. You are also entitled to have the goods repaired or replaced if the goods fail to be of acceptable quality and the failure does not amount to a major failure.

WARRANTY: (Ex-factory/ Reseller premise)

MAKINEX warrants to the original purchaser:

- Frame and Engine will be free of defects in material and workmanship for a period of one (1) year from the original date of purchase.
- Honda GX Engine is subject to (3) years warranty. Please see www.hondapowerequipment.com.au for details.
- Kohler KD Engine is subject to (3) years or 2000 hours warranty.
- 3 years warranty on RFL alternators

Warranty Exclusions

This warranty does not cover the following repairs and equipment:

Normal Wear

Generator need periodic parts and service to perform well. This warranty does not cover repair when normal use has exhausted the life of a part or the equipment as a whole.

Installation, Use and Maintenance

This warranty will not apply to parts and/or labour if this generator is deemed to have been misused, neglected, involved in an accident, abused, loaded beyond the generator's limits, modified, installed improperly. Normal maintenance such as spark plugs, air filters, adjustments, fuel system cleaning and obstruction due to build-up is not covered by this warranty.

Other Exclusions

This warranty excludes:

- Cosmetic defects such as paint, decals, etc.
- Wear items such as filter elements, Pistons, O-rings, etc.
- Accessory parts such as starting batteries, and storage covers.
- Failures due to acts of God and other force majeure events beyond the manufacturer's control.
- Problems cause by parts that are not original MAKINEX parts.

Responsibility of the consumer under this Limited Warranty:

- Strict adherence to the maintenance checks and schedule with proof of scheduled maintenance service required by an authorised agent or qualified mechanic.
- Maintenance services are not covered under warranty.
- It is the consumer's responsibility to deliver the machine in question to our service premises or to the premises of our appointed agent at the consumer's expense for replacement or repair as applicable.

Claim Procedure:

- Contact MAKINEX by phone or email informing us of your machines problem or defect.
- Once the extent of the claim has been assessed, we retain the right to compensate the consumer for such defect, or repair (parts & labour), or replace the machine under warranty.
- All warranties will be carried out by MAKINEX authorised staff or appointed agents at a premises to be determined by the Manufacturer.
- It is the responsibility (and cost) of MAKINEX or our appointed agent to return the machine to be repaired or replaced under warranty to the consumer- this is valid for domestic territories only (e.g. Australian units will be delivered within Australian territory, USA units will be delivered within USA territory and European units will be delivered within its designated country's territories).
- Where the specific warranty component (e.g. Engine) is under a Manufacturer's warranty other than MAKINEX (e.g. Honda, Subaru or Kohler etc.), the consumer can either contact MAKINEX or the applicable Manufacturer for repairs where such warranty was registered with that manufacturer at purchase.
- Warranty calls will only be carried out by our representatives and not via client's choice of repairer. We will not accept back charges for any work not carried out by our representatives, or accept any charges due to equipment being un-operational for any reason even during its warranty period.

WARRANTY CONTACT INFORMATION:

AUSTRALIA

Tel + 61 2 9460 8071

Fax +61 2 9439 9815

d.lobban@makinex.com.au

15 Waltham St, Artarmon, NSW

2064 AUSTRALIA

USA

Tel 407-446-1966

j.spencer@makinexusa.com

EUROPE

Tel +31 (0)6 24881203

+31 (0)6 50841849

SERVICE & PART ORDERING

For service and ordering parts, please call

AUS: 1300 795 953 or +61 2 9460 8071

USA: 407-446-1996

EUROPE: +31 (0)6 24881203 or +31 (0)6 50841849

Or your nearest MAKINEX distributor

We have very knowledgeable, experienced staff to assist you with help and advice.

CONTACT INFORMATION



**AUSTRALIA/ NEW ZEALAND
UNITED STATES OF AMERICA
EUROPE**

W makinex.com
E sales@makinex.com

APPENDICES

- APPENDIX A- GENERAL EXPLODED PARTS DIAGRAM
- APPENDIX B- WIRING CIRCUIT DIAGRAM (2x15A)
- APPENDIX C- WIRING CIRCUIT DIAGRAM (2x15A + 1x20A 3P)
- APPENDIX D- RISK ASSESSMENT

APPENDIX A – GENERAL EXPLODED PARTS DIAGRAM

DO NOT MEASURE FROM THIS DRAWING
IF IN DOUBT - ASK!

No.	TITLE	PART No.	QTY
1	FRAME ASSY	MKXD 01-00	1
2	SWITCH BOX BRACKET	MKXD 01-07	1
3	ALTERNATOR SPACER	MKXD 01-09	2
4	250MM WHEEL	MKXD 01-10	2
5	RUBBER FOOT	MKXD 01-11	2
6	ENGINE MOUNT	MKXD 01-12	4
7	BATTERY BAR	MKXD 01-15	1
8	BATTERY ROD	MKXD 01-16	2
9	IGNITION SWITCH BRACKET	MKXD 01-17	1
10	BATTERY RUBBER	MKXD-01-18	1
11	HANDLE	MKXD 02-00	1
12	HANDLE GRIP	MKXD 02-03	2
13	WHEEL AXLE	WHE 03-00	2
14	8 MODUL MOUNTING BOX	MKXD 05-01	1
15	15A POWER POINT	MKXD 05-02	2
16	W/P ENCLOSURE FRONT	MKXD 05-04	2
17	20A 3PHASE OUTLET + SWITCH	MKXD 05-09	1
18	EARTH SPIKE	HGEN 06-00	1
19	12V BATTERY	MKXD 07-00	1
20	RF2-132-100-135 ALT.	MKXD 08-00	1
21	HANDLE LOCK	HL-01	1

EXPLODED VIEW

ISOMETRIC VIEW

**MKXD-9 GENERATOR
EXPLODED PARTS LIST**

MAKINEX

Sydney (Head Office) Ph: 1300 795 953
15 Waltham St Fax: (02) 9439 9815
Artarmon, 2064 www.makinex.com.au
NSW, Australia sales@makinex.com.au

001

APPENDIX C- WIRING CIRCUIT DIAGRAM (2x15A + 1x20)

PRINT MAY BE REDUCED - DO NOT SCALE.

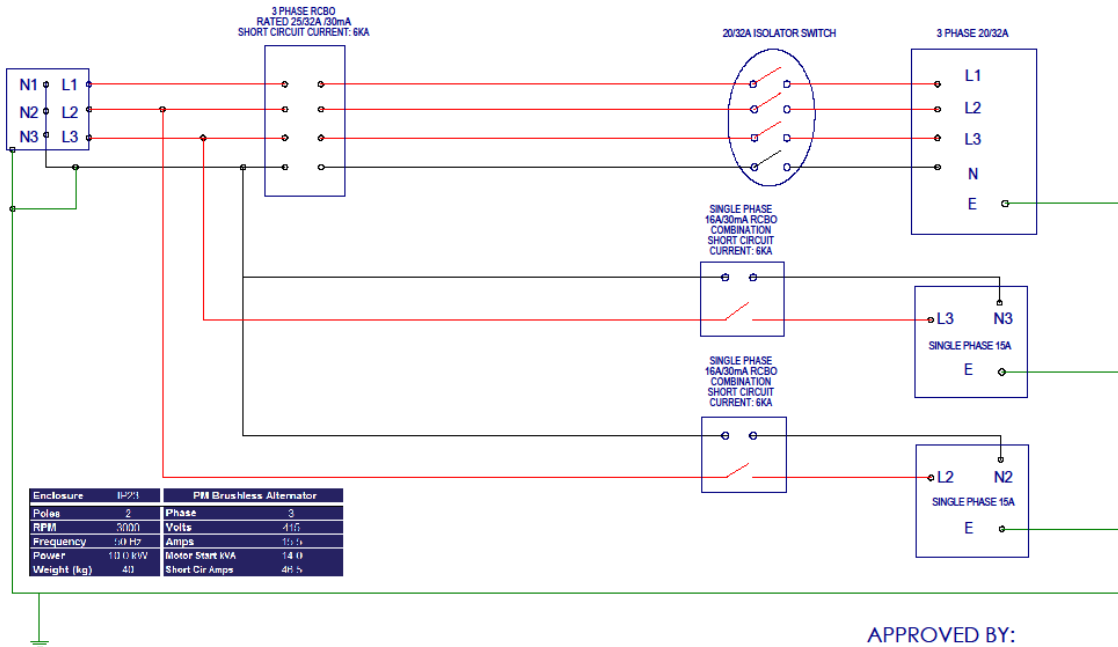

Enclosure	IP21	PM Brushless Alternator
Poles	2	Phase
RPM	3000	Volts
Frequency	50Hz	Amps
Power	10 (1) kW	Motor Start kVA
Weight (kg)	40	Short Cir Amps

APPROVED BY:

PRINT NAME: _____
SIGNATURE: _____

NOTE: Connection diagram for isolated generation only!

<p>Sydney (Head Office) Ph: 1300 795 953 15 Waltham St Fax: (02) 9439 9815 Artarmon, 2064 www.makinex.com.au NSW, Australia sales@makinex.com.au</p>	COPYRIGHT 2013 MAKINEX. WARNING: Copyright in this drawing remains the property of MAKINEX and copying in whole or part is not permitted without the written authority of the copyright owner.	DATE: 26/03/2015	PROJECT: MKX-10 and MKXD-9	DRN: T.B.		
	GENERAL TOLERANCES (Unless otherwise noted) 0-100mm: ± 0.25 mm 100mm - 500mm: ± 0.5 mm 500mm - ∞: ± 1.0 mm Angular: ± 1 deg.	SCALE: D.N.S A3 All Dimensions are in Millimetres Break All Sharp Corners and Remove Burrs & Swarf Third Angle Projection Default Critical Dimension	DWG NO.	TITLE 2x15A SINGLE + 20/32A CIRCUIT DIAGRAM	MATERIAL	FINISH
	NOTES:			MASS	REV	SHEET 1 OF 1

APPENDIX D- RISK ASSESSMENT

PRODUCT RISK / HAZARD ASSESSMENT TABLE

PRODUCT NAME:	MKXD-9 Generator	Assessment Carried Out By:	Thomas Barna
MANUFACTURER:	MAKINEX	Document Revision Number:	001
OPERATOR COMPETENCY:	PLANT LICENCE NOT REQUIRED	Date Created:	05/04/2014

No:	TYPE / NATURE OF RISK or HAZARD	LIKELIHOOD	CONSEQUENCE	RISK LEVEL	CONTROL ACTION					
1.0	BURNS/FIRE	1.1	PERSONAL INJURY – BURNS WHILST DOING MAINTENANCE ON MACHINE	2	LIKELY	4	NEGLIGIBLE	4	LOW	- BE CAUTIOUS OF HOT PARTS (SUCH AS MUFFLERS). ALLOW TO COOL BEFORE MAINTENANCE/ADJUSTMENTS
		1.2	FIRE/EXPLOSION WHILST REFUELING ENGINE	3	UNLIKELY	2	MAJOR	3	MEDIUM	- SHUT OFF MACHINE AND ALLOW TO COOL BEFORE REFUELING. NEVER REFUEL WHILE MOTOR IS RUNNING. - DO NOT SMOKE AND ENSURE REFUELING IS UNDERTAKEN IN WELL VENTILATED AREA (OUTSIDE, CLEAR OF IGNITION SOURCES)
2.0	ELECTROCUTION	2.1	LOW RISK OF POSSIBLE MINOR BURNS FROM MAINS ELECTRICAL CONNECTIONS ON GENERATOR	3	UNLIKELY	1	FATALITY	2	HIGH	- ENSURE THAT NO PART OF BODY IS IN CONTACT WITH TERMINALS WHEN STARTING / USING GENERATOR
3.0	ERGONOMIC INJURY	3.1	PERSONAL INJURY WHEN LIFTING/OR MOVEMENT ON SITE	2	LIKELY	2	MAJOR	2	HIGH	- STAFF TRAINING ON CORRECT LIFTING PROCEDURE
		3.2	STARTING PORTABLE GENERATOR	3	UNLIKELY	3	MINOR	4	LOW	- MANUAL HANDLING TRAINING
4.0	NOISE	4.1	HEARING DAMAGE DUE TO LONG TERM USE	3	UNLIKELY	3	MAJOR	4	MEDIUM	- ALWAYS WEAR HEARING PROTECTION WHILST OPERATING AND/OR IN CLOSE VICINITY OF THE MACHINE

NOTES:

- > THIS PRODUCT HAS BEEN DESIGNED AND MANUFACTURED AS A GENERATOR ONLY
 - > THIS DOCUMENT HAS BEEN PREPARED ACCORDING TO GUIDELINES AND RECOMMENDATIONS FOUND IN:
 1. 'HAZPAK' PRODUCED BY THE WORK-COVER AUTHORITY AND
 2. THE AUSTRALIAN STANDARDS 4024.1.4/5 - 1996
- "SAFEGUARDING OF MACHINERY - PART 1: GENERAL PRINCIPLES AUSTRALIAN STANDARD, AS/NZS 3760 IN-SERVICE SAFETY INSPECTION AND TESTING OF ELECTRICAL EQUIPMENT.

"LIKELIHOOD LEVEL" REFERS TO THE PROBABILITY OF AN EVENT HAPPENING. THE FOLLOWING SCALE HAS BEEN USED TO DESCRIBE THE LIKELIHOOD OF A DEFINED RISK / HAZARD EVENT OCCURRING DURING NORMAL OPERATION OF THE EQUIPMENT. NOTE THAT LIKELIHOOD EVALUATION IS QUALITATIVE AND BASED ON BEST ESTIMATION VIA CONSULTATION AND EXPERIENCE:

1. **VERY LIKELY**
2. **LIKELY**
3. **UNLIKELY**
4. **VERY UNLIKELY**

"CONSEQUENCE" REFERS TO THE SEVERITY OF INJURY CAUSED DUE TO AN EVENT OCCURRING, USING THE FOLLOWING SCALE AS DEFINED BY THE "HAZPAK" DOCUMENT:

1. **FATALITY** = INJURIES RESULT IN DEATH
2. **MAJOR** = NORMALLY IRREVERSIBLE INJURIES
3. **MINOR** = REVERSIBLE INJURIES REQUIRING SEVERAL DAYS OFF
4. **NEGLIGIBLE** = ABLE TO BE TREATED USING FIRST AID

"RISK LEVEL" REFERS TO THE SEVERITY OF A RISK BASED ON THE "LIKELIHOOD LEVEL" AND "INJURY LEVEL". INHERENTLY, AS THE CONSEQUENCE INCREASES IN SEVERITY, RISK INCREASES - EVEN WHEN LIKELIHOOD IS LOW - THE FOLLOWING SCALE HAS BEEN USED:

1. **HIGH** = POTENTIAL DEATH, PERMANENT DISABILITY, OR MAJOR STRUCTURAL DAMAGE.
2. **MEDIUM** = POTENTIAL TEMPORARY, DISABILITY, OR MINOR STRUCTURAL DAMAGE.
3. **LOW** = POTENTIAL INCIDENT THAT HAS THE POTENTIAL TO CAUSE PERSONS TO REQUIRE FIRST AID.