

Form No.  
908268/  
BP0904  
English

# **SL3635**

# **SL3935**

# **SKID-STEER**

# **LOADER**

**SL3635 SN 00001175 & LATER**  
**SL3935 SN 00001337 & LATER**



## **OPERATOR'S MANUAL**

**GEHL**<sup>®</sup>

**WRONG**



**Operators must have instructions before running the machine. Untrained operators can cause injury or death.**

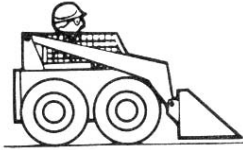

**Never use loader without ROPS/FOPS. Never modify the ROPS/FOPS structure.**



**Gehl, in cooperation with the American Society of Agricultural Engineers and the Society of Automotive Engineers, has adopted this Safety Alert Symbol to pinpoint precautions which, if not properly followed, can create a safety hazard. When you see this symbol in this manual or on the machine itself, you are reminded to BE ALERT! Your personal safety is involved!**

**WRONG**



**Never use the loader to lift personnel.**

**CORRECT**



**Read Operator's Manual before using machine.**

**WRONG**



**Do not use loader around explosive dust or gas, or where exhaust can contact flammable material.**

**CORRECT**

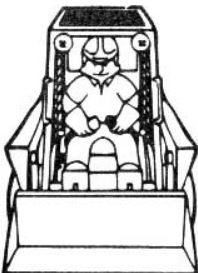

**Always fasten seatbelt snugly. Always keep feet on the floor/pedals when operating loader.**

# SL3635 and SL3935 Skid-Steer Loader Operator's Manual

## TABLE OF CONTENTS

Introduction . . . . .	1
<b>Safety . . . . .</b>	<b>6</b>
Controls and Safety Equipment . . . . .	16
Operation . . . . .	32
Service . . . . .	41
Troubleshooting . . . . .	56
Maintenance Schedule . . . . .	65
Specifications . . . . .	68
Table of Common Materials and Densities . . . . .	72
Index . . . . .	74
Torque Specifications . . . . .	76

<b>Loader Model Number</b>	
<b>Loader Serial Number</b>	
<b>Engine Serial Number</b>	

# INTRODUCTION

This Operator's Manual gives the owner/operator information about maintaining and servicing SL3635 and SL3935 skid steer loader models. More importantly, this manual provides an operating plan for safe and proper use of the machine. Major points of safe operation are detailed in the *Safety* chapter of this manual.

We ask that you read and understand the contents of this manual completely and become familiar with your new machine before operating it. See your authorized Gehl dealer if you have any questions concerning information in the manual, require extra manuals or for information concerning the availability of manuals in other languages.

Throughout this manual, information is provided which is set in *italic* type and introduced by the word Note or Important. Read carefully and comply with the message — it will improve your operating and maintenance efficiency, help avoid breakdowns and damage, and extend your machine's life.

A manual storage box in the operator's compartment holds the Operator's Manual and EMI Safety Manual. Please return the manuals to this box and keep them with the unit at all times. If this machine is resold, we recommend that these manuals be given to the new owner.

The attachments and equipment available for use with this machine have a wide variety of potential applications. Read the manual provided with the attachment to learn how to safely maintain and operate the equipment. Be sure the machine is suitably equipped for the type of work to be performed.

Do not use this machine for any applications or purposes other than those described in this manual or applicable for approved attachments. If the machine is to be used with special attachments or equipment other than those approved by Gehl Company, consult your Gehl dealer. Any person using non-approved attachments or making unauthorized modifications is responsible for the consequences.

The Gehl dealership network stands ready to provide you with any assistance you may require, including providing genuine Gehl service parts. All service parts should be obtained from your Gehl dealer. Give complete information about the part and include the model and serial numbers of your machine. Record these numbers in the space provided on the Table of Contents page, as a handy reference.







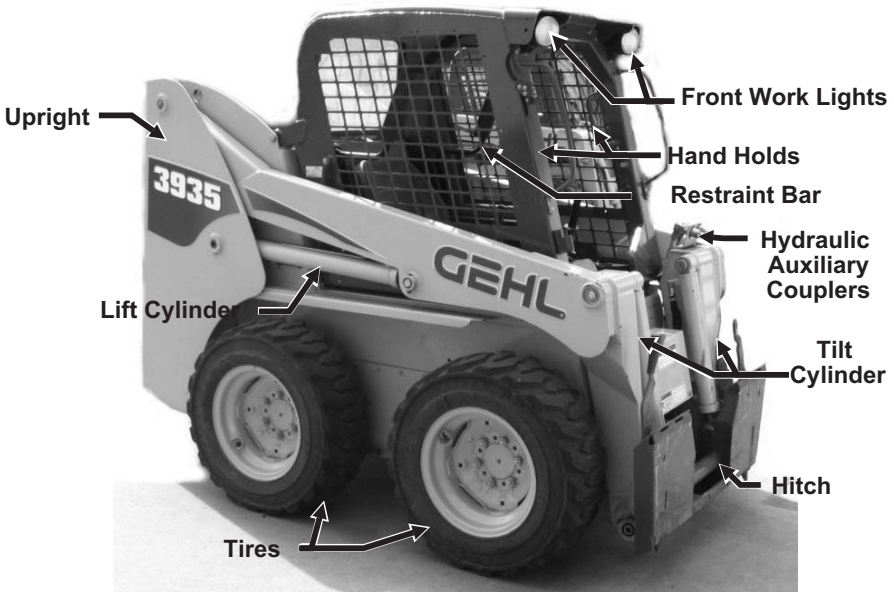































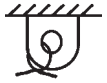

Please be aware that Gehl strives to continuously improve its products and reserves the right to make changes and improvements in the design and construction of any part without incurring the obligation to install such changes on any unit previously delivered.

If this machine was purchased “used,” or if the owner’s address has changed, please provide your Gehl dealer or Gehl Company Service Department with the owner’s name and current address, along with the machine model and serial number. This will allow the registered owner information to be updated, so that the owner can be notified directly in case of an important product issue, such as a safety update program.

## Model Identification



## Control/Indicator Symbols

 <b>Power Off</b>	 <b>Power On</b>	 <b>Engine Start</b>	 <b>Hazard Flasher</b>	 <b>Worklight</b>
 <b>Worklight w/Flasher</b>	 <b>Battery Charge</b>	 <b>Parking Brake</b>	 <b>Read Operator's Manual</b>	 <b>Horn</b>
 <b>Volume - Full</b>	 <b>Volume- Half Full</b>	 <b>Volume - Empty</b>	 <b>Pre-Heat</b>	 <b>Diesel Fuel</b>
 <b>Lift Point</b>	<b>N</b> <b>Neutral</b>	 <b>Safety Alert</b>	 <b>Chaincase Oil</b>	 <b>Seatbelt - Lap Only</b>
 <b>Engine Air Filter</b>	 <b>Engine Oil</b>	 <b>Engine Oil Filter</b>	 <b>Engine Oil Pressure</b>	 <b>Fuel Filter</b>
 <b>Engine Coolant Temperature</b>	 <b>Hydraulic System</b>	 <b>Hydraulic Oil Temperature</b>	 <b>Hydraulic Oil Filter</b>	 <b>Grease Lubrication Point</b>
 <b>Tie-Down</b>	 <b>Machine Travel - Forward</b>	 <b>Machine Travel - Reverse</b>	 <b>Clockwise Rotation</b>	 <b>Counterclockwise Rotation</b>
 <b>Fast</b>	 <b>Slow</b>	 <b>Bucket - Lower</b>	 <b>Bucket - Raise</b>	 <b>Bucket - Float</b>
 <b>Bucket - Rollback</b>	 <b>Bucket - Dump</b>			

# Notes



# SAFETY



This safety alert symbol means Attention! Become alert! Your safety is involved! It stresses an attitude of “Heads Up for Safety” and can be found throughout this Operator’s Manual and on the decals on the machine.

Before operating this machine, read and study the following safety information. In addition, be sure that everyone who operates or works with this machine, whether family member or employee, is familiar with these safety precautions. It is essential to have competent and careful operators, who are not physically or mentally impaired, and who are thoroughly trained in the safe operation of the machine and the handling of loads. It is recommended that the operator be capable of obtaining a valid motor vehicle operator’s license.

The use of skid steer loaders is subject to certain hazards that cannot be eliminated by mechanical means, but only by exercising intelligence, care and common sense. Such hazards include, but are not limited to, hillside operation, overloading, instability of the load, poor maintenance and using the equipment for a purpose for which it is not intended or designed.

Gehl ALWAYS considers the operator’s safety when designing its machinery and guards exposed moving parts for the operator’s protection. However, some areas cannot be guarded or shielded in order to assure proper operation. Furthermore, this Operator’s Manual and the decals on the machine warn of additional hazards and they should be read and observed closely.

Some photographs in this manual may show doors, guards and shields open or removed for illustrative purposes only. Be sure that all doors, guards and shields are in their proper operating positions before starting the engine to operate the unit.

Different applications may require optional safety equipment, such as a back-up alarm, horn, mirror, strobe light or an impact-resistant front door. Be sure you know the job site hazards and equip your machine as needed.



**DANGER** “DANGER” indicates an imminently hazardous situation which, if not avoided, will result in death or serious injury.



**WARNING** “WARNING” indicates a potentially hazardous situation which, if not avoided, could result in death or serious injury.

---



## **CAUTION**

**“CAUTION” indicates a potentially hazardous situation which, if not avoided may result in minor or moderate injury. May also alert against unsafe practices.**

---

### **Mandatory Safety Shutdown Procedure**

---

Before cleaning, adjusting, lubricating, servicing the unit or leaving it unattended:

1. Move the drive control handle(s) to the “neutral” position.
2. Lower the lift arm and attachment completely. If the lift arm *must* be left in the “raised” position, BE SURE to properly engage the lift arm support device (page 18).
3. Move the throttle to the low idle position, shut off the engine and remove the key.
4. Before exiting, move the lift/tilt control(s) to verify that the controls do not cause movement of the lift arm and hitch.

---

### **Safety Reminders**

---

#### **Before Starting**

- Do not modify the ROPS/FOPS unless instructed to do so in installation instructions. Modifications such as welding, drilling or cutting can weaken the structure and reduce the protection it provides. A damaged ROPS/FOPS cannot be repaired — it must be replaced.
- To ensure safe operation, replace damaged or worn-out parts with genuine Gehl service parts.
- Gehl skid steer loaders are designed and intended to be used only with Gehl attachments or approved referral attachments. Gehl cannot be responsible for operator safety if the loader is used with a non-approved attachment.
- Remove all trash and debris from the machine each day, especially in the engine compartment, to minimize the risk of fire.
- Always face the loader and use the hand holds and steps when getting on and off the loader. Do not jump off the loader.
- Never use starting fluid (ether).
- Walk around the machine and warn all nearby personnel before starting the machine.
- Always perform a daily inspection of the machine before using it. Look for damage, loose or missing parts, leaks, etc.

## During Operation

- The terrain, engine speed, load being carried and abrupt control movements can affect machine stability. IF MISUSED, ANY OF THE ABOVE FACTORS CAN CAUSE THE LOADER TO TIP, THROWING YOU FORWARD OR OUT OF THE UNIT, CAUSING DEATH OR SERIOUS INJURY. Therefore, always have the operator restraint bar lowered and wear the seatbelt. Operate the controls smoothly and gradually at an appropriate engine speed that matches the operating conditions.
- Always travel with the heavier end of the loader toward the top of the incline for additional stability when operating on inclines or ramps.
- Do not raise or drop a loaded bucket or fork suddenly. Abrupt movements under load can cause serious instability.
- Never push the lift control into the “float” position with the bucket or attachment loaded or raised, because this will cause the lift arm to lower rapidly.
- Do not drive too close to an excavation or ditch; be sure that the surrounding ground has adequate strength to support the weight of the loader and the load.
- Never carry riders. Do not allow others to ride on the machine or attachments, because they could fall or cause an accident.
- Always look to the rear before backing up the skid steer loader.
- Operate the controls only from the operator’s seat.
- Do not exceed the rated operating load of the machine.
- Always keep hands and feet inside the operator’s compartment while operating the machine.
- New operators must operate the loader in an open area away from bystanders. Practice with the controls until the loader can be operated safely and efficiently.
- Exhaust fumes can kill. Do not operate this machine in an enclosed area unless there is adequate ventilation.
- When you park the machine and before you leave the seat, check the restraint bar for proper operation. The restraint bar, when raised, applies the parking brake and deactivates the lift/tilt controls.

## Maintenance

- Never attempt to by-pass the keyswitch to start the engine. Use only the jump starting procedure detailed in the *Service* chapter of this manual.
- Never use your hands to search for hydraulic fluid leaks. Instead, use a piece of paper or cardboard. Escaping fluid under pressure can be invisible and can penetrate the skin and cause serious injury. If any fluid is injected into your skin, see a doctor at once. Injected fluid must be surgically removed by a doctor or gangrene may result.

- Always wear safety glasses with side shields when striking metal against metal. In addition, it is recommended that a softer (chip resistant) material be used to cushion the blow. Failure to heed could lead to serious injury to the eyes or other parts of the body.
- Do not smoke or have any spark producing equipment in the area while filling the fuel tank or while working on the fuel or hydraulic systems.

## **Potential Hazards**

---

A skid steer loader operator must ALWAYS be conscious of the working environment. Operator actions, the environmental conditions and the job at hand require the full attention of the operator so that safety precautions can be taken.

ALWAYS maintain a safe distance from electric power lines and avoid contact with any electrically charged conductor or gas line. Accidental contact or rupture can result in electrocution or an explosion. Contact the North American One Call Referral System at (888) 258-0808 for the local “Digger’s Hotline” number or the proper local authorities for utility line locations BEFORE starting to dig!

Exposure to crystalline silica (found in sand, soil and rocks) has been associated with silicosis, a debilitating and often fatal lung disease. A Hazard Review (Pub. No. 2002-129) by the U.S. National Institute for Occupational Safety and Health (NIOSH) indicates a significant risk of chronic silicosis for workers exposed to inhaled crystalline silica over a working lifetime. NIOSH recommends an exposure limit of 0.05 mg/m<sup>3</sup> as a time-weighted average for up to a 10-hr workday during a 40-hr workweek. NIOSH also recommends substituting less hazardous materials when feasible, using respiratory protection and regular medical examinations for exposed workers.

## **Safety Decals**

---

The skid steer loader has decals that provide safety information and precautions around the loader. These decals must be kept legible. If missing or illegible, they must be replaced promptly. Replacements may be obtained from your Gehl dealer. New equipment must have all decals specified by the manufacturer affixed to their proper place.

**Note:** *Contact your dealer for information concerning the availability of warning decals in other languages.*

## **New Decal Application**

Surfaces must be free of dirt, dust, grease and foreign material before applying the decal. Remove the smaller portion of the decal backing paper and apply the exposed adhesive to the clean surface, maintaining proper position and alignment. Peel the rest of the backing paper and apply hand pressure to smooth out the decal surface. Refer to the following pages for proper decal location. Text decals begin on page ; Non-text decals begin on page .

# Safety Decals inside the ROPS

## WARNING

**AVOID INJURY OR DEATH**

- Read Operator's Manual and all safety signs before using machine.
- The owner is responsible to ensure all users are instructed on safe use and maintenance.
- Check machine before operating. Service per Operators Manual.
- Contact dealer (or manufacturer) for information and service parts.

137628

137628 - Located on the manual box, operator's right



## WARNING

**AVOID INJURY OR DEATH**

Always follow "Mandatory Safety Shutdown Procedure".

<p>1</p>	<p>2</p>
<p>3</p>	<p>4</p>

1. Lower equipment to ground.
2. Reduce throttle, stop engine.
3. Apply park brake; remove key.
4. Check safety interlocks.

137683 - Located on ROPS left panel

## DANGER

**AVOID INJURY OR DEATH**

- Keep hands, feet and body inside cab when operating.
- Keep out from under lift arm unless lift arm is supported.
- Always follow "Mandatory Safety Shutdown Procedure."

137647 - Located on operator's lower left side

## WARNING

**AVOID OVERTURN**

- Carry load low. Wear seatbelt.
- Do not exceed Rated Operating Load.
- Avoid steep slopes and high speed turns.
- Travel up and down slopes with heavy end uphill.

137647

## WARNING

**AVOID INJURY OR DEATH**

- Maintain 3-point contact during entry and exit.
- Inspect work area, avoid all hazards.
- Look in direction of travel. Keep children and bystanders away.
- Start and operate machine only from seat.
- Never carry riders. Do not lift personnel in bucket.
- Operate only in well ventilated area.
- Keep away from electric power lines, avoid contact.
- Do not wear loose clothing while operating or servicing machine.
- Wear any needed Personal Protective Equipment.

137639

137639 - Located on ROPS left panel

# Safety Decals on the Outside of the Skid Loader



<b>! DANGER</b>		Hose removal or component failure can cause lift arm to drop.
		Always use lift arm support device when leaving lift arm raised for service.

137637 - Lift arm support device, loader left side



<b>! WARNING</b>	
	
	Be sure lock mechanism is securely engaged before working under ROPS/FOPS.
	Read instructions for use in Operator's Manual.

184214 - Under ROPS

<b>! DANGER</b>		
<b>AVOID INJURY OR DEATH</b>		
	<input type="checkbox"/> Keep out from under work tool, unless lift arm is supported. <input type="checkbox"/> No riders! Never use work tool as work platform.	

137655 - Front of loader

<b>! WARNING</b>	
	<b>AVOID INJURY OR DEATH</b> Before operating with attachment, check engagement of loader attachment bracket locking pin to the attachment.

137720 - Front of loader



# Safety Decals in the Engine Compartment

 <b>WARNING</b>	
<b>AVOID INJURY OR DEATH</b>	
<input type="checkbox"/> Keep safety devices working.	<input type="checkbox"/> Keep guards, screens and windows in place.
<input type="checkbox"/> Jump start per Operator's Manual procedure.	<input type="checkbox"/> Do not smoke while fueling or servicing machine.
<input type="checkbox"/> Clean debris from engine compartment daily to avoid fire. Keep fire extinguisher nearby.	
<input type="checkbox"/> Do not use hands to find hydraulic leaks. Escaping oil under pressure can be invisible and penetrate skin.	
<input type="checkbox"/> Allow radiator to cool before removing cap. Loosen cap slowly to avoid burns.	

137657

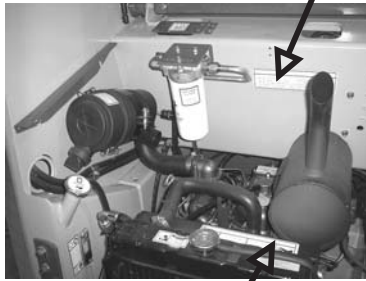
137657 - Right of hydraulic filter



 <b>WARNING</b>			
	<b>ROTATING FAN</b>  Keep hands out or stop engine.	<b>HOT SURFACE</b>  Do not touch hot engine or hydraulic system parts.	

137658

137658 - On radiator



## Product and Component Plate Location

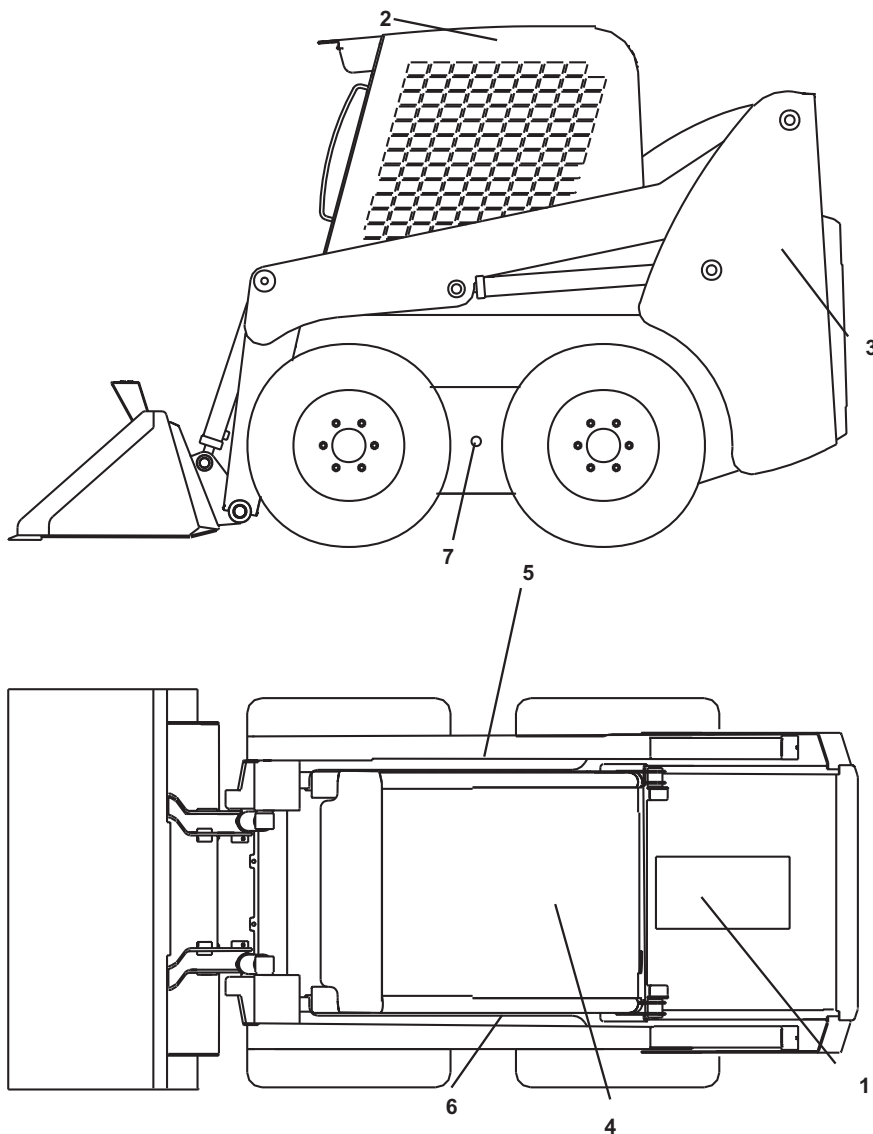

### Product and Component Plates

1. Engine plate: with e.g. type designation, product- and serial number
2. Operator protection system plate: with e.g. model, certification and operator protection system serial number
3. Product plate: with Product Identification Number and e.g. model/type designation
4. Seat plate according to ISO 7096
5. Component plate rear drive axle : with e.g. product- and serial number
6. Component plate front drive axle : with e.g. product- and serial number
7. Component plate transmission: with e.g. product- and serial number

# Notes

# CONTROLS and SAFETY EQUIPMENT



## **CAUTION**

Become familiar with and know how to use all safety devices and controls on the skid steer loader before operating it. Know how to stop loader operation before starting it. This Gehl loader is designed and intended to be used only with a Gehl attachment or a Gehl-approved referral attachment or accessory. Gehl cannot be responsible for operator safety if the loader is used with a non-approved attachment.

## **Guards and Shields**

Whenever possible and without affecting loader operation, guards and shields are provided to protect against potentially hazardous areas. In many places, safety decals are also provided to warn of potential hazards and/or to display special operating procedures.



## **WARNING**

Read and thoroughly understand all safety decals on the loader before operating it. Do not operate the loader unless all factory-installed guards and shields are properly secured in place.

## **Operator Restraint Bar**

Lower the restraint bar after entering the operator's compartment. The restraint bar is securely anchored to the ROPS. The restraint bar switch is wired in series with the seat switch forming an interlock for the lift arm, tilt, drive and starter circuits (refer to the "Safety Interlock System" topic on page 17 for more information).



## **WARNING**

Never defeat the operator restraint bar or seat switch electrically or mechanically. Always wear your seatbelt.



**Fig. 1: Operator's Seat**

1. Restraint Bar
2. Seatbelt
3. Seat Adjustment Lever
4. Suspension Seat Knob (optional)

## **Operator's Seat**

The seat is mounted on rails for backward or forward repositioning. A spring-loaded latch handle activates the seat adjustment mechanism.

Suspension seat (optional): A weight adjustment knob is provided with this seat for operator comfort.

## Safety Interlock System

---

---



**WARNING** NEVER defeat the safety interlock system by mechanically or electrically bypassing any switches, relays or solenoid valves.

---

---

An interlock system is used on the loader for operator safety. Together with solenoid valves, switches and relays, the interlock system:

- » Prevents the engine from starting unless the operator is sitting on the seat and the operator restraint bar is down.
- » Disables the lift arm, attachment tilt and wheel drives anytime the operator leaves the seat, turns the keyswitch to OFF or raises the restraint bar.
- » Disables the engagement of the auxiliary hydraulics anytime the restraint bar is raised or the keyswitch is OFF.

### **Testing the Safety Interlock System**

Before leaving a parked machine, check the safety interlock system for proper operation:

#### **Restraint Bar**

With the engine running, raise the restraint bar. Test each of the controls. There should be not more than a slight movement of the lift arm, hitch and machine. If there is any significant movement, troubleshoot and correct the problem immediately. Contact your dealer if necessary.

#### **Seat Switch**

With the engine off and the restraint bar lowered, unfasten your seatbelt. Lift your weight up off the seat. Try to start the engine. If the engine starts, turn off the engine, and troubleshoot and correct the problem. Contact your dealer if necessary.

## ROPS/FOPS

---

The ROPS/FOPS (Roll Over/Falling Object Protective Structure) is designed to provide protection for the operator from falling objects and in case the loader tips or rolls over, provided the operator is secured inside the ROPS by the seatbelt and restraint bar.



**WARNING**

**Never operate the loader with the ROPS removed or locked back.**

---

## Parking Brake

---

This skid loader is equipped with a spring-applied hydraulic-release parking brake. The parking brake engages when the operator lifts the restraint bar, leaves the operator's seat or shuts off the engine. The brake can also be applied manually by using the switch located on the right control panel of the ROPS. The red indicator on the switch lights when the parking brake is applied.



**Fig. 2: Parking Brake Switch**

## Horn

---

## Rear Window Emergency Exit

---

The ROPS rear window has three functions: noise reduction, falling objects barrier and emergency exit.

To use the emergency exit, pull on the yellow warning tag at the bottom of the window and remove the seal. Push out the window and exit.

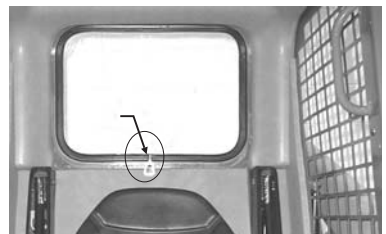

**Fig. 3: Rear Window Emergency Exit**

1. Pull Tag

## Lift Arm Support Device

---

The lift arm support device on the left lift cylinder is used as a cylinder lock to prevent the raised lift arm from unexpectedly lowering. Be sure to engage the support device when the lift arm is raised for service. When the support device is not being used, store it under the lift arm using the lock pin. The support device is a safety device that must be kept in proper operating condition at all times. The following steps ensure correct usage:

**⚠️ WARNING** The safest method of engaging the lift arm support device requires two people - one person inside the loader and another person to engage the support device.

---

**Note:** *With the keyswitch OFF and the solenoid valve working, the lift arm will stay raised when the lift control is moved to lower the lift arm. If the valve does not hold the lift arm and it begins to lower, do not leave the operator's compartment. Instead, have someone store the support device for you. Then, contact your Gehl dealer immediately to determine why the lift arm lowers while the keyswitch is OFF.*

### Engagement

---

**⚠️ WARNING** Always engage the lift arm support device before leaving the operator's compartment to work on the loader with the lift arm raised.

---

To engage the lift arm support device:

1. Lower the lift arm fully onto the loader frame.
2. Stop the engine.
3. Leave the operator's compartment. Remove the lock pin holding the support device up against the lift arm. Allow the support device to come down into contact with the lift cylinder.
4. Return to the operator's compartment and start the engine.
5. Raise the lift arm until the lift arm support device drops over the end of the lift cylinder and around the cylinder rod. Slowly lower the lift arm until the support device contacts the top end of the lift cylinder.
6. Be sure the support device is secure against the cylinder end. Then, stop the engine, remove the key and leave the operator's compartment.



**Fig. 4: Lift Arm Support Device Engaged**

## Disengagement

**WARNING** Never leave the operator's compartment to disengage the lift arm support device with the engine running.

To return the lift arm support device to its storage position:

1. Raise the lift arm completely.
2. Stop the engine, remove the key and take it with you.

**WARNING** Before testing the loader, always clear people from the area.

3. Before leaving the operator's compartment, be sure that the lift arm is being held in the raised position by the solenoid valve (See **Note**).
4. To store the support device, raise it up until it contacts the lift arm. Slide the lock pin through the support device and catch under the lift arm. Once the pin is secure, flip the lock pin loop so that it locks the pin in.



**Fig. 5: Lock Pin in "Locked" Position**

## Accessory Plug (Optional)

The optional accessory plug is located at the bottom of the left instrument panel.

## Engine Speed Control

A right-hand controlled throttle lever is provided on all models for adjusting the engine speed. Move the control forward to increase the engine speed and rearward to decrease the engine speed.

**T-Bar Controls Only:** A right-foot operated accelerator pedal is provided to control the engine RPM. The pedal linkage is spring-loaded to return to the adjusted hand-operated throttle setting.

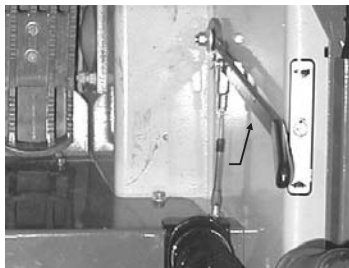

**Fig. 6: Throttle Lever**



**Fig. 7: Foot Pedal (T-Bar)**

## Instrument Panel

The instrument panel contains the following switches and indicators. Symbols on the panel represent various functions and conditions, and are visible only when indicator lamps are on.

1. **Hourmeter** - Indicates the total operating hours of the loader.
2. **Fuel Level Gauge** - Indicates the amount of fuel in the tank.
3. **Engine Coolant Temperature Gauge (optional)** - Indicates the engine coolant temperature.

**Note:** Items 4 through 9 are indicator lights which display the following:

4. **Fasten Seatbelt** - A momentary visual (and audible) indicator to remind the operator to fasten the seatbelt.
5. **Engine Oil Pressure** - Lights if the engine oil pressure drops too low, warning the operator to immediately stop the engine and determine the cause for the pressure drop. During normal operation, this indicator should be OFF.
6. **Battery** - Lights if the charging voltage is too high or too low. During normal operation, this indicator should be OFF.
7. **Preheat Indicator Lamp** - Lights when the preheat switch is pressed. During normal operation, this indicator should be OFF.
8. **Engine Coolant Temperature** - Lights if the engine coolant gets too hot, warning the operator to stop the engine. Allow the engine to cool, determine the cause for the high temperature and correct the problem before restarting the engine. During normal operation, this indicator should be OFF.

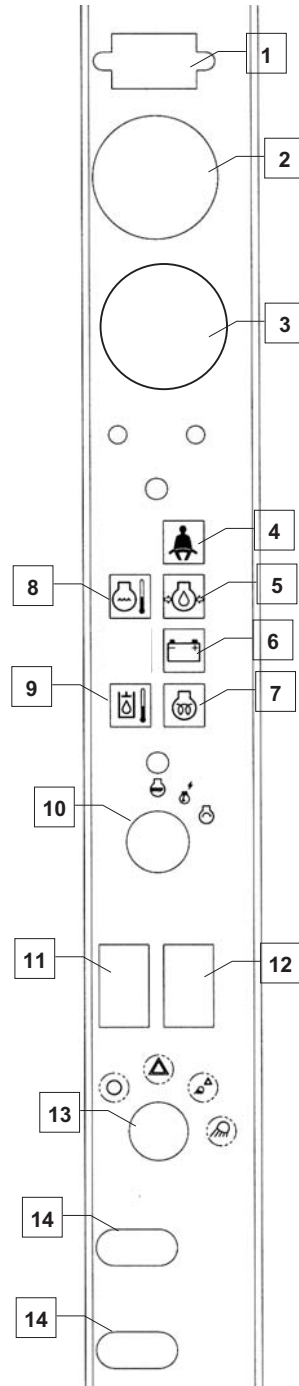

Fig. 8: Instrument Panel



**9. Hydraulic Oil Temperature** - Lights if the hydraulic oil becomes too hot, warning the operator to stop engine. Allow the hydraulic system to cool and determine the cause of the high temperature. During normal operation, this indicator should be OFF.

**10. Keyswitch** - In a clockwise rotation, these positions are:

**Off Position** - With the key vertical (OFF) in the keyswitch, power from the battery is disconnected to the controls and instrument panel electrical circuits. This is the only position the key can be inserted or removed from the keyswitch.

**On or Run Position** - With the key turned one position clockwise (RUN) from the vertical (OFF) position, power from the battery is supplied to all control and instrument panel electrical circuits.

**Start Position** - With the key turned fully clockwise (START) and held in position, the electric starter energizes, starting the engine. Release the key after the engine starts (it returns to the RUN position by itself).

**Note:** *The engine cannot be started unless the operator sits in the seat and the restraint bar is lowered.*

**11. Parking Brake Switch** - Used to manually apply the parking brake. The red indicator on the switch lights when the parking brake is applied.

**12. Preheat Switch** - Used to preheat the engine in cold conditions.

**13. Light Switch** - Controls all the lights (standard and optional) on the loader. Symbols denote the three positions of the light switch. In a clockwise direction these are: Off, Flashers (Hazards) and Worklights with Flashers. For the lights to function, the keyswitch must be in the RUN position.

**14. Circuit Breakers** - Four circuit breakers on the instrument panel protect the loader's electrical circuits.

**Important:** *Do not attempt to defeat the circuit protection by jumping across a circuit breaker or by using a higher amperage circuit breaker.*

## T-Bar Controls

---

Your Gehl loader may be equipped with the T-Bar control option. The left T-Bar controls the drive and the right T-Bar controls the lift/tilt.

### Drive Control

Forward, reverse, speed and turning maneuvers are accomplished by movement of the left T-Bar. To go **forward**, push the control forward; for **reverse**, pull the control rearward. To turn **right**, turn the control clockwise; to turn **left**, turn the control counterclockwise. For gradual turns, move the T-Bar slightly forward or rearward. For sharp turns, do not move the control forward or rearward.

Moving the T-Bar farther from neutral increases the speed steadily to the maximum travel speed. Tractive effort decreases as speed increases. To get maximum tractive effort, move the T-Bar only part way from the neutral position. The engine will stall if the controls are moved too far forward when loading the bucket.

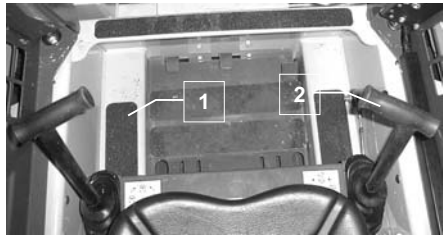

**Fig. 9: T-Bar Controls**

1. Drive Control
2. Lift/Tilt Control



**WARNING** Be sure the T-Bar controls are in neutral before starting the engine. Operate the T-Bars gradually and smoothly. Excessive speed and quick T-Bar movements without regard for conditions and circumstances are hazardous and could cause an accident.

---

## **Lift/Tilt Control**

Moving the lift arm and tilting the attachment are accomplished by movement of the right T-Bar. To **raise** the lift arm, pull the control straight rearward; to **lower** the lift arm, push the control straight forward. To **tilt the attachment downward**, twist the control clockwise; to **tilt the attachment up** or back, twist the control counterclockwise.

**Note:** *The speed of the lift/tilt motion is directly proportional to the amount of T-Bar movement and engine RPM.*

To place the lift arm in the detent (float) position, push the right T-Bar all the way forward, into the detent. This position allows the lowered lift arm to float while traveling over changing ground conditions.



**WARNING** Never push the lift/tilt T-Bar control into the float position with the attachment loaded or raised, because this will cause the lift arm to lower rapidly.

---

## Hand/Foot Controls

---

Your Gehl loader may be equipped with the hand/foot control option. The handles control the drive and the foot pedals control the lift/tilt.

### Drive Controls

Forward, reverse, speed and turning maneuvers are accomplished by movement of the control handles. To go **forward**, push both handles forward; for **reverse**, pull both handles rearward. For **turning**, move one handle farther forward or rearward than the other handle. Turn direction is determined by which handle is moved the farthest forward; to turn left, move the right handle farther forward than the left handle. For sharp turns, move the handles in opposite directions.

Moving the handles farther from neutral increases the speed steadily to the maximum travel speed. Tractive effort decreases as speed increases. To get maximum tractive effort, move the handles only part way from the neutral position. The engine will stall if the control is moved too far when loading the bucket.

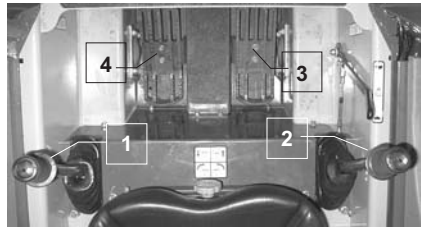

**Fig. 10: Hand/Foot Controls**

1. Left Drive Control Handle
2. Right Drive Control Handle
3. Tilt Control Foot Pedal
4. Lift Control Foot Pedal



### **WARNING**

Be sure the controls are in neutral before starting the engine. Operate the controls gradually and smoothly. Excessive speed and quick control movements without regard for conditions and circumstances are hazardous and could cause an accident.

---

## **Lift/Tilt Controls**

Moving the lift arm and tilting the attachment are accomplished by movement of the foot pedals. The left pedal raises and lowers the lift arm; the right pedal tilts the attachment. To **raise** the lift arm, use your heel to push down on the left pedal; to **lower** the lift arm, use your toes to push down on the left pedal. To **tilt the attachment downward**, use your toes to push down on the right pedal; to **tilt the attachment up** or back, use your heel to push down on the right pedal.

**Note:** *The speed of the lift/tilt motion is directly proportional to the amount of pedal movement and engine RPM.*

To place the lift arm in the detent (float) position, use your toes to push the left pedal all the way down, into the detent. This position allows the lowered lift arm to float while traveling over changing ground conditions.



### **WARNING**

**Never push the left pedal into the float position with the attachment loaded or raised, because this will cause the lift arm to lower rapidly.**

---

## Dual Hand Controls

---

Your Gehl loader may be equipped with the dual hand control option. The left handle controls the left side drive and the lift. The right handle controls the right side drive and the tilt.

## Drive Control

Forward, reverse, speed and turning maneuvers are accomplished by pushing and pulling the handles. To go **forward**, push both handles forward; for **reverse**, pull both handles rearward. For **turning**, move one handle farther forward or rearward than the other handle. Turn direction is determined by which handle is moved farther forward; to turn left, move the right handle farther forward than the left handle. For sharp turns, move the handles in opposite directions.

Moving the handles farther from neutral increases the speed steadily to the maximum travel speed. Tractive effort decreases as speed increases. To get maximum tractive effort, move the handles only slightly away from the neutral position. The engine will stall if the control is moved too far when loading the bucket.



### **WARNING**

**Be sure the controls are in neutral before starting the engine. Operate the controls gradually and smoothly. Excessive speed and quick control movements without regard for conditions and circumstances are hazardous and could cause an accident.**

---

## **Lift/Tilt Control**

Moving the lift arm and tilting the attachment are accomplished by rotating the control handles. To **raise** the lift arm, rotate the left control up; to **lower** the lift arm, rotate the left control down. To **tilt the attachment downward**, rotate the right control up; to **tilt the attachment up** or back, rotate the right control down..

**Note:** *The speed of the lift/tilt motion is directly proportional to the amount of control movement and engine RPM.*

To place the lift arm in the detent (float) position, push the left control all the way down, into the detent. This position allows the lowered lift arm to float while traveling over changing ground conditions.



**WARNING** Never push the lift/tilt control into the float position with the attachment loaded or raised, because this will cause the lift arm to lower rapidly.

---

## Auxiliary Hydraulic Controls

Auxiliary hydraulics are used with an attachment that has a mechanism requiring hydraulic power of its own.

**Important:** *Always be sure the auxiliary hydraulic control is in neutral before starting the loader or removing the auxiliary hydraulic couplers.*

Coupler hookup is located on the left lift arm. “A” port is pressure, “B” port is return when the auxiliary control is in the detent position (refer to page 35).

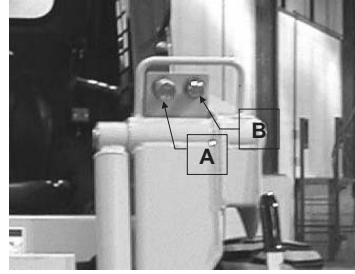

Fig. 11: Auxiliary Couplers

### T-Bar Controlled Loaders

A foot pedal is used to control the direction of oil flow. Pushing the right side of the foot pedal all the way to the right will put the control valve in the detent position for continuous operation.

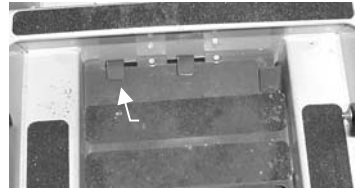

Fig. 12: T-Bar Auxiliary Control

### Hand/Foot Controlled Loaders

The right handle controls the direction of oil flow. Pushing the handle all the way to the right (Fig. 14, position “Ad”) will put the control valve in the detent position for continuous operation.



Fig. 13: Hand/ Foot Auxiliary Control

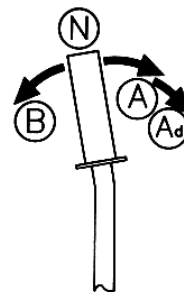

Fig. 14: Hand/ Foot Auxiliary Control Operation



## Attachment Mounting

---

The Gehl loader is equipped with a two-pin All-Tach™ attaching mechanism (hitch) for mounting a bucket or other attachment. Two latch levers secure the attachment. Rotate the levers until they are horizontal to engage the lock pins. Rotate the levers until they are vertical to disengage the lock pins.



**WARNING** To prevent unexpected attachment release from the hitch, be sure to secure the lock pins by rotating the levers downward into a horizontal position.

---



Fig. 15: All-Tach™ Attaching Mechanism (Hitch)

## Notes

# OPERATION



## **WARNING**

Before starting the engine and operating the loader, review and comply with all safety recommendations in the *Safety* chapter of this manual. Know how to stop the loader before starting it. Also, be sure to fasten and properly adjust the seatbelt and lower the operator restraint bar.

## **Before Starting the Engine**

Before starting the engine and running the loader, refer to the *Controls and Safety Equipment* chapter and familiarize yourself with the various operating controls, indicators and safety devices on the loader.

## **Starting the Engine**

The following procedure is recommended for starting the engine:

1. Carefully step up onto the back of the bucket or attachment and grasp the ROPS hand holds to get into the operator's compartment.
2. Fasten the seatbelt and lower the restraint bar.
3. Verify the following:
  - » the lift/tilt, drive and auxiliary controls are in their neutral positions
  - » the brake is on
4. Push the throttle lever forward to half speed.

**Note:** *When the key is turned to the RUN position, an indicator will light on the instrument panel and a buzzer will sound momentarily to remind you to check that your seatbelt is fastened.*

5. Turn the keyswitch to the START position.

**Important:** *Do not engage the starter for longer than 15 seconds at a time. Longer use can overheat and damage the starter. Allow the starter to cool for 20 seconds between uses.*

After the engine starts, allow a sufficient warm-up time before attempting to operate the controls.

**Important:** *If the warning lights do not go off, stop the engine and investigate the cause.*

## Cold Starting Procedure

---



**WARNING** Do not use starting fluid (ether) with preheat systems. An explosion can result which can cause engine damage, injury or death.

---

Push the PREHEAT button on the instrument panel for a maximum of 30 seconds to preheat the engine. If the temperature is below 32° F (0° C), try the following to make starting the engine easier:

- » Replace the engine oil with SAE 5W30.
- » Make sure the battery is fully charged.
- » Install a block heater on the engine.

Let the engine run for a minimum of five minutes to warm the engine and hydraulic fluid before operating the loader.

## Stopping the Loader

---

The following procedure is the recommended sequence for stopping the loader:

1. Check that the drive control handle(s) is(are) are in “neutral” position.
2. Lower the lift arm and rest the attachment on the ground.
3. Pull the throttle lever back to the idle position (and/or take your foot off the accelerator pedal for hands-only controlled machines).
4. Turn the keyswitch to the OFF position to shut off the engine.
5. Raise the restraint bar, unlatch the seatbelt and grasp the hand holds while climbing out of the operator’s compartment.

**Note:** *The skid loader is equipped with a spring-applied automatic parking brake. The parking brake is engaged when the operator lifts the restraint bar, leaves the operator’s seat, shuts off the engine or when the brake switch is applied (the bottom half of the switch is pushed in).*

## Parking the Loader

---

Park the loader on level ground away from traffic. If this is not possible, park the loader across the incline and block the tires to prevent movement.

## Jump Starting the Battery

---

If the battery becomes discharged or does not have enough power to start the engine, use jumper cables and the following procedure to jump start the engine.



The only safe method for jump starting a discharged battery is for two people to perform the following procedure. The second person removes the jumper cables so that the operator does not have to leave the operator's compartment with the engine running.

Never make jumper cable connections directly to the starter solenoid of either engine. Do not start the engine from any position other than the operator's seat and then only after being sure all controls are in "neutral."

Closely follow the procedure in order to avoid personal injury. In addition, wear safety glasses to protect your eyes. Avoid leaning over the batteries while jump starting.

**Do not jump start the battery if it is frozen, because it may rupture or explode. Warm the battery to 60 F (16 C) before connecting to a charger.**

---

**Note:** *Be sure the jumper battery is a 12 volt D.C. battery.*

1. Turn the keyswitches of both machines to OFF. Be sure the machines are in "neutral" and NOT touching each other.
2. Connect the positive (+) jumper cable to the positive (+) battery terminal on the disabled loader first. Do not allow the jumper's positive cable clamps to touch any metal other than the positive (+) battery terminals. Connect the other end of the positive jumper cable to the jumper machine's battery positive (+) terminal.
3. Connect the negative (-) jumper cable to the jumper machine's battery negative (-) terminal.

**Important:** *Do not use the loader frame as ground or damage will occur to the engine-to-frame groundwire.*

4. Make the final negative (-) jumper cable connection to the disabled loader's engine block (ground) — NOT to the disabled battery's negative (-) post. When connecting to the engine, keep the jumper clamp away from the battery, fuel lines and moving parts.
5. Be sure the brake switch is engaged and that the controls are in neutral. Start the engine. If it does not start at once, start the jumper machine's engine to avoid excessive drain on the booster battery.
6. After the disabled loader is started and running smoothly, have the second person remove the jumper cables (negative (-) jumper cable first) from the jumper machine's battery and then from the disabled loader while being sure NOT to short the two cables together.

Allow sufficient time for the skid loader alternator to build up a charge in the battery before attempting to operate the loader or shut off the engine.

## Changing Attachments

**WARNING** To prevent unexpected attachment release from the hitch, be sure to properly secure the hitch lock pins by rotating the latch levers to a horizontal position.

The skid loader features a All-Tach™ attaching mechanism (hitch) for mounting a bucket or other attachment. Two latch levers secure the attachment.

### Connect Attachment

1. Rotate the latch levers to a vertical position to fully retract the latch pins.
2. Start the loader engine and make sure the lift arm is lowered and in contact with the loader frame.
3. Align the loader squarely with the back of the attachment.
4. Tilt the hitch forward until the top edge of the hitch is below the flange on the back side of the attachment and centered between the vertical plates.
5. Slowly drive the loader forward and, at the same time, tilt the hitch back to engage the flange on the back side of the attachment.
6. Stop forward travel when the flange is engaged, but continue to tilt the hitch back to lift the attachment off the ground.
7. Exercise the MANDATORY SAFETY SHUTDOWN PROCEDURE (page 7).
8. With the loader engine OFF, leave the operator's compartment and rotate the latch levers to a horizontal position to fully engage the latch pins.



**Fig. 16: Hitch - disengaged**

1. Latch Levers
2. Latch Pins

**Important:** To check that the attachment is properly installed, apply down pressure to the attachment prior to operating.

## **Connect Auxiliary Hydraulic Couplings**

**Note:** *With the engine OFF, key in the ON position and the restraint bar down, the auxiliary hydraulic control can be moved to relieve any pressure in the hydraulic system.*

Coupler hookup is located on the left lift arm. “A” port is pressure, “B” port is return when the auxiliary control is in the detent position.

## **Remove Attachment**

1. Tilt the hitch back until the attachment is off the ground.
2. Exercise the MANDATORY SAFETY SHUTDOWN PROCEDURE (page 7).
3. Relieve any hydraulic pressure in the auxiliary and attachment lines.
  - a. Turn the key ON (do not start the engine).
  - b. With the restraint bar down, move the auxiliary hydraulic control back and forth. This will relieve the pressure in the hydraulic system.
4. With the engine OFF, leave the operator’s compartment, disconnect the auxiliary hydraulic hoses and rotate the hitch’s latch levers completely vertical to fully retract the latch pins.
5. Start the engine and be sure that the lift arm is fully lowered and in contact with the loader frame.
6. Tilt the hitch forward and slowly back the loader until the attachment is free from the loader.

## **Self-Leveling (optional)**

---

The feature is designed to keep the attachment level while the lift arm is being raised.

## Using a Bucket

---

**WARNING** Always maintain a safe distance from electric power lines and avoid contact with any electrically charged conductor or gas line. Accidental contact or rupture can result in electrocution or an explosion. Contact the “Digger’s Hotline” or proper local authorities for utility line locations before starting to dig.

---

### Driving over Rough Terrain

When traveling over rough terrain, drive slowly with the bucket lowered.

### Driving on an Incline

When traveling on an incline, the loader must travel with the heavy end pointing uphill.

### Digging with a Bucket

Approach the digging site with the lift arm slightly raised and the bucket tilted forward until the edge contacts the ground. Break the ground by driving forward and gradually lowering the lift arm.

With the bucket filled, tilt the bucket back, back the loader away from the material and rest the lift arm against the loader frame before proceeding to the dumping area.

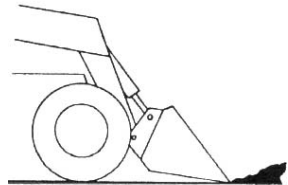

Fig. 17: Digging

**WARNING** Always carry the loaded bucket with the lift arm resting on the loader frame. For additional stability when operating on inclines, always travel with the heavier end of the loader toward the top of the incline.

---

### Loading a Bucket

Approach the pile with the lift arm fully lowered and the bucket tilted slightly forward until the edge contacts the ground. Drive forward, lifting the lift arm and tilting back the bucket to fill it. Back away from the pile.

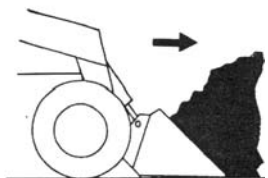

Fig. 18: Loading



## Dumping the Load Onto a Pile

Carry a loaded bucket as low as possible until reaching the pile. Gradually stop forward motion and raise the lift arm high enough so that the bucket clears the top of the pile. Then, slowly move the loader ahead to position the bucket to dump the material on top of the pile. Empty the bucket and back the loader away tilting the bucket back while lowering the lift arm.



**WARNING** Never push the controls into the float position with the bucket or attachment loaded or raised, because this will cause the lift arm to lower rapidly.

## Dumping the Load Into a Box

Carry the loaded bucket low and approach the vehicle or bin. Stop your approach as close to the side of the box as possible while allowing for clearance to raise the lift arm and loaded bucket. Next, raise the lift arm until the bucket clears the top of the box and move the loader ahead to position the bucket over the inside of the box. After the material is dumped, back away from the box tilting the bucket back while lowering the lift arm.



Fig. 19: Dumping Into a Box

## Dumping the Load Over an Embankment



**WARNING** Do not drive too close to an excavation or ditch. Be sure the surrounding ground has adequate strength to support the weight of the loader and the load.

Carry the loaded bucket as low as possible while traveling to the dumping area. Stop the loader where the bucket extends half-way over the edge of the embankment. Tilt the bucket forward and raise the lift arm to dump the material. After the material is dumped, back away from the embankment tilting the bucket back while lowering the lift arm.

## Scraping with a Bucket

For scraping, the loader should be operated in the forward direction. Position the lift arm down against the loader frame. Tilt the bucket cutting edge forward at a slight angle to the surface being scraped. While traveling slowly forward with the bucket in this position, material can flow over the cutting edge and collect inside the bucket.

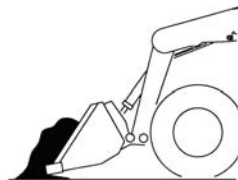
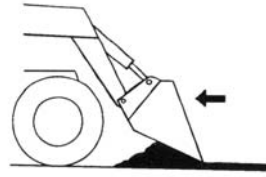

Fig. 20: Scraping

## **Leveling the Ground**

Drive the loader to the far edge of the area to be leveled. Tilt the bucket forward to place the bucket cutting edge at a 30 to 45 degree angle to the surface being leveled. Then place the lift arm into the “float” position and drive the loader rearward dragging the dirt and, at the same time, leveling it.



**Fig. 21: Leveling the Ground**

**Note:** *The float (detent) position for T-Bar controlled loaders is reached by pushing the right handle all the way forward. For hand/foot controlled loaders, use your toes to push the front of the left pedal all the way down.*



**WARNING** Check that the work area is clear of people and obstacles. Always look in the direction of travel.

## **Highway Travel**

If it becomes necessary to move the loader a long distance, obtain and use a properly rated trailer. For short distance highway travel, attach an SMV (Slow Moving Vehicle) emblem (purchased locally) to the back of the loader. For highway operation, obtain and install dual amber flashers or a strobe light. Check state and local laws and regulations.

## **Lifting the Loader**

The loader can be lifted using a four-point lift kit, which is available from your authorized Gehl dealer.

## **Storing the Loader**

If your skid loader is to be stored for a long period of time, the following procedure is suggested:

1. Fully inflate the tires.
2. Lubricate all grease zerks.
3. Check all fluid levels and replenish as necessary.
4. Add stabilizer to the fuel per the fuel supplier’s recommendations.
5. Remove the battery, charge fully and store in a cool, dry location.
6. Protect against extreme weather conditions such as moisture, sunlight and temperature.

## Transporting the Loader

---



**WARNING** Park the truck or trailer on a level surface. Be sure the vehicle and its ramps have the weight capacity to support the loader. Make sure the vehicle surface and its ramps are clear of debris and slippery material that may reduce traction. Move the loader on and off the vehicle ramp slowly and carefully. Failure to follow these instructions could result in an overturn accident.

---

Observe all local regulations governing the loading and transporting of equipment. Ensure that the hauling vehicle meets all safety requirements before loading the skid loader.

1. Place blocks at the front and rear of the hauling vehicle's tires.
2. If the loader has an attachment, lift it slightly off the ground.
3. Back the loader slowly and carefully up the ramp onto the vehicle.
4. Lower the loader attachment to the vehicle deck, turn off the engine and remove the key.
5. Fasten the loader to the hauling vehicle at the points indicated by the tie-down decals.
6. Measure the clearance height of the loader and hauling vehicle. Post the clearance height in the cab of the vehicle.

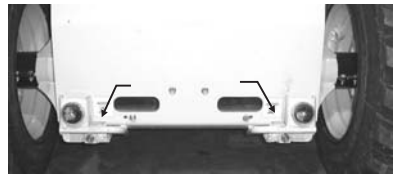

Fig. 22: Front Tie Downs

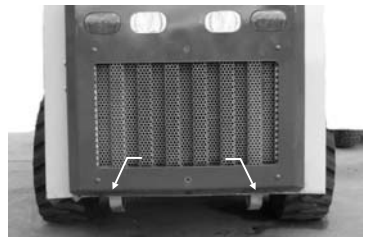

Fig. 23: Rear Tie Downs

# SERVICE



## **WARNING**

Before servicing the machine, unless expressly instructed to the contrary, exercise the **MANDATORY SAFETY SHUTDOWN PROCEDURE** (page 7).

**After service has been performed, be sure to restore all guards, shields and covers to their original positions before resuming loader operation.**

This *Service* chapter details procedures for performing routine maintenance checks, adjustments and replacements. Most procedures are referred to in the *Troubleshooting* and *Maintenance Schedule* chapters of this manual. Refer to the separate engine manual provided for engine-related adjustments, lubrication and servicing procedures.

**Note:** *All service procedures, except those described under the “Dealer Services” topic are owner-operator responsibilities.*

**Important:** *More frequent service than the recommended intervals may be required under severe operating conditions. You must decide if your operation requires more service.*

**Important:** *Always dispose of waste lubricating oils and hydraulic fluids according to local regulations or take to a recycling center for disposal. Do not pour onto the ground or down the drain.*

## **Dealer Services**

The following areas of component service, replacement and adjustments require special tools and knowledge for proper servicing and should be performed only by your authorized Gehl skid steer loader dealer: Hydrostatic Components, Hydraulic System Gear Pump, Valves, Cylinders, Electrical Components (other than the battery, circuit breakers) .

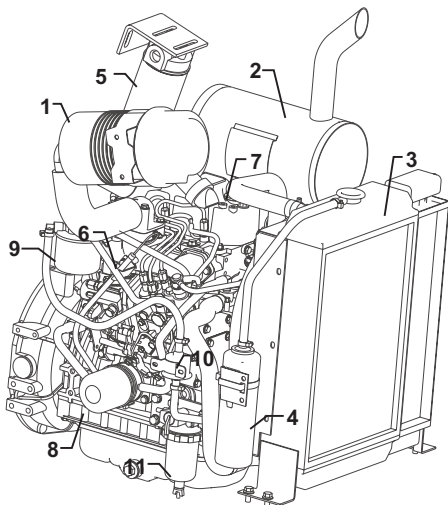

**Fig. 24: Engine Compartment**

1. Air Cleaner
2. Muffler
3. Radiator/Cooler
4. Coolant Recovery Tank
5. Hydraulic Oil Filter
6. Engine Oil Dipstick
7. Engine Oil Fill Cap
8. Engine Oil Filter
9. Fuel Filter
10. Fuel Pump
11. Water Trap

## Tilting the ROPS Back

---

For service, unbolt the two anchor bolts at the front of the ROPS and tilt it back slowly, moving the control handles out of the way. A gas-charged spring helps tilt it back. A self-actuating lock mechanism engages to lock the ROPS in a rolled-back position. To lower the ROPS, apply upward force on it while pulling the lock mechanism handle toward the front of the loader. Lower the ROPS slowly onto the chassis, moving the control handles out of the way. Reinstall the anchor bolts, washers and locknuts.



**Fig. 25: ROPS Lock Mechanism**



**WARNING** Never operate the loader with the ROPS removed or locked back. Be sure the lock pin is securely engaged when the ROPS is tilted back. Properly support the ROPS when unlatching the lock mechanism and lowering the ROPS. Be sure to reinstall the anchor bolts, washers and locknuts before resuming loader operation.

---

## Loader Raising Procedure

---

To raise the skid loader so all four tires are not contacting the ground, use the procedure below:

**⚠️ WARNING** Do not rely on a jack or hoist to maintain the “raised” position without additional blocking and supports. Serious personal injury could result from improperly raising or blocking the skid loader.

---

1. Using a jack or hoist capable of lifting the fully-equipped weight of the loader (with all attached options), lift the rear of the loader until the rear tires are off the ground.
2. Stack wooden blocks under the flat part of the loader chassis. They should run parallel with, but not touch, the rear tires (see Fig. 26).
3. Slowly lower the loader until its weight rests on the blocks. If the tires still touch the ground, raise the loader again, add more blocks and lower again.
4. Repeat Steps 1 through 3 for the front end. When the procedure is finished, all four tires will be off the ground so they can be removed.

## Loader Lowering Procedure

---

When service or adjustment procedures are complete, the skid loader can be taken down from the “raised” position. To lower the loader onto its tires:

1. Using a jack or hoist, raise the front of the loader until its weight no longer rests on the front blocks.
2. Carefully remove the blocking under the front of the loader.
3. Slowly lower the loader until the front tires are resting on the ground.
4. Repeat Steps 1 through 3 for the rear of the loader. When the procedure is finished, all four tires will be on the ground and the blocks removed from under the loader.

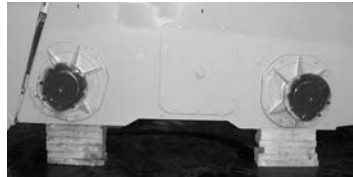

Fig. 26: Blocked Loader

## Replacement Parts

Part Description	Gehl Part No.
Air Cleaner Element, Primary	420-36075
Air Cleaner Element, Secondary	420-36076
Hydraulic Oil Filter Element	170-35067
Engine Oil Filter Element	162558
Fuel Filter Cartridge	425-34636

**Note:** *Part numbers may change. Your Gehl dealer will always have the latest part numbers.*

## Adjustments

### Control Handles

The control handles do not require routine adjustment. Refer to the *Service Manual* for the initial setup procedure.

### Fuel Sender

The fuel sender, located in the engine compartment, sends a signal to the fuel gauge indicating the amount of fuel in the fuel tank.

Check the fuel sender periodically to ensure that the mounting screws are tight and that there is no fuel seepage around the gasket. If adjustment is required, apply an RTV or gasket sealant around the gasket when restoring the fuel sender.

### Engine Speed Control

The throttle cable does not require routine adjustment. Refer to the *Service Manual* for the initial setup procedure.

Besides throttle cable adjustment, the throttle lever friction pad pressure can be readjusted if the throttle lever does not hold its position. Belleville washers and a lock nut on the throttle lever are used for making this adjustment.

### Drive Chains

The drive chains do not require routine adjustment. Refer to the *Service Manual* for the initial setup procedure.

## Lubrication

Listed below are the locations, temperature ranges and types of recommended lubricants to be used when servicing this machine. Refer to the separate engine manual for more information regarding recommended engine lubricants, quantities required and grades.

<b>Hydraulic System Oil</b>	Use Mobil DTE 15M or equivalent which contains anti-rust, anti-foam and anti-oxidation additives, and conforms to ISO VG46. <b>Capacity:</b> 8 U.S. gallons (30 liters)
<b>Chaincase Oil</b>	Use hydraulic system oil or SAE grade motor oil. <b>Capacity</b> (each side): 3635 - 4.5 U.S. gallons (17 liters) 3935 - 5.0 U.S. gallons (19 liters)
<b>Grease Fittings</b>	Use lithium based grease
<b>Engine Oil</b>	Below 32°F (0°C) - Use SAE Grade* 10 or 10W-30 Above 32°F (0°C) - Use SAE Grade* 15W-40 *Service Classification: API - CF-4/CG-4 <b>Capacity:</b> 5 U.S. quarts (4,8 liters)

Refer to the following figure for grease fitting locations. Wipe dirt from the fittings before greasing them to prevent contamination. Replace any missing or damaged fittings. To minimize dirt build-up, avoid excessive greasing.



**Fig. 27: Grease Every 10 Hours (or daily)**

1. Lift arm pivots (2)
2. Lift cylinder pivots (4)
3. Tilt cylinder pivots (2)
4. Hitch pivots (2)



## Engine Air Cleaner

**Important:** Failure to follow proper filter servicing instructions could result in catastrophic engine damage.

The air cleaner consists of an outer (primary) filter element and an inner (secondary) filter element. An air filter restriction indicator for monitoring the condition of the elements is located on the right side of the front of the air cleaner. If the air filter becomes restricted, this indicator will turn red to warn the operator that the element(s) require service. Push the reset button located at the end of the indicator after fitting a clean element. For replacement elements, refer to the “Replacement Parts” topic (page 44).

**Note:** Before replacing the filter element(s), push the reset button on the indicator. Start the engine and adjust the throttle to full speed. If the indicator does not turn red, do **not** replace the element(s).

The outer element should be replaced only when the restriction indicator turns red. The inner element should be replaced every third time the outer element is replaced, unless the outer element is damaged or the inner element is dirty.

Along with a daily check of the restriction indicator, check the air cleaner intake hose and clamps, and the mounting bracket hardware for secureness.

### Access

1. Open the rear door and engine access cover.
2. Unlatch the two latches on the air cleaner and remove the cover. Clean out any dirt built up in the cover assembly.

### Outer Element

1. Carefully pull the outer element out of the housing. Never remove the inner element unless it is to be replaced.
2. Clean out any dirt built up in the housing. Leave the inner element installed during this step to prevent debris from entering the engine intake manifold.
3. Replace the outer element.

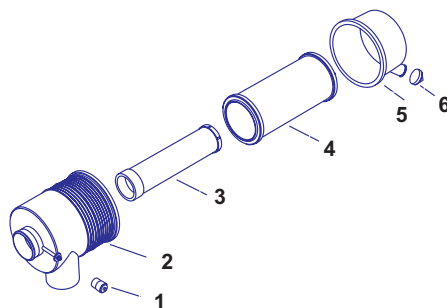

**Fig. 28: Dual Element Air Cleaner**

1. Restriction Indicator
2. Element Housing
3. Inner Filter Element
4. Outer Filter Element
5. Element Cover
6. Dust Ejector

**Note:** Gehl does not recommend cleaning the outer element.

4. Use a trouble light inside the outer element to inspect for spots, pinholes or ruptures. Replace the outer element if any damage is noted. The outer element must be replaced if it is oil- or soot-laden.

## **Inner Element**

**Note:** Replace the inner element only if it is dirty or if the outer element has been replaced three times.

1. Before removing the inner element from the housing, clean out any dirt built up in the housing. Leave the inner element installed during this step to prevent debris from entering the engine intake manifold. Remove the inner element.

## **Reinstallation**

1. Check the inside of the housing for any damage that may interfere with the elements.
2. Be sure that the element sealing surfaces are clean.
3. Insert the element(s), making sure that they are seated properly.
4. Secure the cover to the housing with the two clamps.
5. Check the hose connections and make sure they are all clamped and tightened properly.
6. Reset the indicator by pressing the reset button.

## **Engine Service**

---

### **Check Engine Mounting Hardware**

All bolts that secure the engine mounting brackets to the engine and the loader frame should be checked and re-tightened as necessary.

---

** **WARNING** Allow hot engine and hydraulic system components to cool before servicing.**

---

### **Check Engine Oil Level**

**Important:** For new units, the initial oil change should be after the first 50 hours.

Open the rear door and engine access cover. Pull out the dipstick and check the oil level. Markings on the dipstick represent FULL and LOW (add oil) levels.

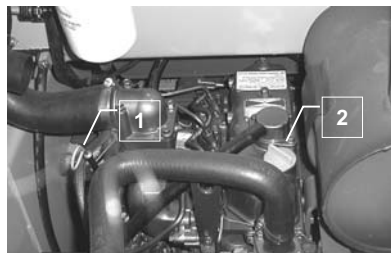

**Fig. 29: Oil Dipstick and Fill Cap**

1. Oil Dipstick
2. Oil Fill Cap

Refer to the *Maintenance Interval Chart* (page 65) for the service interval for replacing the engine oil and filter.

### **Change Engine Oil and Filter**

1. Run the engine until it is at operating temperature. Stop the engine. Remove the rear belly pan.
2. Remove the drain plug.
3. From the engine compartment, remove the oil filter. Clean the filter sealing surface.
4. Put clean oil on the new oil filter gasket. Install the filter and tighten  $3/4$  of a turn past the point where the gasket contacts the filter head.
5. Reinstall and tighten the drain plug.
6. Remove the oil cap and add the recommended oil. Refer to the “Lubrication” topic in this chapter for oil recommendations and capacities.
7. Start the engine and let it run for several minutes at low idle. Stop the engine. Check for leaks at the oil filter, drain plug and remote oil drain hose. Check the oil level. Add oil if it is not at the top mark on the dipstick.



**Fig. 30: Rear Belly Pan**

For a replacement element, refer to the “Replacement Parts” topic (page 44).

### **Change Fuel Filter**

The loader has a fuel filter located on the left side of the engine.

1. Shut off the fuel supply by turning the fuel shutoff valves on top of the fuel filter and by the air cleaner restriction indicator
2. Remove the filter element and bowl.
3. Clean the bowl, o-ring and o-ring groove. Lubricate the o-ring with diesel fuel and replace in the groove.
4. Place a new element in the bowl.
5. Lubricate the element gasket with diesel fuel.
6. Reinstall the filter assembly. Turn on the fuel supply.

The engine is self-priming, but if priming is needed, prime the filter assembly by stroking the pump lever until light resistance is felt.

For a replacement element, refer to the “Replacement Parts” topic (page 44).

## Hydraulic System

---

### Check Hydraulic Oil Level

The loader has a hydraulic oil level sight gauge located on the left side of the engine compartment. Check the fluid level with the lift arm lowered and the attachment on the ground.

When hydraulic fluid is required, allow the system to cool. Slowly remove the oil fill cap, allowing the pressure to dispel before removing the cap completely.

Add hydraulic fluid as required. Refer to the “Lubrication” topic (page 44) for oil recommendations. Replace the cap.



**Fig. 31: Hydraulic Oil Service**

1. Oil Level Sight Gauge
2. Oil Filter

### Change Hydraulic Oil Filter

---



#### **WARNING**

**Before servicing the hydraulic filter, be sure the lift arm is lowered.**

---

1. Open the rear door and engine cover to access the filter. Unscrew the filter.
2. Clean the surface of the filter housing where the element seal contacts the housing. Put clean oil on the rubber gasket of the new filter element.
3. Install and tighten the filter element 3/4 of a turn past the point where the gasket contacts the filter head.
4. For a replacement element, refer to the “Replacement Parts” topic (page 44).

### Change Hydraulic Oil

The hydraulic oil must be replaced if it becomes contaminated, after major repairs, and after 1000 hours or one year of use.

1. Remove the oil filler cap.
2. Install a catch pan of sufficient capacity under the oil reservoir (8 gallons, 30 liters)
3. Remove the drain plug located on the bottom left of the oil reservoir.
4. Remove and replace the hydraulic oil filter.
5. Reinstall the drain plug.
6. Refill the reservoir until the oil is between the two lines on the sight gauge.



**Fig. 32: Drain Plug**

7. Start the engine and operate the hydraulic controls.
8. Stop the engine and check for leaks at the filter and reservoir drain plug.
9. Check the fluid level and add fluid if needed.

## **Cooling System**

**Important:** *Check the cooling system every day to prevent overheating, loss of performance or engine damage.*

### **Check Coolant Level**

1. Open the rear door. Check the coolant level in the coolant recovery tank on the inside of the rear door. The coolant recovery tank must be 1/3 to 1/2 full with a cold engine and 2/3 to 3/4 full with a hot engine.
2. Allow the coolant to cool. Do not remove the cap when the coolant is hot. Serious burns may occur.
3. Add premixed coolant, 50% water and 50% ethylene glycol, to the recovery tank if the coolant level is low.

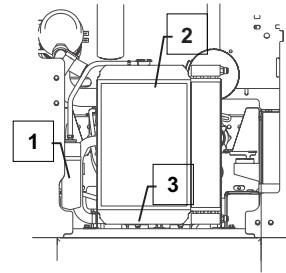

**Fig. 33: Cooling System**

1. Recovery Tank
2. Radiator/Cooler
3. Drain Plug

### **Clean Cooling System**

1. Park the loader on a level surface, lower the lift arm and stop the engine. Allow the machine to cool.
2. Open the rear door. Lift the engine cover.
3. Clean the radiator and oil cooler by blowing through the fins with high pressure water or air.

**Note:** *The radiator can be tipped out for cleaning by loosening and rotating the over-center links on each side. This will also help in cleaning the oil cooler.*

### **Drain/Flush Cooling System**

1. Open the rear door. Lift the engine cover.
2. Slowly remove the radiator cap, allowing pressure to dispel before removing completely.



**WARNING** Liquid cooling systems build up pressure as the engine gets hot. Before removing the radiator cap, stop the engine and let the system cool. Remove the radiator cap only after the coolant is cold. Remove the cap slowly or severe burns may result.

3. Remove the drain plug and drain the coolant into a suitable container.
4. Replace the drain plug.

**Note:** Protect the cooling system by adding premixed 50% water and 50% ethylene glycol to the system. This mixture will protect the cooling system to  $-34^{\circ}\text{F}$  ( $-36^{\circ}\text{C}$ ).

5. Fill the radiator fully and the recovery tank half full with the premixed coolant.
6. Reinstall the radiator cap.
7. Run the engine until it is at operating temperature. Stop the engine and let it cool. Check the coolant level. Add more fluid if required.

## **Chaincases**

---

The chaincase contains the drive sprockets and drive chains. There are two plugs in each chaincase. One is to drain the fluid and the other is to check the fluid level. Refer to the *Maintenance Schedule* chapter (page 65) for change intervals. Refer to the “Lubrication” topic (page 44) for information on oil type and quantity.

### **Checking and Adding Oil**

1. Park the loader on a level surface. Stop the engine.
2. Remove the check plug from each chaincase housing. If the oil can be reached with the tip of your finger, the oil level is adequate.
3. If the level is low, add fluid through the check plug until the oil level reaches the edge of the hole. Reinstall the check plug.

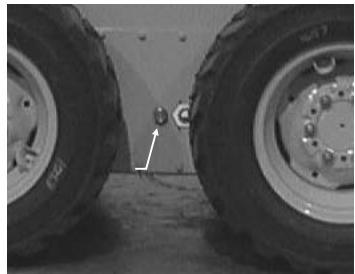

**Fig. 34: Check Plug**

### **Draining Oil**

1. Raise the rear of the machine to aid in draining the chaincases.
2. Remove the drain plug on each chaincase and drain the oil into a suitable container.
3. Reinstall and tighten the drain plugs.
4. Refill the chaincases at the check plugs.



**Fig. 35: Drain Plugs**

## **Spark Arrestor Muffler**

---

**Important:** *The loader is factory-equipped with a spark arrestor style muffler. Muffler maintenance is required to keep it in working condition. Refer to local laws and regulations for spark arrestor requirements.*

1. Stop the engine, open the rear door and engine cover.
2. Remove the plug from the bottom of the muffler.
3. Block the outlet of the muffler with a non-combustible material.
4. Start the engine and run it for 10-15 seconds.
5. Stop the engine and remove the blockage.
6. Put anti-seize coating on the plug.
7. Reinstall and tighten the plug.

## **Alternator/Fan Belt**

---

Refer to the separate engine manual for setting proper belt tension. If the belt is worn, cracked or otherwise deteriorated, replace the belt following the procedure in the separate engine manual.

## **Seat and Restraint Bar Switches**

---

Electrical switches in the seat and restraint bar must be closed (operator sitting in the seat and restraint bar lowered) to complete the circuit and start the engine.

## **Bucket Cutting Edge**

---

The bucket cutting edge should be replaced when it is worn to within 1" (25 mm) of the bucket body.

## **Wheel Nuts**

---

Wheel nut torque must be checked before initial operation and every two hours thereafter until the wheel mounting hardware torque setting stabilizes at the recommended setting 120-130 ft-lbs (161-175 N·m). When tires are removed and replaced, this procedure must be repeated.

## **Tires**

---

Rear tires usually wear faster than the front ones. To keep tire wear even, rotate the tires from front to rear and rear to front.

It is important to keep the same size tire on each side of the loader to prevent excessive wear on tires, chain and chaincase, or other damage. If different sizes are used, each tire will be turning at different speeds, causing excessive wear.

The tread bar of all tires must face the same direction.

## **Mounting Tires**

 **WARNING** Inflating or servicing tires can be dangerous. When possible, trained personnel should service and mount tires. To avoid possible death or serious injury, follow the safety precautions below:

1. Be sure the rim is clean and free of rust.
2. Lubricate the tire beads and rim flanges with a soap solution. Do not use oil or grease.
3. Use a clip-on tire chuck with remote hose and gauge, allowing you to stand clear while inflating the tire. Do not place your fingers on the tire bead or rim during inflation.
4. Never inflate beyond 35 PSI (240 kPa) to seat the beads. If the beads have not seated by the time the pressure reaches 35 PSI, deflate the assembly, reposition the tire on the rim, lubricate both parts and re-inflate. Inflation pressure beyond 35 PSI with unseated beads may break the bead or rim with explosive force sufficient to cause death or serious injury.
5. After seating the beads, adjust the inflation pressure to the recommended operating pressure.
6. Do not weld, braze or otherwise attempt to repair and use a damaged rim.

## **Check Tire Pressure**

Tire Size	Inflation Pressure	
	PSI	kPa
10 x 16.5 8-ply Heavy Duty Flotation	60	414
27 x 8.5 -15 8-ply Heavy Duty	60	414
27 x 10.5 - 15 8-ply Heavy Duty	60	414
6.5 x 16 - 5.50 Solid Rubber	-	-

Correct tire pressure should be maintained for all tires to enhance operating stability and extend tire life. Refer to the above chart for the proper inflation pressure.

When installing tires, be sure they are the same size and style on each side of the loader. Always replace tires with the same size as the original equipment.



## Electrical System

---

### Circuit Breakers

The circuit breakers for the loader are located on the right instrument panel. There is also a 35 amp main circuit breaker located on the right side of the engine compartment, directly behind the ROPS.

### Battery

---



**WARNING** Before servicing the battery or electrical system, be sure the battery disconnect switch (if equipped) is in the “OFF” position. If not equipped with a disconnect switch, disconnect the ground (-) terminal from battery.

---

The battery on the loader is a 12 volt, wet-cell battery. To access the battery, open the rear door and lift the engine cover.

The battery top must be kept clean. Clean it with an alkaline solution (ammonia or baking soda and water). After foaming has stopped, flush the battery top with clean water. If the terminals and cable connection clamps are corroded or have a build-up, disconnect the cables and clean the terminals and clamps with the same alkaline solution.

---



**WARNING** Explosive gas is produced while a battery is in use or being charged. Keep flames or sparks away from the battery area. ALWAYS charge the battery in a well-ventilated area.

Never lay a metal object on top of a battery, because a short circuit can result.

Battery acid is harmful on contact with skin or fabrics. If acid spills, follow these first-aid tips:

1. Immediately remove any clothing on which acid spills.
2. If acid contacts the skin, rinse the affected area with running water for 10 to 15 minutes.
3. If acid contacts the eyes, flood the eyes with running water for 10 to 15 minutes. See a doctor at once. Never use any medication or eye drops unless prescribed by the doctor.
4. To neutralize acid spilled on the floor, use one of the following mixtures:
  - a. 1 pound (0,5 kilogram) of baking soda in 1 gallon (4 liters) of water
  - b. 1 pint (0,5 liters) of household ammonia in 1 gallon (4 liters) of water

Whenever the battery is removed, be sure to disconnect the negative (-) battery terminal connection first.

---

## Notes

# TROUBLESHOOTING

## Electrical System

Problem	Possible Cause	Remedy
<b>Entire electrical system does not function.</b>	Battery disconnect switch is OFF.	Turn battery disconnect switch to ON.
	15 ampere breakers are tripped.	Check circuit and locate trouble before resetting breaker.
	Main wiring harness connectors at rear of ROPS not properly plugged in.	Check main harness connectors.
	Battery terminals or cables are loose or corroded.	Clean battery terminals and cables and retighten them.
<b>No instrument panel lamps with keyswitch turned to "ON."</b>	Battery is faulty.	Test battery and replace as needed.
	15 ampere breaker tripped.	Check circuit and locate trouble before resetting breaker.
<b>Seatbelt buzzer not sounding when key turned to "ON," indicator lamps work properly.</b>	Battery terminals or cables are loose or corroded.	Clean battery terminals and cables and retighten them.
	Buzzer is disconnected.	Reconnect wires to buzzer.
<b>Fuel gauge does not work.</b>	Faulty buzzer.	Replace buzzer.
	Faulty fuel gauge sender.	Replace fuel gauge sender.
	Faulty fuel gauge.	Replace fuel gauge.
<b>Engine temperature gauge does not work.</b>	Loose wiring/terminal connections.	Verify wiring connections.
	Faulty temperature sender.	Replace temperature sender.
	Faulty temperature gauge.	Replace temperature gauge.
	Loose wiring/terminal connections.	Verify wiring connections.
<b>Hourmeter does not work.</b>	Loose wiring/terminal connections.	Verify wiring connections.
	Faulty alternator.	Repair the alternator.
	Faulty hour meter.	Replace hour meter.

## Electrical System

Problem	Possible Cause	Remedy
<p><b>Starter will not engage when key is turned to START.</b></p>	<p>Seat or restraint bar switch malfunctioning or not activated.</p> <p>Poor connections to starter relay in instrument panel.</p> <p>Battery terminals or cables loose or corroded.</p> <p>Faulty starter relay in instrument panel.</p> <p>Battery discharged or defective.</p> <p>Starter solenoid not functioning.</p> <p>Ignition wiring, seat switch, restraint bar switch, etc. loose or disconnected.</p> <p>Starter or pinion faulty.</p>	<p>Replace switches as needed. If engine still doesn't start, contact your dealer.</p> <p>Verify relay connections.</p> <p>Clean terminals, cables and retighten.</p> <p>Contact your dealer.</p> <p>Recharge or replace battery.</p> <p>Troubleshoot circuit. Replace the starter solenoid.</p> <p>Check wiring for poor connections, broken leads; repair wiring or connection.</p> <p>Remove starter; repair/replace as needed.</p>
<p><b>Work lights not functioning properly.</b></p>	<p>Single light doesn't work: Light bulb burned out, faulty wiring.</p> <p>No lights at all; 15 ampere breaker tripped.</p> <p>Faulty light switch or poor ground.</p>	<p>Check and replace light bulb as needed. Check wiring connection to light.</p> <p>Check circuit and locate trouble before replacing fuse.</p> <p>Replace light switch. Check ground wire connections.</p>
<p><b>Lift/Tilt and/or drive lock solenoids do not work.</b></p>	<p>Wiring to solenoids disconnected or faulty.</p> <p>Faulty seat or restraint bar switch.</p> <p>Faulty solenoid valve coil.</p> <p>Faulty hydraulic solenoid relay in instrument panel.</p>	<p>Troubleshoot circuit, repair.</p> <p>Contact your dealer.</p> <p>Contact your dealer.</p> <p>Contact your dealer.</p>

## Engine

Problem	Possible Cause	Remedy
<b>Engine turns over but will not start.</b>	Engine cranking speed too slow.	Battery requires recharging or replacing, or, in cold temperatures, pre-warm the engine.
	Auxiliary valve engaged.	Return the control valves to neutral.
	Fuel tank empty or faulty fuel gauge sender.	Refill fuel tank. Replace fuel gauge sender.
	Glow plug module malfunctioning.	Check connection and voltage, replace as needed.
	Fuel shut-off solenoid not energizing.	Check electrical connections and voltage to shut-off solenoid.
	Engine oil not warm enough.	Install a pan heater.
	Ambient temperature is too low.	Install a pan heater.
<b>Engine overheats.</b>	Crankcase oil level too low or too high.	Add or remove oil as required.
	Fan air circulation blocked or restricted.	With engine OFF, remove blockage or restriction.
	Fan shroud improperly positioned.	Contact your dealer.
	Grade of oil improper or excessively dirty.	Drain and replace with proper grade new oil.
	Exhaust restricted.	Allow exhaust to cool, remove restriction.
	Air filter is restricted.	Replace the filter(s).

## Hydrostatic System

Problem	Possible Cause	Remedy
<b>No response from either the hydrostatic drive or the lift/tilt systems.</b>	Hydraulic oil viscosity is too heavy.	Allow longer warm-up or replace existing oil with the proper viscosity oil.
	Hydraulic oil supply is too low.	Check for low oil level in reservoir. Add oil.
	Drive coupling failure.	Replace the coupling.
<b>Traction drive will not operate in either direction.</b>	Parking brake is engaged.	Disengage parking brake.
	Hydraulic oil supply is low.	Check for low oil level in reservoir. Add oil.
	Control rod linkage disconnected.	Check linkage connection at control levers and neutral centering mechanisms. Reconnect linkage.
	Low or no charge pressure.	Contact your dealer.
<b>Sluggish response to acceleration.</b>	Hydrostatic pump(s) relief valves are malfunctioning.	Contact your dealer.
	Air in the hydraulic system.	Cycle lift and tilt cylinders to maximum stroke and maintain pressure for a short time to clear air from system. Also check for low oil level in reservoir, fill as needed.
	Automatic parking brake partially engaged.	Contact your dealer.
	Hydraulic oil supply is too low.	Check for low oil level in reservoir. Add oil.
	Low hydrostatic system charge pressure.	Contact your dealer.
Drive motor(s) or hydrostatic pump(s) have internal damage or leakage.	Contact your dealer.	

<p><b>Hydrostatic drive is overheating.</b></p>	<p>Drive system overloaded continuously.</p> <p>Lift/tilt or auxiliary system overloaded continuously.</p> <p>Drive motor(s) or hydrostatic pump(s) have internal damage or leakage.</p> <p>Oil cooler fins are plugged with debris.</p> <p>Loader being operated in a high temperature area with no air circulation.</p>	<p>Improve efficiency of operation.</p> <p>Improve efficiency of operation.</p> <p>Contact your dealer.</p> <p>Clean oil cooler fins.</p> <p>Reduce duty cycle; improve air circulation.</p>
---	---	--

## Hydrostatic System

Problem	Possible Cause	Remedy
<b>Hydrostatic (drive) system is noisy.</b>	<p>Hydraulic oil viscosity is too heavy.</p> <p>Air in hydraulic system.</p> <p>Drive motor(s) or hydrostatic pump(s) have internal damage or leakage.</p>	<p>Allow longer warm-up or replace existing oil with the proper viscosity oil.</p> <p>Cycle lift and tilt cylinders to maximum stroke and maintain pressure for a short time to clear air from system. Also check for low oil level in reservoir, fill as needed.</p> <p>Contact your dealer.</p>
<b>Right side doesn't drive in either direction. Left side operates normally.</b>	<p>Rear hydrostatic pump arm control shaft key missing.</p> <p>Relief valves on rear hydrostatic pump malfunctioning.</p> <p>Control rod linkage to rear hydrostatic pump disconnected.</p>	<p>Contact your dealer.</p> <p>Contact your dealer.</p> <p>Attach control rod linkage.</p>
<b>Right side doesn't drive in forward direction.</b>	<p>Relief valve on rear hydrostatic pump is malfunctioning.</p> <p>Rear hydrostatic pump malfunctioning.</p>	<p>Contact your dealer.</p> <p>Contact your dealer.</p>
<b>Left side doesn't drive in either direction. Right side operates normally.</b>	<p>Key missing on front hydrostatic pump arm control shaft.</p> <p>Relief valves on front hydrostatic pump malfunctioning.</p> <p>Control rod linkage to front hydrostatic pump disconnected.</p>	<p>Contact your dealer.</p> <p>Contact your dealer.</p> <p>Attach control rod linkage.</p>
<b>Left side doesn't drive in one direction.</b>	<p>Relief valve on front hydrostatic pump is malfunctioning.</p> <p>Front hydrostatic pump malfunctioning.</p>	<p>Contact your dealer.</p> <p>Contact your dealer.</p>



## Hydraulic System

Problem	Possible Cause	Remedy
<b>Lift/Tilt controls fail to respond.</b>	Hydraulic oil viscosity is too heavy.	Allow longer warm-up or replace with proper viscosity oil.
	Hydraulic oil level is low.	Check oil level in reservoir. If oil is low, check for an external leak. Repair and add oil.
	Solenoid valve(s) malfunctioning.	Check electrical connections to lift solenoid and repair.
	Restraint bar or seat switch malfunction.	Check switches.
<b>Auxiliary hydraulics do not function.</b>	Restraint bar is raised.	Lower the restraint bar.
	Lock solenoid malfunctioning	Check electrical connections to lock solenoid and repair connections as needed. If lock solenoid is still not functioning properly, contact your dealer.
	Restraint bar switch malfunctioning.	Check electrical connections to restraint bar switch and repair connections as needed. If switch is still not functioning properly, contact your dealer.
<b>Hydraulic cylinder action is slow for lift and/or tilt functions.</b>	Low engine speed.	Operate engine at higher speed.
	Hydraulic oil viscosity is too heavy.	Allow longer warm-up or replace existing oil with proper viscosity oil.
	Control linkage is restricted.	Check for control linkage restriction and adjust.
	Hydraulic oil leaking past cylinder piston seals.	Contact your dealer.
	Worn gear pump.	Contact your dealer.
	Solenoid valve(s) could be malfunctioning.	Check electrical connections to lift solenoid and repair connections as needed. If lift solenoid valve is still not functioning properly, contact your dealer.
	Relief valve in control valve not functioning correctly. (Squealing noise should be evident while operating.)	Contact your dealer.

<b>Bucket does not level on the lift cycle.</b>	Self-leveling valve misadjusted or malfunctioning.	Contact your dealer.
---	--	----------------------

## Hydraulic System

<b>Jerky lift arm and bucket action.</b>	Seat or restraint bar switch malfunction.	Check electrical connections to the switches. Replace as needed.
	Air in the hydraulic system.	Cycle lift/tilt cylinders to maximum stroke and maintain pressure for short time to clear air from system.
	Oil in hydraulic reservoir is low.	Check and add oil.
<b>Bucket drifts downward with tilt control in neutral.</b>	Oil leaking past tilt cylinder seals (internal or external).	Contact your dealer.
	Self-leveling valve is malfunctioning.	Contact your dealer.
	Leaking hydraulic hoses, tubes, or fittings between control valve and cylinders.	Inspect hoses and tubes, tighten fittings. Replace hoses or tubes as needed.
<b>No down pressure on the bucket.</b>	Control valve in float position.	Take control out of float position.
	Tilt cylinders are malfunctioning.	Contact your dealer.
	Relief valve in control valve not functioning properly. (Squealing noise should be evident while operating.)	Contact your dealer.
<b>Bucket will not tilt, lift arms work properly.</b>	Tilt solenoid valve malfunctioning.	Check electrical connections to tilt solenoid and repair connections as needed. If tilt solenoid valves are still not functioning properly, contact your dealer.
	Tilt spool in control valve not actuated or leaking.	Check valve control linkage and/or tube connections to valve.
<b>Slow or no response for bucket tilt, lift works properly (Hand/Foot units only).</b>	Pilot control lines have air in them.	Bleed the pilot control line from the main control valve.
	Low charge pressure.	Contact your dealer.
	Linkage misadjusted between right foot pedal and pilot valve.	Readjust for full travel without restriction.

## Hydraulic System

Problem	Possible Cause	Remedy
<b>Lift arm does not raise, bucket tilt works properly.</b>	Lift solenoid valve could be malfunctioning.	Check electrical connections to lift solenoid and repair connections as needed. If lift solenoid valve is still not functioning properly, contact your dealer.
	Lift spool in control valve not actuated or leaking.	Contact your dealer.
<b>Lift arm doesn't maintain raised position with lift control in NEUTRAL.</b>	Oil leaking past lift cylinder seals (internal or external).	Contact your dealer.
	Oil leaking past lift spool in control valve.	Contact your dealer.
	Self-leveling valve malfunctioning.	Contact your dealer.
	Leaking hydraulic hoses, tubes or fitting between control valve and cylinders.	Inspect hoses and tubes, tighten fittings as needed. Replace when needed.
<b>Lift arm will not lower or raise.</b>	Lift arm support device engaged.	Raise lift arm and disengage support device.
	Lift solenoid valve malfunctioning.	Check electrical connections to solenoid. Repair or replace as needed.
	Restraint bar not lowered.	Lower restraint bar.
	Seat or restraint bar switch malfunction.	Check electrical connections to the switch. Replace switch as needed.

# MAINTENANCE SCHEDULE

This Maintenance Interval Chart was developed to match the *Service* chapter of this manual. Detailed information on each service procedure may be found in the *Service* chapter. A Maintenance Log follows the chart for recording the maintenance performed. Recording the 10 hour (or daily) service intervals would be impractical and is therefore not recommended.

**Important:** *Under severe operating conditions more frequent service than the recommended intervals may be required. You must decide, based on your use, if your operation requires more frequent service.*

## Maintenance Interval Chart

Service Procedure	Maximum Interval		
	10 Hours (or Daily)	250 Hours	500 Hours (or Yearly)
Check Engine Air Cleaner Restriction Indicator (p45)	●		
Check Engine Oil Level (p46)	●		
Check Hydraulic Oil Level (p47)	●		
Check Tire Pressures (p52)	●		
Grease Lift Arm, Hitch and Cylinder Pivots (p44)	●		
Check Bucket Cutting Edge (p51)	●		
Check Seat and Restraint Bar Operation (p51)	●		
Check Coolant Level (p49)	●		
Clean Cooling System (p49)		●	
Check Wheel Nuts Torque (p51)	○	●	
Check Oil Level in Chaincases (p50)		●	
Clean Spark Arrestor Muffler (p51)		●	
Check Alternator/Fan Belt Tensions (p51)		●	
Change Engine Oil and Filter (p46)	□	●	
Change Hydraulic Oil Filter (p48)	□		●
Check Battery (p53)			●
Check Engine Mounting Hardware (p47)			●
Change Fuel Filter (p47)			●
Change Hydraulic Oil (p48)			◆
Change Chaincase Oil (p50)	□		◆
Drain/Flush Cooling System (p49)			●

- Perform the initial procedure at 2 hours then at “●” intervals.
- Perform the initial procedure at 50 hours then at “●” intervals.
- ◆ Perform the procedure at 1000 hours.

# Maintenance Log

<b>Date</b>	<b>Hours</b>	<b>Service Procedure</b>



# SPECIFICATIONS

## **Loader Specifications**

---

### Operating Weight

3635	4400 lb (1996 kg)
3935	4600 lb (2087 kg)

### Shipping Weight

3635	3970 lb (1801 kg)
3935	4170 lb (1892 kg)

### SAE Rated Operating Load<sup>1</sup>

3635	1050 lb (476 kg)
3935	1260 lb (572 kg)

### Engine

Make	Yanmar
Model	3TNV88
Displacement	100 in <sup>3</sup> (1.64 L)
Horsepower (net) @ 3000 rpm	36.7 hp (27.4 kW)
Peak Torque @ 1600 rpm	79 lb-ft (107 N·m)

### Hydraulic System (theoretical)

Main Hydraulic System Pressure	2750 psi (345 bar)
Standard Flow Rating	14.5 gpm (55 L/min)

### Capacities

#### Chaincase (each)

3635	4.5 U.S. gal (17 L)
3935	5.0 U.S. gal (19 L)

Engine Oil 5.0 U.S. qts (4,8 L)

Fuel Tank 8.5 U.S. gal (32,2 L)

Hydraulic Reservoir 8.0 U.S. gal (30 L)

### Sound (with Deluxe Sound Kit)

Pressure Level (Operator Ear) 85 dB(A)

Power Level (Environmental) 103 dB(A)

<sup>1</sup> Operating load rated with a 54" (1372 mm) dirt/construction bucket in accordance with SAE J818.

## Standard Features

---

- Choice of three controls: T-Bar, Dual Hand or Hand/Foot
- Fuel Gauge
- All-Tach™ Attachment System (Universal-Style)
- Warning Lights and Buzzer - Engine and Hydraulic Oil Temperature
- Manual Controlled Hydrostatic Drive
- Battery Charge Indicator Light
- ROPS/FOPS- Level II - Approved Overhead Guard
- Low Oil Pressure Light and Buzzer
- Independent Hydraulic Reservoir and Hydraulic Oil Cooler
- Foot and Hand Throttle (T-Bar and Dual Hand Units Only)
- Operator Restraint Bar With Armrests
- Engine Intake Air Pre-Heater Starting Assist (Manual)
- Hydraloc™ System - Brakes and Interlock For Starter, Lift/Tilt Cylinders, Auxiliary Hydraulics, and Wheel Drives
- Adjustable Seatbelt
- Lift Arm Support Device
- Dual Front and Rear Work Lights
- Removable Belly Plate and Access Cover
- Dual Element Air Cleaner with Visual Indicator
- Vandalism Lock Provisions
- Top and Rear Windows - ROPS
- Spark Arrestor Muffler
- Headliner and Acoustical Interior
- Seatbelt Indicator Light and Buzzer
- Adjustable Seat
- Front Auxiliary Hydraulics with 3/4" Flat-Faced Couplers
- Water Temperature Gauge (SX only)
- Hourmeter
- Number 80K Drive Chain
- Self-Leveling Lift Action (SX only)

## Accessories

---

- Audible Back-Up Alarm
- Engine Block Heater
- Horn
- Suspension Seat
- Cab Door with Wiper and Dome Light
- Sliding Side Windows
- Heater/Defroster
- Deluxe Sound Package
- 3-inch wide Seatbelt - When Required by Law
- Rear View Mirror
- Engine Auto-Shutdown System
- Interior Dome Light
- Centrifugal Pre-Cleaner
- Strobe Light
- Impact Resistant Door
- Lift Kit
- Rear Counterweight
- Battery Disconnect Switch
- Engine Coolant Temperature Gauge
- Bucket Bolt-On Cutting Edge
- Diesel Engine Exhaust Purifier
- Hydraulic Coupler - Kit
- Auxiliary Hydraulics (non-SX only)
- Self-Leveling Lift Action (non-SX only)



## Dimensional Specifications

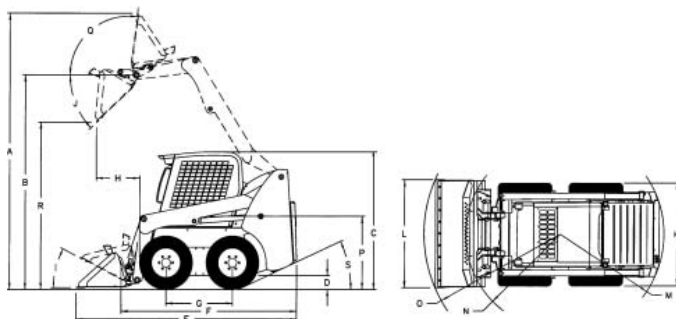

		3635		3935	
		Inches	(mm)	Inches	(mm)
<b>A</b>	Overall Operation Height - Fully Raised	139.8	(3550)	141.8	(3600)
<b>B</b>	Height to Hinge Pin - Fully Raised	108.0	(2743)	110.0	(2794)
<b>C</b>	Overall Height - Top of ROPS	70.3	(1784)	72.3	(1835)
<b>D</b>	Ground Clearance - to Chassis (Between Wheels)	6.0	(152)	8.0	(203)
<b>E</b>	Overall Length w/54" (1372 mm) Dirt/Const. Bucket	114.0	(2896)	116.0	(2946)
	Overall Length w/60" (1524 mm) Dirt/Const. Bucket	117.0	(2972)	119.0	(3023)
<b>F</b>	Overall Length (less Bucket)	88.0	(2235)	90.0	(2285)
<b>G</b>	Wheel Base	34.4	(874)	36.3	(922)
<b>H</b>	Dump Reach - w/54" (1372 mm) Dirt/Const. Bucket	22.8	(578)	20.8	(528)
	Dump Reach - w/60"(1524 mm) Dirt/Const. Bucket	-	-	25.0	(635)
<b>I</b>	Rollback at Ground	28°		28°	
<b>J</b>	Dump Angle at Full Height	42°		42°	
<b>K</b>	Overall Width - less Bucket w/27 x 8.50 x 15 HD Tires	48.3	(1226)	-	-
	Overall Width - less Bucket w/27 x 10.50 x 15 HD Tires	52.4	(1331)	52.4	(1331)
	Overall Width - less Bucket w/10.00 x 16.5 HD Tires	-	-	51.9	(1318)
<b>L</b>	Bucket Width 48" (1219 mm) Dirt/Const. Bucket - Overall	49.3	(1252)	49.3	(1252)
	Bucket Width 54" (1372 mm) Dirt/Const. Bucket - Overall	55.3	(1403)	55.3	(1403)
	Bucket Width 60" (1524 mm) Dirt/Const. Bucket - Overall	61.0	(1549)	61.0	(1549)
	Bucket Width 65" (1651 mm) Dirt/Const. Bucket-Overall	-	-	67.0	(1702)
<b>M</b>	Clearance Circle - Rear	52.9	(1344)	53.8	(1367)
<b>N</b>	Clearance Circle - Front (less Bucket)	42.0	(1067)	43.2	(1097)
<b>O</b>	Clearance Circle - Front w/54" (1372 mm) Dirt/Const. Bucket	68.7	(1745)	69.0	(1753)
	Clearance Circle - Front w/60" (1524 mm) Dirt/Const. Bucket	71.1	(1806)	71.1	(1806)
<b>P</b>	Seat to Ground Height	32.3	(819)	34.3	(870)
<b>Q</b>	Rollback at Full Height	100°		100°	
<b>R</b>	Dump Height - w/54" (1372 mm) Dirt/Const. Bucket	84.5	(2146)	86.5	(2197)
	Dump Height - w/60" (1524 mm) Dirt/Const. Bucket	-	-	86.3	(2191)
<b>S</b>	Departure Angle	23°		26°	

## Capacities and Ratings

**Note:** Use the Table of Common Materials and Densities (page 72) for selecting the appropriate bucket.

### Dirt / Construction Buckets

Description <sup>1</sup>	Part No.	Weight	3635 Rating*	3935 Rating*
54/55.5" 9.5 ft <sup>3</sup> (1372/1410 mm 0.27 m <sup>3</sup> ) with Spillguard	808248	255 lb (116 kg)	1050 lb (476 kg)	1260 lb (572 kg)
60/61.5" 10 ft <sup>3</sup> (1524/1562 mm 0.28 m <sup>3</sup> ) Low Profile	808337	300 lb (136 kg)	900 lb (408 kg)	1050 lb (476 kg)

### Utility Buckets

Description <sup>1</sup>	Part No.	Weight	3635 Rating*	3935 Rating*
48/49.5" 11.8 ft <sup>3</sup> (1372/1410 mm 0.33 m <sup>3</sup> )	808247	285 lb (129 kg)	875 lb (397 kg)	1075 lb (488 kg)
54/55.5" 13.5 ft <sup>3</sup> (1372/1410 mm 0.38 m <sup>3</sup> )	808249	290 lb (132 kg)	850 lb (386 kg)	1050 lb (476 kg)
60/61.5" 15.2 ft <sup>3</sup> (1524/1562 mm 0.43 m <sup>3</sup> )	808250	335 lb (152 kg)	800 lb (363 kg)	1000 lb (454 kg)

### Light Material/ Snow Bucket

Description <sup>1</sup>	Part No.	Weight	3635 Rating*	3935 Rating*
65/66.5" 18 ft <sup>3</sup> (1651/1689 mm 0.51 m <sup>3</sup> )	807242	400 lb (181 kg)	775 lb (352 kg)	975 lb (442 kg)

### Pallet Forks @ 24" (610 mm) Load Center (Per SAE J1197 & J1464)

Description	Part No.	Weight	3635 Rating***	3935 Rating***
48" (1219 mm) Forks with Spillguard	806841	560 lb (254 kg)	470 lb (213 kg)	570 lb (259 kg)

### Pallet Forks @ 400 mm (15.8") Load Center (Per EN 474-3)

Description	Part No.	Weight	3635 Rating**	3935 Rating**
48" (1219 mm) Forks with Spillguard	806841	560 lb (254 kg)	550 lb (249 kg)	650 lb (295 kg)

<sup>1</sup> inner/outer dimensions given

\* increase rating by 100 lb (45 kg) if weight kit is installed.

\*\* increase rating by 75 lb (34 kg) if weight kit is installed.

\*\*\* increase rating by 70 lb (32 kg) if weight kit is installed.

# Table of Common Materials and Densities

Material	Density	
	(lb/ft <sup>3</sup> )	(kg/m <sup>3</sup> )
Ashes	35-50	560-800
Brick-common	112	1792
Cement	110	1760
Charcoal	23	368
Clay, Wet-Dry	80-100	1280-1600
Coal	53-63	848-1008
Concrete	115	1840
Cinders	50	800
Coal-anthracite	94	1504
Coke	30	480
Earth-dry loam	70-90	1121-1442
Earth-wet loam	80-100	1281-1602
Granite	93-111	1488-1776
Gravel-dry	100	1602
Gravel-wet	120	1922
Gypsum-crushed	115	1840
Iron Ore	145	2320
Lime	60	960
Lime Stone	90	1440
Manure-liquid	65	1040
Manure-solid	45	720
Peat-solid	47	752
Phosphate-granular	90	1440
Potash	68	1088
Quartz-granular	110	1760
Salt-dry	100	1602
Salt-Rock-solid	135	2160
Sand-dry	108	1728
Sand-wet	125	2000
Sand-foundry	95	1520
Shale-crushed	90	1440
Slag-crushed	70	1120
Snow	15-50	240-800
Taconite	107	1712

**Note:** The densities listed are average values and intended only as a guide for bucket selection. For a material that is not in the table, obtain its density value before selecting the appropriate bucket.

To use the table, find the material name and see what its maximum density is. Then, multiply the loader rating of the attachment by the material density to determine if the attachment can safely be used. See page 71 for a listing of attachments and their loader ratings.

**Note:** *Where the material density is listed as a range (clay at 80-100 lb/ft<sup>3</sup>, for example), always use the maximum density (100 lb/ft<sup>3</sup> in this example) for making calculations. Also, see the following examples.*

**Example 1:** If clay (density of 80-100 lb/ft<sup>3</sup>) is to be hauled using a 3935 model loader using Dirt/Construction Bucket #808248, the bucket capacity is 9.5 ft<sup>3</sup> and the loader rating is 1250 lb. Multiply the density of clay (100 lb/ft<sup>3</sup>) by the capacity of the bucket (9.5 ft<sup>3</sup>) to achieve the weight being carried. (100 lb/ft<sup>3</sup> x 9.5 ft<sup>3</sup> = 950 lb) This number is less than the machine rating so you could safely use this bucket in this application.

**Example 2:** If potash (density of 68 lb/ft<sup>3</sup>) is to be hauled using a 3635 model loader using Utility Bucket #808249, the bucket capacity is 13.5 ft<sup>3</sup> and the loader rating is 850 lbs. Multiply the density of potash (68 lb/ft<sup>3</sup>) by the capacity of the bucket (13.5 ft<sup>3</sup>) to achieve the weight being carried (68 lb/ft<sup>3</sup> x 13.5 ft<sup>3</sup> = 918 lb). This number exceeds the machine rating and a counterweight will be required. With the counterweight installed, the loader rating increases to 950 lb (850 lb loader rating + 100 lb counterweight). The bucket can now be used safely in this application.

# INDEX

<b>A</b>		<b>D</b>	
Accessory Plug . . . . .	20	Dealer Services . . . . .	41
Adjustments . . . . .	44	Dual Hand Controls . . . . .	27
Control Handles . . . . .	44	Drive Control . . . . .	27
Drive Chains . . . . .	44	Lift/Tilt Control . . . . .	28
Engine Speed Control . . . . .	44		
Fuel Sender . . . . .	44	<b>E</b>	
Alternator/Fan Belt . . . . .	52	Emergency Exit . . . . .	18
Attachments . . . . .	30,35	Engine Air Cleaner . . . . .	46
Auxiliary Hydraulic Controls . . . . .	29	Engine Mounting Hardware . . . . .	47
Hand/Foot Controlled . . . . .	29	Engine Service . . . . .	47
T-Bar Controlled . . . . .	29	Change Fuel Filter . . . . .	48
		Change Oil and Filter . . . . .	48
		Check Oil . . . . .	47
<b>B</b>		Engine Speed Control . . . . .	20
Battery . . . . .	54		
Jump Starting the Battery . . . . .	34	<b>G</b>	
Bucket Cutting Edge . . . . .	52	Guards and Shields . . . . .	16
Bucket, Usage . . . . .	37		
Digging with a Bucket . . . . .	37	<b>H</b>	
Driving on an Incline . . . . .	37	Hand/Foot Controls . . . . .	25
Driving over Rough Terrain . . . . .	37	Drive Controls . . . . .	25
Dumping Into a Box . . . . .	38	Lift/Tilt Controls . . . . .	26
Dumping Onto a Pile . . . . .	38	Highway Travel . . . . .	39
Dumping the Load Over an		Hydraulic System . . . . .	49
Embankment . . . . .	38	Change Oil . . . . .	49
Leveling the Ground . . . . .	39	Change Oil Filter . . . . .	49
Loading a Bucket . . . . .	37	Check Oil Level . . . . .	49
Scraping with a Bucket . . . . .	38		
<b>C</b>			
Chaincases . . . . .	51		
Checking and Adding Oil . . . . .	51		
Draining Oil . . . . .	51		
Circuit Breakers . . . . .	54		
Cold Starting Procedure . . . . .	33		
Control/Indicator Symbols . . . . .	4		
CONTROLS and SAFETY EQUIPMENT	16		
Cooling System . . . . .	50		
Check Coolant Level . . . . .	50		
Clean . . . . .	50		
Drain/Flush . . . . .	50		
		<b>I</b>	
		Instrument Panel . . . . .	21
		INTRODUCTION . . . . .	1
		<b>L</b>	
		Lift Arm Support Device . . . . .	19
		Loader	
		Lifting . . . . .	39
		Lowering Procedure . . . . .	43
		Raising Procedure . . . . .	43
		Storing . . . . .	39
		Transporting . . . . .	40

Lubrication . . . . . 45

### M

MAINTENANCE SCHEDULE . . . . . 65  
Maintenance Log. . . . . 66,67  
Mandatory Safety Shutdown Procedure  
. . . . . 7  
Model Identification . . . . . 3

### O

OPERATION . . . . . 32  
Operator Restraint Bar. . . . . 16  
Operator's Seat . . . . . 16

### P

Parking Brake . . . . . 18  
Parking the Loader. . . . . 33

### R

Rear Window . . . . . 18  
ROPS/FOPS . . . . . 18

### S

SAFETY . . . . . 6  
Safety Decals. . . . . 10  
New Decal Application . . . . . 10  
Safety Interlock System . . . . . 17  
Testing . . . . . 17  
Safety Reminders . . . . . 7  
Self-Leveling . . . . . 36  
SERVICE . . . . . 41  
Spark Arrestor Muffler . . . . . 52  
SPECIFICATIONS . . . . . 68  
Accessories . . . . . 69  
Loader Specifications. . . . . 68  
Standard Features . . . . . 69  
Starting the Engine . . . . . 32  
Before Starting the Engine . . . . . 32  
Stopping the Loader. . . . . 33  
Switches, Seat and Restraint Bar . . . 52

### T

Table of Common Materials & Densities  
. . . . . 72

T-Bar Controls . . . . . 23  
Drive Control . . . . . 23  
Lift/Tilt Control . . . . . 24

Tires . . . . . 52  
Check Tire Pressure . . . . . 53  
Mounting Tires . . . . . 53

TORQUE SPECIFICATIONS. . . . . 76

TROUBLESHOOTING. . . . . 56

Electrical System. . . . . 56,57  
Engine . . . . . 58  
Hydraulic System . . . . . 62,63,64  
Hydrostatic System . . . . . 59,61

### W

WARRANTY . . . . . 77  
Wheel Nuts . . . . . 52

# TORQUE SPECIFICATIONS

Use these torque values when tightening hardware (excluding: locknuts, and self-tapping, thread forming and sheet metal screws) unless otherwise specified.

UNIFIED NATIONAL THREAD	GRADE 2		GRADE 5		GRADE 8	
	DRY	LUBED	DRY	LUBED	DRY	LUBED
8-32	19*	14*	30*	22*	41*	31*
8-36	20*	15*	31*	23*	43*	32*
10-24	27*	21*	43*	32*	60*	45*
10-32	31*	23*	49*	36*	68*	51*
1/4-20	66*	50*	9	75*	12	9
1/4-28	76*	56*	10	86*	14	10
5/16-18	11	9	17	13	25	18
5/16-24	12	9	19	14	25	20
3/8-16	20	15	30	23	45	35
3/8-24	23	17	35	25	50	35
7/16-14	32	24	50	35	70	55
7/16-20	36	27	55	40	80	60
1/2-13	50	35	75	55	110	80
1/2-20	55	40	90	65	120	90
9/16-12	70	55	1120	80	150	110
9/16-18	80	60	120	90	170	130
5/8-11	100	75	150	110	220	170
5/8-18	110	85	180	130	240	180
3/4-10	175	130	260	200	380	280
3/4-16	200	150	300	220	420	320
7/8-9	170	125	430	320	600	460
7/8-14	180	140	470	360	660	500
1-8	250	190	640	480	900	680
1-12	270	210	710	530	1000	740

METRIC COARSE THREAD	GRADE 8.8		GRADE 10.9		GRADE 12.9	
	DRY	LUBED	DRY	LUBED	DRY	LUBED
<b>M6-1</b>	8	6	11	8	13.5	10
<b>M8-1.25</b>	19	14	27	20	32.5	24
<b>M10-1.5</b>	37.5	28	53	39	64	47
<b>M12-1.75</b>	65	48	91.5	67.5	111.5	82
<b>M14-2</b>	103.5	76.5	145.5	108	176.5	131
<b>M16-2</b>	158.5	117.5	223.5	165.5	271	200

\*All Torque Values are in ft-lbs except those marked with an \* which are in in-lbs.

For metric torque value (N·m) multiply ft-lbs value by 1.355 or the in-lbs value by 0.113.

# GEHL CONSTRUCTION WARRANTY

GEHL CONSTRUCTION DIVISION of the GEHL COMPANY, hereinafter referred to as Gehl, warrants new Gehl construction equipment to the Original Retail Purchaser to be free from defects in material and workmanship for a period of twelve (12) months from the Warranty Start Date, except as set forth below.

## **GEHL CONSTRUCTION WARRANTY SERVICE INCLUDES:**

Genuine Gehl parts and labor costs required to repair or replace equipment at the selling dealer's business location.

---

**GEHL MAKES NO REPRESENTATIONS OR WARRANTIES OF ANY KIND, EXPRESS OR IMPLIED (INCLUDING THE IMPLIED WARRANTIES OF MERCHANTABILITY AND FITNESS FOR PARTICULAR PURPOSE), EXCEPT AS EXPRESSLY STATED IN THIS WARRANTY STATEMENT.**

---

## **GEHL WARRANTY SERVICE DOES NOT INCLUDE:**

1. Transportation to selling dealer's business location or, at the option of the Original Retail Purchaser, the cost of a service call.
2. Used equipment.
3. Components covered by their own non-Gehl warranties, such as tires, trade accessories and engines.
4. Normal maintenance service and expendable, wear-out items.
5. Repairs or adjustments caused by: improper use; failure to follow recommended maintenance procedures; use of unauthorized parts or attachments; accident or other casualty.
6. Liability for incidental or consequential damages of any type, including, but not limited to lost profits and expenses of acquiring replacement equipment.

No agent, employee or representative of Gehl has any authority to bind Gehl to any warranty except as specifically set forth herein. Any of these limitations excluded by local law shall be deemed deleted from this warranty; all other terms will continue to apply.



**WRONG**

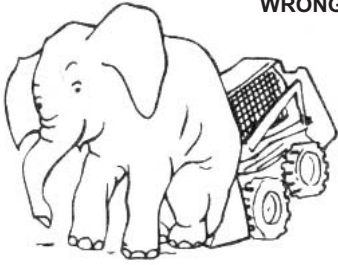

**! Never exceed rated operating load.**

**WRONG**

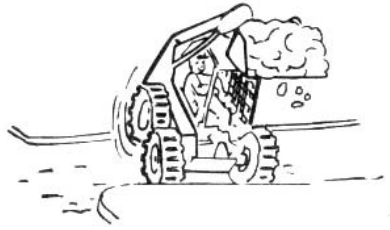

**! Always carry attachments as low as possible. Do not travel or turn with the lift arms raised. Load, unload and turn on flat level**

**WRONG**



**! Never carry riders.**

**WRONG**



**! Never modify equipment.**

**! Keep bystanders away from work area.**

**! Use only attachments approved for this model loader.**

**WRONG**

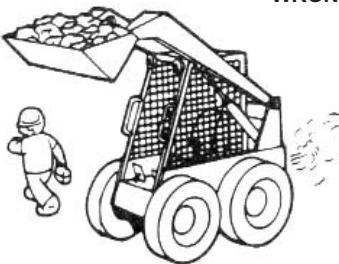

**! Never leave loader with engine running or with lift arm up. To park, engage parking brake and put attachment flat on the ground.**



**THIS OPERATOR'S MANUAL IS  
PROVIDED FOR OPERATOR USE**

**DO NOT REMOVE FROM THIS MACHINE**

**Do not start, operate or work on this machine until you carefully read and thoroughly understand the contents of this operator's manual.**

**Failure to follow safety, operating and maintenance instructions can result in serious injury to the operator or bystanders, poor operation, and costly breakdowns.**

**If you have any questions on proper operation, adjustment or maintenance of this machine, contact your dealer or the Gehl Company Service Department before starting or continuing operation.**

**California Proposition 65 Warning**

Diesel engine exhaust and some of its constituents are known to the State of California to cause cancer and birth defects or other reproductive harm.

Battery posts, terminals and related accessories contain lead and lead compounds, chemicals known to the State of California to cause cancer and birth defects or other reproductive harm. Wash hands after handling battery.

**GEHL**®

**Gehl Company** 143 Water Street, P.O. Box 179, West Bend, WI 53095-0179 U.S.A.