

SPECIFICATIONS SHEET - DAEWOO MEGA250-V

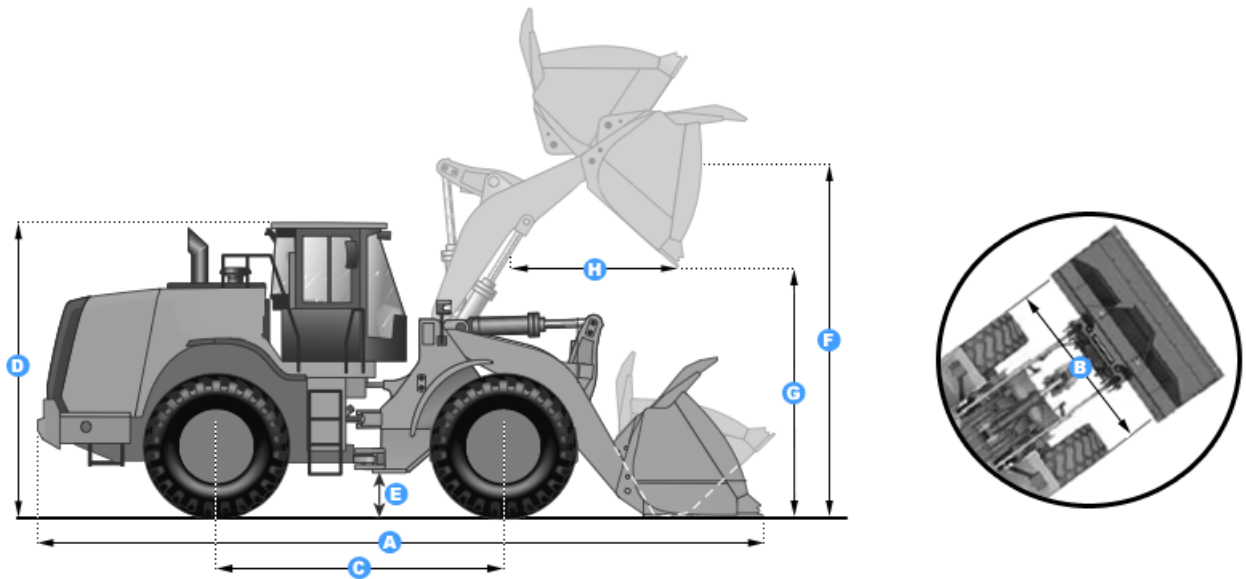

Dimensions

A: Length with Bucket: 7500 mm

B: Width Over Tires: 2563 mm

C: Wheelbase: 3020 mm

D: Height to Top of Cab: 3320 mm

E: Ground Clearance: 430 mm

F: Hinge Pin - Max Height: 3890 mm

G: Dump Clearance: 2760 mm

H: Reach at Max Lift: 1160 mm

Engine

Make: Daewoo

Model: D1146T

Net Power: 152.9 hp (114 kw)

Gross Power: 162.3 hp (121 kw)

Power Measured @: 2200 rpm

Displacement: 5.8 L

Max Torque: 736 Nm

Aspiration: Turbocharged

Operational

Operating Weight: 14000 kg

Fuel Capacity: 270 L

Hydraulic System Capacity: 195 L

Engine Oil Fluid Capacity: 21 L

Cooling System Fluid Capacity: 50 L

Transmission Fluid Capacity: 27 L

Front Axle/Diff Fluid Capacity: 31 L

Rear Axle/Diff Fluid Capacity: 24 L

Static Tipping Weight: 12000 kg

Turning Radius: 6051 mm

Operating Voltage: 24 V

Alternator Supplied Amperage: 60 amps

Rear Axle Oscillation: 22 degrees

Tire Size: 20.5-25-16PR

Transmission

Type: Full power shift

Forward Gears: 4

Reverse Gears: 3

Max Speed (Forward): 37 km/h

Max Speed (Reverse): 24.5 km/h

Hydraulic System

Pump Type: Tandem vane pumps

Relief Valve Pressure: 2900.8 psi (20000 kPa)

Pump Flow Capacity: 250 L/min

Raise Time: 5.3 sec

Dump Time: 1.2 sec

Lower Time: 3.3 sec

Bucket Specs

Breakout Force: 129.5 kN

Dump Clearance: 2760 mm

Bucket Width: 2740 mm

Bucket Capacity (Heaped): 2.4 m³