

# Operation & Maintenance Manual

HYDRAULIC  
EXCAVATOR

***PC88MR-10***

SERIAL NUMBERS 8313 and up

**⚠ WARNING**

Unsafe use of this machine may cause serious injury or death. Operators and maintenance personnel must read this manual before operating or maintaining this machine. This manual should be kept near the machine for reference and periodically reviewed by all personnel who will come into contact with it.

**NOTICE**

Komatsu has Operation & Maintenance Manuals written in some other languages. If a foreign language manual is necessary, contact your local distributor for availability.

**KOMATSU**

# FOREWORD

## **WARNING**

**Komatsu recommends that any service parts used for maintenance, repair or replacement of emission control systems be genuine new Komatsu or Komatsu approved rebuilt parts or assemblies or others parts of equivalent quality, and that the engine be serviced by an authorized Komatsu distributor. Failure to follow these recommendations could result in ineffective service, damage to the product or safety risks (including personal injury or death).**

---

# READ THIS MANUAL

This manual gives details of the operation and methods of inspection and maintenance for this machine that must be obeyed in order to use the machine safely. Most accidents are caused by the failure to follow fundamental safety rules for the operation and maintenance of machines.

Read, understand and follow all precautions and warnings in this manual and on the machine before performing operation and maintenance. Failure to do so may result in serious injury or death.

Komatsu cannot predict every circumstance that might involve a potential hazard when the machine is used. Therefore, the safety messages in this manual and on the machine may not include all possible safety precautions.

If you perform any operation, inspection, or maintenance under conditions that are not described in this manual, understand that it is your responsibility to take the necessary precautions to ensure safety. In no event should you or others engage in the prohibited uses or actions described in this manual. It is dangerous to perform improper operation and maintenance of the machine. It may cause serious injury or death.

If you sell the machine, be sure to give this manual to the new owner together with the machine.

Always keep this Operation and Maintenance Manual in the storing location so that all relevant personnel can read it at any time.

Keep it in the magazine box on the left side of the operator's seat.

If this manual is lost or damaged, contact Komatsu or your Komatsu distributor and tell them about the machine model name and the serial No. immediately to arrange for its replacement.

For details regarding the machine model name and the serial No., see the machine serial No. plate. In order to arrange the proper Operation and Maintenance Manual, you will need to provide the machine model name and the serial No.

This manual uses the International System of Units (SI) for units of measurement. For reference, units that have been used in the past are given in { }.

The explanations, values, and illustrations in this manual have been prepared based on the latest information available as of the date of its publication. Continuing improvements in the design of this machine may lead to additional changes that are not reflected in this manual. Consult Komatsu or your Komatsu distributor for the latest available information concerning your machine or with questions regarding information contained in this manual.

The numbers in the illustrations correspond to the numbers in ( ) in the text. (Example: 1 → (1))

Komatsu delivers machines that comply with all applicable regulations and standards of the country to which it has been shipped. If this machine has been purchased in another country, it may lack certain safety devices and specifications that are necessary for use in your country. If there is any question about whether your product complies with the applicable standards and regulations of your country, consult your Komatsu distributor before operating the machine.

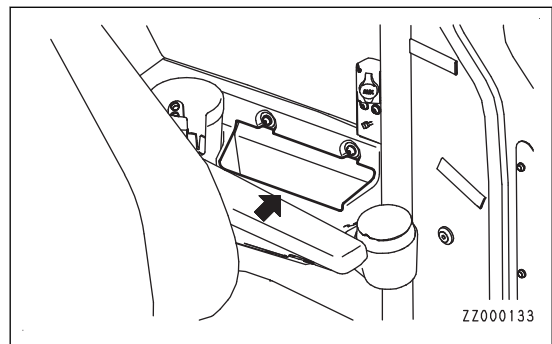

## SAFETY INFORMATION

To enable you to use the machine safely, and to prevent personal injury to operators, service personnel or bystanders, the precautions and warnings included in this manual and the safety signs attached to the machine must always be observed.

To identify important safety messages in the manual and on the machine labels, the following signal words are used.

The "Safety Alert Symbol" identifies important safety messages on machines, in manuals, and elsewhere. When you see this symbol, be alert to the risk of personal injury or death. Follow the instructions in the safety message.

**DANGER**

This signal word indicates an imminently hazardous situation which, if not avoided, will result in death or serious injury.

**WARNING**

This signal word indicates a potentially hazardous situation which, if not avoided, could result in death or serious injury.

**CAUTION**

This signal word indicates a potentially hazardous situation which, if not avoided, may result in minor or moderate injury. It may also be used to alert against unsafe practices that may cause property damage.

The following signal words are used to alert you to information that must be followed to avoid damage to the machine.

**NOTICE**

If precautions described are not observed, the machine may be damaged or the service life may be reduced.

**REMARK**

This word is used for information that is useful to know.



# INTRODUCTION

## MAIN USE OF MACHINE

This Komatsu machine is designed to be used mainly for the following work:

- Digging work
- Ditching work
- Loading work
- Leveling work
- Demolition work

For details of work procedure, see OPERATION, "RECOMMENDED APPLICATIONS".

## DIRECTIONS OF MACHINE

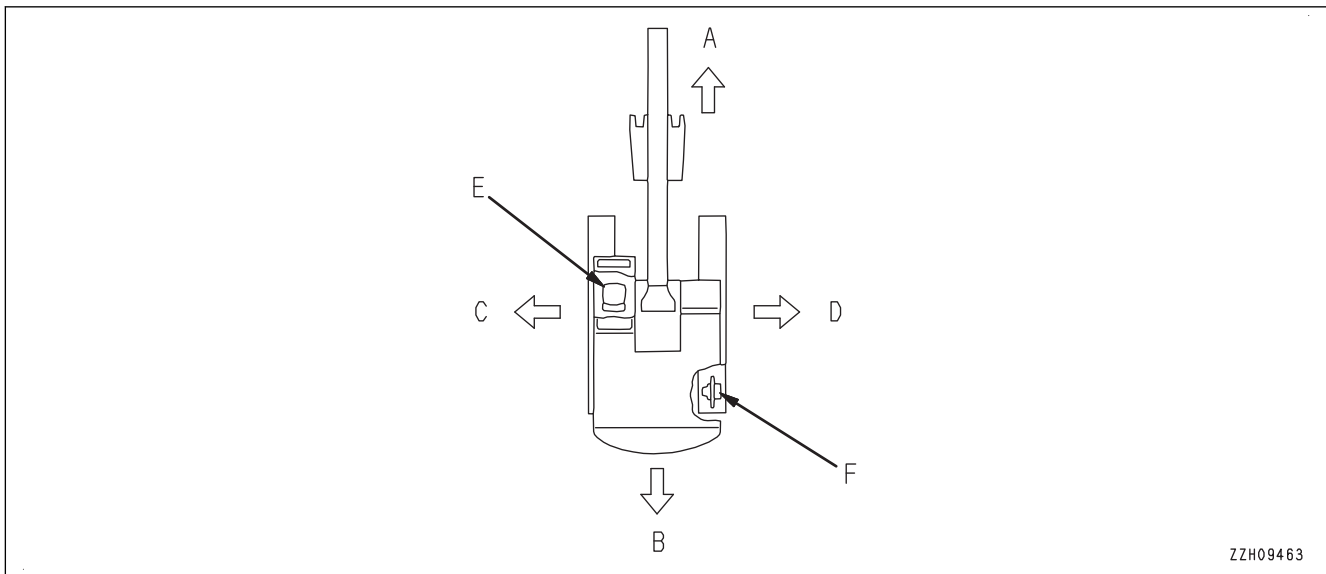

(A) Front

(B) Rear

(C) Left

(D) Right

(E) Operator's seat

(F) Sprocket

In this manual, the terms front, rear, left, and right refer to the travel direction as seen from the operator's seat when the operator's seat is facing the front and the sprocket is at the rear of the machine.

### VISIBILITY FROM OPERATOR'S SEAT

The visibility of this machine required by visibility standards (ISO 5006) are shown in the drawing below.

#### Proximity visibility

The figure below shows a visibility from the machine at a spot 1.0 m (3 ft 3 in) away from outside the machine and 1.5 m (4 ft 11 in) above the ground.

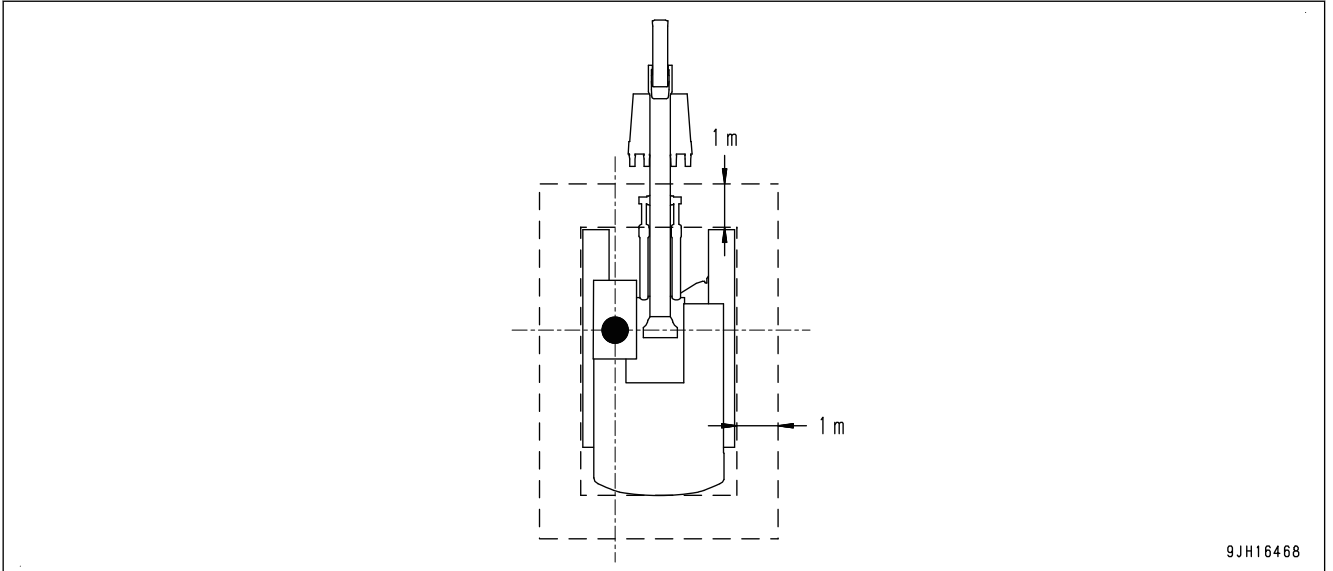

#### 12 m circumference visibility

The figure below shows a visibility from the machine for a circumference of 12 m (39 ft 4 in). Shaded areas (A), (B), and (C) in the figure show areas, the views of which are blocked when the machine is equipped with the mirrors and other visibility assistant devices. Be fully aware that there is an area where the operator cannot see when operating the machine.

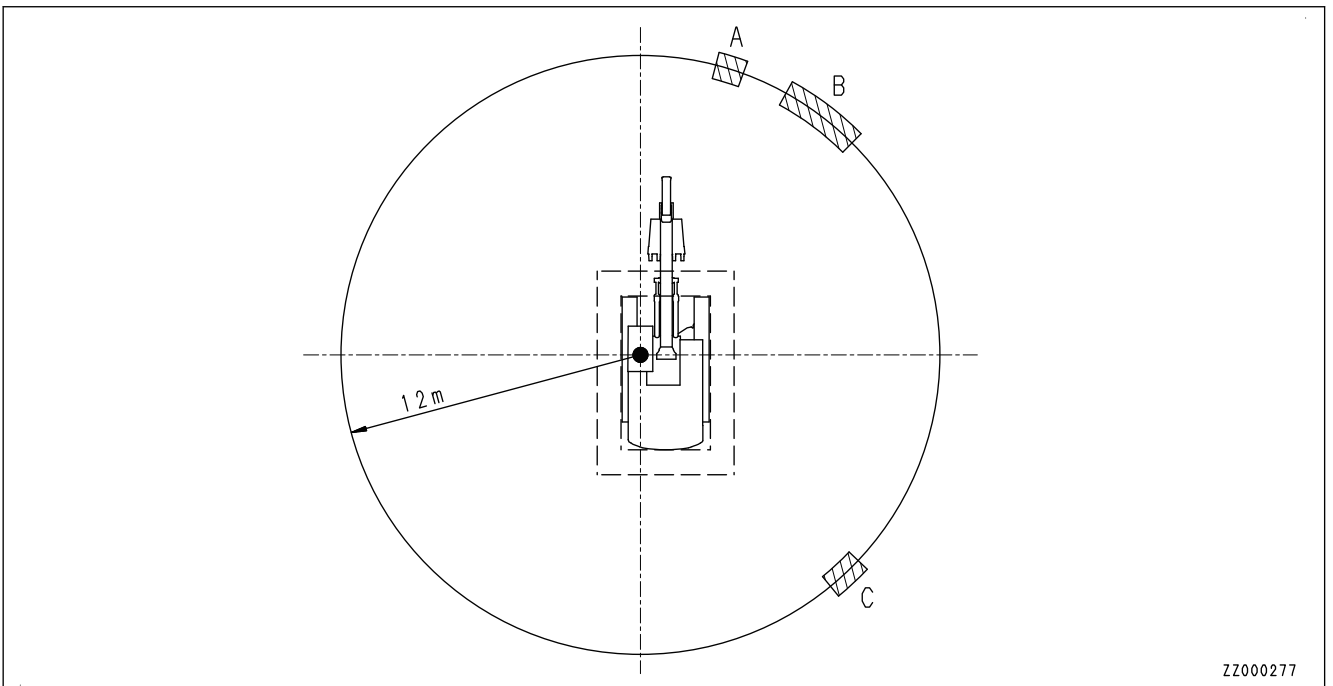

#### Protective structures

This machine is equipped with a structure to protect the operator conforming to ISO12117-2: 2008.

## PRODUCT INFORMATION

When requesting service or ordering replacement parts, inform your Komatsu distributor of the following items.

### LOCATION OF PRODUCT IDENTIFICATION NUMBER (PIN)/MACHINE SERIAL NO. PLATE

This is on the left side of the mounting location of the swing bracket.

The design of the nameplate differs according to the district.

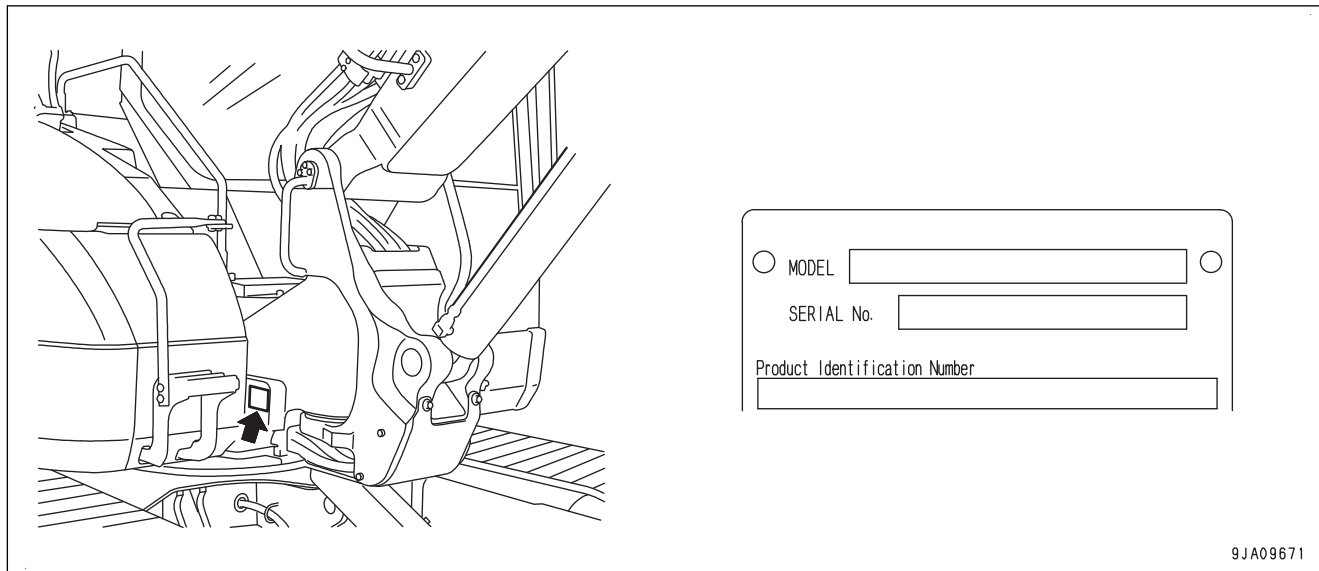

### LOCATION OF ENGINE NUMBER PLATE

This is on the side of the filler port bracket.

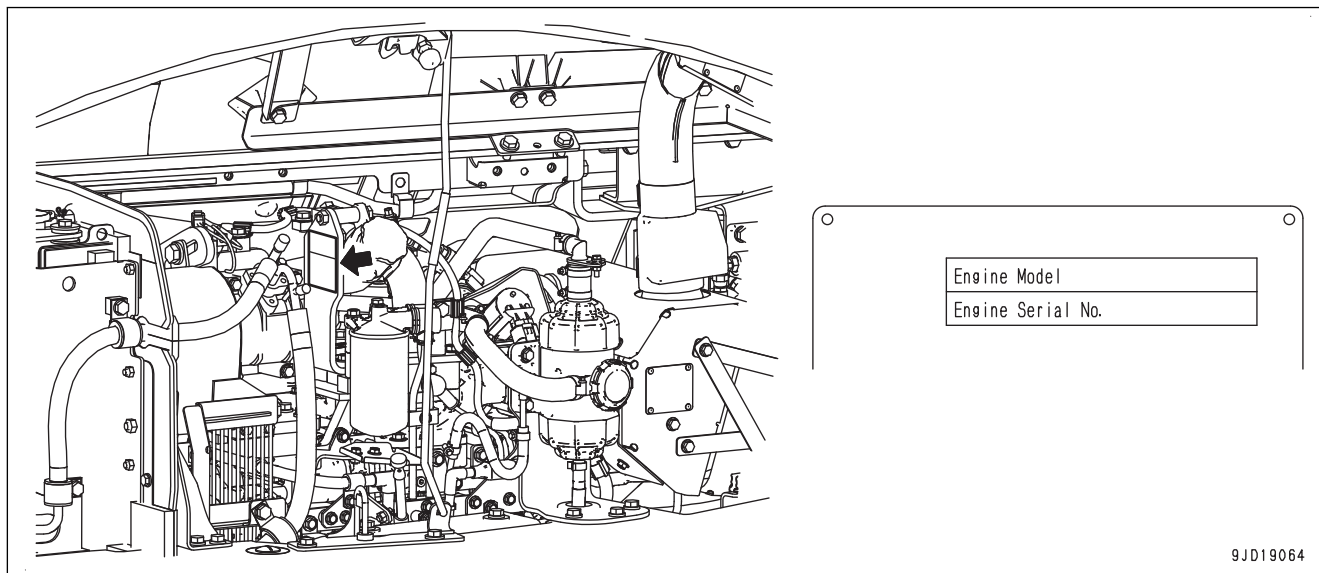

## SERVICE METER LOCATION

This is displayed on the machine monitor.

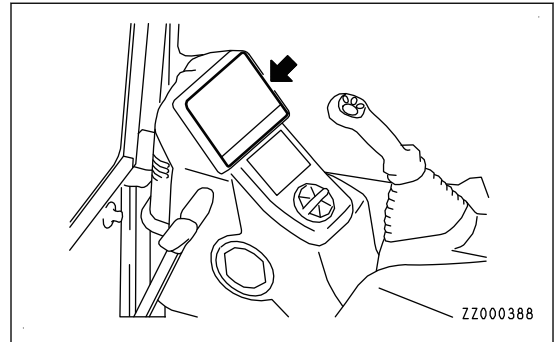

## YOUR MACHINE SERIAL NUMBERS AND DISTRIBUTOR

Machine serial No.	
Engine serial No.	
Product identification number (PIN)	
Distributor name	
Address	
Phone/Fax	
Service personnel	

# TABLE OF CONTENTS

FOREWORD.....	1-1
READ THIS MANUAL.....	1-2
SAFETY INFORMATION.....	1-3
INTRODUCTION.....	1-4
MAIN USE OF MACHINE.....	1-4
DIRECTIONS OF MACHINE.....	1-4
VISIBILITY FROM OPERATOR'S SEAT.....	1-5
PRODUCT INFORMATION.....	1-6
LOCATION OF PRODUCT IDENTIFICATION NUMBER (PIN)/MACHINE SERIAL NO. PLATE.....	1-6
LOCATION OF ENGINE NUMBER PLATE.....	1-6
SERVICE METER LOCATION.....	1-7
YOUR MACHINE SERIAL NUMBERS AND DISTRIBUTOR.....	1-7
SAFETY.....	2-1
SAFETY LABELS.....	2-2
LOCATION OF SAFETY LABELS.....	2-3
CONTENTS OF SAFETY LABELS.....	2-5
GENERAL PRECAUTIONS COMMON TO OPERATION AND MAINTENANCE.....	2-14
PRECAUTIONS BEFORE STARTING OPERATION.....	2-14
PREPARATIONS FOR SAFE OPERATION.....	2-14
PRECAUTIONS TO PREVENT FIRE.....	2-16
PRECAUTIONS WHEN GETTING ON OR OFF MACHINE.....	2-18
DO NOT GET CAUGHT IN WORK EQUIPMENT.....	2-19
PRECAUTIONS RELATED TO PROTECTIVE STRUCTURES.....	2-20
PROTECTION AGAINST FALLING, FLYING OR INTRUDING OBJECTS.....	2-20
UNAUTHORIZED MODIFICATION.....	2-21
PRECAUTIONS RELATED TO ATTACHMENTS AND OPTIONS.....	2-21
PRECAUTIONS RELATED TO CAB GLASS.....	2-21
PRECAUTIONS WHEN RUNNING ENGINE INSIDE BUILDING.....	2-21
PRECAUTIONS FOR OPERATION.....	2-22
PRECAUTIONS FOR JOBSITE.....	2-22
START ENGINE.....	2-24
PRECAUTIONS FOR OPERATION.....	2-26
PRECAUTIONS FOR TRANSPORTATION.....	2-34
TOWING AND BEING TOWED.....	2-35
LIFTING OPERATION BY USING BUCKET WITH HOOK.....	2-36
PRECAUTIONS FOR MAINTENANCE.....	2-37
PRECAUTIONS BEFORE STARTING INSPECTION AND MAINTENANCE.....	2-37
PRECAUTIONS FOR CHECK AND MAINTENANCE.....	2-40
OPERATION.....	3-1
GENERAL VIEW.....	3-2
MACHINE EQUIPMENT NAME.....	3-2
CAB EQUIPMENT NAMES.....	3-4
CONTROLS AND GAUGES NAMES.....	3-5
EXPLANATION OF COMPONENTS.....	3-8
EXPLANATION OF MACHINE MONITOR EQUIPMENT.....	3-8
SWITCHES.....	3-81
CONTROL LEVERS AND PEDALS.....	3-89
OTHER EQUIPMENT.....	3-94
MACHINE OPERATIONS AND CONTROLS.....	3-116
CHECKS AND ADJUSTMENT BEFORE STARTING ENGINE.....	3-116
METHOD FOR STARTING ENGINE.....	3-139
METHOD FOR OPERATIONS AND CHECKS AFTER STARTING ENGINE.....	3-144
METHOD FOR STOPPING ENGINE.....	3-155
METHOD FOR STARTING MACHINE (TRAVEL FORWARD AND REVERSE) AND STOPPING MACHINE.....	3-156
METHOD FOR STEERING MACHINE.....	3-160

METHOD FOR SWINGING MACHINE .....	3-162
METHOD FOR OPERATING WORK EQUIPMENT .....	3-162
HANDLE WORKING MODE .....	3-164
PROHIBITED OPERATIONS .....	3-166
PRECAUTIONS FOR OPERATION .....	3-171
PRECAUTIONS FOR WORKING ON SLOPE .....	3-173
METHOD FOR ESCAPING FROM MUD .....	3-175
RECOMMENDED APPLICATIONS .....	3-176
METHOD FOR REPLACING AND INVERTING BUCKET .....	3-178
METHOD FOR PARKING MACHINE .....	3-181
METHOD FOR CHECKING AFTER FINISHING WORK .....	3-182
LOCK .....	3-183
HANDLE AIR CONDITIONER .....	3-192
EXPLANATION OF AIR CONDITIONER EQUIPMENT .....	3-193
METHOD FOR OPERATING AIR CONDITIONER .....	3-198
HANDLE RADIO .....	3-205
EXPLANATION OF RADIO EQUIPMENT .....	3-205
METHOD FOR CONTROLLING RADIO .....	3-208
STOW ANTENNA .....	3-210
HANDLE ROAD LINERS AND RUBBER SHOES .....	3-211
RECOMMENDED USE OF ROAD LINERS AND RUBBER SHOES .....	3-211
WARRANTY OF ROAD LINERS AND RUBBER SHOES .....	3-211
PRECAUTIONS WHEN USING ROAD LINERS AND RUBBER SHOES .....	3-212
TRANSPORTATION .....	3-215
PRECAUTIONS FOR TRANSPORTING MACHINE .....	3-215
SELECT TRANSPORTATION METHOD .....	3-215
LOADING AND UNLOADING WITH TRAILER .....	3-216
METHOD FOR LIFTING MACHINE .....	3-222
COLD WEATHER OPERATION .....	3-224
COLD WEATHER OPERATION INFORMATION .....	3-224
PRECAUTIONS AFTER DAILY WORK COMPLETION IN COLD WEATHER .....	3-225
AFTER COLD WEATHER SEASON .....	3-225
PRECAUTIONS FOR LONG-TERM STORAGE .....	3-226
PREPARATION FOR LONG-TERM STORAGE .....	3-226
MAINTENANCE DURING LONG-TERM STORAGE .....	3-226
STARTING MACHINE AFTER LONG-TERM STORAGE .....	3-227
TROUBLES AND ACTIONS .....	3-228
ACTIONS WHEN RUNNING OUT OF FUEL .....	3-228
PHENOMENA THAT ARE NOT FAILURES .....	3-229
PRECAUTIONS FOR TOWING MACHINE .....	3-230
PRECAUTIONS FOR SEVERE JOB CONDITION .....	3-230
PRECAUTIONS FOR DISCHARGED BATTERY .....	3-231
OTHER TROUBLE .....	3-237
MAINTENANCE .....	4-1
PRECAUTIONS FOR MAINTENANCE .....	4-2
CHECK SERVICE METER READING .....	4-2
KOMATSU GENUINE REPLACEMENT PARTS .....	4-2
KOMATSU GENUINE LUBRICANTS .....	4-2
ALWAYS USE CLEAN WASHER FLUID .....	4-2
FRESH AND CLEAN LUBRICANTS .....	4-2
CHECK DRAINED OIL AND USED FILTER .....	4-2
PRECAUTIONS FOR REFILLING OIL OR FUEL .....	4-2
PRECAUTIONS FOR WELDING .....	4-2
DO NOT DROP THINGS INSIDE MACHINE .....	4-2
DUSTY JOBSITES .....	4-3
AVOID MIXING OIL .....	4-3
LOCK INSPECTION COVERS .....	4-3
BLEED AIR FROM HYDRAULIC CIRCUIT .....	4-3

PRECAUTIONS WHEN INSTALLING HYDRAULIC HOSES .....	4-3
CHECKS AFTER INSPECTION AND MAINTENANCE.....	4-3
FUEL AND LUBRICANTS TO MATCH THE AMBIENT TEMPERATURE.....	4-3
OUTLINE OF MAINTENANCE.....	4-4
HANDLE OIL, FUEL, COOLANT, AND PERFORMING OIL CLINIC .....	4-4
HANDLE ELECTRICAL COMPONENTS .....	4-7
STANDARD TIGHTENING TORQUE FOR BOLTS AND NUTS .....	4-8
MAINTENANCE SCHEDULE.....	4-10
MAINTENANCE SCHEDULE TABLE.....	4-10
MAINTENANCE INTERVAL FOR HYDRAULIC BREAKER .....	4-11
MAINTENANCE INTERVAL WHEN DIESEL FUEL MIXED WITH BIO-FUEL IS USED .....	4-12
MAINTENANCE PROCEDURE .....	4-13
WHEN REQUIRED .....	4-13
CHECKS BEFORE STARTING.....	4-53
EVERY 100 HOURS MAINTENANCE .....	4-54
EVERY 250 HOURS MAINTENANCE .....	4-56
EVERY 500 HOURS MAINTENANCE .....	4-62
EVERY 1000 HOURS MAINTENANCE .....	4-75
EVERY 2000 HOURS MAINTENANCE .....	4-83
EVERY 4000 HOURS MAINTENANCE .....	4-91
EVERY 5000 HOURS MAINTENANCE .....	4-94
SPECIFICATIONS .....	5-1
SPECIFICATIONS .....	5-2
ATTACHMENTS AND OPTIONS .....	6-1
GENERAL PRECAUTIONS .....	6-2
HANDLE BUCKET WITH HOOK.....	6-4
PRECAUTIONS FOR OPERATION .....	6-4
HANDLE MACHINE READY FOR INSTALLATION OF ATTACHMENT .....	6-5
EXPLANATION OF COMPONENTS.....	6-5
HYDRAULIC CIRCUIT.....	6-7
METHOD FOR REMOVING AND INSTALLING ATTACHMENT .....	6-8
METHOD FOR OPERATING ATTACHMENT.....	6-13
LONG-TERM STORAGE .....	6-16
SPECIFICATIONS .....	6-16
METHOD FOR CHANGING CONTROL PATTERNS (FOR MACHINES EQUIPPED WITH OPERATION PATTERN CHANGE-OVER VALVE).....	6-17
CONTROL PATTERNS OTHER THAN STANDARD CONTROL METHOD .....	6-19
HANDLE POWER ANGLE BLADE .....	6-20
BLADE CONTROL LEVER .....	6-20
WHEN REQUIRED .....	6-21
EVERY 500 HOURS MAINTENANCE .....	6-21
CONSUMABLE PARTS .....	6-22
SPECIFICATIONS .....	6-22
ATTACHMENTS AND OPTIONS .....	6-23
INSTALL ATTACHMENT.....	6-23
TRACK SHOES SELECTION .....	6-25
RECOMMENDED ATTACHMENT OPERATIONS.....	6-26
HYDRAULIC BREAKER .....	6-26
BREAKERS .....	6-31
MACHINES NOT EQUIPPED WITH REAR VIEW CAMERA .....	6-34
MACHINE MONITOR EQUIPMENT NAME.....	6-34
EXPLANATION OF MACHINE MONITOR EQUIPMENT .....	6-35
REPLACEMENT PARTS.....	7-1
PERIODIC REPLACEMENT OF DEFINED LIFE PARTS.....	7-2
DEFINED LIFE PARTS LIST.....	7-2
CONSUMABLE PARTS .....	7-3
CONSUMABLE PARTS LIST .....	7-3
RECOMMENDED FUEL, COOLANT, AND LUBRICANT .....	7-4

LUBRICATION CHART ..... 7-4  
METHOD FOR USING FUEL, COOLANT AND LUBRICANTS ACCORDING TO AMBIENT TEMPERATURE ..... 7-6  
RECOMMENDED BRANDS AND QUALITIES OTHER THAN KOMATSU GENUINE OILS ..... 7-7  
INDEX..... 8-1





# SAFETY

## WARNING

**Please read and make sure that you fully understand the precautions described in this manual and the safety labels on the machine. When operating or servicing the machine, always follow these precautions strictly.**

---

## SAFETY LABELS

### **WARNING**

**Be sure that you fully understand the correct position, content and how to avoid a danger shown in the safety labels.**

Handle the warning signs and safety labels used on this machine as follows.

- Always keep the safety labels clean so that you can read it properly. When cleaning the safety labels, do not use organic solvents or gasoline. These may cause the labels to peel off.
- If the safety labels are damaged, lost, or cannot be read properly, replace them with new ones. For details of the part numbers for the safety labels, see this manual or the actual label, and place an order to your Komatsu distributor.
- There are also other labels in addition to the warning signs and safety labels. Handle those labels in the same way.

### LOCATION OF SAFETY LABELS

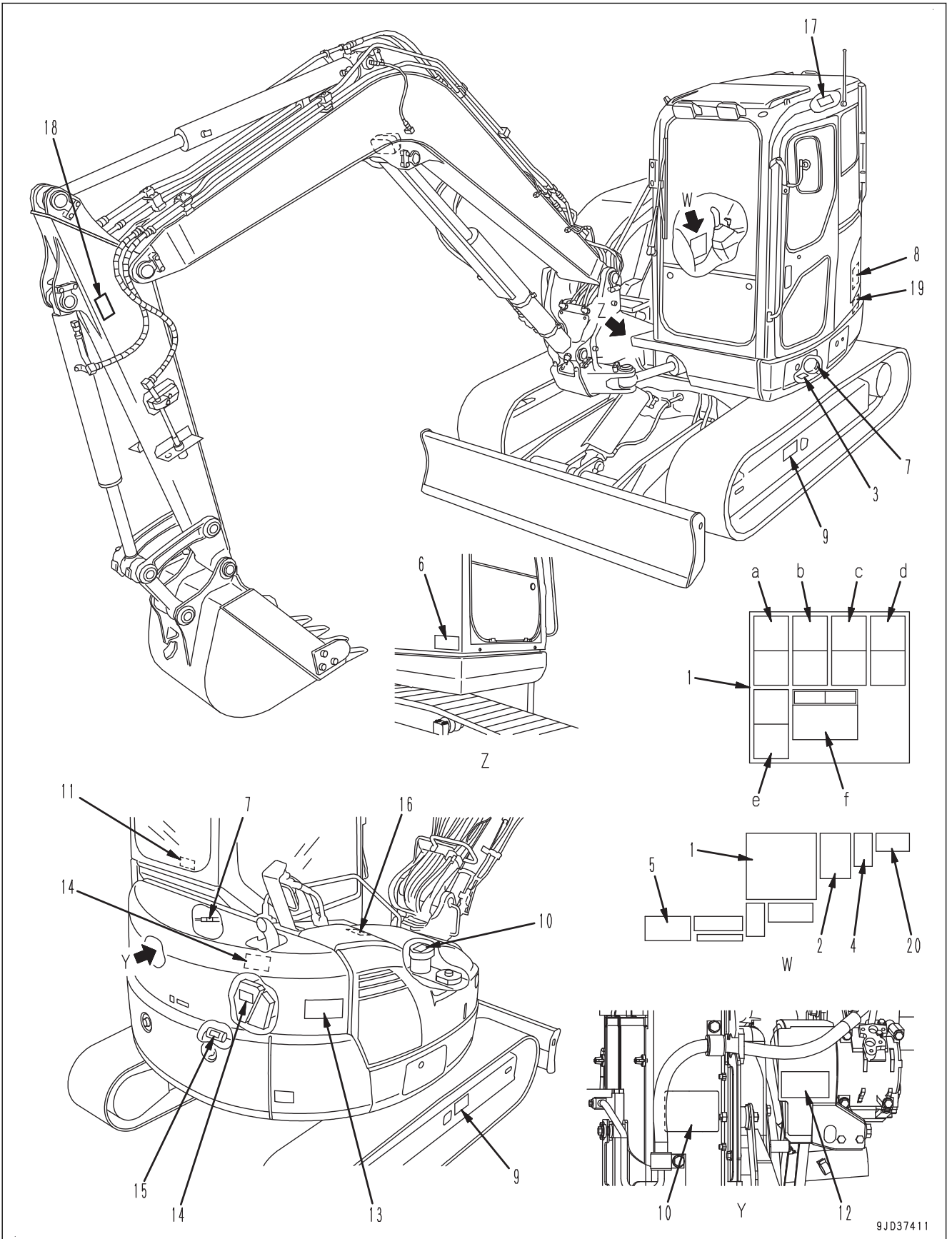

(1) Combined safety information label

(a) Warning when leaving the operator's seat

- 
- (b) Warning for operation, inspection and maintenance
  - (c) Caution when standing in operator cab
  - (d) Warning against high-voltage cable
  - (e) Warning when reversing
  - (f) Control levers operational function diagram
  - (2) Caution for control pattern
  - (3) Caution when changing control pattern
  - (4) Warning when swinging or travelling in reverse
  - (5) Warning for quick coupler system
  - (6) Warning for handling ROPS
  - (7) Caution for handling accumulator and gas spring
  - (8) Caution for handling cable
  - (9) Caution for adjusting track tension
  - (10) Caution for high temperature coolant and hydraulic oil
  - (11) Emergency escape
  - (12) Caution stop rotation during inspection and maintenance
  - (13) Danger do not enter within swing range
  - (14) Caution for high-temperature
  - (15) Caution do not start by short-circuiting
  - (16) Caution against falling
  - (17) Caution when stowing front window
  - (18) Caution for work equipment
  - (19) Caution for handling battery
  - (20) Caution for blast jobsite

## CONTENTS OF SAFETY LABELS

### (1) Combined safety information label

(22P-00-21670)

- Warnings for operation, inspection and maintenance.
- Improper operation and maintenance can cause serious injury or death.
- Read the manual and labels before operation and maintenance.

Follow instructions and warnings in manual and in labels on machine.

Detailed explanations of the content of each label are as follows:

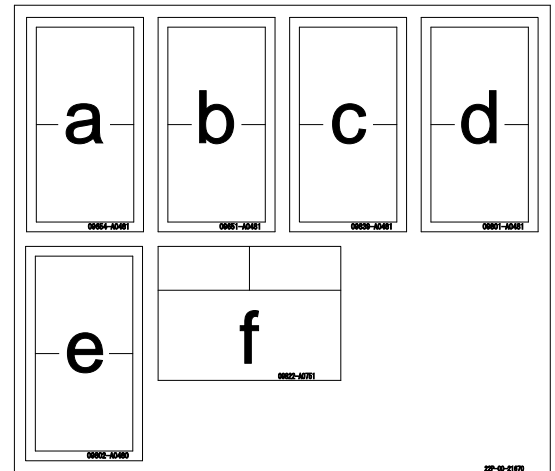

#### (a) Warning when leaving the operator's seat

(09654-A0481)

- Before standing up from operator's seat.
- Lower the work equipment to the ground and move safety lock lever (located near seat) to lock position to avoid hitting unlocked operation levers.
- Sudden and unwanted machine movement can cause serious injury or death.



#### (b) Warning for operation, inspection and maintenance

(09651-A0481)

- Warning
- Read the manual before operating, inspection, maintenance, disassembly, assembly and transportation.



**(c) Caution when standing in operator cab**

(09839-A0481)

- Take care when standing in the operator cab.
- Before standing up from the operator's seat (such as when opening or closing the front window, or when removing or installing the bottom window, or when adjusting the operator's seat), always lower the work equipment completely to the ground, set lock lever (1) securely to the LOCK position (L), then stop the engine. If you accidentally touch the control levers (pedals) when they are not locked, there is a hazard that the machine may suddenly move and cause serious injury or property damage.

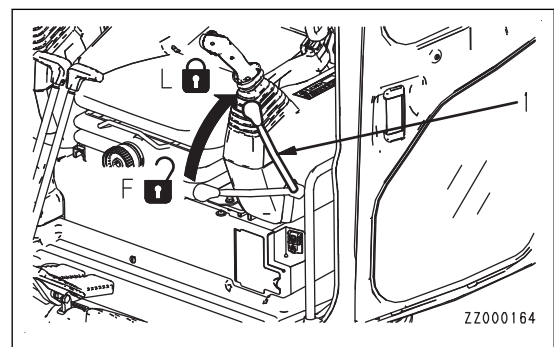
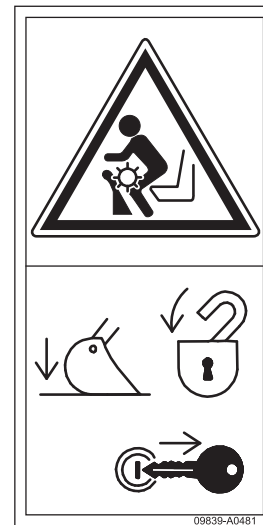
**(d) Warning against high-voltage cable**

(09801-A0481)

- An electrocution hazard if the machine is brought too near to electric power lines.
- Keep a safe distance from electric power lines.



**(e) Warning when reversing**

(09802-A0480)

To prevent SEVERE INJURY or DEATH, do the following before moving machine or its attachments:

- Sound horn to alert people nearby.  
Be sure no one is on or near machine or in swing area.  
Rotate cab for full view of travel path if it can be done safely.  
Use spotter if view is obstructed.  
Follow the above even if machine is equipped with travel alarm, mirrors and rear view camera.

**⚠ WARNING**

To open or close the front or ceiling window, never stand up from the operator's seat before throwing the safety lock lever to the lock position. Inadvertently touching any of the working equipment control levers might cause the machine to start moving all of a sudden, probably resulting in a serious injury.

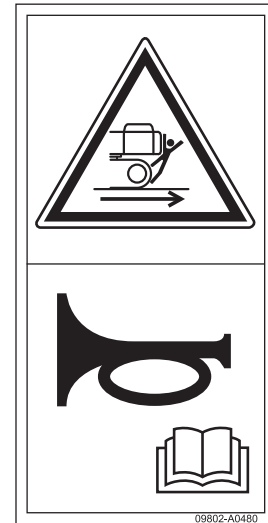

**(f) Control levers operational function diagram**

(09822-A0751)

In order to prevent an accident resulting in injury or death caused by error-operation, confirm the machine motion and indicated operating pattern, when operating machines. Pay attention to the circumference and operate slowly when confirming the machine motion.

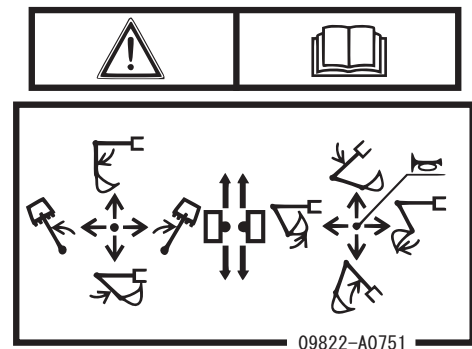



**(2) Caution for control pattern**

(09822-03010)

 <b>WARNING</b>
<p>This machine is equipped with a control pattern selector valve. To prevent personal injury caused by mistaken operation, always check that the movement of the machine matches the pattern shown on the control pattern card before starting operations.</p> <ul style="list-style-type: none"> <li>• When checking the movement of the machine, check that the surrounding area is safe and operate the machine slowly.</li> <li>• If the movement does not match the control pattern card, replace the card with the card showing the correct control pattern.</li> </ul> <p>Always do as follows when changing the control pattern.</p> <ul style="list-style-type: none"> <li>• Lower the work equipment to the ground, stop the engine, and set the lock lever to the LOCK position. Then change the control pattern.</li> </ul>
09822-03010

**(3) Caution when changing control pattern**

(22M-98-11181)

 <b>WARNING</b>
<ul style="list-style-type: none"> <li>• When changing the control pattern, set the machine in the parking condition, stop the engine, and set the lock lever to the LOCK position.</li> <li>• Align the control pattern selector lever to the specified position. (Check the detent.)</li> <li>• After changing the control pattern, do not forget to exchange the control pattern card and display the new control pattern card inside the operator's cab.</li> </ul>
22M-98-11181

**(4) Warning when swinging or travelling in reverse**

(09833-A0881)

 <b>WARNING</b>
<ul style="list-style-type: none"> <li>• When swinging or backing up excavator, press button to change display mode on monitor so you can see rear and side of the machine. Before moving, look around and at mirror and monitor to confirm that no one is around the machine. Failure to do so can result in serious injury or death.</li> </ul>



**(5) Warning for quick coupler system**

(20J-00-11271)

- There is a danger of an exposed person being killed by falling attachment.
- Read the manual for safe operation.

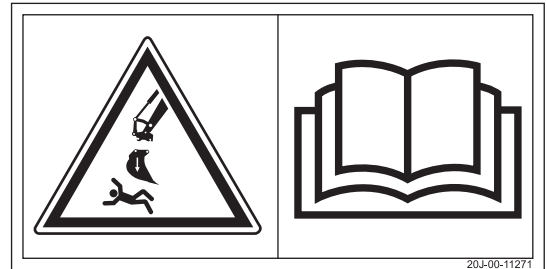
**(6) Warning for handling ROPS**

(09620-T2001, 09620-A3001)

- If any modification is applied to the ROPS, it may affect the strength and may not comply with the standard.
- ROPS may provide less protection if it has been structurally damaged or involved in roll-over.
- Always wear seat belt when moving.

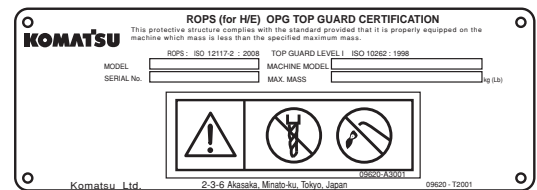
**(7) Caution for handling accumulator and gas spring**

(09659-A057B)

- There is a hazard of explosion causing injury.
- Do not disassemble the accumulator, make holes in it, weld it, cut it, roll it or bring it near a flame.

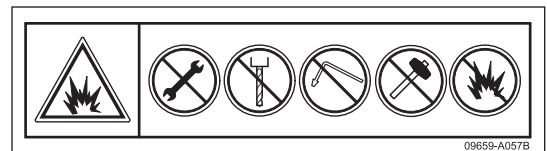
**(8) Caution for handling cable**

(09808-A0881)

- Sign indicates an electric hazard from handling the cable.
- Read manual for safe and proper handling.

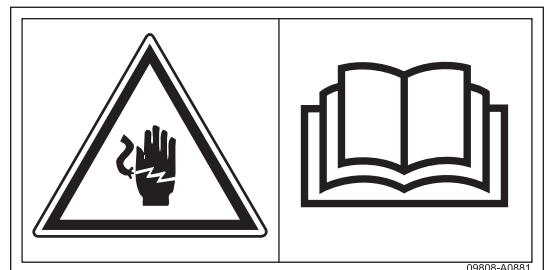
**(9) Caution for adjusting track tension**

(09657-A0881)

- Sign indicates a hazard of flying plug from track adjuster that could cause injury.
- Read manual regarding adjusting track for safe and proper handling.

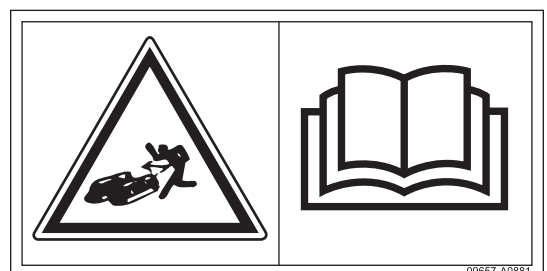

**(10) Caution for high temperature coolant and hydraulic oil**

(09653-A0481)

- Never remove the cap when the engine is at operating (high) temperature. Steam or high temperature oil blowing up from the radiator or hydraulic tank will cause personal injury and/or burns.
- Never remove the radiator cap or hydraulic tank oil filler cap when cooling water or hydraulic oil is at high temperature.



**(11) Emergency escape**

(09844-00050)

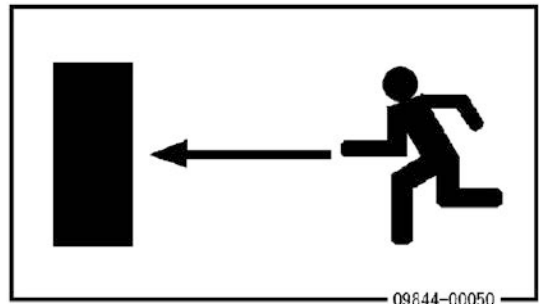

**(12) Caution stop rotation during inspection and maintenance**

(09667-A088B)

- Sign indicates a hazard of rotating parts such as belt, fan etc.
- Turn off before inspection and maintenance.

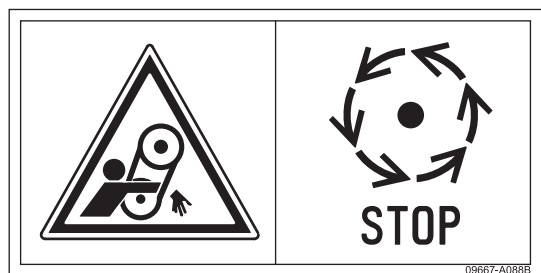

**(13) Danger do not enter within swing range**

(09133-A1681)

- There is a danger of getting caught when upper structure swings.
- Do not enter range of swing.

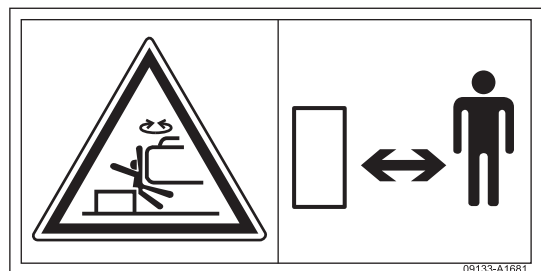

**(14) Caution for high-temperature**

(09817-A0753)

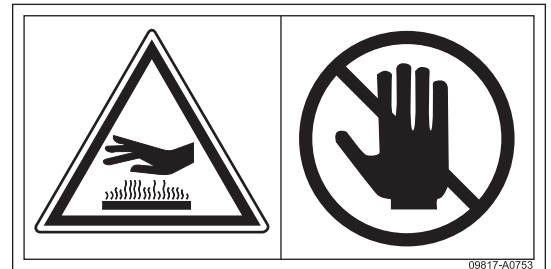
**(15) Caution do not start by short-circuiting**

(09842-A0481)

Prohibition of short-circuit start

**(16) Caution against falling**

(09805-C0641)

- Sign indicates a hazard of falling.
- Do not stand on the place here.

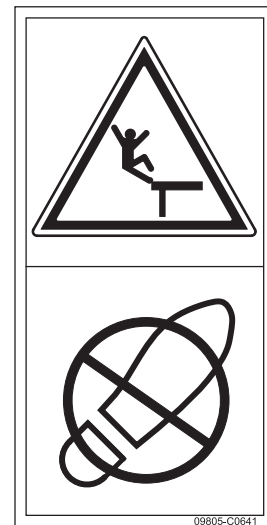
**(17) Caution when stowing front window**

(22P-00-11170)

- Sign indicates a hazard from falling window.
- After raising window, be sure to lock it in place with lock pins.

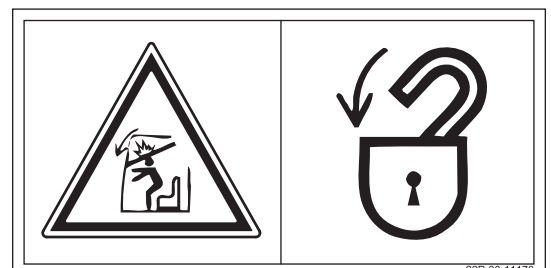

**(18) Caution for work equipment**

(09134-A0881)

Keeping out of working range area

- Sign indicates a hazard of being hit by the working device of the machine.
- Keep away from the machine during operation.

**(19) Caution for handling battery**

(09664-70001)



(a) Never smoke or use any naked flame near the batteries, no sparks.



(b) Always wear safety glasses when working with batteries.



(c) Keep children away from batteries.



(d) Caution battery acid.



(e) Read the operator's manual before working with batteries.



(f) Caution - explosive gases.



## (20) Caution for blast jobsite

(09845-00480)

Caution of an explosive hazard caused by active radio transmitter at a blast zone.

- Keep machine at a safe distance from blast zone and a detonator.

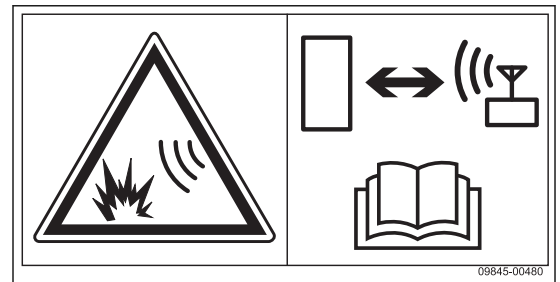

## GENERAL PRECAUTIONS COMMON TO OPERATION AND MAINTENANCE

Mistakes in operation, inspection, or maintenance may result in serious personal injury or death. Before performing operation, inspection, or maintenance, always read this manual and the safety labels on the machine carefully and obey the warnings.

### PRECAUTIONS BEFORE STARTING OPERATION

#### ENSURE SAFE OPERATION

- Only trained and authorized personnel can operate and maintain the machine.
- Follow all safety, precautions, and instructions in this manual when operating or performing inspection or maintenance on the machine.
- If you are not feeling well, or if you are under the influence of alcohol or medication, your ability to safely operate or repair your machine may be severely impaired, putting yourself and everyone else on your job site in danger.
- When working with another operator or with the person on the worksite traffic duty, discuss the content of the operation beforehand and use the determined signals when performing the operation.

#### UNDERSTAND THE MACHINE

Before operating the machine, read this manual thoroughly. If there is any place in this manual that you do not understand, ask the person in charge of safety for explanation.

### PREPARATIONS FOR SAFE OPERATION

#### PRECAUTIONS FOR SAFETY-RELATED EQUIPMENT

- Be sure that all guards, covers, cameras, and mirrors are in their proper position. Repair them immediately if they are damaged.
- Understand the using method of the safety related devices and use them properly.
- Never remove any safety related devices. Always keep them in good operating condition.

#### INSPECT MACHINE

Check the machine before starting operations. If any abnormality is found, do not operate the machine until repairs of the problem location have been completed.

### WEAR WELL-FITTING CLOTHES AND PROTECTIVE EQUIPMENT

- Do not wear loose clothes or any accessories. If any of these catch the control levers or protruding parts, it may cause the machine to move unexpectedly, it is extremely dangerous.
- Always wear a hard hat and safety shoes. Wear protective eyeglasses, mask, gloves, ear plugs, and safety belt as appropriate for the work function.
- Long hair hanging out from the hard hat is dangerous that it may get caught up in the machine. Tie the hair up and be careful not to be caught.
- Check that all personal protective items function properly before using them.

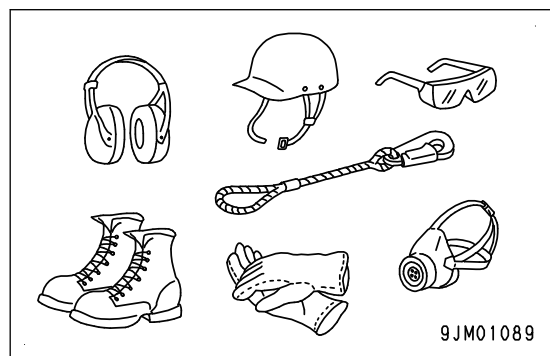

## KEEP MACHINE CLEAN

- If you get on or off the machine or perform inspection and maintenance on the machine with mud or oil, you may slip and fall, and it is dangerous. Wipe off any mud or oil from the machine. Always keep the machine clean.
- If water gets into the electrical system, electric devices will cause malfunctions, and the machine will cause error. If the machine cause error, it may move unexpectedly and cause serious personal injury or death. When washing the machine with water or steam, do not allow the water or steam to come into direct contact with electrical components.
- If high-pressure water is sprayed directly onto camera, it may cause failure. Do not allow the high-pressure water to get into camera directly. When cleaning the camera, wipe off any dirt with soft cloth.
- When cleaning camera, if you stand on an unstable place, or take an unstable posture, you may fall and be injured. Put proper stepladder or step on the level and firm ground, and clean the camera in secure posture.

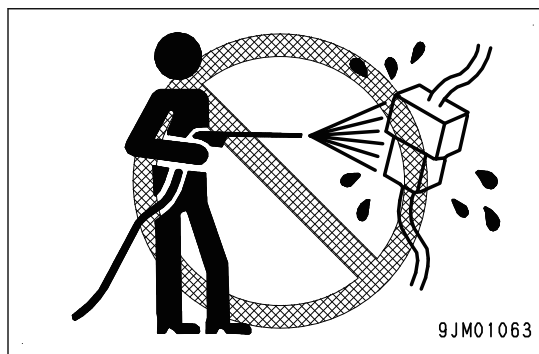

## PRECAUTIONS FOR INSIDE OPERATOR'S COMPARTMENT

- When entering the operator's compartment, always remove all mud and oil from the soles of your shoes. If you operate the pedal with mud or oil affixed to your shoes, your foot may slip and this may cause a serious accident.
- Do not leave tools or machine parts lying around inside the operator's compartment. If tools or parts get into the control devices, it may obstruct operation and cause the machine to move unexpectedly, resulting in serious personal injury or death.
- Do not stick suction pads to the window glass. Suction pads act as a lens and may cause fire.
- Do not use a cellular phone when driving or operating the machine. This may lead to mistakes in operation, and may cause serious personal injury or death.
- Never bring any dangerous objects such as flammable or explosive items into the operator's compartment.

## PROVIDE FIRE EXTINGUISHER AND FIRST AID KIT

Observe the following precautions to prepare for action if any serious personal injury or death or fire should occur.

- Be sure that fire extinguishers have been provided and read the labels to ensure that you know how to use them for the possibility of fires.
- Perform periodic inspection and maintenance to ensure that the fire extinguisher can always be used.
- Provide a first aid kit in the storage point. Perform periodic checks and add to the contents if necessary.

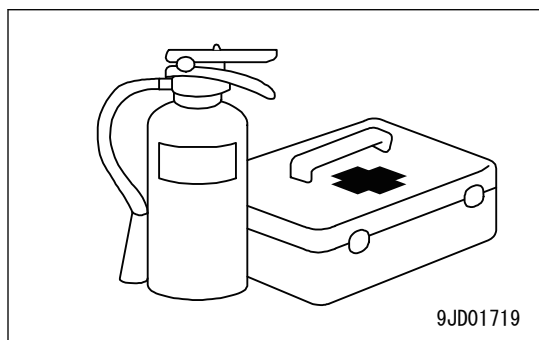

## IF ANY PROBLEM IS FOUND

If you find any problem in the machine during operation or maintenance (noise, vibration, smell, incorrect gauges, smoke, oil leakage, etc., or any abnormal display on the warning devices or monitor), report to the person in charge and take the necessary action. Do not operate the machine until the problem has been corrected.



## PRECAUTIONS TO PREVENT FIRE

### ACTIONS IF FIRE OCCURS

- Turn the starting switch to OFF position, and stop the engine.
- Use the handrails and steps to escape from the machine.
- Do not jump off the machine. There is the danger of falling and it may cause personal injury.
- The fume generated by a fire contains harmful materials which have a bad influence on your body when they are inhaled.  
Do not breathe the fumes.
- After a fire, harmful compounds may be left. If it touches your skin, it may have a bad influence on your body.  
Be sure to wear rubber gloves when handle the materials left after the fire.  
The material of the gloves, which is recommended is polychloroprene (Neoprene) or polyvinyl chloride (in the lower temperature environment).  
When wearing cotton work gloves, wear rubber gloves under them.

### PREVENT FIRE

#### Fire caused by fuel, oil, coolant, or window washer fluid

Do not bring any open flame close to flammable substances such as fuel, oil, coolant, or window washer fluid. There is a danger that they may catch fire. Always observe the following.

- Do not smoke or use any open flame near fuel or other flammable substances.
- Shut down the engine before adding fuel.
- Do not leave the machine when adding fuel or oil.
- Tighten all the fuel and oil caps securely.
- Be careful not to spill fuel on overheated surfaces or on parts of the electrical system.
- After adding fuel or oil, wipe up any spilled fuel or oil.
- Put greasy rags and other combustible materials into a safe container to maintain safety at the workplace.
- When washing parts with oil, use a non-flammable oil. Do not use diesel fuel or gasoline. There is danger that they may catch fire.
- Do not weld or use a cutting torch to cut any pipes or tubes that contain flammable liquids.
- Determine well-ventilated areas for storing oil and fuel. Keep the oil and fuel in the specified place and do not allow unauthorized persons to enter.
- When performing grinding or welding work on the machine, move any flammable materials to a safe place before starting.

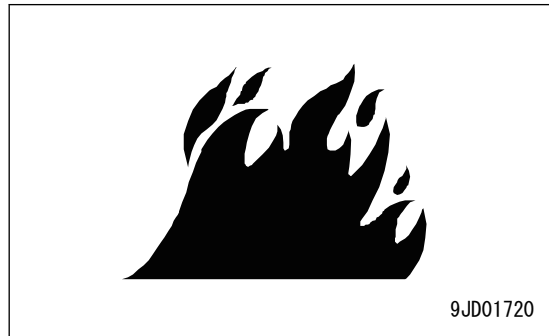

#### Fire caused by accumulation of flammable material

- Remove any dry leaves, chips, pieces of paper, coal dust, or any other combustible materials accumulated or affixed around the engine exhaust manifold, muffler, or battery, or inside the undercovers.
- To prevent fires from spreading sparks or burning particles from other fires, remove any combustible materials such as dry leaves, chips, pieces of paper, coal dust, or any other combustible materials accumulated around the cooling system (radiator, oil cooler) or inside the undercover.

#### Fire coming from electric wiring

Short circuits in the electrical system can cause fire. Always observe the following.

- Keep all the electric wiring connections clean and securely tightened.

- Check the wiring every day for looseness or damage. Reconnect any loose connectors or refasten wiring clamps. Repair or replace any damaged wiring.

### **Fire caused from piping**

Check that all the hose and tube clamps, guards, and cushions are securely fixed in position.

If they are loose, they may vibrate during operation and rub against other parts. There is danger that this may lead to damage to the hoses and cause high-pressure oil to spurt out, leading to fire and serious personal injury.

### **Explosion caused by lighting equipment**

When checking fuel, oil, battery electrolyte, or coolant, always use lighting with anti-explosion specifications.

## PRECAUTIONS WHEN GETTING ON OR OFF MACHINE

### USE HANDRAILS AND STEPS WHEN GETTING ON OR OFF MACHINE

To prevent personal injury caused by slipping or falling off the machine, always observe the following.

- Use the handrails and steps marked by arrows in the figure on the right when getting on and off the machine.

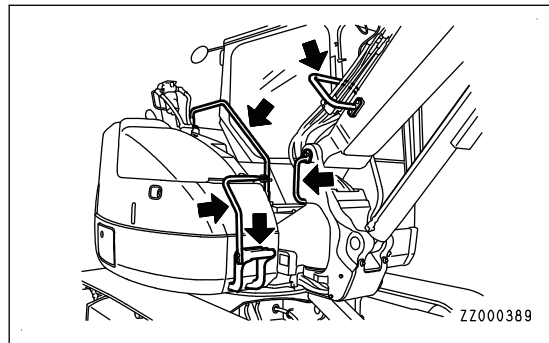
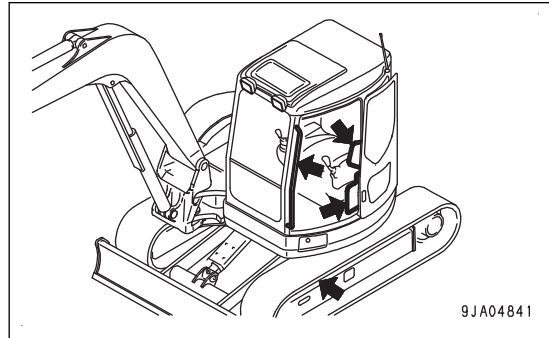

- Always face the machine and maintain at least three-point contact (both feet and one hand, or both hands and one foot) with the handrails and steps to ensure that you support yourself.
- Before getting on and off the machine, check the handrails and steps if there is any oil, grease, or mud on them. Wipe it off immediately not to slip if any. In addition, tighten any loose bolt of the handrails and steps. If the handrails and steps are damaged or deformed, they need to be repaired immediately. Ask your Komatsu distributor to perform this work.

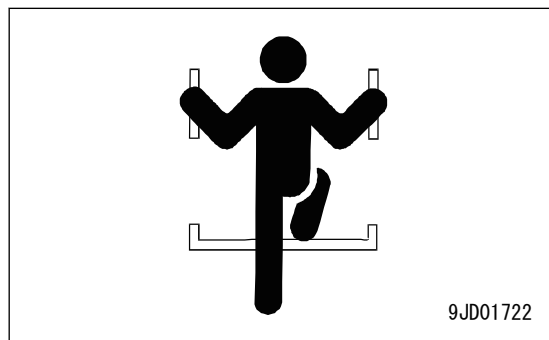

- Do not grip the control levers or lock lever when getting on or off the machine.
- Never climb on the engine hood or covers where there are no non-slip pads.
- Do not get on or off the machine with tools in your hand.

### NO JUMPING ON OR OFF MACHINE

Getting on or off the moving machine can cause serious personal injury or death. Always observe the following.

- Never jump on or off the machine. Never get on or off a moving machine.
- If the machine starts to move when there is no operator on the machine, do not jump on to the machine and try to stop it.

### NO PEOPLE ON ATTACHMENTS

Never let anyone ride on the work equipment or other attachments. There is a hazard of falling and suffering serious personal injury or death.

## PRECAUTIONS WHEN STANDING UP FROM OPERATOR'S SEAT

Before standing up from the operator's seat, such as when opening or closing the front window or ceiling window, when removing or installing the bottom window, or adjusting the position of the seat, always lower the work equipment completely to the ground, set lock lever (1) to lock position (L), and stop the engine.

If the control levers are touched by mistake, there is danger that the machine may suddenly move and cause serious personal injury or death.

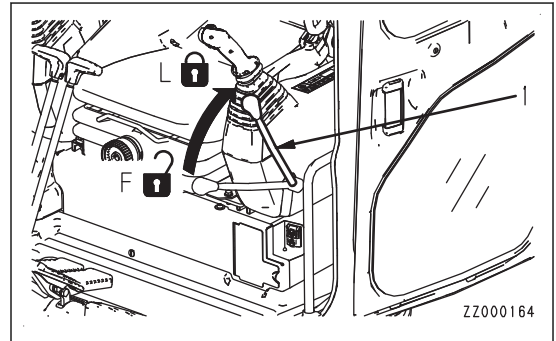

## PRECAUTIONS WHEN LEAVING MACHINE

If the proper procedures are not taken when parking the machine, the machine may suddenly move off by itself, and this may lead to serious personal injury or death. Always observe the following.

When leaving the machine, always lower the work equipment completely to the ground, set lock lever (1) to lock position (L), and stop the engine. In addition, lock all places and always take the key with you and keep it in the specified location.

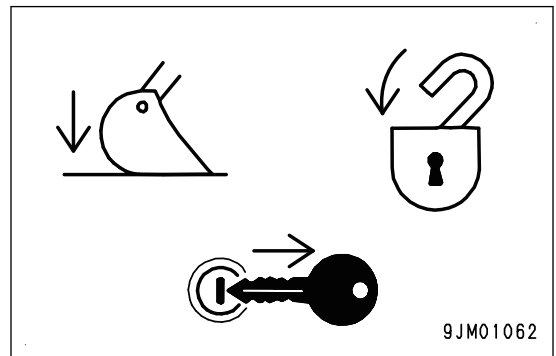
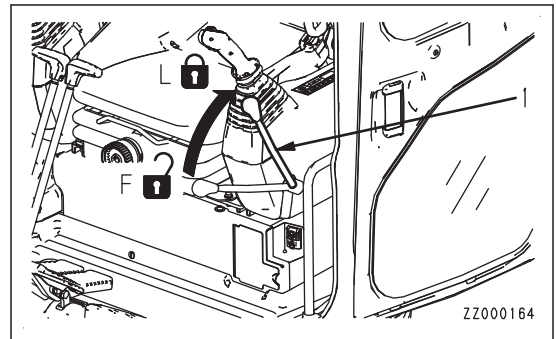

## EMERGENCY EXIT FROM OPERATOR'S CAB

- If it should be impossible to open the door of the cab, break the window glass with the hammer supplied and use the window as an emergency escape.
- When escaping, remove all the pieces of glass from the window frame first and be careful not to cut yourself on the glass. Be careful also not to slip on the broken pieces of glass on the ground.

## DO NOT GET CAUGHT IN WORK EQUIPMENT

The clearance in the area around the work equipment changes according to the movement of the link. If you are caught, this may lead to serious personal injury or death. Do not allow anyone near any of the rotating or telescopic parts.

## PRECAUTIONS RELATED TO PROTECTIVE STRUCTURES

The operator's compartment is equipped with a structure (such as ROPS, OPG) to protect the operator by absorbing the impact energy.

As for the machine equipped with ROPS, if the machine weight (mass) exceeds the certified value (shown on ROLL-OVER PROTECTIVE STRUCTURE (ROPS) CERTIFICATION plate), ROPS will not be able to fulfill its function. Do not increase machine weight beyond the certified value by modifying the machine or by installing attachments to the machine.

Also, if the function of the protective equipment is impeded, the protective equipment will not be able to protect the operator, and the operator may suffer injury. Always observe the following.

- If the machine is equipped with a protective structure, do not remove the protective structure and perform operations without it.
- If the protective structure is welded, or holes are drilled in it, or it is modified in any other way, its strength may drop. Any modification is prohibited.
- If the protective structure is damaged or deformed by falling objects or by rolling over, its strength will be reduced and it will not be able to fulfill its function properly. In such cases, always consult your Komatsu distributor.
- Even if the protective structure is installed, always fasten your seat belt properly when operating the machine. If you do not fasten your seatbelt properly, it cannot display its effect. Always fasten your seat belt while operating the machine.



## PROTECTION AGAINST FALLING, FLYING OR INTRUDING OBJECTS

On jobsite where there is a danger of falling objects, scattering fragments, and things which may intrude into operator's cab, install the necessary equipment to protect the operator depending on the working conditions.

- When operating on jobsite, such as mines or quarries where there is a hazard of falling rocks, install falling object protective structure (FOPS) and a front guard, and always keep all the windows and doors closed when operating. In addition, always check that there is no one except the operator in the surrounding area where there is a danger of falling objects, scattering fragments.
- When performing demolition or breaker operations, install a front guard and always keep all the windows closed during operation. In addition, always check that there is no one except the operator in the surrounding area where there is a danger of falling objects, scattering fragments.

Above precautions are developed for the standard jobsite. Depending on the conditions of the jobsite, installation of additional guards is necessary.

Do not operate the machine without the necessary guards. Be sure to consult with your Komatsu distributor about necessary guards.

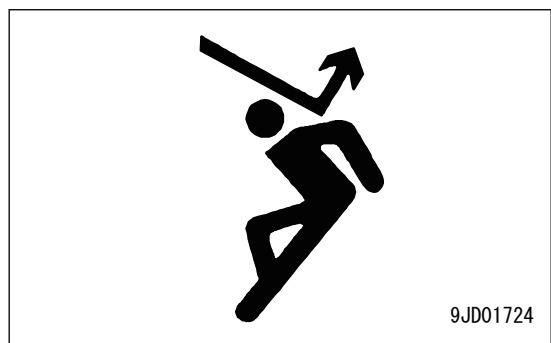
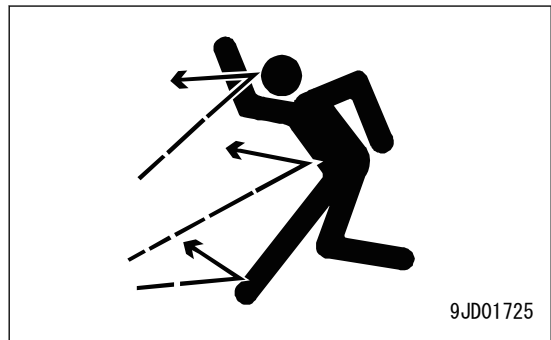

## UNAUTHORIZED MODIFICATION

- Komatsu will not be responsible for any personal injuries, product failures, physical loss or damage, or influence on the environment resulting from modifications made without authorization from Komatsu.
- Any modification made without authorization from Komatsu can create hazards. Before making a modification, consult your Komatsu distributor.

## PRECAUTIONS RELATED TO ATTACHMENTS AND OPTIONS

- Any serious personal injury, or product failures, or physical loss or damage resulting from the use of unauthorized attachments or parts will not be the responsibility of Komatsu.
- When installing optional parts or attachments, contact your Komatsu distributor for advice to any potential problems or safety and legal requirements.
- The machine weight will not exceed ROPS certified value as long as the optional attachments written in the attachment combination table of this manual are installed. When installing optional parts or attachments which are not written in this manual, the machine weight must not exceed ROPS certified value. Always contact your Komatsu distributor before installing.
- Installing some work equipment combinations may cause interference and damage with the cab or other parts of the machine during operation and could cause serious personal injury or death. Before using unfamiliar work equipment, always check for potential interference while operating the machine. Always ensure the operator's safety when working with unfamiliar work equipment.
- When installing and using optional attachments, always read the instruction manual for the attachment, and the general information related to attachments in this manual.

## PRECAUTIONS RELATED TO CAB GLASS

- If the cab glass is broken during operations, stop operations and repair the cab glass immediately.
- If the cab glass on the work equipment side is broken, there is a hazard that the operator may be directly hit or caught in the work equipment. If the glass is broken, stop operation immediately and replace the glass.
- The ceiling window is made of plastic, so if it is scratched, the visibility will become poor and there is danger that it may break. If the ceiling window is scratched, replace it with the new one as soon as possible. If the ceiling window is scratched and is not replaced, there is a danger that any rocks falling on it will cause it to break, leading to injury to the operator.

## PRECAUTIONS WHEN RUNNING ENGINE INSIDE BUILDING

The engine exhaust gas contains substances that may damage your health or even cause death. Start or operate the engine in a place where there is good ventilation. If the engine or machine must be operated inside a building or underground, where the ventilation is poor, take steps to ensure that the engine exhaust gas is removed and that ample fresh air is brought in.

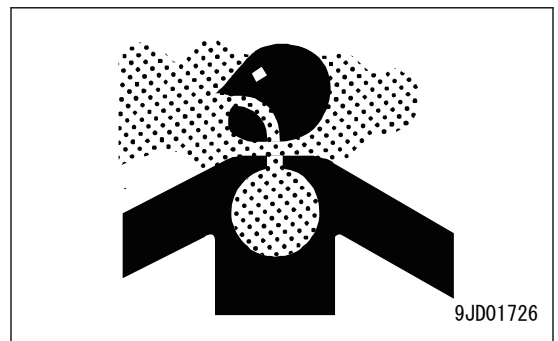

# PRECAUTIONS FOR OPERATION

## PRECAUTIONS FOR JOBSITE

### INVESTIGATE AND CONFIRM JOBSITE CONDITIONS

On the jobsite, there are various hidden dangers that may lead to serious personal injury or death. Before starting operations, always check the following to confirm that there is no danger on the jobsite.

- Always be careful when performing operations near materials such as thatched houses, dry leaves or dry grass, because they are easily combustible and may cause fire.
- Check the terrain and condition of the ground at the jobsite, and determine the safest method of operation. Do not operate in a dangerous area where landslides or rockfall may occur.
- If water lines, gas lines, or high-voltage electrical lines may be buried under the jobsite, contact the management company to identify their locations, and be careful not to damage any of these lines.
- Take necessary measures to prohibit other personnel from coming close to the machine during operation.
- In particular, if you need to operate on a road, protect pedestrian and cars by designating a person for jobsite traffic duty or by installing fences around the jobsite.
- When traveling or operating in shallow water or on soft ground, check the water depth, speed of the current, condition of bedrock, and shape of the ground beforehand. Always avoid any place that will obstruct travel.

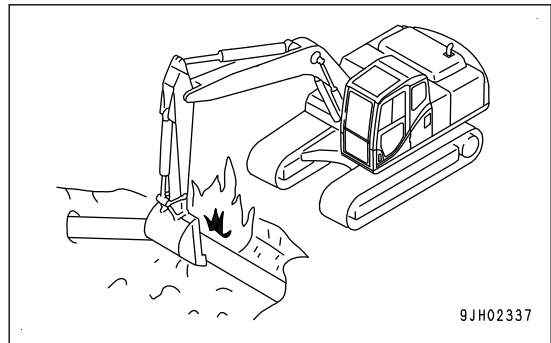

### PRECAUTIONS WHEN WORKING ON LOOSE GROUND

- Avoid driving or operating the machine near the edge of cliffs, road edges, and deep ditches. The ground may be weak in such areas. If the ground should collapse under the weight or vibration of the machine, there is a hazard that the machine may fall or tip over. Remember that the soil is weak in these areas, after heavy rain or blasting or after earthquakes.
- When working on embankments or near excavated ditches, there is a hazard that the weight and vibration of the machine will cause the soil to collapse. Before starting operations, take steps to ensure that the ground is safe and to prevent the machine from rolling over or falling.

## DO NOT GO CLOSE TO HIGH-VOLTAGE CABLES

Do not travel or operate the machine near electric cables. There is a hazard of electric shock, which may cause serious personal injury or death. On jobsites where the machine may go close to electric cables, always observe the following.

- Before starting work near electric cables, inform the local power company of the work to be performed, and ask them to take the necessary action.
- Even going close to high-voltage cables can cause electric shock. Always maintain a safe distance (see the table) between the machine and the electric cable. Check with the local power company about the voltage of cables and safe operating procedure before starting operations.

VOLTAGE	MIN. DISTANCE
50 kV or Less	3.1 m {10 ft}
50 kV to 200 kV	4.6 m {15 ft}
200 kV to 350 kV	6.1 m {20 ft}
350 kV to 500 kV	7.7 m {25 ft}
500 kV to 750 kV	10.7 m {35 ft}
750 kV to 1000 kV	13.8 m {45 ft}



- To prepare for any possible emergencies, wear rubber shoes and gloves. Lay a rubber sheet on the operator's seat, and be careful not to touch the chassis with any exposed part of your body.
- Use a signalman to give warning if the machine approaches too close to the electric cables.
- When performing operations near high voltage cables, prohibit anyone other than related persons to come close to the machine during operation.
- If the machine should come too close or touch the electric cable, to prevent electric shock, the operator should not leave the operator's compartment until it has been confirmed that the electricity has been shut off. Also, prohibit any other persons to come close to the machine.

## ENSURE GOOD VISIBILITY

Although this machine is equipped with mirrors and cameras (machines equipped with cameras) to ensure good visibility, there are places that cannot be seen from the operator's seat. Be careful when performing operation.

When driving the machine or performing operations in places with poor visibility, it is dangerous and may cause serious personal injury or death because it is difficult to check for obstacles and condition of the jobsite. When driving the machine or performing operations in places with poor visibility, always observe the following.

- Allocate a signalman for jobsite duty if there are areas where the visibility is poor.
- Only one signalman should give signals.
- When working in dark places, turn on the working lamp and head lamps installed to the machine, and set up additional lighting in the work area if necessary.
- Stop operations if the visibility is poor because of mist, snow, rain, or dust.
- When checking the mirrors installed to the machine, remove all dirt and adjust the angle of the mirror to ensure good visibility.
- When cleaning the camera, wipe off any dirt with soft cloth. Make sure that a clear view is displayed on the monitor. When cleaning the camera, if you stand on an unstable place, or take an unstable posture, you may fall and be injured. Put proper stepladder or step on the level and firm ground, and clean the camera in secure posture.



### CHECK SIGNS AND SIGNALMAN'S SIGNALS

If signals and labels are not clear, serious personal injury can result from downward slip, overturn or accidental contact with nearby people or obstacles. Always observe the following.

- Set up labels to inform of road edges and soft ground. If the visibility is not good, position a conductor if necessary. Operator should pay careful attention to the labels and follow the instructions from the conductor.
- Only one signalman should give signals.
- Make sure that all workers understand the meaning of all signals, signs, and labels before starting work.

### BEWARE OF ASBESTOS DUST

Asbestos dust in the air can cause lung cancer if it is inhaled. There is danger of inhaling asbestos when working on jobsite where demolition work is performed or industrial waste is handled. Always observe the following.

- Spray water to keep down the dust.
- Do not use compressed air.
- If there is danger that there may be asbestos dust in the air, always operate the machine from an upwind position, and make sure that all workers operate on the upwind side.
- All workers should use anti-dust masks.
- Prohibit other personnel from coming close to the machine during operation.
- Always observe the regulations for jobsite and environmental standards.



This machine does not contain asbestos, but any part which is not the genuine part, it has risk of containing asbestos. Always use Komatsu genuine parts.

### START ENGINE

#### USE WARNING TAGS

If there is a "DANGER! Do NOT operate!" warning tag displayed, it means that someone is performing inspection and maintenance of the machine. If the warning tag is ignored and the machine is operated, the person performing inspection or maintenance may be caught in the rotating parts or moving parts. It is dangerous and may cause serious personal injury or death. Do not start the engine or touch the levers.

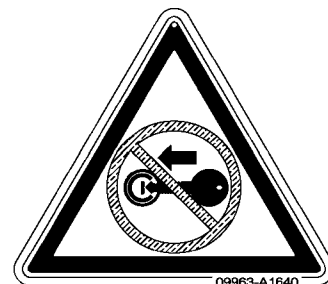
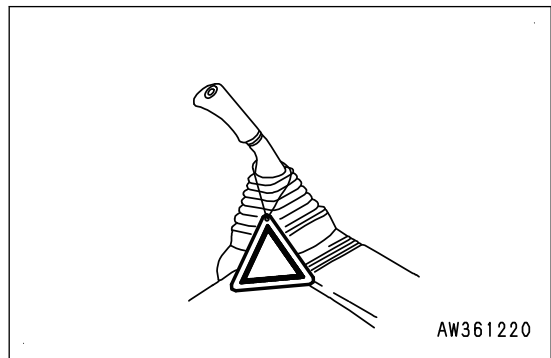

## CHECKS AND ADJUSTMENT BEFORE STARTING ENGINE

Perform the following checks before starting the engine at the beginning of the day's work to ensure that there is no problem with the operation of the machine. If these checks are not performed properly, problems may occur with the operation of the machine, and there is a danger which may lead to serious personal injury or death.

- Remove all dirt from the surface of the window glass to ensure a good view.
- Perform the walk-around check.
- Remove all dirt from the surface of the lens of the headlamps and working lamps, and check that they light up correctly.
- Check the coolant level, fuel level, and oil level in engine oil pan, check for clogging of the air cleaner, and check for damage to the electric wiring.
- Check that there is no mud or dust accumulated around the movable parts of any pedals, and check that the pedals work properly.
- Adjust the operator's seat to a position where it is easy to perform operations, and check that there is no damage or wear to the seat belt or mounting clamps.
- Check that the gauges work properly, check the angle of the mirror, and check that the control levers are all at NEUTRAL position.
- Before starting the engine, check that lock lever (1) is in LOCK position (L).
- Adjust the mirrors so that the rear of the machine can be seen easily from the operator's seat.
- Adjust the angle of camera so that the surrounding area can be seen clearly from the operator's seat.
- Adjust the armrest to a position for easier operation, and then fix it securely. Operation in an improper position can cause a serious personal injury or death.
- Check that there are no people or obstacles above, below, or in the area around the machine.

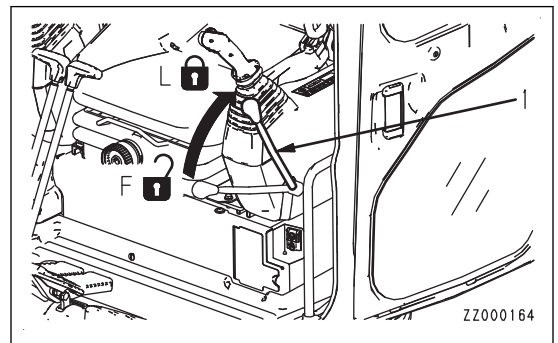

## PRECAUTIONS WHEN STARTING ENGINE

The machine may suddenly move off and this may lead to serious personal injury or death. Always observe the following.

- Start the engine only while sitting down in the operator's seat.
- When starting the engine, sound the horn as a warning.
- Prohibit other personnel to get on the machine.
- Do not attempt to start the engine by short-circuiting the engine starting circuit. This may cause fire, serious personal injury or death.

## IN COLD WEATHER

- If the warm-up operation is not performed thoroughly, and the work equipment is operated, the reaction of the work equipment to the operation of the control levers and pedals will be slow and the movement of it may not be what the operator intended. Be sure to perform the warm-up operation. Particularly in a cold weather, be sure the warming-up operation is completed.
- If the battery electrolyte is frozen, do not charge the battery or start the engine with a different power source. There is a hazard that this will ignite the battery and cause the battery to explode. Before charging or starting the engine with a different power source, melt the battery electrolyte and check that there is no leakage of electrolyte before starting.

### START ENGINE WITH JUMPER CABLES

If any mistake is made in the method of connecting the jumper cables, it may cause the battery to explode, so always observe the following.

- Always wear protective eyeglasses and rubber gloves when starting the engine by using the jumper cables.
- When connecting a normal machine to a failed machine with the jumper cables, always use the normal machine with the same battery voltage as the failed machine.
- When starting the engine with the jumper cables, perform the starting operation with 2 workers (one worker sitting in the operator's seat and the other working with the battery).
- When starting from another machine, be careful that the normal machine does not contact with the failed machine.
- When connecting the jumper cables, turn the starting switch to OFF position for both the failed machine and the normal machine. If the failed machine has a battery disconnect switch, turn it to OFF position, and turn it ON again after connecting the cables. It is dangerous that the machine may move when the power is connected.
- Be sure to connect the positive (+) cable first when installing the jumper cables. Disconnect the negative (-) cable (ground side) first when removing them.
- When disconnecting the jumper cables, take care not to bring the clips in contact with each other or with the machine.

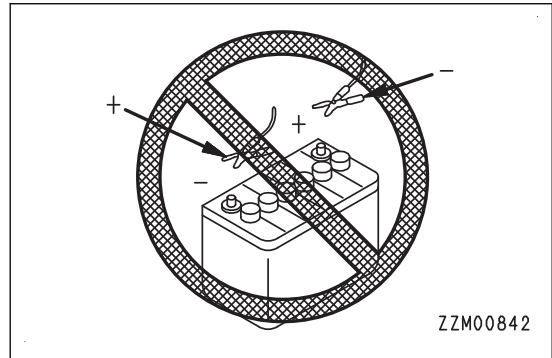

### PRECAUTIONS FOR OPERATION

#### CHECKS BEFORE OPERATION

If the checks before starting are not performed properly, the machine will be unable to display its full performance. It is dangerous and may cause serious personal injury or death.

When performing the checks, move the machine to a wide area with no obstructions, and pay careful attention to the surroundings. Prohibit other personnel from coming close to the machine during checks.

- Fasten the seatbelt. When the brakes are applied suddenly, the operator may be thrown out of the operator's seat. It is dangerous and may cause personal injury.
- Check that the movement of the machine matches the display on the control pattern card. If it does not match, replace it immediately with the correct control pattern card.
- Check the operating condition of the machine, work equipment, and travel and swing systems.
- Check for any problem in the sound, vibration, heat and smell of the machine, or abnormalities of instruments. Also check that there is no leakage of oil or fuel.
- If any problem is found, repair it immediately.

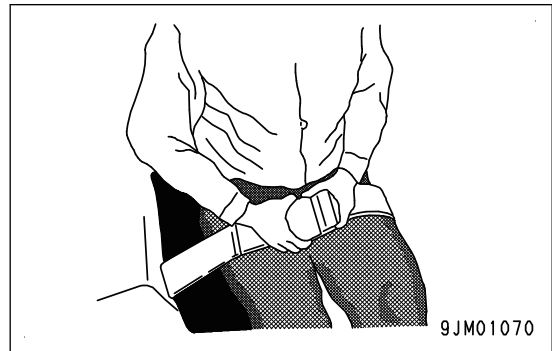

## PRECAUTIONS WHEN TRAVELING IN FORWARD OR REVERSE AND SWINGING

- When driving the machine, drive with sprocket (1) at the rear of the machine. If sprocket (1) is at the front, the operation of the travel levers will be the opposite of the actual direction of travel, so there is a hazard that the machine may travel in an unexpected direction, leading to serious injury or death.

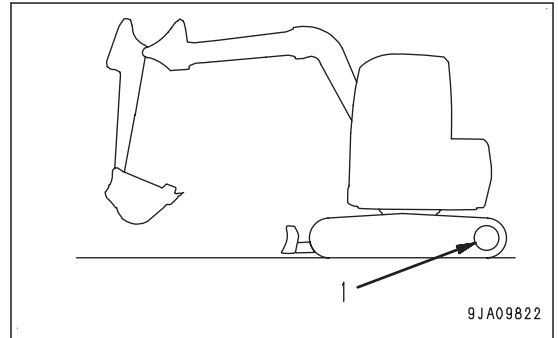

- Always lock all the doors and windows of the operator's compartment in position regardless of whether it is open or closed.

Always close all the windows and doors on jobsites where there is danger of scattering fragments, and things which may intrude into operator's cab.

- Prohibit anyone other than the operator to get on the machine.
- If there are any people in the area around the machine, there is danger that they may be hit or caught by the machine, and this may lead to serious personal injury or death. Before starting travel or swing, be sure to observe the following.

- Always operate the machine only when seated on the operator's seat.
- Before starting to move, check again that there is no people or obstacle in the surrounding area.
- Before moving, sound the horn to warn people in the surrounding area.
- Check that the travel alarm and other alarms work properly.
- If there is an area in the rear of the machine which cannot be seen, position a signalman. Be extremely careful not to hit any people or object, and drive or swing slowly.

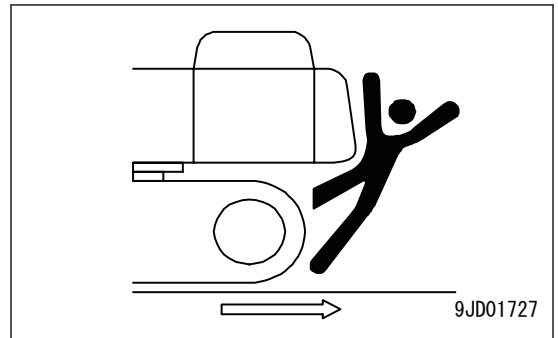

Always be sure to perform the above precautions even when the machine is equipped with mirrors and cameras.

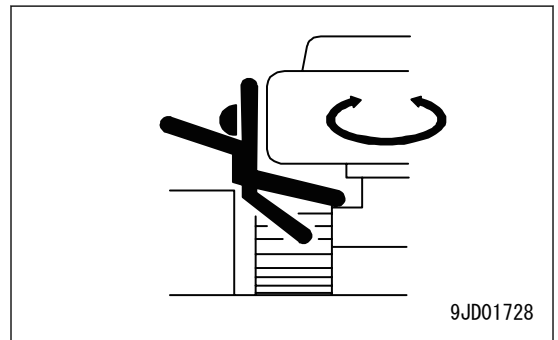

## PRECAUTIONS WHEN TRAVELING

Serious personal injury or death can result from tipping over of the traveling machine or its accidental contact. Always observe the following.

- When driving the machine or performing operations, always keep a safe distance from people, structures, or other machines to avoid coming into contact with them.
- When driving the machine on a level ground, keep the work equipment 40 to 50 cm {16 to 20 in} above the ground. If that height is not maintained between the work equipment and the ground, the work equipment may get stuck in the ground and the machine may tip over.
- If the view to the right side is poor, raise the boom to ensure better visibility.
- Always turn the auto-deceleration switch OFF (cancel) when driving the machine on rough ground or steep slopes. If the machine is operated with the auto-deceleration system ON, the engine speed will rise and the machine travel speed may suddenly become faster.
- Try to avoid traveling over obstacles. If the machine has to travel over an obstacle, keep the work equipment close to the ground and travel at low speed. The machine tips over easily to the right or left. Do not drive it over obstacles which make the machine tilt largely to the right or left.
- When driving the machine on the rough ground, drive it at low speed and do not operate the steering suddenly. There is a danger that the machine may tip over. The work equipment may hit the ground, and the machine may lose its balance, or it may damage the machine or structures in the area.
- When using the machine, to prevent serious personal injury or death caused by the work equipment or by the machine tipping over due to overloading, do not use the machine beyond the permitted performance of the machine such as the maximum permitted load for the structure of the machine.
- When passing over bridges or structures, check first that the structure is strong enough to support the weight of the machine.
- When operating in tunnels, under bridges, under electric wires, or other places where the height is limited, operate slowly and be extremely careful not to let the machine body or work equipment hit anything.

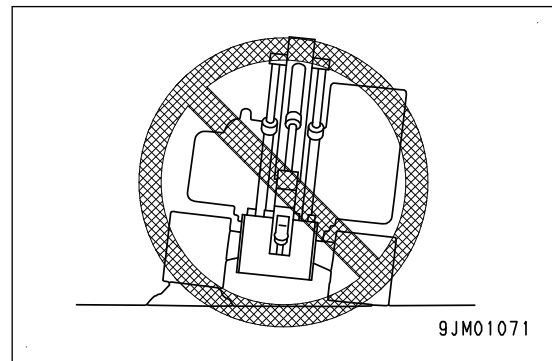
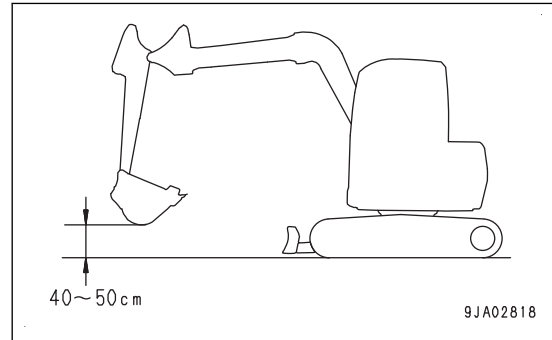

## PRECAUTIONS WHEN TRAVELING ON SLOPES

To prevent the machine from tipping over or slipping to the side, always observe the following.

- Keep the work equipment at height (a) of approximately 20 to 30 cm {8 to 12 in} above the ground. In case of emergency, lower the work equipment to the ground immediately to help stopping the machine.
- When driving the machine up slopes, set the operator's cab facing uphill, when driving downhill, set the operator's cab facing downhill. Always be sure of the safety of the ground under the front of the machine when driving.

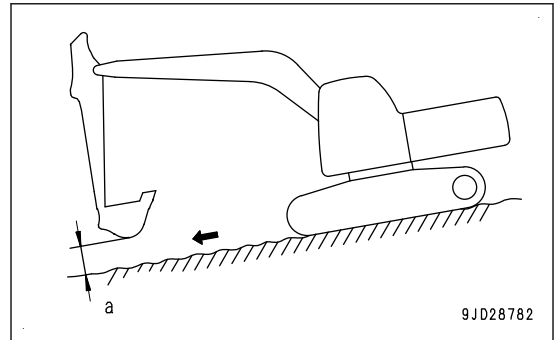
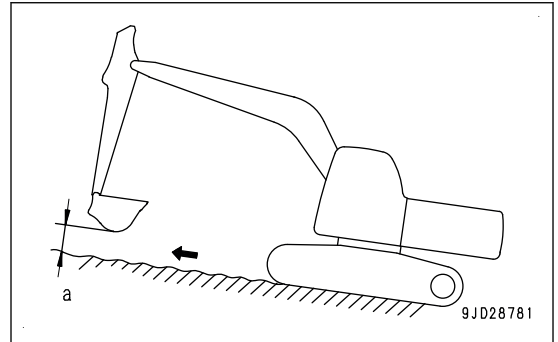

- When driving the machine up a steep slope, extend the work equipment to the front to improve the balance, keep the work equipment at height (a) of approximately 20 to 30 cm {8 to 12 in} above the ground, and drive it at low speed.

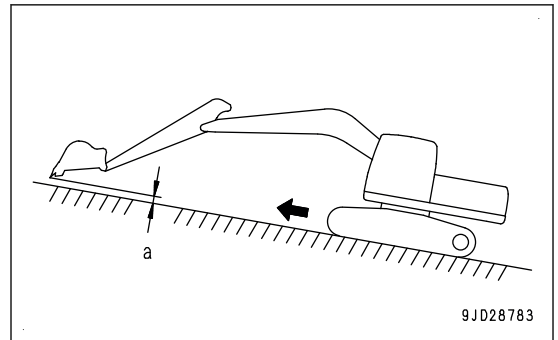

- When driving the machine downhill, lower the engine speed, keep the travel lever close to NEUTRAL position, and drive it at low speed.
- Always drive the machine straight up or down a slope. Driving the machine at an angle or across the slope is extremely dangerous.
- Do not turn on slopes or drive across slopes. Always go down to a flat place to change the position of the machine, then drive it on to the slope again.

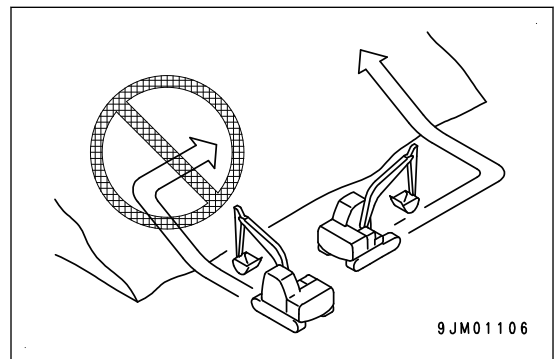

- Do not drive the machine on a slope covered with the steel plates. Even with slight slopes there is a hazard that the machine may slip.
- Drive the machine at low speed on the grass or fallen leaves. Even with slight slopes, there is a hazard that the machine may slip.

- If the engine stops, move the control levers immediately to NEUTRAL position, set the lock lever to LOCK position, and then start the engine.

**PRECAUTIONS WHEN OPERATING ON SLOPES**

- When working on slopes, there is a hazard that the machine may lose its balance and turn over when performing swing or work equipment operations. This may lead to serious personal injury or death. Always provide a stable place when performing these operations, and operate carefully.
- Do not swing the work equipment from the uphill side to the downhill side when the bucket is loaded. This operation is dangerous, and may cause the machine to turn over.
- If the machine has to be used on a slope, pile the soil to make a platform (A) that will keep the machine as horizontal as possible.
- Do not work on a slope covered with the steel plates. Even with slight slopes there is a hazard that the machine may slip.

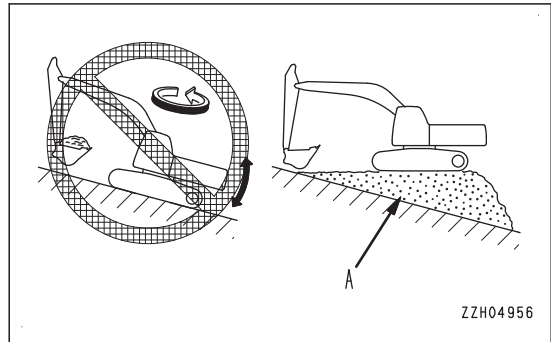

**PROHIBITED OPERATIONS**

If the machine turns over or falls, or the ground at the working point collapses, or a structure being demolished collapses, it may lead to serious personal injury or death. Always observe the following.

- It is dangerous to work under an overhang. Mudslide or rockfall may occur, or the overhang may collapse. Never perform digging under an overhang.

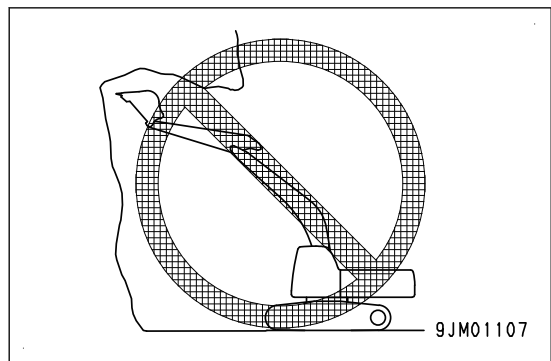

- Do not excavate too deeply under the front of the machine. The ground under the machine may collapse and cause the machine to fall.

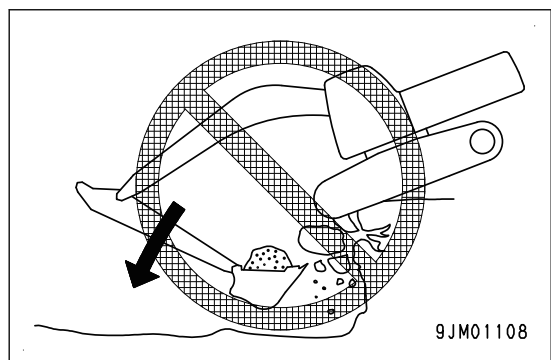

- For a quick escape in an emergency, set the tracks at right angles to the road shoulder or cliff with the sprocket at the rear when performing operations.

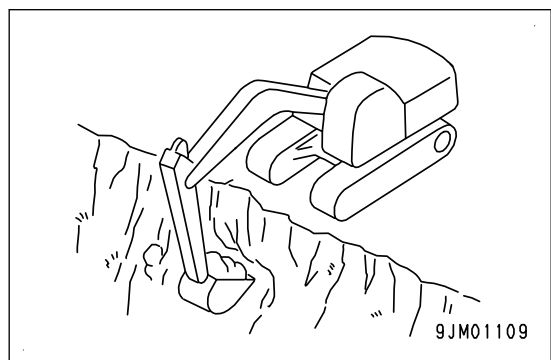

- Do not demolish the structure where the machine is placed on. It is dangerous that the structure may collapse and the machine may fall.

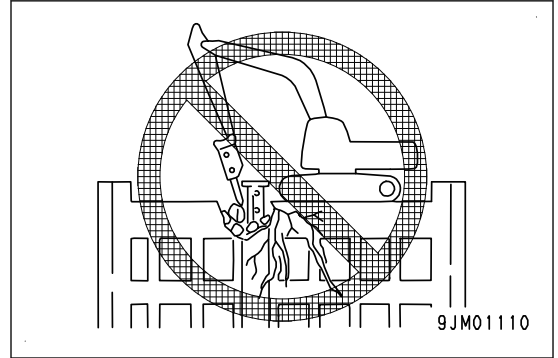

- Do not demolish the structure above the machine. It is dangerous that broken parts may fall or the structure may collapse, and it may cause serious injury or death.

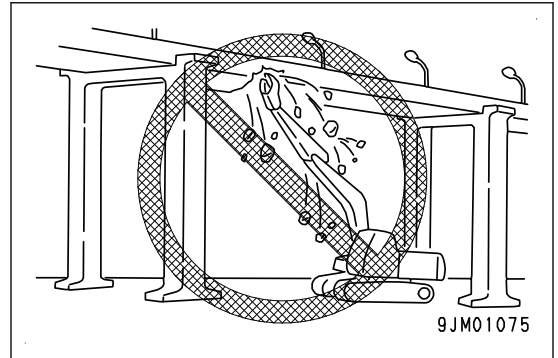

- Do not perform demolition work by using the impact force of the work equipment. Scattered pieces of broken materials, or damage of the work equipment, or the machine tipping over due to reaction from the impact may cause serious personal injury or death.

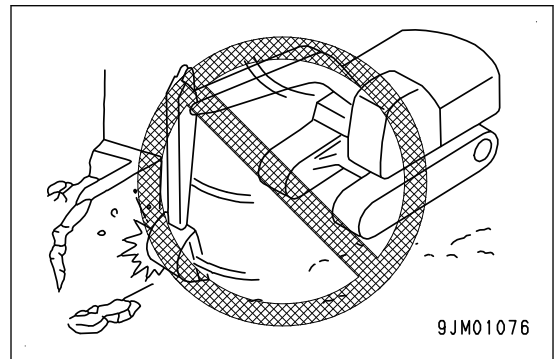

- Do not pass the bucket over the heads of other workers or over the operator's seat of dump trucks or other hauling equipment. There is a danger that the load may spill or the bucket may hit the dump truck and cause serious personal injury or death.
- When working on or from the top of buildings or other structures, check the strength and the structure before starting operations. There is a hazard of the building collapsing and causing serious injury or death.
- Generally speaking, the machine is more liable to tip over when the work equipment is at the side than when it is at the front or rear of the machine. Be extremely careful when swinging the work equipment from the front or rear to the side of machine while it is applied a load. It is dangerous that the machine may tip over.
- When using a breaker or other heavy work equipment, it is dangerous that the machine may lose its balance and tip over. When operating the machine on the flat ground as well as on slopes, observe the following.
  - Do not suddenly lower, swing, or stop the work equipment.
  - Do not suddenly extend or retract the boom cylinder. It is dangerous that the machine may tip over by the impact.



- In the operation using the fork or grapple, do not attempt to pick up an object with the tips.  
The picked up object can easily slip off. Machine may be damaged, or personal injury or death may occur.

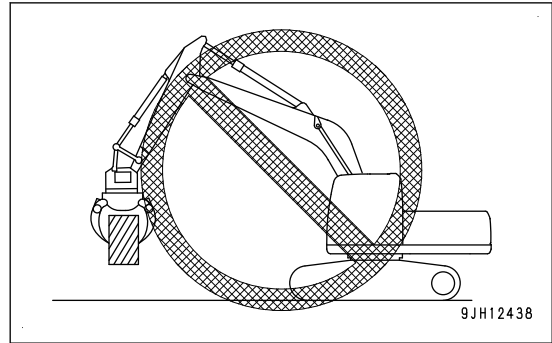

**PRECAUTIONS WHEN OPERATING ON SNOW OR FROZEN SURFACES**

- Snow-covered or frozen surfaces are slippery, so be extremely careful when driving or operating the machine, and do not perform abrupt lever operation. Machine may slip even on a slight slope. Be particularly careful when working on slopes.
- Frozen road becomes soft when the temperature rises, and the machine may tip over or be not able to escape. Be particularly careful when working on frozen road.
- It is dangerous that the machine enters deep snow. The machine may tip over or become buried in the snow. Be careful not to go off the road or to get trapped in a drift of snow.
- When performing snow removal, the road and objects placed beside the road are buried in the snow and cannot be seen.

**PRECAUTIONS WHEN PARKING MACHINE**

Unexpected move of the parked machine can cause serious personal injury or death. Always observe the following.

- Park the machine on a firm, level ground.
- Select a place where there is no hazard of landslides, falling rocks, or flooding.
- Lower the work equipment to the ground.

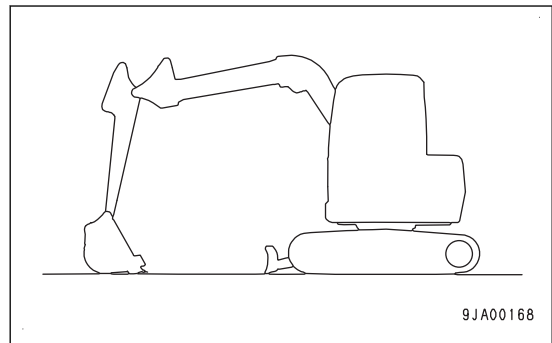

- When leaving the machine, set lock lever (1) to LOCK position (L), then stop the engine.
- Always close the operator's cab door, and use the key to lock all the equipment in order to prevent any unauthorized person from operating the machine. Always remove the key, take it with you, and leave it in the specified place.

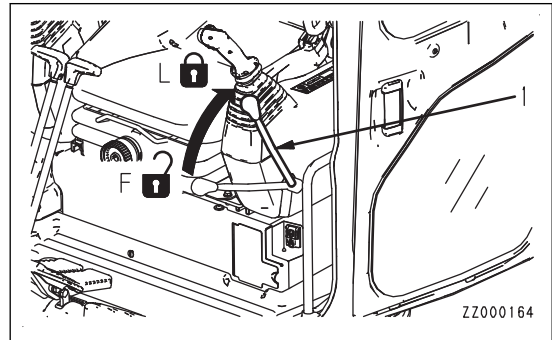

- If it is necessary to park the machine on a slope, always observe the following.
  - Set the work equipment on the downhill side and dig it into the ground.
  - In addition, put blocks under the tracks to prevent the machine from moving.

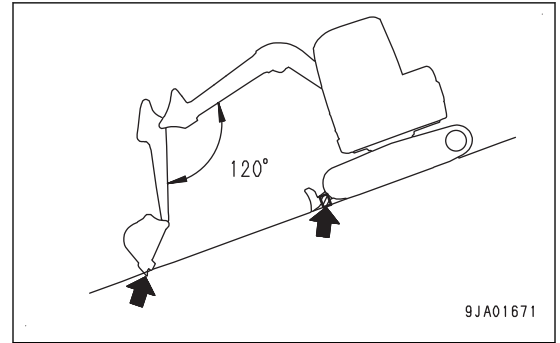

## PRECAUTIONS FOR TRANSPORTATION

When the machine is transported on a trailer, serious personal injury or death may result because of the accident during transportation. Always observe the following.

- Always check the machine dimensions carefully. Depending on the work equipment and optional devices installed, the machine weight, transportation height, and overall length differ.
- Check beforehand that all bridges and other structures on the transportation route are strong enough to withstand the combined weight of the transporter and the machine being transported.
- This machine may need to be divided into components for transportation depending on the regulation. When transporting the machine, consult your Komatsu distributor.

## PRECAUTIONS WHEN LOADING AND UNLOADING

If handling is wrong when loading or unloading the machine, it is dangerous that the machine may tip over or fall. It requires particular attention. Always observe the following.

- Perform loading and unloading on a firm, level ground only. Avoid road edge or place near the cliff.
- Never use the work equipment to load or unload the machine. There is danger that the machine may fall or tip over.
- Always use ramps of adequate strength. Be sure that the ramps are wide, long, and thick enough to provide a safe loading slope. Take suitable steps to prevent the ramps from moving out of position or coming off.

- (1) Chocks
- (2) Ramp
- (3) Center of ramp
- (4) Angle of ramp: Max. 15 °.

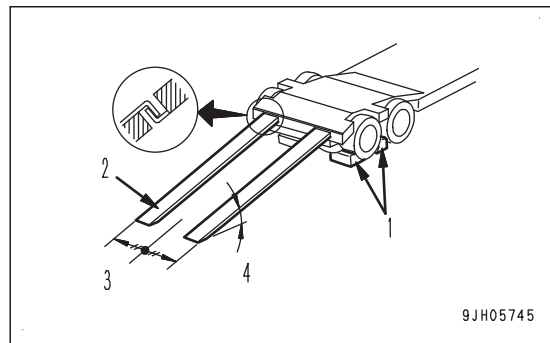

- Be sure the ramp surface and the platform of trailer are clean and free of grease, oil, ice, water and other loose materials. If any, remove them. Remove dirt around the undercarriage of the machine. On a rainy day, in particular, be extremely careful since the ramp surface is slippery.
- Always turn the auto-deceleration switch OFF (cancel). If the machine is operated with the auto-deceleration system ON, there is danger that the engine speed will suddenly rise, the machine will suddenly move off, or the machine travel speed will become faster.
- Run the engine at low idle and drive the machine slowly at low speed.
- When on the ramps, do not operate any lever except for the travel lever (travel forward and reverse).
- Never correct your steering on the ramps. If necessary, drive off the ramps onto the ground, correct the direction, then enter the ramps again.
- The center of gravity of the machine will change suddenly at the joint between the ramps and the loading platform, and there is danger of the machine losing its balance. Drive slowly over this point.
- When loading or unloading to an embankment or platform, make sure that it has suitable width, strength, and grade.
- When swinging the upper structure on the loading platform, lower the work equipment, retract it, and perform the operation slowly.
- Always fold the mirrors and radio antenna.  
For machines equipped with a cab, always lock the door after loading the machine. The door may open during transportation.
- When it is necessary to remove handrails and steps, take care not to lose removed handrails and steps. Install the removed handrails and steps securely.

## TOWING AND BEING TOWED

### PRECAUTIONS FOR TOWING AND BEING TOWED

Always use the correct towing equipment and towing method. Any mistake in the selection of the wire rope or drawbar or the method of towing a disabled machine and being towed may lead to serious personal injury or death.

- Always confirm that the wire rope or drawbar used for towing has ample strength for the weight of the machine being towed.
- Never use the wire rope which has cut strands (A), reduced diameter (B), or kinks (C). There is a danger that the rope may break during the towing operation.
- Always wear leather gloves when handling the wire rope.
- Never tow a machine on a slope.
- During the towing operation, never stand between the towing machine and the machine being towed.

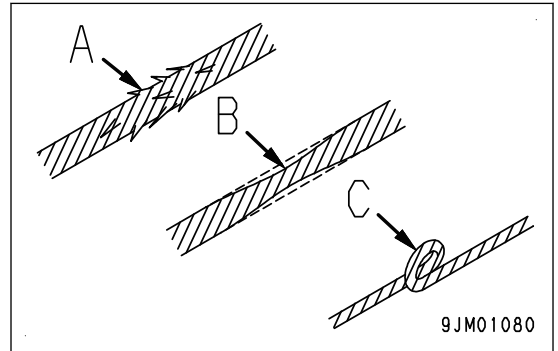

## LIFTING OPERATION BY USING BUCKET WITH HOOK

### PRECAUTIONS FOR LIFTING OPERATIONS

Falling of a lifted load or tipping over of the machine can cause serious personal injury or death. Always observe the following.

- Do not perform lifting work on slopes, soft ground, or other places where the machine is not stable.
- Use wire rope that conforms to the specified standard.
- Determine the signals to be used and place a signalman in position.
- Prohibit anyone to enter into place where there is danger of contact with a raised load or the danger from a falling load.
- It is dangerous if a raised load hits any person or structure. When operating the swing or work equipment, always check carefully that the surrounding area is safe.
- Do not start, swing, or stop the machine suddenly. It is dangerous that the lifted load may swing.
- Do not use the work equipment or swing to pull the load in any direction. There is danger that the hook may break and the load come off, causing the work equipment to move suddenly and cause personal injury.
- Do not leave the operator's seat while the load is being lifted.

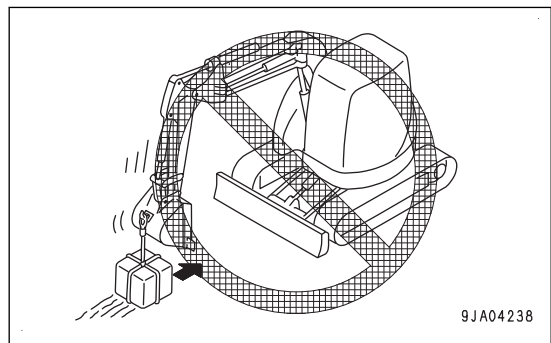
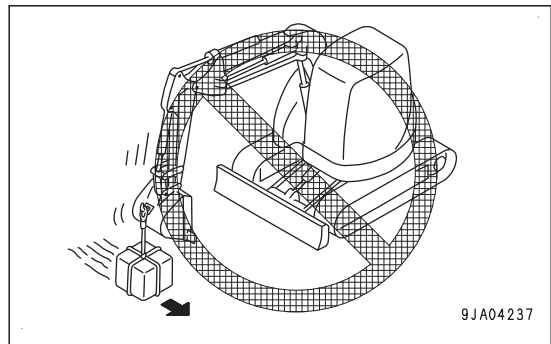

## PRECAUTIONS FOR MAINTENANCE

### PRECAUTIONS BEFORE STARTING INSPECTION AND MAINTENANCE

#### DISPLAY WARNING TAG DURING INSPECTION AND MAINTENANCE

During inspection and maintenance, always display the "DANGER! Do NOT operate!" warning tag.

If there is a "DANGER! Do NOT operate!" warning tag displayed, it means that someone is performing inspection and maintenance of the machine. If the warning tag is ignored and the machine is operated, the person performing inspection or maintenance may be caught in the rotating parts or moving parts. It is dangerous and may cause serious personal injury or death. Do not start the engine or touch the levers.

If necessary, put up signs around the machine as well.

Warning tag part No. 09963-A1640

When not using this warning tag, keep it in the toolbox. If there is no toolbox, keep it in the pocket for Operation and Maintenance Manual

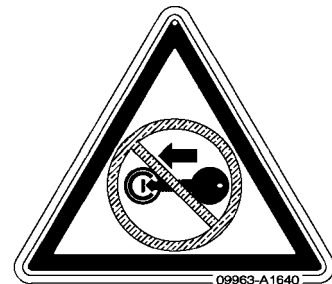
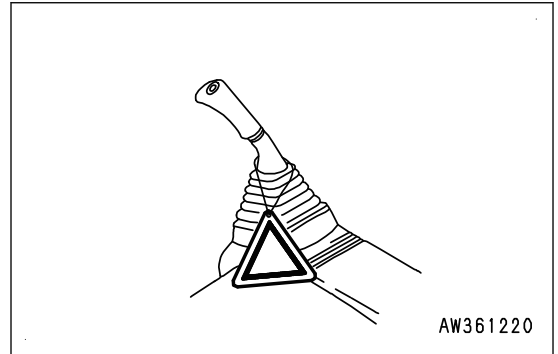

#### KEEP WORK PLACE CLEAN AND TIDY

- Do not leave hammers or other tools lying around in the work place. Wipe up all grease, oil, or other substances that will cause you to slip. Always keep the work place clean and tidy to enable you to perform operations safely. If the work place is not kept clean and tidy, there is the danger that you will trip, slip, or fall over and injure yourself.
- When cleaning the ceiling window which is made of organic glass (polycarbonate), use tap water and avoid use of organic solvents for cleaning. An organic solvent like benzene, toluene or methanol can invite a chemical reaction like dissolution and decomposition on the window glass, deteriorating polycarbonate in use.

#### SELECT SUITABLE PLACE FOR INSPECTION AND MAINTENANCE

- Stop the machine on a firm, level ground.
- Select a place where there is no hazard of landslides, falling rocks, or flooding.

#### ONLY AUTHORIZED PERSONNEL

As long as maintenance of the machine is continued, do not allow unauthorized person to come near the workplace. They might get unexpected personal injury from, for instance, touching machine. Do not allow anyone except the workers concerned to enter the workplace. If necessary, employ a guard.

#### APPOINT LEADER WHEN WORKING WITH OTHERS

When repairing the machine or when removing and installing the work equipment, appoint a leader and follow his/hers instructions during the operation in order to prevent personal injuries caused by being caught or pinched.

### STOP ENGINE BEFORE CARRYING OUT INSPECTION AND MAINTENANCE

If you are caught or pinched between the work equipment during operation, or exposed to high-temperature or high-pressure liquids, it is dangerous and may cause serious personal injury or death. Always observe the following.

- Lower the work equipment completely to the ground and stop the engine before performing any inspection and maintenance.
- Turn the starting switch to ON position. Operate the work equipment control lever back and forth, right and left 2 to 3 times fully to release the remaining internal pressure in the hydraulic circuit. Then move lock lever (1) to LOCK position (L) and turn the starting switch to OFF position.
- Check that the battery relay is off and main power is not conducted. (After turning off the starting switch, wait for approximately 1 minute and press the horn switch. If the horn does not sound, power is not conducted.)
- Put blocks under the track to prevent the machine from moving.

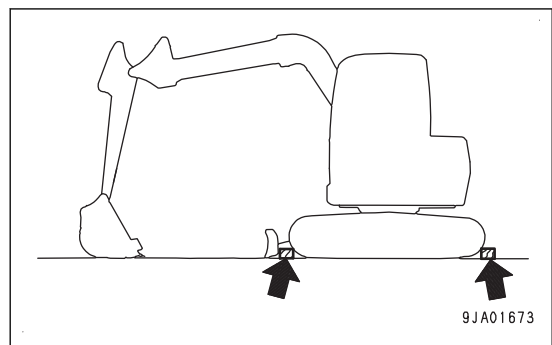
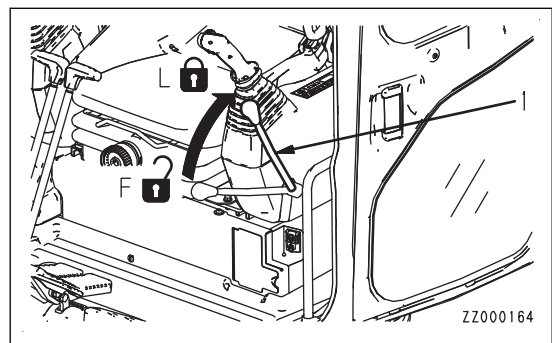
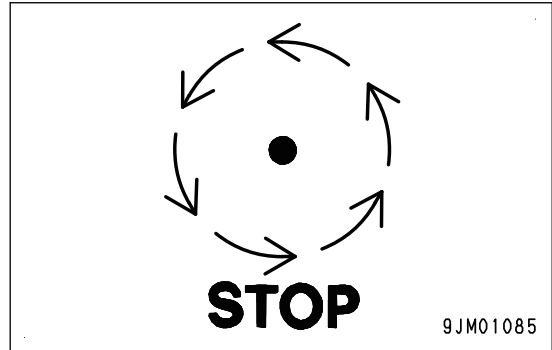

### TWO WORKERS FOR MAINTENANCE WHEN ENGINE IS RUNNING

To prevent personal injury, do not perform maintenance with the engine running. When it is necessary to perform the maintenance with the engine running, always observe the following.

- One worker must always sit in the operator's seat and be ready to stop the engine at any time. All workers must maintain contact with the other workers.
- Rotating parts such as the fan, fan belt are dangerous that they may easily catch a body part or an object someone wears. Be careful not to come close to the rotating part.
- Never drop or insert tools or other objects into the fan, fan belt, or other rotating parts. They may contact the rotating parts and break, and be scattered. It is dangerous.

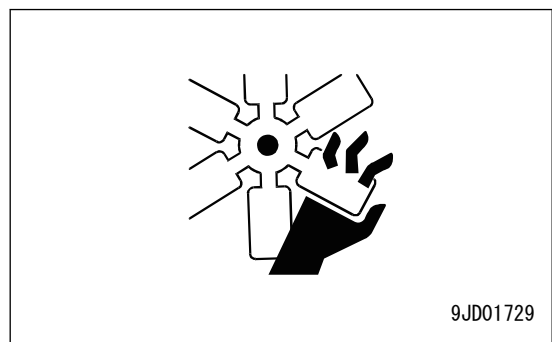

- Release the remaining pressure in the hydraulic system, and place lock lever (1) to LOCK position (L).
- Do not touch the control levers or pedals. When it is necessary to operate the control levers or pedals, always give a signal to your fellow workers to evacuate them to a safe place.

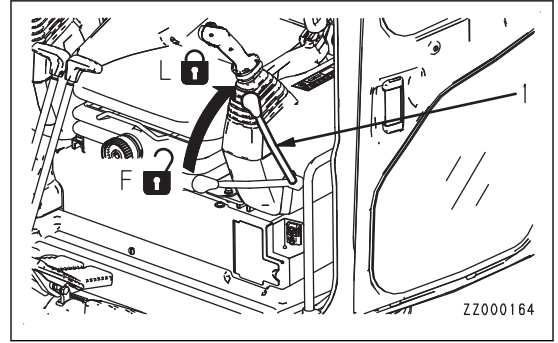

## PRECAUTIONS WHEN INSTALLING, REMOVING, OR STORING ATTACHMENTS

- Appoint a leader before starting removal or installation operations for attachments.
- Place attachments that have been removed from the machine in a stable condition so that they do not fall. And take steps to prevent unauthorized persons from entering the storage area.



## PRECAUTIONS FOR WORKING AT HIGH PLACES

When working at high places, use a step ladder or other stand to ensure that the work can be performed safely. There is a danger falling from high place that can lead to serious personal injury or death.

## PRECAUTIONS WHEN WORKING UNDER MACHINE OR WORK EQUIPMENT

Machine or work equipment may fall, and it is dangerous that serious personal injury or death may occur. Always observe the following.

- Make sure the hoists or hydraulic jacks you use are in good condition and strong enough to handle the weight of the component. Never use hydraulic jacks at places where the machine is damaged, bent, or twisted. Never use if the element wire of wire rope is frayed, twisted or pinched. Never use bent or distorted hooks.
- It is extremely dangerous to work under the machine if the track shoes are lifted off the ground and the machine is supported only with the work equipment. If any of the control levers is touched by accident, or there is damage occurring to the hydraulic piping, the work equipment or the machine will suddenly fall. Never work under the work equipment or the machine.
- If it is necessary to raise the work equipment or the machine and then go under it to perform inspection or maintenance, support the work equipment and machine securely with blocks and stands strong enough to support the weight of the work equipment and machine.

If the work equipment and machine are not supported, they may come down and it may cause serious personal injury or death.

- Never use concrete blocks for supports. Concrete blocks may break under even light loads.





**USE PROPER TOOLS**

Use the tools suited to the task and use them correctly. Using damaged, deformed, or low quality tools, or making improper use of the tools may cause serious personal injury or death.

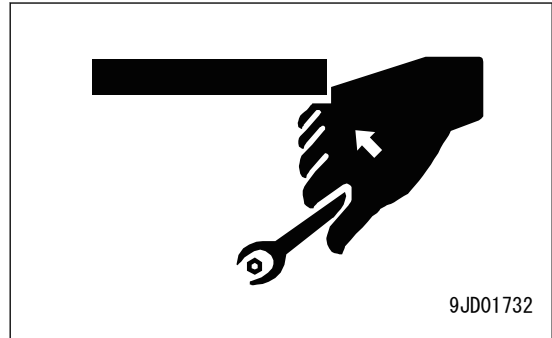

**PRECAUTIONS FOR CHECK AND MAINTENANCE**

**TURN BATTERY DISCONNECT SWITCH TO OFF POSITION**

In the following cases, turn the starting switch to OFF position and check that the system operating lamp is off. Then set the battery disconnect switch to OFF position and remove the switch key.

If you check and handle battery without turning battery disconnect switch to OFF position, serious personal injury or death by such as an electric shock may occur.

- When storing the machine for a long time (more than 1 month)
- When repairing the electrical system
- When performing electric welding
- When handling the battery
- When replacing the fuse, etc.

**PRECAUTIONS FOR WELDING**

Welding operations must always be performed by a qualified welder and in a place equipped with proper equipment. There is a hazard of gas, fire, or electric shock when performing welding, so never allow any unqualified person to perform welding.

**HANDLE BATTERY**

Before inspecting or handling the battery, turn the key in the starting switch to OFF position and check that the system operating lamp is off. Then set the battery disconnect switch to OFF position and remove the switch key.

**Danger of battery exploding**

When the battery is being charged, flammable hydrogen gas is generated and may explode. In addition, the battery electrolyte includes dilute sulphuric acid. Any mistake in handling may cause serious personal injury, explosion, or fire, so always observe the following.

- Do not use or charge the battery if the battery electrolyte is below LOWER LEVEL mark. This may cause an explosion. Always perform periodic inspection of the battery electrolyte level, and add purified water (such as a commercial battery fluid) to UPPER LEVEL mark.
- Do not use a dry wipe to clean the battery. A wet wipe will prevent fire or explosion from static electricity.
- Do not smoke or bring any open flame close to the battery.
- Hydrogen gas is generated when the battery is being charged, so remove the battery from the machine, take it to a well-ventilated place, remove the battery caps, then perform the charging.
- After charging, tighten the battery caps securely.

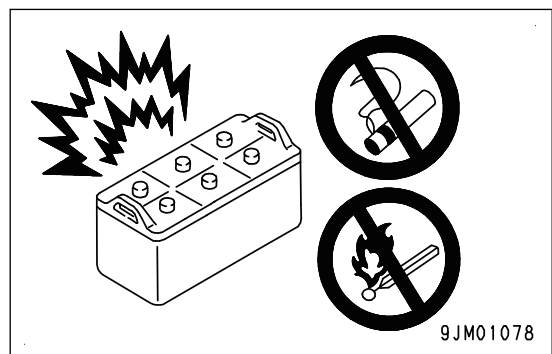

### Danger from dilute sulphuric acid

When the battery is being charged, flammable hydrogen gas is generated and may explode. In addition, the battery electrolyte includes dilute sulphuric acid. Any mistake in handling may cause serious personal injury, explosion, or fire. Always observe the following.

- When handling the battery, always wear protective eye-glasses and rubber gloves.
- If battery electrolyte gets into your eyes, immediately wash your eyes with large amounts of fresh water. After that, get medical attention immediately.
- If battery electrolyte gets on your clothes or skin, wash it off immediately with large amounts of water.

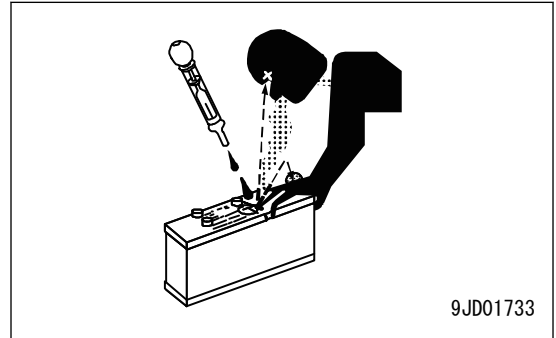

### Danger of sparks

Sparks may be generated and they can cause a fire. Always observe the following.

- Do not let tools or other metal objects make any contact between the battery cables. Do not leave tools lying around near the battery.
- When removing the battery cables, turn the starting switch to OFF position and, after checking that the system operating lamp goes out, set the battery disconnect switch key to OFF position and pull it out. When removing the battery cables, remove the ground cable (negative (-) cable) first. When installing, connect the positive (+) cable first, then connect the ground.
- Tighten the battery cable terminals securely.
- Secure the battery firmly in the specified position.

### PRECAUTIONS WHEN USING HAMMER

When using a hammer, pins may come out or metal particles may be scattered. It is dangerous and may cause serious personal injury or death. Always observe the following.

- When hitting pins or bucket teeth, broken pieces may be scattered, and it may cause personal injury to the people in the surrounding area. Always check that there is no one in the surrounding area.
- If hard metal parts such as pins, bucket teeth, cutting edges, or bearings are hit with a hammer, pieces might be scattered, and it may cause serious personal injury or death. Always wear protective eyeglasses and gloves.
- If the pin is hit with strong force, it may come out, and injure people in the surrounding area. Do not allow anyone to enter the surrounding area.

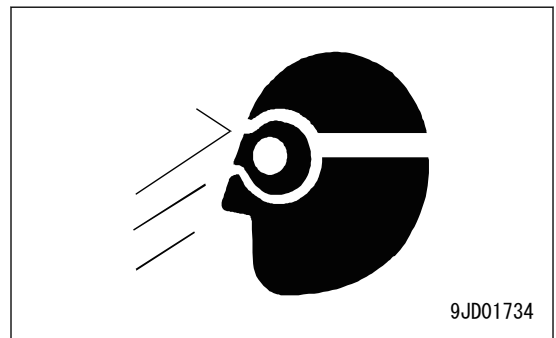

### PRECAUTIONS FOR HIGH-TEMPERATURE COOLANT

To prevent burns from boiling water or steam spurting out when checking or draining the coolant, wait for the coolant to cool down to a temperature where the radiator cap can be touched by hand. Then loosen the cap slowly to release the pressure inside the radiator, and remove the cap.

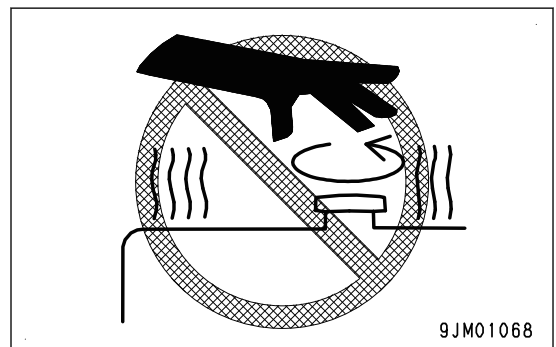

**PRECAUTIONS FOR HIGH-TEMPERATURE OIL**

To prevent burns from hot oil spurting out or from touching high-temperature parts when checking or draining the oil, wait for the oil to cool down to a temperature where the cap or plug can be touched by hand. Then, loosen the cap or plug slowly to release the internal pressure and remove the cap or plug.

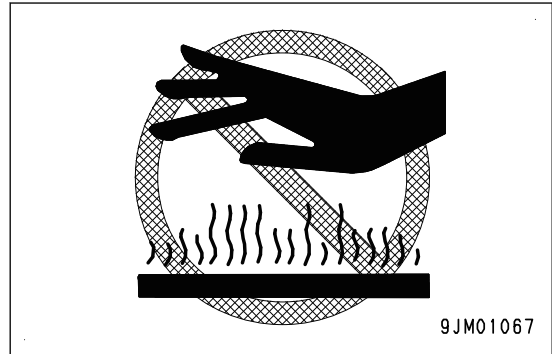

**PRECAUTIONS FOR HIGH-TEMPERATURE PARTS**

To prevent burns from touching high-temperature parts, when checking or performing maintenance after stopping engine, check the parts have been cooled down to touch with bare hand before checking or maintenance.

**PRECAUTIONS FOR HIGH-PRESSURE OIL**

The hydraulic system is always under internal pressure. In addition, the fuel piping is also under internal pressure when the engine is running and immediately after the engine is stopped. When performing inspection or replacement of the piping or hoses, check that the internal pressure in the circuit has been released. If this is not done, serious personal injury or death may result. Always observe the following.

- Do not perform inspection or replacement work with the circuit under pressure.
- If there is any leakage from the piping or hoses, the surrounding area may be wet, so check for cracks in the piping and hoses and for swelling in the hoses.  
When performing inspection, wear protective equipment such as protective eyeglasses and leather gloves.
- High-pressure oil leaking from small holes is dangerous that may penetrate your skin and cause loss of sight if it contacts your skin or eyes directly. If a jet of high-pressure oil hit your skin or eyes, and suffer injury, wash the place with clean water, and consult a doctor immediately for medical attention.

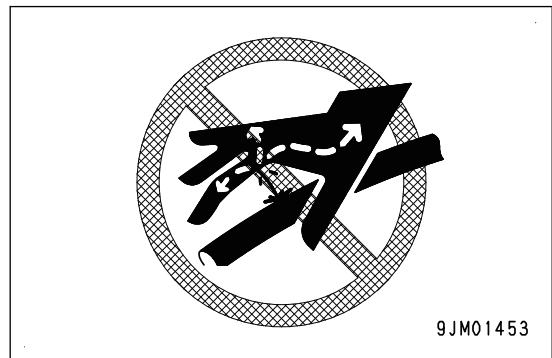

**PRECAUTIONS FOR HIGH-PRESSURE FUEL**

While the engine is running, high-pressure is generated in the engine fuel piping. If you try to disassemble the piping before the internal pressure is released, serious personal injury or death can result. When performing inspection or maintenance of the fuel piping system, stop the engine and wait for at least 30 seconds to allow the internal pressure to go down before starting the work.

## HANDLE HIGH-PRESSURE HOSES AND PIPING

If oil or fuel leaks from high-pressure hoses or piping, it may cause fire or defective operation. It is dangerous and may cause serious personal injury or death. If the hose or piping mounts are loose or oil or fuel is found to be leaking from the mount, stop operations and tighten to the specified torque.

If any damaged or deformed hoses or piping are found, consult your Komatsu distributor.

Replace the hose if any of the following problems are found.

- Damaged hose or deformed hydraulic fitting.
- Frayed or cut covering or exposed reinforcement wire layer.
- Covering swollen in places.
- Twisted or crushed movable portion.
- Foreign material embedded in covering.

## PRECAUTIONS FOR HIGH VOLTAGE

When the engine is running and immediately after it is stopped, high voltage is generated inside the engine controller and the engine injector, and there is danger of electric shock. Never touch the inside of the engine controller or the injector part of the engine. If it is necessary to touch the inside of the engine controller or the injector part of the engine, consult your Komatsu distributor.

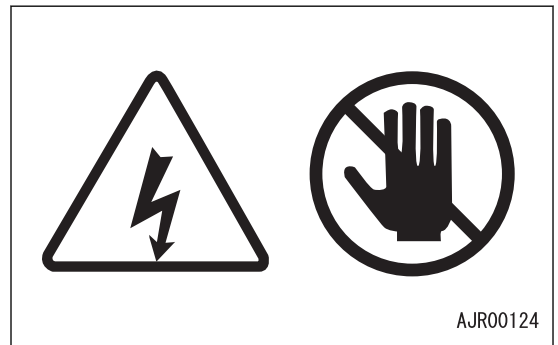

## PRECAUTIONS FOR NOISE

When performing maintenance of the engine and you are exposed to noise for long periods of time, wear ear covers or ear plugs while working.

If the noise is too loud, it may cause temporary or permanent hearing problems.

## PRECAUTIONS FOR HIGH-PRESSURE GREASE WHEN ADJUSTING TRACK TENSION

- Grease is pumped into the track tension adjustment system under high pressure. If the specified procedure for maintenance is not followed when making adjustment, grease drain plug (1) may fly out and cause serious injury or property damage.
- When loosening grease drain plug (1) to loosen the track tension, never loosen it more than 1 turn. Loosen the grease drain plug slowly.
- Never put your face, hands, feet, or any other part of your body close to grease drain plug (1).

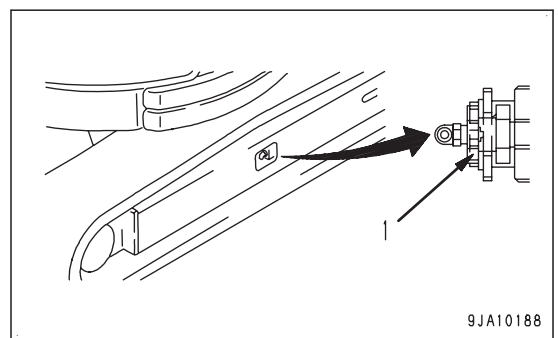

### DO NOT DISASSEMBLE RECOIL SPRING

Never disassemble the recoil spring assembly.

The recoil spring assembly has a powerful spring that acts to reduce the impact on the idler. If it is disassembled by mistake, the spring may shoot out and cause serious personal injury or death. If it is necessary to disassemble it, ask your Komatsu distributor to perform the work.

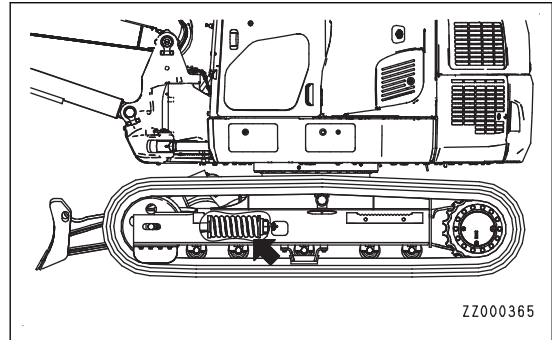

### HANDLE ACCUMULATOR AND GAS SPRING

This machine is equipped with an accumulator. Even after the engine stops, if the work equipment control lever is operated after stop of the engine in the direction to lower the work equipment, the work equipment goes down with its own weight.

After stopping the engine, set the lock lever to LOCK position.

The accumulator and gas spring are charged with high-pressure nitrogen gas. If the accumulator is handled mistakenly, it may cause an explosion. It is dangerous and may cause serious personal injury or death. Always observe the following.

- Do not disassemble.
- Do not bring it near flame or dispose of it in fire.
- Do not make holes in it, weld it, nor use a cutting torch.
- Do not hit or roll the accumulator, or subject it to any impact.
- When disposing of the accumulator, the gas must be released. Ask your Komatsu distributor to perform this work.



### PRECAUTIONS FOR COMPRESSED AIR

- When performing cleaning with compressed air, there is a hazard of serious personal injury or death caused by flying dust or particles.
- When using compressed air to clean the filter element or radiator, wear protective eyeglasses, anti-dust mask, gloves, and other protective equipment.

### MAINTENANCE OF AIR CONDITIONER

If air conditioner refrigerant gets into your eyes, it may cause loss of sight; if it contacts your skin, it may cause frostbite. Never loosen any parts of the cooling circuit.

## PRECAUTIONS FOR DISPOSING OF WASTE MATERIALS

To prevent pollution, pay full attention to the way to dispose of waste materials.

- Always drain the oil from your machine in containers. Never drain the oil and coolant directly onto the ground or dump into the sewage system, rivers, seas, or lakes.
- Obey appropriate laws and regulations when disposing of harmful objects such as oil, fuel, coolant, solvent, filters, and batteries.

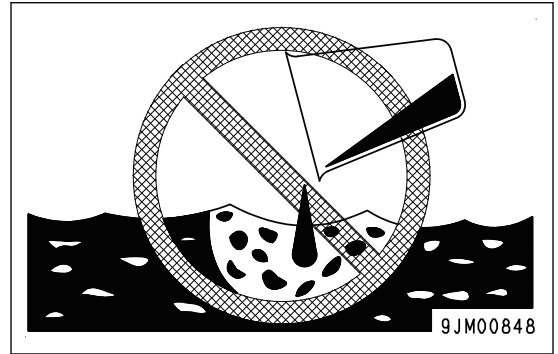

Avoid exposure to burning rubber or plastics which produce a toxic gas that is harmful to people.

- When disposing of parts made of rubber or plastics (hoses, cables, and harnesses), always comply with the local regulations for disposing industrial waste products.

## METHOD FOR SELECTING WINDOW WASHER FLUID

Use an ethyl alcohol base washer liquid.

Methyl alcohol base washer liquid may irritate your eyes, so do not use it.

## PERIODIC REPLACEMENT OF DEFINED LIFE PARTS

- For using the machine safely for a long period, always perform periodic replacement of defined life parts that have a particularly close relation to safety, such as hoses and the seat belt.  
Replacement of defined life parts: See REPLACEMENT PARTS, "PERIODIC REPLACEMENT OF DEFINED LIFE PARTS"
- The material of these components naturally changes over time, and repeated use causes deterioration, wear, and fatigue. As a result, there is a hazard that these components may fail and cause serious personal injury or death. It is difficult to judge the remaining life of these components from external inspection or the feeling when operating, so always replace them at the specified interval.
- Replace or repair defined life parts if any defect is found, even when they have not reached the specified replacement time.



# OPERATION

## **WARNING**

Please read and make sure that you understand the SAFETY section before reading this section.

---



# GENERAL VIEW

## MACHINE EQUIPMENT NAME

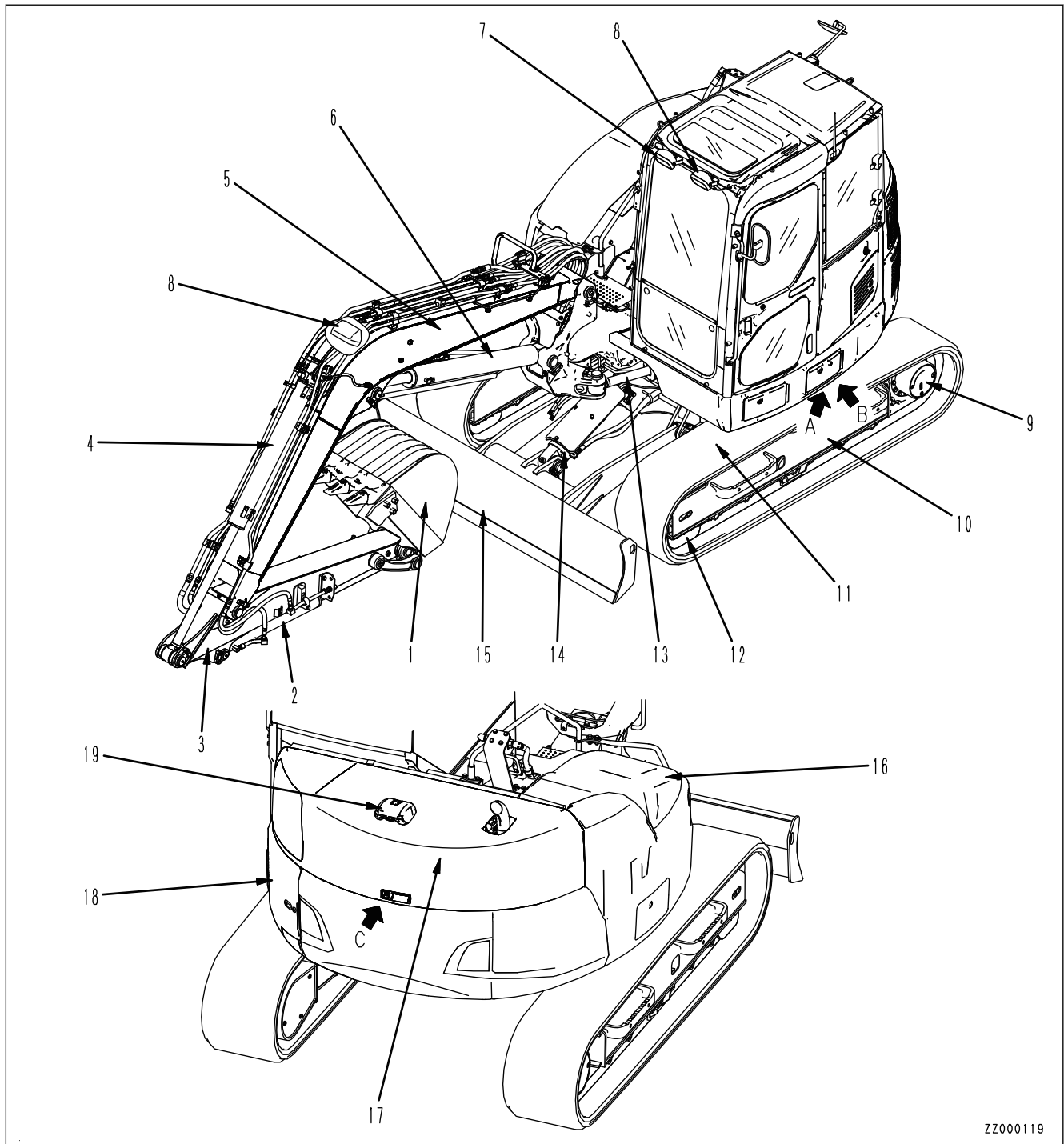

ZZ000119

- (1) Bucket
- (2) Bucket cylinder
- (3) Arm
- (4) Arm cylinder
- (5) Boom
- (6) Boom cylinder
- (7) Additional lamp (if equipped)
- (8) Working lamp
- (9) Sprocket
- (10) Track frame
- (11) Track
- (12) Idler
- (13) Boom swing cylinder
- (14) Blade cylinder

- (15) Blade
- (16) Dirt cover
- (17) Engine hood

- (18) Battery inspection cover
- (19) Rear view camera

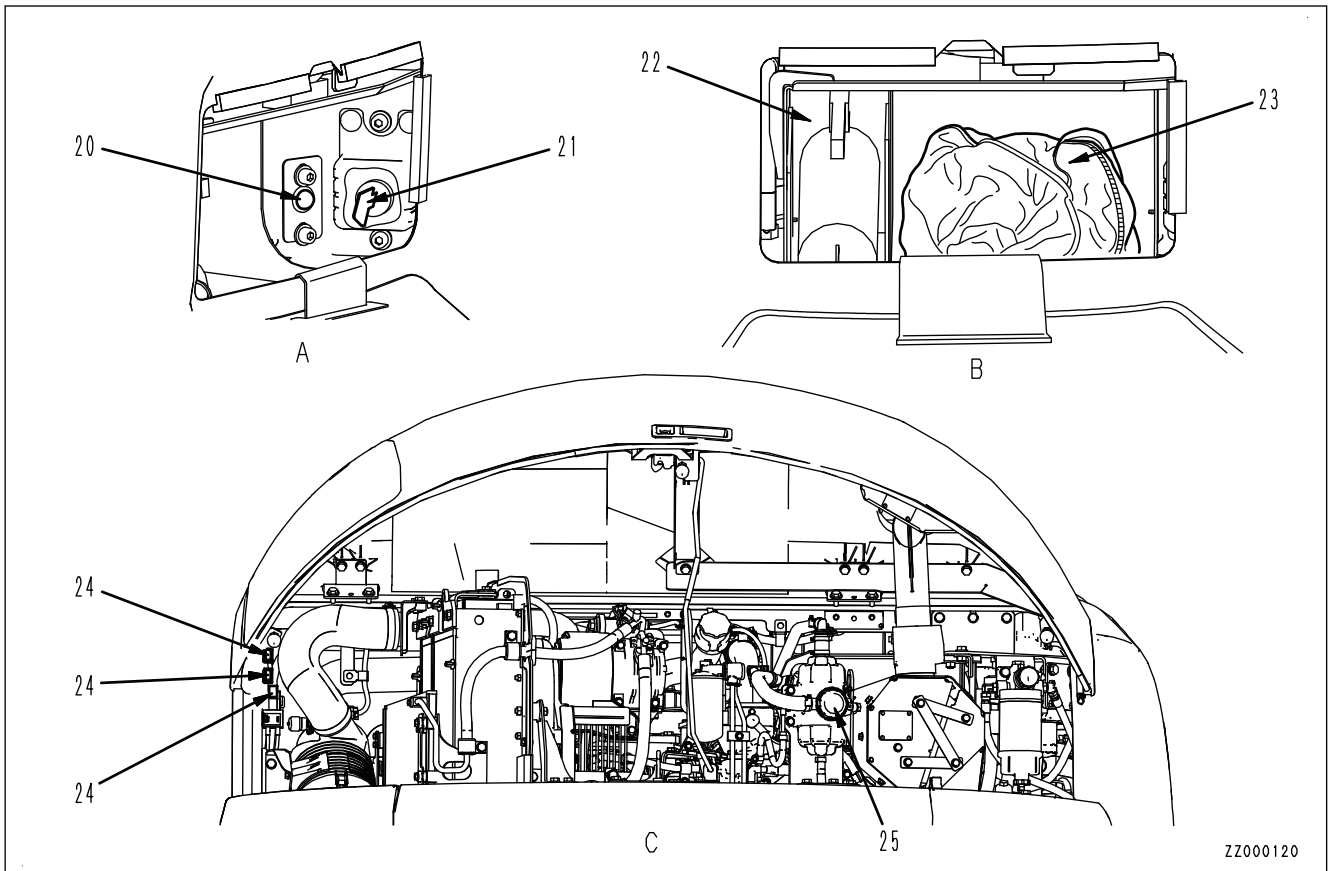

- (20) System operation lamp
- (21) Battery disconnect switch
- (22) Grease pump holder
- (23) Toolbox

- (24) Fusible link
- (25) Komatsu Closed Crankcase Ventilation (hereafter KCCV) ventilator

## CAB EQUIPMENT NAMES

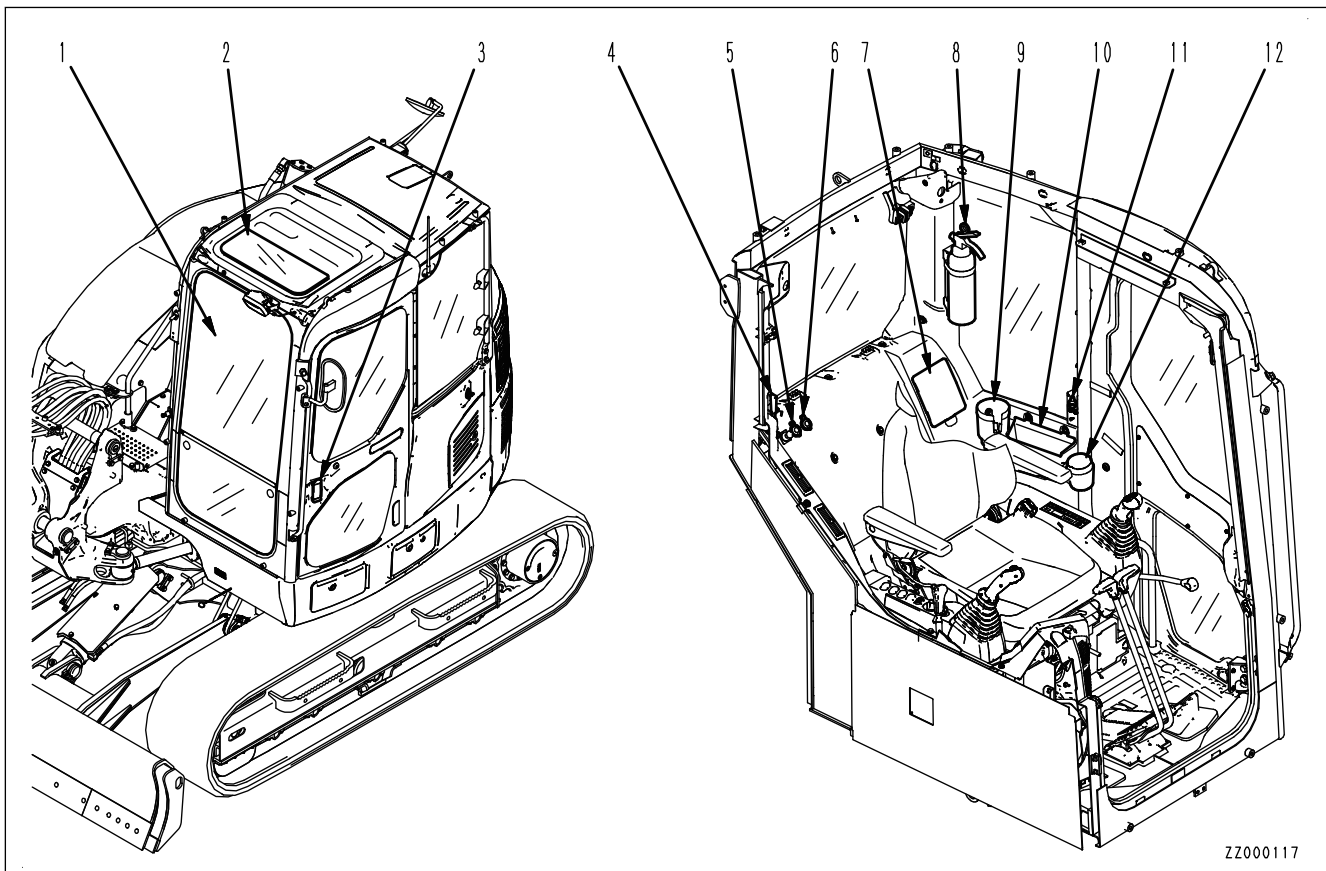

- (1) Front window
- (2) Ceiling window
- (3) Door handle
- (4) Emergency escape hammer
- (5) 12 V Power supply 1
- (6) 12 V Power supply 2

- (7) Fuse
- (8) Fire extinguisher (if equipped)
- (9) Cup holder
- (10) Magazine box
- (11) AUX
- (12) Ashtray

**CONTROLS AND GAUGES NAMES**

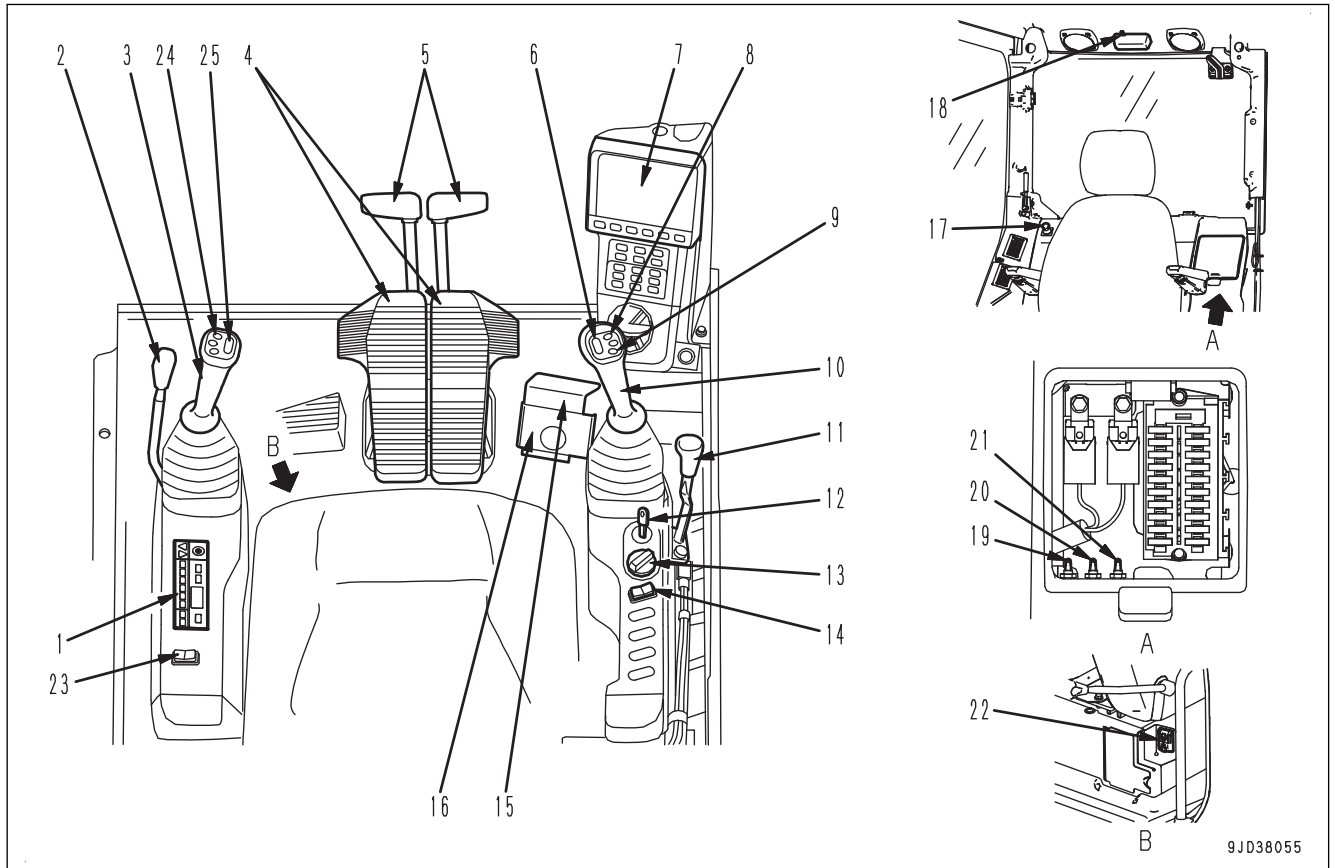

- |   |  |
|---|--|
| (1) Radio                                   | (14) Lamp switch                             |
| (2) Lock lever                              | (15) Swing lock cover                        |
| (3) L.H. work equipment control lever       | (16) Boom swing control pedal                |
| (4) Travel pedal                            | (17) Cigarette lighter                       |
| (5) Travel lever                            | (18) Room lamp switch                        |
| (6) 1st-line attachment proportional switch | (19) Pump secondary drive switch             |
| (7) Machine monitor                         | (20) Swing parking brake cancel switch       |
| (8) Breaker control switch                  | (21) Lock lever automatic lock cancel switch |
| (9) Horn switch                             | (22) Engine shutdown secondary switch        |
| (10) R.H. work equipment control lever      | (23) Quick coupler main switch               |
| (11) Blade control lever                    | (24) Quick coupler operation switch          |
| (12) Starting switch                        | (25) 2nd-line attachment proportional switch |
| (13) Fuel control dial                      |  |

**MACHINE MONITOR EQUIPMENT NAME**

The display method of the monitor is partly different when the machine is not equipped with the rearview camera. For details, see ATTACHMENTS AND OPTIONS, "MACHINE MONITOR EQUIPMENT NAME".

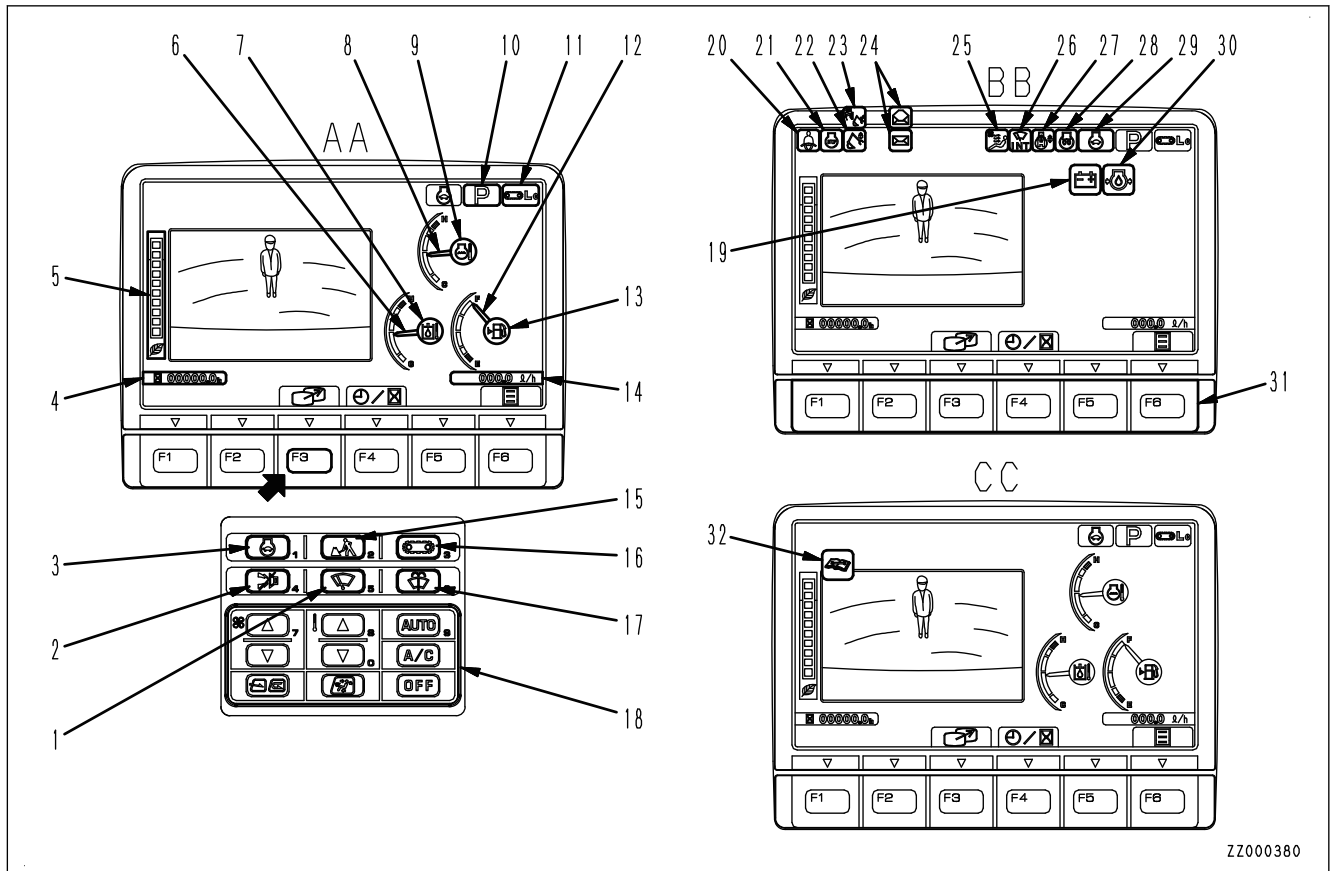

AA: Standard screen, BB: Check before starting screen, CC: Maintenance time warning screen

- |   |   |
|---|---|
| (1) Wiper switch                            | (17) Window washer switch                         |
| (2) Buzzer cancel switch                    | (18) Air conditioner control switch               |
| (3) Auto-deceleration switch                | (19) Charge level caution lamp                    |
| (4) Service meter/clock                     | (20) Seat belt caution lamp                       |
| (5) ECO gauge                               | (21) Engine stop pilot lamp                       |
| (6) Hydraulic oil temperature gauge         | (22) Work equipment lock pilot lamp               |
| (7) Hydraulic oil temperature caution lamp  | (23) Lock lever automatic lock release pilot lamp |
| (8) Engine coolant temperature gauge        | (24) Message display                              |
| (9) Engine coolant temperature caution lamp | (25) Air conditioner pilot lamp                   |
| (10) Working mode display                   | (26) Wiper pilot lamp                             |
| (11) Travel speed display                   | (27) Swing lock pilot lamp                        |
| (12) Fuel gauge                             | (28) Preheating pilot lamp                        |
| (13) Fuel level caution lamp                | (29) Auto-deceleration pilot lamp                 |
| (14) Fuel consumption gauge                 | (30) Engine oil pressure caution lamp             |
| (15) Working mode selector switch           | (31) Function switches (F1 to F6)                 |
| (16) Travel speed selector switch           | (32) Maintenance time caution lamp                |

**REMARK**

The above figure does not show all of the caution lamp symbols.

### Displaying only meter

On the standard screen (camera display, meter display), press switch F3, and only the meter is displayed. For detail, see "CAMERA IMAGE SELECTOR SWITCH".

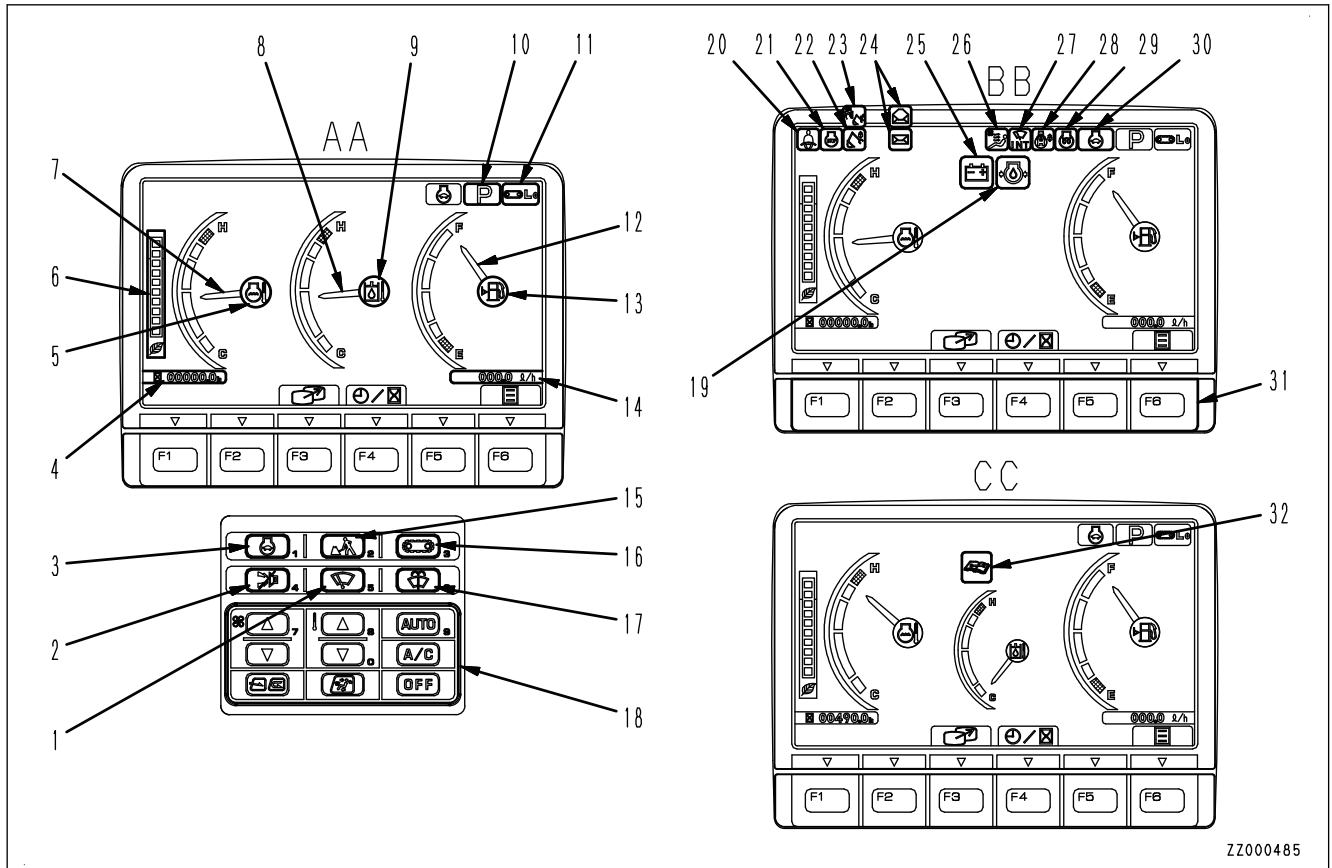

AA: Standard screen, BB: Check before starting screen, CC: Maintenance time warning screen

- |   |   |
|---|---|
| (1) Wiper switch                            | (17) Window washer switch                         |
| (2) Buzzer cancel switch                    | (18) Air conditioner control switch               |
| (3) Auto-deceleration switch                | (19) Engine oil pressure caution lamp             |
| (4) Service meter/clock                     | (20) Seat belt caution lamp                       |
| (5) Engine coolant temperature caution lamp | (21) Engine stop pilot lamp                       |
| (6) ECO gauge                               | (22) Work equipment lock pilot lamp               |
| (7) Engine coolant temperature gauge        | (23) Lock lever automatic lock release pilot lamp |
| (8) Hydraulic oil temperature gauge         | (24) Message display                              |
| (9) Hydraulic oil temperature caution lamp  | (25) Charge level caution lamp                    |
| (10) Working mode display                   | (26) Air conditioner pilot lamp                   |
| (11) Travel speed display                   | (27) Wiper pilot lamp                             |
| (12) Fuel gauge                             | (28) Swing lock pilot lamp                        |
| (13) Fuel level caution lamp                | (29) Preheating pilot lamp                        |
| (14) Fuel consumption gauge                 | (30) Auto-deceleration pilot lamp                 |
| (15) Working mode selector switch           | (31) Function switches (F1 to F6)                 |
| (16) Travel speed selector switch           | (32) Maintenance time caution lamp                |

**REMARK**

The above figure does not show all of the caution lamp symbols.

# EXPLANATION OF COMPONENTS

The following is an explanation of devices necessary to operate the machine.

To perform suitable operations correctly and safely, it is important to completely understand methods of operating the equipment, and the meanings of the displays.

## EXPLANATION OF MACHINE MONITOR EQUIPMENT

The display method of the monitor is partly different when the machine is not equipped with the rearview camera. For details, see ATTACHMENTS AND OPTIONS, "EXPLANATION OF MACHINE MONITOR EQUIPMENT".

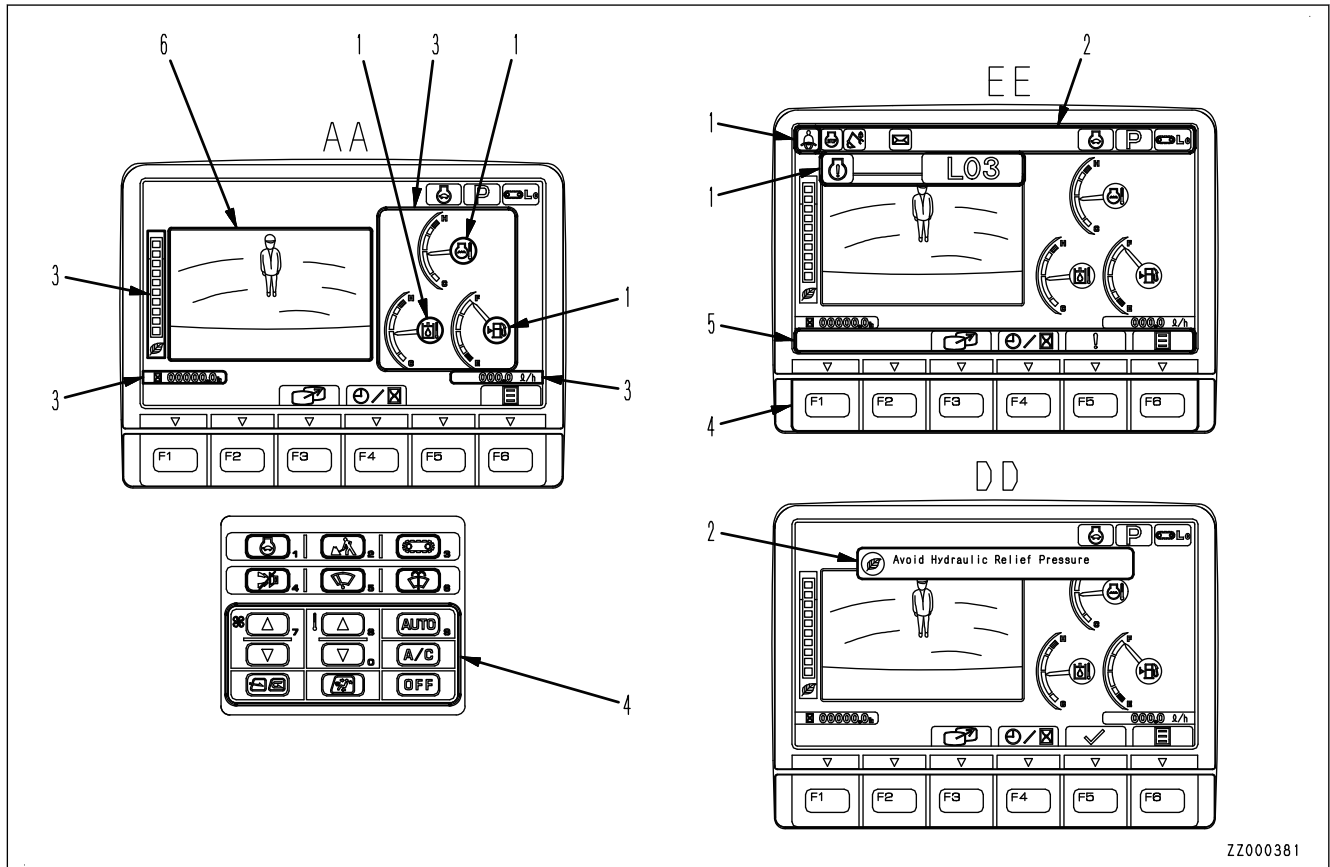

ZZ000381

AA: Standard screen, EE: Warning or Error screen, DD: Guidance screen

- (1) Warning display
- (2) Pilot display
- (3) Meter display
- (4) Monitor switch area
- (5) Guidance icon display
- (6) Camera image display

**REMARK**

- If environmental temperature of the machine monitor is high, brightness may be automatically reduced to protect the liquid crystal.
- Intensity or color of the objects may change because of the automatic adjustment function of the camera.

### Displaying only meter

On the standard screen (camera display, meter display), press switch F3, and only the meter is displayed.  
 For detail, see "CAMERA IMAGE SELECTOR SWITCH".

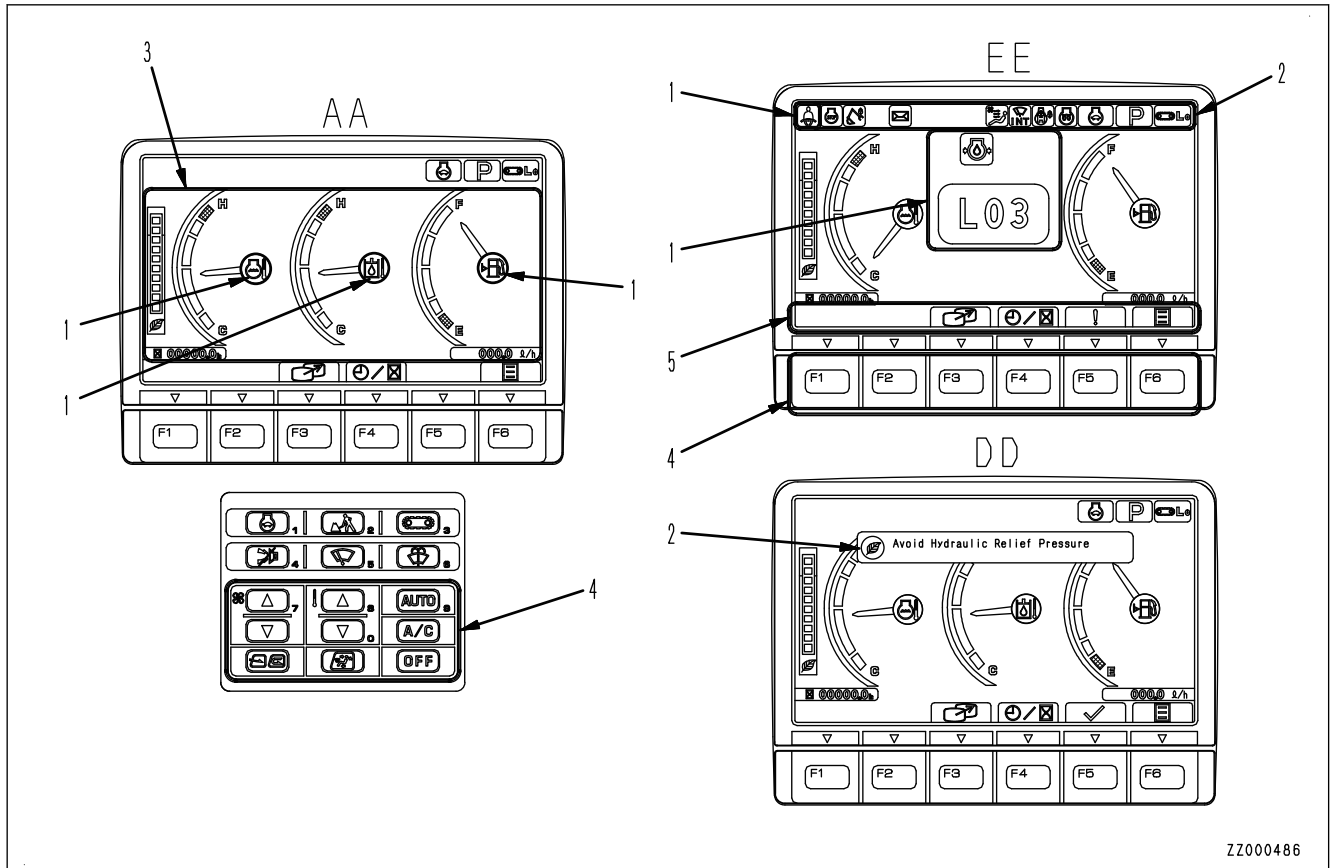

ZZ000486

AA: Standard screen, EE: Warning or Error screen, DD: Guidance screen

- (1) Warning display
- (2) Pilot display
- (3) Meter display
- (4) Monitor switch area
- (5) Guidance icon display

#### REMARK

- If environmental temperature of the machine monitor is high, brightness may be automatically reduced to protect the liquid crystal.
- Intensity or color of the objects may change because of the automatic adjustment function of the camera.



## BASIC OPERATION OF MACHINE MONITOR

### BASIC OPERATION OF MACHINE MONITOR WHEN STARTING ENGINE IN NORMAL SITUATION

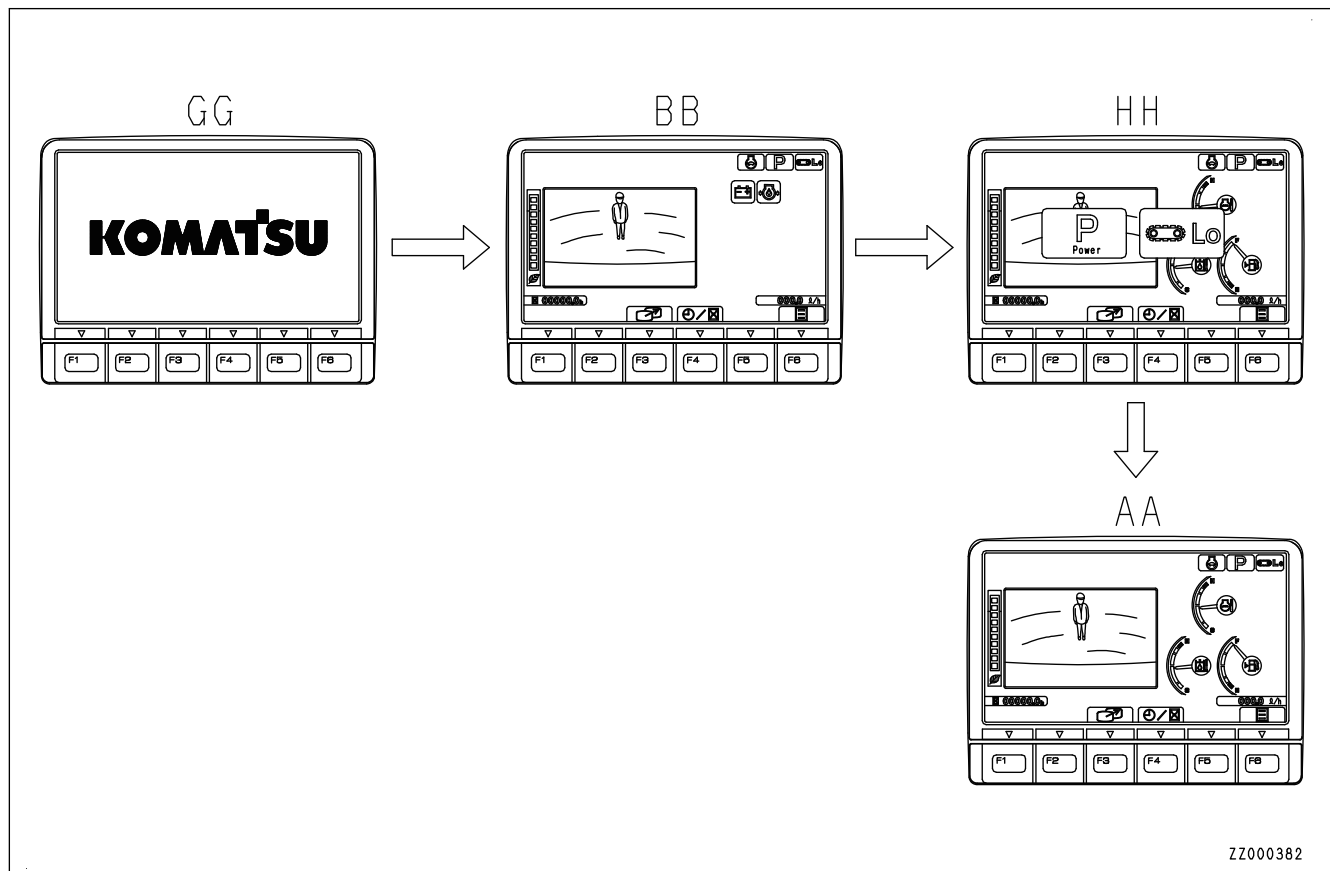

- When the starting switch is turned to ON position, the opening screen GG is displayed.
- After the opening screen GG is displayed for 2 seconds, the screen switches to the check before starting screen BB.
- After the check before starting screen BB is displayed for 2 seconds, the screen switches to the working mode/ travel mode display screen HH.
- After the working mode/ travel mode display screen HH is displayed for 2 seconds, the screen switches to standard screen AA.

#### REMARK

- When the engine is started, the battery voltage may suddenly drop depending on the temperature and the battery condition. If this happens, the machine monitor may restart, but this does not indicate any abnormality.

### BASIC OPERATION OF MACHINE MONITOR WHEN STARTING ENGINE WHILE ENGINE SHUTDOWN SECONDARY SWITCH IS ON

While engine shutdown secondary switch (1) is ON (engine is stopped), when the starting switch is turned to ON position, the screen shown in the figure is displayed and engine does not start.

If engine shutdown secondary switch (1) is turned OFF (normal), the machine monitor switches to the standard screen, and the engine can be started with usual starting switch key operation.

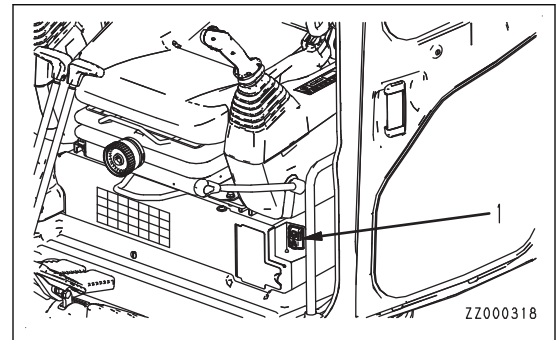
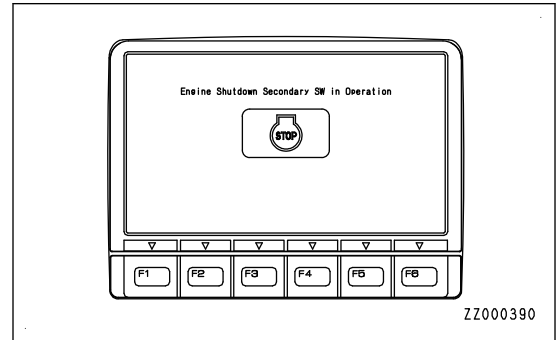

### BASIC OPERATION OF MACHINE MONITOR WHEN STOPPING ENGINE IN NORMAL SITUATION

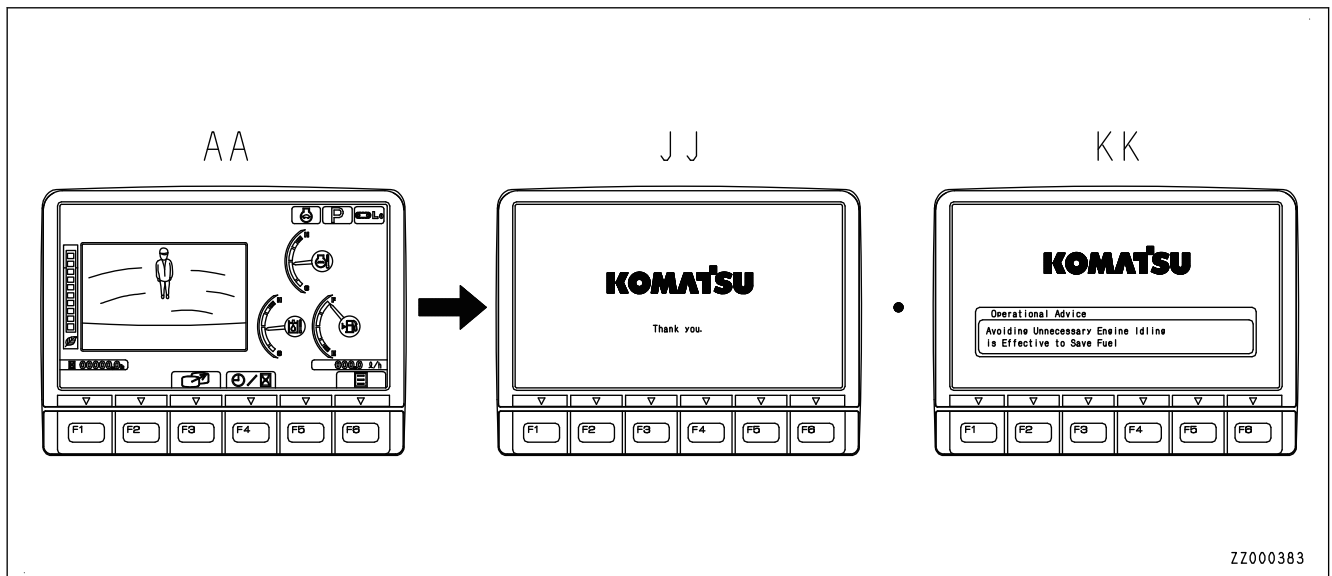

When the starting switch is turned to OFF position, end screen JJ or KK is displayed for 5 seconds, then the display goes out.

### End screen when any message has been received

If there is any message from your Komatsu distributor, it is displayed on the end screen.

In this case, turn the starting switch to ON position to re-check the message, and if it is the message requesting response, send back your reply.

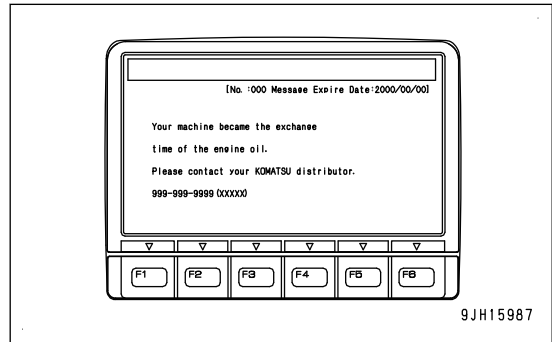

### BASIC OPERATION OF MACHINE MONITOR WHEN STARTING SWITCH IS ON WHILE OPERATOR ID INPUT IS SET

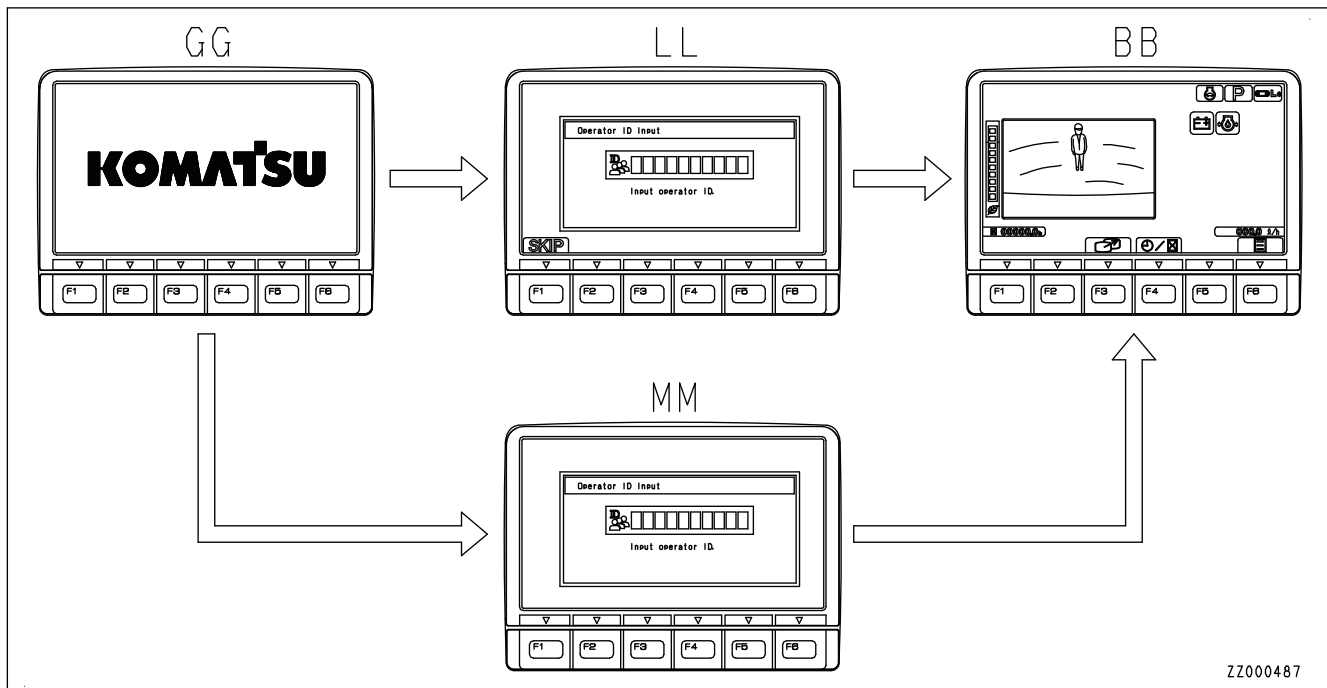

- If “ID Number Input (with SKIP)” for “Operator ID Setting” is set, the opening screen GG switches to “Operator ID Input” (with SKIP) when the starting switch is turned to ON position.
- If “ID Number Input (without SKIP)” for “Operator ID Setting” is set, the opening screen GG switches to “Operator ID Input” (without SKIP) when the starting switch is turned to ON position.
- On “Operator ID Input” (with SKIP) screen LL or “Operator ID Input” (without SKIP) screen MM, input the already registered ID number, and press switch F6. The screen changes to Check Before Starting screen BB. If you input an incorrect ID number, press switch F5, and clear an input character at a time.

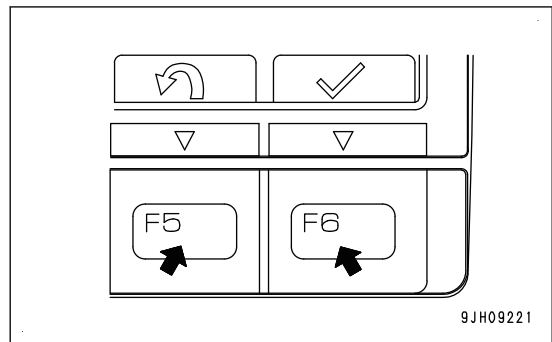

On “Operator ID Input” screen LL (with SKIP), press switch F1, and the screen changes to Check Before Starting screen BB without inputting ID number.

**REMARK**

- Contact your Komatsu distributor for details of the method of setting, changing, or canceling the operator identification function.
- Depending on the set value of “Operator ID Holding Time with Key OFF” for Operator ID Function Setting function, even when operator ID of “Operator ID Setting” has been inputted, “Operator ID Input” (with SKIP) screen LL or “Operator ID Input” (without SKIP) MM screen may not be displayed when the starting switch is turned to ON position.

If inputting incorrect ID number for 3 times continuously, you cannot input ID number for 5 minutes. Wait for more than 5 minutes, try inputting ID number again.

As long as “Operator ID Input” screen is displayed, the engine cannot be started. If you forget the ID number and cannot start the engine, confirm the person in charge of the machine.

**NOTICE**

**Since the purpose of the operator identification function is neither security enhancement nor a protection against theft, it has no anti-theft effect. Be careful not to use it for the purpose of security enhancement.**

**Komatsu cannot accept any responsibility for any loss or damage resulting from the wrong use of ID or unauthorized use of ID by a third person.**

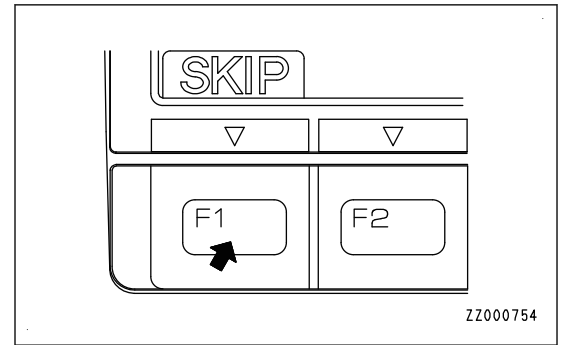

**BASIC OPERATION OF MACHINE MONITOR WHEN STARTING ENGINE IN ABNORMAL SITUATION**

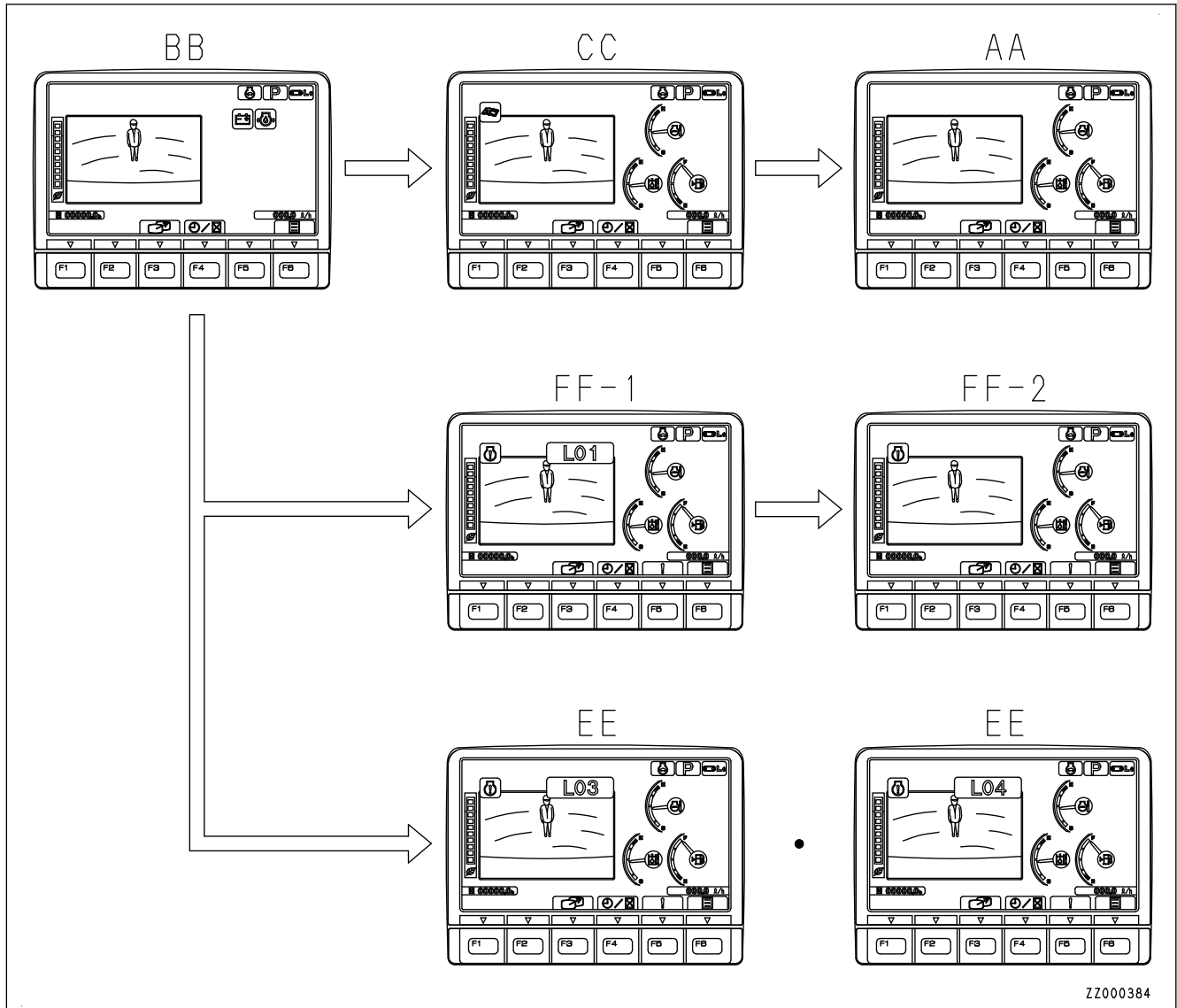

- If there is any abnormality when starting the engine, the check before starting screen BB changes to the maintenance time warning screen CC, warning screen FF, or error screen EE.
- After displaying the checks before starting screen BB for 2 seconds, the screen changes to the maintenance time warning screen CC.
- After displaying the maintenance time warning screen CC for 30 seconds, the screen returns to the standard screen AA.
- After displaying the checks before starting screen BB for 2 seconds, the screen changes to the warning screen FF or error screen EE.

If there is any error existing, "!" is displayed on top of switch F5.  
 Press switch F5 to check the detail of the error. Current abnormality screen is displayed.

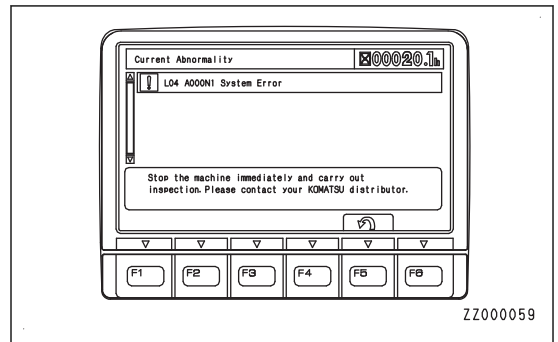
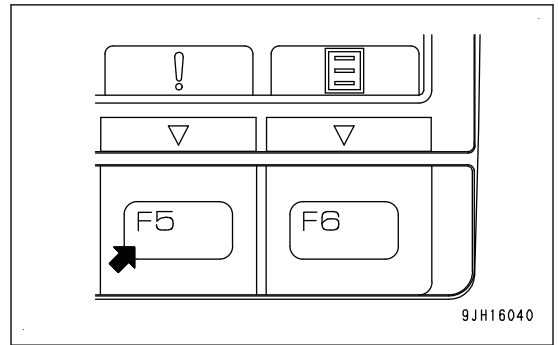

**BASIC OPERATION OF MACHINE MONITOR WHEN TROUBLE OCCURS WHILE OPERATING MACHINE**

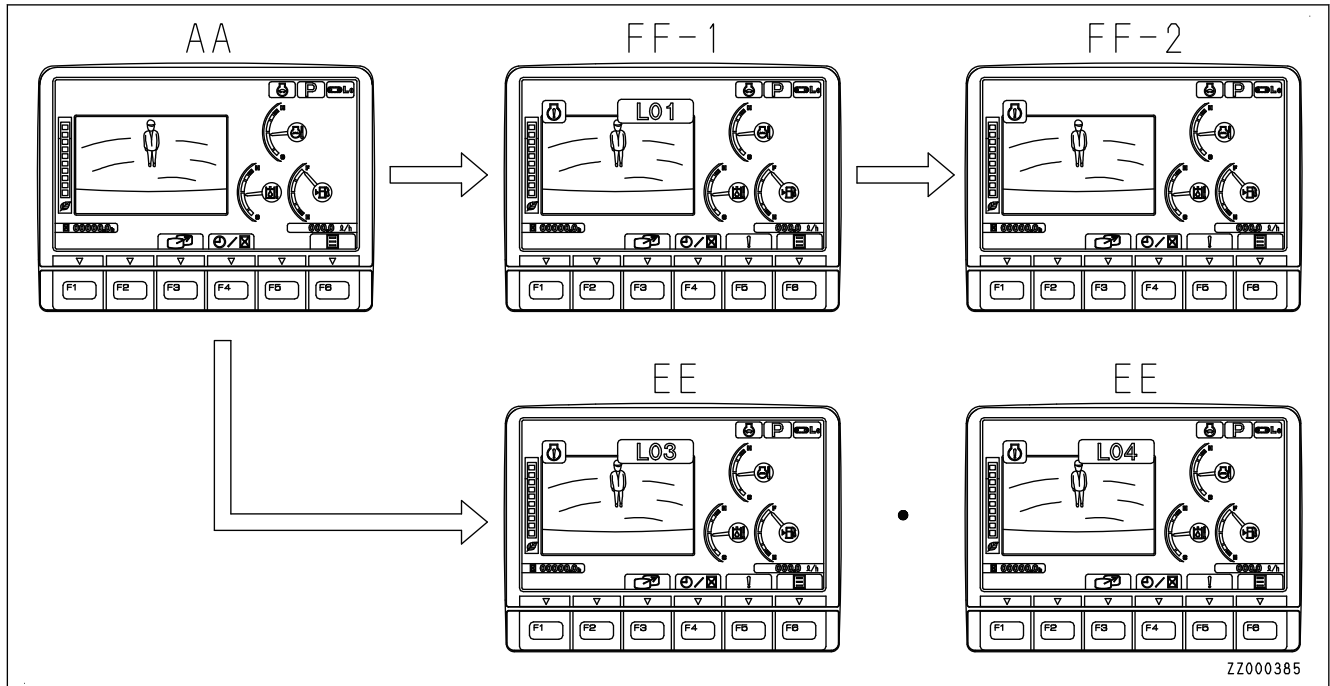

ZZ000385

- If any abnormality occurs during operation, the standard screen AA changes to warning screen FF-(1) or the error screen EE.
- After displaying warning screen FF-(1) for 2 seconds, the screen automatically changes to warning screen FF-(2).

If there is any error existing, “!” is displayed on top of switch F5. Press switch F5 to check the detail of the error. Current abnormality screen is displayed.

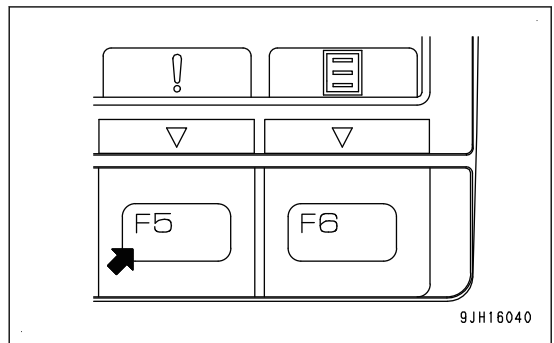

9JH16040

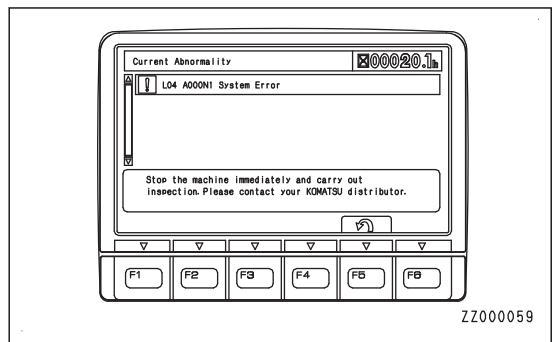

ZZ000059

## WARNING DISPLAY

### NOTICE

When any of action levels “L01” to “L04” is displayed on the machine monitor, there is abnormality in the machine.

Take appropriate actions following the list of action level displays and remedies.

The caution lamp that lights up in red when an action level is displayed warns operator to stop the machine urgently, stop or pause the current operation.

If no action is taken, the machine can be seriously affected. Take necessary actions immediately.

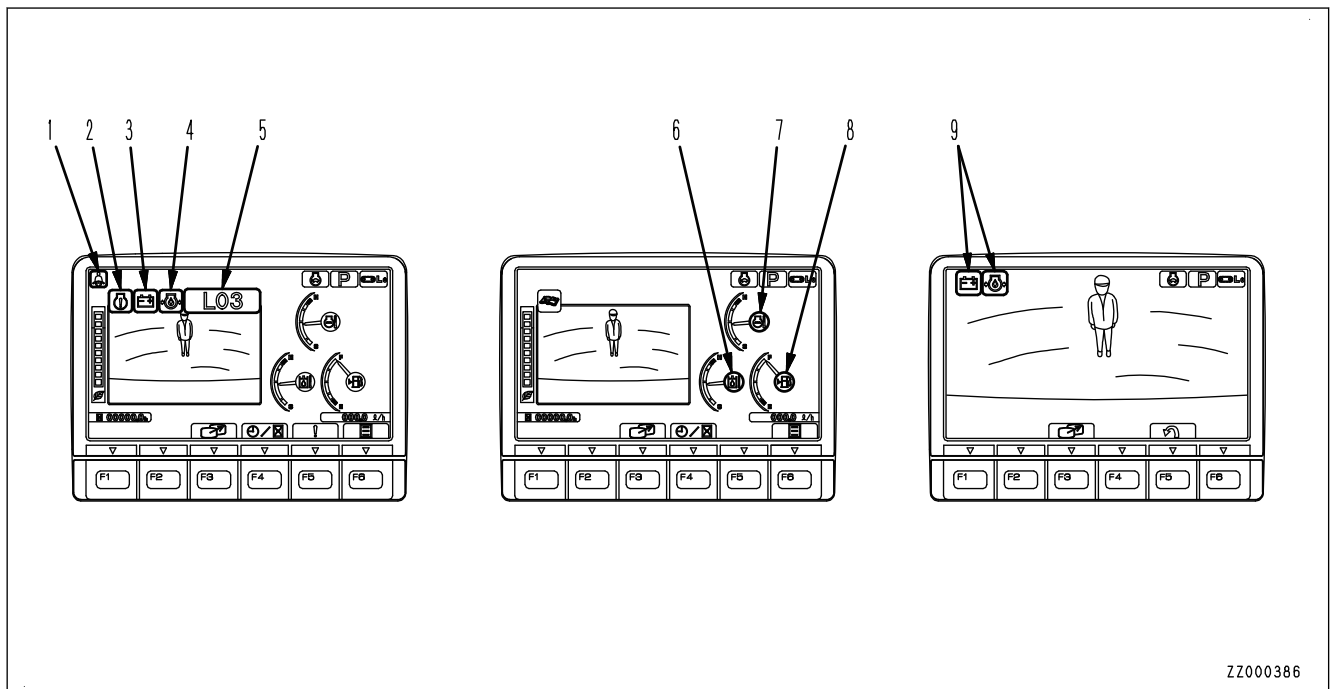

(1) Seat belt caution lamp

(2) Caution lamp

(3) Caution lamp

(4) Caution lamp

(5) Action level display

(6) Hydraulic oil temperature caution lamp

(7) Engine coolant temperature caution lamp

(8) Fuel level caution lamp

(9) Caution lamp

### Standard screen (camera display and meter display)

When 1 type of caution is generated, it is displayed on caution lamp (2).

When 2 types of caution are generated, they are displayed on caution lamps (2) and (3).

When 3 types of caution are generated, they are displayed on caution lamps (2), (3), and (4).

When 4 types or more of caution are generated, they are displayed on caution lamps (2), (3), and (4) alternately at intervals of 2 seconds.

### Whole camera image display screen

The current cautions are indicated by flashing of caution lamp (9).

When 2 or more cautions are generated, they are sequentially displayed starting from the leftmost side of the screen.

ZZ000386



## When displaying only meter

On the standard screen (camera display, meter display), press switch F3, and only the meter is displayed.  
For detail, see "CAMERA IMAGE SELECTOR SWITCH".

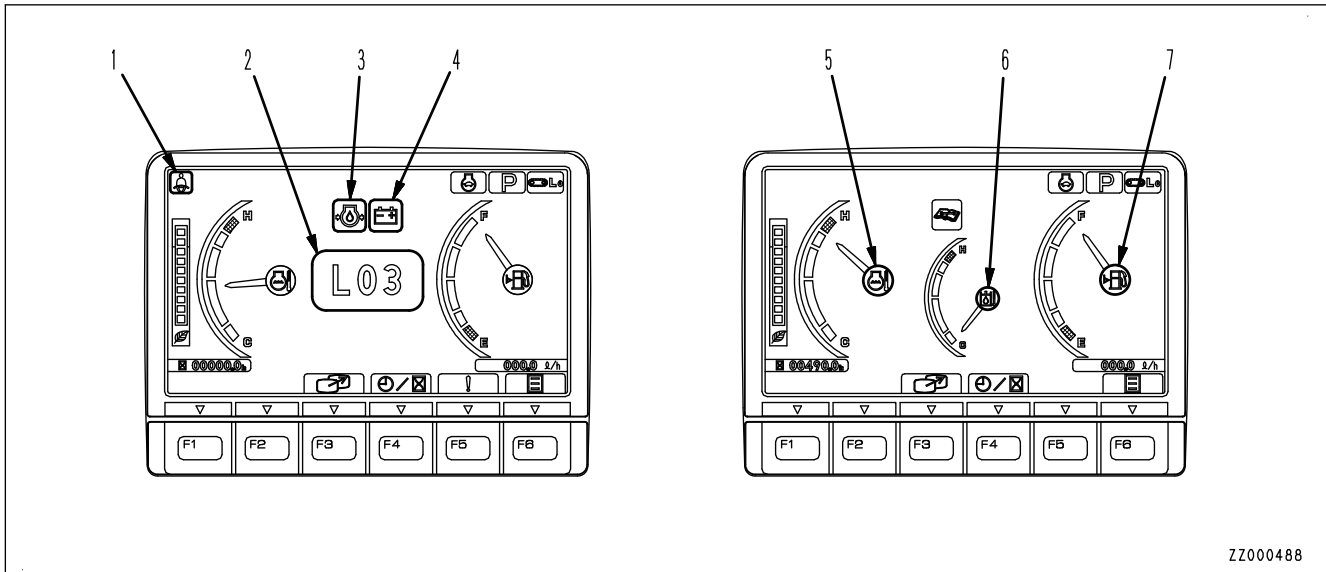

- (1) Seat belt caution lamp
- (2) Action level display
- (3) Caution lamp
- (4) Caution lamp

- (5) Engine coolant temperature caution lamp
- (6) Hydraulic oil temperature caution lamp
- (7) Fuel level caution lamp

### Standard screen (only meter display)

When 1 type of caution is generated, it is displayed on caution lamp (3).

When 2 types of caution are generated, they are displayed on caution lamps (3) and (4).

When 3 types or more of caution are generated, they are displayed on caution lamps (3) and (4) alternately at intervals of 2 seconds.

### ACTION LEVEL DISPLAY

Action level display indicates the degree of urgency of the abnormality currently generated on the machine by “L01” to “L04”.

The larger the number in the table is, the more serious effects the abnormality may have on the machine if it is left with no action.

If the machine monitor indicates an action level, check the message displayed on the monitor.

When switch F5 is pressed on the standard screen while the action level is displayed, the list of the current abnormality are displayed.

When the machine monitor displays an action level, take appropriate actions according to “List of action level displays and required actions”.

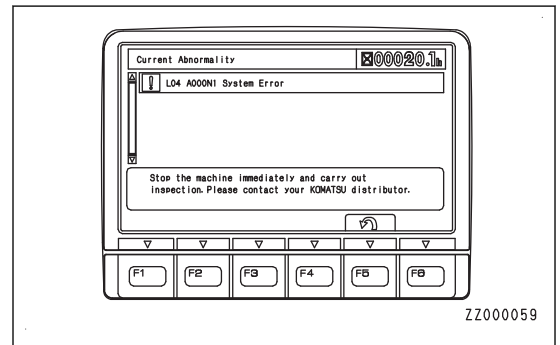
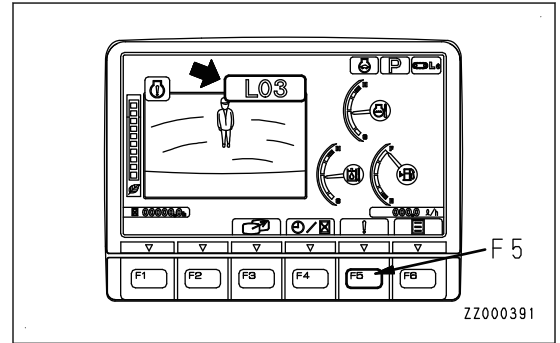

#### List of action levels and required actions









Degree of urgency	Action level	Buzzer	Color of caution lamp	Required action
High ↑       ↓ Low	L04	Sounds continuously	Lights up in red	Stop the machine immediately and ask your Komatsu distributor for inspection and maintenance.
	L03	Sounds intermittently	Lights up in red	Stop the work, move the machine to a safe place, and then ask your Komatsu distributor for inspection and maintenance.
	L02	Sounds intermittently	Lights up in red	Stop the work and run the engine at medium speed with no load or stop it.  If the condition is not improved, ask your Komatsu distributor for inspection and maintenance.
	L01	Does not sound	Lights up in yellow	Some functions may be restricted from use, but the machine can operate.  When you finish the operation, always have the inspection and maintenance performed.  Ask your Komatsu distributor for the inspection and maintenance as needed.



## CAUTION LAMP LIST

### NOTICE

- These caution lamps do not guarantee the condition of the machine.  
Do not simply rely on the caution lamp when performing checks before starting (start-up inspection). Always get off the machine and check each item directly.
- When the caution lamp is displayed in red, if no action is taken, the machine can be seriously affected.  
Take the remedy immediately.
- The engine output or engine speed is limited and the machine operation speed may become slow, depending on the contents of the alarm.

### Caution lamps and display colors

Symbol	Type of caution lamp	Display color/Machine condition (action level)			
		Red	Yellow	White	Blue
 9JC01159	Engine coolant temperature caution lamp	High temperature (L02)	-	Low temperature	Normal
 9JC01160	Hydraulic oil temperature caution lamp	High temperature (L02)	-	Low temperature	Normal
 9JC01161	Fuel level caution lamp	Low level	-	-	Normal
 9JC01169	System state caution lamp	Abnormal (L04/L03)	Abnormal (L01)	-	-
 9JC01171	Hydraulic system caution lamp	Abnormal (L04/L03)	Abnormal (L01)	-	-
 9JC01170	Engine system caution lamp	Abnormal (L04/L03)	Abnormal (L01)	-	-
 ZZ000283	Auto-idle stop sudden stop caution lamp	Abnormal (L03)	Abnormal (L01)	-	-
 9JC01164	Engine oil pressure caution lamp	Low oil pressure (L03)	-	-	-
 9JC01163	Charge level caution lamp	Abnormal (L03)	-	-	-

Symbol	Type of caution lamp	Display color/Machine condition (action level)			
		Red	Yellow	White	Blue
 9JC01175	Air conditioner system caution lamp	-	Abnormal (L01)	-	-
 9JC01168	Maintenance time caution lamp	Due time is over	Notice	-	-
 ZZ000489	Seat belt caution lamp	Seat belt is not fastened	-	-	-

For the meaning of each caution lamp and the remedy to take for it, see the section of each caution lamp.

### CURRENT ABNORMALITY DISPLAY SWITCH

If there is any abnormality currently generated, “!” is displayed on top of switch F5.

While “!” is displayed, press switch F5 to shift the monitor display screen to “Current Abnormality” screen.

Take appropriate remedies according to the message displayed on the monitor.

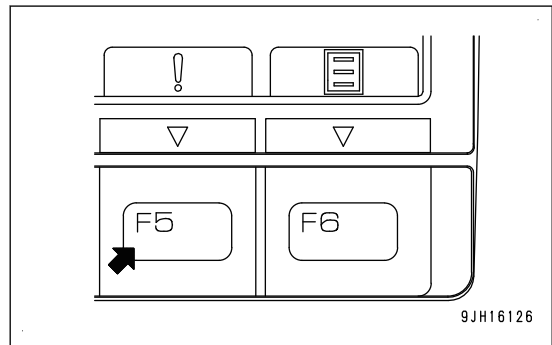
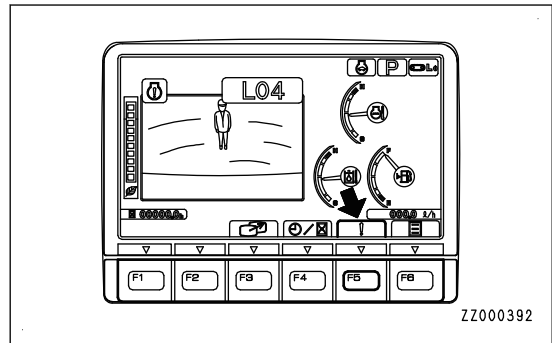

### Operation on “Current Abnormality” screen

On “Current Abnormality” screen, you can perform the following operations with switches F1, F2 and F5.

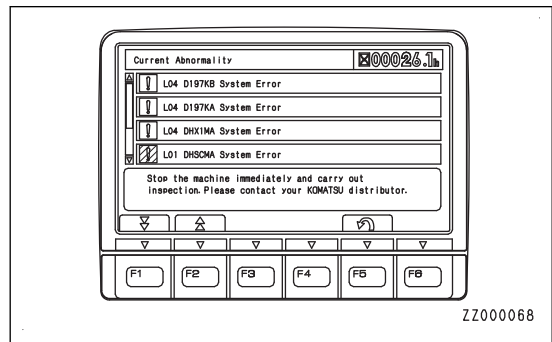

F1: Displays next page. When on the last page, it displays the first page.

F2: Displays the previous page. When on the first page, it displays the last page.

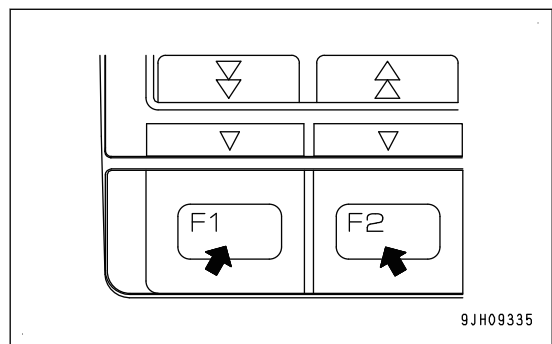

F5: Returns the screen to the standard screen.

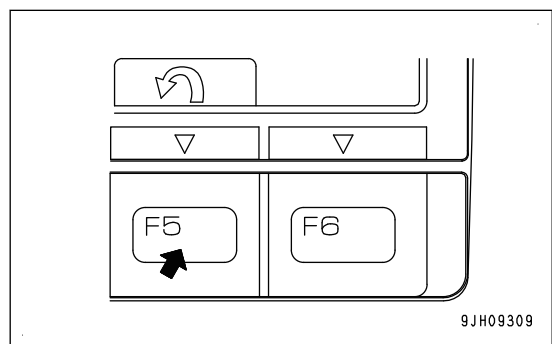

## ENGINE COOLANT TEMPERATURE CAUTION LAMP

Engine coolant temperature caution lamp warns about states caused by engine coolant temperature.

### When abnormal

The caution lamp lights up in red and action level "L02" is displayed.

The engine coolant temperature is abnormally high.

While this lamp is lit, the overheat prevention system is automatically actuated and the engine speed drops.

Stop operations and run it at low idle until the caution lamp changes to the normal display color (lights up in blue) at the correct temperature.

### When temperature is low

The caution lamp lights up in white.

The engine coolant temperature is low.

The engine needs to be warmed up.

Perform the warm-up operation for the engine until the caution lamp changes to the normal display color (lights up in blue) at the correct temperature.

For detail, see "METHOD FOR ENGINE WARM-UP OPERATION".

### When temperature is correct

The caution lamp lights up in blue.

## HYDRAULIC OIL TEMPERATURE CAUTION LAMP

The hydraulic oil temperature caution lamp warns about states of hydraulic oil temperature.

### When abnormal

The caution lamp lights up in red and action level "L02" is displayed.

The hydraulic oil temperature is abnormally high.

Stop operations and stop the engine or run it at low idle until the caution lamp changes to the normal display color (lights up in blue) at the correct temperature.

### When temperature is low

The caution lamp lights up in white.

The hydraulic oil temperature is low.

It is necessary to warm up the hydraulic component.

Perform the warm-up operation for the hydraulic component until the caution lamp changes to the normal display color (lights up in blue) at the correct temperature.

For detail, see "METHOD FOR HYDRAULIC SYSTEM WARM-UP OPERATION".

### When temperature is correct

The caution lamp lights up in blue.

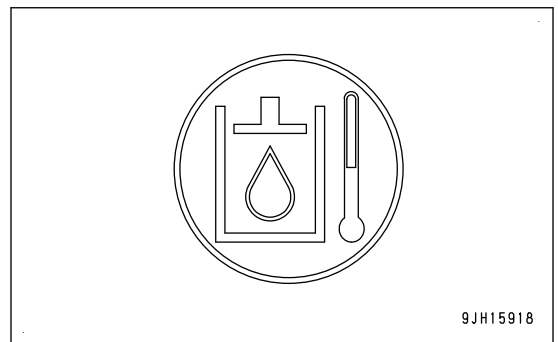
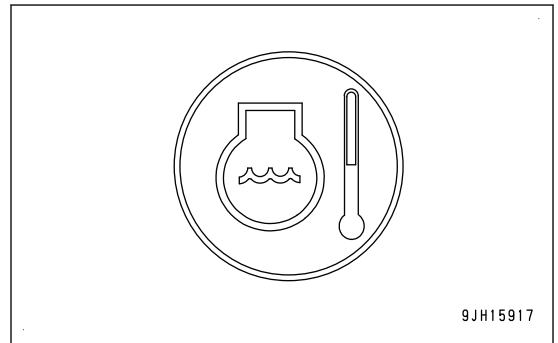

## FUEL LEVEL CAUTION LAMP

The fuel level caution lamp warns about low remaining fuel level.

### When fuel level is low

The caution lamp lights up in red.

The remaining fuel amount is approximately 32 ℓ (8.45 U.S.Gal) or less.

Add fuel as soon as possible.

### When normal

The caution lamp lights up in blue.

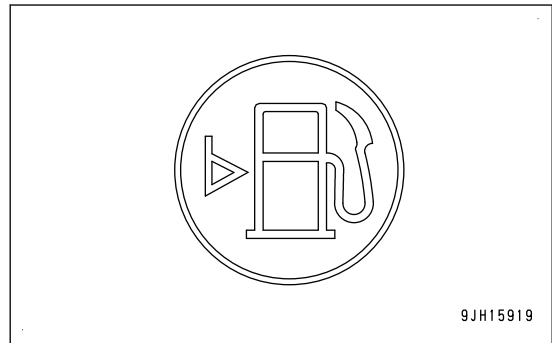

## SYSTEM CAUTION LAMP

The system caution lamp warns about abnormality in the machine system, including the sensors.

### When action level “L04” is displayed

The caution lamp lights up in red and the alarm buzzer sounds continuously.

Stop the machine immediately and ask your Komatsu distributor for inspection and maintenance.

### When action level “L03” is displayed

The caution lamp lights up in red and the alarm buzzer sounds intermittently.

Stop the operation and move the machine to a safe place, then ask your Komatsu distributor for inspection and maintenance.

### When action level “L01” is displayed

The caution lamp lights up in yellow.

Some functions may be restricted for use, but the machine can operate.

When you finish the operation, always perform the inspection and maintenance.

Ask your Komatsu distributor for inspection and maintenance as needed.

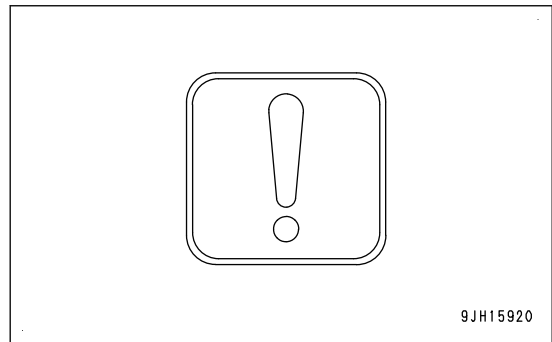

## HYDRAULIC SYSTEM CAUTION LAMP

The hydraulic system caution lamp warns about abnormality in the hydraulic system.

### When action level “L04” is displayed

The caution lamp lights up in red and the alarm buzzer sounds continuously.

Stop the machine immediately and ask your Komatsu distributor for inspection and maintenance.

### When action level “L03” is displayed

The caution lamp lights up in red and the alarm buzzer sounds intermittently.

Stop the operation and move the machine to a safe place, then ask your Komatsu distributor for inspection and maintenance.

### When action level “L01” is displayed

The caution lamp lights up in yellow.

Some functions may be restricted for use, but the machine can operate.

When you finish the operation, always perform the inspection and maintenance.

Ask your Komatsu distributor for inspection and maintenance as needed.

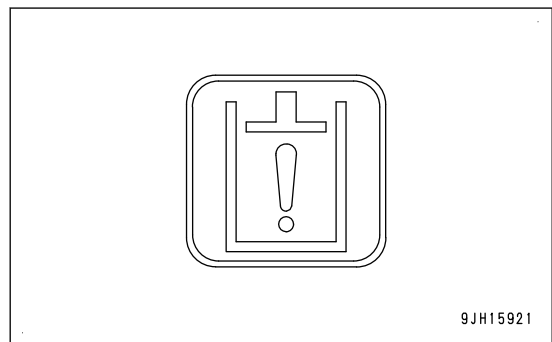

## ENGINE SYSTEM CAUTION LAMP

### CAUTION

Continuous operation with the red caution lamp being lit may affect the machine seriously. Stop the engine immediately.

The engine system caution lamp warns about abnormality in the engine system.

#### When action level “L04” is displayed

The caution lamp lights up in red and the alarm buzzer sounds continuously.

Stop the machine immediately and ask your Komatsu distributor for inspection and maintenance.

#### When action level “L03” is displayed

The caution lamp lights up in red and the alarm buzzer sounds intermittently.

Stop the operation and move the machine to a safe place, then ask your Komatsu distributor for inspection and maintenance.

#### When action level “L01” is displayed

The caution lamp lights up in yellow.

Some functions may be restricted for use, but the machine can operate.

When you finish the operation, always perform the inspection and maintenance.

Ask your Komatsu distributor for inspection and maintenance as needed.

## ENGINE SUDDEN STOP BY AUTO IDLE STOP CAUTION LAMP

The auto idle stop sudden stop caution lamp warns about the abnormality when the engine is stopped abruptly by the auto idle stop function for more than the specific times.

#### When action level “L03” is displayed

The caution lamp lights up in red and the alarm buzzer sounds intermittently.

Stop the operation and move the machine to a safe place, then ask your Komatsu distributor for inspection and maintenance.

#### When action level “L01” is displayed

The caution lamp lights up in yellow.

The engine durability may be lower but the machine can operate.

When you finish the operation, always perform the inspection and maintenance.

Ask your Komatsu distributor for inspection and maintenance as needed.

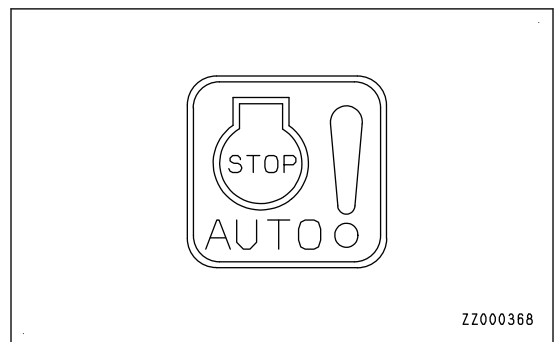
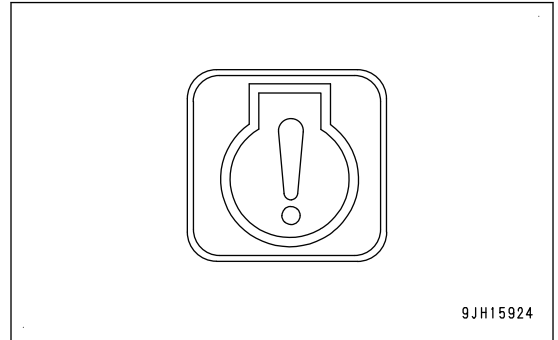



**ENGINE OIL PRESSURE CAUTION LAMP**

Engine oil pressure caution lamp warns about abnormality of engine lubricating oil pressure.

**When oil pressure is low**

The caution lamp lights up in red and indicates action level "L03".

The alarm buzzer sounds intermittently.

Stop the operation and move the machine to a safe place, then ask your Komatsu distributor for inspection and maintenance.

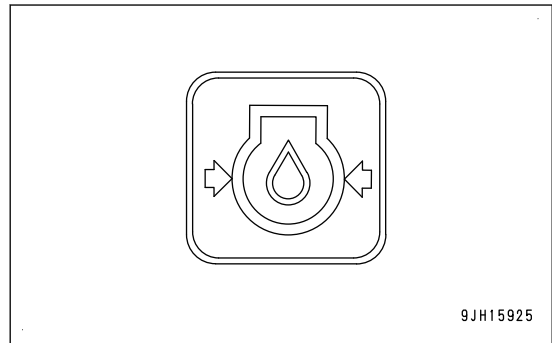

**CHARGE LEVEL CAUTION LAMP**

Charge level caution lamp warns about abnormality in the charging system while the engine is running.

**When abnormal**

The caution lamp lights up in red and indicates action level "L03".

The alarm buzzer sounds intermittently.

Charging is not be performed normally while the engine is running.

Stop the engine and check the fan belt for damage, and then ask your Komatsu distributor for inspection and maintenance.

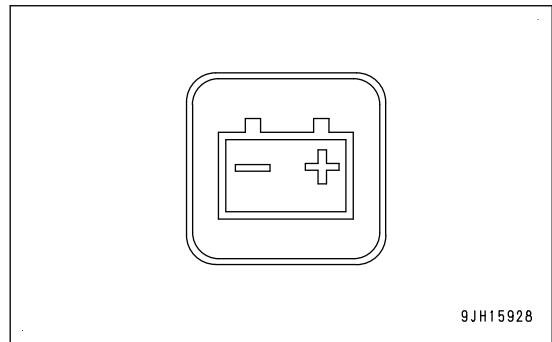

**AIR CONDITIONER SYSTEM CAUTION LAMP**

Air conditioner system caution lamp warns about abnormality in air conditioner system.

**When abnormal**

The caution lamp lights up in yellow and indicates action level "L01".

The air conditioner system has abnormality.

Ask your Komatsu distributor for inspection and maintenance as soon as possible.

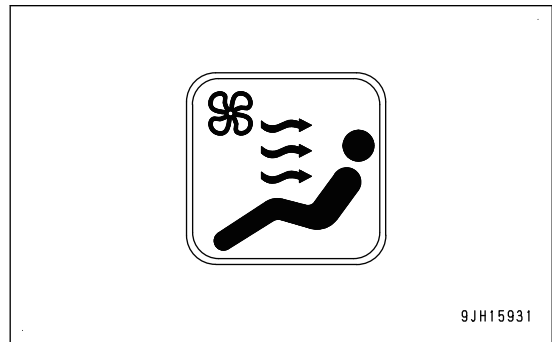

**MAINTENANCE TIME CAUTION LAMP**

Maintenance time caution lamp displays notices and alarms concerning maintenance time.

This lamp lights up when the starting switch is turned to "ON" position. It goes out after 30 seconds and the display changes to the standard screen.

**When the due time is over**

The caution lamp lights up in red.

The maintenance due time is over.

If no action is taken, the machine performance will become worse and the machine life will be shortened.

Perform necessary maintenance as soon as possible.

**When giving the notice of the due time**

The warning lamp lights up in yellow.

The maintenance due time is approaching.

Prepare necessary parts for the maintenance.

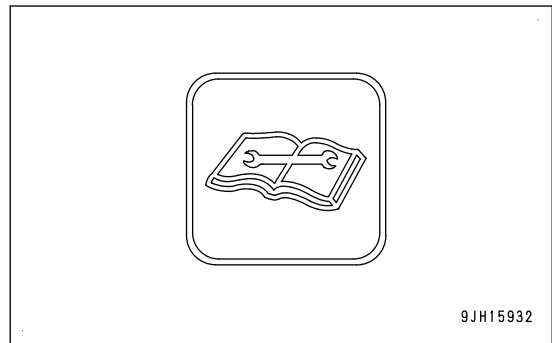

**REMARK**

- Check maintenance items on “Maintenance” tab screen by pressing switch F6 on the maintenance time warning screen shown in the right drawing or on the standard screen.
- The lighting time of maintenance due time notice (yellow) has been initially set to 30 hours, but it can be changed. To change the setting, ask your Komatsu distributor.
- For operations on “Maintenance” tab screen, see “MAINTENANCE SCREEN SETTING”.

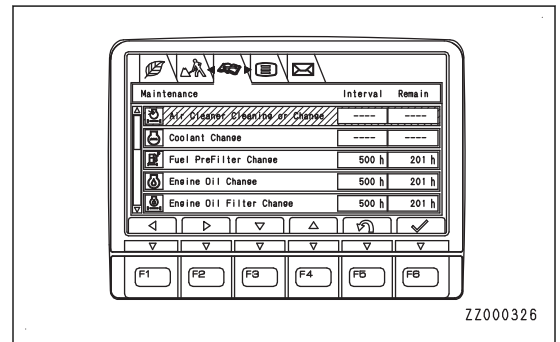
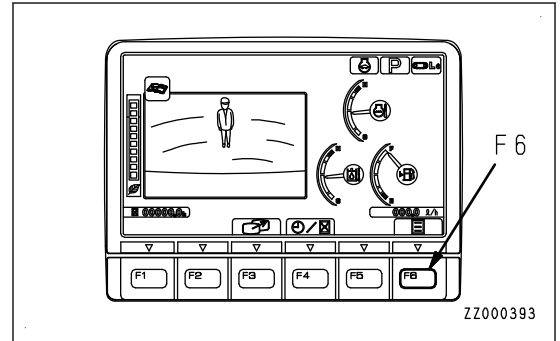

**SEATBELT CAUTION LAMP**

The seat belt caution lamp lights up when the seat belt is not fastened. It goes out when the seat belt is fastened.

For fastening the seat belt, see “METHOD FOR FASTENING AND UNFASTENING SEAT BELT”.



**PILOT DISPLAY AND METER DISPLAY**

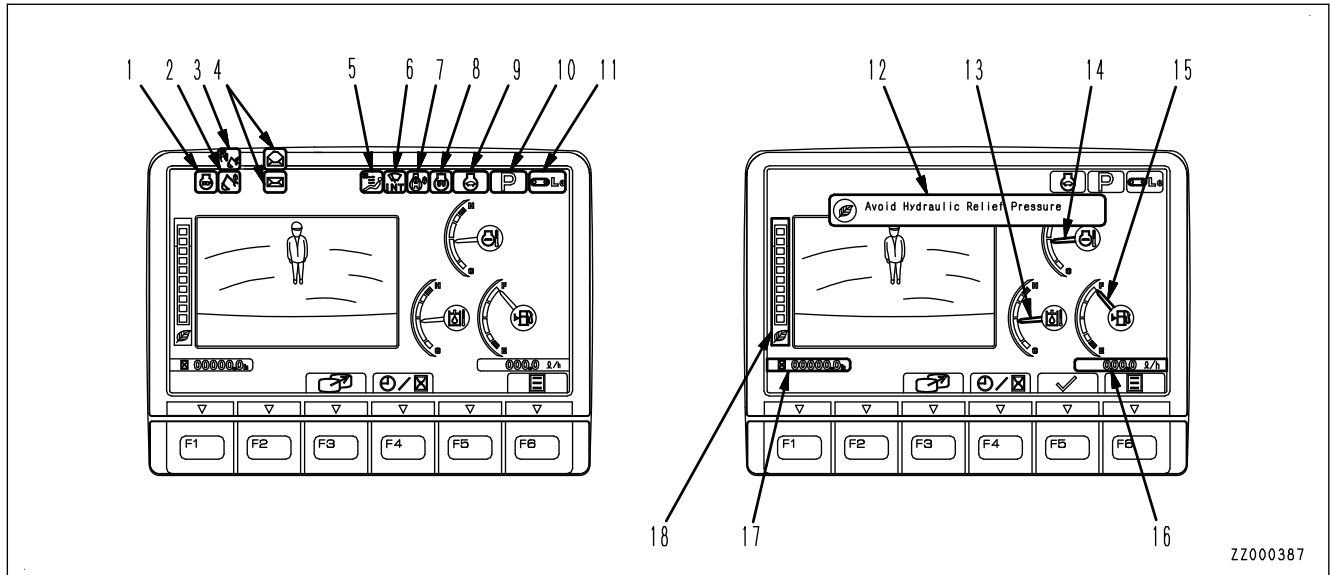

ZZ000387

**Pilot display**

- (1) Engine stop pilot lamp
- (2) Work equipment lock pilot lamp
- (3) Lock lever automatic lock release pilot lamp
- (4) Message display
- (5) Air conditioner pilot lamp
- (6) Wiper pilot lamp
- (7) Swing lock pilot lamp
- (8) Preheating pilot lamp
- (9) Auto-deceleration pilot lamp
- (10) Working mode display
- (11) Travel speed display
- (12) ECO guidance

**Meter display**

- (13) Hydraulic oil temperature gauge
- (14) Engine coolant temperature gauge
- (15) Fuel gauge
- (16) Fuel consumption gauge
- (17) Service meter/ clock
- (18) ECO gauge

**When displaying only meter**

On the standard screen (camera display, meter display), press switch F3, and only the meter is displayed. For detail, see “CAMERA IMAGE SELECTOR SWITCH”.

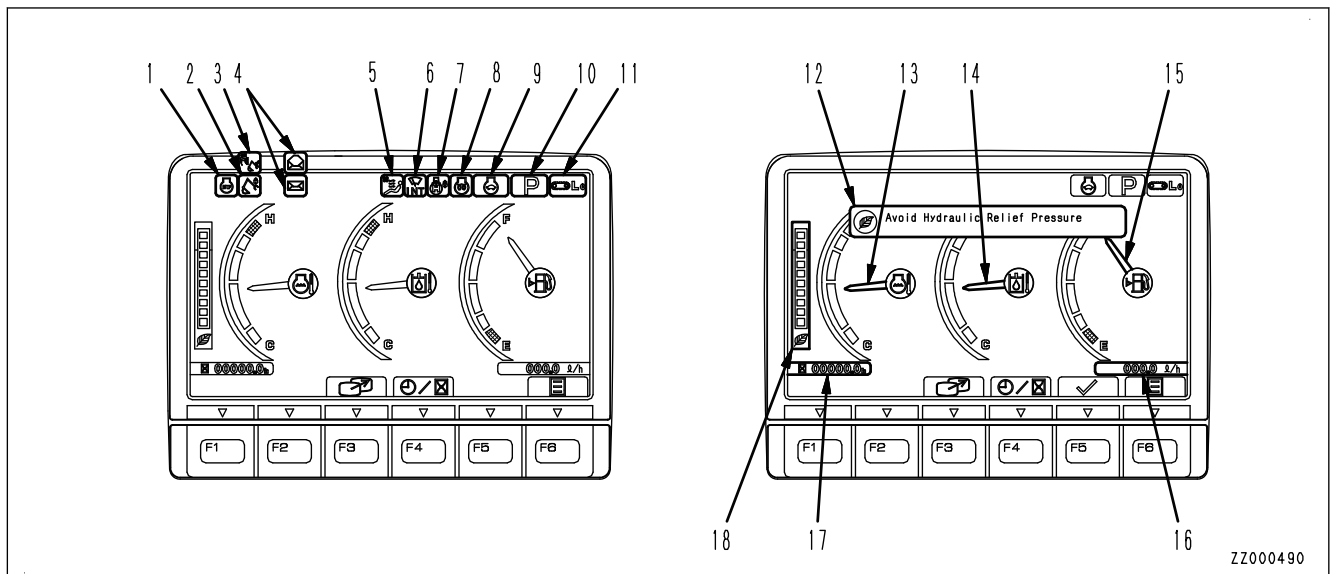

ZZ000490

**Pilot display**

- (1) Engine stop pilot lamp
- (2) Work equipment lock pilot lamp
- (3) Lock lever automatic lock release pilot lamp
- (4) Message display
- (5) Air conditioner pilot lamp
- (6) Wiper pilot lamp
- Meter display
- (13) Engine coolant temperature gauge
- (14) Hydraulic oil temperature gauge
- (15) Fuel gauge

- (7) Swing lock pilot lamp
- (8) Preheating pilot lamp
- (9) Auto-deceleration pilot lamp
- (10) Working mode display
- (11) Travel speed display
- (12) ECO guidance
- (16) Fuel consumption gauge
- (17) Service meter/ clock
- (18) ECO gauge

**PILOT DISPLAY**

The pilot display at the top of the screen consists of the pilot lamps to check the actuation of each function. When the starting switch is turned ON, the pilot lamps light up when the displayed items are functioning.

**PREHEATING PILOT LAMP**

The preheating pilot lamp is displayed while the engine is preheated before started at temperature below 0 °C {32 °F} .

When the temperature is low (in cold weather) and the automatic preheating function operates, the preheating pilot lamp lights up. When the preheating is completed, it goes out.

Automatic preheating is for a maximum of approximately 30 seconds.

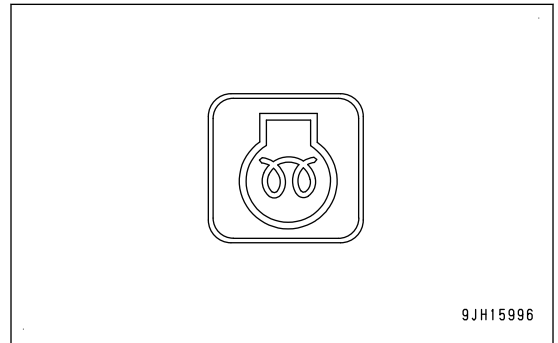

**WIPER PILOT LAMP**

The wiper pilot lamp shows the operating state of the windshield wiper.

The operation of the wiper switch is indicated by the pilot lamp as follows.

- When ON lights up: Windshield wiper operates continuously
- When INT lights up: Windshield wiper operates intermittently
- OFF: Windshield wiper stops

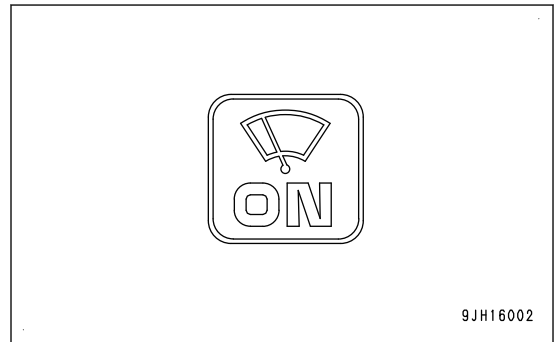

**SWING LOCK PILOT LAMP**

The swing lock pilot lamp shows the state of the swing parking brake cancel switch.

The pilot lamp display when the swing parking brake cancel switch is operated is as follows.

- Pilot lamp flashes: Swing parking brake cancel switch ON
- Pilot lamp goes out: Swing parking brake cancel switch OFF

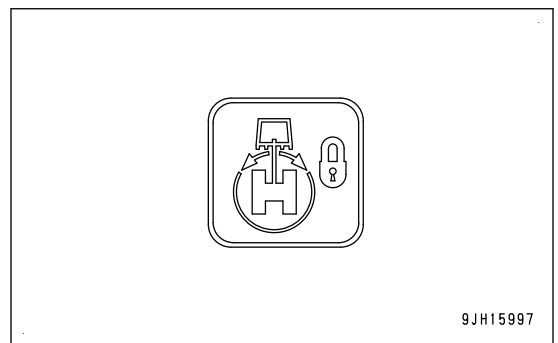

### AUTO-DECELERATION PILOT LAMP

The auto-deceleration pilot lamp shows the setting of the auto-deceleration either ON or OFF.

The pilot lamp display when the auto-deceleration switch is operated is as follows.

Pilot lamp lights up: Auto-deceleration ON

Pilot lamp goes out: Auto-deceleration OFF

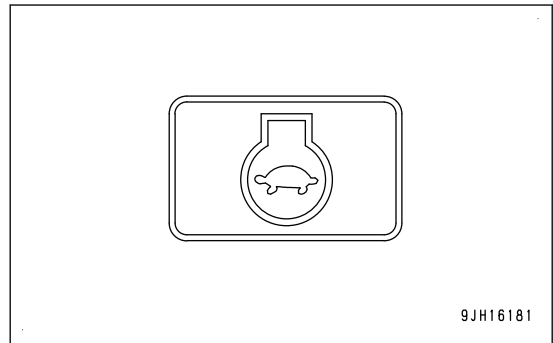

### WORKING MODE DISPLAY

The working mode display shows the setting of the working mode.

The working mode set with the working mode switch is shown as follows.

“P”: P mode (for heavy-duty operations)

“E”: E mode (for operations with emphasis on fuel consumption)

“L”: L mode (for fine control operations)

“B”: B mode ( for breaker operations) (For machines ready for installation of attachments)

“ATT/P”: ATT/P mode (for operations of 2-way attachments like crusher, etc.)

“ATT/E”: ATT/E mode (for operations of 2-way attachments like crusher in emphasis of fuel consumption)



### TRAVEL SPEED DISPLAY

The travel speed display shows the set mode of the travel speed.

The travel speed is indicated as follows according to the setting of the travel speed selector switch.

“Lo”: Low-speed travel

“Hi”: High-speed travel

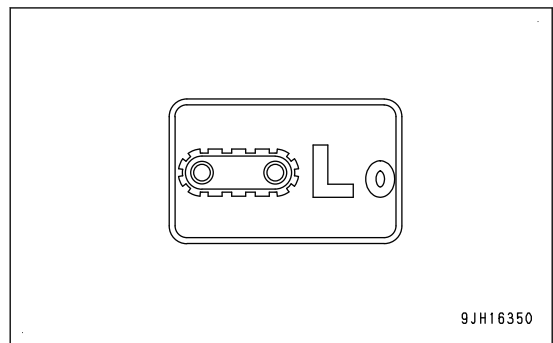

### AIR CONDITIONER PILOT LAMP

The air conditioner pilot lamp shows the operating state of the air conditioner.

Pilot lamp lights up: Air conditioner ON

Pilot lamp goes out: Air conditioner OFF

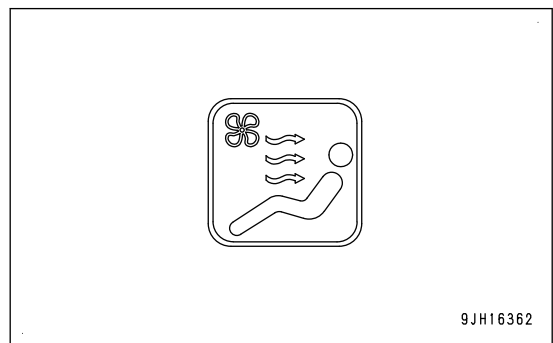

## MESSAGE DISPLAY

The message display lights up when there is a message from Komatsu.

To read the message, see "MESSAGE DISPLAY".

Lights up in green (A): There is unread message.

Lights up in blue (B): There is any read message to which no reply is made.

OFF: No messages

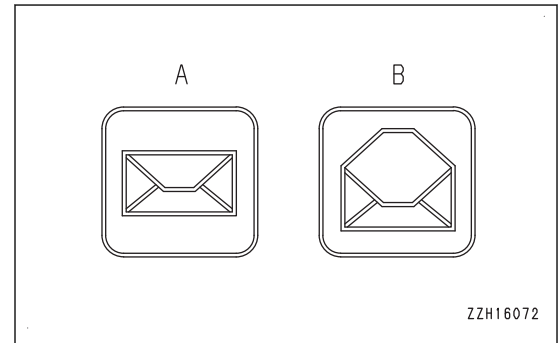

## ENGINE STOP PILOT LAMP

The engine stop pilot lamp is displayed while the engine is stopped. It goes out when the engine is started.

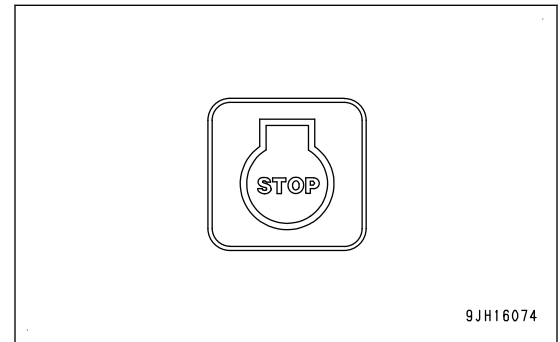

## WORK EQUIPMENT LOCK PILOT LAMP

The work equipment lock pilot lamp lights up when the work equipment is locked.

It lights up when the work equipment is switched from the unlock mode to the lock mode.

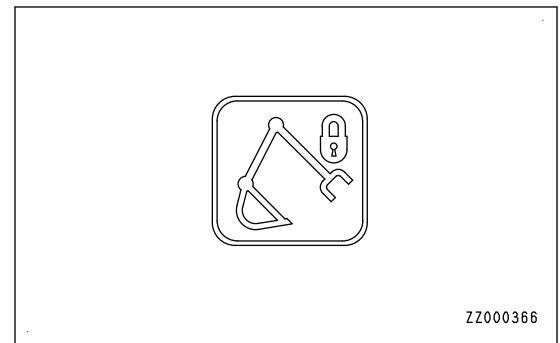

## LOCK LEVER AUTOMATIC LOCK CANCEL PILOT LAMP

The lock lever automatic lock cancel pilot lamp shows the state of the lock lever automatic lock cancel switch.

The pilot lamp display when the lock lever automatic lock cancel switch is operated is as follows.

Pilot lamp flashes: Lock lever automatic lock cancel switch ON

Pilot lamp goes out: Lock lever automatic lock cancel switch OFF

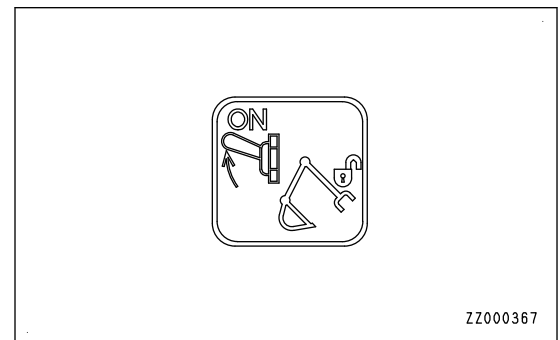

### ECO GUIDANCE

The guidance for energy saving operation to reduce the fuel consumption may be displayed during operation.

The details of the guidance are as follows:

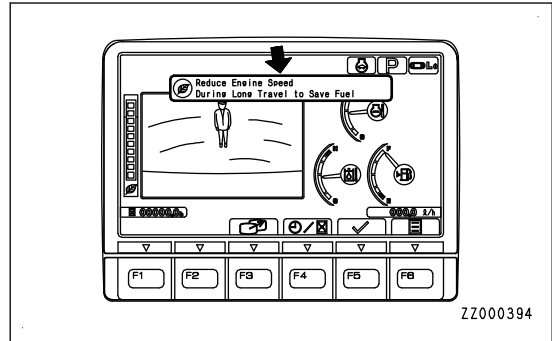

### Idling Stop Guidance

If no operation is performed for more than 5 minutes, and the engine is idling, the idling stop message is displayed on the monitor. When waiting for work or taking short break, stop the engine to reduce unnecessary fuel consumption.

The idling stop message goes out if any lever is operated again or switch F5 is pressed.

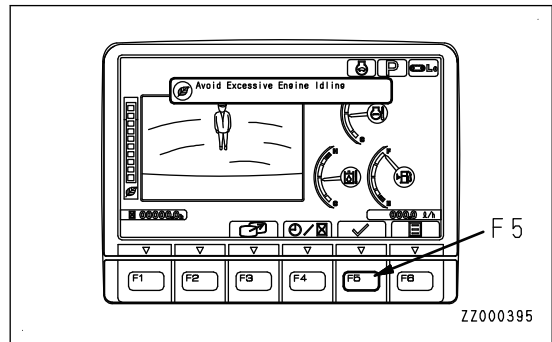

### Guidance To Avoid Hydraulic Relief

If the hydraulic oil is kept relieved for more than 3 seconds during operation, the hydraulic relief deterrence message is displayed on the monitor.

The hydraulic relief deterrence message goes out 10 seconds later or when switch F5 is pressed.

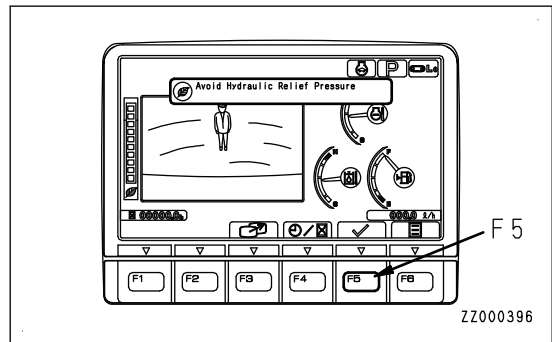

### E Mode Recommendation Guidance

If light-load work is continued for more than 10 minutes in P or ATT/P mode, E mode recommendation message is displayed. When working on light load, set the working mode to E to reduce unnecessary fuel consumption.

E mode recommendation message goes out more than 10 seconds after or when switch F5 is pressed.

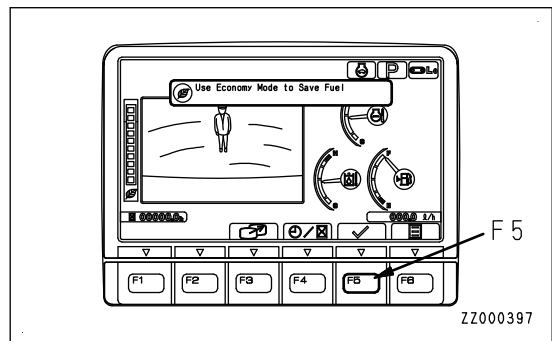

### Reduce Travel Speed (Recommended) Guidance

If the machine keeps traveling for more than 2 minutes with the travel mode “Hi” and the fuel control dial at the High idle (MAX) position, the travel partial mode recommendation message is displayed. When traveling for a long time, the fuel consumption can be reduced by lowering the fuel control dial.

The travel partial mode recommendation message goes out more than 10 seconds after or when switch F5 is pressed.

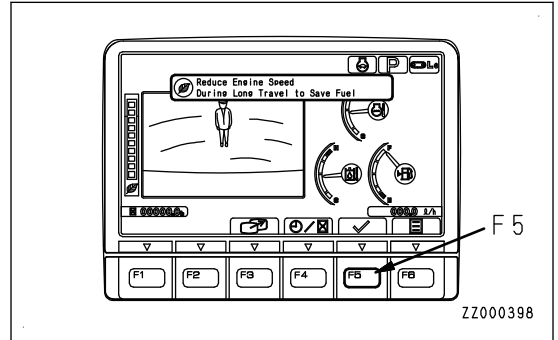

### Low Fuel Level Guidance

If the operable time estimated from the current fuel level and the latest average fuel consumption is shorter than 8 hours, the low fuel level message is displayed.

The low fuel level message goes out more than 10 seconds after or when switch F5 is pressed.

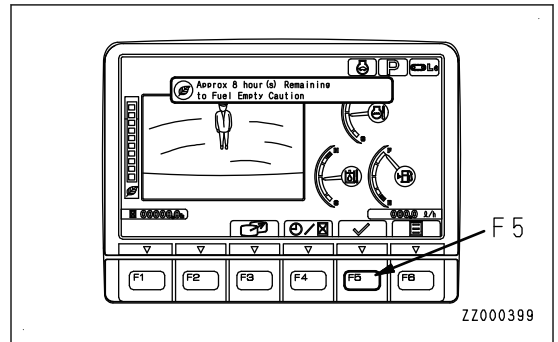



**METER DISPLAY**

**ENGINE COOLANT TEMPERATURE GAUGE**

Engine coolant temperature gauge shows the engine coolant temperature.

If the indicator is in green range during operations, it is normal. When the indicator goes beyond (A) of red range during operations, the overheat prevention system is actuated.

- (A) to (B): Red range
- (A) to (C): Green range
- (C) to (D): White range

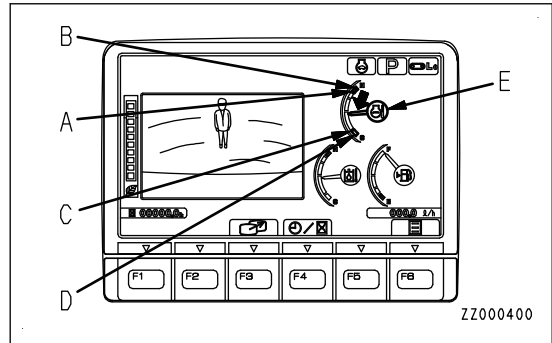

The overheat prevention system is actuated as follows.

Red range (A) position: Engine coolant temperature caution lamp (E) shows abnormality display.

Red range (B) position: Engine speed changes to low idle, engine coolant temperature caution lamp (E) shows abnormality display and alarm buzzer sounds at the same time

The overheat prevention system continues to operate until the pointer enters the green range.

When the engine is started, if the indicator is at position (D), engine coolant temperature caution lamp (E) shows the low-temperature display.

In this case, perform warm-up operation.

Display (G) when temperature is low: Caution lamp background (K) is white.

Display (H) when temperature is correct: Caution lamp background (K) is blue.

Display (J) when condition is abnormal: Caution lamp background (K) is red.

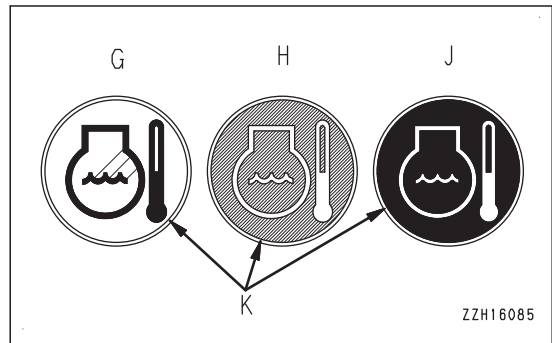

### HYDRAULIC OIL TEMPERATURE GAUGE

Hydraulic oil temperature gauge shows the hydraulic oil temperature.

If the indicator is in green range during operations, it is normal.

When the indicator nears the red range (A) during operation, the hydraulic oil temperature has exceeded 102 °C {215.6 °F}. Then run the engine at low idle or stop it and wait for the hydraulic oil temperature to drop.

- (A) to (B): Red range
- (A) to (C): Green range
- (C) to (D): White range

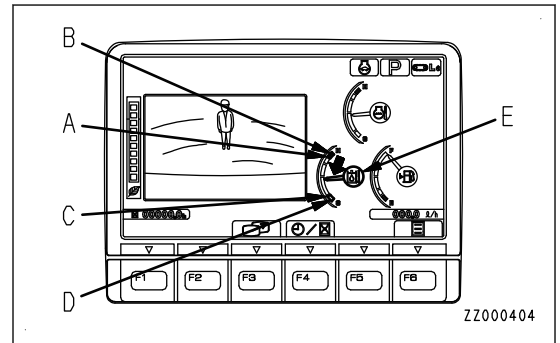

**REMARK**

When the indicator reaches red range (A), the hydraulic oil temperature is as follows.

Red range (A) position: 102 °C {215.6 °F} or more

Red range (B) position: 105 °C {221 °F} or more

When the indicator is in red range (A) to (B), hydraulic oil temperature caution lamp (E) indicates abnormality. When the engine is started, if the indicator is at position (C), the hydraulic oil temperature is below 20 °C {68 °F} and hydraulic oil temperature caution lamp (E) indicates low temperature. In this case, perform warm-up operation. For details, see “METHOD FOR HYDRAULIC SYSTEM WARM-UP OPERATION”.

Display (G) when temperature is low: Caution lamp background (K) is white.

Display (H) when temperature is correct: Caution lamp background (K) is blue.

Display (J) when condition is abnormal: Caution lamp background (K) is red.

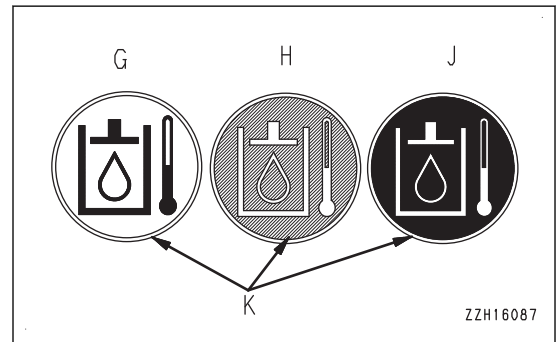

### FUEL GAUGE

Fuel gauge shows the amount of fuel in the fuel tank.

The indicator should be in the green range during operations.

If the indicator starts to enter red range (A) during operation, the remaining fuel is 32 ℓ {8.45 U.S.Gal} or less, so perform inspection and add fuel.

- (A) to (B): Red range
- (A) to (C): Green range

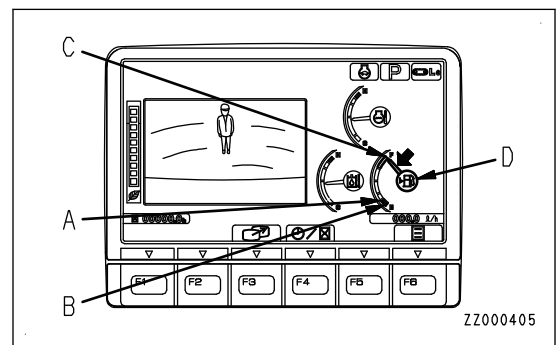

**REMARK**

When the indicator reaches red range (B), the remaining fuel is 23 ℓ {6.08 U.S.Gal} or less.

When the indicator is in red range (B), fuel level lamp (D) lights up in red.

The correct fuel level may not be displayed for a short time when the starting switch is turned to ON position, but this is not an abnormality.

**SERVICE METER / CLOCK**

The service meter/clock shows the total hours of operation of the machine or the present time.

When the engine is running, the service meter advances even when the machine is not moving. The service meter advances 0.1 every 6 operation minutes, regardless of the engine speed.

- Service meter display

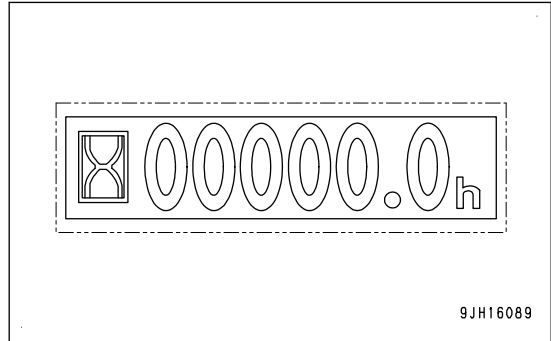

- Clock display (12-hour display)

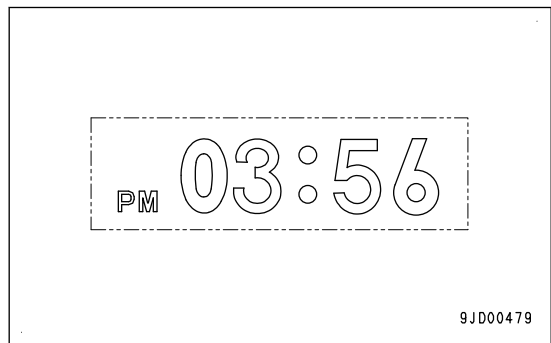

- Clock display (24-hour display)

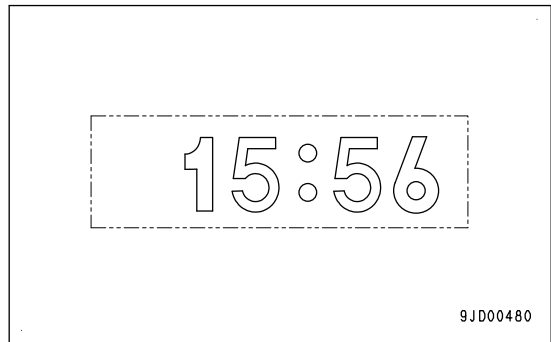

On the standard screen, when function switch F4 is pressed, it is possible to switch between the clock display and the service meter display alternately.

**REMARK**

- If the battery is disconnected for a long period for storage etc., the time information may be lost.
- Clock display (12-hour or 24-hour display is available)
- For details of setting and correction of time, see "CLOCK ADJUSTMENT".

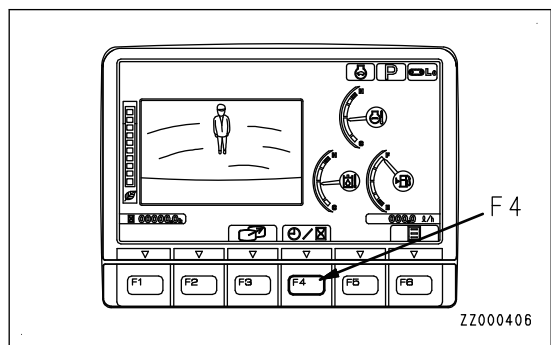

## ECO GAUGE

ECO gauge shows the instantaneous fuel consumption.

The instantaneous fuel consumption means the fuel consumption rate at each current moment, which varies with the work load and engine speed.

When the gauge is in green range A, the instantaneous fuel consumption is at a good to medium level.

When the gauge is in yellow range B, the instantaneous fuel consumption is at a bad level.

### REMARK

Although there is no abnormality on the machine when the gauge enters the yellow range, reduce the engine output to a point where there is no adverse effect on the operation for the protection of the global environment. Perform energy-saving operations in the green range. Travel less frequently. It also helps to save energy. Consider the best way of operation for saving energy.

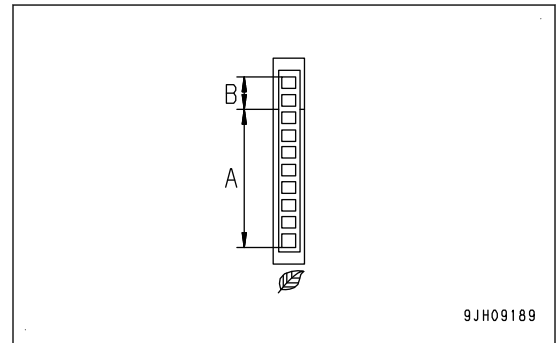

## FUEL CONSUMPTION GAUGE

Fuel consumption gauge shows the average fuel consumption of the machine.

(A): Shows the average fuel consumption of a day (from 0:00 a.m. of the day to 0:00 a.m. of the next day).

(B): Shows the split fuel consumption under measurement.

(C): Shows the split fuel consumption while measurement is stopped.

### REMARK

Display on the fuel consumption gauge can be switched between the average fuel consumption per day and the average fuel consumption during a selected period (split fuel consumption).

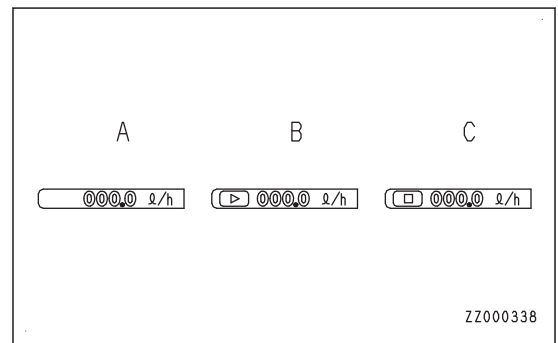

**MONITOR SWITCHES**

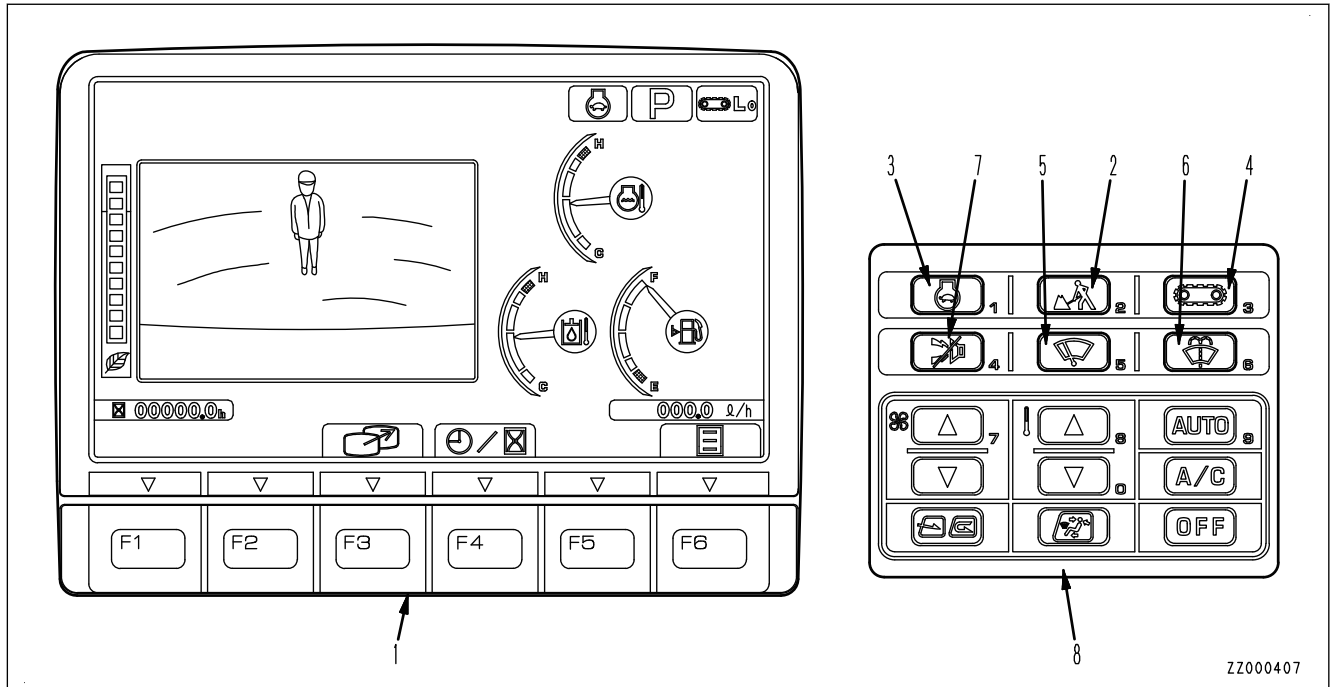

ZZ000407

- (1) Function switch
- (2) Working mode selector switch
- (3) Auto-deceleration switch
- (4) Travel speed selector switch
- (5) Wiper switch
- (6) Window washer switch
- (7) Buzzer cancel switch
- (8) Air conditioner switch

**FUNCTION SWITCHES AND GUIDANCE ICONS**

- There are 6 function switches (1) (F1 to F6) at the bottom of the monitor display. The function of each switch differs according to the content of each screen.
- The function of each function switch (1) on each screen can be confirmed by guidance icons (2) displayed above that switch.
- While guidance icon (2) is not displayed, function switch (1) does not function even if it is pressed.
- Even if guidance icon (2) is pressed, it does not function. Press function switch (1) directly under guidance icon (2) to operate the function.

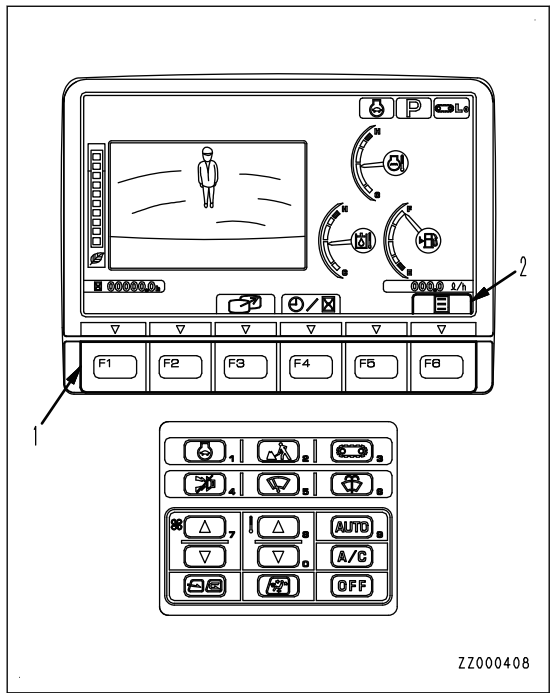

ZZ000408

When the monitor display shows the standard screen, the types of guidance icons and functions of function switches are as follows:

For the details of each function, see the detailed explanation of each item.

- (A) Switch F3: Camera image selector switch.
- (B) Switch F4: Service meter/clock display selector switch

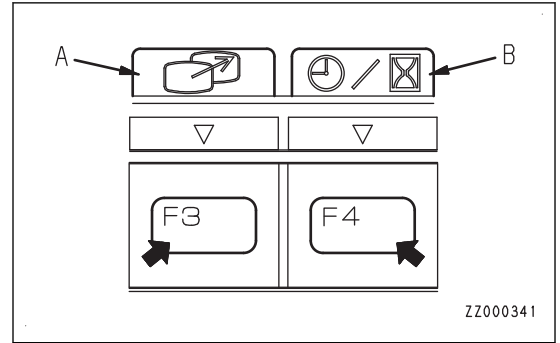

- (C) Switch F5: "Current Abnormality" display switch  
(Only while caution lamp is lit)

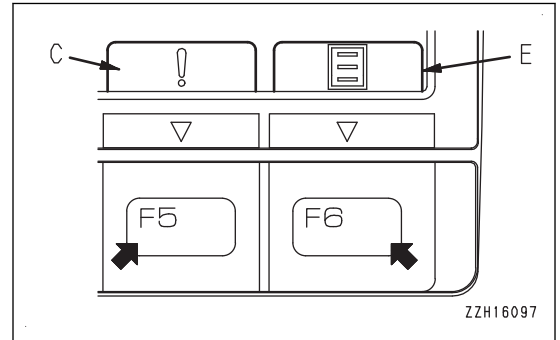

- (D) Switch F5: ECO guidance erase switch  
(While ECO guidance is displayed)
- (E) Switch F6: User menu display switch

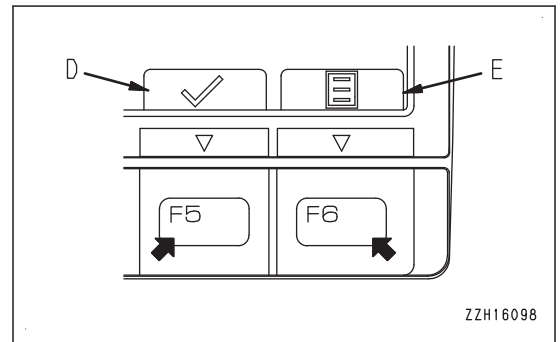

Guidance icons and their functions differ with the contents of the displayed screen, but representative guidance icons frequently used and their functions are as follows:

- (F) Switch F1 or F3: Moves to the left item. (When on the left end, it moves to the right end.)
- (G) Switch F2 or F4: Moves to the right item. (When on the right end, it moves to the left end.)

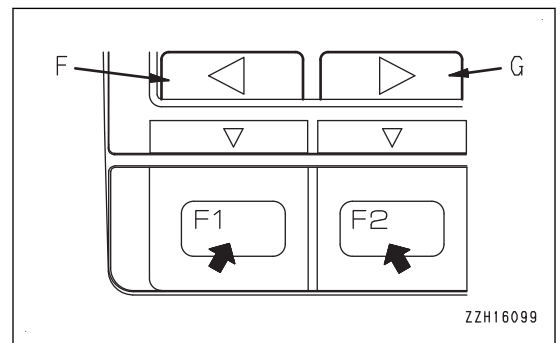

- (H) Switch F3: Moves to the item below (forward). (When on the last line, it moves to the first line.)
- (I) Switch F4: Moves to the item above (backward). (When on the first line, it moves to the last line.)

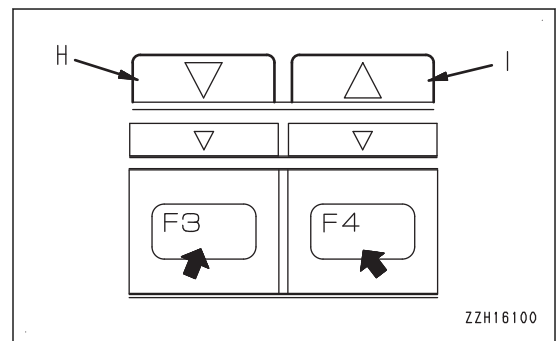

(J) Switch F5: Cancels any change and returns the screen to the previous screen.

(K) Switch F6: Enters the selection and contents to change, and proceeds the screen to the next screen.

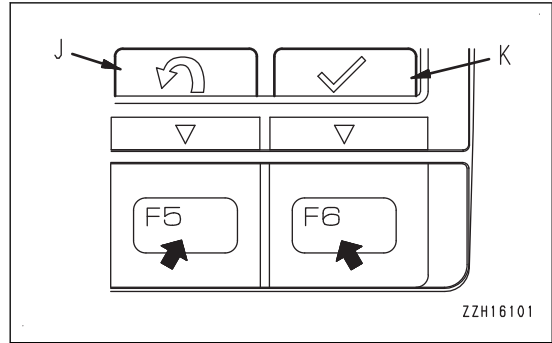

**REMARK**

- Even if some icons look the same, their display positions and corresponding function switches may differ according to the screens to be displayed.
- For the guidance icons and their functions not explained above, see the pages where the control methods of respective screens are explained.

**WORKING MODE SELECTOR SWITCH**

Use working mode selector switch to set the movement or power of the work equipment.

The operation becomes easier by selecting the mode to match the content of the operation.

P mode: For heavy-duty operations

E mode: For operations with emphasis on fuel consumption

L mode: For fine control operations

B mode: For breaker operations

ATT/P mode: For operations of 2-way attachments like crusher (machines ready for installation of attachment)

ATT/E mode: For operations emphasizing fuel consumption out of those of 2-way attachments like crusher (machines ready for installation of attachment)

- When the monitor is turned ON, it is automatically set to the mode used when the starting switch was turned to OFF position last.
- When the working mode selector switch is pressed, the Working Mode selector screen is displayed. For each set mode, "P", "E", "L", "B", "ATT/P", and "ATT/E" are displayed at the top right of the monitor display.
- For machines ready for installation of attachment, the attachment mode is added to the display.

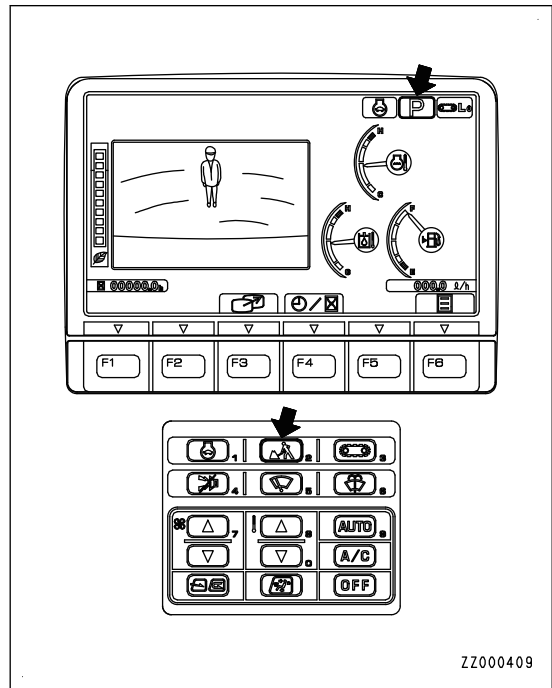

If you want to have automatic setting of P, E, L, B, ATT/P or ATT/E mode (optional default setting) when starting engine, ask your Komatsu distributor to change the setting.

**Procedure for operation**

1. When the working mode selector switch is pressed, the working mode selector screen is displayed on the monitor.
2. Press function switches F3 or F4 at the bottom of the screen or the working mode selector switch to change the mode selection one at a time.  
If no switch is touched for more than 5 seconds, the selected working mode is automatically set as the working mode and the screen changes to the one for steps 3 and 4.

**REMARK**

To return to the standard screen without changing the working mode, press function switch F5.

3. After selecting the desired mode, press function switch F6 and the mode is displayed in the center of the monitor display.  
(Example: When the power mode is selected: "P")
4. After 2 seconds, the working mode display at the top right of the screen is highlighted in yellow.
5. After 2 seconds, the screen returns to the standard screen.  
The working mode display highlighted in yellow in step 4 returns to blue.

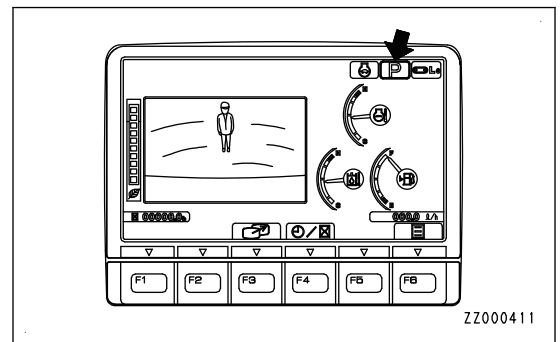
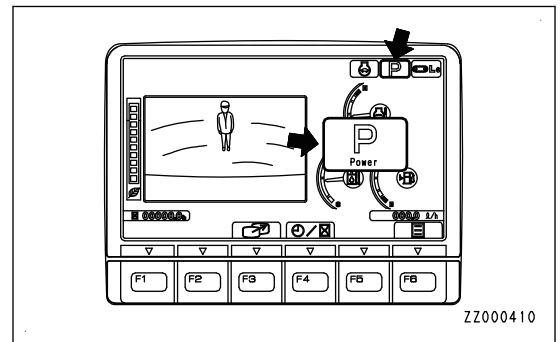
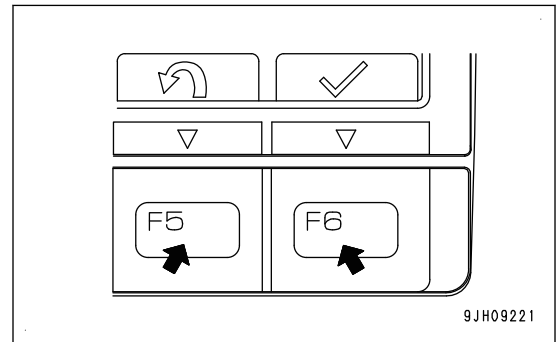
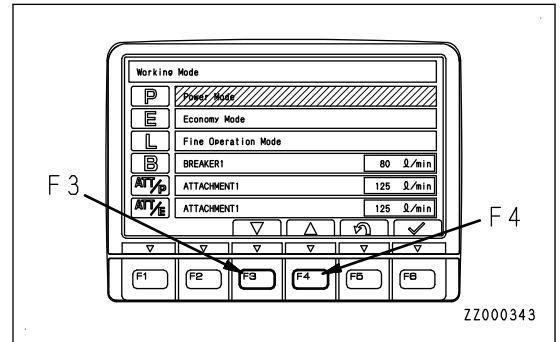



### AUTO-DECELERATION SWITCH

Auto-deceleration switch automatically lowers the engine speed and turns on the function to reduce fuel consumption when the control levers are at NEUTRAL position.

Auto-deceleration indication lamp lights up: Auto-deceleration ON

Auto-deceleration indication lamp goes off: Auto-deceleration OFF

Each time the switch is pressed, the auto-deceleration is switched between ON and OFF.

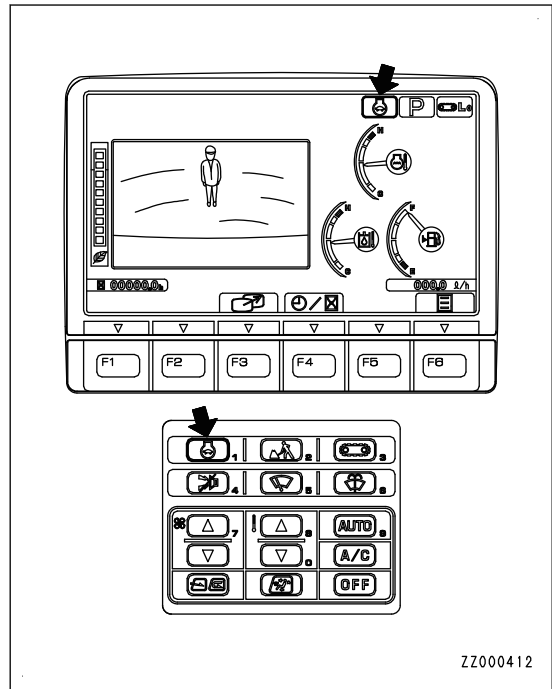

### Function of auto-deceleration

When the auto-deceleration function is ON, if the work equipment lever and travel lever are returned to NEUTRAL position, the engine speed will drop approximately after 4 seconds from the operating speed to idle speed.

As a result, fuel consumption can be reduced.

If any lever is operated in this condition, engine speed will return to the previous operating speed, and you can perform the operation.

1. When the auto-deceleration switch is pressed and the auto-deceleration function is turned ON, the mode is displayed in the center of the monitor display, and after 2 seconds, the screen returns to the standard screen.

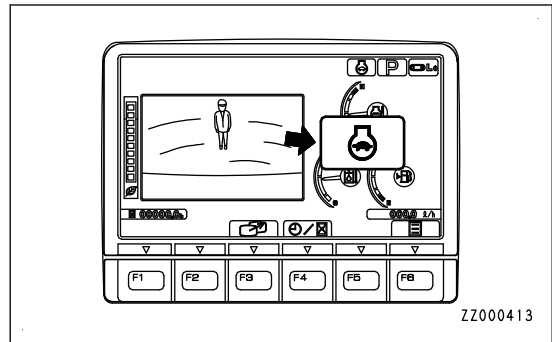

2. On the standard screen, auto-deceleration indication lamp lights up.  
(When the auto-deceleration is OFF, the indication lamp goes out.)

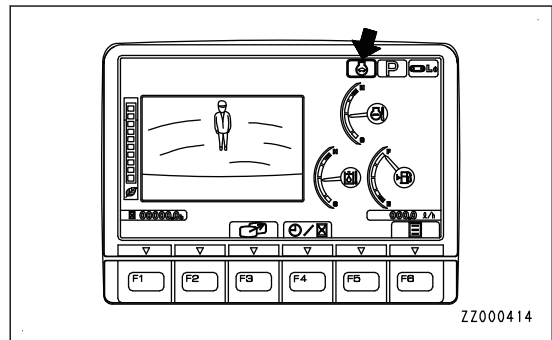

## TRAVEL SPEED SELECTOR SWITCH

### **⚠ WARNING**

- When loading to or unloading from a trailer, always drive the machine at low speed (set it to “Lo”) and never operate the travel speed selector switch during travel.
- If the travel speed is switched between “Hi” and “Lo” when the machine is traveling, the machine may deviate to one side, even when traveling in a straight line. Stop the machine before switching the travel speed.

Travel speed selector switch is used to select the travel speed from 2 stages.

“Lo” lights up: Low-speed travel

“Hi” lights up: High-speed travel

When the engine is started, the speed is automatically set to “Lo”.

Each time that the switch is pressed, the display changes “Lo” → “Hi” → “Lo” in turn.

Even if the travel speed is set to high-speed (“Hi”), when the machine travels on soft ground or uphill and travel power is needed, the system automatically shifts down to low-speed travel (“Lo”) and you do not need to operate the switch. In this case, the travel speed on the monitor display stays lit at “Hi” (high-speed).

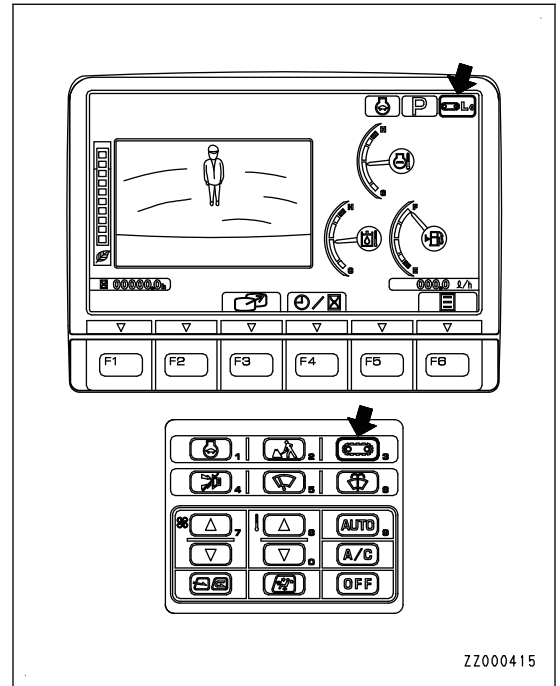

### REMARK

Each time the travel speed selector switch is switched, the mode is displayed on the monitor display, and after 2 seconds, the screen returns to the standard screen.

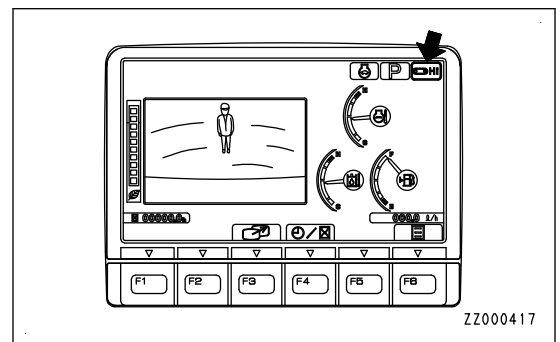
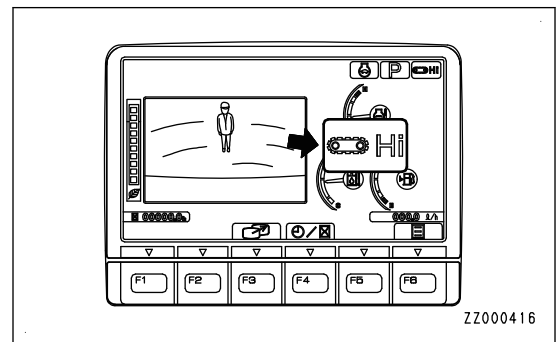

### WIPER SWITCH

- Wiper switch actuates the front window windshield wiper.
- Each time the switch is pressed, it changes “INT”→“ON”→ stop (monitor goes out).
- Windshield wiper pilot lamp “INT” lights up: Windshield wiper operates intermittently
- Windshield wiper pilot lamp “ON” lights up: Windshield wiper operates continuously
- Windshield wiper pilot lamp off: Windshield wiper stops

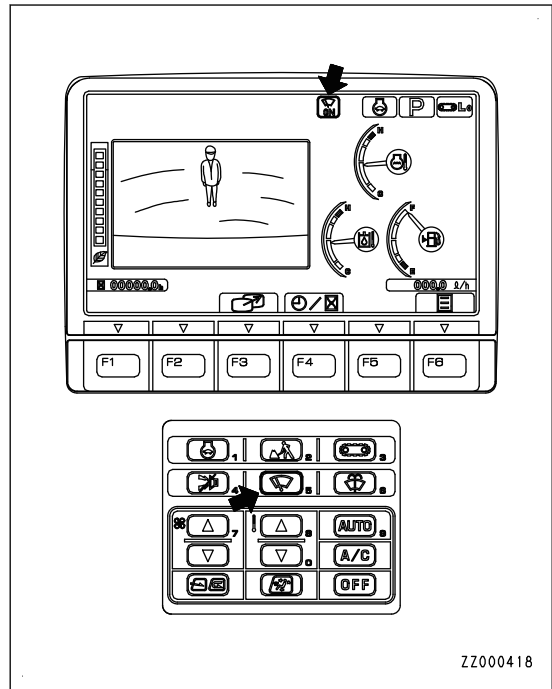

### REMARK

Each time wiper switch is pressed, the mode is displayed in the center of the monitor display, and after 2 seconds, the screen returns to the standard screen.

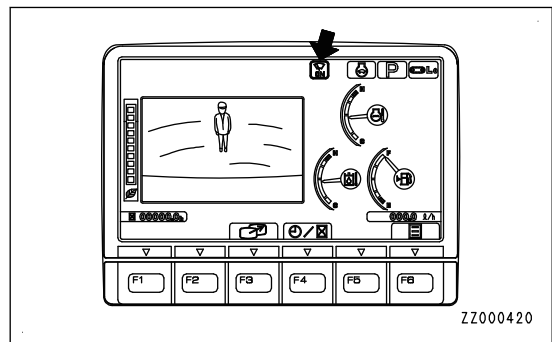
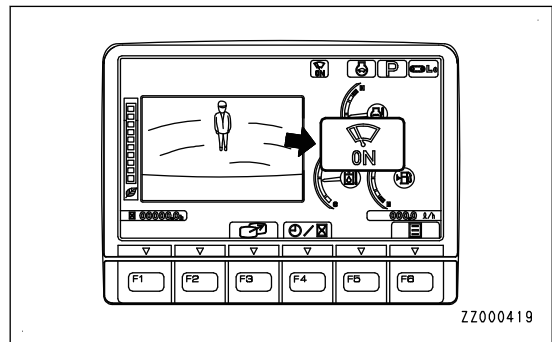

### WINDOW WASHER SWITCH

Keep pressing this switch continuously, and window washer fluid is sprayed out on the front glass. When releasing the switch, the spray stops.

- If keep pressing the switch when the wiper is stopped, the window washer fluid is sprayed out. At the same time, the wiper is actuated continuously. When releasing switch, the wiper continues to operate for 2 cycles, then stops.
- If the wiper is moving intermittently and the switch is kept pressed continuously, the window washer fluid is sprayed out. At the same time, the wiper is actuated continuously. When releasing switch, the wiper continues to operate for 2 cycles, then return to intermittent operation.

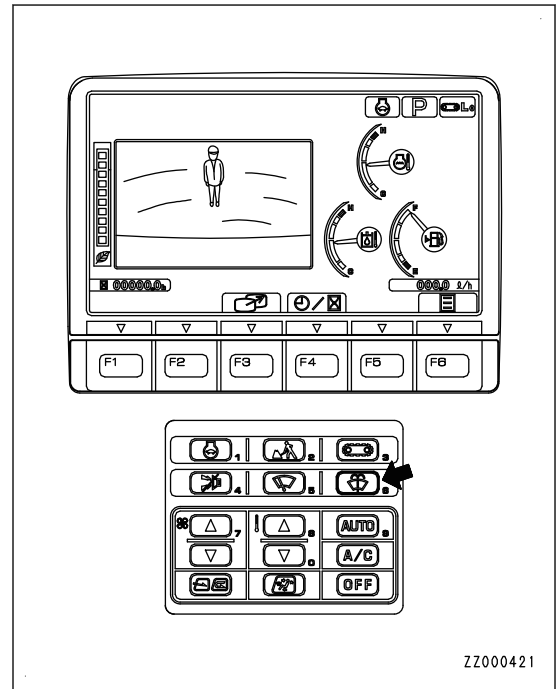

### BUZZER CANCEL SWITCH

Buzzer cancel switch is used to stop the alarm buzzer for the warning item where there is an abnormality.

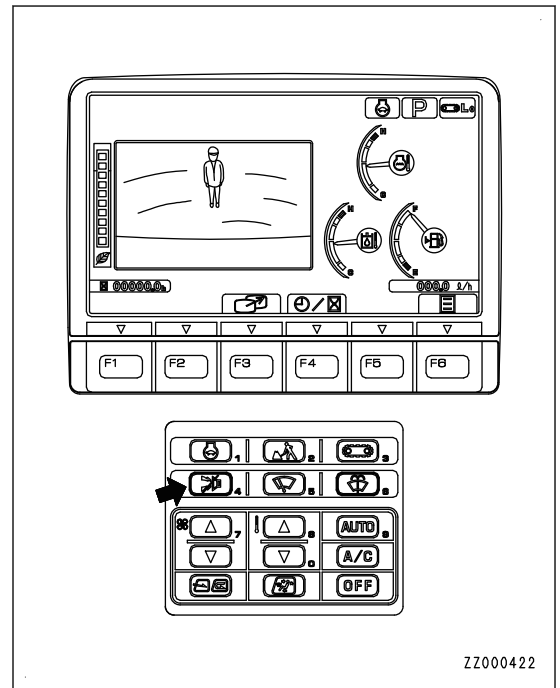

### AIR CONDITIONER SWITCH

The air conditioner switch consists of 9 switches.

For explanation of each switch, see “HANDLE AIR CONDITIONER”.

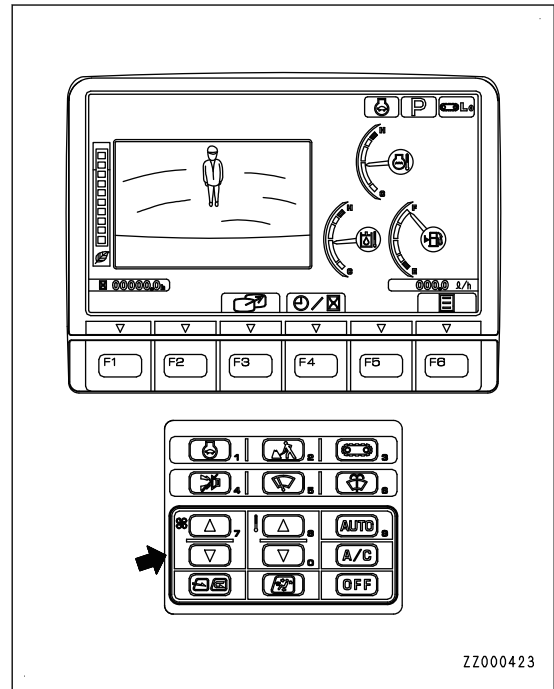

ZZ000423

### FUNCTION SWITCHES

The operation of the function switches in the standard screen

#### CAMERA IMAGE SELECTOR SWITCH

On the standard screen, you can select a display only for the camera image or a display only for the meter by pressing switch F3.

On machines not equipped with a camera, the guidance icon related to switch F3 is not displayed.

Even if switch F3 is pressed, the screen will not switch to the camera image display.

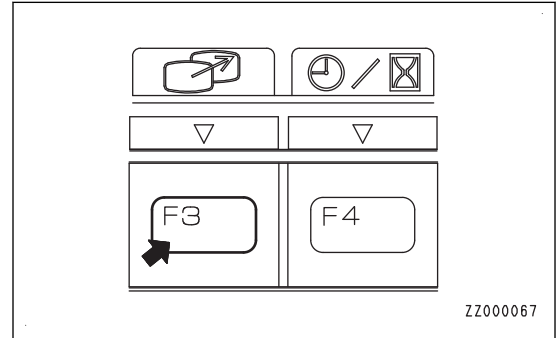

#### Operation of camera image display screen

The following is the method of changing the camera image display on the monitor.

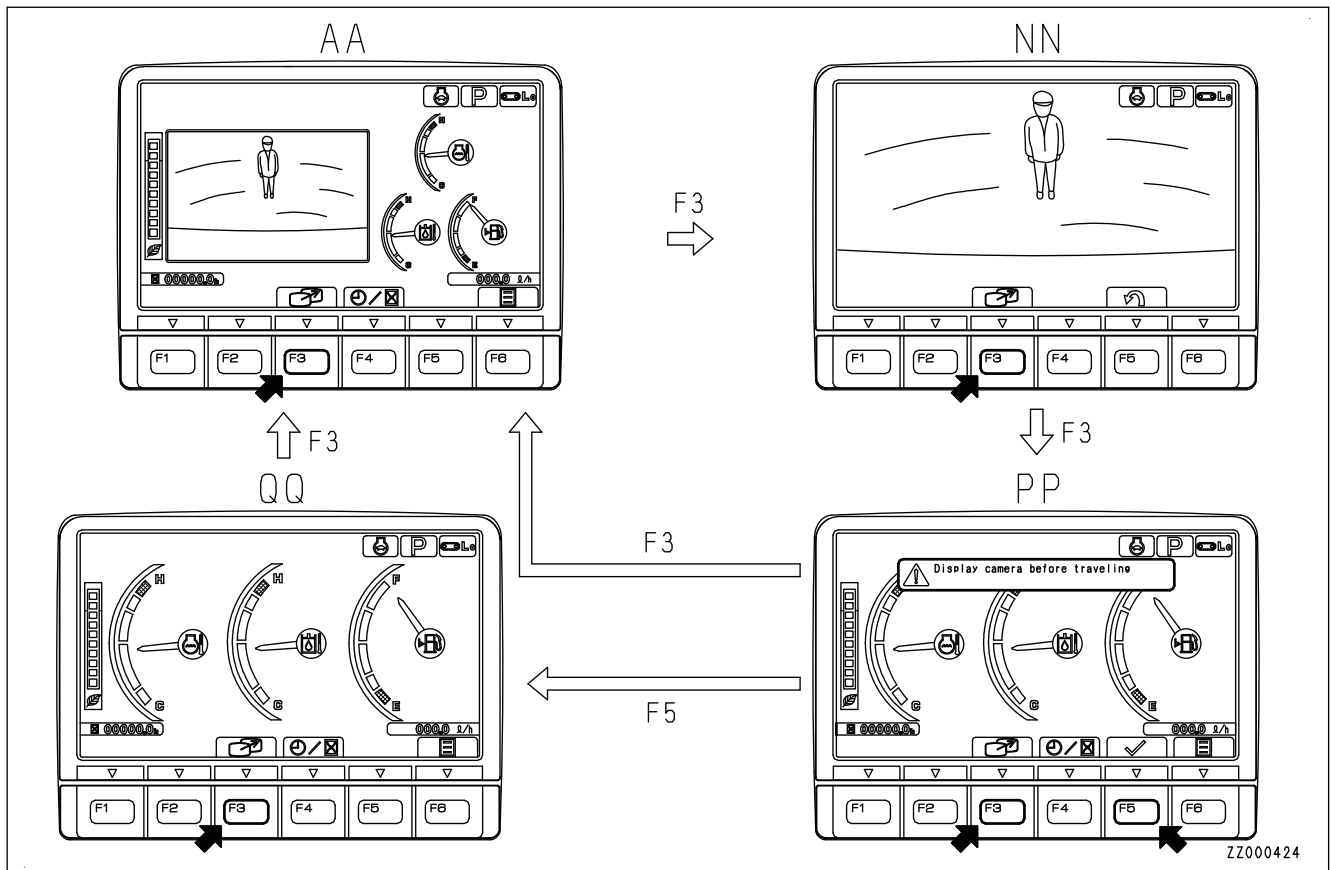

- On standard screen AA, the camera image is always displayed on the left part of the monitor.
- On standard screen AA, when switch F3 is pressed, camera image full-screen display NN is displayed. Camera image full-screen display NN is displayed on the entire screen.
- When switch F3 is pressed on camera image full-screen display NN, message screen PP is displayed and no camera image is displayed.
- On message screen PP, when switch F3 is pressed or when no switch is operated for 10 seconds, standard screen AA is displayed.
- On message screen PP, when switch F5 is pressed, the message disappears and meter display screen QQ is displayed.

For the safety, select standard screen AA or camera image display screen NN to display the camera image during travel.

**Other mode operations while displaying camera image display screen**

Even while the camera image display screen is displayed, it is possible to operate the following modes.

- The air conditioner can be operated.

When the air conditioner switch is operated, the screen switches to “A/C Setting” screen. When the screen switches to “A/C Setting” screen, press switch F6 to return to the camera image display screen. In addition, if no operation is performed for 5 seconds after the screen switches to “A/C Setting” screen, the screen automatically returns to the camera image display screen.

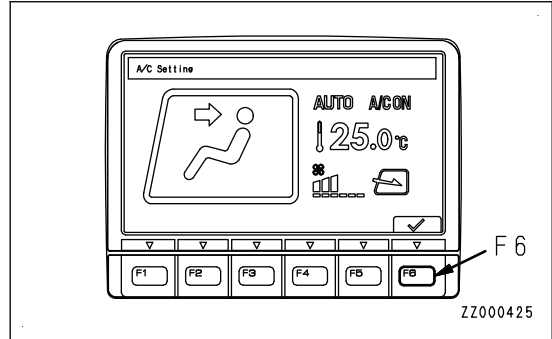

- Press the working mode selector switch to change the working mode.

When the working mode is changed, the screen returns automatically to the camera image display screen. At this time, the working mode display at the top right of the monitor screen is highlighted in yellow for 2 seconds, then returns to blue.

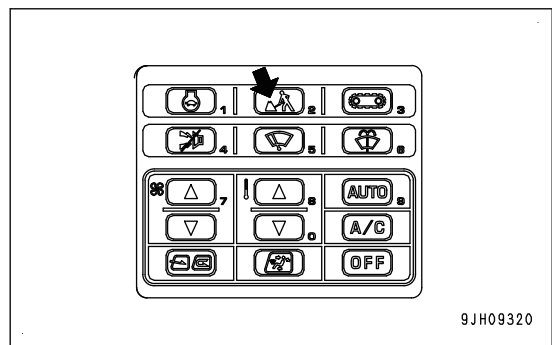

- Press the travel speed selector switch to change the travel speed.

When the travel speed is changed, the travel speed display at the top right of the monitor display is highlighted in yellow for 2 seconds, then returns to blue.

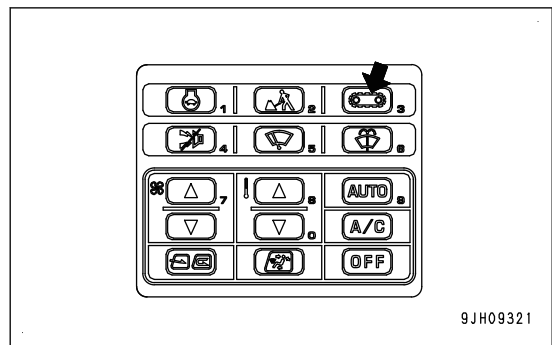

- Press the auto-deceleration switch to turn the auto-deceleration function ON/OFF.

Even if the auto-deceleration switch is pressed, the camera image display screen does not switch to another screen or return to the standard screen display.

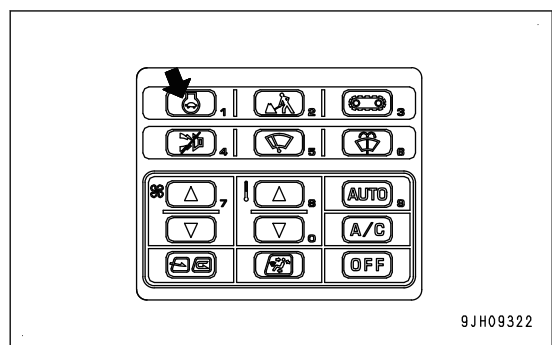

- Press the buzzer cancel switch to stop the alarm buzzer for the abnormality of warning item.

Even if the buzzer cancel switch is pressed, the camera image display screen does not switch to another screen or return to the standard screen.

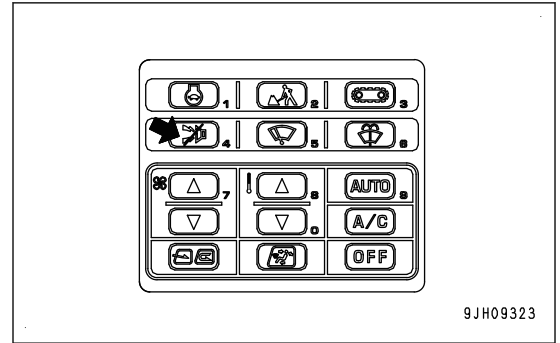

- Press the wiper switch and washer switch to operate the wipers and washer.

Even if the wiper switch or washer switch is pressed, the camera image display screen does not switch to another screen or return to the standard screen display.

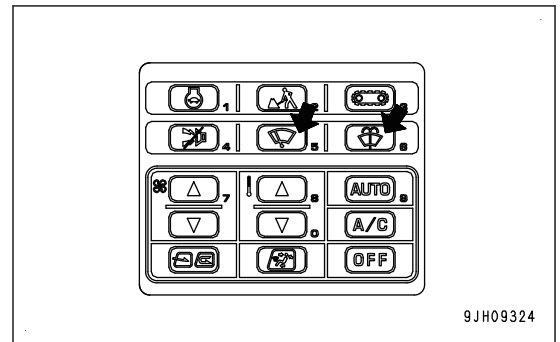

**Actions against warning during camera image display**

If a trouble occurs on the machine while the camera image display screen is being displayed, the caution lamp flashes at the top left of the screen.

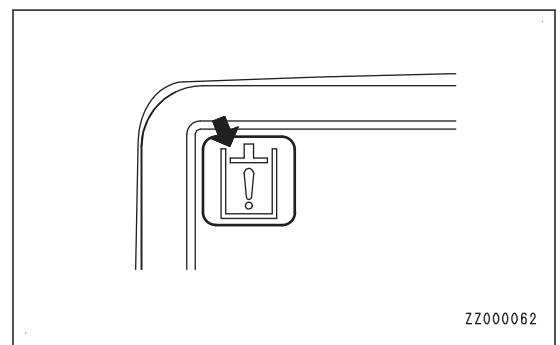
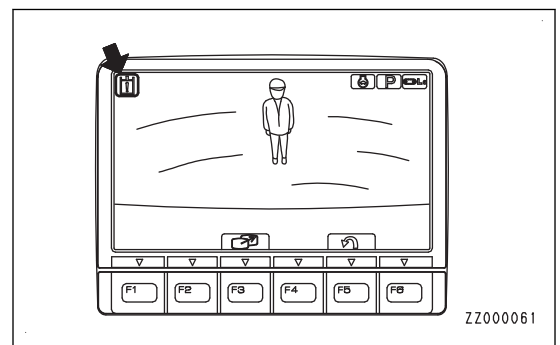

- If the caution lamp is displayed, press switch F6 to return to the standard screen, and check the content of the abnormality or warning display.

While the caution lamp is flashing, if no lever is operated for 10 seconds or more, the screen automatically returns to the standard screen.

When the screen returns to the standard screen, the caution lamp at the top left of the screen goes out and the caution lamp and action level are displayed on the left part of the screen.

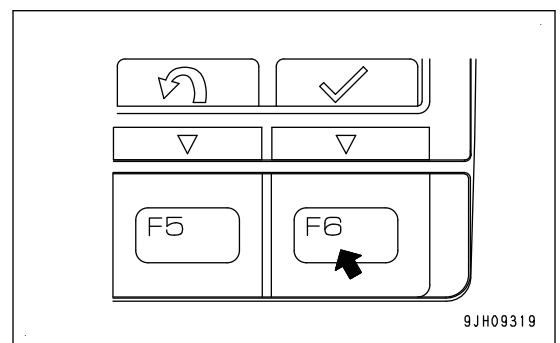



- If a caution lamp is displayed, move the machine, set it in a safe posture, then have inspection performed immediately.

**USER MENU DISPLAY SWITCH**

On the standard screen, press switch F6 to display the user menu screen on which you can make various settings for the machine in the monitor display.

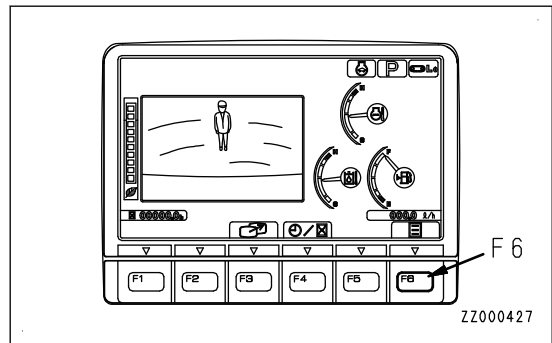

**USER MENU**

The user menu consists of the following kinds. Press switches F1 and F2 to move to right and left for selecting menu screens.

- (a): “Energy Saving Guidance”
- (b): “Machine Setting”
- (c): “Maintenance”
- (d): “Monitor Setting”
- (e): Mail Check

These menus (a) to (e) are for setting and confirming the following items:

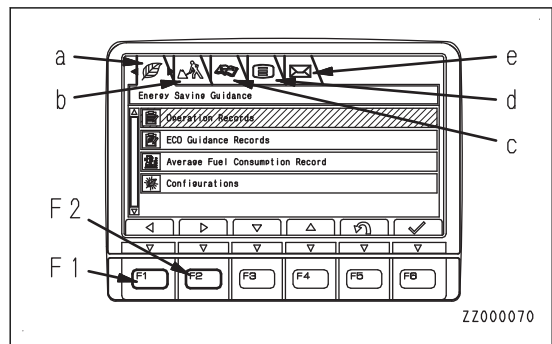

For operations in each menu, see the detailed explanation pages of respective items.

**(a) “Energy Saving Guidance”**

- Check of “Operation Records”
- Check of “ECO Guidance Records”
- Check and reset of “Average Fuel Consumption Record”
- “Configurations”

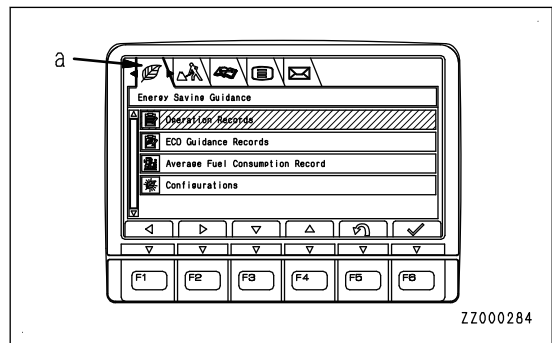

**(b) “Machine Setting”**

- “Economy Mode Adjustment”
- “Breaker Setting”
- “Attachment Setting”
- “Auto Idle Stop Timer Setting”

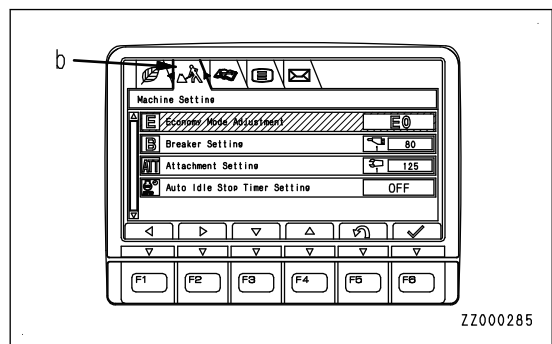

**(c) Maintenance**

- Check and reset of various maintenance times

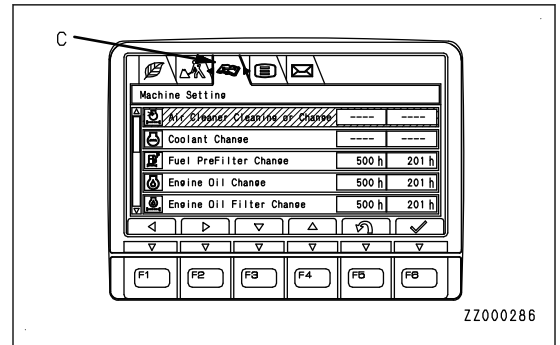

**(d) "Monitor Setting"**

- "Screen Adjustment"
- "Screen Adjustment (Camera)"
- "Clock Adjustment"
- "Language"
- "Operator ID"

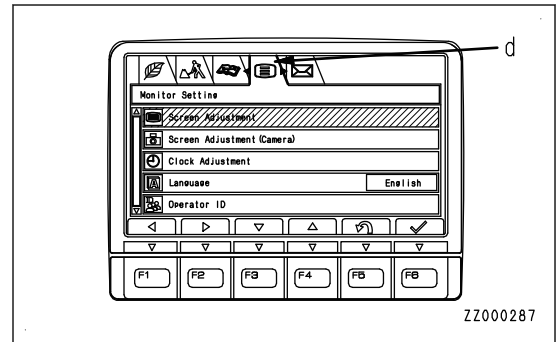

**(e) Mail Check**

- Check of mail contents and reply to mail

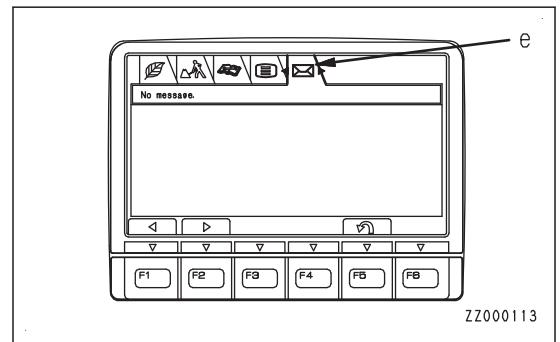

On the user menu screen, it is possible to perform the following operations with switches F1 to F6.

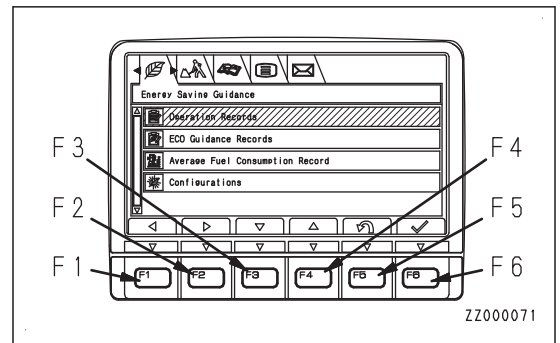

F1: Moves to the left menu. When on the left end menu, it moves to the right end menu.

F2: Moves to the right menu. When on the right end menu, it moves to the left end menu.

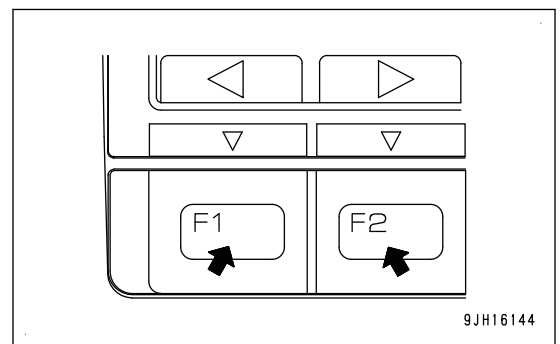

F3: Moves to the next item (1 line below). When on the last line, it moves to the first line.

F4: Moves to the previous item (1 line above). When on the first line, it moves to the last line.

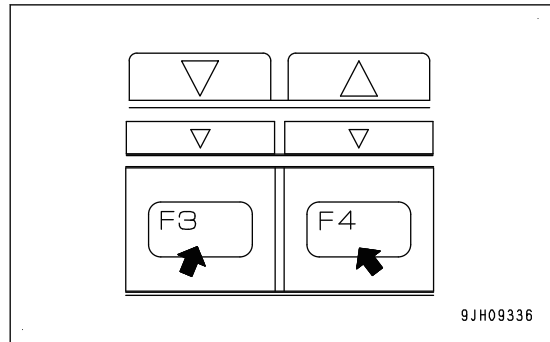

F5: Returns the screen to the standard screen.

F6: Displays the setting screen for selected item.

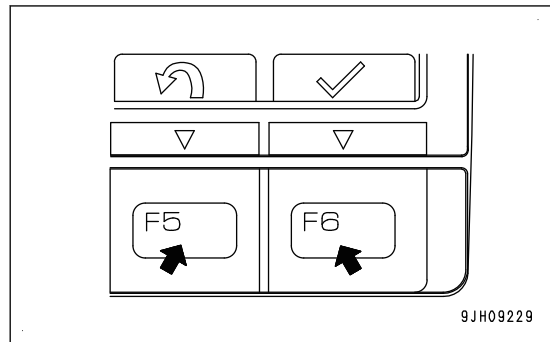

If no switch is operated for 30 seconds on the user menu screen, the screen automatically returns to the previous screen.

### ENERGY SAVING GUIDANCE

Each item of “Energy Saving Guidance” menu (a) is used for displaying and setting the notification relevant to energy saving.

- Check of “Operation Records”
- Check of “ECO Guidance Records”
- Check and reset of “Average Fuel Consumption Record”
- “Configurations”

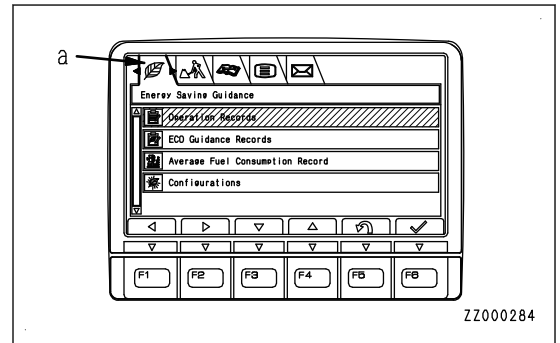

### CHECK OPERATING RECORD

Select “Operation Records” (1) from “Energy Saving Guidance” menu screen, then press switch F6.

On “Operation Records” menu, “working hours”, “Average Fuel Consumption”, “Actual working hours”, “Ave. Fuel Consumption (Actual Working)”, “Fuel Consumption”, “Idling Hours” and “E mode time ratio” on daily basis or on a split measurement period basis are displayed.

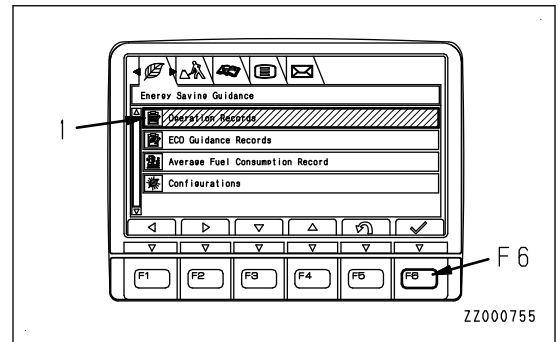

### Operation on “Operation Records” screen

On “Operation Records” screen, you can perform the following operations by pressing switch F3 to F5.

F3: Displays the next page. When on the last page, it displays the first page.

F4: Displays the previous page. When on the first page, it displays the last page.

F5: Returns the screen to “Energy Saving Guidance” menu screen.

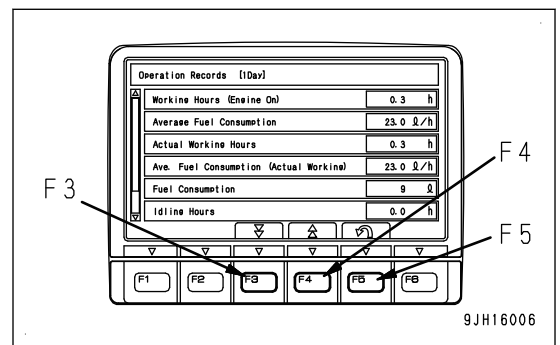

### CHECK ECO GUIDANCE RECORD

Select “ECO Guidance Records” (2) from “Energy Saving Guidance” menu screen, then press switch F6.

On the “ECO Guidance Records” menu, display the frequency of display of the ECO guidance on a daily basis or during the split measurement period.

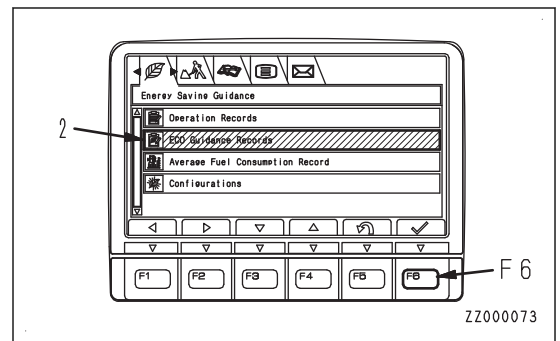

### Operations on “ECO Guidance Records” screen

Press switch F5 to perform the following operation on “ECO Guidance Records” screen.

F5: Returns the screen to “Energy Saving Guidance” menu screen.

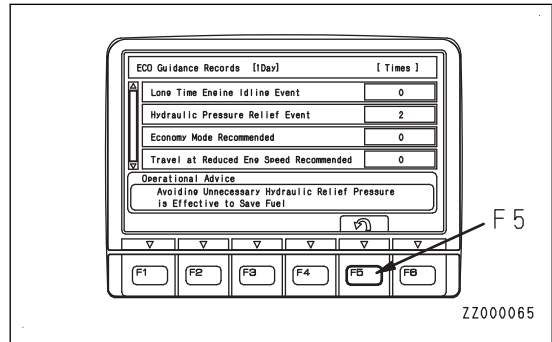

### REMARK

ECO guidance denotes displaying the guidance for energy saving operation. This display may appear on the standard screen while the machine is in operation.

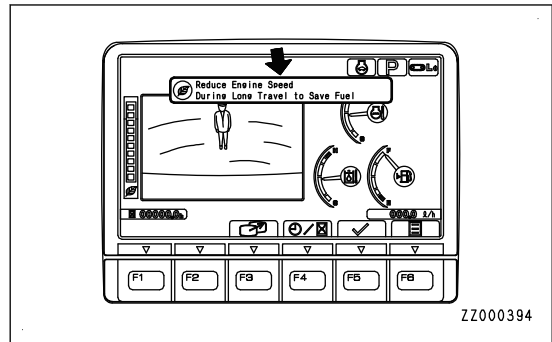

### CHECK FUEL CONSUMPTION RECORD

Select “Average Fuel Consumption Record” (3) from “Energy Saving Guidance” menu screen, then press switch F6.

On “Average Fuel Consumption Record” menu, display the graph of hourly average fuel consumption during “Last 12 hours” or the graph of daily fuel consumption “Last 7 days”.

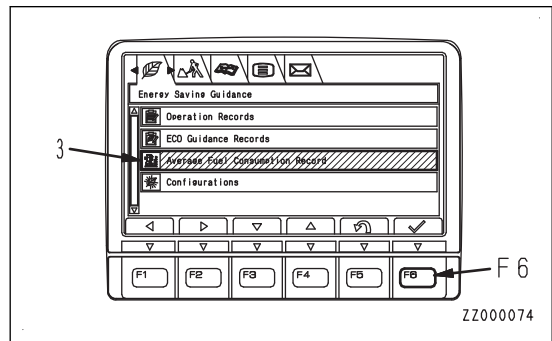

### Operation on “Average Fuel Consumption Record” screen

Press switch F1, F2 or F5 on “Average Fuel Consumption Record” screen to perform the following operations.

F1: Clears the graph data.

F2: Switches graphical displays of the average fuel consumption.

F5: Returns the screen to “Energy Saving Guidance” menu screen.

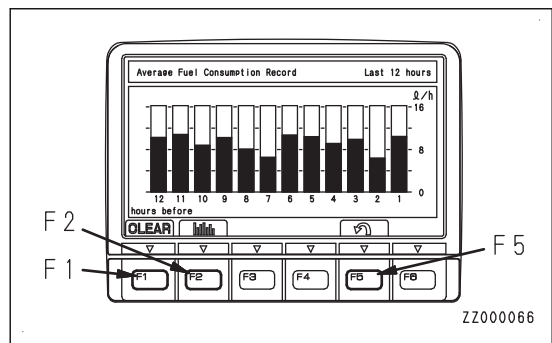

### REMARK

The displayed value of fuel consumption may differ from the actual value due to the operating conditions of the customers (fuel, weather or work contents, etc.).

### Switching of displayed graph

Press F2 on “Average Fuel Consumption Record” screen to change the currently displayed graph to another.

**REMARK**

There are 2 types of graphs. One shows hourly average fuel consumption during “Last 12 hours” and the other is daily average fuel consumption during “Last 7 days”. Switching between them is available.

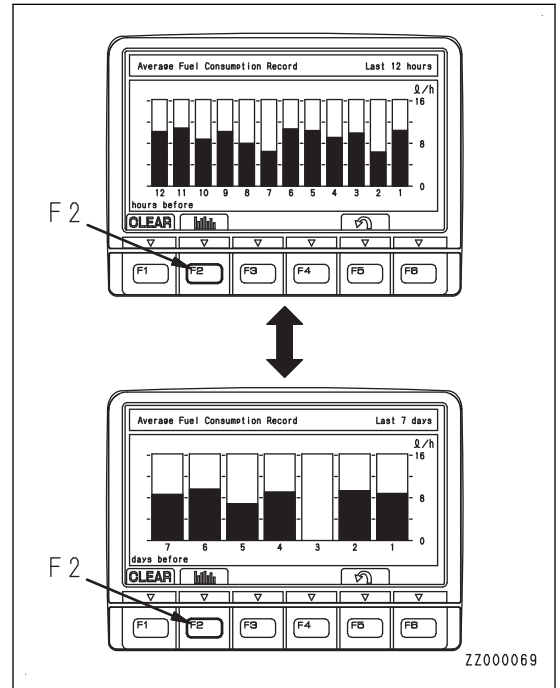

### Deleting “Average Fuel Consumption Record”

1. When switch F1 (“CLEAR”) is pressed, the reconfirmation screen shown in the figure is displayed.
2. When the switch F6 is pressed, graphs of data of “Last 12 hours” and “Last 7 days” are both deleted, and the screen returns to the “Average Fuel Consumption Record” screen.

**REMARK**

When canceling data deletion (clear), press switch F5.

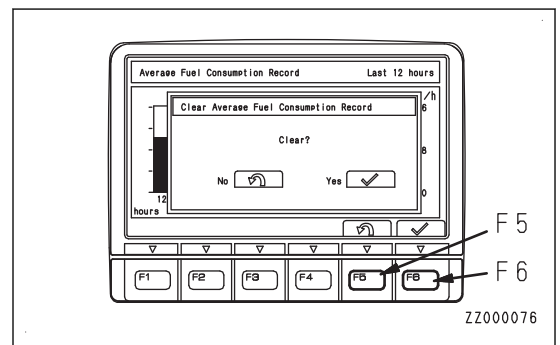
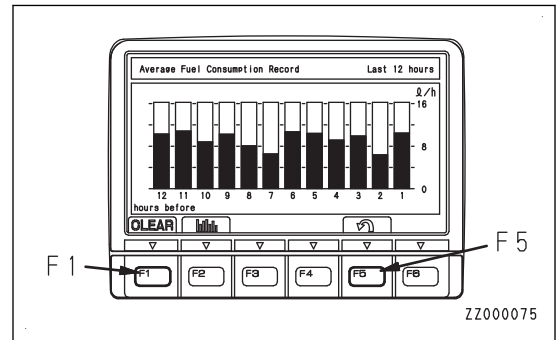

### CHANGE DISPLAY SETTING

Select "Configurations" (4) from "Energy Saving Guidance" menu screen, then press switch F6.

On "Configurations" menu, following operations are available.

- Setting "Average Fuel Consumption Display"
- Switching "ECO Gauge Display"/Non-display
- Setting "ECO Gauge Display Fuel Target Value"
- Switching "ECO Guidance Display"/Non-display
- Switching "ECO Guidance Display at Key OFF"/Non-display

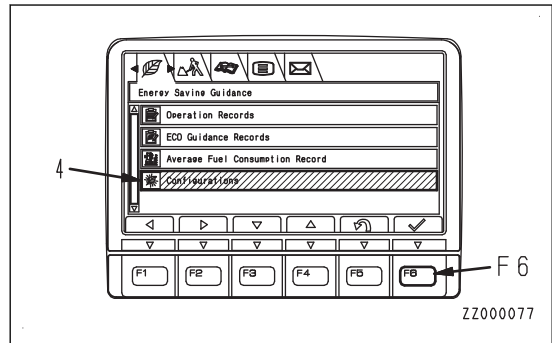

### Operations on "Configurations" screen

On "Configurations" screen, it is possible to perform the following operations with switches F3 to F6.

F3: Moves to the next item (1 line below). When on the last line, it moves to the first line.

F4: Moves to the previous item (1 line above). When on the first line, it moves to the last line.

F5: Returns the screen to the Energy Saving Guidance menu screen.

F6: Displays the setting screen for selected item.

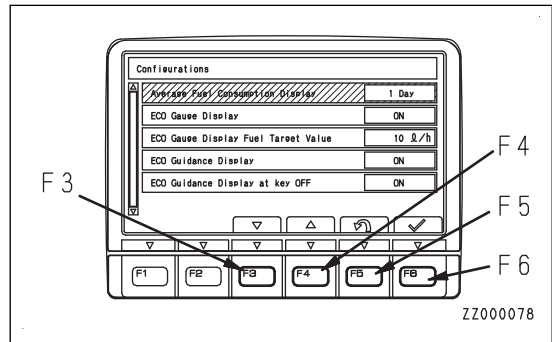

### SET DISPLAY OF FUEL CONSUMPTION GAUGE

It is possible to change the display of fuel consumption gauge (5) and the setting of Display/Non-display.

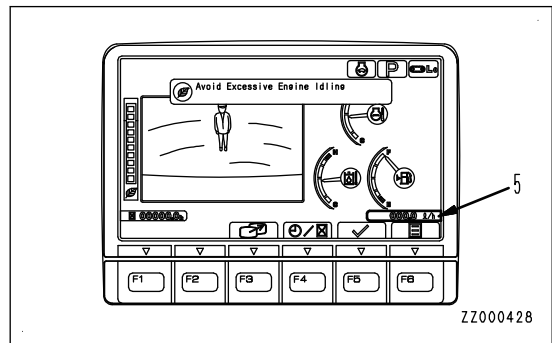

1. Select "Average Fuel Consumption Display" (6) from "Configurations" screen, then press switch F6.

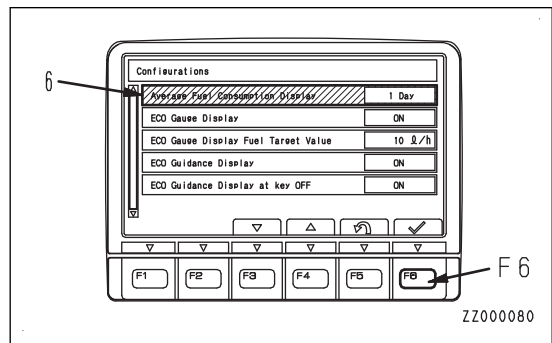

2. "Average Fuel Consumption Display" screen appears.
  - "1 Day"
 

Displays the average fuel consumption from 0:00 a.m. of the day to 0:00 a.m. of the next day.
  - "Split Time"
 

Displays the average fuel consumption during "Split Time" measurement period. Select "Split Time" to start the automatic measurement of fuel consumption.
  - "Not Use"
 

Does not display the fuel consumption gauge.

**REMARK**

When you select "Split Time" measurement, the measurement stop switch ("STOP") is displayed on "Operation Records" screen and "ECO Guidance Records" screen. When you stop the measurement, move from "Energy Saving Guidance" menu (a) screen to "Operation Records" (1) screen or "ECO Guidance Records" (2) screen, then press the measurement stop switch F1 ("STOP").

On this screen, it is possible to perform the following operations with switches F3 to F6.

- F3: Moves to the next item (1 line below). When on the last line, it moves to the first line on the next page.
- F4: Moves to the previous item (1 line above). When on the first line, it moves to the last line on the previous page.
- F5: Cancels the setting and returns the screen to "Configurations" screen.
- F6: Changes the setting and returns the screen to "Configurations" screen.

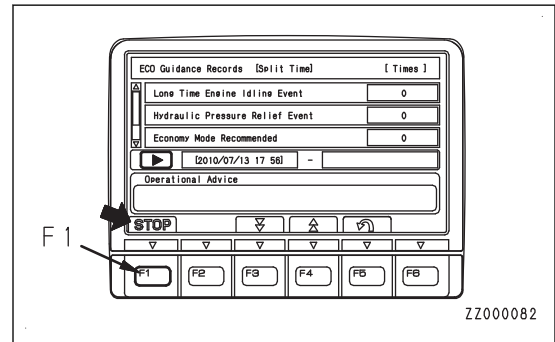
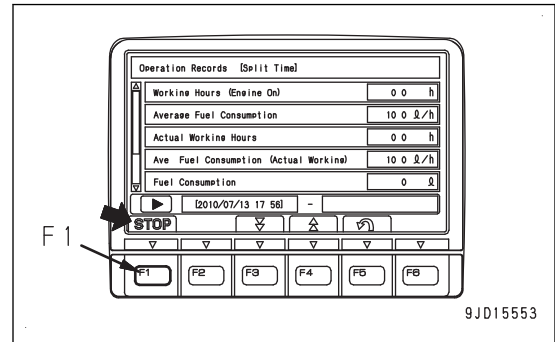
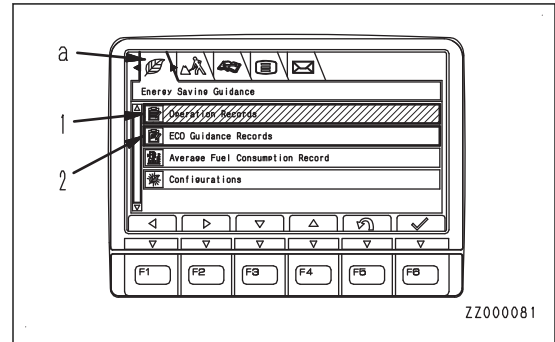
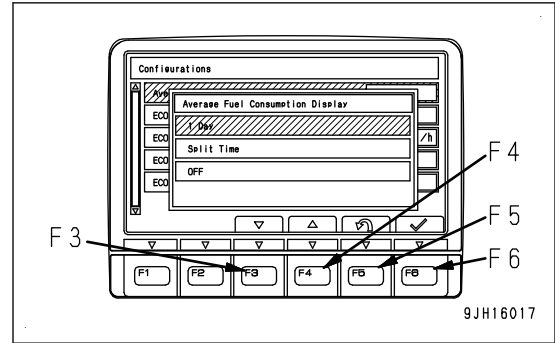



### SWITCH DISPLAY/NON-DISPLAY OF ECO GAUGE

It is possible to change the setting of Display/Non-display of ECO gauge (7).

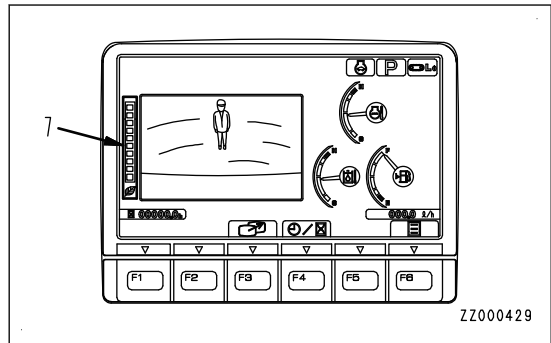

1. Select "ECO Gauge display" (8) from "Configurations" screen, then press switch F6.

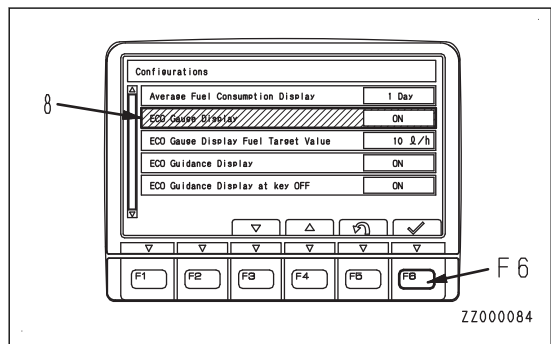

2. "ECO Gauge Display" setting screen appears.
  - "ON": Displays the ECO gauge (7) on the standard screen.
  - "OFF": Does not display ECO gauge (7) on the standard screen.

On this screen, it is possible to perform the following operations with switches F3 to F6.

F3: Moves to the next item (1 line below). When on the last line, it moves to the first line.

F4: Moves to the previous item (1 line above). When on the first line, it moves to the last line.

F5: Cancels the setting and returns the screen to "Configurations" screen.

F6: Changes the setting and returns the screen to "Configurations" screen.

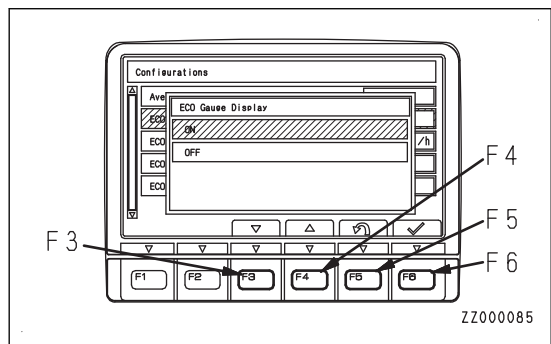

### SET TARGET FUEL CONSUMPTION VALUE DISPLAYED IN ECO GAUGE

It is possible to change the target fuel consumption value (the upper limit value of the green range) of the ECO gauge (7).

1. Select the target fuel consumption value displayed in "ECO Gauge Display Fuel Target Value" (9) from "Configurations" screen, then press switch F6.

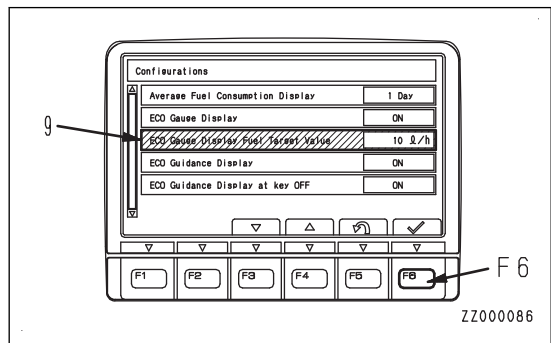

2. "ECO Gauge Display Fuel Target Value" appears.  
 On this screen, it is possible to perform the following operations with switches F3 to F6.  
 F3: Decreases the target fuel consumption value by 1 l/h.  
 F4: Increases the target fuel consumption value by 1 l/h.  
 F5: Cancels the setting and returns the screen to "Configurations" screen.  
 F6: Changes the setting and returns the screen to "Configurations" screen.

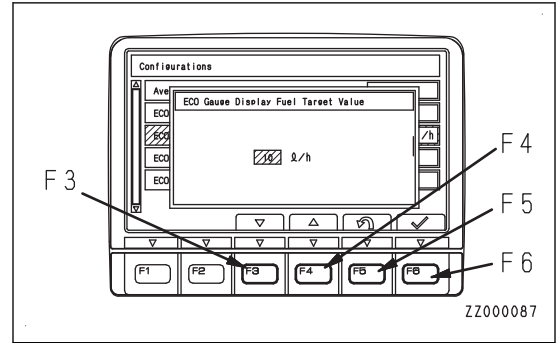

**SWITCH DISPLAY/NON-DISPLAY OF ECO GUIDANCE**

It is possible to change the setting of Display/Non-display of ECO guidance (10).

1. Select "ECO Guidance display" (11) from "Configurations" screen, then press switch F6.

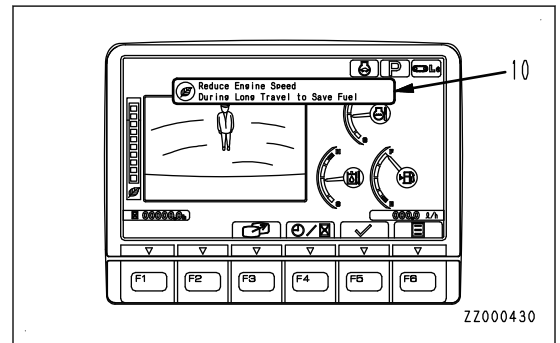

2. "ECO Guidance Display" setting screen appears.
  - "ON": Displays ECO Guidance (10) on the standard screen.
  - "OFF": Does not display ECO Guidance (10) on the standard screen.

On this screen, it is possible to perform the following operations with switches F3 to F6.

- F3: Moves to the next item (1 line below). When on the last line, it moves to the first line on the next page.
- F4: Moves to the previous item (1 line above). When on the first line, it moves to the last line on the previous page.
- F5: Cancels the setting and returns the screen to "Configurations" screen.
- F6: Changes the setting and returns the screen to "Configurations" screen.

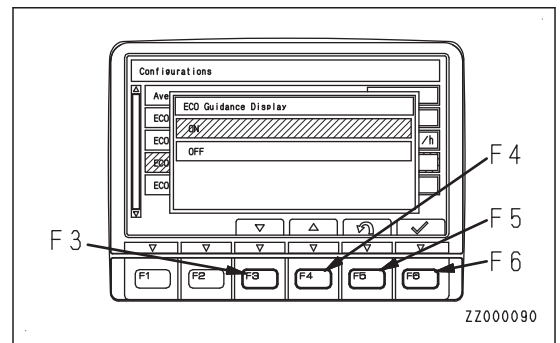
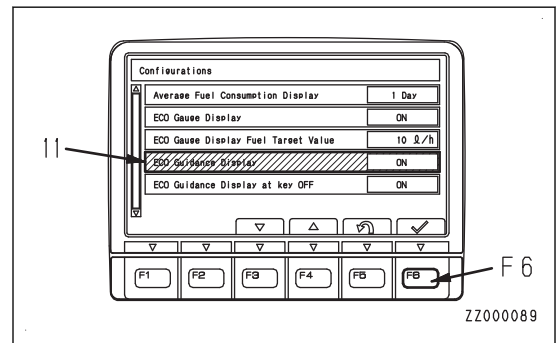

### SWITCH DISPLAY/NON-DISPLAY OF GUIDANCE WHEN KEY IS OFF

It is possible to change the setting of Display/Non-display of guidance (12) when the starting key is turned off.

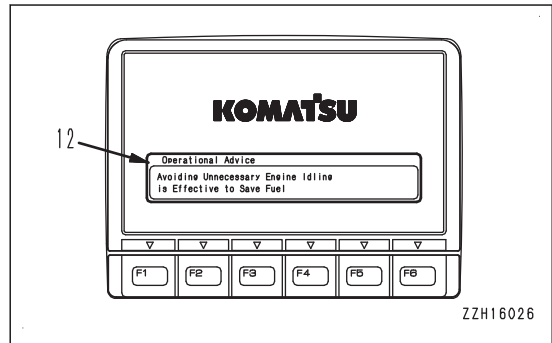

1. Select "ECO Guidance Display at Key OFF" (13) from "Configurations" screen, then press switch F6.

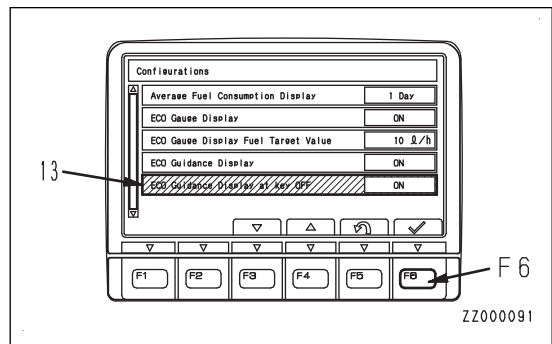

2. The setting screen for "ECO Guidance Display at Key OFF" appears.
  - "ON": Displays ECO Guidance (12) on the end screen.
  - "OFF": Does not display ECO Guidance (12) on the end screen.

On this screen, it is possible to perform the following operations with switches F3 to F6.

F3: Moves to the next item (1 line below). When on the last line, it moves to the first line on the next page.

F4: Moves to the previous item (1 line above). When on the first line, it moves to the last line on the previous page.

F5: Cancels the setting and returns the screen to "Configurations" screen.

F6: Changes the setting and returns the screen to "Configurations" screen.

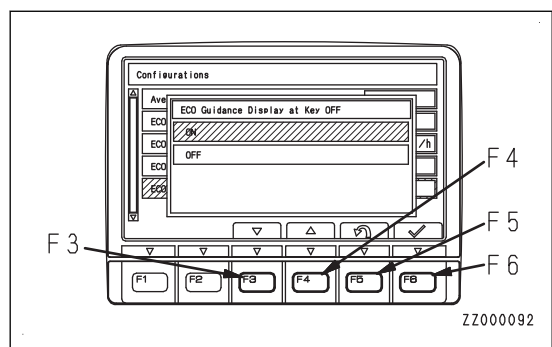

### MACHINE SETTINGS

Each item of “Machine Setting” menu (b) is used for setting items of machine.

- “Economy Mode Adjustment”
- “Breaker Setting”
- “Attachment Setting”
- “Auto Idle Stop Timer Setting”

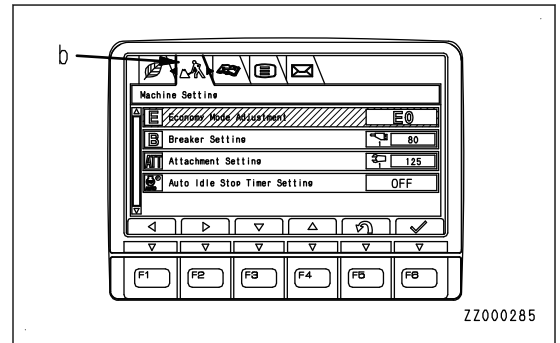

### ADJUST ECONOMY MODE

Select “Economy Mode Adjustment” (1) on “Machine Setting” menu screen, then press switch F6.

On the “Economy Mode Adjustment menu”, you can adjust the engine output in E mode.

In the Economy Mode, the higher the selected number starting from E0 becomes, the lower the engine output becomes. In the meantime, the better the fuel efficiency becomes.

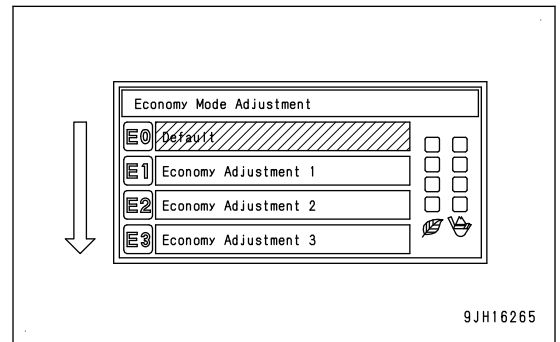
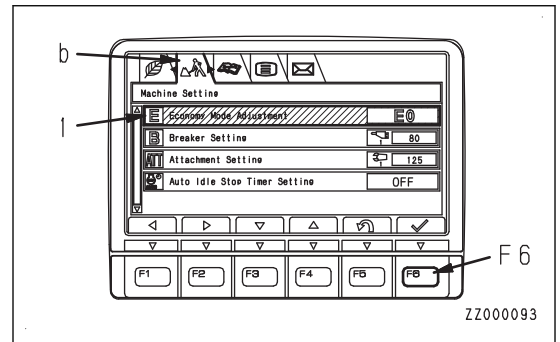

### Operation on “Economy Mode Adjustment” screen

On “Economy Mode Adjustment” screen, you can perform the following operations with switches F3 to F6.

F3: Moves to the next item (1 line below). When on the last line, it moves to the first line.

F4: Moves to the previous item (1 line above). When on the first line, it moves to the last line.

F5: Cancels the selection and returns the screen to “Machine Setting” menu screen.

F6: Selects the Adjustment Mode and returns the screen to “Machine Setting” menu screen.

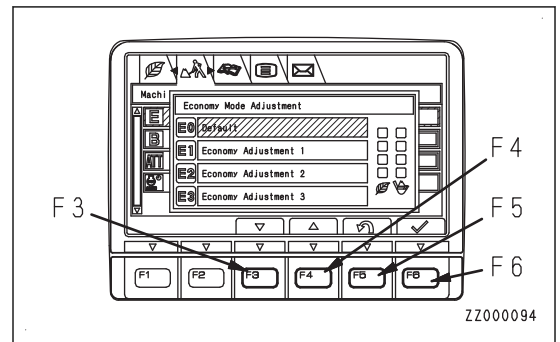

### BREAKER SETTING

On the “Breaker Setting” menu, you can change the name of breaker displayed on the timer monitor and the breaker oil flow setting.

For machines that have no attachment, the “Breaker Setting” menu is not displayed.

1. Select “Breaker Setting” (2) on “Machine Setting” (b) screen, then press switch F6.

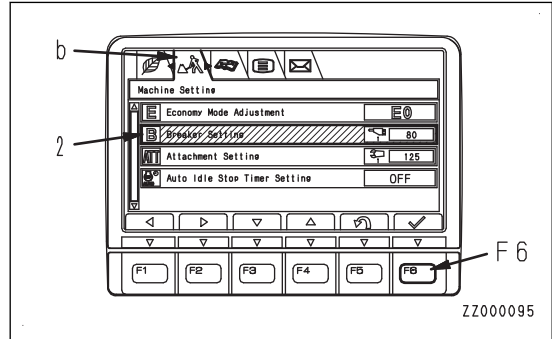

2. On “Breaker Setting” screen shown in the figure, select breaker, and press switch F6.

On the “Breaker Setting” screen shown in the figure, you can perform the following operations with switches F1 to F6.

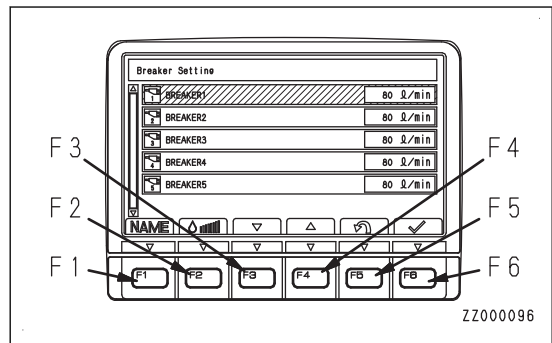

- F1: Changes the name of the selected breaker setting.
- F2: Changes the oil flow rate of the selected breaker setting.
- F3: Moves to the next item (1 line below). When on the last line, it moves to the first line.
- F4: Moves to the previous item (1 line above). When on the first line, it moves to the last line.
- F5: Cancels the selection and returns the screen to “Machine Setting” menu screen.
- F6: Allocates the selected setting to the setting when B mode is selected.

### Changing the Breaker Setting name

You can change the Breaker Setting name as you like.

You can use alphabet letters A to Z, Arabic numerals 0 to 9, symbols #, \*, +, -, and /, and the space.

1. On “Breaker Setting” screen, select a breaker to change its name, then press switch F6.

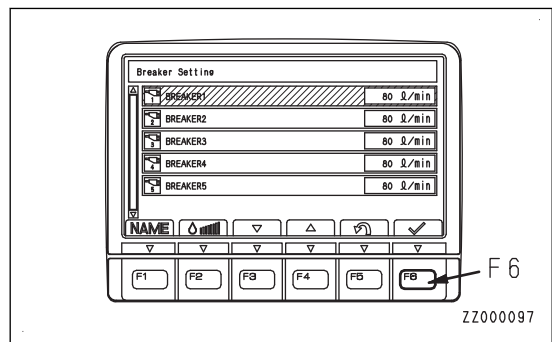

2. The “Breaker Name Setting” screen is displayed. On the “Breaker Name Setting” screen, you can perform the following operations with switches F1 to F6.

- F1: “CLEAR” Clears all the letters. (If some letters are left.)
- F1: “DEFAULT” Displays the initial name. (If all the letters are deleted.)
- F2: Moves to the right letter.
- F3: Moves to the next alphabet, numeral, or symbol.
- F4: Moves to the previous alphabet, numeral, or symbol.

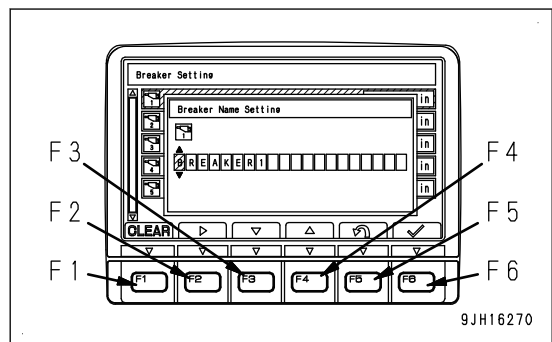

F5: Returns the screen to the “Breaker Setting” screen without changing the name.

F6: Enters the change and returns the screen to the “Breaker Setting” screen.

### Changing Breaker Oil Flow Rate Setting

1. On “Breaker Setting” screen, select a breaker to change its oil flow, then press switch F2.

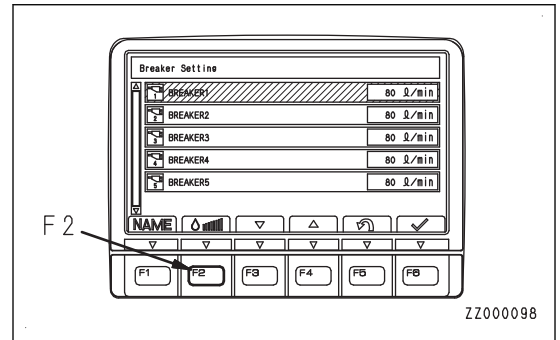

2. The “Breaker Oil Flow Rate Setting” screen is displayed.

On the “Breaker Oil Flow Rate Setting” screen, you can perform the following operations with switches F3 to F6.

F3: Decreases the flow rate by 1 level.

F4: Increases the flow by 1 level.

F5: Returns the screen to the “Breaker Setting” screen without changing the oil flow.

F6: Enters the oil flow rate setting and returns the screen to the “Breaker Setting screen”.

(X): Present oil flow setting

(Y): Min. oil flow for adjustment

(Z): Max. oil flow for adjustment

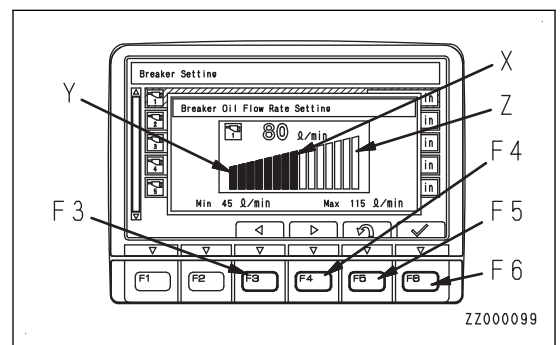

### ATTACHMENT SETTING

On machines ready for installation of attachment, you can adjust the oil flow rate in ATT/P mode and ATT/E mode to match the attachment on the “Attachment Setting” menu.

For machines that have no attachment, the “Attachment Setting” menu is not displayed.

1. Select “Attachment Setting” (3) on “Machine Setting” (b) screen, then press switch F6.

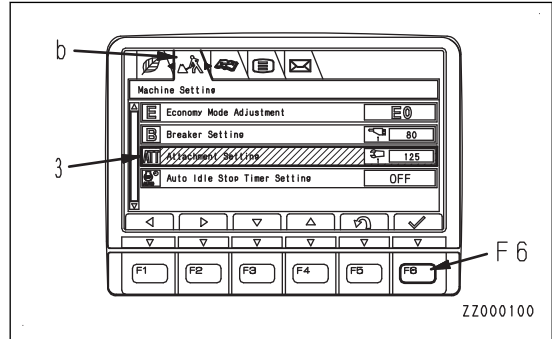

2. On “Attachment Setting” screen shown in the figure, select an attachment to adjust and press switch F6.

On “Attachment Setting” screen shown in the figure, you can perform the following operations with switches F1 to F6.

F1: Changes the name of the selected attachment setting.

F2: Changes the oil flow rate of the selected attachment setting.

F3: Moves to the next item (1 line below). When on the last line, it moves to the first line.

F4: Moves to the previous item (1 line above). When on the first line, it moves to the last line.

F5: Cancels the selection and returns the screen to “Machine Setting” menu screen.

F6: Allocates the selected setting to that of ATT/P or ATT/E mode.

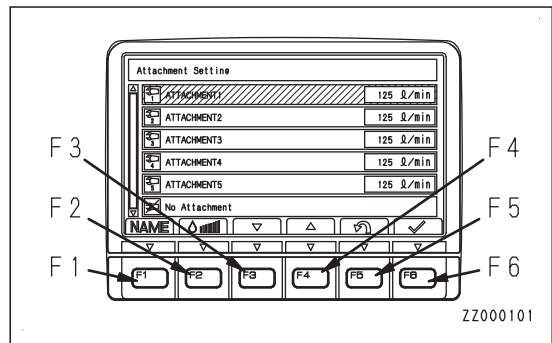

### Changing Attachment Setting name

You can change the name for Attachment Setting name as you like.

You can use alphabet letters A to Z, Arabic numerals 0 to 9, symbols #, \*, +, -, and /, and the space.

1. Select an attachment to change its name on “Attachment Setting” screen, then press switch F6.

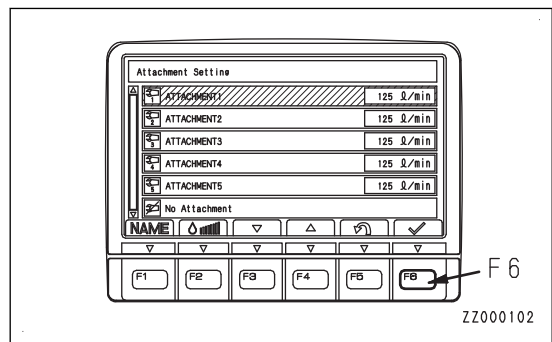

2. The “Attachment Name Setting” screen is displayed.

On the “Attachment Name Setting” screen, you can perform the following operations with switches F1 to F6.

F1: “CLEAR” Clears all the letters. (If some letters are left.)

F1: “DEFAULT” Displays the initial name. (If all the letters are deleted.)

F2: Moves to the right letter.

F3: Moves to the next alphabet, numeral, or symbol.

F4: Moves to the previous alphabet, numeral, or symbol.

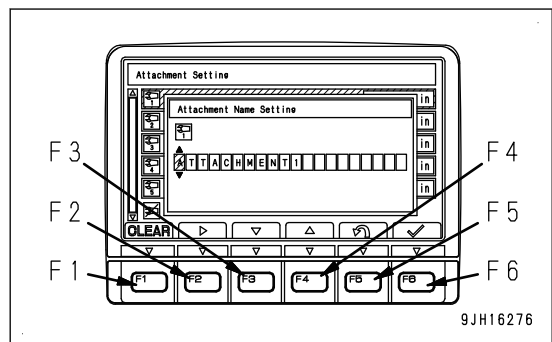

F5: Returns the screen to “Attachment Setting” screen without changing the name.

F6: Enters the change and returns the screen to “Attachment Setting” screen.

It is not possible to change the name for “No Attachment” setting.

### Changing “2-Way Attachment Oil Flow Rate Setting”

1. Select an attachment to change its oil flow on “Attachment Setting” screen, then press switch F2.

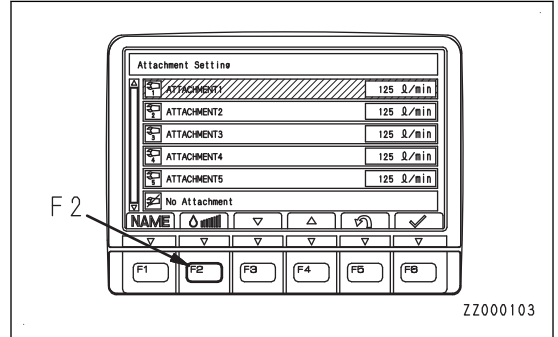

2. The “2-Way Attachment Oil Flow Rate Setting” screen is displayed.

On the “2-Way Attachment Oil Flow Rate Setting” screen, you can perform the following operations with switches F3 to F6.

F3: Decreases the oil flow rate by 1 level.

F4: Increases the oil flow rate by 1 level.

F5: Returns to the “Attachment Setting” screen without changing the oil flow rate.

F6: Enters the oil flow setting and returns to the “Attachment Setting” screen.

(X): Present oil flow setting

(Y): Min. oil flow for adjustment

(Z): Max. oil flow for adjustment

It is not possible to change the oil flow for “No Attachment” setting.

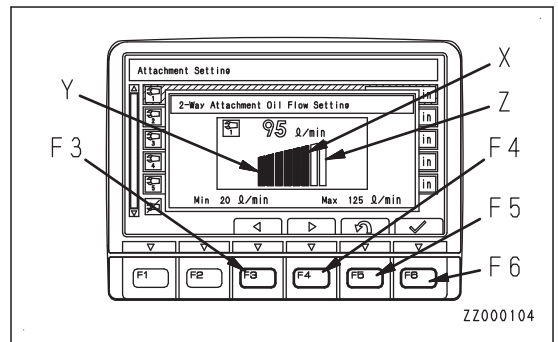



### AUTO IDLE STOP TIMER SETTING

The auto idle stop function stops the engine automatically when the engine is operated continuously at idle with the lock lever in LOCK position for a set time.

The auto idle stop function operates only when the following conditions are satisfied.

- The engine is running normally.
- The lock lever is in LOCK position.
- The engine coolant and hydraulic oil are not overheating.
- The engine is not in warm-up operation.
- The machine is not in L mode.

You can set the time to operate the auto idle stop function on the “Auto Idle Stop Timer Setting”.

1. Select “Auto Idle Stop Timer Setting” (5) on the “Machine Setting menu” (b) screen, and then press switch F6.

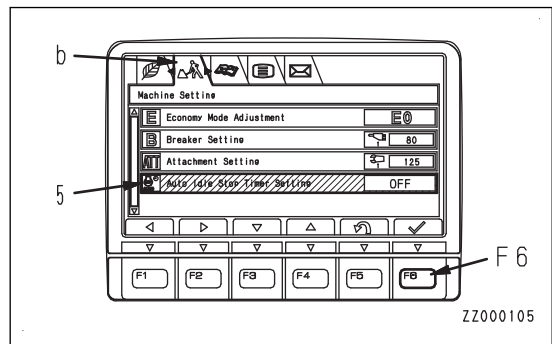

2. Select the set time on the “Auto Idle Stop Timer Setting” screen shown in the figure, and then press switch F6.

On the “Auto Idle Stop Timer Setting” screen shown in the figure, you can perform the following operations with switches F3 to F6.

F3: Moves to the next item (1 line below). When on the last line, it moves to the first line.

F4: Moves to the previous item (1 line above). When on the first line, it moves to the last line.

F5: Cancels the selection and returns the screen to “Machine Setting” menu screen.

F6: Allocates the selected setting to that of the Auto Idle Stop Timer Setting.

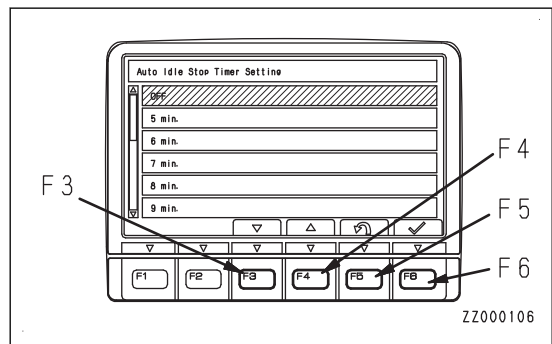

**REMARK**

- Choosing “OFF” disables operation of the auto idle stop function.
- You cannot select a time longer than that specified in the Service Menu.

3. When the idling time reaches 30 seconds before the set time, the monitor returns to the standard screen and changes to the countdown screen.

If you set the lock lever to FREE position, countdown stops and the screen returns to the standard screen.

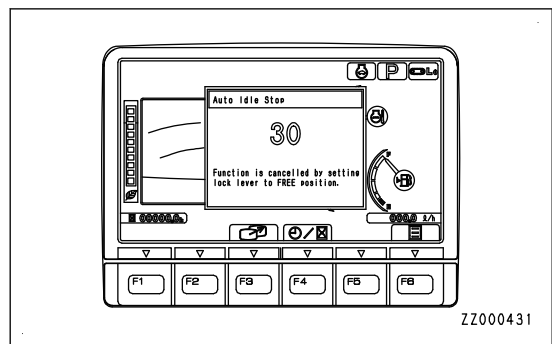

4. When countdown reaches 0, the engine stops and the screen changes to the Auto Idle Stop in Operation screen.
5. To prevent battery discharging, turn off unnecessary switches.

**REMARK**

While the auto idle stop is activated, only the engine is stopped and the machine monitor, inverter, etc., as well as the electrical components including the air conditioner, radio, lamps, and wipers keep their states before the engine is stopped.

6. To prevent causing flat battery, turn the starting switch to OFF position.
7. When restarting the engine, turn the starting switch as usual.

**REMARK**

While the auto idle stop function is ON, the number of the times that the engine was stopped when it was not at low idle (the engine speed is 1400 rpm or higher) is displayed as "L01" at and after 1000 and as "L03" at and after 2000 on the monitor.

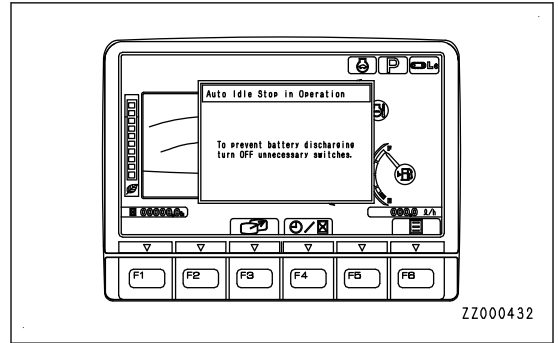

ZZ000432

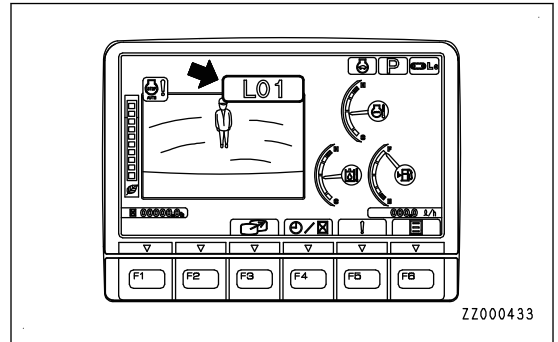

ZZ000433

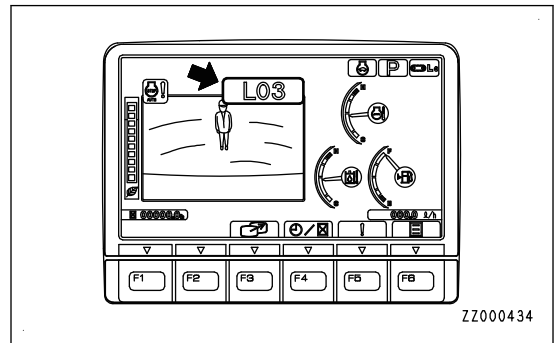

ZZ000434

### MAINTENANCE SCREEN SETTING

Each item of this menu (c) is used for displaying and setting the notification relevant to maintenance.

The items on “Maintenance” display are as follows.

A	B
Air Cleaner Clean or Change	-
Coolant Change	-
Fuel Prefilter Change	500
Engine Oil Change (*1)	500
Engine Oil Filter Change (*1)	500
Hydraulic Tank Breather Change	500
Fuel Main Filter Change	1000
Hydraulic Oil Filter Change	1000
Damper Case Oil Check/Refilling	1000
Swing Machinery Case Oil Change	1000
Final Drive Case Oil Change	1000
KCCV Filter Change	2000
Hydraulic Oil Change	5000

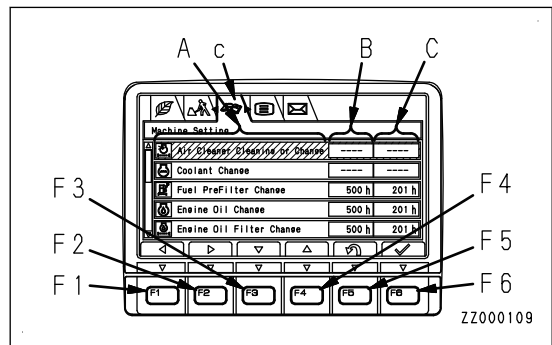

A: Maintenance item

B: Default maintenance interval settings (h)

C: Time remaining until maintenance (h)

\*1:

When using engine oil for cold district, the maintenance interval setting must be changed.

On “Maintenance” menu screen, it is possible to perform the following operations with switches F1 to F6.

F1, F2: Moves to the right and left menus.

F3: Moves to the next item (1 line below). When on the last line, it moves to the first line.

F4: Moves to the previous item (1 line above). When on the first line, it moves to the last line.

F5: Returns the screen to the standard screen.

F6: If this switch is kept pressed, the screen changes to the screen for resetting the remaining time to the maintenance for the selected item.

#### REMARK

When resetting the remaining time to the maintenance, keep switch F6 pressed for at least 1.5 seconds. If this time is short, the switch operating sound can be heard, but the screen does not switch to the screen for resetting the remaining time to the maintenance.

- If no switch is operated for 30 seconds on the “Maintenance” menu screen, the screen automatically returns to the standard screen.
- When the maintenance time caution lamp is lit on the standard screen, press F6 on the standard screen and the screen automatically displays “maintenance” menu screen.
- On “Maintenance” menu screen, if the time remaining to the maintenance for any item is less than 30 hours (initial setting value), the remaining time display (c) is highlighted in yellow. If the time remaining to the maintenance is less than 0 hours, display (C) is highlighted in red.
- If you want to change the setting for the maintenance time or maintenance notice time (initial setting: 30 hours), consult your Komatsu distributor.

## Operations on “Maintenance Due Time Reset” screen

On the “Maintenance” menu screen, if switch F6 is kept pressed for at least 1.5 seconds, the screen changes to the “Maintenance Due Time Reset” screen.

Reset the remaining time to the maintenance on this screen.

1. Press switch F6 when the Reset screen is in the condition shown in the figure.

### REMARK

- When canceling the reset, press switch F5. The screen returns to the “Maintenance” menu screen.
- On the reset screen, if no switch is operated for more than 30 seconds, the screen automatically changes to the “Maintenance” menu screen.

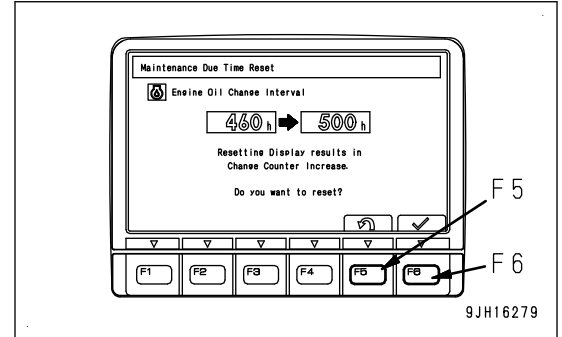

2. The reconfirmation screen is displayed.

If switch F6 is pressed again, the remaining time is reset and the screen returns to the “Maintenance” menu screen.

### REMARK

- When canceling the reset, press switch F5. The screen returns to the “Maintenance” menu screen.
- On the reconfirmation screen, if no switch is operated for more than 30 seconds, the screen automatically returns to the “Maintenance” menu screen.

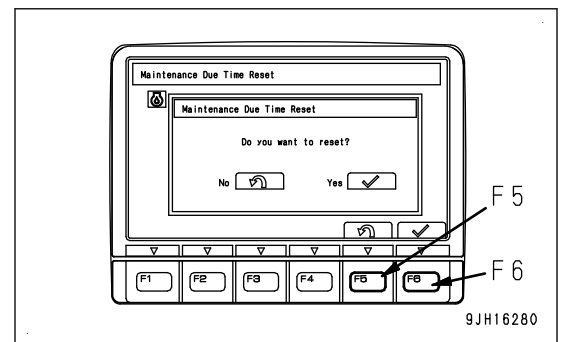

### MONITOR SETTINGS

Each item of this menu (d) is for setting the monitor.

- “Screen Adjustment”
- “Screen Adjustment (Camera)”
- “Clock Adjustment”
- “Language”
- “Operator ID”

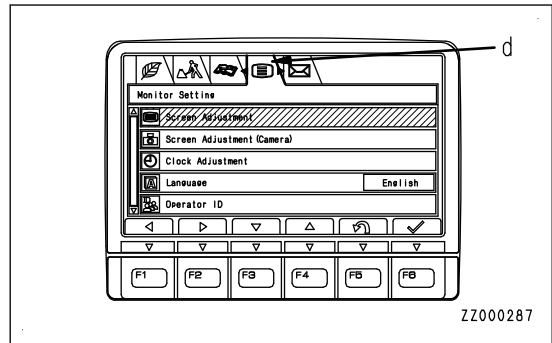

### SCREEN ADJUSTMENT

Use “Screen Adjustment” menu to adjust brightness of the monitor screen.

1. Select “Screen Adjustment” (1) on “Monitor Setting” menu screen, then press switch F6.

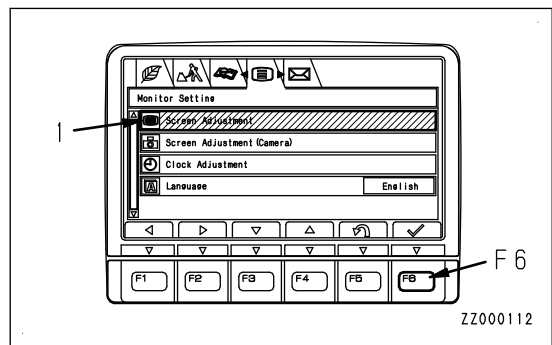

2. Use switches F2 to F6 to adjust brightness of the screen.
  - F2: Resets an adjusted value to default value.
  - F3: Moves the indicator to the left by one notch.
  - F4: Moves the indicator to the right by one notch.
  - F5: Cancels the change and returns the screen to “Monitor Setting” menu screen.
  - F6: Accepts the change and returns the screen to “Monitor Setting” menu screen.

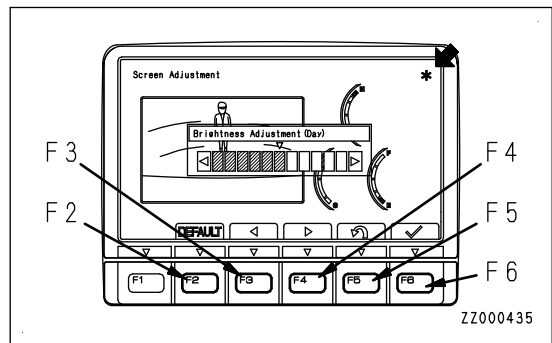

#### REMARK

- If the light switch is at night mode ON, and the screen is adjusted, it is possible to adjust the brightness of the monitor screen (night mode).
- If the light switch is at day mode ON, and the screen is adjusted, it is possible to adjust the brightness of the monitor screen (day mode).
- As long as “\*” mark is displayed in the upper right corner of the screen, brightness is automatically restricted by the machine monitor to protect the liquid crystal. “Screen Adjustment” may not change the screen brightness as long as “\*” mark is displayed. However, it is not an error.

### “Screen Adjustment (Camera)”

Use “Screen Adjustment (Camera)” to adjust brightness of the camera screen.

1. Select “Screen Adjustment (Camera)” (2) on “Monitor Setting” menu screen, then press switch F6.

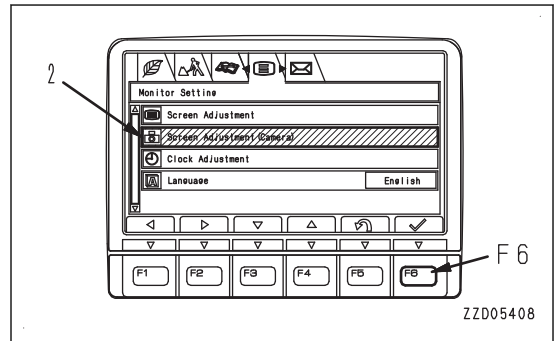

2. Use switches F2 to F6 to adjust brightness of the screen.
  - F2: Resets an adjusted value to default value.
  - F3: Moves the indicator to the left by one notch.
  - F4: Moves the indicator to the right by one notch.
  - F5: Cancels the change and returns the screen to “Monitor Setting” menu screen.
  - F6: Accepts the change and returns the screen to “Monitor Setting” menu screen.

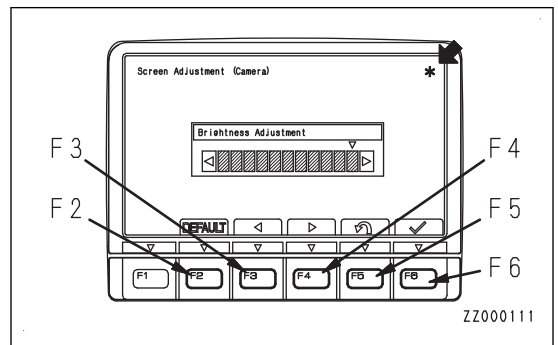

**REMARK**

As long as “\*” mark is displayed in the upper right corner of the screen, brightness is automatically restricted by the machine monitor to protect the liquid crystal. “Screen Adjustment” may not change the screen brightness as long as “\*” mark is displayed. However, it is not an error.

### CLOCK ADJUSTMENT

“Clock Adjustment” menu is used to change the setting of the clock displayed on the standard screen of the monitor.

1. Select “Clock Adjustment” (3) on “Monitor Setting” menu screen, then press switch F6. The screen switches to “Clock Adjustment” screen for selecting a menu.

The following 5 items can be changed.

- (a): “GPS Synchronization”
- (b): “Calendar”
- (c): “Time”
- (d): “12h/24h Mode”
- (e): “Daylight Saving Time”

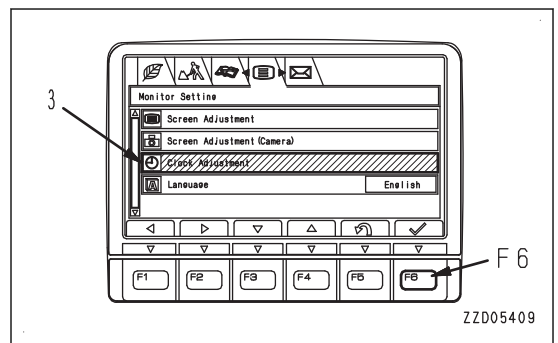

**REMARK**

- “Calendar” (b) and “Time” (c) need to be readjusted since they are reset after a long-term storage.
- When “GPS Synchronization” is set to ON, the above are automatically readjusted. While “GPS Synchronization” is ON, you cannot select the menus of “Calendar” (b) and “Time” (c).

2. Perform the following setup procedure by operating switches F3 to F6 on the selection menu screen for “Clock Adjustment”.

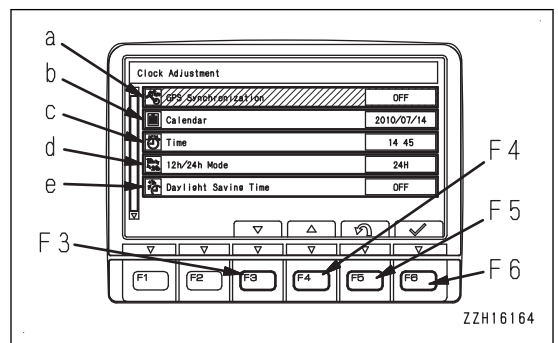

### GPS SYNCHRONIZATION SETTING

On machines equipped with KOMTRAX, turning on “GPS Synchronization” menu enables automatic setting of the monitor’s date and time in accordance with the clock of GPS.

- F3: Moves to the next item (1 line below). Moves to the top line when on the bottom line.
- F4: Moves to the previous item (1 line above). Moves to the bottom line when on the top line.
- F5: Cancels change and returns to “Clock Adjustment” screen.
- F6: Displays the setting screen for selected item.

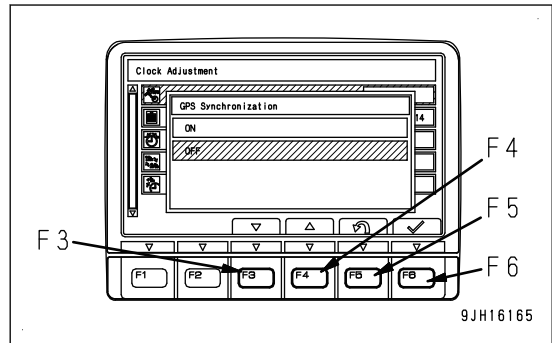

**REMARK**

- When the machine is in the environment where the radio waves from GPS cannot be received, such as inside of a building, the automatic setting function may not work.
- While “GPS synchronization” menu is turned on, the menu for “Calendar” (b) and “Time” (c) cannot be selected.

### CALENDAR SETTING

Adjust the date of the monitor.

**REMARK**

As long as “GPS Synchronization” menu is turned on, “Calendar” menu is not selectable.

1. Select “Calendar” (b) on “Clock Adjustment” screen, then press switch F6.

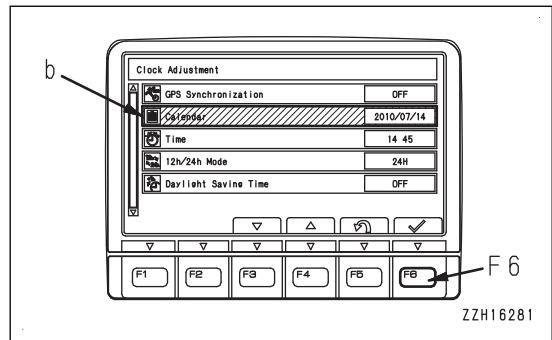

2. The “Calendar” screen is displayed.

When year display (A) is highlighted in yellow, operate the switches as follows to change year display (A). If it is not necessary to change the year setting, press switch F6.

- F3: Calendar goes back 1 year.
- F4: Calendar advances 1 year.

F5: Cancels change and returns the screen to “Clock Adjustment” screen.

F6: Proceeds to setting for month

3. When month display (B) is highlighted in yellow, operate the switches as follows to change month display (B). If it is not necessary to change the month, press switch F6.

- F3: Calendar goes back 1 month.
- F4: Calendar advances 1 month.

F5: Cancels change and returns to the year setting screen.

F6: Proceeds to setting for date.

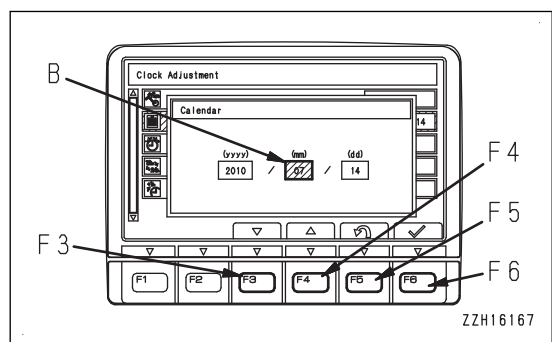
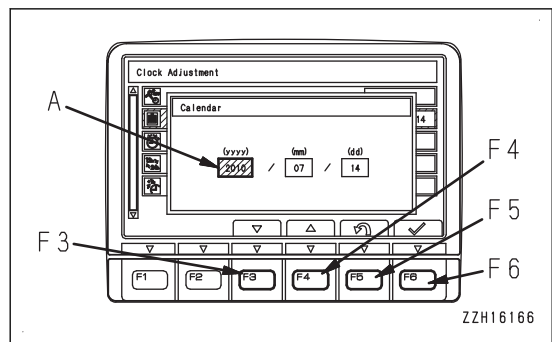

- When date display (C) is highlighted in yellow, operate the switches as follows to change day display (C). If it is not necessary to change the day, press switch F6.

F3: Calendar goes back 1 day.

F4: Calendar advances 1 day.

F5: Cancels change and returns to the month setting screen.

F6: Accepts change and returns the screen to "Clock Adjustment" screen.

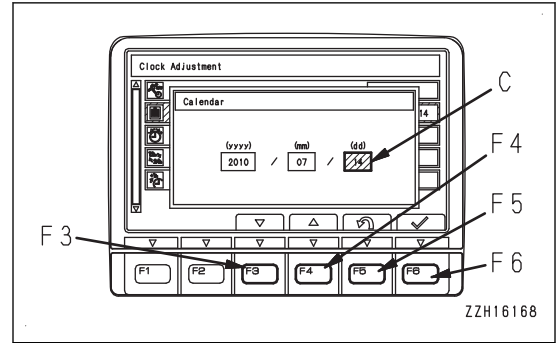

## TIME SETTING

Adjust the time of the monitor clock.

### REMARK

As long as "GPS Synchronization" is turned on, "Time" menu is not selectable.

- Select "Time" (c) on "Clock Adjustment" screen, then press switch F6.

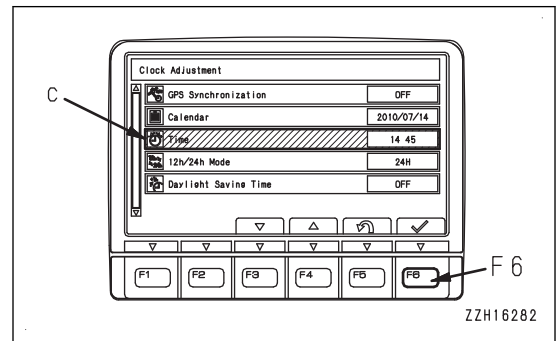

- The "Time" screen is displayed.

When the hour display (D) is highlighted in yellow, operate the switches as follows to change hour display (D). If it is not necessary to change the hour setting, press switch F6.

F3: The time goes back 1 hour.

F4: The time advances 1 hour.

F5: Cancels change and returns the screen to "Clock Adjustment" screen.

F6: Proceeds to setting for the minute.

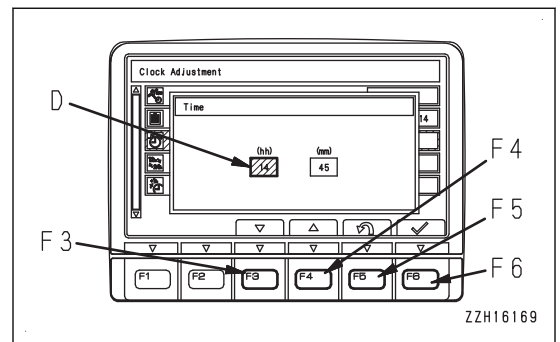

- When minute display (E) is highlighted in yellow, operate the switches as follows to change minute display (E). If it is not necessary to change the minute, press switch F6.

F3: The time goes back 1 minute.

F4: The time advances 1 minute.

F5: Cancels change and returns to the time setting screen.

F6: Accepts change and returns the screen to "Clock Adjustment" screen.

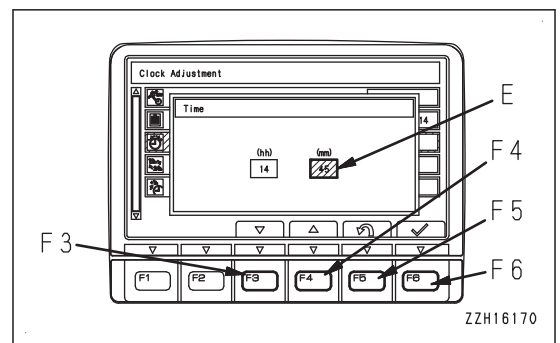



### SWITCH 12H/24H DISPLAY MODE

Choose either a 12-hour display (AM/PM) or a 24-hour display.

- 24-hour system display
  - 12-hour system display (AM/PM)
1. Select "12h/24h Mode" (d) on "Clock Adjustment" screen, then press switch F6.

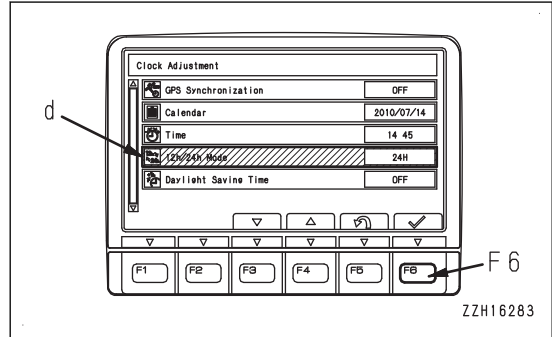

2. "12h/24h Mode" screen appears.
  - F3: Moves to the next item (1 line below). Moves to the top line when it is on the bottom line.
  - F4: Moves to the previous item (1 line above). Moves to the bottom line when it is on the top line.
  - F5: Cancels the change and returns the screen to "Clock Adjustment" screen.
  - F6: Accepts change and returns to "Clock Adjustment" screen.

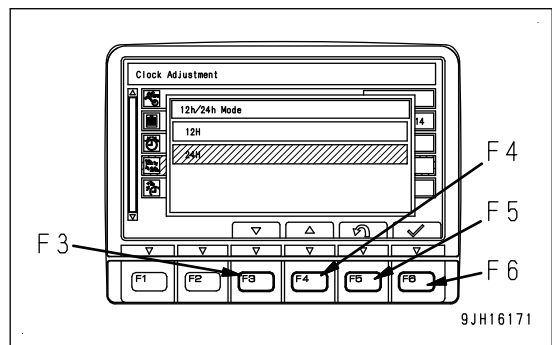

### DAYLIGHT SAVING TIME (SUMMER TIME) SETTING

If "Daylight Saving Time" is turned on, the clock display becomes 1 hour forward. If "Daylight Saving Time" is turned off, the clock display returns to the set time.

1. Select "Daylight Saving Time" (e) on "Clock Adjustment" screen, then press switch F6.

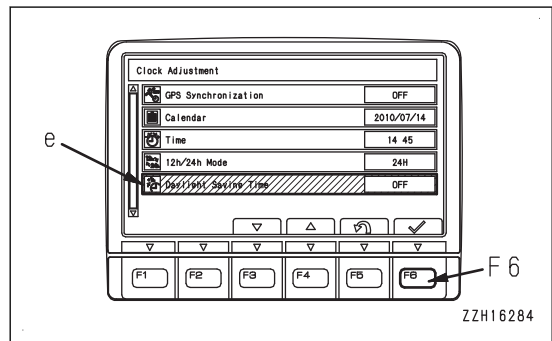

2. The "Daylight Saving Time" screen is displayed.
  - F3: Moves to the next item (1 line below). Moves to the top line when on the bottom line.
  - F4: Moves to the previous item (1 line above). Moves to the bottom line when on the top line.
  - F5: Cancels change and returns to "Clock Adjustment" screen.
  - F6: Accepts change and returns the screen to "Clock Adjustment" screen.

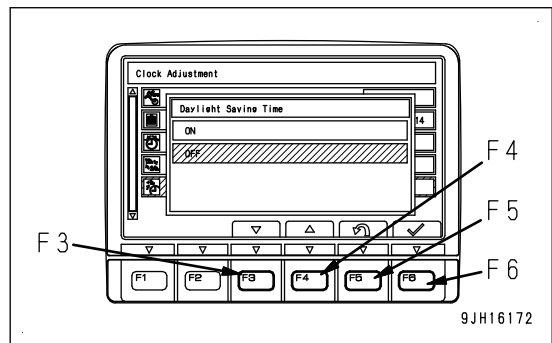

**REMARK**

Daylight saving time or summer time means moving the clock forward an hour to take advantage of the fact that the sun rises early in summer in our daily life.

## LANGUAGE SETTINGS

On “Language Setting” menu, it is possible to select the language used on the monitor display.

The languages that can be selected are as follows.

English, Japanese, French, Spanish, Portuguese, Italian, German, Swedish, Dutch, Danish, Norwegian, Finnish, Icelandic, Czech, Hungarian, Polish, Slovak, Slovene, Romanian, Croatian, Estonian, Latvian, Lithuanian, Bulgarian, Greek, Turkish, Serbian

1. Select “Language” (4) on “Monitor Setting” menu, then press switch F6.

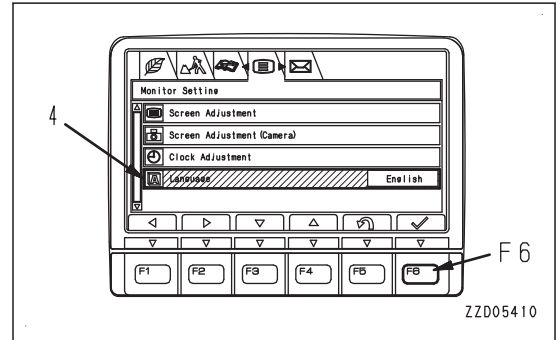

2. Select the language to use for the display, then press switch F6. The screen display changes to the selected language.

On “Language” screen, it is possible to perform the following operations with switches F3 to F6.

F3: Moves to the item below.

F4: Moves to the item above.

F5: Cancels change and returns to the “Monitor Setting” screen.

F6: Accepts change and returns the screen to the “Monitor Setting” screen.

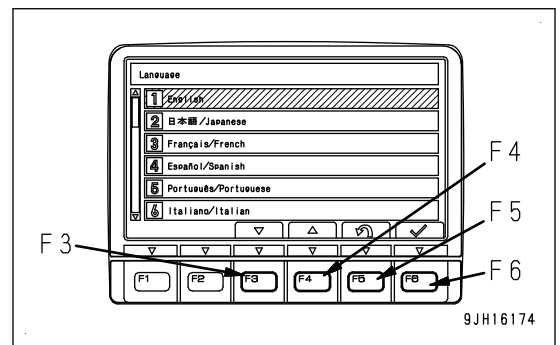

### OPERATOR ID

You can check and change the “Operator ID” which is under identification on the “Operator ID” menu.  
The “Operator ID” menu is not displayed when the operator identification function is disabled.

#### REMARK

Contact your Komatsu distributor for details of the method of setting, changing, or canceling the operator identification function.

### WHEN OPERATOR IDENTIFICATION FUNCTION IS AVAILABLE WITH SKIP

When the starting switch is ON and ID is inputted, the identified ID is displayed in the column of “Operator ID” on “Monitor Setting” menu screen.

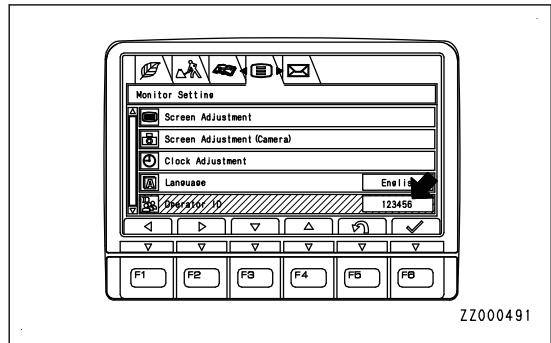

When the starting switch is ON and “SKIP” is selected, “\*\*\*\*” is displayed in the column of “Operator ID” on “Monitor Setting” menu screen.

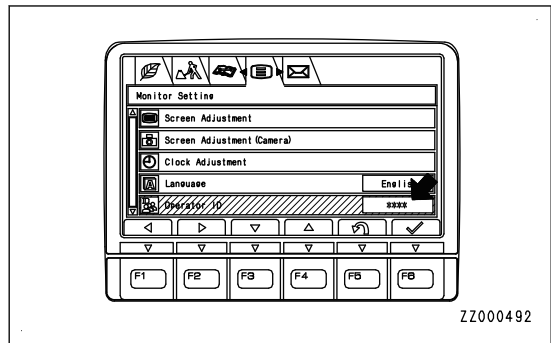

- 1. Select operator ID (5) on “Monitor Setting” menu screen, then press switch F6 for 1 second.

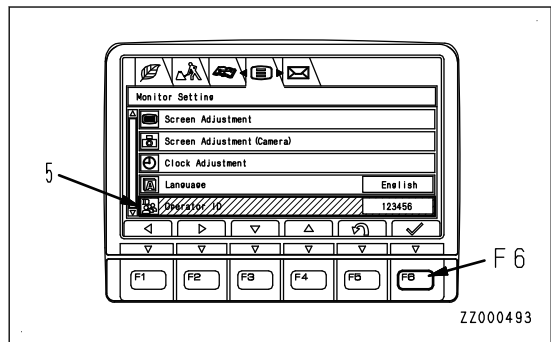

- 2. “Operator ID Change” screen is displayed.

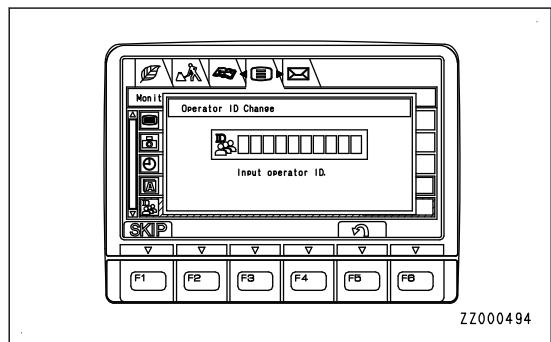

- Input the already registered ID on “Operator ID Change” screen and press F6. Then, the identified ID can be changed.

A message is displayed below and the screen returns to “Monitor Setting” menu screen.

On “Monitor Setting” menu screen, the inputted ID is displayed in the column of “Operator ID”.

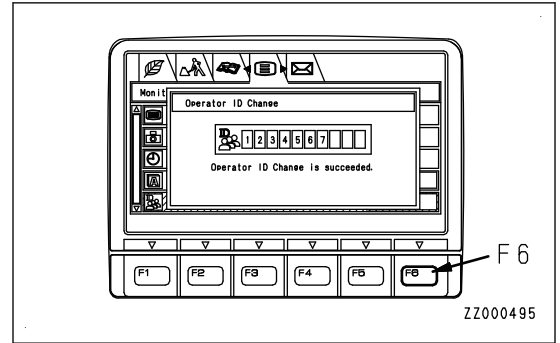

- When you press switch F1 on “Operator ID Change” screen, a message is displayed below and the screen returns to “Monitor Setting” menu screen.

On “Monitor Setting” menu screen, as the same way when the starting switch is ON and “SKIP” is selected, “\*\*\*\*” is displayed in the column of “Operator ID”.

In this case, “Operator ID” is not identified.

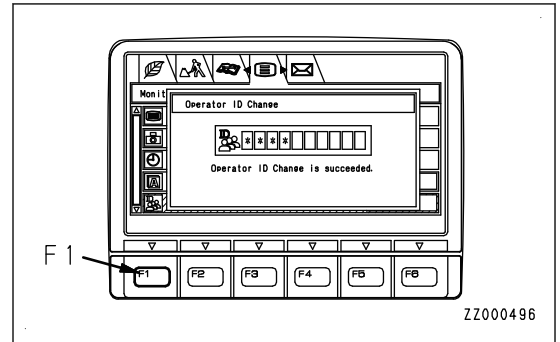

- When you press switch F6 after inputting the ID which is not registered to “Operator ID Change” screen, a message is displayed below and the screen returns to “Monitor Setting” menu screen.

In this case, the identified ID is not changed.

- On “Operator ID Change” screen, if no switch is operated for more than 30 seconds, the screen automatically changes to “Monitor Setting” menu screen. In this case, the identified ID is not changed.

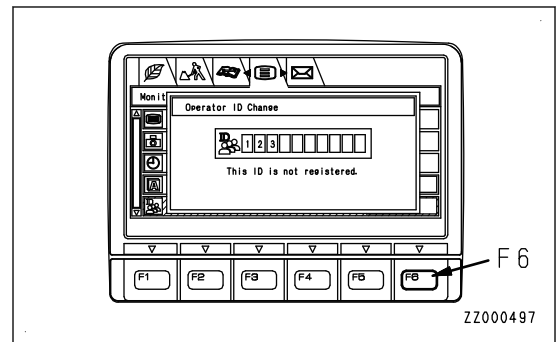

**WHEN OPERATOR IDENTIFICATION FUNCTION IS AVAILABLE WITHOUT SKIP**

When the operator identification function is available without SKIP, the identified ID number is not displayed in “Operator ID” column of “Monitor Setting” screen.

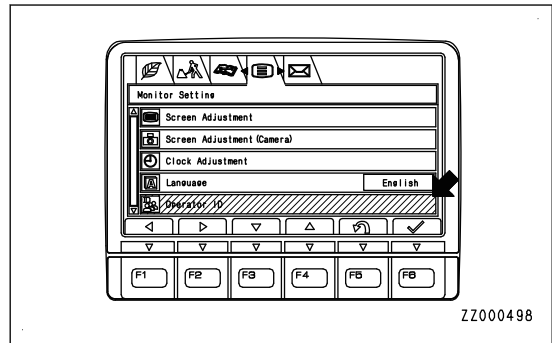

1. Select “Operator ID” (5) on “Monitor Setting” menu screen, then press switch F6 for 1 second.

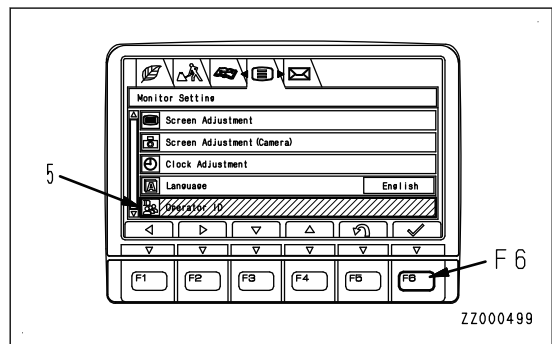

2. “Operator ID Change” screen is displayed.

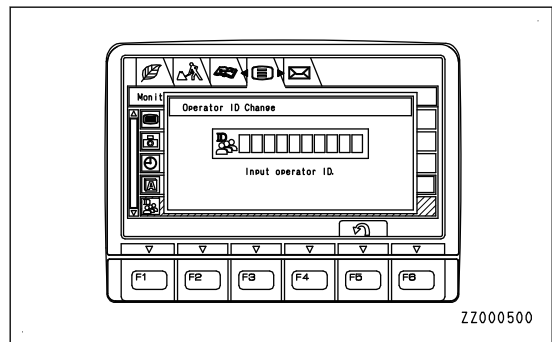

- Input the already registered ID on “Operator ID Change” screen and press F6. Then, the identified ID can be changed.

A message is displayed below and the screen returns to “Monitor Setting” menu screen.

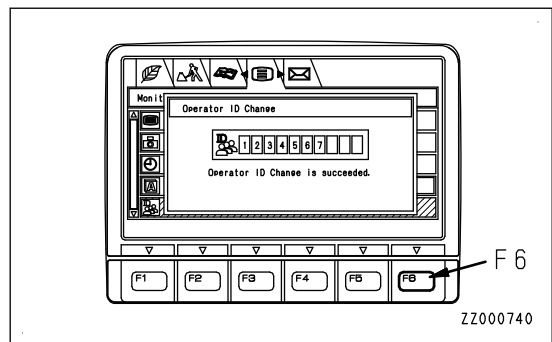

- When you press switch F6 after inputting the ID which is not registered to “Operator ID Change” screen, a message is displayed below and the screen returns to “Monitor Setting” menu screen.

In this case, the identified ID is not changed.

- On “Operator ID Change” screen, if no switch is operated for more than 30 seconds, the screen automatically changes to “Monitor Setting” menu screen. In this case, the identified ID is not changed.

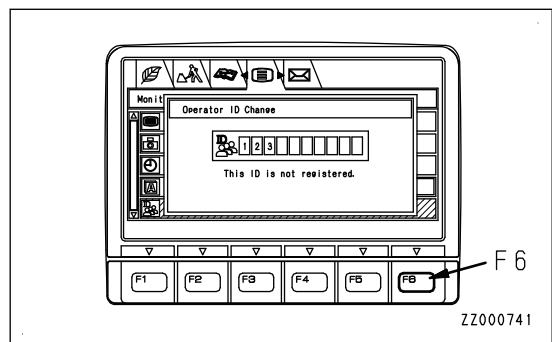

### MESSAGE DISPLAY

On machines equipped with KOMTRAX, you can see the messages from your Komatsu distributor on this menu (e). When there is any message, the message display of the standard screen lights up.

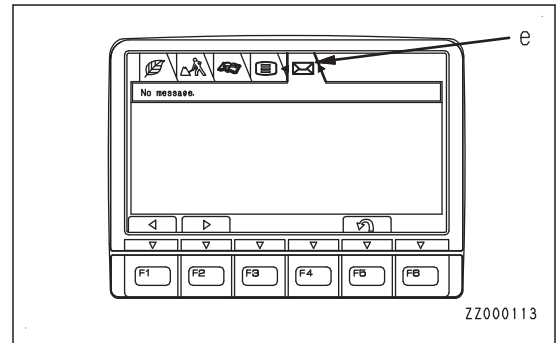

Message is distinguished as follows according to the lighting states of message display (1).

Lights up in green (A): There is unread message.

Lights up in blue (B): There is any read message to which no reply is made.

OFF: No messages

#### REMARK

- When the message display lights up in blue (B), it means that no reply has been made yet to any read message to your Komatsu distributor. Reply to the message in accordance with the replying method mentioned below:
- If the starting switch is turned to OFF position when there is any unread message, the message will be displayed on the end screen, and when the monitor is started next time, the message will change to a read message (the message display: lights up in blue (B)).
- The message will be deleted when it becomes out of date or when a new message reaches.

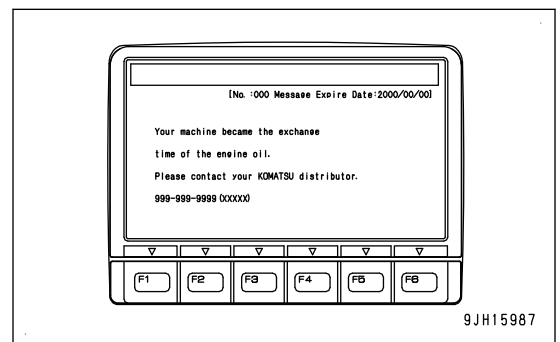
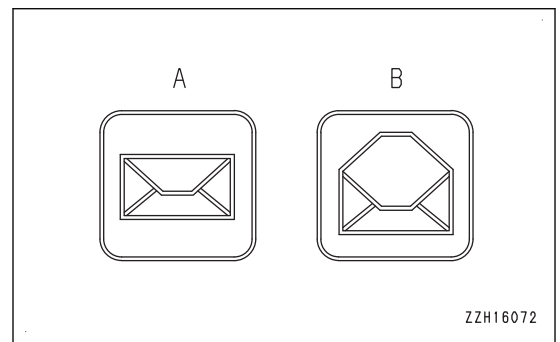
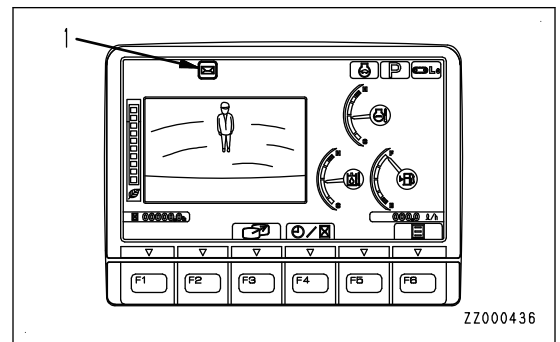

### CHECK MESSAGE

- On the standard screen, press switch F6.  
 When there is any message, message display (1) lights up.  
 While message display (1) is lit, press switch F6, and mail confirmation menu (e) directly opens.
- Select mail confirmation menu (e), and you can read the arrived message.
- If a message requests reply, the "Numeric Input: []" box (2) is displayed at (e) of the mail confirmation menu. Make a reply to the message.

**REMARK**

- (3) is the subject of the received message. When no message is received, "No message" is displayed in place (3).
- (4) is the serial number of received messages.

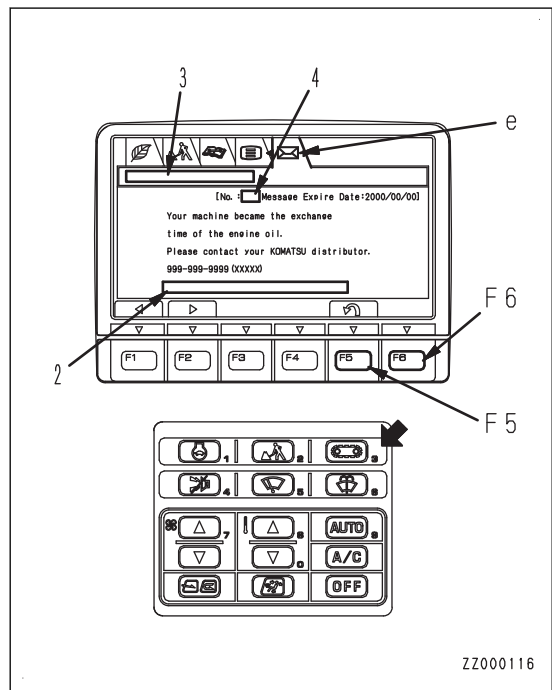
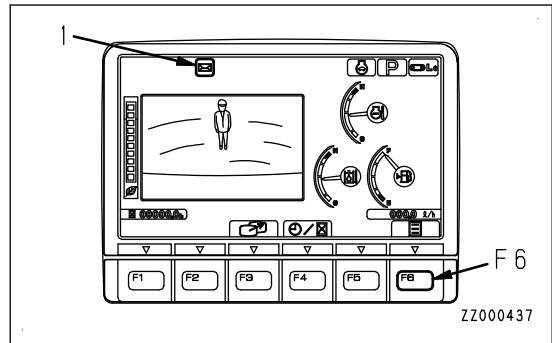

### REPLY TO MESSAGE

- When replying to a message, input the selected item number in "Numeric Input: []" box (2) on the screen of mail confirmation menu (e). The selected item number is written in place (5) of the message text.
  - Input the number by using the monitor panel switch. Each switch corresponds to the value shown on the right side below the switch.
  - If you input an incorrect number, press switch F5, and you can clear an input character at a time.
  - If switch F5 is pressed when the input column is blank, the screen returns to the standard screen.
- After inputting a selected item number, press switch F6.
- When the message "Do you send Numeric Input?" is displayed in the column (2) of the mail confirmation menu screen, press switch F6 again. The input value will be sent out.  
 When the message "Do you send Numeric Input?" is displayed, if you press switch F5, the screen returns to the screen for replying to message. At this time, the previous input value will be cleared.

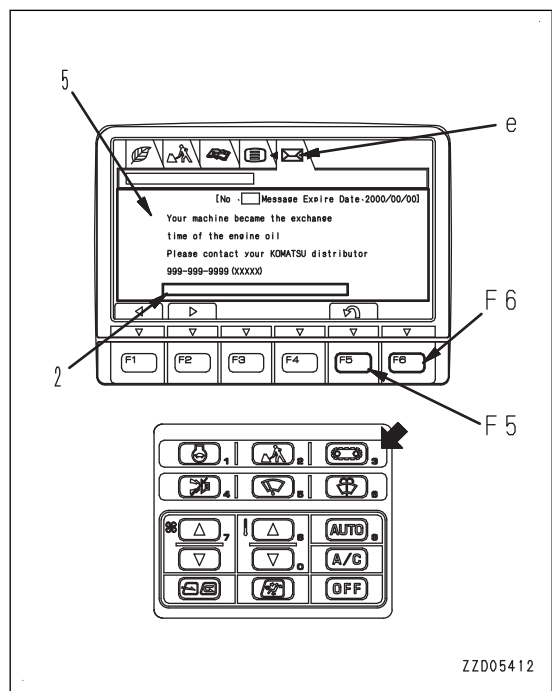

**SWITCHES**

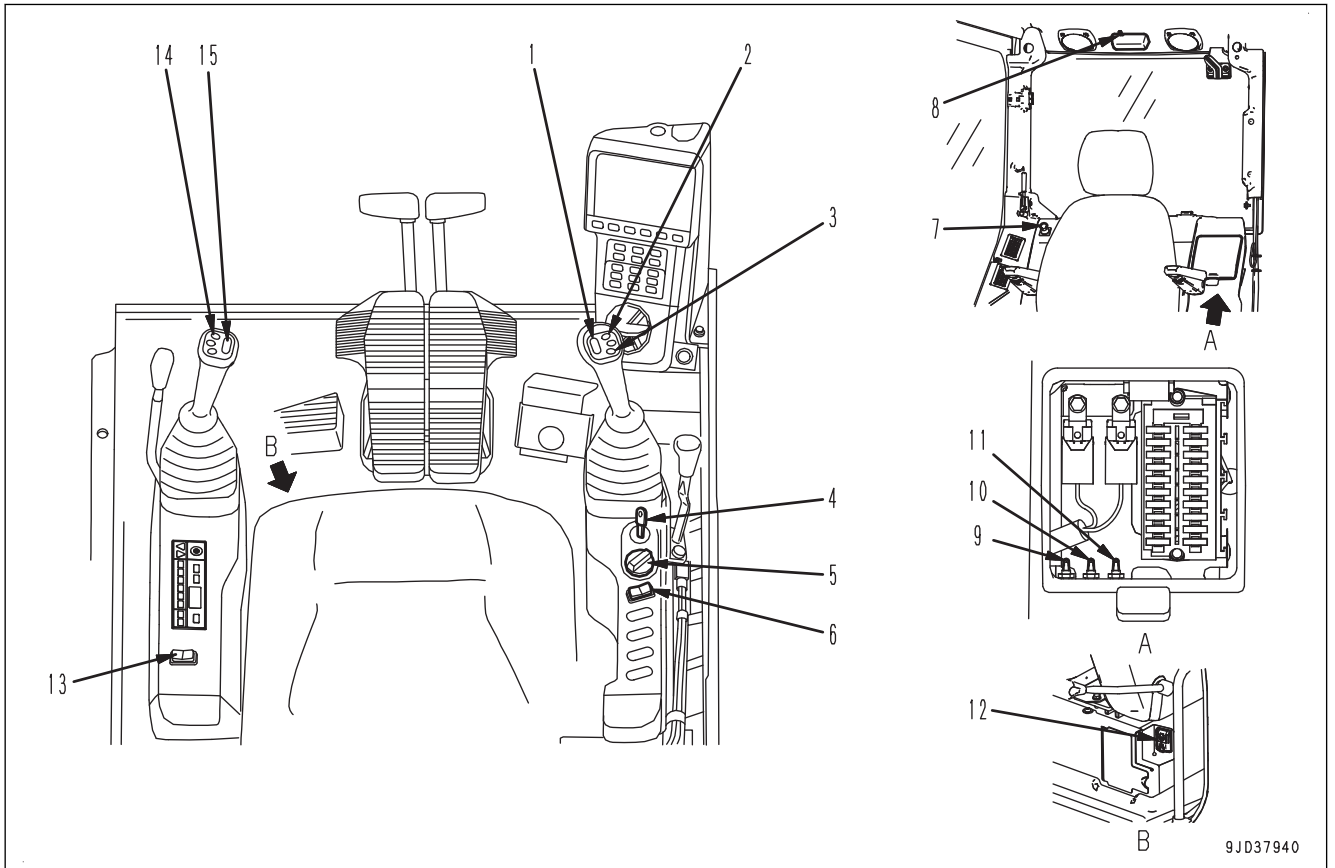

- (1) 1st-line attachment proportional switch
- (2) Breaker control switch
- (3) Horn switch
- (4) Starting switch
- (5) Fuel control dial
- (6) Lamp switch
- (7) Cigarette lighter
- (8) Room lamp switch

- (9) Pump secondary drive switch
- (10) Swing parking brake cancel switch
- (11) Lock lever automatic lock cancel switch
- (12) Engine shutdown secondary switch
- (13) Quick coupler main switch
- (14) Quick coupler operation switch
- (15) 2nd-line attachment proportional switch



**STARTING SWITCH**

Starting switch is used to start or stop the engine.

**(A): OFF position**

The key can be inserted or withdrawn. Switches for the electrical system (except room lamp) are all turned off, and the engine is stopped.

**(B): ON position**

Electric current flows through the charging and lamp circuits. Keep the starting switch key at this position while the engine is running.

**(C): START position**

This is the position to start the engine. Keep the key at this position during cranking.

The key will return to ON position (B).

**(D): HEAT (preheating) position**

When starting in cold weather, turn the key to this position.

When the key is turned to HEAT (preheating) position (D), the HEAT pilot lamp lights up. Keep the key at this position until the HEAT pilot lamp flashes. Release the key immediately after the HEAT pilot lamp flashes. When you release the key, it returns to OFF position (A). Start the engine immediately by turning the key to START position (C).

**REMARK**

If the lock lever is not at LOCK position (L), the engine does not start.

Check that the lock lever is at LOCK position (L) when operating the starting switch.

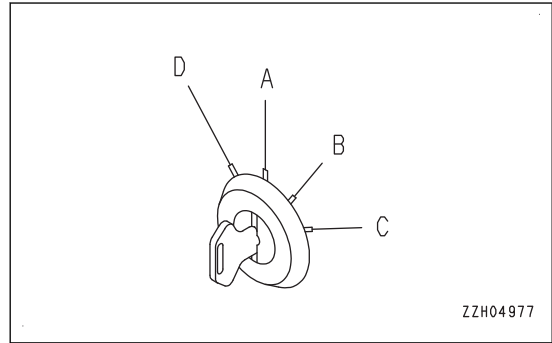

ZZH04977

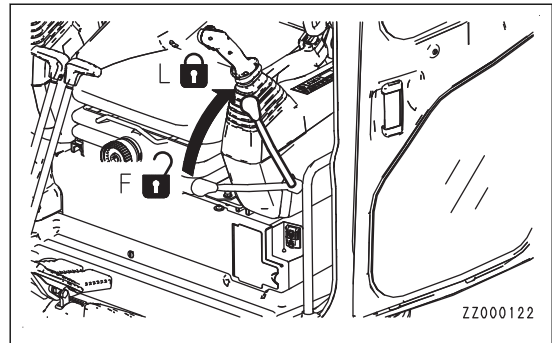

ZZ000122

**FUEL CONTROL DIAL**

Fuel control dial is used to control the engine speed and output.

**(a) Low idle (MIN)**

The position where turning the dial fully to the left.

**(b) High idle (MAX)**

The position where turning the dial fully to the right.

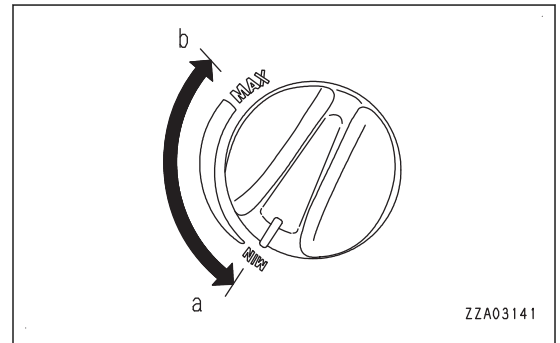

ZZA03141

**REMARK**

This machine controls the main pump for the best matching by controlling the engine electronically. The dial has a dead zone but it is not abnormal.

**Range (c)**

Dead zone (engine speed is constant)

P mode: 22%

E mode: 30%

**Position (d)**

High idle

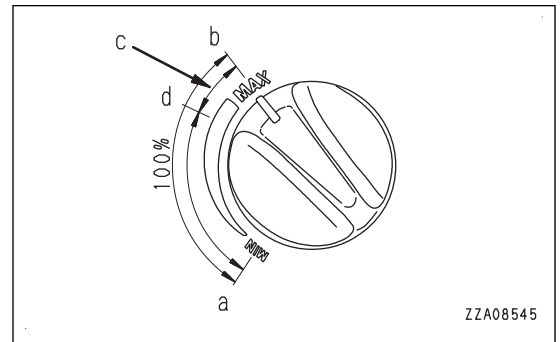

ZZA08545

**CIGARETTE LIGHTER**

The cigarette lighter is used to light cigarettes.

When the cigarette lighter is pushed in, it will return to its original position after several seconds, so pull it out to use it.

If the cigarette lighter is removed, the socket can be used as an 85 W (24 V x 3.5 A) power source.

**NOTICE**

**This cigarette lighter is for 24 V. Do not use as a power supply for 12 V equipment.**

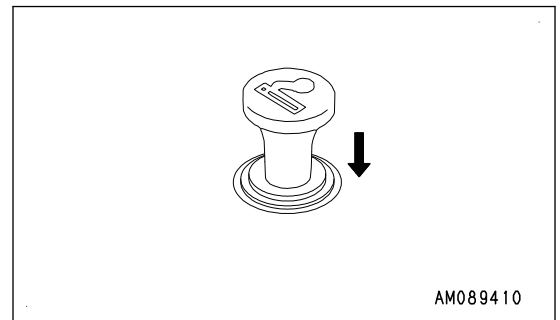

AM089410

**1ST-LINE ATTACHMENT PROPORTIONAL SWITCH**

Operate the 1st-line attachment proportional switch when using general attachments.

You can increase or decrease the flow rate by controlling the switch stroke.

The attachment does not operate unless the attachment mode is set on the machine monitor.

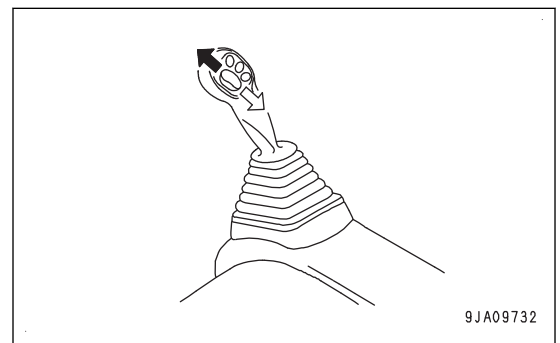

9JA09732

### 2ND-LINE ATTACHMENT PROPORTIONAL SWITCH

Proportional control rolling switch.

The 2nd-line attachment proportional switch operates the 2nd attachment circuit (e.g. clamshell rotation). The 2nd-line attachment proportional switch is a roller proportional control switch. Rolling the switch up produces rotation in one direction, rolling down produces rotation in the opposite direction. Slight movement of the roller will give slight movement of the clamshell; full movement of the roller will give faster movement of the clamshell.

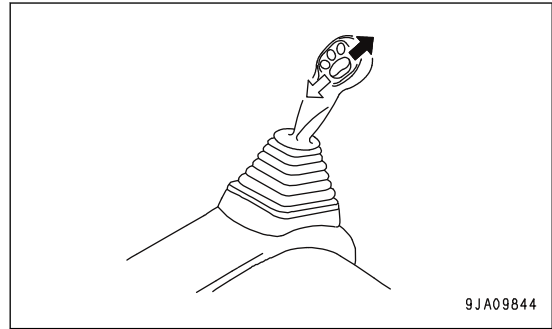

### BREAKER OPERATION SWITCH

The breaker control switch is used to operate the breaker.

For handling of the breaker control switch, see "HANDLE MACHINE READY FOR INSTALLATION OF ATTACHMENT".

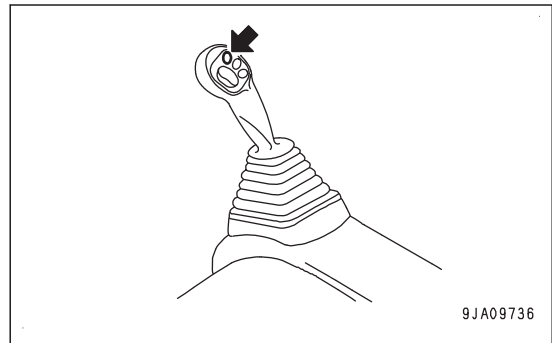

### LAMP SWITCH

Lamp switch is used to light up the working lamp and monitor illumination.

#### (a) Night position

Lamps light up and monitor illumination is set to night mode.

#### (b) Day position

Lamps light up and monitor illumination is set to day mode.

#### (c) OFF position

Lamps go out.

(The monitor illumination is set to day mode.)

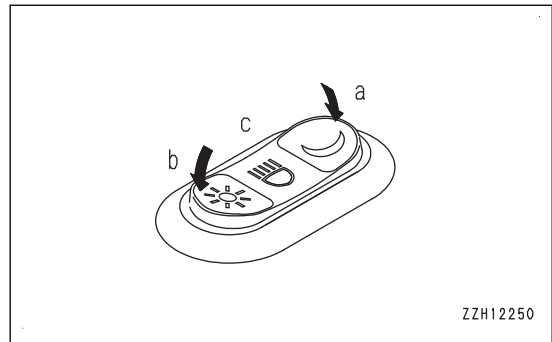

### HORN SWITCH

The horn switch is used to sound the horn.

Press the horn switch on the R.H. work equipment control lever, and the horn sounds.

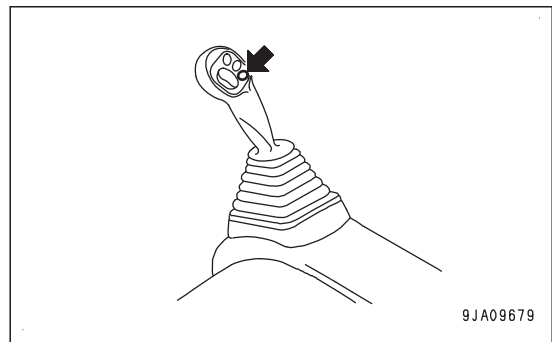

## ROOM LAMP SWITCH

### NOTICE

If the room lamp is left to be turned on, the batteries may be exhausted. Always turn the switch to OFF position after using room lamp.

Use room lamp switch to light up the room lamp.

#### (a) ON position

Lights up

#### (b) OFF position

OFF

The room lamp lights up even when the starting switch is at OFF position.

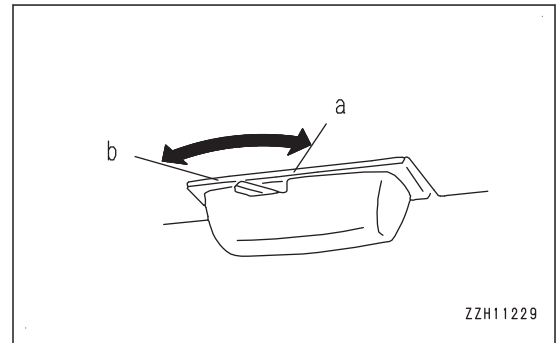

## PUMP SECONDARY DRIVE SWITCH

### NOTICE

- The pump secondary drive switch enables you to operate the work equipment or the machine temporarily when any problem occurs on the pump control system. Do not use it except for emergency. Repair the problem as soon as possible.
- If this switch is moved to emergency position by mistake while the machine is operating normally, "L03" is shown in the machine monitor.  
If "L03" is displayed during the work, check that the switch is in normal position.

The pump secondary drive switch is used to make it possible to operate the work equipment or the machine temporarily if any problem should occur in the pump control system (when the machine monitor shows "L03").

#### (a) Emergency

When abnormal (switch is set back)

#### (b) Normal

When normal (switch is set forth)

If the machine monitor shows "L03", set this switch to emergency position (a) to make it possible to perform operations.

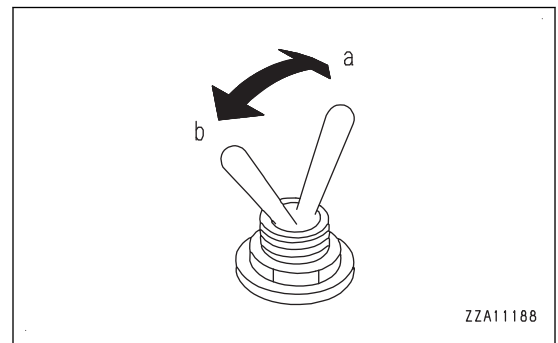

### SWING PARKING BRAKE CANCEL SWITCH

**NOTICE**

Swing operations can be performed temporarily with swing parking brake cancel switch when there is a problem in the swing parking brake system. Do not use it except for emergency. Repair the problem as soon as possible.

Swing operations can be performed temporarily with swing parking brake cancel switch when there is a problem in the swing parking brake system (when the upper structure does not swing but the machine monitor does not show “L03”).

**(a) Cancel**

When abnormal (switch is set back)

**(b) Normal**

When normal (switch is set forth)

When the upper structure does not swing but the machine monitor does not show “L03”, move this switch to cancel position (a), and operation can be performed.

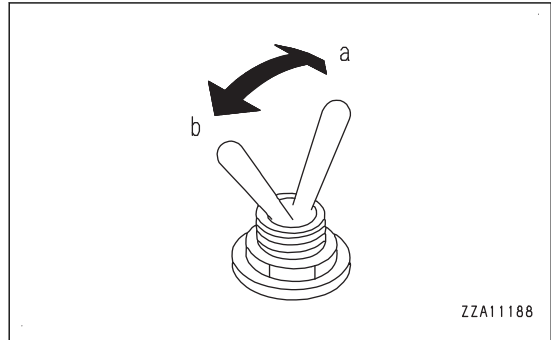

ZZA11188

### LOCK LEVER AUTOMATIC LOCK CANCEL SWITCH

**NOTICE**

The lock lever automatic lock cancel switch is used to disable the lock lever automatic lock function and enable the operations of the work equipment and machine temporarily, when the lock lever automatic lock function is abnormal. Use this switch only when the machine or working machine needs to be moved temporarily in an abnormal and emergency condition. Repair the problem as soon as possible.

The lock lever automatic lock cancel switch is used to disable the lock lever automatic lock function and enable the operations of the work equipment and machine temporarily, when the lock lever automatic lock function is abnormal (when the lock lever automatic lock function still works even if the lock lever is canceled normally while the work equipment control lever or travel lever is in neutral).

**(a) Cancel**

When in abnormal and emergency condition (switch is set back)

**(b) Normal**

When normal (switch is set forth)

- When the lock lever automatic lock cancel switch is set to cancel position (a), the lock lever automatic lock cancel pilot lamp lights up. At the same time, the mode is displayed in the center of the monitor display, and after 2 seconds, the screen returns to the standard screen.
- After moving the machine or work equipment temporarily by operating this switch, stop the engine, return the switch to normal position (b), and then ask your Komatsu distributor for repair.

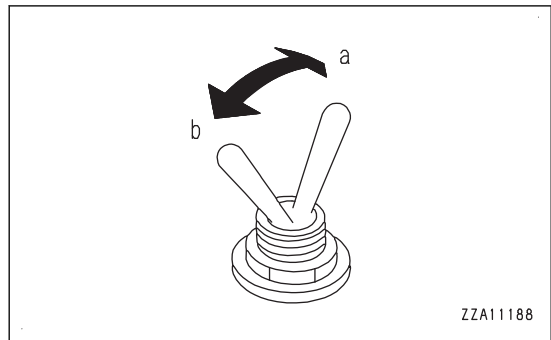

ZZA11188

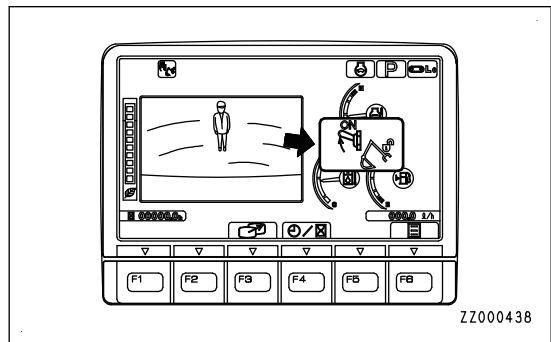

ZZ000438

## ENGINE SHUTDOWN SECONDARY SWITCH

### NOTICE

The engine shutdown secondary switch is used to stop the engine when the starting switch is turned to OFF position but the engine does not stop.

- Use the engine shutdown secondary switch only in an emergency.  
Contact your Komatsu distributor for repair immediately when there is any abnormality on this switch.
- If the engine shutdown secondary switch is moved to engine stop position by mistake while the machine is operating normally, “Engine Shutdown Secondary SW in Operation” is displayed on the machine monitor.  
If “Engine Shutdown Secondary SW in Operation” is displayed on the machine monitor, check that the switch cover is closed and the switch is in normal mode position. If not, set it to normal mode position.

1. Raise cover (C) to open it.

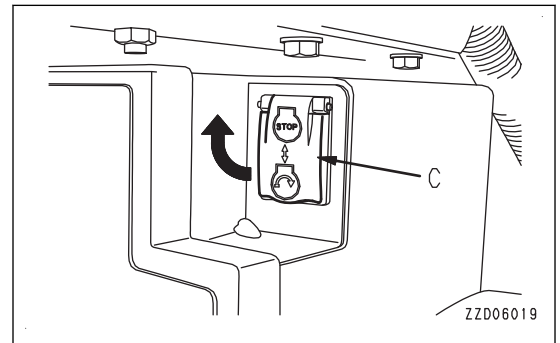

2. Turn the engine shutdown secondary switch to upper position (a) and the engine stops.

**(a) Engine stop**

When abnormal (switch is set to upper position)

**(b) Normal mode**

When normal (switch is set to lower position)

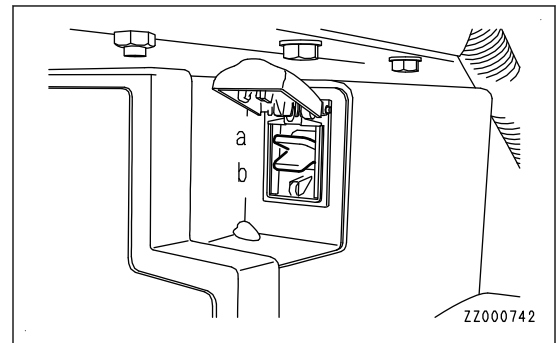

- When cover (C) is closed, the engine shutdown secondary switch automatically returns to normal position (b).
- When the starting switch is turned to ON position while the engine shutdown secondary switch is in the engine stop position (a), “Engine Shutdown Secondary SW in Operation” is displayed on the machine monitor.

If this screen is displayed, return the engine shutdown secondary switch to normal position (b).

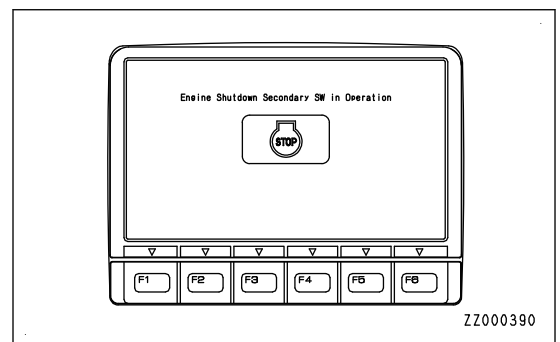

## QUICK COUPLER SWITCH

The switch (1) on the L.H. console and the switch (2) on the L.H. work equipment control lever are the switches to operate the quick coupler.

For details, see "HANDLE QUICK COUPLER".

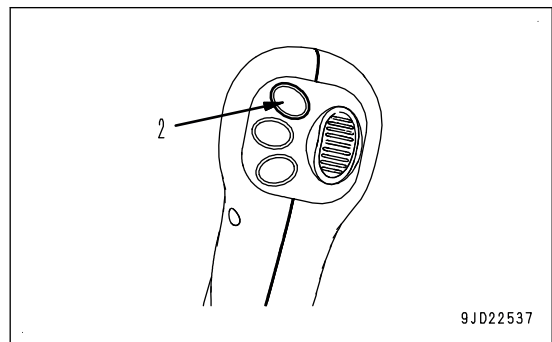
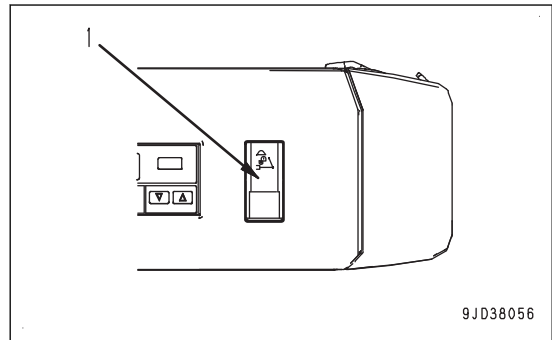

## CONTROL LEVERS AND PEDALS

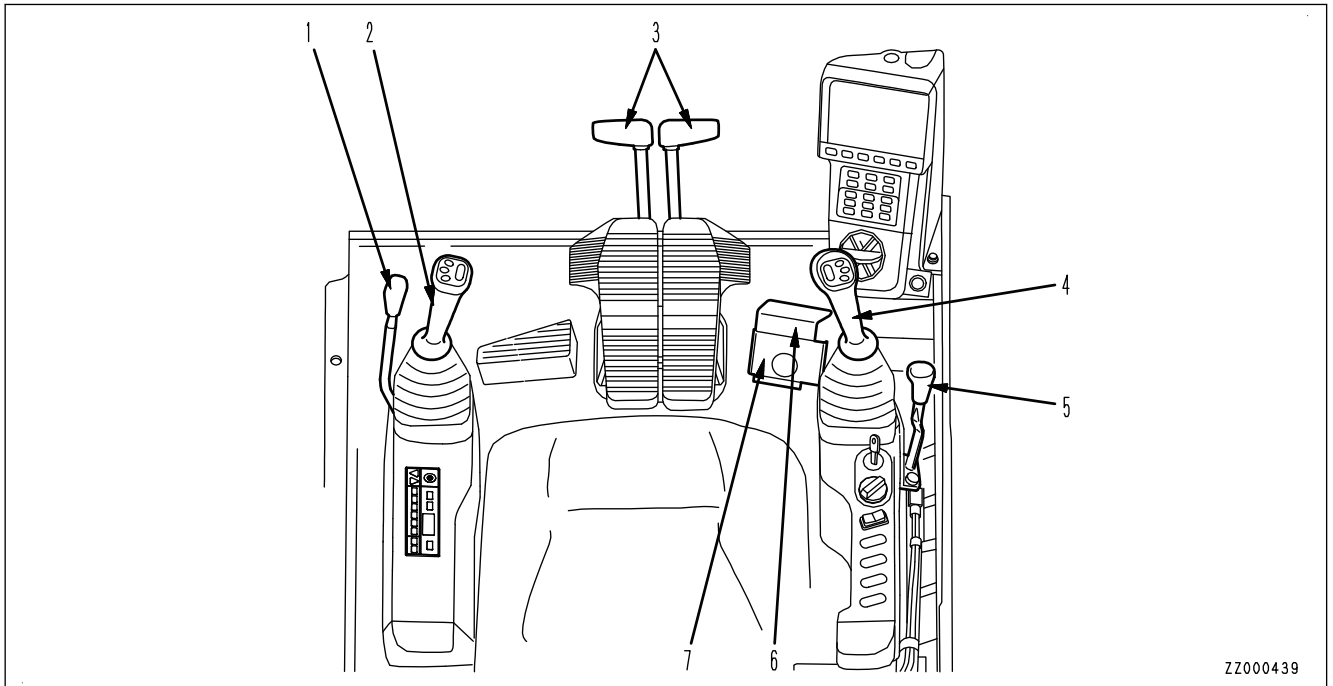

ZZ000439

- |   |  |
|---|--|
| (1) Lock lever  | (5) Blade control lever (with auto-deceleration system)      |
| (2) L.H. work equipment control lever (with auto-deceleration system) | (6) Swing lock cover   |
| (3) Travel lever (with pedal and auto-deceleration system)            | (7) Boom swing control pedal (with auto-deceleration system) |
| (4) R.H. work equipment control lever (with auto-deceleration system) |  |

## LOCK LEVER

### ⚠ WARNING

- When leaving the operator's seat, set the lock lever securely to **LOCK** position. If the lock lever is not at **LOCK** position and the control levers or control switches are touched by mistake, it may lead to serious personal injury or death.
- Always check that the lock lever is in **LOCK** position.
- When pulling the lock lever up, or when pushing the lock lever down, be careful not to touch the work equipment control lever.
- Before setting the lock lever to **FREE** position, make sure that all levers and pedals are set to **NEUTRAL** position. If any of them is out of **NEUTRAL** position, the work equipment or machine may move suddenly and cause a serious personal injury or death.

The lock lever is a device to lock the work equipment, swing, travel, and attachment control levers.

### (L) LOCK position:

Even if a control lever or an attachment control switch is operated, machine does not move.

### (F) FREE position:

The operator can operate the machine by operating the control levers and attachment control switches.

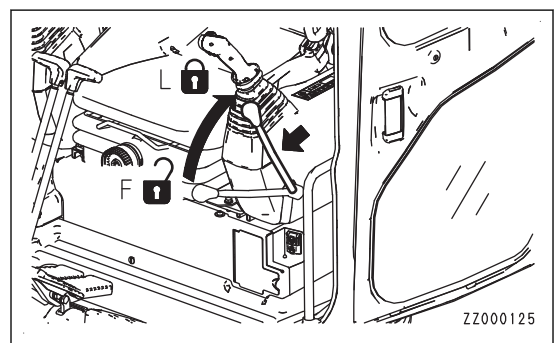

ZZ000125



When the lock lever is set to LOCK (L) position, the work equipment lock pilot lamp lights up. At the same time, the mode is displayed in the center of the monitor display, and after 2 seconds, the screen returns to the standard screen.

**REMARK**

The lock lever is of hydraulic lock type. Accordingly, when it is in LOCK position (L), the control levers and control switches move but the machine does not move.

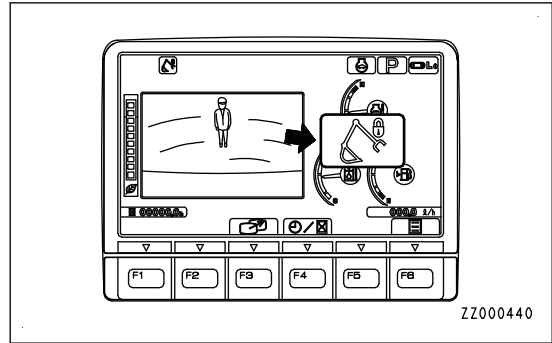

**Automatic lock function of lock lever**

**! WARNING**

- The lock lever automatic lock function assists the operator in judgment to reduce damage caused by accident. It does not stop the work equipment or machine in all situations.
- Even if the lock lever automatic lock function works, the work equipment or machine may not stop immediately or may stop after moving by a certain distance. Also, the lock lever automatic lock function may not work in the following cases. Accordingly, do not rely on it too much.
  - When the hydraulic oil temperature is low (When the hydraulic oil temperature caution lamp indicates low temperature)
  - When the viscosity of the hydraulic oil used is higher than that of the genuine hydraulic oils which Komatsu recommends
  - When system has failure
- Before setting the lock lever to FREE position, make sure that all levers and pedals are set to NEUTRAL position. If any of them is out of NEUTRAL position, the work equipment or machine may move suddenly and cause a serious personal injury or death.

The lock lever automatic lock function automatically sets the lock lever in the locked state to prevent the work equipment or machine from operating continuously when the lock lever is released while the work equipment control lever or travel lever is operated.

When this function works, the operations of the work equipment, swing, travel, and attachment are locked automatically and the message shown in the figure is displayed.

While this function is in operation, the machine does not move even if a control lever or the attachment control switch is operated while the lock lever is in FREE position (F).

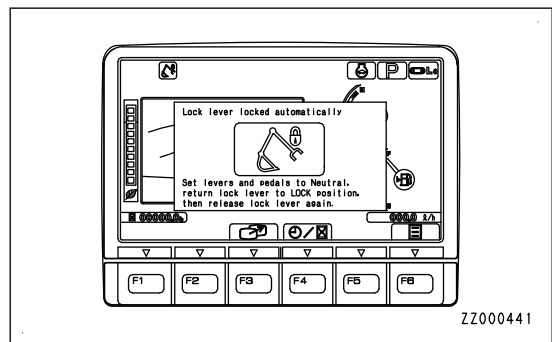

To cancel the lock, return the lock lever to LOCK position (L), check that each control lever and the attachment switch are in neutral, and then release the lock lever again.

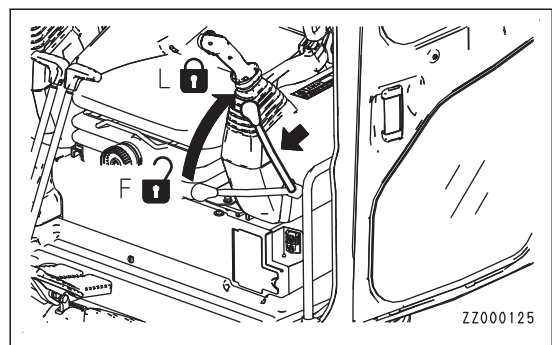

**TRAVEL LEVER**

**⚠ WARNING**

- If you perform operations with your foot on the pedal, the machine may suddenly start if you depress the pedal by mistake, and this may lead to serious personal injury or death. Be extremely careful when using the pedal for travel and steering operations, and do not put your foot on the pedal when it is not necessary.
- When the track frame is facing the rear, the direction of operation of the steering lever is the opposite to the direction of movement of the machine (forward/reverse, right/left turn).  
When operating the travel lever, always check if the track frame is facing the front or the rear. (When the sprocket (A) is at the rear, the track frame is facing the front.)

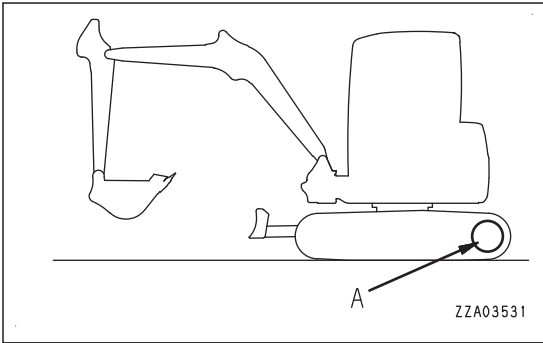

The travel lever is used to change the direction of travel between forward and reverse. ( ) shows the pedal operation.

**(a) FORWARD**

The lever is pushed forward.  
(Depress the front side of pedal.)

**(b) REVERSE**

The lever is pulled back.  
(Depress the rear side of pedal.)

**N (NEUTRAL)**

The machine stops.

**REMARK**

If the lever is shifted to FORWARD or REVERSE position from NEUTRAL position, the alarm sounds to warn that the machine is starting to move.

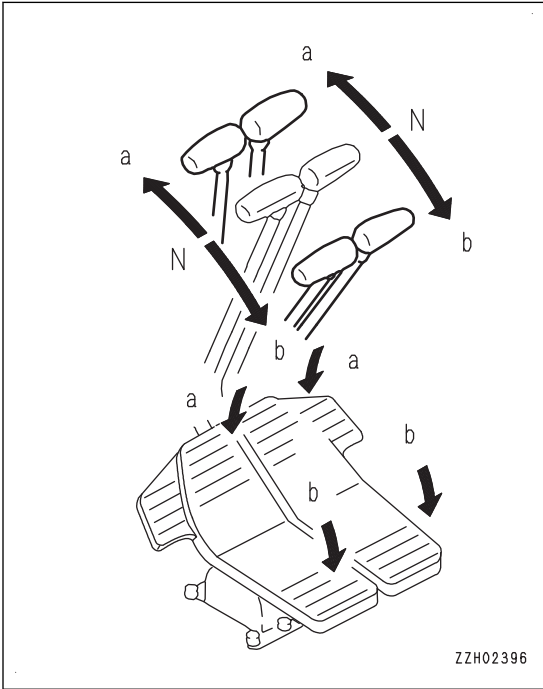

**BLADE CONTROL LEVER**

The blade control lever is used to control the blade.

(a): LOWER

(b): RAISE

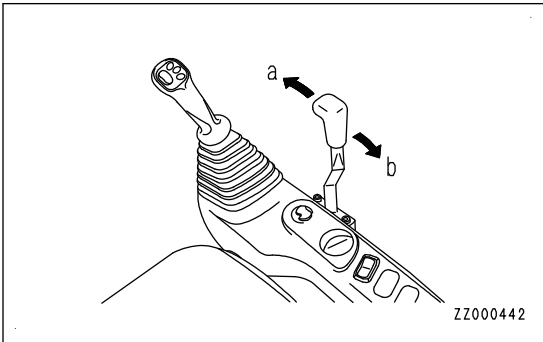

### SWING LOCK COVER

**! WARNING**

When you do not swing the boom, lock the swing operation with the swing lock cover. If it is not locked and the control pedal is touched by mistake, this may cause a serious injury or death.

The swing lock cover is used to lock the boom swing control pedal.

The pedal is locked by covering it with the plate.

(L): LOCK

(F): FREE

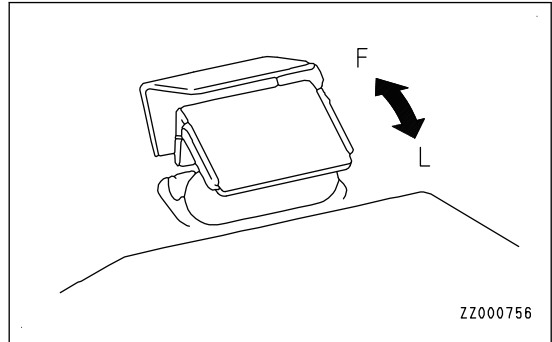

### BOOM SWING CONTROL PEDAL

**! WARNING**

When a bucket wider than the standard bucket is installed, if the upper structure is swung to the left with the work equipment pulled in, the bucket interferes with the cab and can cause a serious personal injury or death. Operate slowly, while checking the distance between the bucket and cab.

Swing the boom to the right or left by using the boom swing control pedal.

(a): Swing RIGHT

(b): Swing LEFT

N (NEUTRAL): Boom is held at current position.

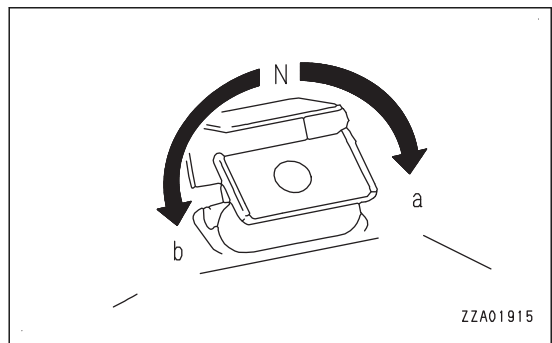

## WORK EQUIPMENT CONTROL LEVER

### WARNING

- The control pattern is set to the standard control method (ISO pattern).
- If it is necessary to change the control pattern, ask your Komatsu distributor.
- The operations in the control patterns other than the ISO pattern are explained in "Attachments and options". Be sure to read and understand them before starting the operation.
- When changing the control pattern, replace the control pattern plate with one matching the operation of the machine as well.  
The control pattern plate is stuck to the right side of the operator's seat.

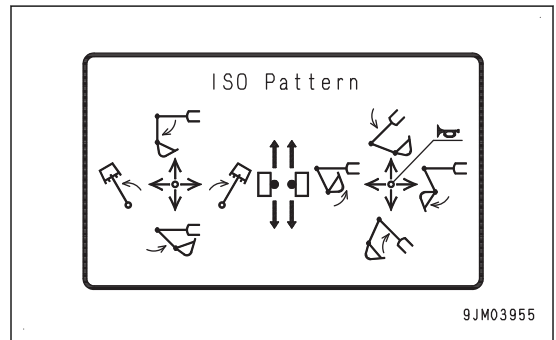
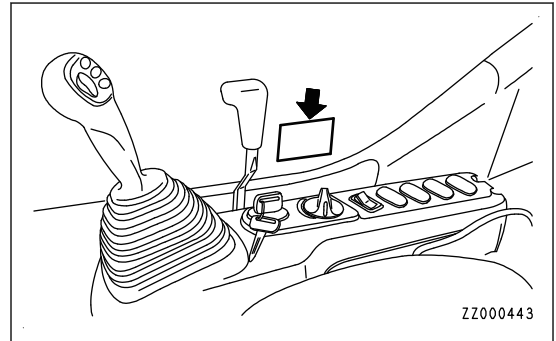

The left work equipment control lever is used to operate the arm and upper structure.

### Swing control

(a): Swing RIGHT

(b): Swing LEFT

### Arm control

(c): Arm IN

(d): Arm OUT

### N (NEUTRAL)

The upper structure and arm are held in position and do not move.

The right work equipment control lever is used to operate the boom and bucket.

### Boom control

(e): Boom RAISE

(f): Boom LOWER

### Bucket control

(g): Bucket DUMP

(h): Bucket CURL

### N (NEUTRAL)

The boom and bucket are held in position and do not move.

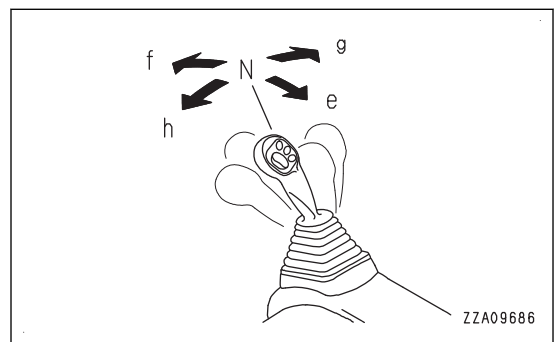
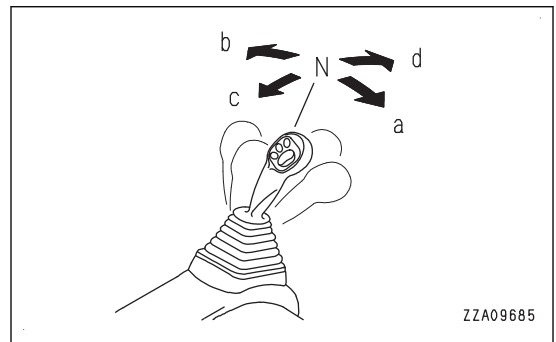

## OTHER EQUIPMENT

### METHOD FOR OPENING AND CLOSING CEILING WINDOW

#### **! WARNING**

When leaving the operator's seat, set the lock lever securely to LOCK position.

If the lock lever is at FREE position and the control lever, control pedal, or control switch is touched by mistake, it is dangerous and may cause serious personal injury or death.

#### When opening

1. Set the lock lever securely to LOCK position (L).

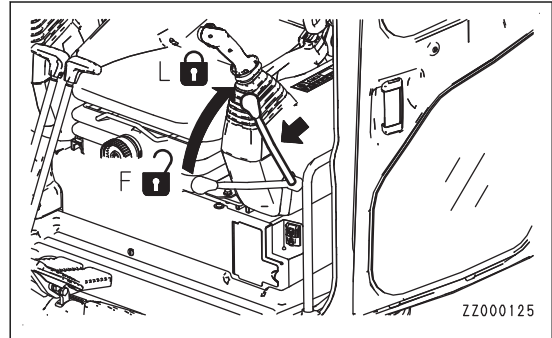

2. Push up lock (A) in the front center of the ceiling window and check that the lock is released. Then hold grip (B) and push up the ceiling window.

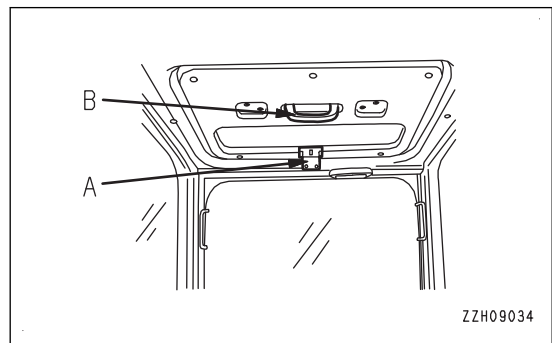

#### When closing

Hold grip (B), lower the ceiling window, and apply lock (A). If the lock cannot be applied, "open" the ceiling window, then pull it in again and apply the lock.

### METHOD FOR OPENING AND CLOSING CAB FRONT WINDOW

#### **! WARNING**

- When opening or closing the front window, bottom window, or door, always set the lock lever to LOCK position.  
If the lock lever is at FREE position and the control lever, control pedal, or control switch is touched by mistake, it is dangerous and may cause serious personal injury or death.
- When opening or closing the front window, stop the machine on a level ground, lower the work equipment to the ground, stop the engine, then perform the operation.
- When opening the front window, hold the handle securely with both hands to pull up, and do not release your hands until the front window is locked by the automatic lock catch.
- When closing the front window, the window may move quicker under its own weight. Hold the handles securely with both hands when closing it.

It is possible to stow the front window (upper side) in the roof of the operator's compartment.

**When opening**

1. Stop the machine on a level ground, lower the work equipment to the ground, then stop the engine.
2. Set the lock lever securely to LOCK position (L).

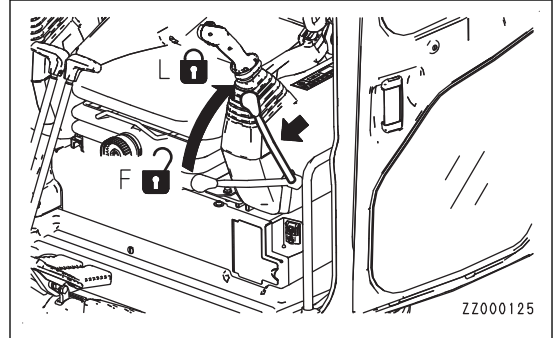

3. Check that the wiper blade is stowed in the right stay. If the wiper blade is stowed in wrong stowing position (b), lift it to move to the correct stowing position (a), or ask your Komatsu distributor for repair.

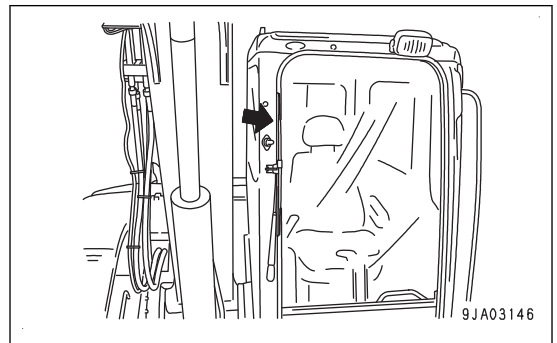

- (a) Correct stowing position  
The wiper blade is on the cab.
- (b) Wrong stowing position  
The wiper blade is on the glass.

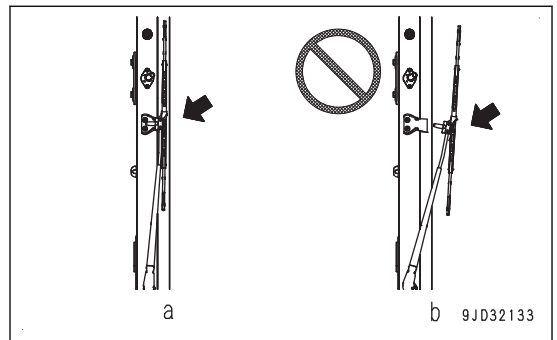

4. Hold two handles (A) on the right and left top sides of the front window, and pull two levers (B) to release the locks at the top of the front window. The top of the front window will come out.

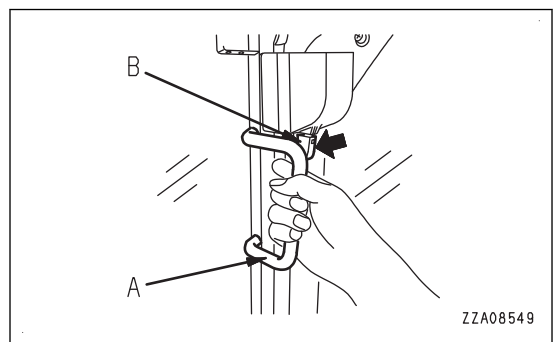
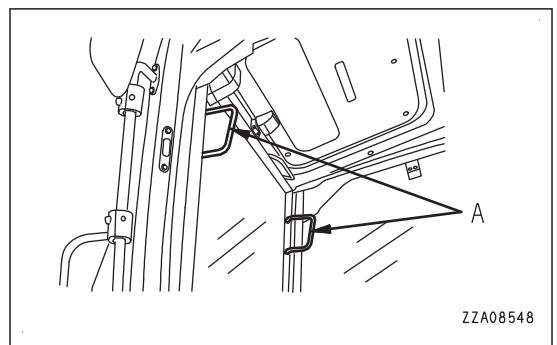

- 5. Hold lower handle (C) with your left hand from inside the operator's cab, and with your right hand, grip top handle (D), pull it up, and push it against lock catch (E) at the rear of the cab securely to lock the window.

**REMARK**

You may not use the two grips (A) on the left and right top sides of the front window to pull up the front window. Do not pull up the front window with the handles (A).

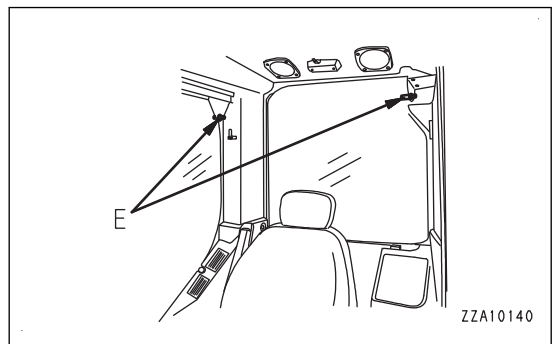
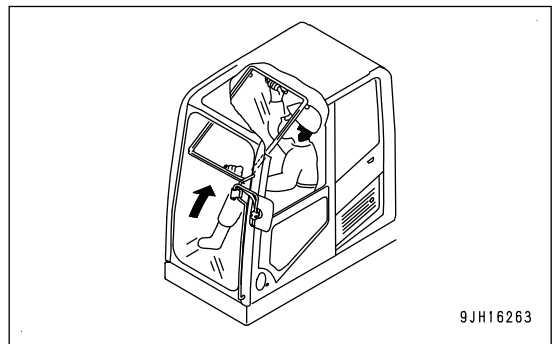
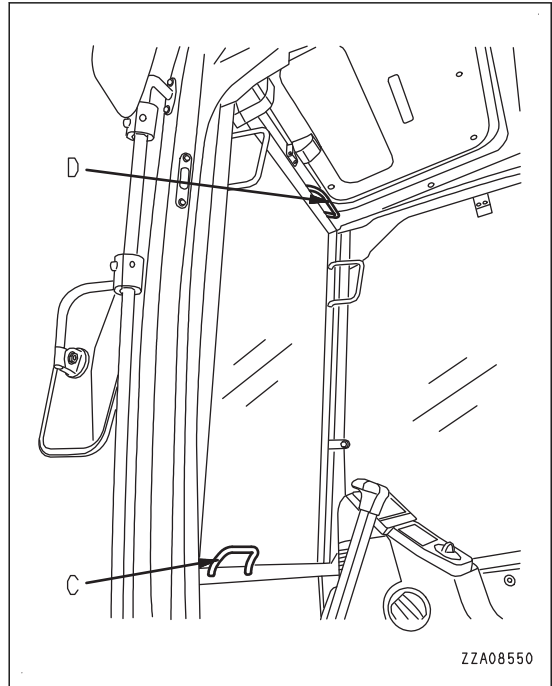

- 6. Check that lever (B) is securely at LOCK position.
  - If the arrow on lock case (F) matches the position of the arrow on lever (B), the lock is engaged. Check visually.
  - If the arrow on lock case (F) does not match the position of the arrow on lever (B), the lock is not engaged. Repeat the operation in step 5 to engage the lock.

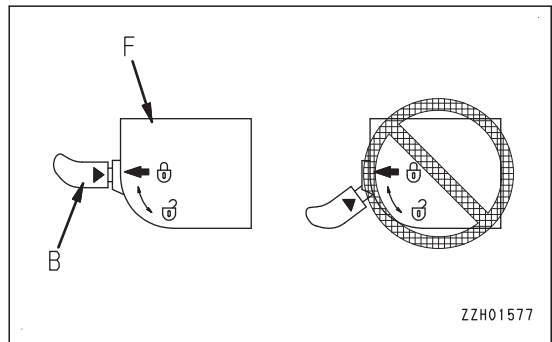

**When closing**

**⚠ CAUTION**

**When closing the window, lower it slowly and be careful not to get your hand caught.**

**NOTICE**

**Check that the wiper blade is stowed at the correct position (a), and close the front window. If the front window is closed when the wiper blade is being stowed at the wrong position (b), the wiper blade may break. Take care.**

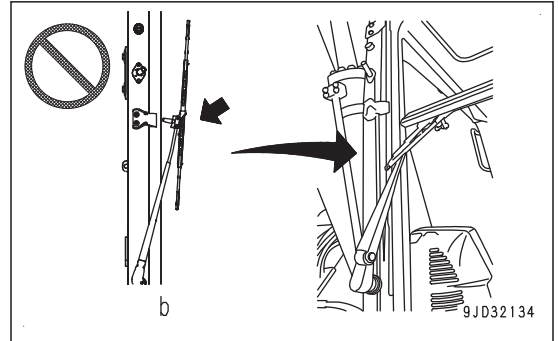

1. Stop the machine on a level ground, lower the work equipment to the ground, then stop the engine.
2. Set the lock lever securely to LOCK position (L).

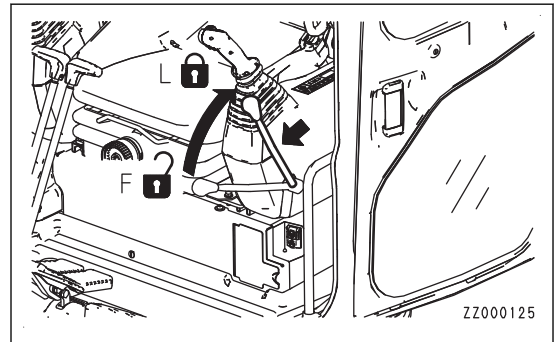

3. Check that the wiper blade is stowed in the right stay. If the wiper blade is stowed in wrong stowing position (b), lift it to move to the correct stowing position (a), or ask your Komatsu distributor for repair.

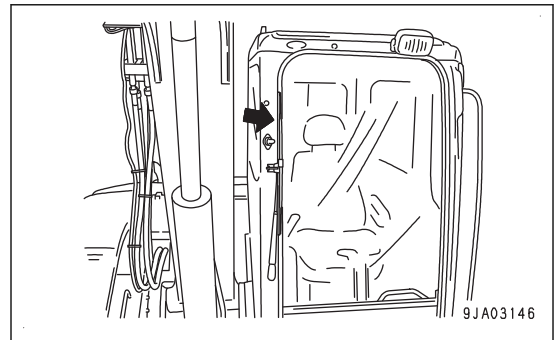

- (a) Correct stowing position  
The wiper blade is on the cab.
- (b) Wrong stowing position  
The wiper blade is on the glass.

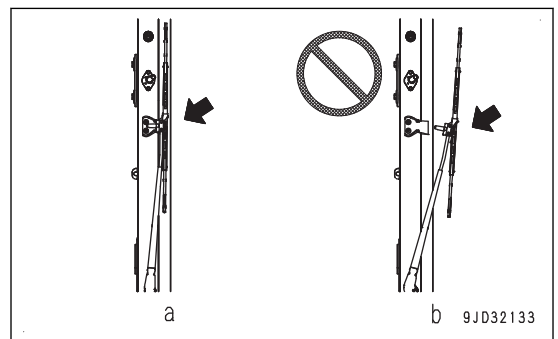



4. Grip right and left handles (A), and pull down lever (B) to release the lock.

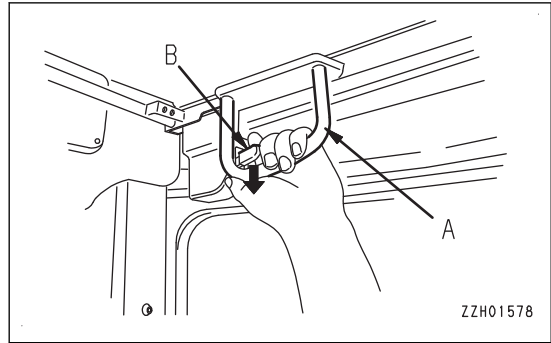

5. Grip handle (C) at the bottom of the front window with your left hand and handle (D) at the top with your right hand, push to the front, then lower slowly.

**REMARK**

The handles (A) on the right and left sides of the front window top are not for pulling up and down the window. Do not pull down the front window with the handles (A).

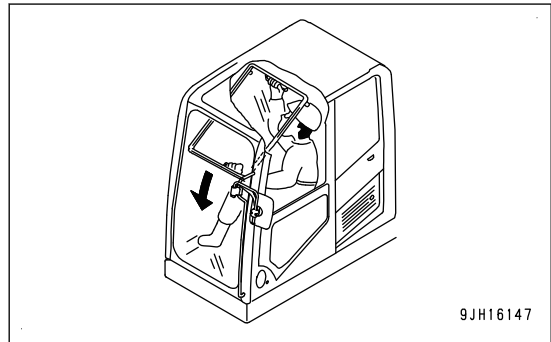
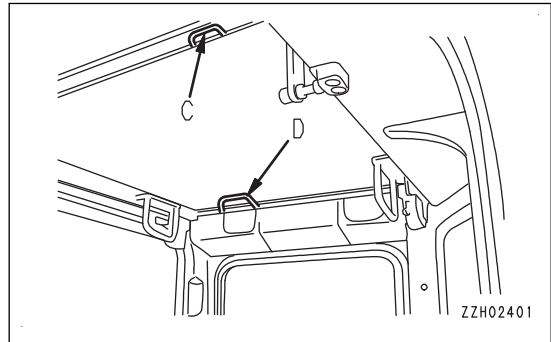

6. When the bottom of the window reaches the top of lower side window, push the top of the window to the front to push it against right and left lock catches (G) and engage the lock.

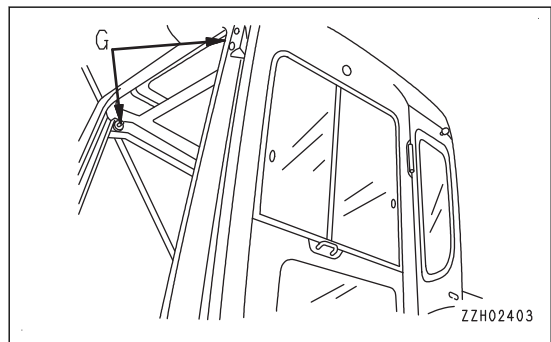

7. Check that lever (B) is securely at LOCK position.
  - If the arrow on lock case (F) matches the position of the arrow on lever (B), the lock is engaged. Check visually.
  - If the arrow on lock case (F) does not match the position of the arrow on lever (B), the lock is not engaged. Repeat the operation in step 5 to engage the lock.

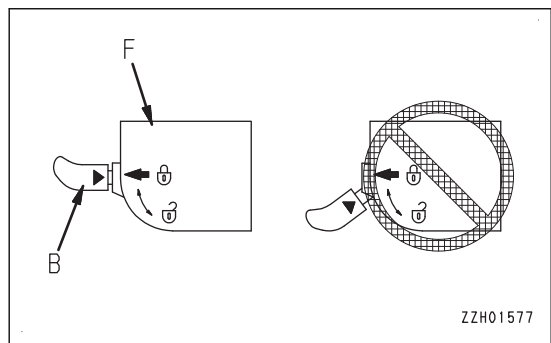

## Removal of front window (lower side)

1. Open the front window (upper side), then hold grip (1), pull up, and remove the lower side window.

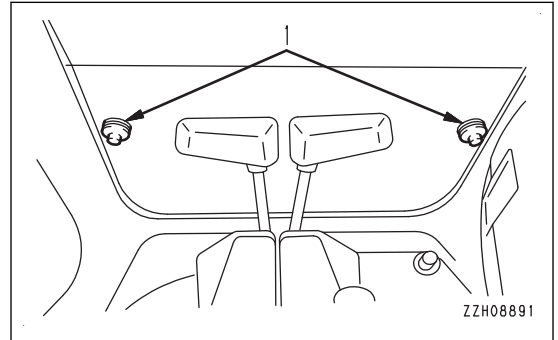

### REMARK

If sand or dust is collected at the bottom of the front window (lower side), it will be difficult to remove the window. In addition, when stowing, the sand and dust stuck to the glass will be carried inside the cab. To prevent this, clean area (A) before removing.

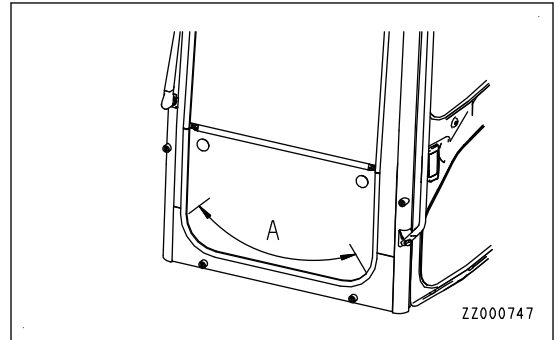

2. After removing the bottom window, store it at the rear of the operator's cab and lock it securely with lock (2). The procedure for stowing is as follows.

- 1) Set it with the protruding part of grip (1) on the glass on the inside and insert the bottom of the glass into the groove in seat (3).
- 2) Insert the top right of the glass into the groove in seat (4).

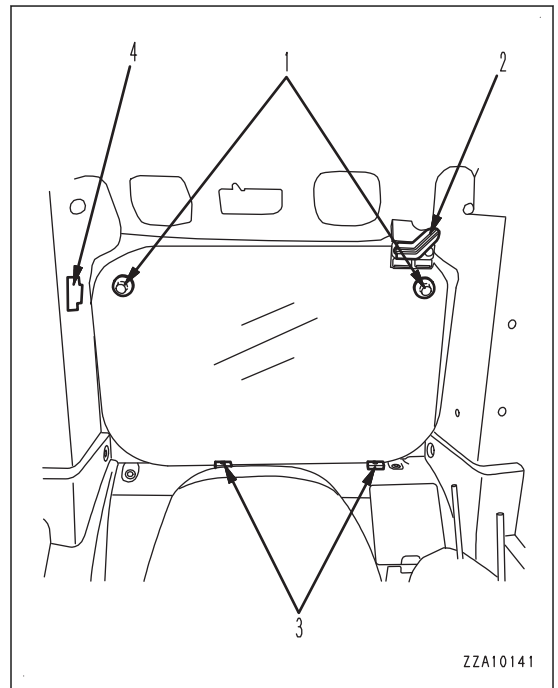

- 3) Set lock (2) to FREE position (F) and press the upper side of the glass.

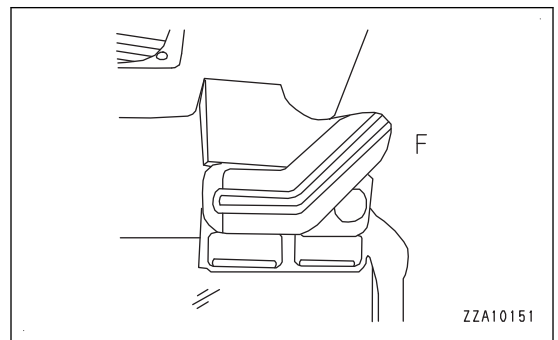

- 4) Turn lock (2) 90 deg. counterclockwise to LOCK position (L) to fix the upper side of the glass.

**NOTICE**

**When stowing the glass, lock it securely and check that there is no play. If there is play or the lock is not properly applied, there is danger that the glass may fall.**

- 5) When removing the bottom window from the stowing position, perform the stowing procedure in the reverse order.

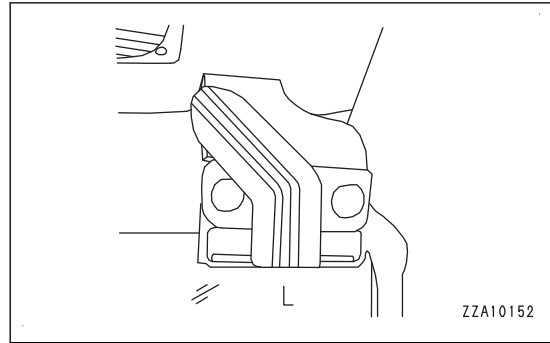

## SLIDE DOOR

**! CAUTION**

- Be sure to check that the sliding door is locked in position both when it is open and when it is closed.
- Always place the machine on a level ground when opening or closing the door.  
Avoid opening or closing the door on a slope, since there is a danger that the operating effort may suddenly change.
- When opening or closing the door, always use door handle (1) and knob (2).
- Be careful not to get your hands caught between the front pillar or center pillar.
- When there is anyone inside the cab, always call out a warning before opening or closing the door.

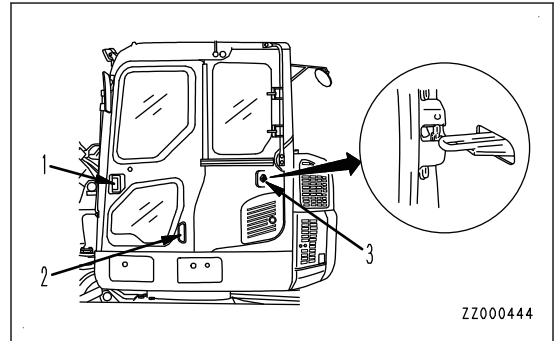

## Door lock

When closing the door, pull door handle (1) back to unlatch lock (3), then pull the door to the front.

**EMERGENCY ESCAPE HAMMER****! CAUTION**

- If it is necessary to break the window glass with the hammer, be extremely careful not to get injured with scattered pieces of broken glass.
- To prevent injury, remove the broken pieces of glass remaining in the frame before escaping through the window. Be careful also not to slip on the broken pieces of glass.

If it should become impossible to open the cab door for any reason, and it is necessary to make an emergency escape from the operator's compartment, use hammer to escape.

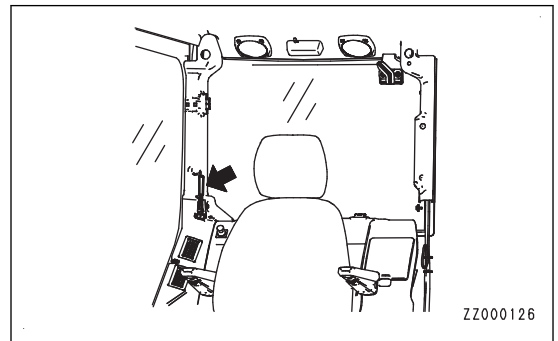

To escape from the operator's cab, use hammer to break the glass and escape through the window.

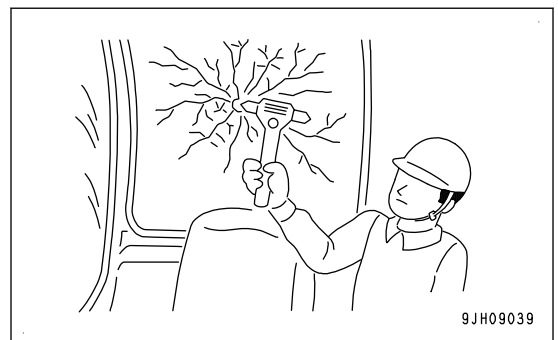

## COVER WITH LOCK

Use the starting switch key to open and close the locks on the covers.

Insert the key completely until the shoulder (A) reaches to the end. If the key is turned before it is inserted all the way, it may break.

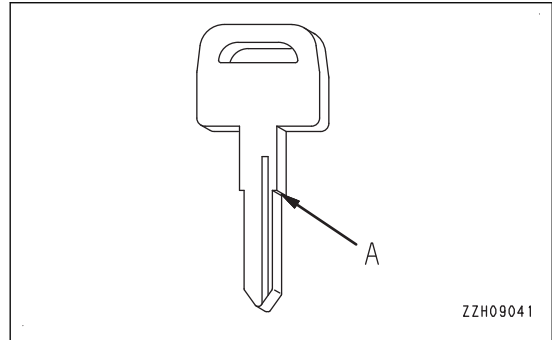

## MAGAZINE BOX

A pocket is provided on the left side of the operator's seat for keeping Operation and Maintenance Manual and oil chart.

Keep Operation and Maintenance Manual in this pocket so that it can be read whenever necessary.

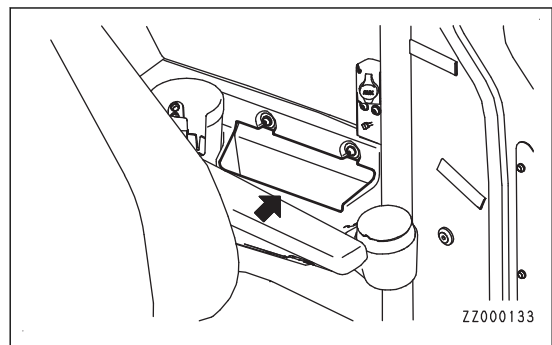

## CUP HOLDER

The cup holder is located on the left side of the operator's seat.

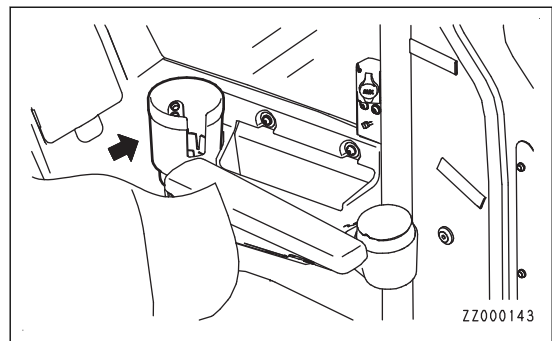

## ASHTRAY

Ashtray is on the left side of the operator's cab.

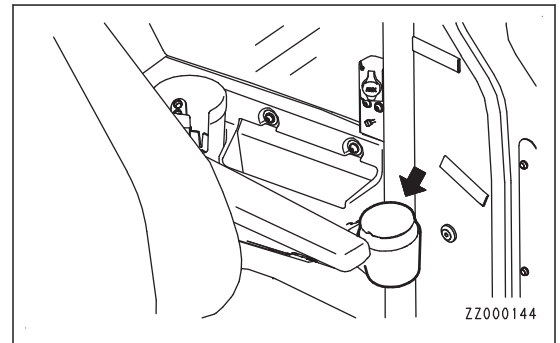

Always extinguish your cigarette before putting it in the ashtray, then be sure to close the lid (A).

When removing ashtray, open the lid (A), hold ashtray body (B), and twist it.

Or, push up ashtray body (B) with a finger through the hole at the bottom of ashtray holder (C).

### NOTICE

**If you hold and twist lid (A) of ashtray, there is a danger that the ashtray may break.**

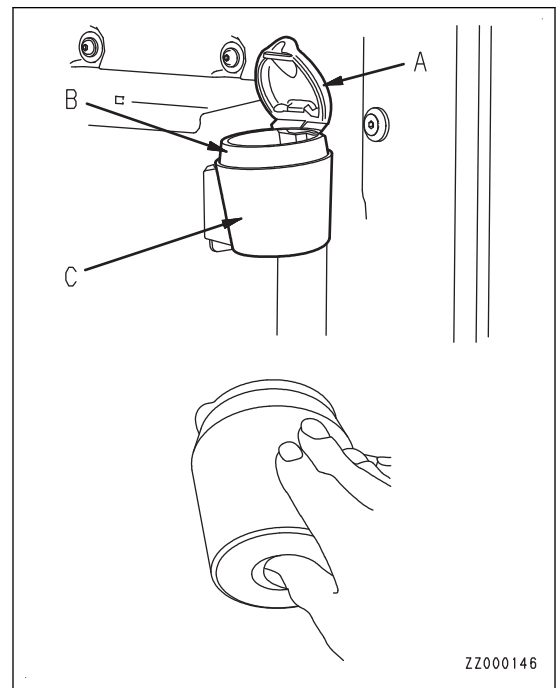

### POWER SUPPLY OUTLET

**NOTICE**

When installing an electrical component which is not a product of Komatsu, limit its capacity to maximum 240 W in the 24 V specification (equivalent to 10 A). When installing an electrical component of capacity larger than above value, consult your Komatsu distributor.

The connectors to take out electric power for optional parts are fixed to the right and left under the floor console. Remove them when using.

Take out power from these connectors for electric parts which are not products of Komatsu.

Left connector No.: M10

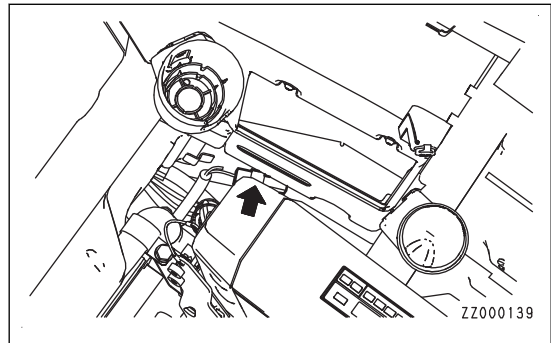

Right connector No.: M09

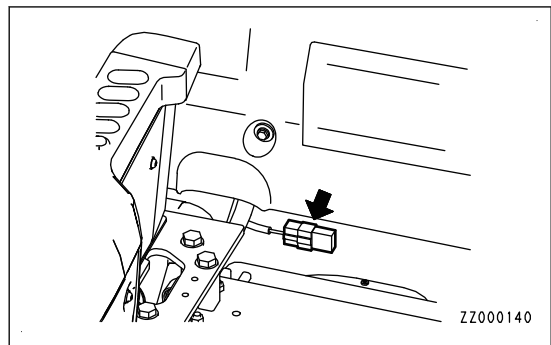

For the connection type connector, see the following table.

Left connector No.: M10

	X type housing (2 poles)		Terminal		Grommet	
	Body	Rear holder	AVS 0.5 to 1.25	AVS 2 to 3	AVS 0.5 to 1.25	AVS 2 to 3
Komatsu part No.	08055-00212	08055-00230	08055-00040	08055-00041	08055-00060	08055-00061

Right connector No.: M09

	X type housing (2 poles)		Terminal		Grommet	
	Body	Rear holder	AVS 0.5 to 1.25	AVS 2 to 3	AVS 0.5 to 1.25	AVS 2 to 3
Komatsu part No.	08056-00212	08056-00230	08055-00040	08055-00041	08055-00060	08055-00061

## 24 V power source

### NOTICE

**Do not use as a power supply for 12 V equipment.  
This will cause failure of the equipment.**

When cigarette lighter is removed, the lighter socket can be used as a power source.

The capacity of the cigarette lighter is 85 W (24 V x 3.5 A).

### REMARK

Use this power source while engine is running.

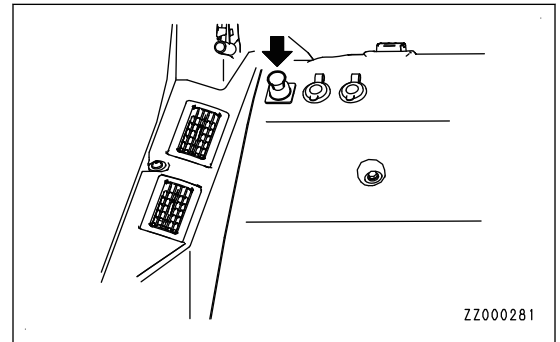

## 12 V power source

This power source can be used up to a capacity of 144 W (12 V x 12 A).

When it is used at 1 place: 144 W (12 V x 12 A)

When it is used at 2 places: 144 W in total

### REMARK

Use this power source while engine is running.

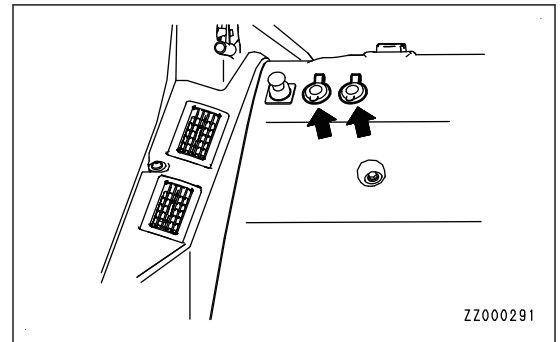



**FUSE**

**NOTICE**

**Before replacing a fuse, be sure to turn the starting switch to OFF position, then turn the battery disconnect switch to OFF position.**

- The fuse holder is installed inside the cover at the rear left of the operator's seat.
- The fuses protect the electrical component and wiring from burning out.
- If the fuse becomes corroded, or white powder can be seen, or the fuse is loose in the fuse holder, replace the fuse.
- Replace the fuse with the one of the same capacity.

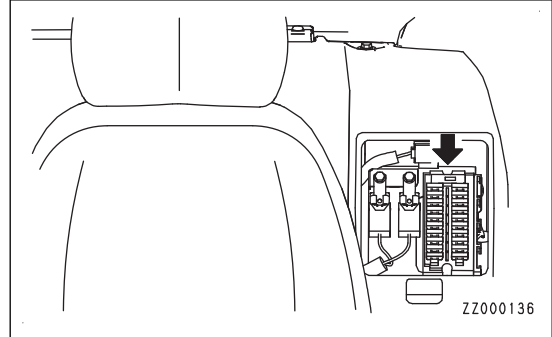

**Fuse capacities and circuit names**

No.	Fuse	Name of circuit
(1)	5 A	Redundant resistor, working lamp switch
(2)	30 A	Solenoid valve
(3)	5 A	PPC hydraulic lock solenoid
(4)	10 A	Window washer, Cigarette lighter
(5)	10 A	Horn
(6)	5 A	Spare
(7)	10 A	Revolving lamp (if equipped)
(8)	10 A	Radio, speaker, L.H. knob switch
(9)	20 A	Working lamp
(10)	20 A	Air conditioner unit
(11)	10 A	Headlamp
(12)	10 A	Optional power supply (1)
(13)	20 A	Optional power supply (2), 12 V power supply
(14)	5 A	Air conditioner ECU power source
(15)	5 A	Key ACC signal
(16)	10 A	Radio backup, room lamp, system operating lamp
(17)	20 A	Monitor, Pump controller
(18)	30 A	Engine controller
(19)	5 A	Air conditioner ECU backup
(20)	10 A	Optional power supply (continuous power supply)

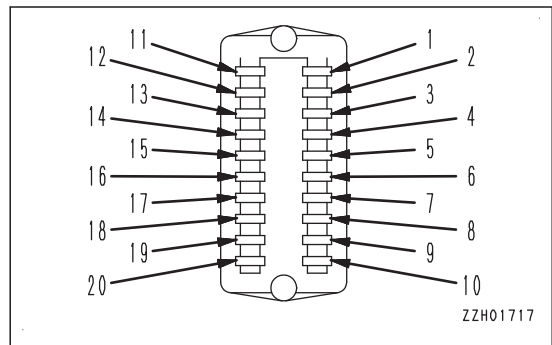

**REMARK**

- Spare fuses are installed in the back of the fuse holder lid at the rear left of the operator's seat.
- After using spare fuses, replenish them immediately.
- One spare fuse is installed for each 5 A, 10 A, 20 A, 25 A, and 30 A.

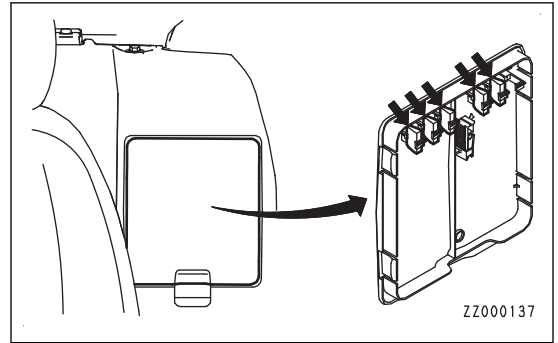

**FUSIBLE LINK**

**NOTICE**

**When replacing the fusible link, be sure to turn the starting switch to OFF position and, after confirming that the system operating lamp is not lit, set the battery disconnect switch key to OFF position.**

If the following phenomena occur, fusible links are suspected of disconnection. Open the engine hood and check the fusible link, and replace it if necessary.

- If the engine starting motor does not operate even when the engine starting switch key is turned to the START position, fusible link (1) may be broken.
- If the battery goes dead, fusible link (2) may be broken.
- If the engine does not start easily in cold weather even if the starting switch is set to HEAT (preheat) position, fusible link (3) may be broken.

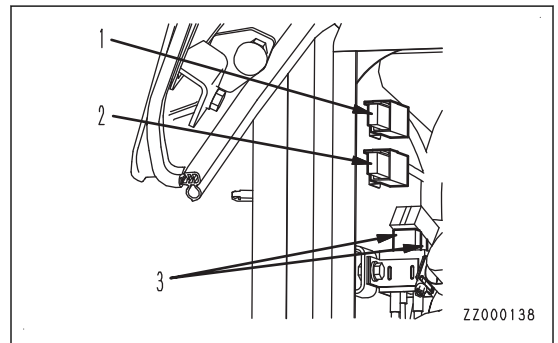

**REMARK**

A fusible link refers to the large-sized fuse wiring installed in the high current flow portion of the circuit. It protects electrical components and wiring from burning, in the same way as an ordinary fuse.

No.	Capacity	Name of circuit	Connector No.	Part No.
(1)	65 A	Standard power supply	F02	22U-06-11270
(2)	45 A	Continuous power supply	F03	20T-06-81230
(3)	120 A	Alternator	F05	421-06-22830
		Preheating	F06	

## CONTROLLER

### NOTICE

- Do not let water, mud, or beverage spill on the controller. This will cause failures.
- If any problem occurs in the controller, do not repair it by yourself. Contact your Komatsu distributor for repair.

The chassis controller and KOMTRAX controller are installed inside the rear cover at the rear of the operator's cab.

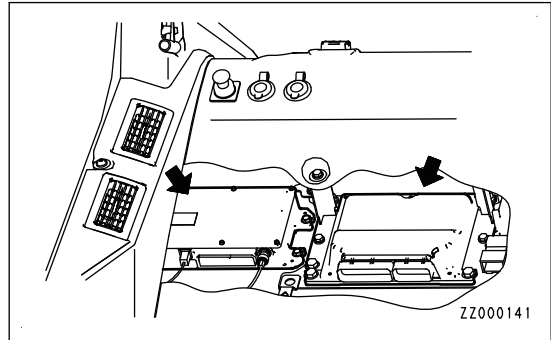

The engine controller is installed to the frame on the inside of the counterweight at the rear of the engine.

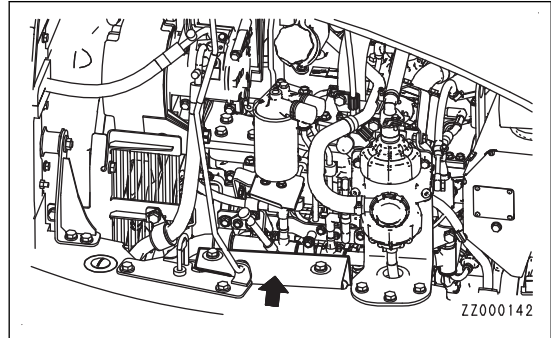

## TOOL BOX

Open the cover on the left side of the machine, and you see the standard toolbox in it.

Store the tools in the attached tool bag.

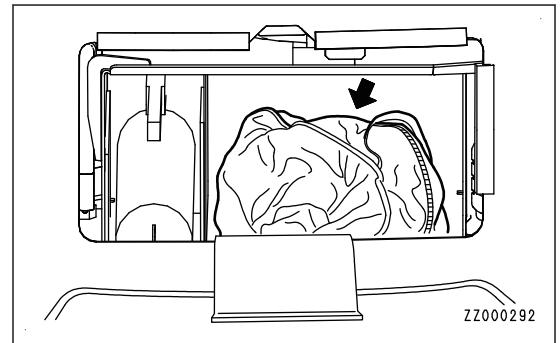

## GREASE PUMP HOLDER

Open the cover on the left side of the machine, and you see the grease pump storage place.

When storing the grease pump, pass its nozzle through the hole at the end until it stops.

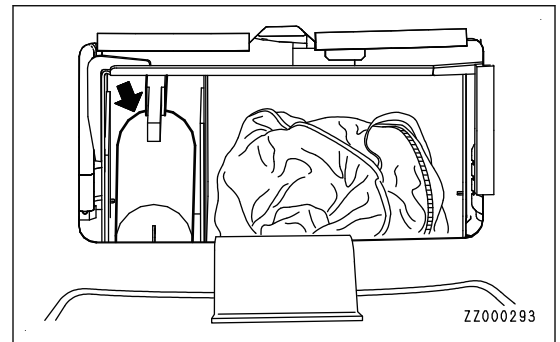

## FIRE EXTINGUISHER

(if equipped)

A fire extinguisher is prepared at the rear part inside the operator's cab.

The directions are described on the nameplate affixed to the fire extinguisher. Just in case, carefully read and understand them beforehand.

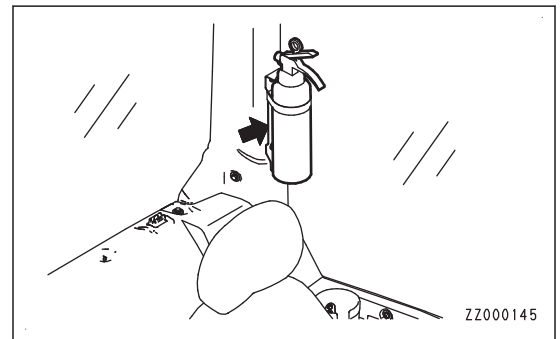

### BATTERY DISCONNECT SWITCH

#### CAUTION

- Do not operate the battery disconnect switch while the engine is running. The large current generated by the alternator may burn the electric parts and cause a fire. When operating the battery disconnect switch, always stop the engine.
- If the battery disconnect switch is turned to OFF position, always remove the switch key. If someone turns the key to ON position carelessly, this is extremely dangerous.

#### NOTICE

- Keep battery disconnect switch in ON position except the following cases.
  - When the machine is stored for a long time (more than a month)
  - When repairing the electrical system
  - When performing electric welding
  - When handling the battery
  - When replacing the fuse, etc.
- Do not turn battery disconnect switch to OFF position while the system operating lamp is lit. If the battery disconnect switch is turned OFF while this lamp is lit, the data in the controller may be lost.
- If this switch is turned to OFF position, all the electrical system is cut out and the functions of KOM-TRAX stop. In addition, the time information of the clock and the radio tuning information may be lost. In this case, set the information again. For detail, see “CLOCK ADJUSTMENT” and “HANDLE RADIO”.

The battery disconnect switch is used for cutting out the electricity from the battery.

This switch is installed inside the cover on the left side of the machine.

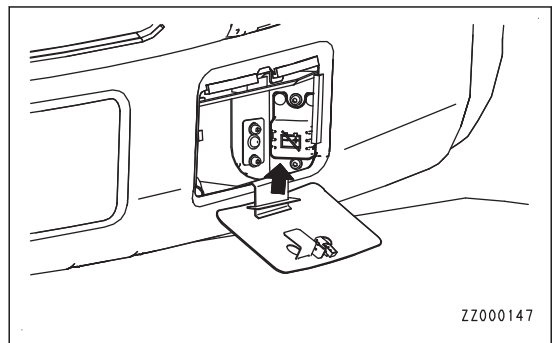

Raise rubber cover (2), and the battery disconnect switch is seen.

#### REMARK

Operate this switch while system operating lamp (3) is OFF.

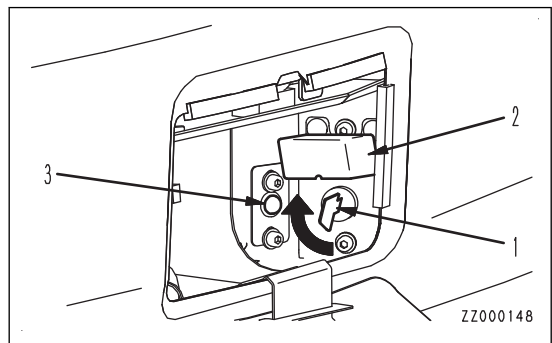

**(O): OFF position**

Switch key (1) can be pulled out (and inserted) and the current from the battery is cut out.

**(I): ON position**

The current from the battery flows into the circuit.

Before starting the machine, be sure to set the switch to this position.

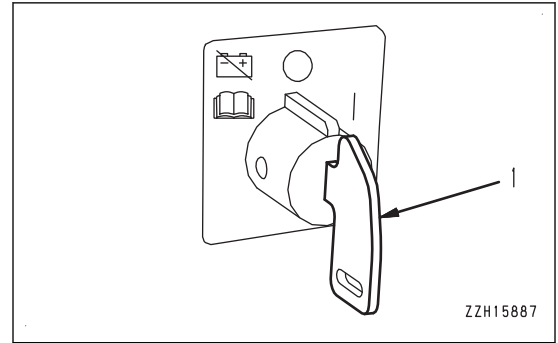
**SYSTEM OPERATING LAMP**

System operating lamp (1) indicates that the controller mounted on the machine is turned ON.

System operating lamp (1) lights up in green when the controller is turned ON and goes out in a few minutes after the starting switch is turned to OFF position.

Before operating the battery disconnect switch, check that system operating lamp (1) is turned OFF.

**NOTICE**

**If the battery disconnect switch is turned OFF while the system operating lamp is lit, the data in the controller may be lost.**

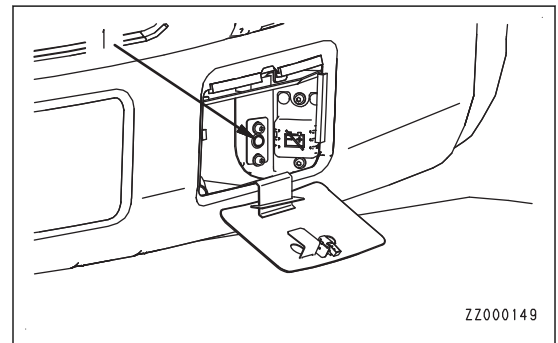
**REMARK**

- Even if the starting switch is in OFF position, the controller may operate. The system operating lamp lights up at this time, but it is not a failure.
- After the starting switch has been turned OFF, the system operating lamp may stay lit for a long time. In such case, consult your Komatsu distributor.
- The system operating lamp may look slightly luminous in the dark when it is not lit. It is due to the minute leakage of current and this is not an abnormal phenomenon.

**HANDLING QUICK COUPLER****⚠ WARNING**

**Handling the quick coupler involves a risk. Handling it without caution may cause serious personal injury or death. Observe the following caution strictly.**

- Use such a quick coupler that you can check it from the operator position that the attachment or bucket is completely locked.
- Use only quick coupler which include a pilot operated check valve in the locking cylinder. This is to eliminate the risk of the bucket or attachment which may move if the oil pressure is lost. Consult the manufacturer of the quick coupler if there is anything unclear.
- Read thoroughly the Operation and Maintenance Manual for the quick coupler, and follow the recommendations. Consult your Komatsu distributor if there is anything unclear in installation or operation.
- Pressure regulation valve (5) and (6) allow the attachment pressure and the release pressure for the quick coupler to be limited according to the coupler manufacture's recommendation respectively. Maximum circuit pressure: 34.3 MPa {350 kg/cm<sup>2</sup>, 4980 PSI}
- Be sure that the quick coupler has been installed by a qualified technician. Consult your Komatsu distributor if there is anything unclear.

**EXPLANATION OF EQUIPMENT ON QUICK COUPLER**

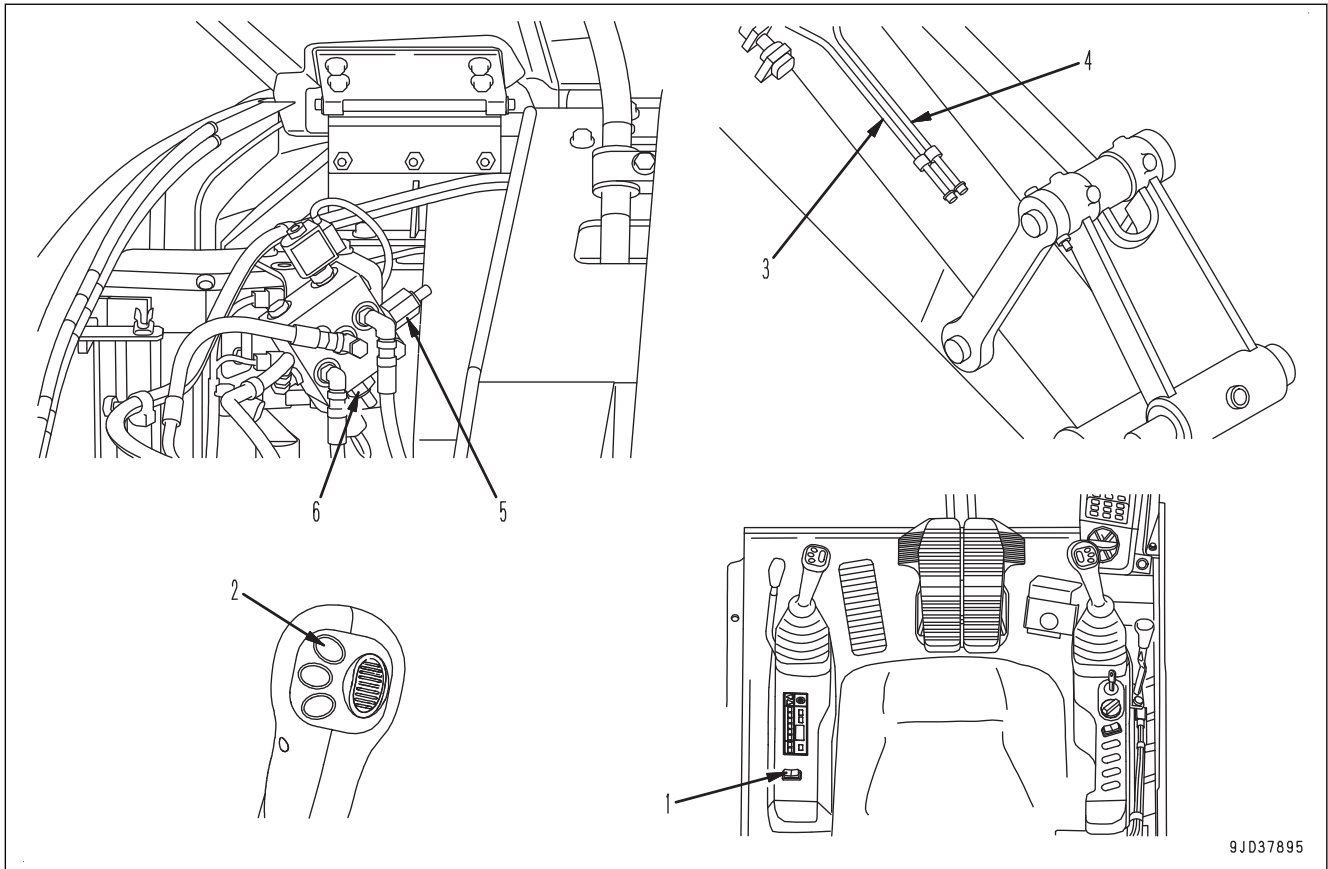

- |  |   |
|--|---|
| 1. Quick coupler main switch             | 4. Piping (quick coupler release direction)       |
| 2. Quick coupler operation switch        | 5. Adjustable pressure adjustment valve (Attach)  |
| 3. Piping (quick coupler lock direction) | 6. Adjustable pressure adjustment valve (Release) |

**TO RELEASE A BUCKET OR ATTACHMENT**

**⚠ WARNING**

**Pressure in the system can cause injury. Follow all instructions in ATTACHMENT REMOVAL AND INSTALLATION.**

If the bucket or attachment has any hydraulic connections to the machine these must be disconnected before proceeding.

1. Position the attachment on the ground safely where it is to be left. Take care that it will not roll or slide after release.

(1) Operation switch

**REMARK**

The switch has a safety lock mechanism to prevent accidental operation. Slide the lock towards you then rock the switch. The lamp on the switch will come on and a warning buzzer will sound.

**NOTICE**

**Operation will only take place if button (2) is also pressed.**

(A) : When depressed at this point quick coupler deactivated. (Lock bucket/attachment)

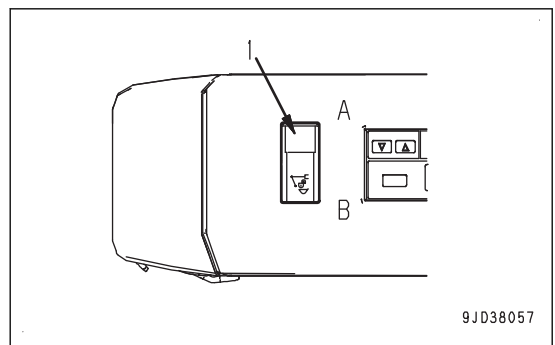

(B) : When depressed at this point quick coupler is ready to be activated. (Release bucket/attachment)

2. With switch (1) in position "B" press and hold button (2) on the left hand lever to activate quick coupler.
3. Depending on the design of the quick coupler it may be necessary to operate one of the hydraulic functions of the machine (bucket, boom, arm or swing) to raise the pressure in the hydraulic system.

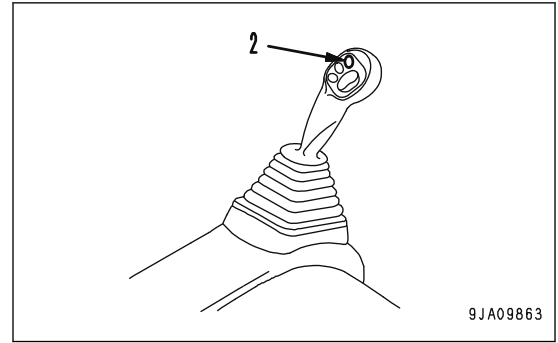

The quick coupler will now release the attachment/bucket.

## TO PICK UP A NEW BUCKET OR ATTACHMENT

### WARNING

- Check daily that the hoses and fittings in the quick coupler piping system are in good condition. Pay particular attention to the hoses and fittings at the arm end as these can be damaged easily. In case of damage or leakage of oil stop work. Loss of oil could lead to the bucket or attachment falling and killing an exposed person. The damage or leakage must be repaired before continuing work.
- This machine has a system installed to give a warning if there is a failure to maintain pressure in the quick coupler system. If the buzzer sounds in the cab make sure that the cause is clarified before continuing work. In particular check for leaks in the system. If in doubt call your Komatsu distributor.

1. Position the quick coupler over the new bucket or attachment.
2. Operate switch (1), and with switch (1) in position "B" press and hold button (2) on the left hand lever, to activate quick coupler.

#### NOTICE

The switch has a safety lock mechanism to prevent accidental operation. Slide the lock towards you then rock the switch. The lamp on the switch will come on and a warning buzzer will sound.

3. Depending on the design of the quick coupler it may be necessary to operate one of the hydraulic functions of the machine (bucket, boom, arm or swing) to raise the pressure in the hydraulic system. The quick coupler will move to released position.
4. Position the quick coupler in the mating portion of the bucket or attachment, moving the bucket cylinder, arm and boom as necessary.

Follow the quick coupler manufacturer's instructions.

5. Release button (2).

If the bucket or attachment needs a connection to the hydraulic system of the machine, follow all instructions in ATTACHMENT REMOVAL AND INSTALLATION.

The quick coupler will lock onto the bucket or attachment, if necessary operate one of the machine control levers to raise the system pressure.

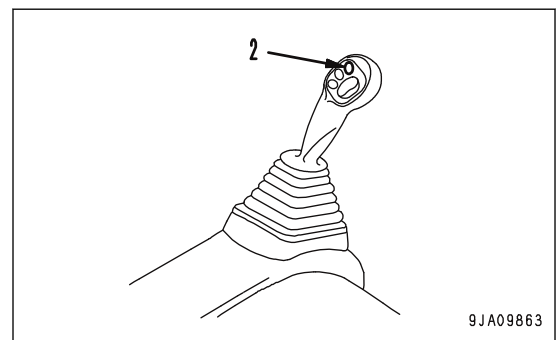
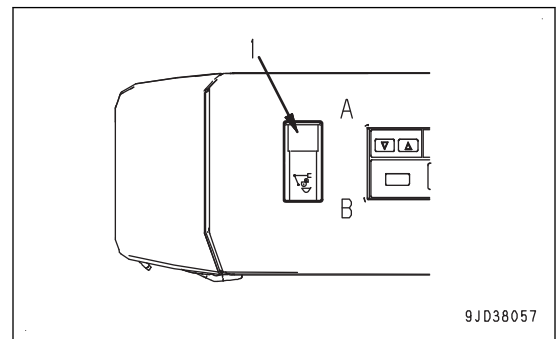



**⚠ WARNING**

European safety standards require that it is possible to check the locked position of the quick coupler from the operator's position. Failure to check could cause the death of exposed persons. Check carefully that all the locking of the quick coupler is complete and secure. Follow the manufacturer's instructions carefully, including the installation of any safety device, if required.

- Return switch (1) to position "A" (OFF).  
The lamp will go off and the buzzer stop.

**Komatsu Closed Crankcase Ventilation (KCCV)**

KCCV is a device to clean the gas discharged from the engine crankcase with the filter element and return it to the engine air intake system.

**NOTICE**

- The KCCV filter element needs to be replaced every 2,000 hours.
- If the engine is operated without KCCV filter element or if a filter element other than the Komatsu genuine one is used, the engine sucks oil and foreign material which can cause a failure. Always install Komatsu genuine KCCV filter element.
- The filter element cannot be flushed. Never reuse the filter element since it can cause a performance decrement of engine, and it result in a failure even if it is cleaned.

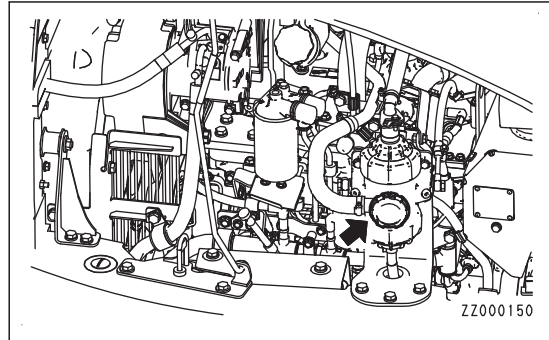

## KOMTRAX

### **WARNING**

- **Never disassemble, repair, modify, or move the wireless communication terminal, antenna, or cables. This may cause failure or fire on the wireless equipment or the machine itself.**
- **Near the blasting jobsite, there may be a danger of unexpected explosion due to use of the wireless equipment and resulting serious personal injury or death.**  
**If you have to operate the machine within 12 m {within 39 ft 4 in} from the remote-controlled blasting device, the power supply cable of the wireless communication device must be disconnected in advance.**

KOMTRAX is a vehicle management system that remotely manages the machines equipped with the KOMTRAX device by using satellite communication or portable radio communication.

The GPS (Global Positioning System), receiver, and communication system are equipped in the vehicle management system.

The machine information such as the machine maintenance, maintenance management, operating situation management, and machine location management is gathered from the inside network of the machine. It can be useful for you to perform the machine management by yourself. Your Komatsu distributor uses the above machine information for supply of service to the customers, improvement of our products and service, etc.

The type of information which is sent from the machine may vary depending on the machine. For the radio station establishment of KOMTRAX, consult your Komatsu distributor.

### **POWER SUPPLY FOR KOMTRAX**

- Even when the key in the starting switch of the KOMTRAX system is at OFF position, a small amount of electric power is consumed.  
It is recommended to run the engine periodically to charge the battery.
- When using the battery disconnect switch, turn the starting switch to OFF position and, after checking that the system operating lamp is not lit, set the battery disconnect switch key to OFF position and pull it out.  
When the battery disconnect switch is turned to OFF position, it is possible to prevent power consumption of the battery, but the functions of KOMTRAX stop at the same time.
- If the power supply cable of KOMTRAX system device has to be disconnected, contact your Komatsu distributor.

# MACHINE OPERATIONS AND CONTROLS

## CHECKS AND ADJUSTMENT BEFORE STARTING ENGINE

### METHOD FOR WALK-AROUND CHECK

Before starting the engine, walk around the machine and look at the underside of chassis for anything unusual like loose bolts and nuts, leakage of fuel, oil and coolant. Also check the condition of the work equipment and the hydraulic system.

Check also for loose wiring, play, and accumulation of dust in places that get very hot and are exposed to extremely high temperatures.

### **⚠ WARNING**

- **When performing checks or maintenance of the inside of the engine hood or dirt cover, fully open the hood or cover and be sure to fix it with the stopper.**
- **Accumulation of flammable material or leakage of fuel or oil around the high temperature parts such as the engine muffler or battery may cause fire. Check carefully, and if any problem is found, repair it or contact your Komatsu distributor.**

If the machine is inclining, make it level before checking.

Always perform the following inspections and cleaning every day before starting engine for the day's work.

1. Check for damage, wear, play in work equipment, cylinders, linkage, and hoses.  
Check for cracks, excessive wear, play in work equipment, cylinders, linkage, and hoses. If any problem is found, repair it.
2. Remove dirt and debris from around the engine, battery, and radiator.  
Check for dirt accumulated around the engine and radiator. Also check for flammable material (dry leaves, twigs, etc.) around the battery, engine muffler, or other high temperature engine parts. If any dirt or combustible materials are found, remove them.  
In particular, check between muffler (1) and muffler cover (2) carefully.  
For removal of dirt from the radiator, see "METHOD FOR CHECKING AND CLEANING RADIATOR FINS, OIL COOLER FINS, AFTERCOOLER FINS, FUEL COOLER FINS, AND AIR CONDITIONER CONDENSER FINS".
3. Check around the engine for coolant and oil leakage.  
Check for oil leakage from the engine and coolant leakage from the cooling system. If any problem is found, repair it.
4. Check the fuel line for leakage.  
Check for leakage of fuel or damage to the hoses and tubes. If any problem is found, repair it.
5. Check the hydraulic equipment, hydraulic tank, hoses, and joints for oil leakage.  
Check for oil leakage. If any problem is found, repair the place where the oil is leaking.
6. Check the undercarriage (track, sprocket, idler, guard) for damage, wear, loose bolts, or leakage of oil from rollers.  
If any problem is found, repair it.
7. Check the handrails and steps for problems and check the bolts for looseness.  
If any problem is found, repair it. Tighten any loose bolts.
8. Check and clean the machine monitor.

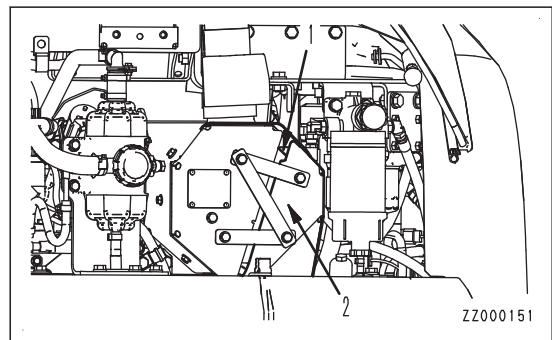

Check the machine monitor in the operator's cab for damage. If it has any damage, replace it. When cleaning dust, etc. on the monitor surface, use a clean, soft, and dry cloth.

**REMARK**

When cleaning the stains deposited on the monitor surface such as dusts, brush them off using a clean, soft and dry cloth.

For sticky dirt such as oil, remove it with glass cleaner for family use on the market (weakly acid to weakly alkaline, containing no abrasive), and then finish-wipe with a clean, soft, and dry cloth.

9. Check the windows for coming off and breakage.

Check the windows for coming off and breakage. If any of them is broken, repair it. If any window comes off or be broken during operation, do not continue the operation but repair the window immediately.

10. Check and clean the rearview mirrors.

Check for damage to the rear view mirror. If it is damaged, repair it. Clean the surface of the mirrors and adjust the angle so that the operator can see the rear lower area (which is not seen behind the engine hood) from the operator's seat.

11. Check the seat belt and mounting hardware.

Check the seat belt and mounting hardware for any abnormality. If any damage is found, ask your Komatsu distributor to replace it with new one.

12. Check the bucket with hook for damage.

Check for damage to the hook, guide, and hook mount. If any problem is found, ask your Komatsu distributor for repair.

13. Check and clean the camera

Check the camera for any abnormality. If any problem is found, ask your Komatsu distributor for repair.

14. Check around muffler for exhaust gas leakage.

Check the pipe connecting the turbocharger and muffler for leakage of exhaust gas (and deposition of soot). If any problem is found, ask your Komatsu distributor for repair.

## METHOD FOR CHECKING BEFORE STARTING

Always check the items in this section before starting the engine each day.

## METHOD FOR DRAINING WATER AND SEDIMENT FROM FUEL TANK

1. Swing the upper structure so that inspection cover (1) is between the tracks.
2. Open inspection cover (1).
3. Place a container under drain hose to receive fuel.

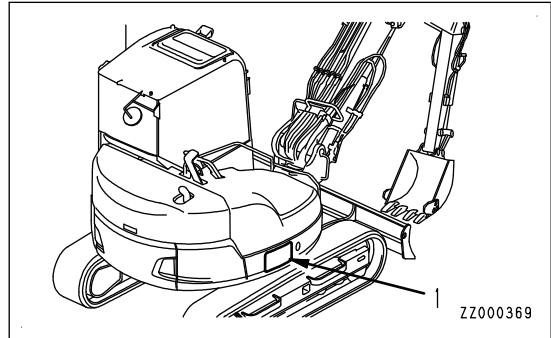

4. Open drain valve (2) to discharge the sediment and water in the bottom together with the fuel.  
Be careful not to get fuel on yourself.
5. When clean fuel flows out, close drain valve (2).
6. Close inspection cover (1).

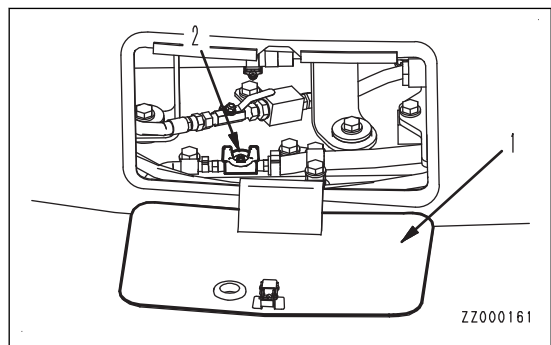

**METHOD FOR CHECKING DUST INDICATOR**

1. Open engine hood (1).
2. Lock it securely with hood support lever (2).

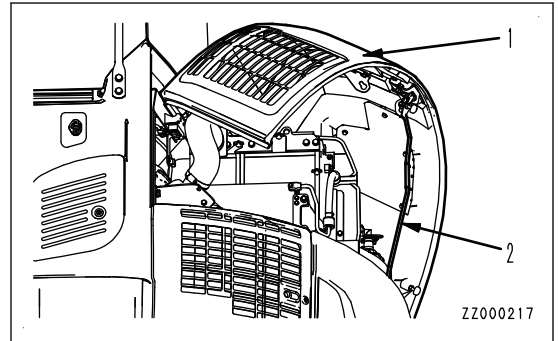

3. Check if the red piston is protruded at the arrow portion of dust indicator (3).
4. If the red piston is protruded, clean or replace the element immediately.

For the cleaning method of the element, see "METHOD FOR CHECKING, CLEANING AND REPLACING AIR CLEANER".

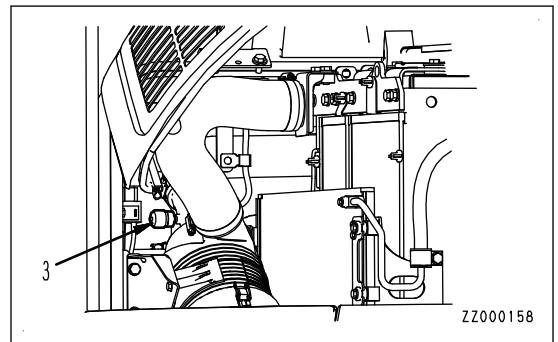

5. After checking, cleaning, and replacing, press the knob of dust indicator (3) to return the red piston to its original position.
6. Remove hood support lever (2) and fix it to the lever lock securely.
7. Close engine hood (1).

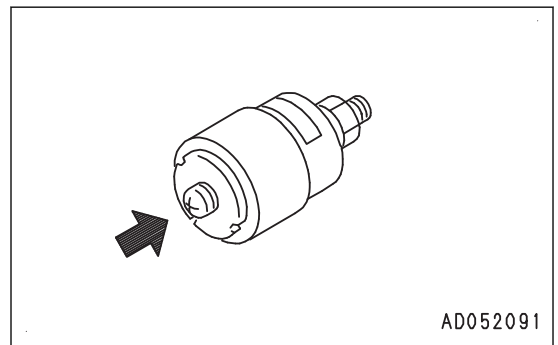

**METHOD FOR CHECKING WATER SEPARATOR, DRAINING WATER AND SEDIMENT**

1. Open engine hood (1).
2. Lock securely with hood support lever (2).

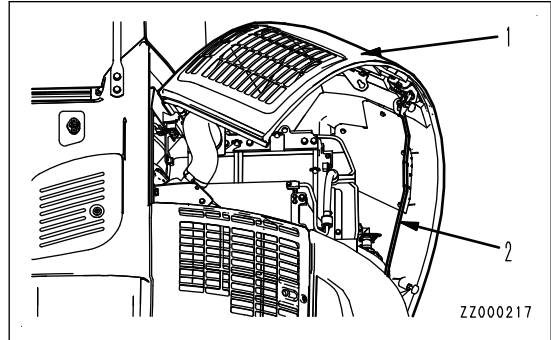

3. Check for water and sediment.  
 The water separator forms one unit with fuel prefilter (3).  
 It is possible to judge the water level and amount of sediment by looking through transparent cup (4).  
 If there is water or sediment accumulated, drain it according to steps 4 to 6.

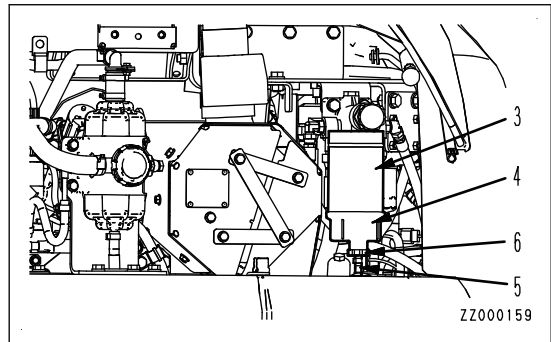

**NOTICE**

**If the water inside transparent cup (4) freezes, check that the frozen water has melted completely, then follow the procedure to drain the water.**

**REMARK**

- If transparent cup (4) is dirty or it is difficult to see the inside, clean transparent cup (4) when replacing fuel pre-filter cartridge (3).
- When the drain valve (6) has been removed during the cleaning operation, coat O-ring with grease and tighten until it contacts the bottom.

4. Place a container under drain hose (5) to receive the water.
5. Loosen drain valve (6) and drain the water.
6. When fuel starts to drain from drain hose (5), tighten drain valve (6) immediately.

**Adjustment of drain valve**

If drain valve (6) is stiff, coat O-ring of the drain valve with grease to make the movement smooth.

1. Open inspection cover (7).

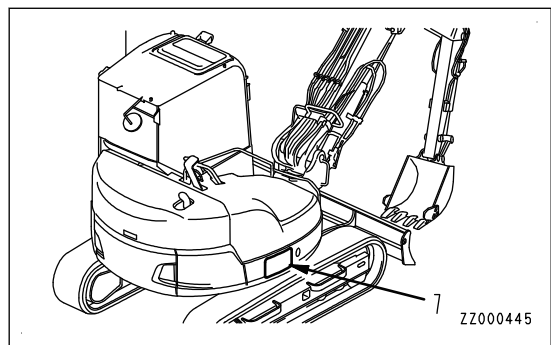

2. Set valve (8) to CLOSE position (S).
3. Place a container under the fuel prefilter cartridge to receive the fuel.

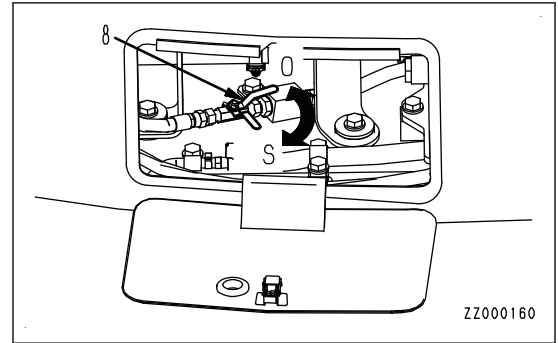

4. Loosen drain valve (6) and drain water and sediments from transparent cup (4), and also drain all the fuel from fuel prefilter cartridge (3).
5. Check that nothing more comes out from drain hose (5), then remove drain valve (6).

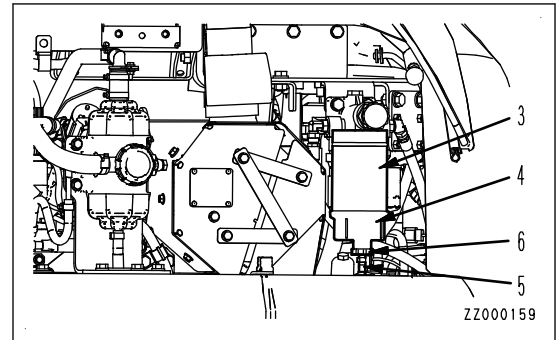

6. Apply a suitable amount of grease to O-ring portion (9).

**REMARK**

When applying grease, be careful not to allow the grease to adhere to water drain port (10) and threaded portion (11) of the drain valve.

7. Tighten drain valve (6) by hand until it contacts the bottom of transparent cup (4).
8. Remove the container for catching the drained fuel.
9. Set valve (7) to OPEN position (O).

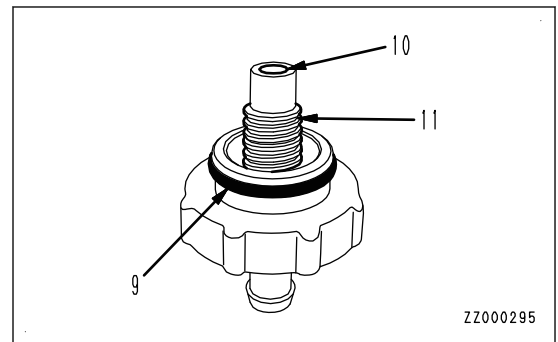



### METHOD FOR CHECKING OIL LEVEL IN HYDRAULIC TANK, ADDING OIL

## ⚠ WARNING

- Immediately after the engine is stopped, its parts and oil are still very hot and may cause burn injury. Wait for the temperature to go down, and start the work.
- When removing the oil filler cap, the oil may spout out. Turn it slowly to release the internal pressure, then remove it.

1. Set the machine posture to state A or B.

“State A”

When setting the machine posture to state A, follow the procedure below.

- 1) Start the engine, and run it at low speed.
- 2) Lower the blade to the ground.
- 3) Retract the arm and bucket cylinders.
- 4) Swing the boom to the center.
- 5) Lower the boom to lower the bucket tooth to the ground.
- 6) Stop the engine.

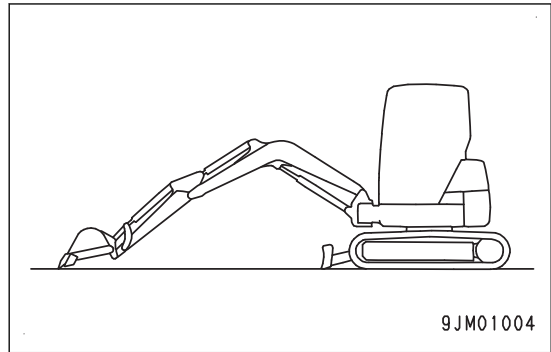

“State B”

When setting the machine posture to state B, follow the procedure below.

- 1) Start the engine, and run it at low speed.
- 2) Lower the blade to the ground.
- 3) Extend the arm and bucket cylinders.
- 4) Swing the boom to the center.
- 5) Raise the boom at maximum RAISE position.
- 6) Stop the engine.

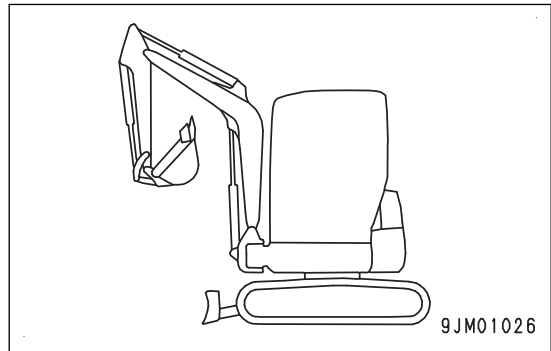

2. Check sight gauge (G) through the small inspection window on the right cover.

If the oil level is in the range shown below, it is proper.

State A: Within range "a"

State B: Within range "b"

If the oil level is below level L, the hydraulic oil is insufficient. Perform the following procedure.

- 1) Open dirt cover (1).
- 2) Lock securely with cover support lever (2).
- 3) Loosen bolt (3) and remove plate (4) on top of oil filler port (F).
- 4) Remove the cap of oil filler port (F) gradually to release the internal pressure.
- 5) Remove the cap of oil filler port (F).
- 6) Add oil through oil filler port (F) until the oil level comes between levels H and L of sight gauge (G).

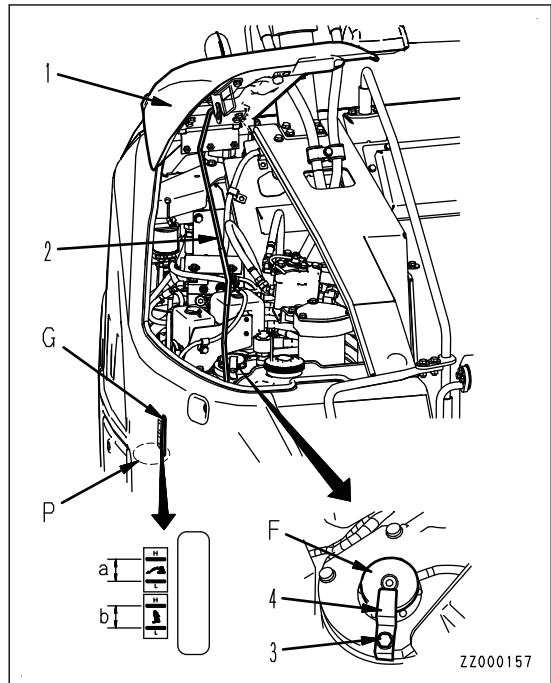

**NOTICE**

**Do not add oil above H line. It may damage the oil circuit and cause the oil to spurt out. If the refilled oil exceeds H level, swing the upper structure until drain plug (P) beneath the hydraulic tank comes between the right and left tracks and stop the engine. Wait for the oil to cool down sufficiently, then drain the excess oil through drain plug (P) into an oil container.**

**REMARK**

The oil level will vary depending upon the oil temperature. Accordingly, use the followings as a guide:

- Before starting the operation: Around L level  
(Oil temperature 10 to 30 °C {50 to 86 °F} )
  - Normal operation: Around H Level  
(Oil temperature 50 to 80 °C {122 to 176 °F} )
- 7) If oil is added in state B, pressurize the hydraulic tank by performing steps 6) to 8).

**NOTICE**

**If the hydraulic tank is not pressurized, air is sucked in the pump and it affects the components badly.**

- 8) Fully extend the boom, arm, and bucket cylinders.
- 9) Remove the oil filler cap.
- 10) Install the oil filler cap.
- 11) Move plate (4) to the center of the cap and fix it with bolt (3).
- 12) Remove cover support lever (2) and fix it to the lever lock securely.
- 13) Close dirt cover (1).

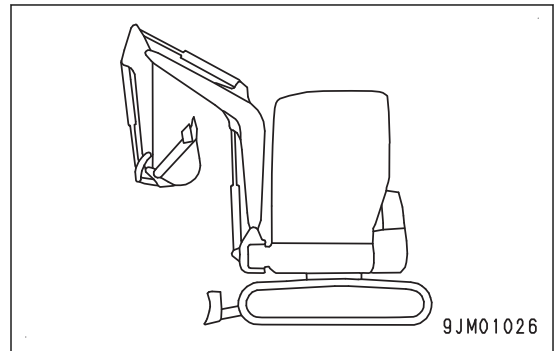

### METHOD FOR CHECKING COOLANT LEVEL, ADDING COOLANT

#### WARNING

- Do not open the radiator cap unless necessary. When checking the coolant level, check the reservoir tank when the engine is cold.
- Immediately after the engine is stopped, the coolant is still hot and the pressure is accumulated in the radiator. If the cap is removed in this condition, it is dangerous that you may get burn injury. Always wait for the temperature to go down, turn the cap slowly to release the pressure, then remove the cap with care.

1. Open dirt cover (1) on the right side of the machine.
2. Lock securely with cover support lever (2).
3. Check reservoir tank (3).  
If the coolant level is within the range between FULL and LOW, the coolant amount is at a proper level.
4. If the coolant level is below LOW, add coolant to FULL level through the filler port of reservoir tank (3).

#### NOTICE

If reservoir tank (3) is empty, leakage of coolant should be suspected. After checking, repair any abnormality immediately. If no abnormality is found, check the level of the coolant in the radiator. If it is low, add coolant of the same density in radiator according to the coolant density table in “METHOD FOR USING FUEL, COOLANT AND LUBRICANTS ACCORDING TO AMBIENT TEMPERATURE”, then add coolant to reservoir tank (3).

5. After refilling with coolant, tighten the cap securely.
6. Remove cover support lever (2) and fix it to the lever lock securely.
7. Close dirt cover (1).

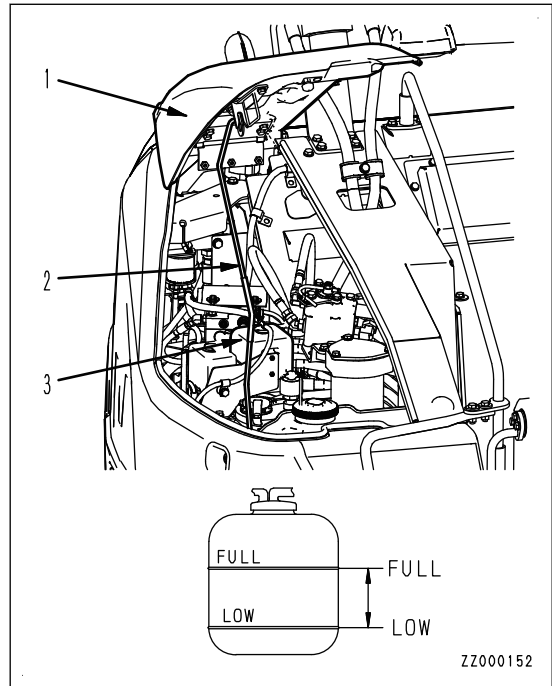

## METHOD FOR CHECKING OIL LEVEL IN ENGINE OIL PAN, ADDING OIL

### WARNING

Immediately after the engine is stopped, its parts and oil are still very hot, and may cause burn injury. Accordingly, wait until they have cooled down before starting the work.

When checking the oil level after the engine has been operated, wait for at least 15 minutes after stopping the engine before checking.

If the machine is inclining, make it level before checking.

1. Open engine hood (1).
2. Securely lock the hood with hood support lever (2).
3. Pull out dipstick (G) and wipe the oil off with a cloth.
4. Fully insert dipstick (G) into the dipstick pipe, then remove it.
5. Check if the oil is sticking up to between marks H and L on dipstick (G).  
It is appropriate if the oil level is between marks H and L.
6. If the oil level is below the L mark, add oil through oil filler port (F).
7. If the oil level is higher than H, decrease it to a proper level according to the following procedure.
  - 1) Place a container under drain plug (P) at the bottom of the engine oil pan to catch the oil.
  - 2) Drain excessive engine oil through drain plug (P).
  - 3) Check the oil level again.
8. If the oil level is proper, tighten the oil filler cap securely.
9. Remove hood support lever (2) and fix it to the lever lock securely.
10. Close engine hood (1).

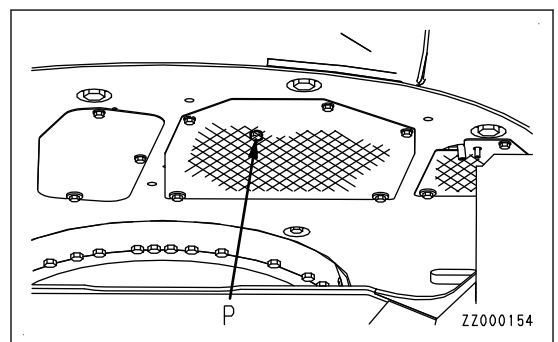
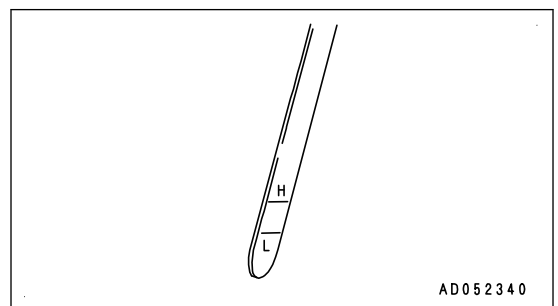
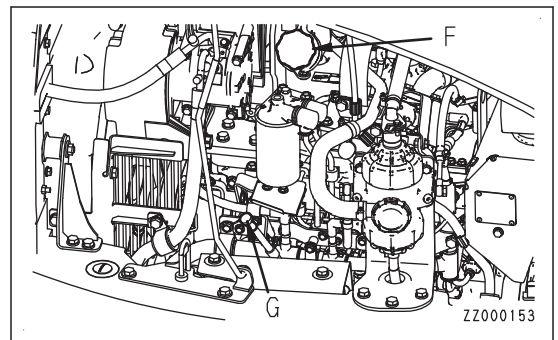
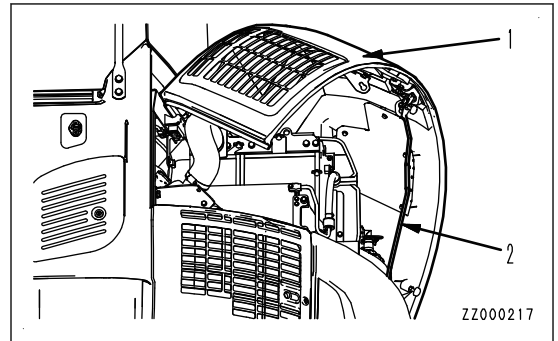

---

## METHOD FOR CHECKING ELECTRIC WIRING

### CAUTION

- If fuses are frequently blown or if there are traces of short-circuiting on the electrical wiring, promptly ask your Komatsu distributor to locate the cause of it and to make the repair.
  - Keep the top surface of the battery clean and check the breather hole in the battery cap. If it is clogged with dirt or dust, wash the battery cap to clear the breather hole.
- 

### NOTICE

**Perform inspection for the piping of “battery”, “starting motor”, and “alternator” with particular care.**

- Perform inspection to confirm that the fuses have no defect and their capacity is proper.
- Perform inspection to confirm that there is no disconnection or trace of short-circuiting in the electric wiring and no damage to the coating.
- Perform inspection to confirm that there is no loose terminals, and tighten any loose parts if found.
- Check if there is any accumulation of combustible material around the battery, and remove such combustible material.

## METHOD FOR CHECKING FUEL LEVEL, ADDING FUEL

**⚠ WARNING**

When adding fuel, never spill the fuel or let it overflow. The fuel may cause fire.

If any fuel has spilled, wipe it up completely. If fuel has spilled over soil or sand, remove that soil or sand.

Fuel is highly flammable and dangerous. Never bring any open flame near fuel.

1. Turn the starting switch to ON position.
2. When the fuel level caution lamp lights up in red, check the fuel level with fuel level gauge (2) on the monitor.

When the fuel gauge pointer indicates the red range, the fuel quantity is 32 ℓ (8.45 U.S.Gal) or less.

Since the fuel level is low, add fuel.

3. After checking, turn the starting switch back to OFF position.

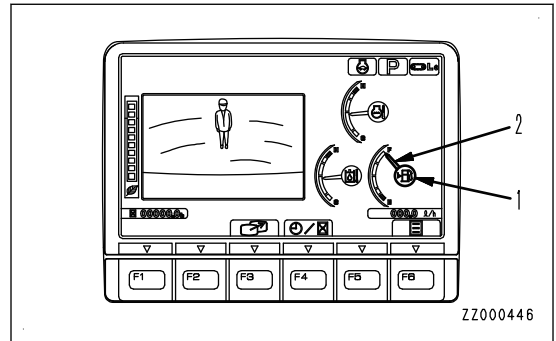

4. Open dirt cover (3).
5. Lock securely with cover support lever (4).
6. Open fuel filler cap (F) of the fuel tank.

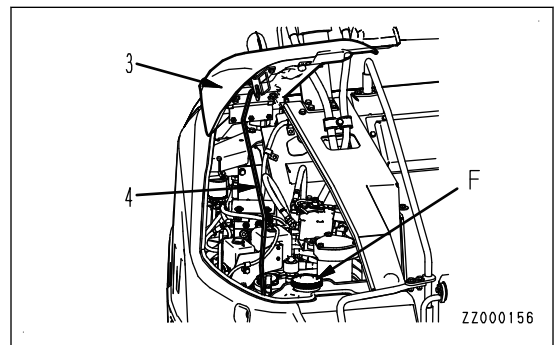

7. Add fuel through the fuel filler port until float gauge (G) rises to the maximum position.

Fuel tank capacity: 125 ℓ (33 U.S.Gal)

Position (a) of tip of float gauge (G) when fuel tank is full:  
Approximately 105 mm (4.1 in) above top of fuel tank

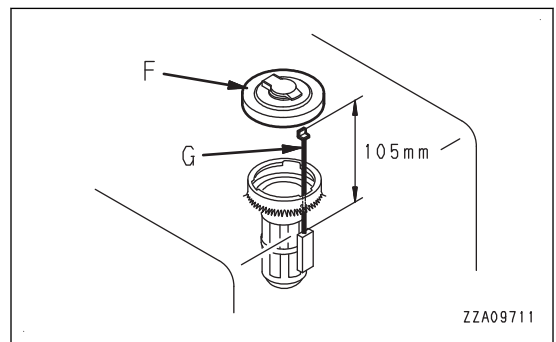

8. After adding fuel, push float gauge (G) straight down with fuel filler cap (F). Be careful not to get float gauge (G) caught in the tab (5) of fuel filler cap (F), and tighten fuel filler cap (F) securely.

**REMARK**

If breather hole (6) in the cap is clogged, the pressure inside the tank will go down and this may cause the fuel to stop flowing. To prevent this, clean the breather hole from time to time.

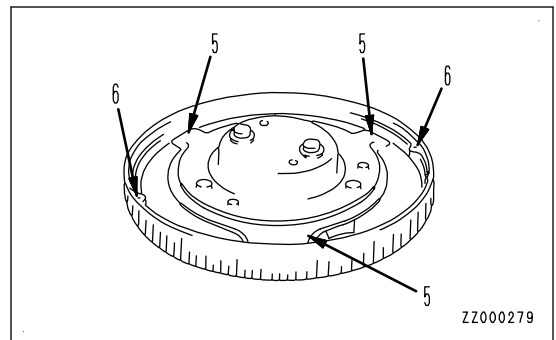

## METHOD FOR CHECKING WORKING LAMP

Check that the working lamps and lamps inside the instruments light up properly. Check also that there is no dirt or damage.

1. Turn the starting switch to ON position.
2. Check that the working lamp lights up properly when the lamp switch is at night mode (a) and at day mode (b).
3. After inspection, turn the lamp switch to OFF position (c), and the working lamp goes out.
4. After checking, turn the starting switch back to OFF position.

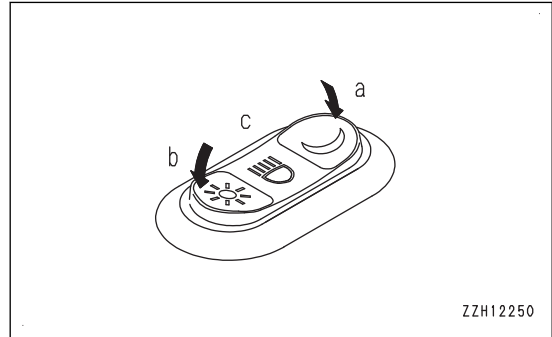

If the lamps do not light up, a broken bulb or disconnected wire are the possible causes. Ask your Komatsu distributor for repairs.

## METHOD FOR CHECKING HORN

1. Turn the starting switch to ON position.
2. Check that the horn sounds immediately when the horn switch is pressed.
3. After checking, turn the starting switch back to OFF position.

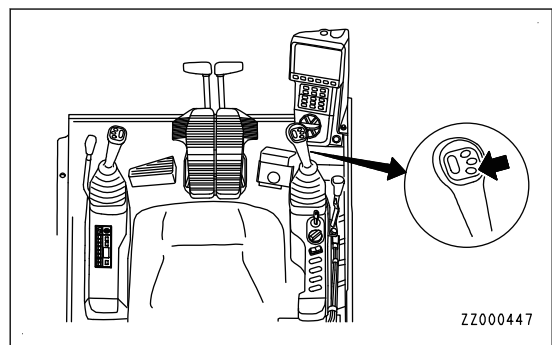

If the horn does not sound, ask your Komatsu distributor for repair.

## METHOD FOR ADJUSTING

### METHOD FOR ADJUSTING OPERATOR'S SEAT

#### **WARNING**

When adjusting the position of the operator's seat, always set the lock lever to **LOCK** position to prevent any accidental contact with the control levers.

- Always adjust the operator's seat before starting each operation or when the operators change shift.
- Adjust the operator's seat so that control levers and switches can be operated freely and easily with the operator's back against the backrest.

#### **Fore-and-aft adjustment of seat**

Pull up fore-aft adjustment lever (1), set the seat to the desired position, then release fore-aft adjustment lever (1).

Fore-and-aft adjustment: 50 mm (2 in) (5 stages)

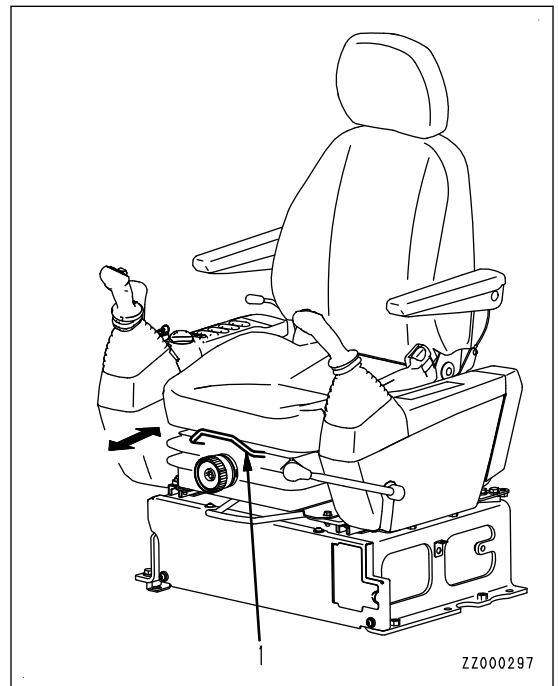



### Reclining adjustment of seat

The seat can be reclined more when the seat is pushed to the front. The amount of reclining decreases as the seat is pushed back, so when moving the seat back, return the backrest to the upright position.

Pull up reclining adjustment lever (2) and set the seat back to a position which is comfortable for operation, then release reclining adjustment lever (2).

**REMARK**

Sit with your back against the backrest when adjusting. If your back is not touching the backrest, it may suddenly move forward.

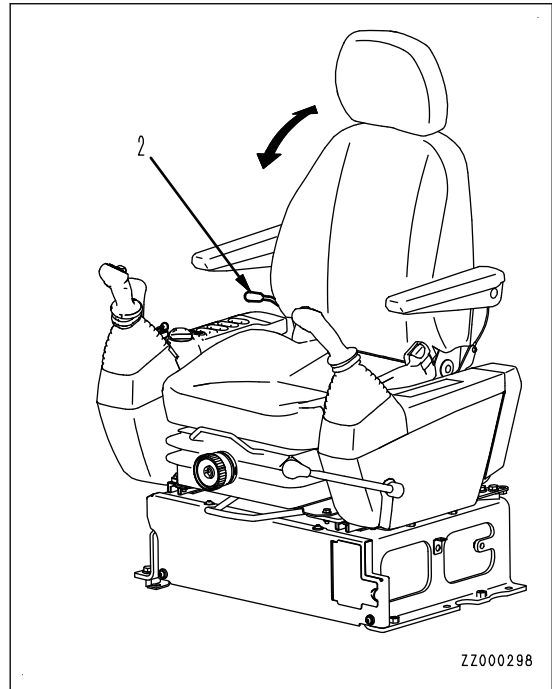

ZZ000298

### Angle adjustment of armrest

- Raise and adjust armrest (3) to a position in the range of approximately 90 deg.
- Finely adjust the vertical angle of the armrest by turning adjustment dial (4) at the bottom of the armrest. If adjustment dial (4) is turned clockwise (counterclockwise), the armrest is raised (lowered).

Amount of angle adjustment: 25 deg.

**REMARK**

If the seat back is tipped to the front without raising armrest (3), armrest (3) rises automatically.

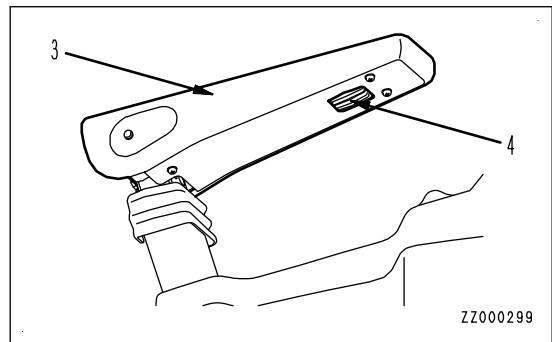

ZZ000299

### Fore-and-aft adjustment of seat unit

Pull fore-aft adjustment lever (5) to the right, adjust the seat to the desired position, then release fore-aft adjustment lever (5). The operator's seat, right and left control levers, and lock lever all slide (move) together.

Fore-and-aft adjustment: 100 mm (3.9 in) (10 stages)

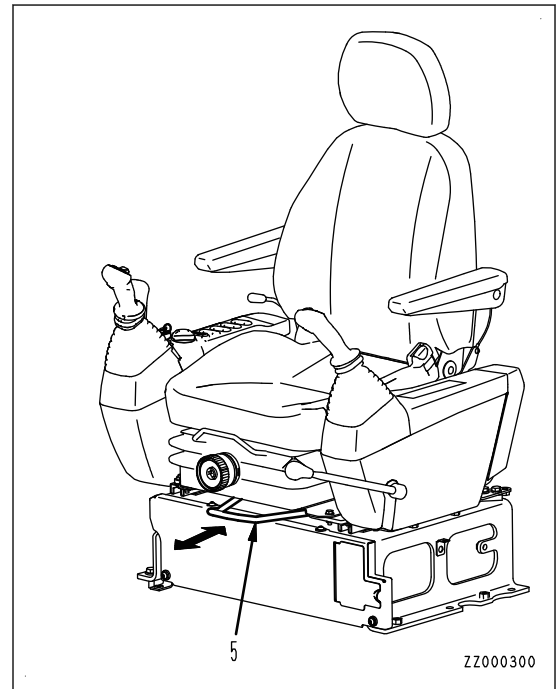

### Hardness adjustment of suspension seat

(for suspension seat)

The figures of weight is indicated on adjustment dial (6). Turn it so that the figure of your weight is at the top.

Weight adjustment range: 60 to 150 kg (132 to 331 lb)

To make the seat softer, adjust the weight to make it lighter; to make the seat harder, adjust the weight to make it heavier.

When traveling on rough road surfaces, make the seat harder before starting operations.

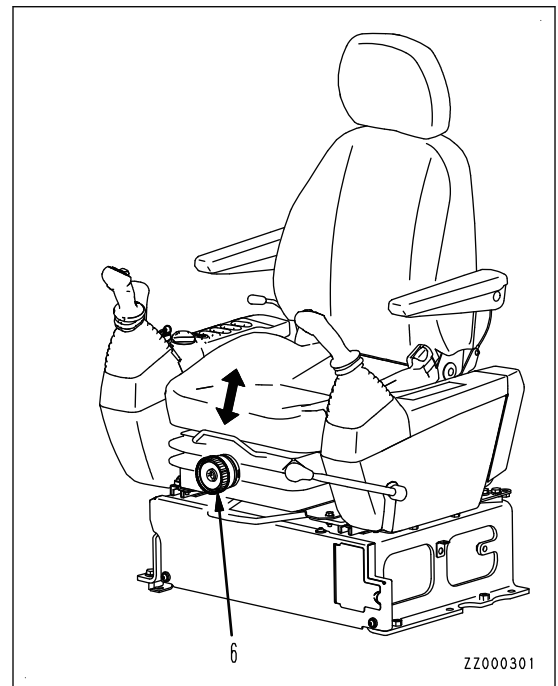

**METHOD FOR ADJUSTING MIRRORS**

**! WARNING**

Be sure to adjust the mirrors before starting work. If they are not adjusted properly, you cannot secure the visibility and may be injured or may lead to serious personal injury or death.

Mirror (A): Machine L.H. front mirror  
 Mirror (B): Machine rear mirror

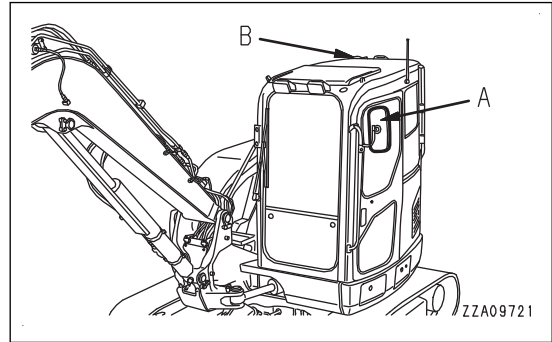

**PROCEDURE FOR ADJUSTING MACHINE LEFT FRONT MIRROR (A)**

**! CAUTION**

Check that the following conditions are satisfied before starting the work to prevent the machine from moving during the work.

- The machine is placed on a level ground.
- The work equipment is lowered to the ground in secure posture.
- The lock lever is in LOCK position.
- The engine is stopped.

Adjust the mirror so that the operator can see a person at the rear left of the machine.

1. If the mirror is removed, install it to the position shown in the figure.  
 (E): 170 mm {6.7 in}  
 Fix mirror securing stay (1) the way the side view mirror stretches outward to the maximum.

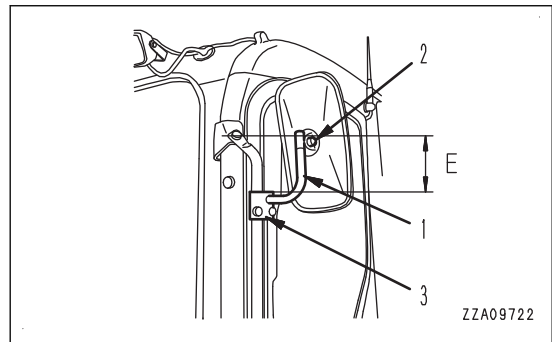

2. Adjust the mirror so that the side of the machine is reflected in the mirror as shown in the figure.  
 If the mirror does not move smoothly when adjusting it, loosen mirror fixing bolt (2) and stay mounting bolt (3).  
 Tightening torque of bolt (2): 15.7 to 19.6 Nm {1.6 to 2.0 kgm, 11.6 to 14.5 lbft}
3. Check that you can see a person at the rear left of the machine.

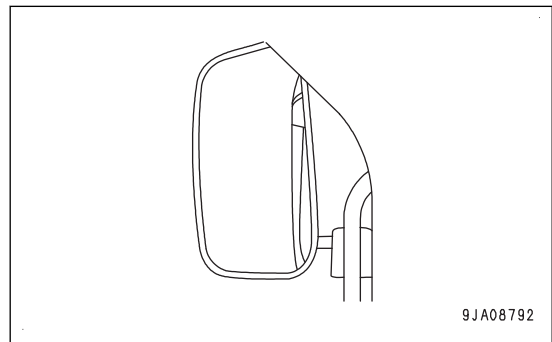

## PROCEDURE FOR ADJUSTING MACHINE REAR MIRROR (B)

### CAUTION

When adjusting the mirror, use a step. If you step on the engine hood, you may fall.

Adjust the mirror so that a person within 1 m (3 ft 3 in) away from around the machine can be seen from the operator's seat.

(J): 1 m (3 ft 3 in)

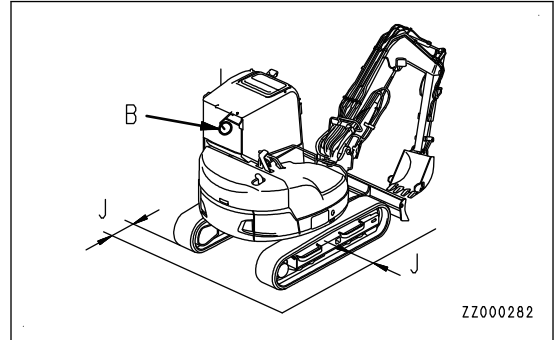

1. Adjust the mirror so that the rear side of the machine is reflected in the mirror as shown in the figure.

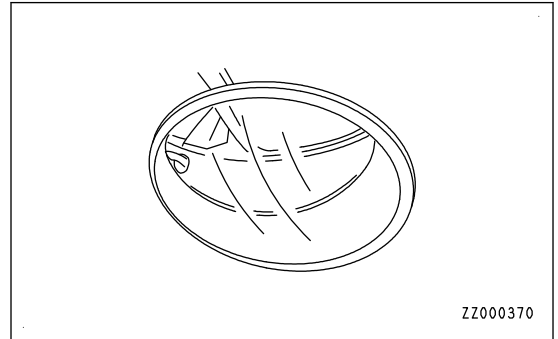

If mirror does not move smoothly when adjusting its angle, loosen mirror fixing bolt (1).

#### Tightening torque of bolt (1)

15.7 to 19.6 Nm {1.6 to 2.0 kgm, 11.6 to 14.5 lbft}

2. Check that you can see a person within 1 m (3 ft 3 in) away from around the machine.

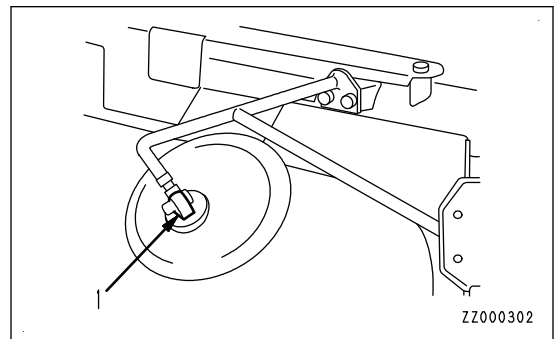

### METHOD FOR ADJUSTING REAR VIEW CAMERA ANGLE

## ⚠ WARNING

- Before starting operation, always check the visibility of the camera. If it is improper, adjust it. If it is not adjusted properly, you cannot secure the visibility and may be injured or may lead to a serious personal injury or death.
- When adjusting the angle of the camera, prepare a scaffold first in order to provide a safe working platform.  
If you try to work standing on the counterweight, there is always a danger of serious injury or death due to falling off from the machine.

Adjust the angle of the rear view camera so that people within 1 m (3 ft 3 in) away from the machine's rear part (W) appears in the machine monitor at the operator's seat.

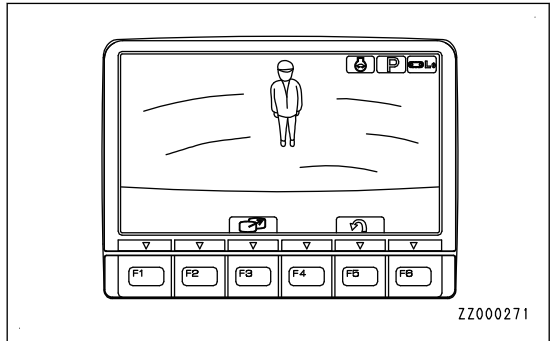
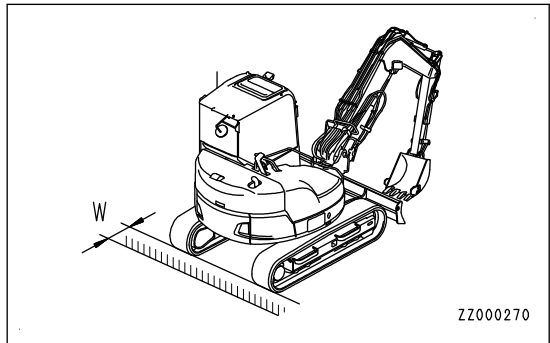
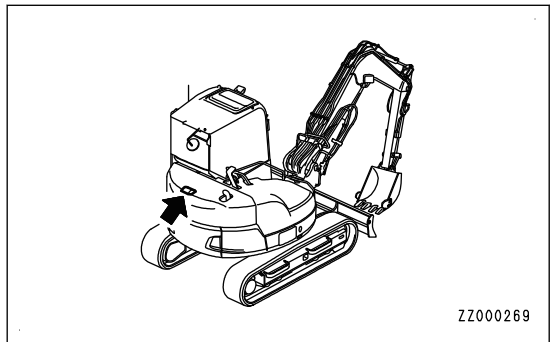

If the image on the monitor is not aligned correctly, adjust mounting angle (A) of the rear view camera in the following procedure.

Angle (A) can be adjusted within the range from 30 to 60 deg.

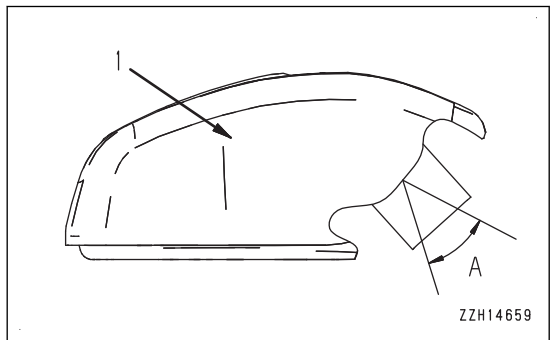

1. Insert a flat-head screwdriver into hole (3) of bolt cover (2) and remove bolt cover (2) while pressing the internal claw.

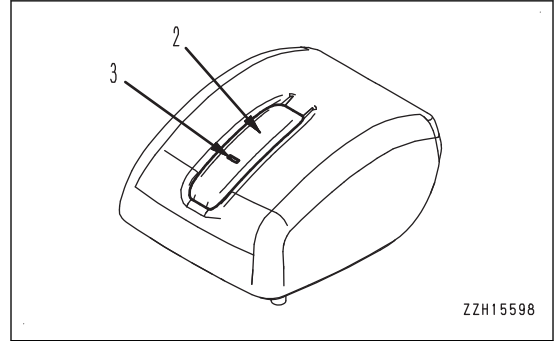

2. Remove bolts (4) (2 places).
3. Remove cover (1).

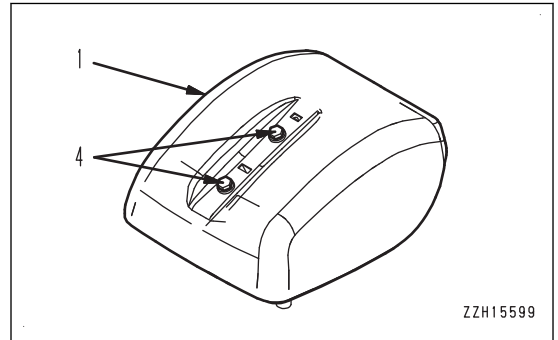

4. Loosen mounting bolts (5) (3 places) of the camera, and adjust camera installing angle (A) so that the side of camera matches the edge of bracket (B).

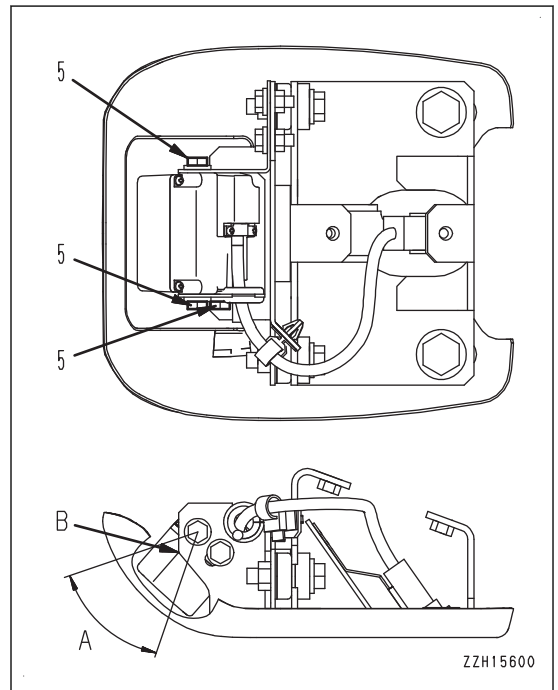

5. After adjusting, tighten bolts (5).  
Tightening: 11.8 to 14.7 Nm {1.2 to 1.5 kgm, 8.68 to 10.8 lbft}

**REMARK**

A part of the machine is shown on the monitor screen.

6. Install covers (1) and (2).

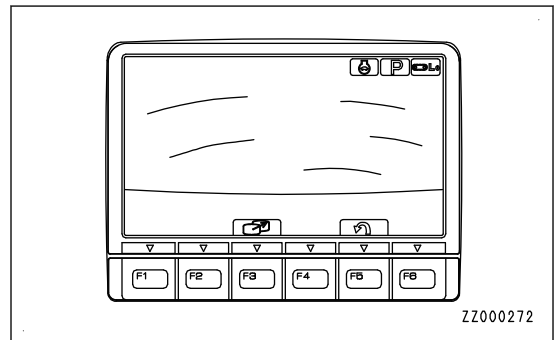

**METHOD FOR FASTENING AND UNFASTENING SEAT BELT**

**⚠ WARNING**

- Before fastening the seat belt, check that there is no problem in the belt mounting bracket or belt. If it is worn or damaged, replace it.
- Even if no problem can be seen in the belt, replace the seat belt every 3 years from starting usage or 5 years after manufacture whichever comes sooner.
- Be sure to use the seat belt during operation.
- Do not use the seat belt if it is twisted.

**REMARK**

- The date of manufacture of the belt is shown on the back of the belt.
- The date indicated on the seat belt is the manufactured date. It is the start of the 5-year period. It is not the start of the 3-year period of actual usage.
- This seat belt has a winding device, so it is not necessary to adjust the length.

**Fasten seat belt**

1. Hold grip (2) and pull out the belt from winding device (1).
2. Check that the belt is not twisted, and then inset tongue (3) into buckle (4) securely.
3. Pull the belt lightly to check that it is properly locked.

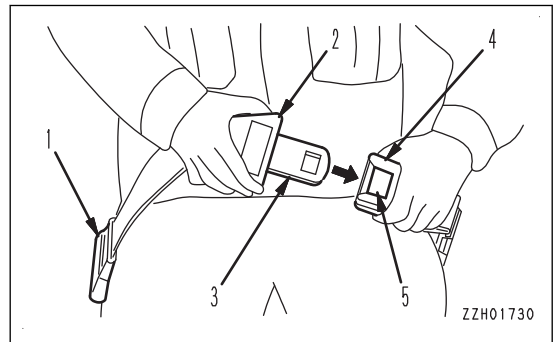

**Unfasten seat belt**

- Press button (5) in buckle (4) and remove tongue (3) from buckle (4).
- Hold grip (2) and slowly return the belt into retractable device (1). The belt retracts automatically.

**REMARK**

If the tongue is not inserted in the buckle, the seat belt caution lamp is displayed at the top left of the monitor. Fasten the seatbelt.

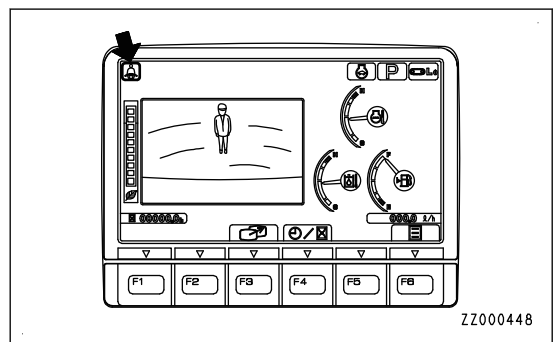

## METHOD FOR OPERATIONS AND CHECKS BEFORE STARTING ENGINE

**⚠ WARNING**

When starting the engine, check that the lock lever is securely at LOCK position.

If the lock lever is not locked securely and the control levers or control pedal are touched when the engine is started, the machine may move unexpectedly, and this may lead to serious personal injury or death.

1. Check that battery disconnect switch (S) is in ON position (I).

2. Check that lock lever (1) is at LOCK position (L).
3. Check that all control levers and control pedals are at NEUTRAL position.

If the control levers and control pedals are not being touched, they will be at NEUTRAL position.

4. Insert the key into starting switch (2) and turn it to ON position (B).

- If a password is set, the input display screen will be indicated on the monitor screen. On the input display screen displayed on the monitor, input the password and push input confirmation switch F6 (3).

**REMARK**

Contact your Komatsu distributor for details of the method of setting, changing, or canceling the password.

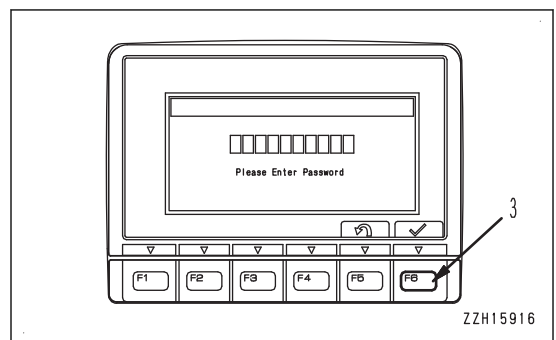
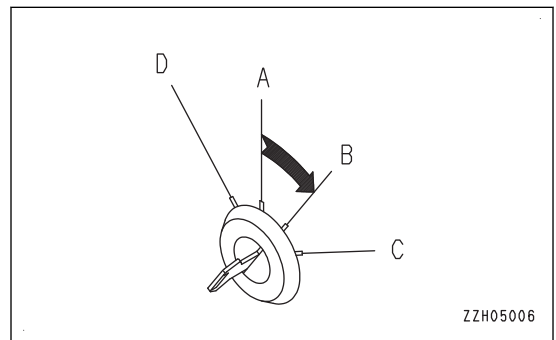
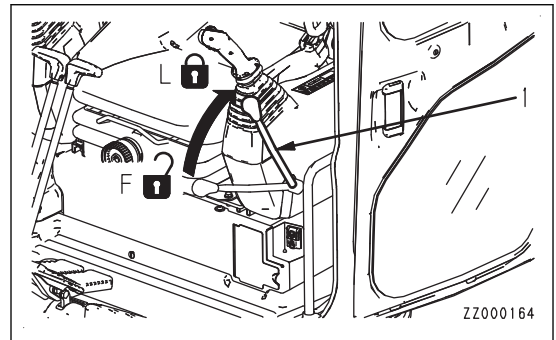
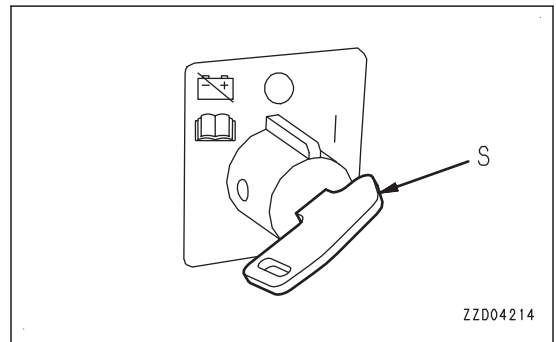
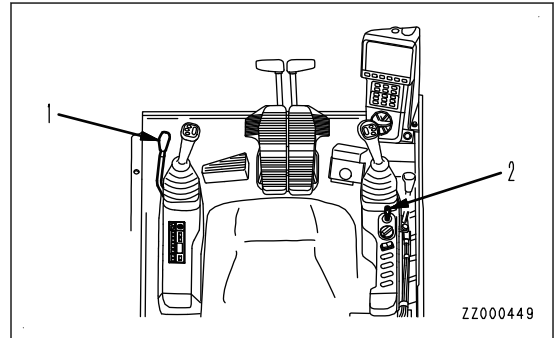



- If inputting ID number for operator identification function (with SKIP) is set, "ID number input" screen is displayed on the monitor when the starting switch is turned to ON position. When "ID number input" screen is displayed on the monitor, input the ID number and press input confirmation switch F6 (3).

**REMARK**

Contact your Komatsu distributor for details of the method of setting, changing, or canceling the operator identification function.

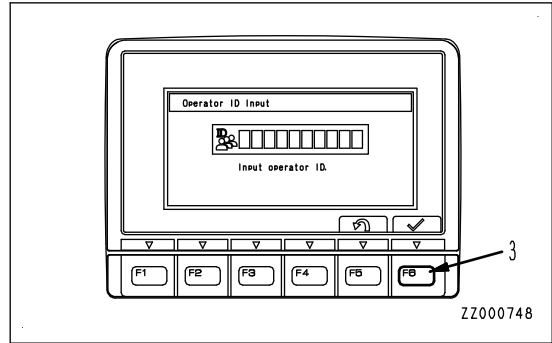

5. Perform the following inspection on the machine monitor.
  - 1) The buzzer sounds for approximately 2 seconds and the following caution lamps light up for approximately 2 seconds.
    - Charge level caution lamp (4)
    - Engine oil pressure caution lamp (5)

If any caution lamp does not light up or the buzzer does not sound, there is probably a failure in the monitor, so ask your Komatsu distributor for repair.

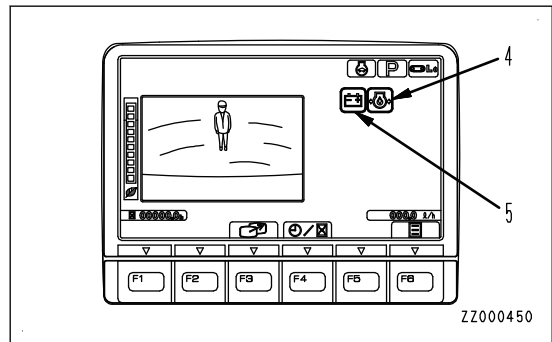

- 2) The screen changes to the working mode and travel speed display screen after approximately 2 seconds, and then it changes to the standard screen.
  - Engine coolant temperature gauge (6)
  - Engine coolant temperature caution lamp (7)
  - Fuel gauge (8)
  - Fuel level caution lamp (9)
  - Hydraulic oil temperature gauge (10)
  - Hydraulic oil temperature caution lamp (11)

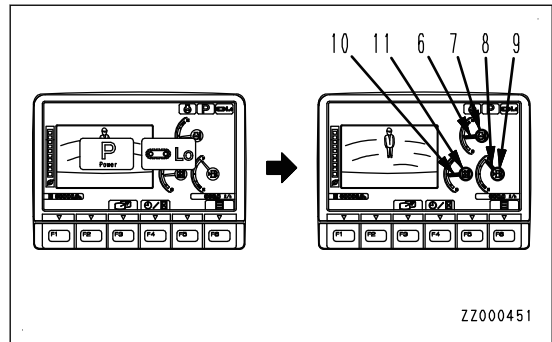

- 3) If the hydraulic oil temperature gauge goes out or caution lamp (12) stays lit in red, immediately check the item lit in red.

For details of contents and check methods for caution lamp, see "CAUTION LAMP LIST".

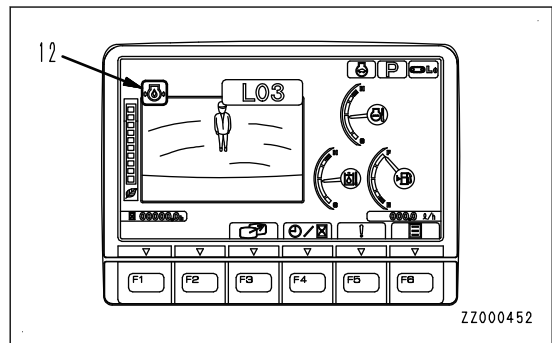

- 4) If the maintenance due time has passed for certain items, maintenance time caution lamp (13) is lit in red for 30 seconds.

- 5) Press user menu display switch (14), check the item which has exceeded the maintenance interval, and perform maintenance immediately.

For details of the method of checking the maintenance interval, see EXPLANATION OF COMPONENTS, "MAINTENANCE SCREEN SETTING".

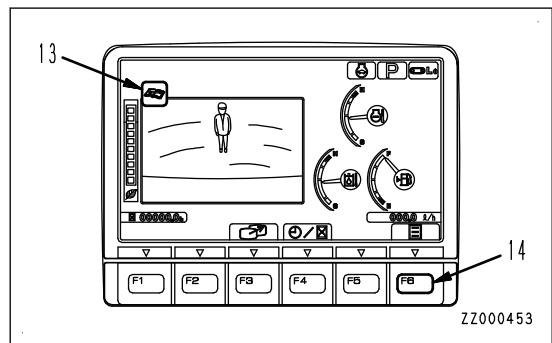

## METHOD FOR STARTING ENGINE

### METHOD FOR STARTING ENGINE IN NORMAL WEATHER

#### WARNING

- Start the engine only while sitting down in the operator's seat.
- Do not attempt to start the engine by short-circuiting the engine starting circuit. Doing so may cause a fire or serious personal injury or death.
- Check that there are no persons or obstacles in the surrounding area, then sound the horn and start the engine.
- Exhaust gas is toxic.  
When starting the engine in confined spaces, be particularly careful to ensure good ventilation.
- Keep the engine hood and covers closed during operation unless you are checking the machine.

#### NOTICE

- Do not start the engine with the fuel control dial near High idle (MAX) position. If you do so, the engine parts may be damaged.
- Do not keep the key in starting switch (3) at the START position continuously for more than 20 seconds. If the engine does not start, wait for 2 minutes or so, and then try to start the engine again.

1. Check that lock lever (1) is at LOCK position (L).  
If lock lever (1) is in FREE position (F), the engine does not start.

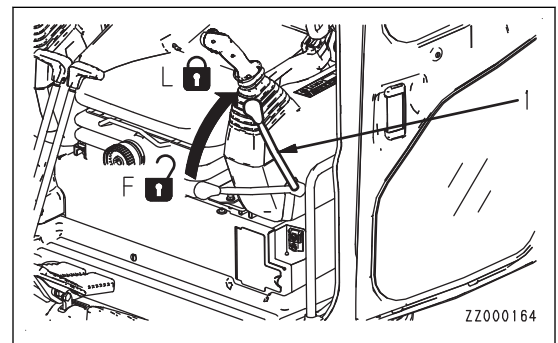
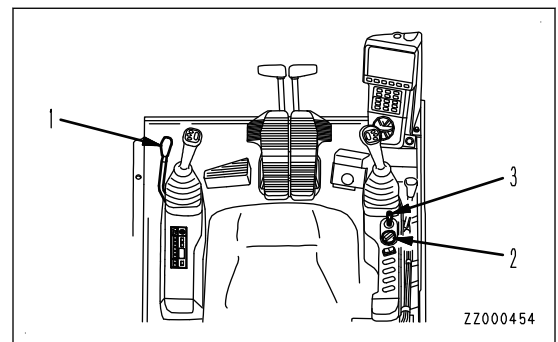

2. Turn fuel control dial (2) to Low idle (MIN) position.

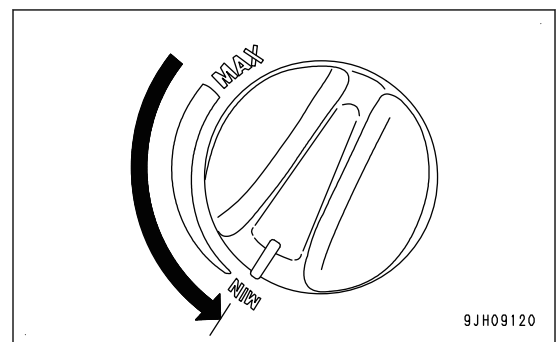

3. Turn starting switch key (3) to START position (C).  
The engine will start.

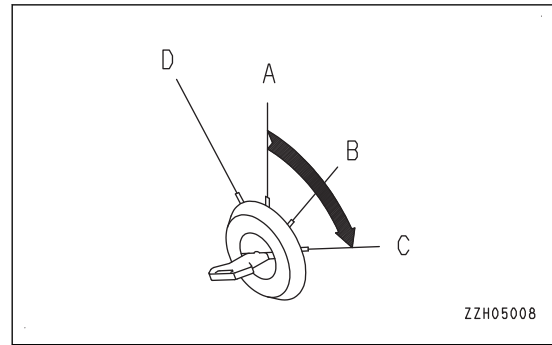

4. When the engine starts, release the starting switch key (3).  
The key will return automatically to ON position (B).

#### REMARK

When the engine is started, the battery voltage may suddenly drop depending on the temperature and the battery condition. If this happens, the display on the machine monitor may momentarily go out, but this does not indicate any abnormality.

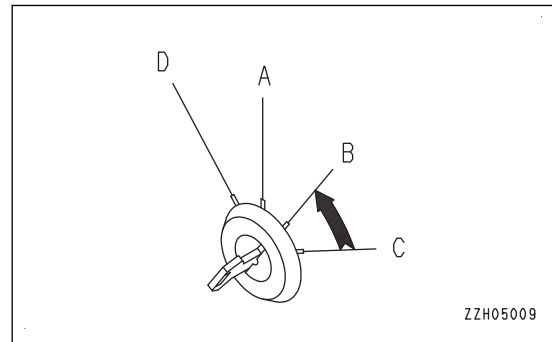

#### NOTICE

- After the engine starts, wait for the engine oil pressure caution lamp to go out. Do not touch the control levers or control pedal while the engine oil pressure caution lamp is lit.
- If the engine oil pressure caution lamp does not go out even after 4 to 5 seconds have passed, stop the engine immediately. Check the oil level, check for leakage of oil, and take the necessary action.

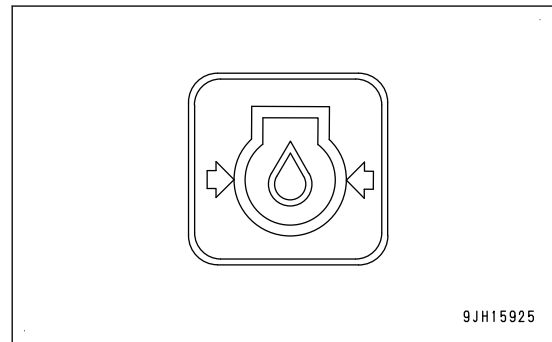

## METHOD FOR STARTING ENGINE IN COLD WEATHER

**⚠ WARNING**

- Start the engine only while sitting down in the operator's seat.
- Do not attempt to start the engine by short-circuiting the engine starting circuit. Doing so may cause a serious personal injury or fire.
- Check that there are no persons or obstacles in the surrounding area, then sound the horn and start the engine.
- Exhaust gas is toxic. When starting the engine in confined spaces, be particularly careful to ensure good ventilation.
- Keep the engine hood and covers closed during operation unless you are checking the machine.

**NOTICE**

- Do not start the engine with the fuel control dial near the maximum speed position. If you do so, the engine parts may be damaged.
- Do not keep the key in starting switch (3) at the START position continuously for more than 20 seconds. If the engine does not start, wait for 2 minutes or so, and then try to start the engine again.

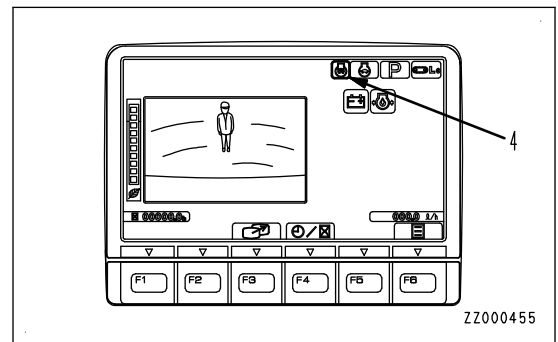
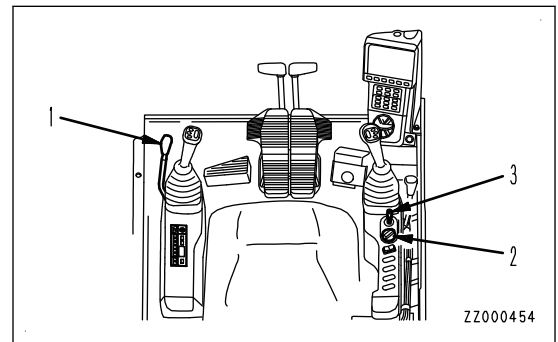

When the ambient temperature is low, start the engine according to the following procedure.

1. Check that lock lever (1) is at LOCK position (L). If lock lever (1) is in FREE position (F), the engine does not start.

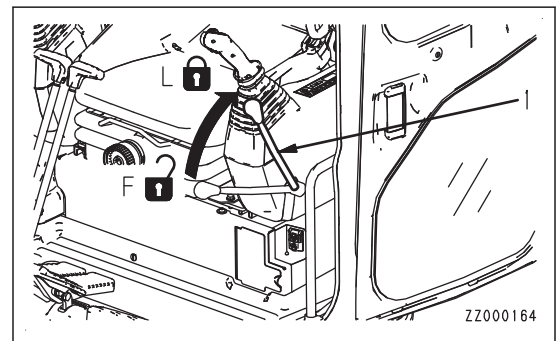

2. Turn fuel control dial (2) to Low idle (MIN) position.

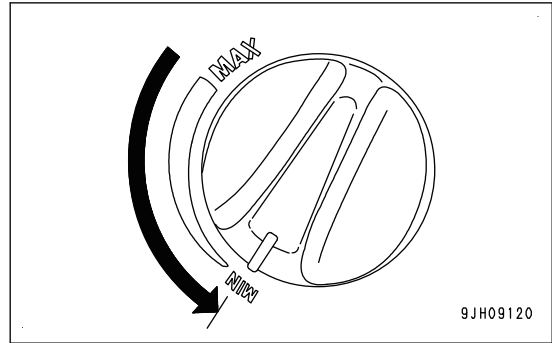

3. Hold starting switch key (3) in HEAT (preheating) position (D).  
Preheating monitor (4) lights up, and after approximately 30 seconds it flashes for 10 seconds to notify completion of preheating.

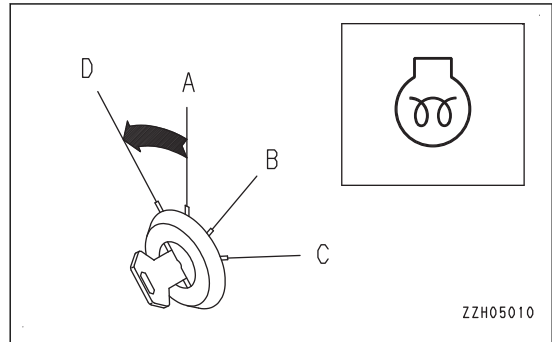

4. After preheating monitor (4) goes out, turn starting switch key (3) to START position (C).  
The engine will start.

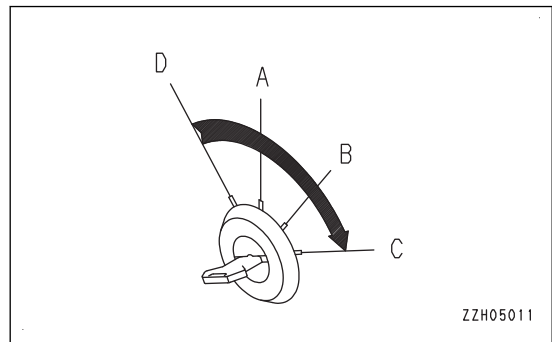

5. When the engine starts, release the starting switch key (3).  
The key will return automatically to ON position (B).

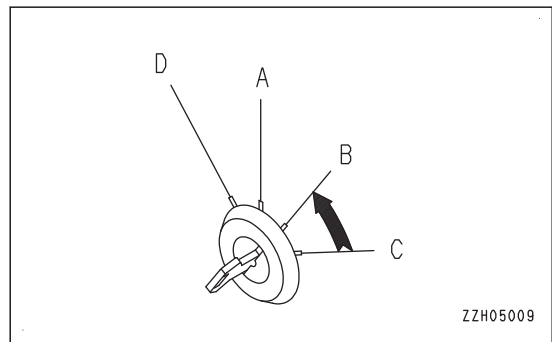

**NOTICE**

- Run the engine at idle for 15 seconds immediately after it started. Do not operate the control levers or fuel control dial during this time.

- After the engine starts, wait for the engine oil pressure caution lamp to go out. Do not touch the control levers or control pedal while the engine oil pressure caution lamp is lit.
- If the engine oil pressure caution lamp does not go out even after 4 to 5 seconds have passed, stop the engine immediately. Check the oil level, check for leakage of oil, and take the necessary action.

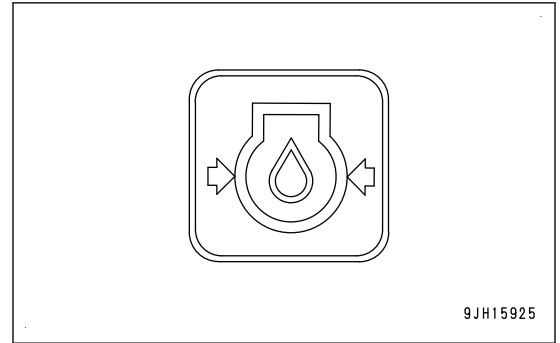

## TURBOCHARGER PROTECTION FUNCTION

The turbo protect function protects the turbocharger by keeping the engine speed at approximately 1,175 rpm or less immediately after the engine is started.

- When the turbo protect function is actuated, the engine speed is held at approximately 1,175 rpm or less, regardless of the position of the fuel control dial.
- When the turbo protect function is actuated, the engine speed is held at approximately 1,175 rpm or less, even if the fuel control dial is operated.
- When the turbo protect function is canceled, the engine speed is set to the speed for the position of the fuel control dial.
- The actuation time of the turbo protect function is limited to 20 seconds.

## METHOD FOR OPERATIONS AND CHECKS AFTER STARTING ENGINE

### WARNING

- If there has been any emergency stop, abnormal actuation or trouble, turn the starting switch key to OFF position.
- Do not perform operations nor operate the levers or pedal abruptly while the hydraulic oil is at low temperature. Always perform the warm-up operation for the hydraulic equipment until the hydraulic oil temperature caution lamp displays the proper temperature. When the hydraulic oil temperature is low, the low temperature display shown in the figure is given.
  - Display (A) when temperature is proper: Caution lamp background (C) is blue.
  - Display (B) when temperature is low: Caution lamp background (C) is white.
- If the warm-up operation for the hydraulic equipment is not performed thoroughly, and the machine is moved, the reaction of the machine to the operation of the control levers and pedals will be slow and the movement of the machine may not be what the operator intended. Always warm up the hydraulic equipment thoroughly in particular in cold environment.
- Keep away from the exhaust pipe immediately while the engine is running and after stopping the engine. Keep combustible materials away from the exhaust pipe outlet.

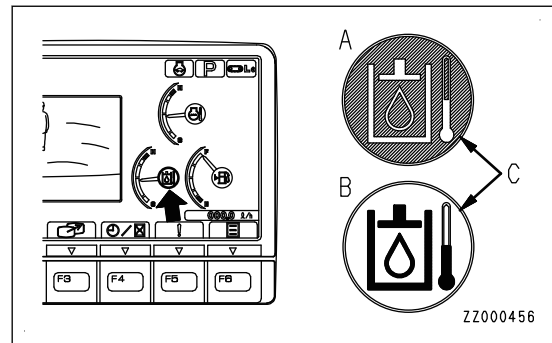

There are 2 types of warm-up operation: warm-up of the engine and warm-up of the hydraulic equipment. In addition, depending on the environment, the method of performing the warm-up operation may differ, so perform the warm-up operation according to the descriptions given in the appropriate section.

The hydraulic equipment is not warmed by simply performing engine warm-up operation. Perform the warm-up operations for the hydraulic equipment and engine separately. Warm-up of the hydraulic equipment thoroughly ensures that the hydraulic oil is warmed up and that warm hydraulic oil circulating in all the control circuits.

## METHOD FOR CHECKING STARTING CONDITION AND UNUSUAL NOISE OF ENGINE

- When starting the engine, check that the engine causes no abnormal noise and that it starts up easily and smoothly.
- Check that there is no abnormal noise when the engine is idling or when the engine speed rises slightly. When there is an abnormal noise at the engine startup and if that condition continues, the engine may be damaged. In that case, ask your Komatsu distributor to check the engine as soon as possible.

## METHOD FOR CHECKING LOW-SPEED RUN AND ACCELERATION OF ENGINE

- When stopping the machine during the normal traveling operation, check that the engine does not hunt or stop suddenly.
- Check that the engine speed rises smoothly when the fuel control dial is turned to High idle (MAX) position.
  - Perform these checks in a safe place, watching out for danger in the surroundings.
  - When the engine performs very badly at low idle and in the acceleration and if that condition continues, it may damage the engine or confuse the operator's sense of driving or lower the braking efficiency, and as a result lead to an unexpected accident. In that case, ask your Komatsu distributor to check the engine as soon as possible.

### REMARK

- The smell of the exhaust gas is different from that of the conventional diesel engine because of the exhaust gas filtering function.
- Black or white smoke may be discharged for a short time just after the engine is started in the cold season, but this is not trouble.

## METHOD FOR RUNNING-IN THE NEW MACHINE

### NOTICE

**Your Komatsu machine has been thoroughly adjusted and tested before shipment from the factory. However, operating the machine under full load before breaking the machine in can adversely affect the performance and shorten the machine life.**

**Be sure to break in the machine for the initial 100 hours (as indicated on the service meter).**

Make sure that you fully understand the descriptions in this manual, then run in the machine while paying attention to the following points.

- Run the engine at idle for 15 seconds immediately after starting it up.  
Do not operate the control levers or fuel control dial during this time.
- Perform warm-up operation for 5 minutes after starting it up.
- Avoid operation with heavy loads or at high speed.
- Immediately after starting the engine, avoid sudden starts, sudden acceleration, unnecessary sudden stops, and sudden changes in direction of the machine.



### METHOD FOR ENGINE WARM-UP OPERATION

**NOTICE**

- Do not accelerate the engine abruptly until it is warmed up.
- Do not run the engine at low idle or high idle under no load for more than 20 minutes. This will have an adverse effect on the environment and also on the internal structure of the engine. If it is necessary to run the engine at idle for 20 minutes or more, apply a load from time to time or run at a mid-range speed.

This machine is equipped with an automatic engine warm-up system, so if the engine coolant temperature is 30 °C (86 °F) or less after the engine is started, the engine warm-up operation starts automatically. When the engine automatic warm-up operation starts, the engine speed is maintained higher than the normal speed at low idle.

If the engine coolant temperature goes 30 °C (86 °F) or more or if the warm-up operation is continued for more than 10 minutes, the automatic warm-up operation is canceled and the engine speed drops to the normal speed at low idle.

Do not start operating the machine immediately. First, perform the following operations and checks.

1. Check that engine coolant temperature caution lamp (1) displays the proper temperature.

If the monitor displays low temperature, perform additional warm-up operation of the engine according to step 2 until it displays the proper temperature.

- Display (A) when temperature is proper: Caution lamp background (C) is blue.
- Display (B) when temperature is low: Caution lamp background (C) is white.

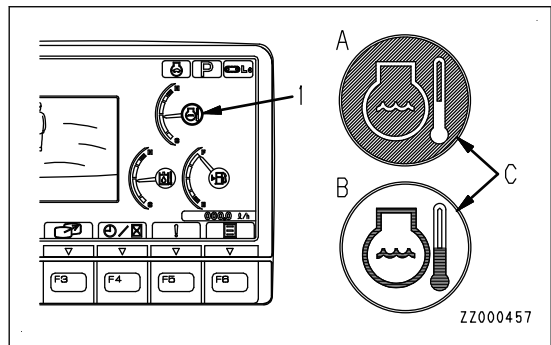

2. Turn fuel control dial (2) to the middle between Low idle (MIN) and High idle (MAX) to run the engine at a medium speed.

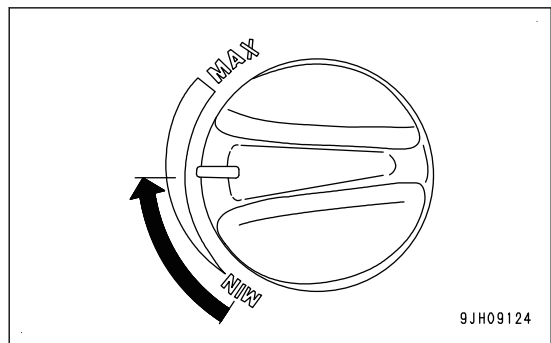
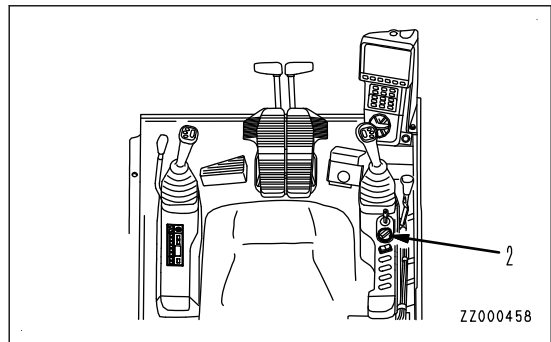

Run the engine with no load until engine coolant temperature caution lamp (1) displays proper temperature.

- Display (A) when temperature is proper: Caution lamp background (C) is blue.
- Display (B) when temperature is low: Caution lamp background (C) is white.

If the engine coolant temperature caution lamp displays the proper temperature, the engine warm-up operation is completed.

Then, perform the warm-up operation for the hydraulic components.

## METHOD FOR CANCELING AUTOMATIC WARM-UP OPERATION

If it becomes necessary in an emergency to cancel the automatic warm-up operation or to lower the engine speed to low idle, do as follows.

1. Turn fuel control dial (2) to High idle (MAX) position and hold it for 3 seconds or more.

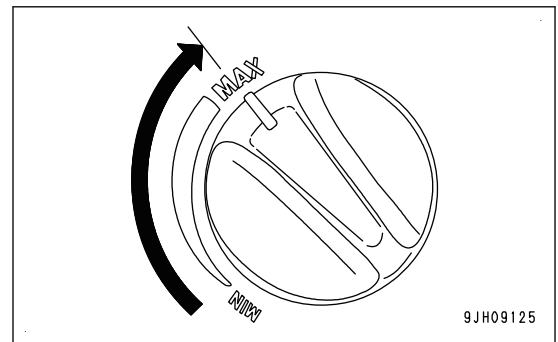
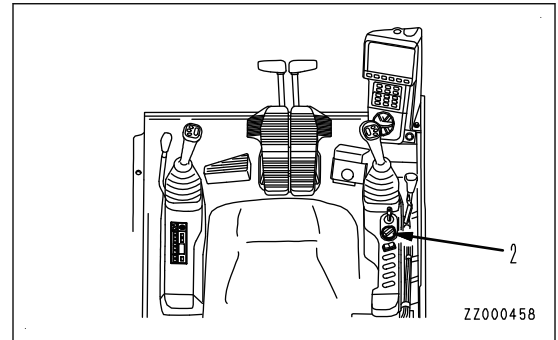

2. Turn fuel control dial (2) to Low idle (MIN) position.  
The engine automatic warm-up is canceled, and the engine speed is lowered.

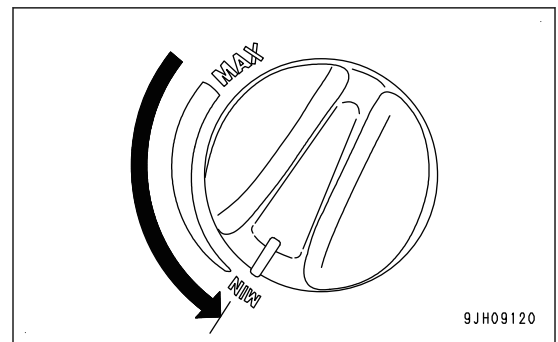

### REMARK

Turbo protect function takes priority over the engine automatic warm-up.

When the turbo protect function activates, run the engine at low idle even the engine coolant temperature is 30 °C {86 °F} or less. Then the engine automatic warm-up starts automatically to increase the engine speed.

METHOD FOR HYDRAULIC SYSTEM WARM-UP OPERATION

**⚠ WARNING**

- When warming up the hydraulic equipment, check that there is no person or obstacle in the surrounding area, then sound the horn and start the operation.
- Perform the warm-up operation for the hydraulic equipment until the hydraulic oil temperature caution lamp displays the proper temperature. When the hydraulic oil temperature is low, the low temperature display shown in the figure is given.
  - Display (A) when temperature is proper: Caution lamp background (C) is blue.
  - Display (B) when temperature is low: Caution lamp background (C) is white.
- The warm-up operation for the hydraulic equipment is necessary not only for the circuit between the pump and cylinders and between the pump and motor, but also for the control circuits. Do not perform the operation just for one cylinder or motor, or the operation just in one direction. Perform the operation in all directions for all the work equipment (boom, arm and bucket), swing, travel, and attachment (if equipped).
- Before operating the travel lever, check the direction of the track frame.

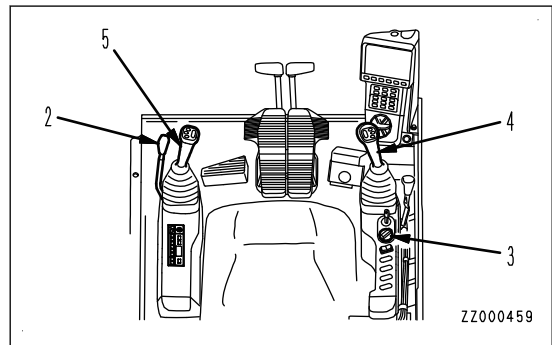
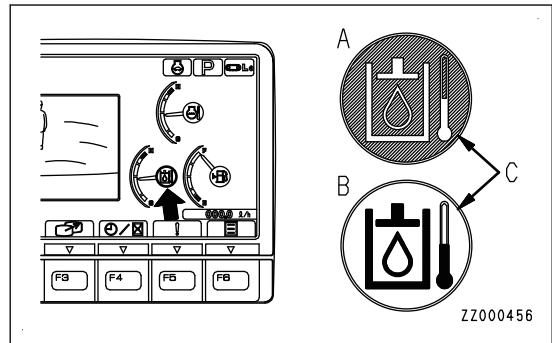

1. Check that engine coolant temperature caution lamp (1) displays the proper temperature.
  - Display (A) when temperature is proper: Caution lamp background (C) is blue.
  - Display (B) when temperature is low: Caution lamp background (C) is white.

If it displays low temperature, perform additional warm up of the engine until engine coolant temperature caution lamp (1) displays the proper temperature.

2. Set the working mode to P mode (heavy-duty operation mode).

Warm up the hydraulic component quickly.

For the details of the working mode setting procedure, see "WORKING MODE SELECTOR SWITCH".

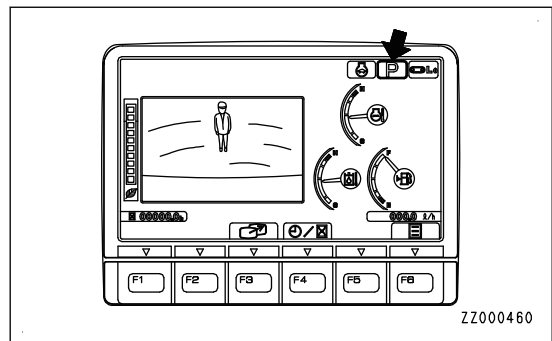
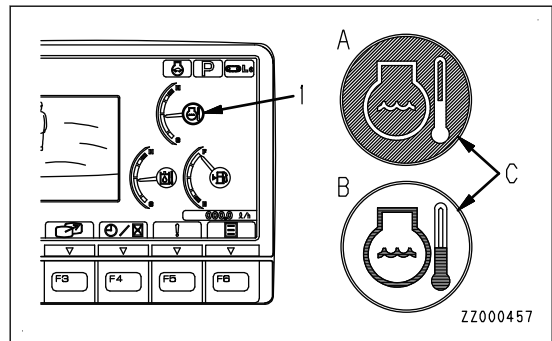

3. Move lock lever (2) slowly to FREE position (F).
4. Raise the bucket from the ground.

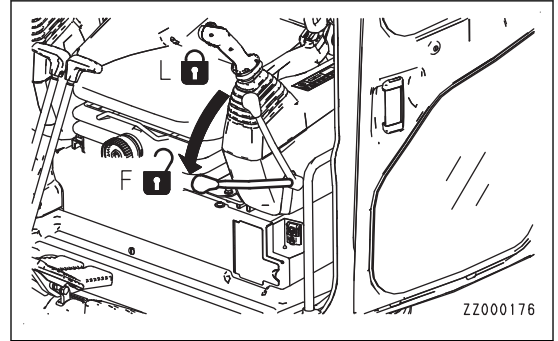

5. Turn fuel control dial (3) to a point of 2/3 between Low idle (MIN) and High idle (MAX).

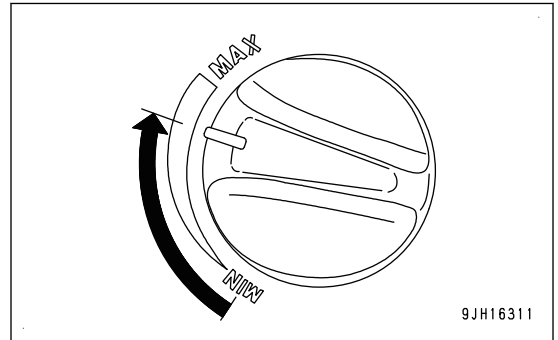

6. Operate the work equipment to warm up the hydraulic components.

**NOTICE**

**When the work equipment is operated, take care that it does not interfere with the machine or ground.**

- 1) Move right work equipment control lever (4) slowly in the direction to pull in bucket (D). Operate the lever to the end of its travel and hold it in position for 30 seconds.
- 2) Move right work equipment control lever (4) slowly in the direction to push out bucket (C). Operate the lever to the end of its travel and hold it in position for 30 seconds.
- 3) Next, move left work equipment control lever (5) slowly in the direction to pull in arm (B). Operate the lever to the end of its travel and hold it in position for 30 seconds.
- 4) Move left work equipment control lever (5) slowly in the direction to push out arm (A). Operate the lever to the end of its travel and hold it in position for 30 seconds.

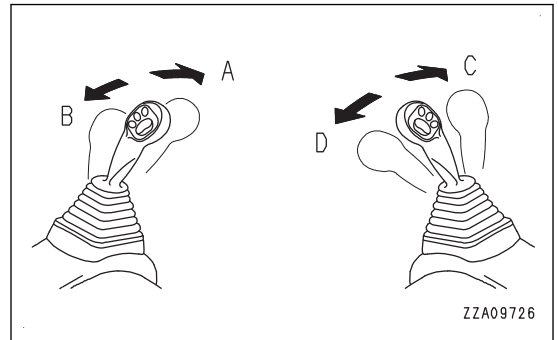

7. Repeat the operation of step 6 for 5 minutes.
8. Check that hydraulic oil temperature caution lamp (6) displays proper temperature.

- Display (A) when temperature is proper: Caution lamp background (C) is blue.
- Display (B) when temperature is low: Caution lamp background (C) is white.

If hydraulic oil temperature caution lamp (6) displays low temperature, repeat steps 6 to 10 until the lamp displays the proper temperature.

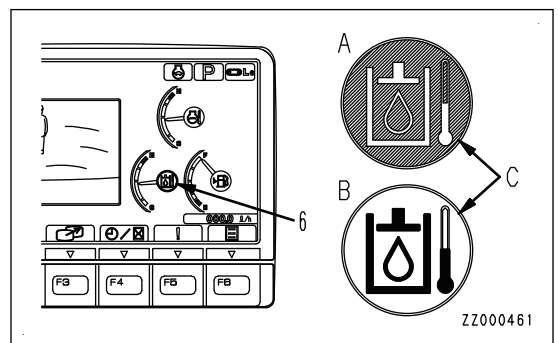

9. Check that engine coolant temperature caution lamp (1) displays the proper temperature.

- Display (A) when temperature is proper: Caution lamp background (C) is blue.
- Display (B) when temperature is low: Caution lamp background (C) is white.

If engine coolant temperature caution lamp (1) displays low temperature, perform warm-up operation until the proper temperature is displayed.

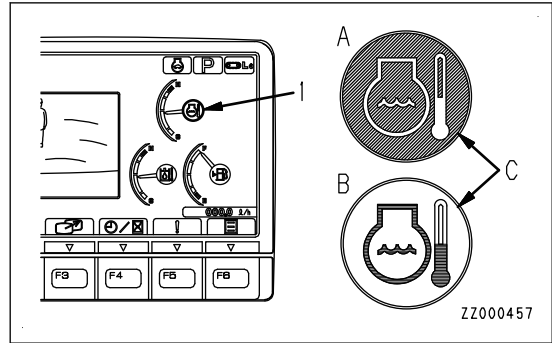

10. Check that hydraulic oil temperature caution lamp (6) and engine coolant temperature caution lamp (1) display the proper temperature, then check that all the caution lamps, pilot lamps, and gauges on the machine monitor are in the following conditions.

- Charge level caution lamp (7): OFF
- Engine oil pressure caution lamp (8): OFF
- Engine preheating pilot lamp (9): OFF
- Engine coolant temperature gauge (10): Indicator in green range
- Engine coolant temperature caution lamp (1): Displays proper temperature
- Hydraulic oil temperature gauge (11): Indicator in green range
- Hydraulic oil temperature caution lamp (6): Displays proper temperature
- Fuel gauge (12): Indicator in green range
- Fuel level caution lamp (13): Displays appropriate level

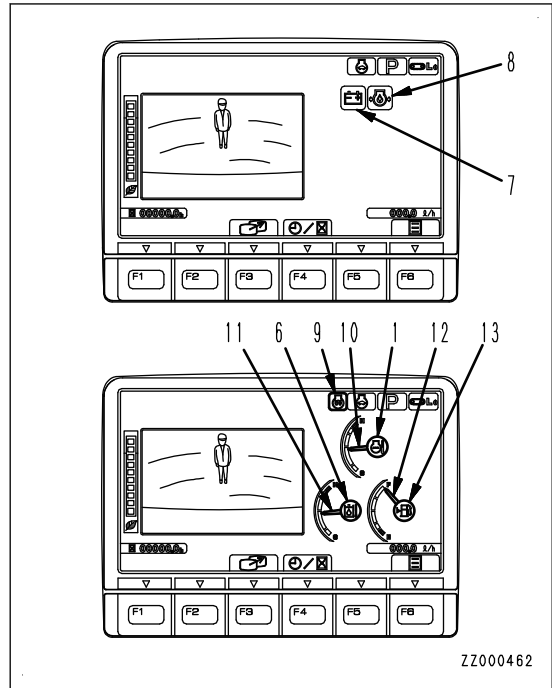

11. Check for abnormal exhaust gas color, noise, or vibration. If any problem is found, contact your Komatsu distributor.

12. Hydraulic system warm-up operation in cold weather

**NOTICE**

**In cold temperatures (ambient temperature below 0 °C {32 °F} ), even when the hydraulic oil temperature caution lamp displays the proper temperature, perform the "warm-up operation for hydraulic equipment in cold temperatures" to warm up all the hydraulic equipment.**

- 1) Turn fuel control dial (3) to the High idle (MAX) position.

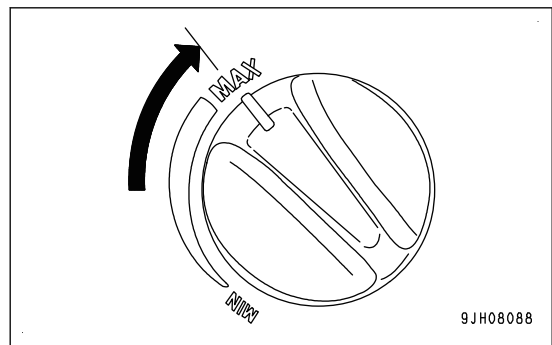

2) Repeat the work equipment operation of step 6 for 3 to 5 minutes.

3) Check that hydraulic oil temperature caution lamp (6) displays proper temperature.

- Display (A) when temperature is proper: Caution lamp background (C) is blue.
- Display (B) when temperature is low: Caution lamp background (C) is white.

If hydraulic oil temperature caution lamp (6) is displaying low temperature, repeat step 2) until the monitor displays the proper temperature.

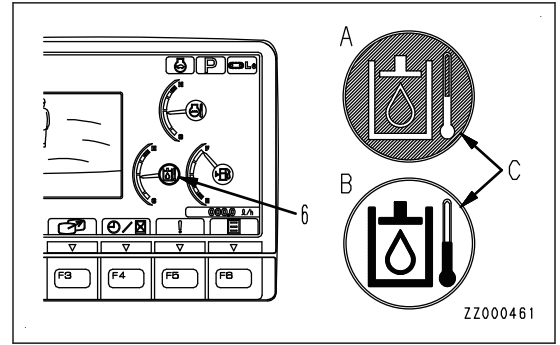

13. Before starting the work, check that fuel control dial (3) is at a point of 2/3 between Low idle (MIN) and High idle (MAX).

If it is not at the 2/3 point, set it to the 2/3 point and run the engine at 2/3 speed between MIN and MAX before operating.

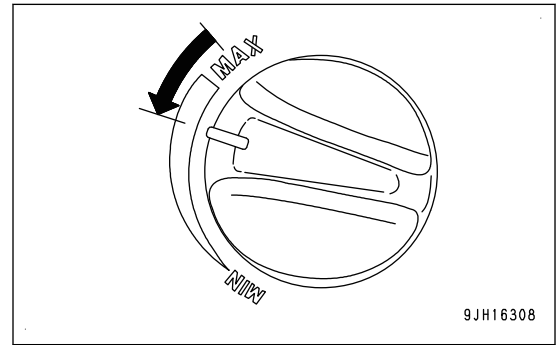

14. Before starting actual operations, repeat the following operations slowly 3 to 5 times to circulate warm oil through the all control circuits.

- |                |                          |
|----------------|--------------------------|
| Boom control   | RAISE (E) <--> LOWER (F) |
| Arm control    | IN (B) <--> OUT (A)      |
| Bucket control | CURL (D) <--> DUMP (C)   |
| Swing control  | LEFT (G) <--> RIGHT (H)  |

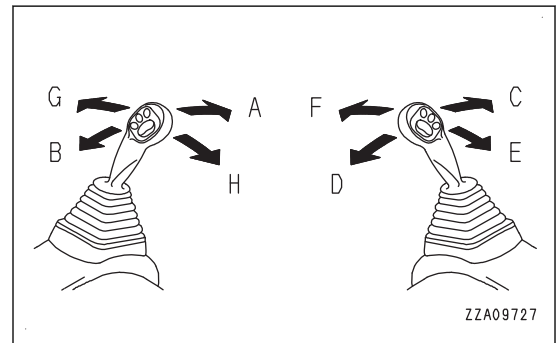

- |                     |                              |
|---------------------|------------------------------|
| Travel (Lo) control | FORWARD (A) <--> REVERSE (B) |
|---------------------|------------------------------|

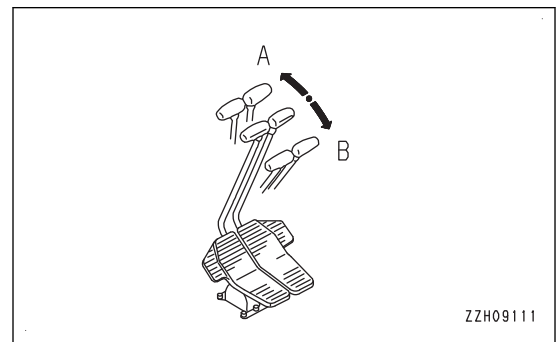

Boom swing control

You can swing the boom with the boom swing control pedal.

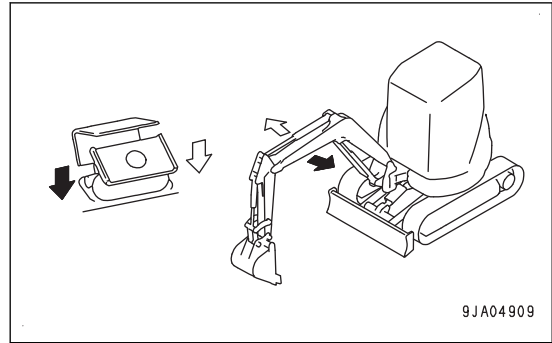

Blade control

LOWER (a) <--> RAISE (b)

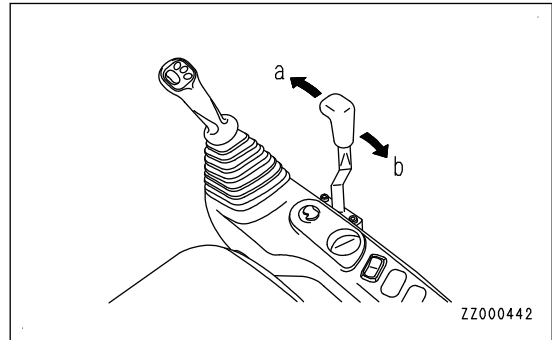

Attachment control

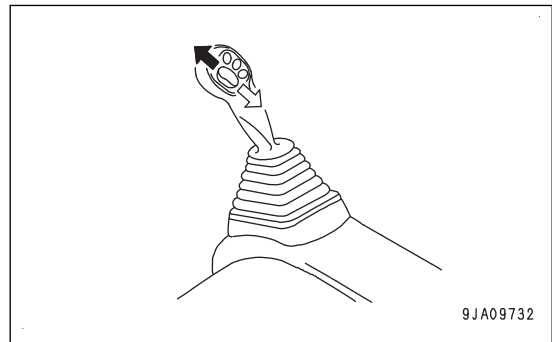

For attachment operations (if equipped), change the working mode to the attachment mode.

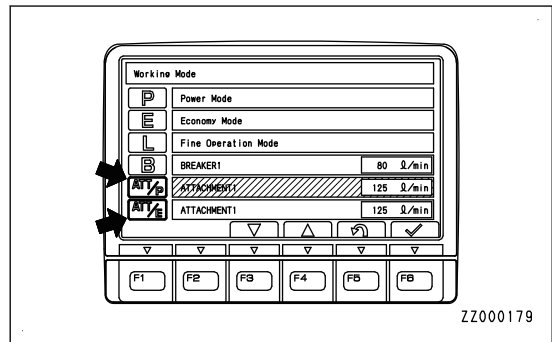

15. Check that hydraulic oil temperature caution lamp (6) displays proper temperature.

- Display (A) when temperature is proper: Caution lamp background (C) is blue.
- Display (B) when temperature is low: Caution lamp background (C) is white.

If the caution lamp is not displaying the proper temperature, repeat the work equipment operation in step 6) until the lamp displays the proper temperature.

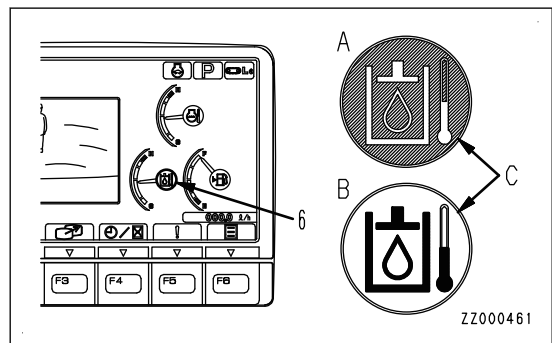

If hydraulic oil temperature caution lamp (6) displays the proper temperature, the hydraulic equipment warm-up operation is completed.

After checking that hydraulic oil temperature caution lamp (6) displays the proper temperature, perform the operation after completion of the warm-up operation.

**METHOD FOR OPERATION AFTER COMPLETION OF WARM-UP OPERATION**

1. Check that hydraulic oil temperature caution lamp (6) displays proper temperature.

Display (A) when temperature is proper: Caution lamp background (C) is blue.

Display (B) when temperature is low: Caution lamp background (C) is white.

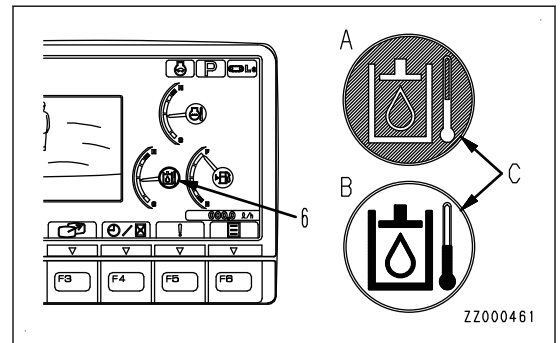

ZZ000461

2. Press the working mode selector switch of the machine monitor to select the working mode to be used.

For change of the working mode, see "WORKING MODE SELECTOR SWITCH".

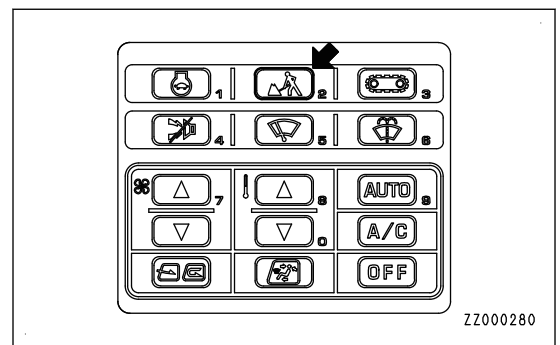

ZZ000280



Display of working mode

P mode

For heavy-duty operations

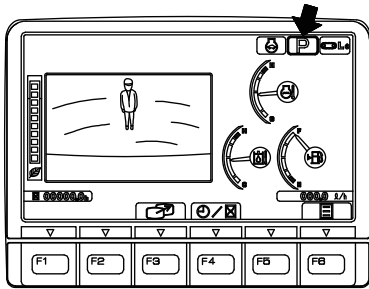

ZZ000460

E mode

For fuel economy conscious operations

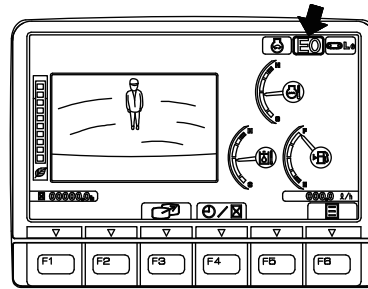

ZZ000463

L mode

For operations requiring fine control

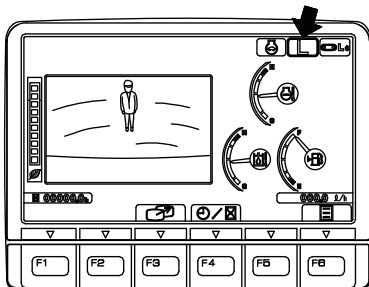

ZZ000464

B mode

For breaker operations

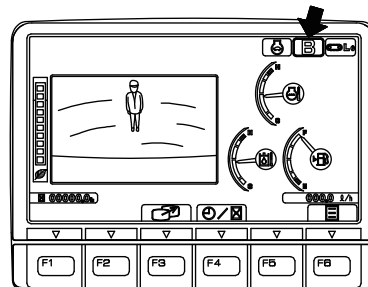

ZZ000465

ATT/P mode

For operations of 2-way attachment such as crusher

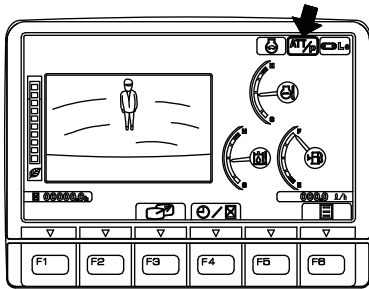

ZZ000466

ATT/E mode

For operations of 2-way attachment such as crusher  
(fuel economy conscious operations)

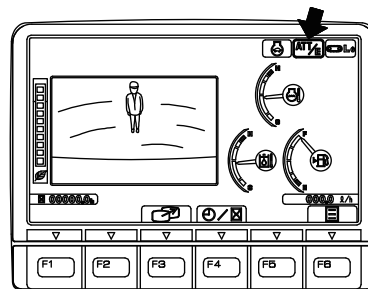

ZZ000467

## METHOD FOR STOPPING ENGINE

### WARNING

Keep away from the exhaust pipe immediately after stopping the engine.

#### NOTICE

If the engine is stopped abruptly, the service lives of component parts of the engine may be considerably reduced. Do not stop the engine abruptly except in an emergency. Do not stop the engine abruptly except the case in an emergency. If the engine is overheated, do not try to stop it abruptly but run it at medium speed to allow it to cool down gradually, and then stop it.

Stop the engine according to the following procedure.

1. Run the engine at low idle for approximately 5 minutes to cool it down gradually.
2. Turn the key in starting switch (1) to OFF position (A).  
The engine will stop.
3. Remove the key from starting switch (1).

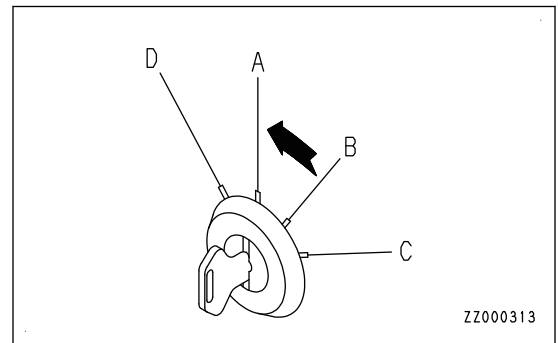
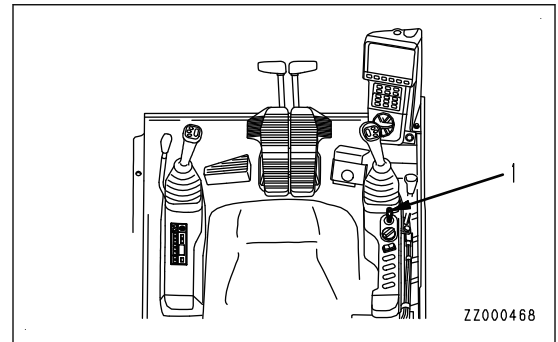

## METHOD FOR STARTING MACHINE (TRAVEL FORWARD AND REVERSE) AND STOPPING MACHINE

### WARNING

- Before operating the travel levers or travel pedals, check the direction of the track frame.  
If the track frame is facing the rear (if the sprocket is at the front), the machine moves in the opposite direction to the direction of the operation of the travel levers or travel pedals (front and rear travel are reversed, left and right steering are reversed).
- Check that the area around the machine is safe, sound the horn before starting the machine.
- Prohibit anyone other than the operator from coming close to the machine during operation.
- Clear any obstacles from the travel path.
- If the travel levers or travel pedals are operated when the engine speed is decreased by the auto-deceleration function, the engine speed will suddenly increase. Operate the levers carefully.
- When traveling, check that the alarm sounds normally.

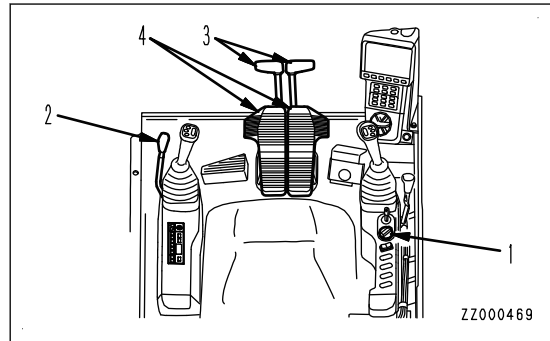

### PREPARATIONS FOR MOVING MACHINE

Prepare for moving the machine according to the following procedure.

Turn fuel control dial (1) to High idle (MAX) position.  
The engine speed increases.

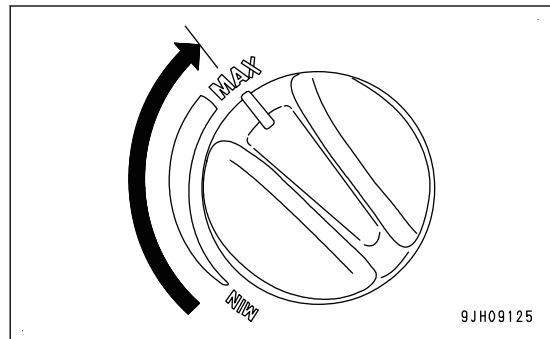

## METHOD FOR TRAVELING FORWARD

1. Set lock lever (2) to FREE position (F).
2. Set the work equipment in the travel posture and raise it to height "a".  
a: 40 to 50 cm (16 to 20 in)
3. Raise the blade.

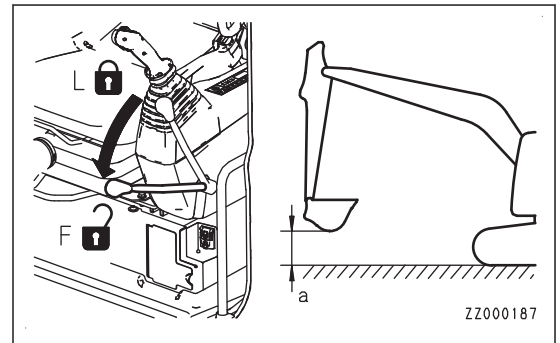

4. Operate right and left travel levers (3) or right and left travel pedals (4) as follows:

- When sprocket (A) is at the rear of the machine:

Start the machine either by pushing right and left travel levers (3) forward slowly or by depressing the front parts of right and left travel pedals (4) slowly.

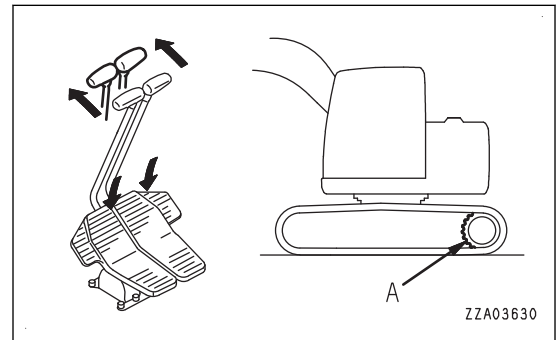

- When sprocket (A) is at the front of the machine:

Start the machine either by pulling right and left travel levers (3) backwards slowly or by depressing the rear parts of right and left travel pedals (4) slowly.

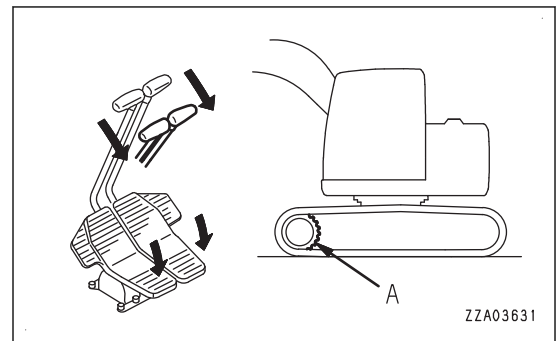

5. When traveling, check that the alarm sounds normally.

If the travel alarm does not sound, contact your Komatsu distributor for repair.

### REMARK

In low temperatures, if the machine travel speed is not normal, thoroughly perform the warming-up operation.

In addition, if the undercarriage is packed with mud and the machine travel speed is not normal, remove the soil and mud from the undercarriage.

## METHOD FOR TRAVELING REVERSE

1. Set lock lever (2) to FREE position (F).
2. Set the work equipment in the travel posture and raise it to height "a".  
a: 40 to 50 cm (16 to 20 in)
3. Raise the blade.

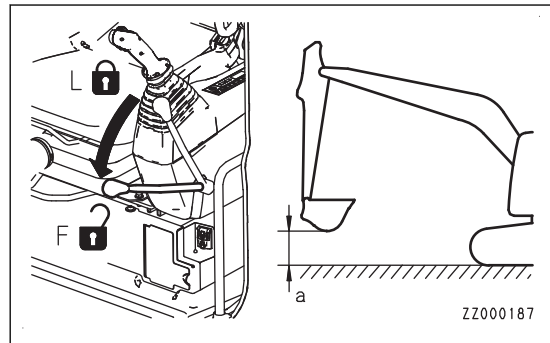

4. Operate right and left travel levers (3) or right and left travel pedals (4) as follows:

- When sprocket (A) is at the rear of the machine:  
Start the machine either by pulling levers (3) backwards slowly or by depressing the rear parts of pedals (4) slowly.

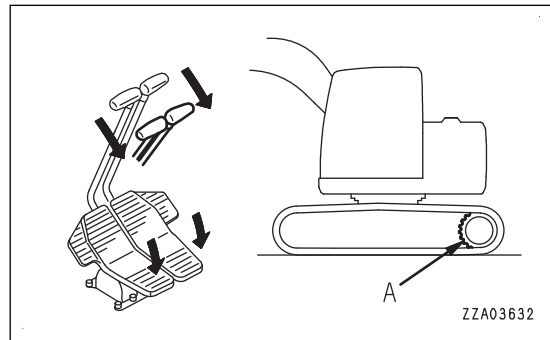

- When sprocket (A) is at the front of the machine:  
Start the machine either by pushing levers (3) forward slowly or by depressing the front parts of pedals (4) slowly.

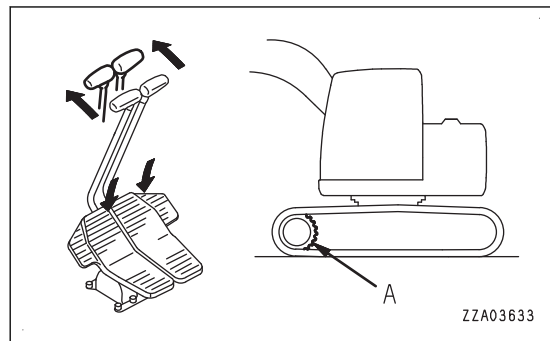

5. When traveling, check that the alarm sounds normally.  
If the travel alarm does not sound, contact your Komatsu distributor for repair.

### REMARK

In low temperatures, if the machine travel speed is not normal, thoroughly perform the warming-up operation.

In addition, if the undercarriage is packed with mud and the machine travel speed is not normal, remove the soil and mud from the undercarriage.

## METHOD FOR STOPPING MACHINE

Avoid a sudden stop. Stop the machine gradually.

Set right and left travel levers (3) in NEUTRAL position (N).

The machine stops.

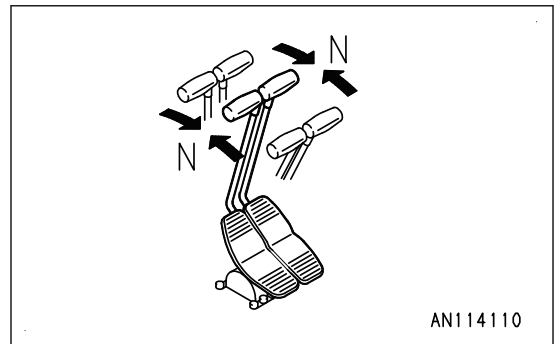
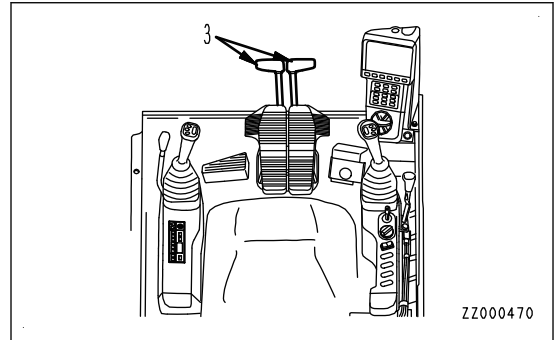

### METHOD FOR STEERING MACHINE

### METHOD FOR STEERING (CHANGE THE DIRECTION) MACHINE

## ⚠ WARNING

Before operating the travel levers or travel pedals, check the direction that the track frame is facing (the position of the sprocket).

When the sprocket is at the front, the directions of operations of the travel levers or control pedals are the opposite to the direction of movement of the machine.

Use the travel levers to change direction.

Avoid sudden changes of direction to travel as much as possible. Especially when performing counter-rotation turn (spin turn), stop the machine before turning.

Operate 2 travel levers (1) as follows.

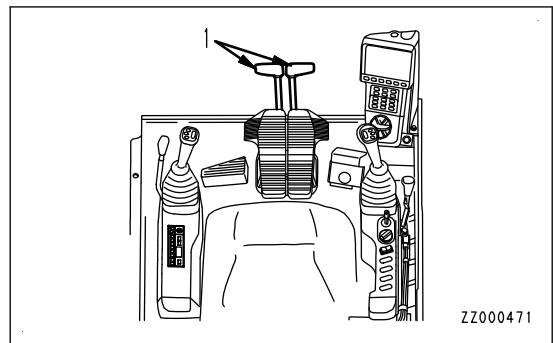

### PIVOT TURN

When turning forward left, push the right travel lever forward.

When turning reverse left, pull the right travel lever backward.

(A): Forward left turn

(B): Reverse left turn

### REMARK

When turning right, operate the left travel lever in the same way.

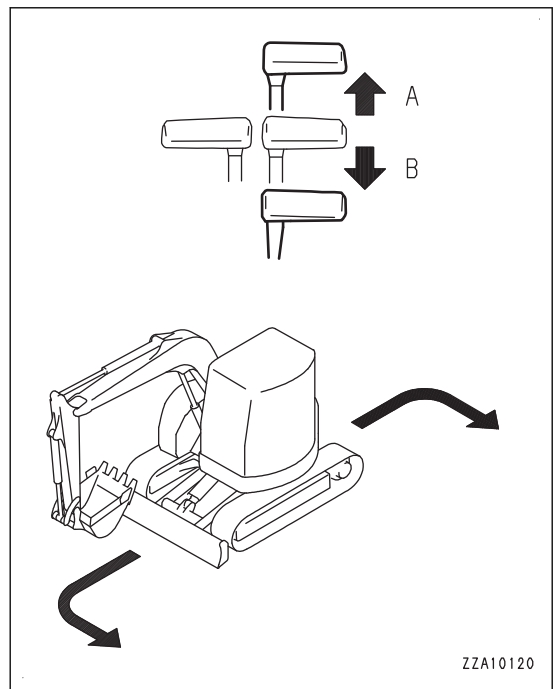

**CHANGE DIRECTION OF MACHINE**

When turning left, return the left travel lever to the neutral position.

(A): Forward left turn

(B): Reverse left turn

**REMARK**

When turning to the right, operate the right travel lever in the same way.

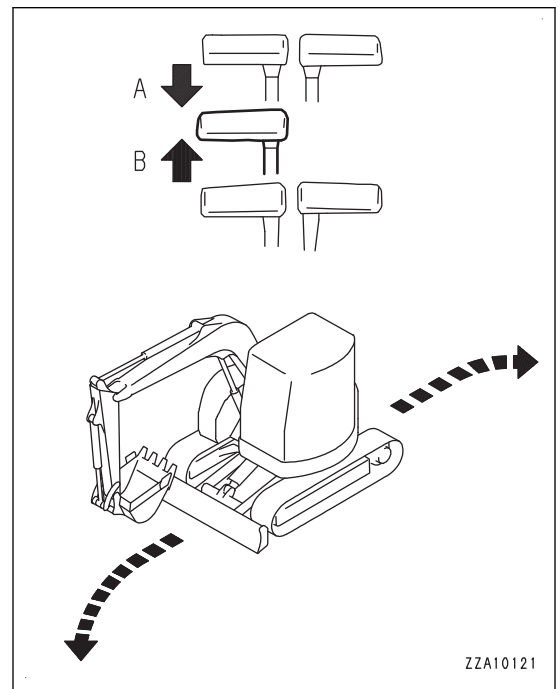
**COUNTER-ROTATION TURN (SPIN TURN)**

When performing counter-rotation turn (spin turn) to the left, pull the left travel lever backward and push the right travel lever forward.

**REMARK**

When performing counter-rotation turn to the right, pull the right travel lever backward and push the left travel lever forward.

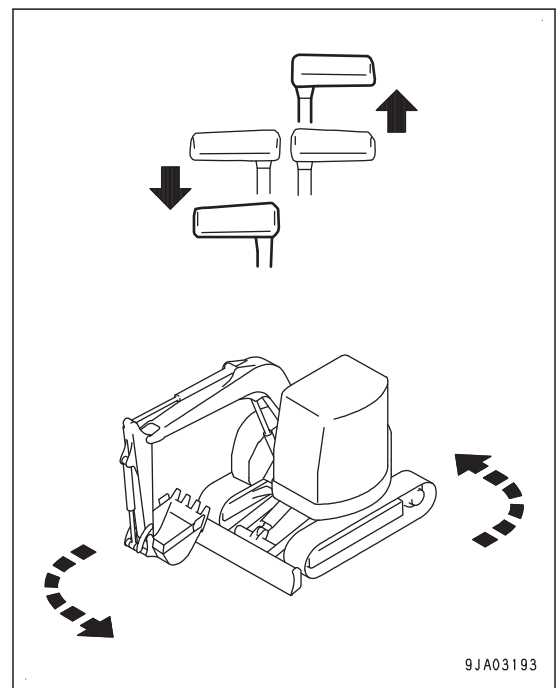



### METHOD FOR SWINGING MACHINE

#### **! WARNING**

- The tail of the machine extends outside the tracks. Before swinging, check safety around the machine by using the mirrors and visually.
- If the travel levers or travel pedals are operated when the engine speed is decreased by the auto-deceleration function, the engine speed will suddenly increase. Operate the levers carefully.

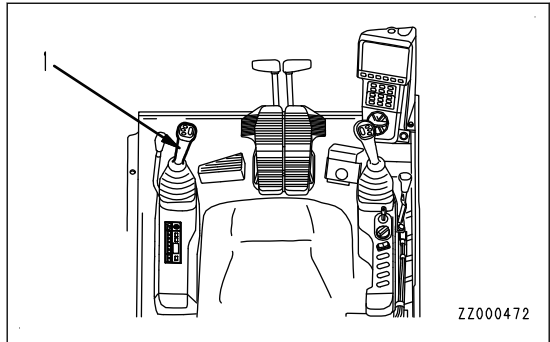

- Operate L.H. work equipment control lever (1) to swing the upper structure.
  - (A): Swing LEFT
  - (B): Swing RIGHT
- When you do not swing the upper structure, set L.H. work equipment control lever (1) to N (neutral) position. The swing brake is applied.

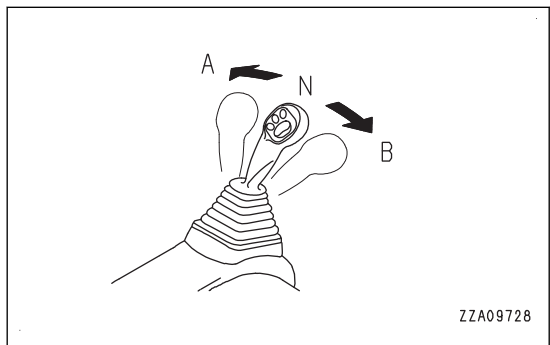

### METHOD FOR OPERATING WORK EQUIPMENT

#### **! WARNING**

- For control patterns other than the standard control method (ISO pattern), see ATTACHMENTS AND OPTIONS.
- If the travel levers or travel pedals are operated when the engine speed is decreased by the auto-deceleration function, the engine speed will suddenly increase. Operate the levers carefully.

Use the R.H. and L.H. work equipment control levers to operate the work equipment. When the levers are released, they return to NEUTRAL position and the work equipment is held in that position.

- Arm control
  - Move the L.H. work equipment control lever back and forth.
  - You can operate the arm.

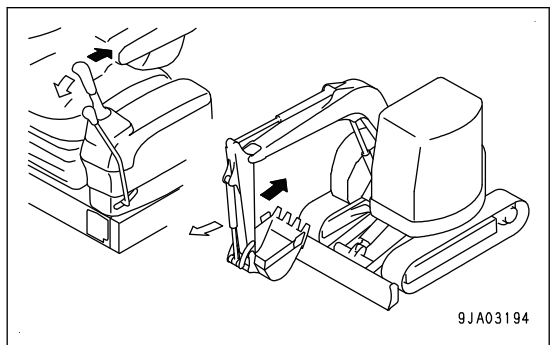

- Swing control
  - Move the L.H. work equipment control lever to the right and left.
  - The upper structure swings.

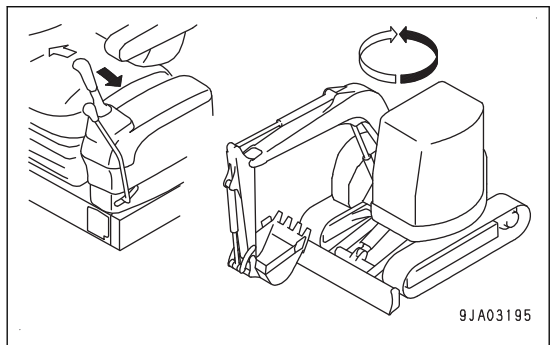

- Boom control

Move the R.H. work equipment control lever back and forth.

You can operate the boom.

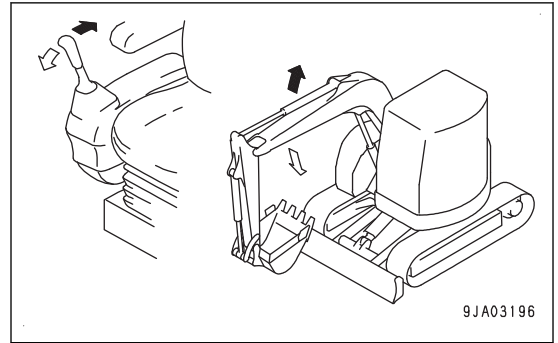

9JA03196

- Bucket control

Move the R.H. work equipment control lever to the right and left.

You can operate the bucket.

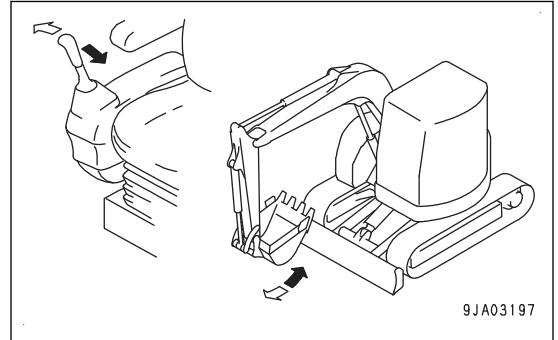

9JA03197

- Boom swing control

Depress either right or left of the boom swing control pedal.

You can swing the boom.

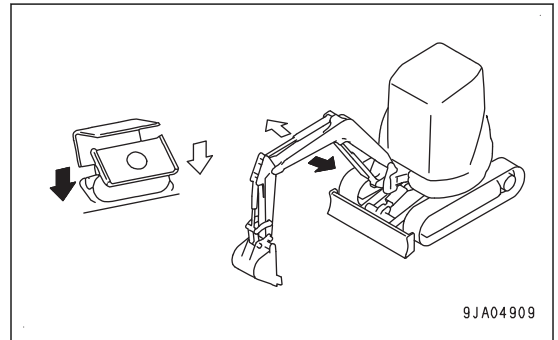

9JA04909

- Blade control

Move the blade control lever back and forth.

You can operate the blade.

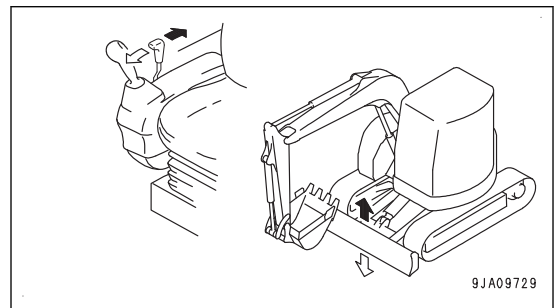

9JA09729

If the work equipment control levers are returned to NEUTRAL position when the machine is stopped, even if the fuel control dial is set to High idle (MAX) position, the auto-deceleration mechanism works to reduce the engine speed to a low-range speed.

#### REMARK

This machine is equipped with an accumulator in the control circuit. Even if the engine is stopped, if the starting switch key is turned to ON position within 15 seconds after stopping the engine, and the lock lever is set to FREE position, it is possible to use the lever operation to lower the work equipment to the ground.

This procedure can also be used for releasing the remaining pressure in the hydraulic cylinder circuits or for lowering the boom after loading the machine onto a trailer.

## HANDLE WORKING MODE

### METHOD FOR SELECTING WORKING MODE

Use working mode selector switch (1) to select the working mode that matches the operating conditions or purpose. This will make it possible to perform operations efficiently.

Use the following procedure to select the most efficient working mode.

When the starting switch is turned ON, the working mode is set to the mode that was in operation when the starting switch was last turned OFF.

Use the working mode selector switch to set the mode to the most efficient mode to match the type of work.

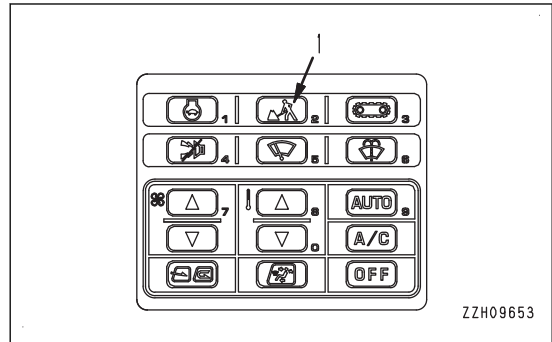

ZZH09653

Working mode	Applicable operations
P mode	Normal digging or loading operations (production conscious operation)
E mode	Normal digging or loading operations (fuel consumption conscious operation)
L mode	Aligning operations (fine control operation)
B mode	Breaker operations
ATT/P mode	Operations of double-acting attachment on crusher (production conscious operation)
ATT/E mode	Operations of double-acting attachment on crusher (fuel consumption conscious operation)

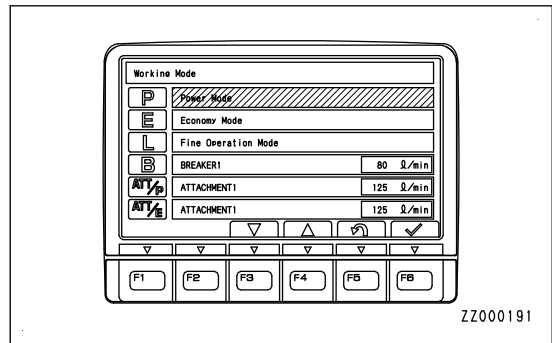

ZZ000191

### NOTICE

**If breaker operations are performed in a mode other than the breaker mode, there is danger of breakage of the hydraulic equipment. Do not perform breaker operations in any mode except the breaker mode.**

- Press working mode selector switch (1).  
The screen changes to "working mode" selection screen.

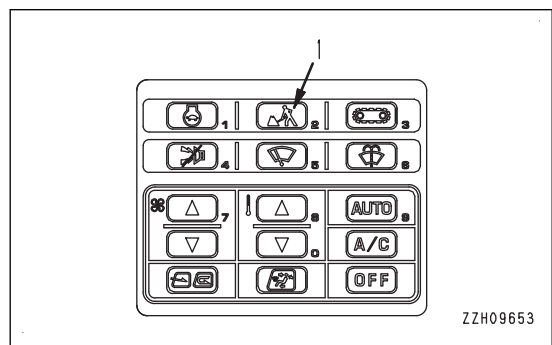

ZZH09653

- Press the working mode selector switch or, function switch F3 or F4 to select the appropriate mode.

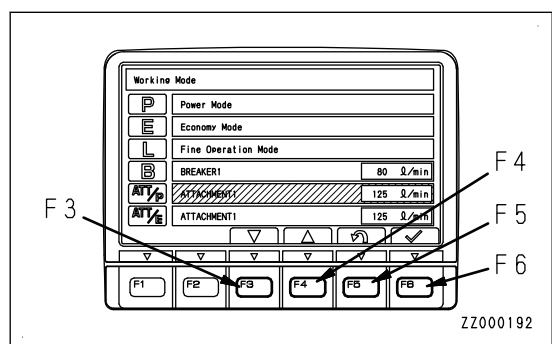

ZZ000192

3. Select a desired working mode and press function switch F6.

The change is entered and the screen returns to the standard screen.

If function switch F5 is pressed, the screen returns to the standard screen without changing the mode.

- If a working mode is selected, and nothing is done for 5 seconds, the selected working mode is automatically accepted and the screen returns to the standard screen.
- If a working mode is selected and working mode switch (1) is kept pressed, the selected mode is accepted and the screen returns to the standard screen.

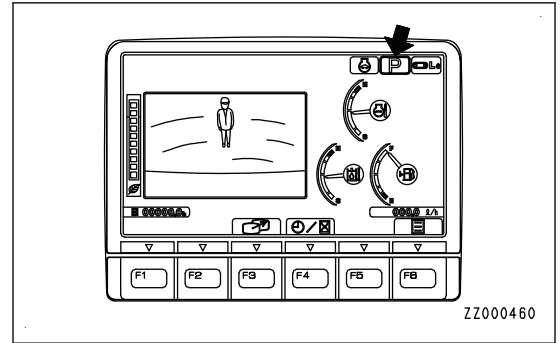

**PROHIBITED OPERATIONS**

**⚠ WARNING**

- Do not operate the work equipment control lever when the machine is traveling.
- If any lever is operated when the auto-deceleration is being actuated, the engine speed will suddenly increase, so be careful when operating.

**PROHIBITION OF OPERATIONS USING SWING FORCE**

Do not use the swing force to compact soil or break objects. This is not only dangerous, but also drastically reduces the life of the machine.

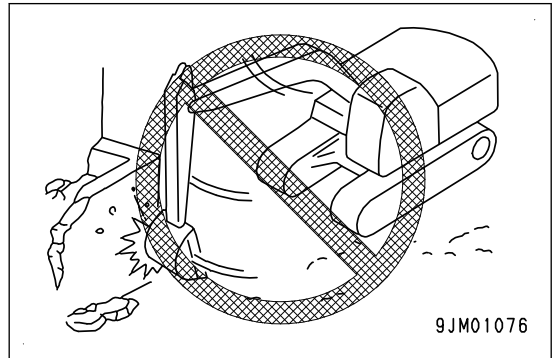

**PROHIBITION OF OPERATIONS USING TRAVEL FORCE**

Do not use the travel force to perform excavation by digging the bucket into the ground. This damages the machine or work equipment.

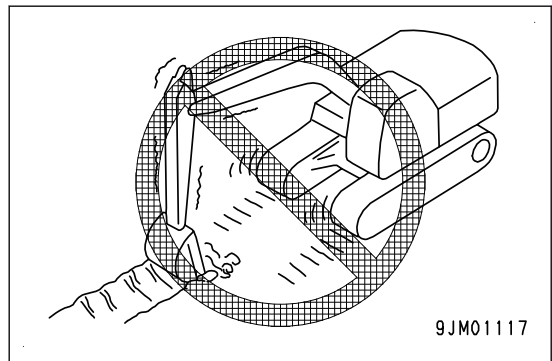

**PROHIBITION OF OPERATIONS USING HYDRAULIC CYLINDERS TO STROKE END**

If the work equipment is used with the cylinder rod operated to its stroke end, and given impact by some external force, the hydraulic cylinders may be damaged, causing personal injury. Do not perform operations with the hydraulic cylinder fully retracted or fully extended.

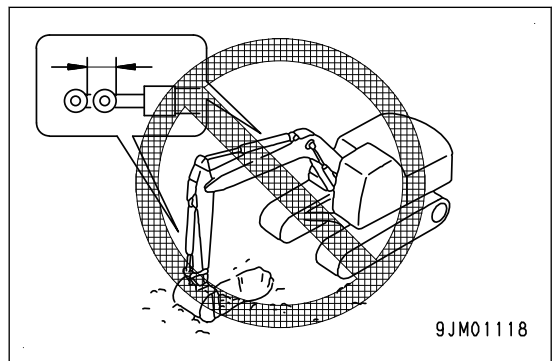

### PROHIBITION OF OPERATIONS USING BUCKET DROPPING FORCE

Do not use the dropping force of the machine for digging, nor use the dropping force of the bucket as a mattock, breaker, or pile driver. This will drastically reduce the life of the machine.

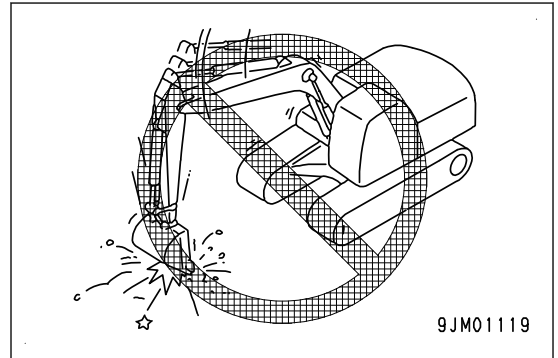

### PROHIBITION OF OPERATIONS USING BUCKET AS LEVER

Do not put the bucket back to a rock and use it as a lever to dig. This can apply an excessive force to the chassis and bucket, and the machine may break.

In this case, dig by using only the force of the arm or bucket. If an excessive force is applied, the safety valve of the hydraulic system controls it into a proper range to prevent breakage of the machine.

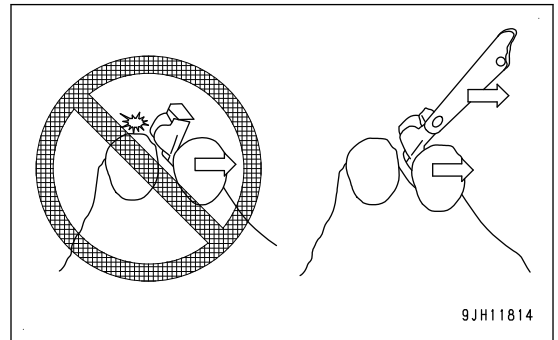

### PROHIBITION OF OPERATIONS USING MACHINE DROPPING FORCE

Do not use the dropping force of the machine for digging.

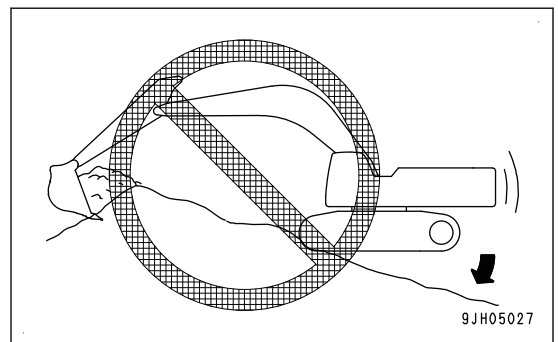
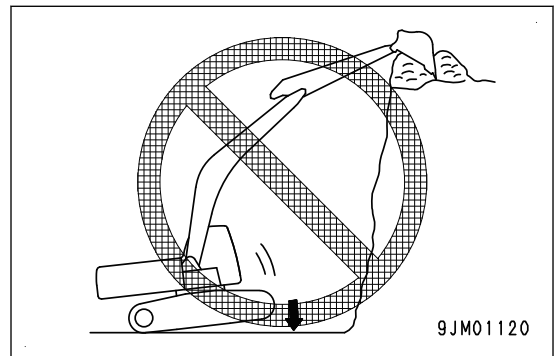

### PROHIBITION OF DIGGING OPERATION AT AN ANGLE WITHOUT ENGAGING TEETH

If the machine swings and digs simultaneously while the bucket blade does not bite into hard rocks at a position higher than the machine, the teeth slide down on the rock surfaces. As a result, large vibration occurs in the machine and can crack the work equipment or frame.

If the bucket blade slides and collides with a rock, an excessive impact load occurs in the work equipment and frame and can shorten the service life of the machine.

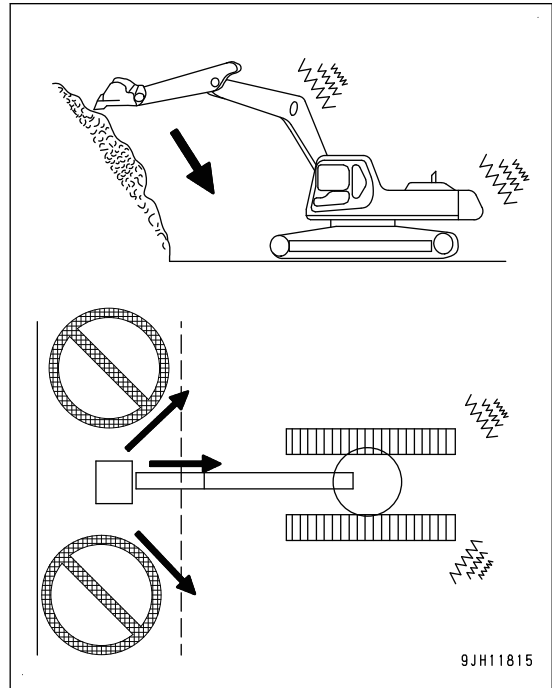

### PROHIBITION OF DIGGING OPERATION ON HARD ROCKY GROUND

Do not attempt to directly excavate hard rocky ground with the work equipment. It is better to excavate it after breaking up by some other means. This will not only save the machine from damage but will make for better economy.

### PROHIBITION OF OPERATIONS WHEN MACHINE IS NOT STABLE

If the machine is operated while its undercarriage is unstable, torsional loads occur in the frames and can shorten the service life of the machine.

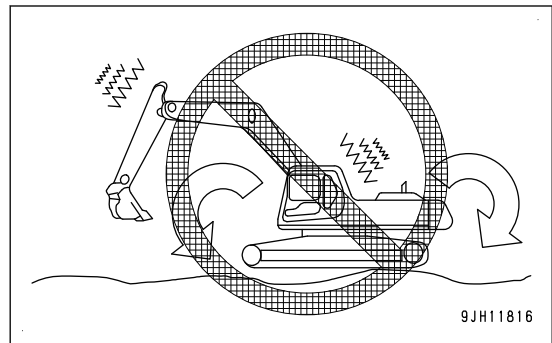

In this case, prepare an embankment, etc. in front of the track to stabilize the machine.

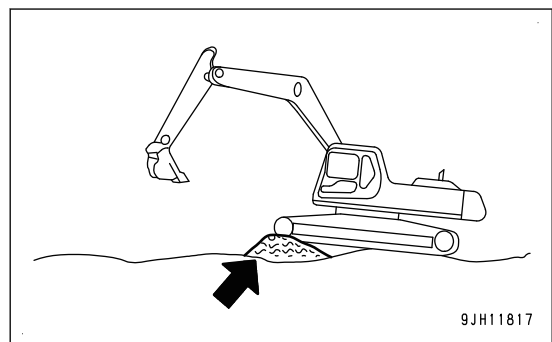

## PROHIBITION OF SWINGING OR TRAVELING WHEN ROCK IS ON TOP OF TRACK ASSEMBLY

If the machine travels or swings with crushed stones, soil, or sand on the track, they hit and damage the undercover and frame. In the worst case, the hydraulic components are damaged and a serious accident can result.

During operation, keep checking the track top for crushed stones, soil, and sand.

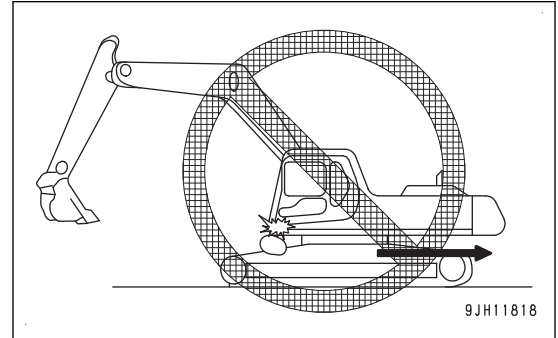

## DO NOT PERFORM LIFTING OPERATIONS

Although lifting operation with this machine is prohibited, it is permitted only when the special lifting hook is installed.

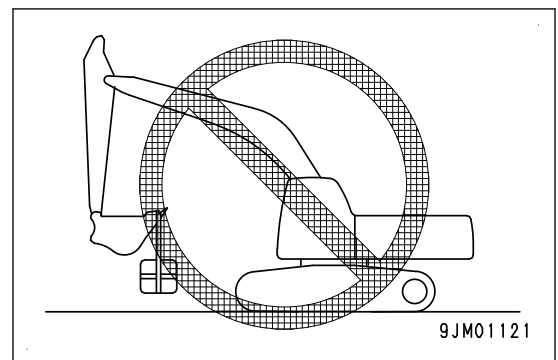

## PROHIBITION OF SUDDEN LEVER OR PEDAL SHIFT DURING HIGH SPEED TRAVEL

- (1) Do not operate the levers and pedals suddenly nor take any other action to move the machine quickly.
- (2) Do not operate the levers or pedals suddenly from FORWARD (A) to REVERSE (B) (or from REVERSE (B) to FORWARD (A)).
- (3) Do not operate the levers or pedals suddenly (do not release them suddenly) to stop the machine when driving it at high speed.

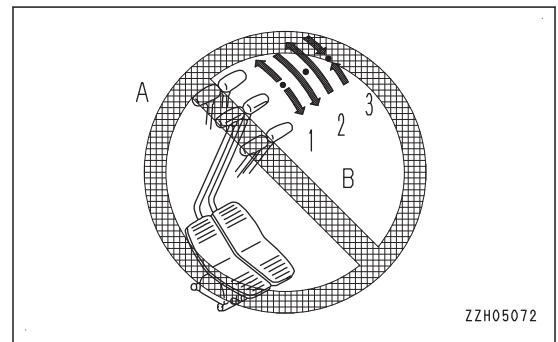



**PROHIBITION OF HIGH-SPEED TRAVEL OPERATIONS ON ROUGH GROUND**

If the machine travels on rough ground (rock-bed, etc.) at high speed, large push-up loads are applied to the chassis, thus the service life of the chassis is shortened.

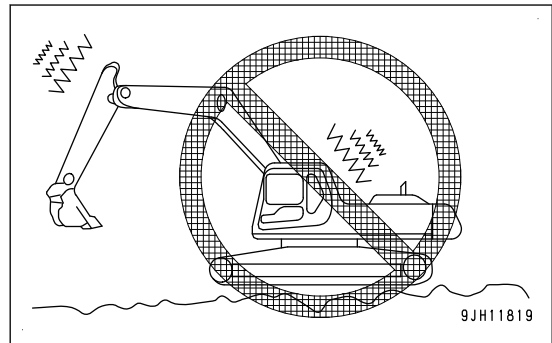

When driving on rough ground (rock-bed, etc.), direct the idler (1) having the cushion mechanism in the travel direction and drive the machine at low speed.

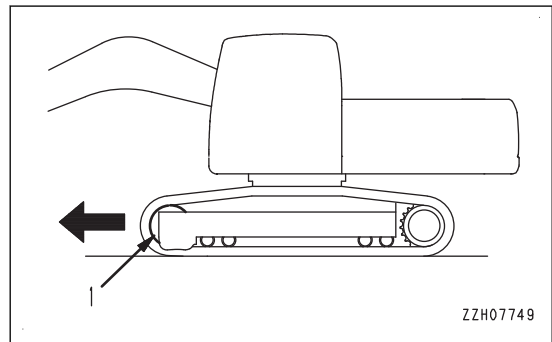

**GROUND WHOLE THE BOTTOM SIDE OF BLADE TO SUPPORT MACHINE**

When using the blade as an outrigger, never support the machine with only one end of the blade.

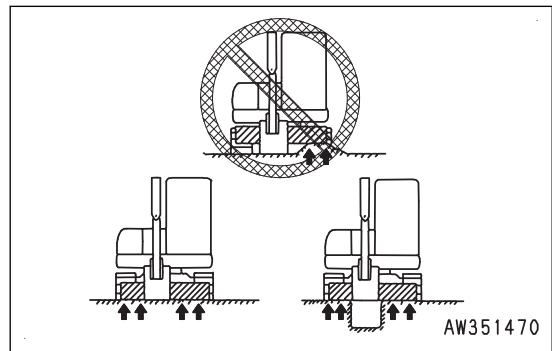

**DO NOT TRAVEL LONG -TIME CONTINUOUSLY**

If the machine travels continuously at high speed for 1.5 hours or more, the lubricating oil inside the track rollers and final drive will rise to a high temperature. There is a danger that this will cause damage to the oil seal or leakage of oil.

When driving the machine continuously for a long time, stop it for 30 minutes every one and a half hours to cool the lubricating oil inside the track rollers and final drives.

If the machine travels continuously for a long time with the tracks loosened, the undercarriage parts may be broken early.

When driving the machine for a long time, check the track tension every 1.5 hours and adjust any looseness.

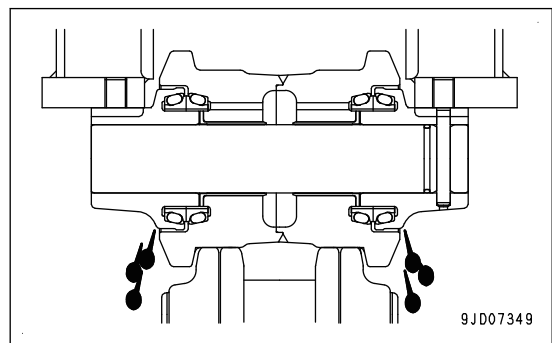

For the adjustment, see MAINTENANCE, "METHOD FOR CHECKING AND ADJUSTING TRACK TENSION".

## PRECAUTIONS FOR OPERATION

### PRECAUTIONS FOR TRAVELING

Traveling over boulders, tree stumps, or other obstacles will cause a big shock to the chassis (and in particular to the undercarriage), and this will cause damage to the machine. For this reason, always remove any obstacles or drive the machine around them, or take other steps to avoid traveling over such obstacles as far as possible.

If there is no way to avoid traveling over an obstacle, reduce the travel speed, keep the work equipment close to the ground, and try to drive the machine so that the center of the track passes over the obstacle.

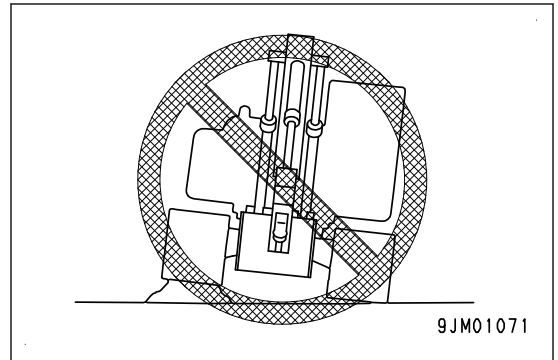

### PRECAUTIONS FOR HIGH SPEED TRAVEL

On uneven roadbeds such as rock beds or uneven roads with large rocks, drive the machine at “Lo” speed. When driving the machine at “Hi” speed, direct the idler forward.

- Press travel speed selector switch (1) to switch the travel speed. The travel speed (“Lo”, “Hi”) is displayed on travel speed display (2).

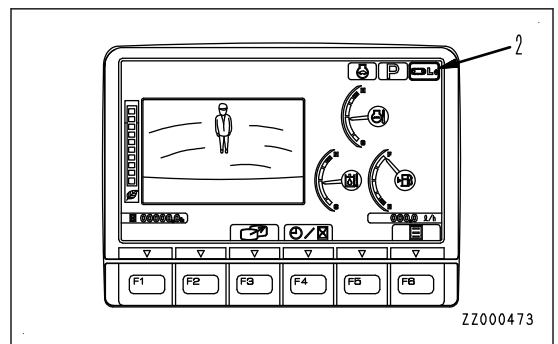
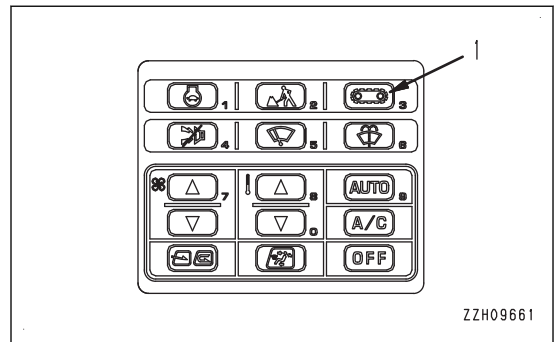

### PRECAUTIONS FOR FOLDING WORK EQUIPMENT

When folding in the work equipment to the travel or transportation posture, be careful not to let the bucket hit the blade.

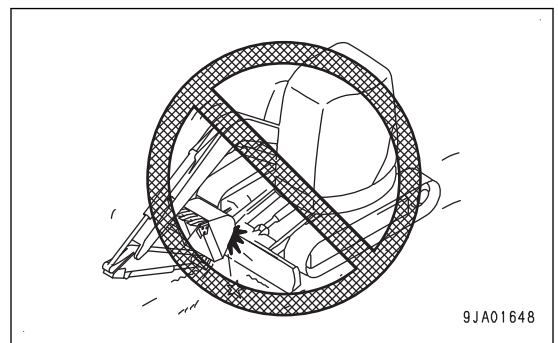

### PRECAUTIONS FOR HITTING BLADE AGAINST OBJECTS DURING OPERATING BLADE

Be careful not to hit the blade against rocks or boulders. This will cause premature damage to the blade or cylinders.

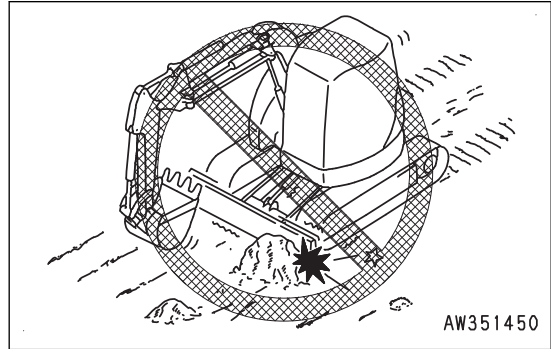

### PRECAUTIONS FOR BLADE POSITION DURING BACKHOE OPERATION

When digging in front of the blade, take care that the boom cylinder does not touch the blade. Dig with the blade at the rear usually, and dig in front of the blade only when required.

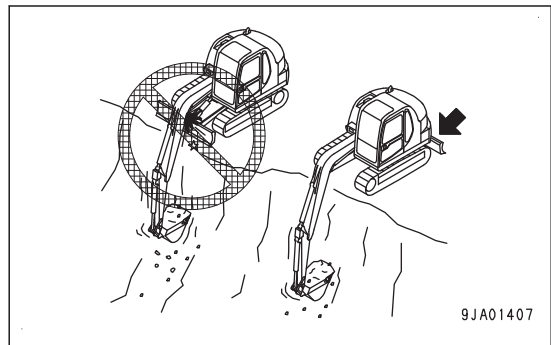

### PERMISSIBLE DEPTH OF WATER, SOIL AND DIRT

#### NOTICE

When traveling the machine out of water, if the angle of the machine exceeds 15°, the rear of the upper structure will go under water, and water will be thrown up by the radiator fan, This may cause the fan to break. Be extremely careful when driving the machine out of water.

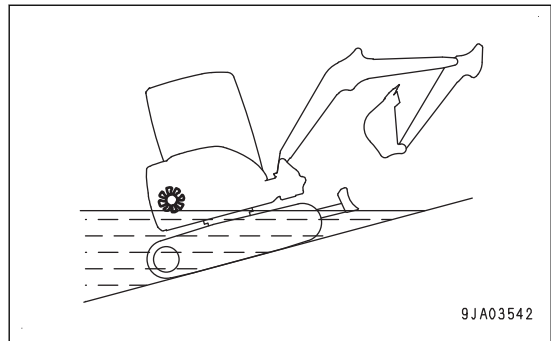

Do not drive the machine in water or soil and dirt deeper than the center of carrier roller (1).

After the job, be sure to supply grease to the parts which have been under water for a long time until the used grease is projected. (Around the bucket pin, in particular)

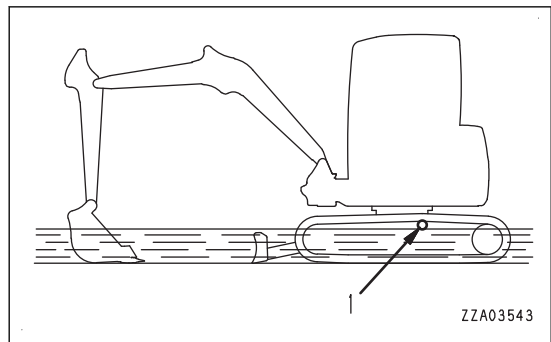

## PRECAUTIONS FOR WORKING ON SLOPE

### ⚠ WARNING

- Swinging operations or operating the work equipment on slopes machine may lose its balance and turn over. Avoid such operations as much as possible. It is particularly dangerous to swing downhill when the bucket is loaded. It is unavoidable to perform such operations, pile soil to make a platform (A) on the slope so that the machine can be horizontal.
- Do not work or travel on a slope covered with the steel plates. Even with slight slopes there is a hazard that the machine may slip.
- Do not travel up or down on steep slopes. There is a danger that the machine may turn over.
- When traveling, raise the bucket approximately 20 to 30 cm (8 to 12 in) above the ground. Do not travel downhill in reverse.
- Never turn on slopes or travel across slopes. Always go down to a flat place to perform these operations. It may be a longer way, but it will ensure safety.
- Always operate or travel in such a way that it is possible to stop safely at any time if the machine slips or becomes unstable.
- When traveling uphill, if the shoes slip or it is impossible to travel uphill using only the force of the tracks, do not use the pulling force of the arm to help the machine travel uphill. There is danger that the machine may tip over. Accordingly, don't travel uphill with this method.

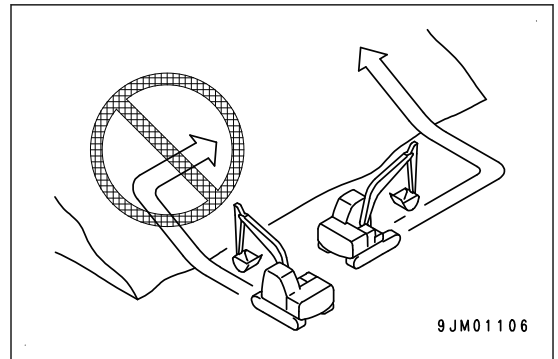
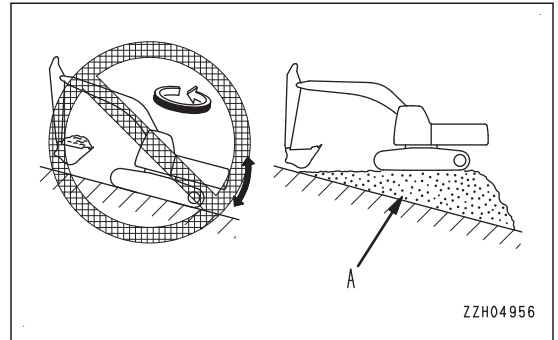

- When traveling down steep hills, use the travel lever and fuel control dial to keep the travel speed low.

When traveling down a steep hill of more than 15 deg., set the machine to the posture shown in the figure with sprocket (1) downward and lower the engine speed.

a: 20 to 30 cm (8 to 12 in)

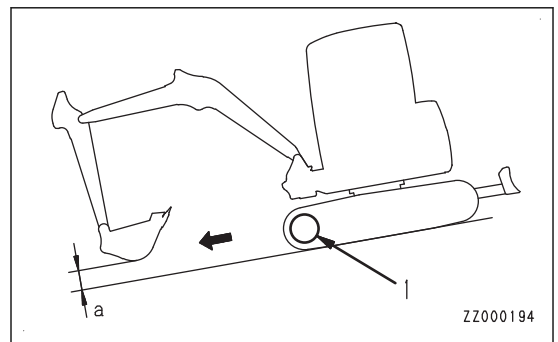

### REMARK

Travel down with sprocket (1) downward. If the machine travels down with sprocket (1) upward, the tracks may be loosened and may jump teeth.

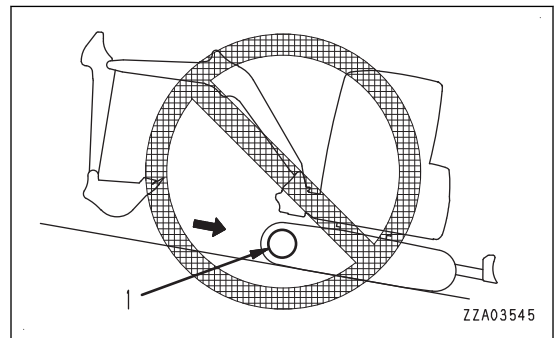

2. When traveling up a steep hill of more than 15 deg., set the work equipment to the posture shown in the figure.  
a: 20 to 30 cm (8 to 12 in)

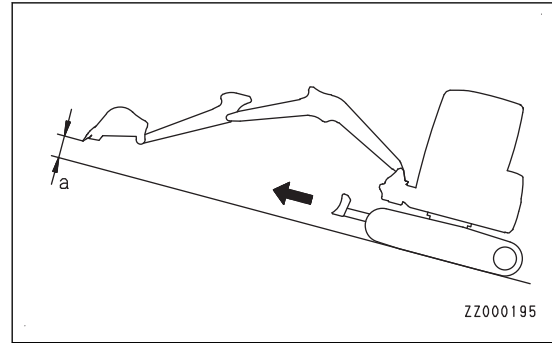

### **BRAKING ON DOWNHILL SLOPE**

Put the travel lever in NEUTRAL position. This will cause the brake to be automatically applied.

### **IF ENGINE STOPS ON SLOPE**

If the engine stops when traveling uphill, move the travel levers to the neutral position, lower the bucket to the ground, stop the machine, then start the engine again.

### **WHEN OPERATING ON SLOPE**

- Never perform swing operation on a slope by using the left work equipment control lever if the engine stops. The upper structure will swing under its own weight.
- Do not open or close the slide door while traveling or operating the machine on a slope. The operating effort may suddenly change. Always keep the slide door locked.
- When opening or closing the slide door while the machine is stopped, take extreme care. The door opens or closes suddenly under its own weight, and it is dangerous.

## METHOD FOR ESCAPING FROM MUD

Always operate carefully to avoid getting stuck in mud. If the machine does get stuck in mud, do as follows to get the machine out.

### When track on either side gets stuck

#### NOTICE

**When using the boom or arm to raise the machine, always have the bottom of the bucket in contact with the ground. (Do not raise with the teeth in contact with the ground)**

**The angle between the boom and arm should be 90 to 110 deg.**

**The same applies when using the bucket installed in the reverse direction.**

When the track on either side gets stuck, pull out the machine according to the following procedure.

1. Move the bucket to the side of the stuck track and press the ground with it.  
The track is raised.
2. Place logs, wooden blocks, etc. under the track.
3. Raise the bucket and escape.

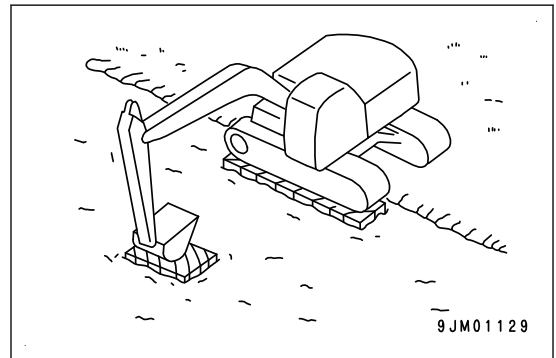

### When tracks on both sides get stuck

When the tracks on both sides get stuck, pull out the machine according to the following procedure.

1. Place logs, wooden blocks, etc. under the tracks according to the above procedure.
2. Push the bucket into the front ground.
3. Move the arm IN as in digging work and set the travel lever to FORWARD to pull out the machine.

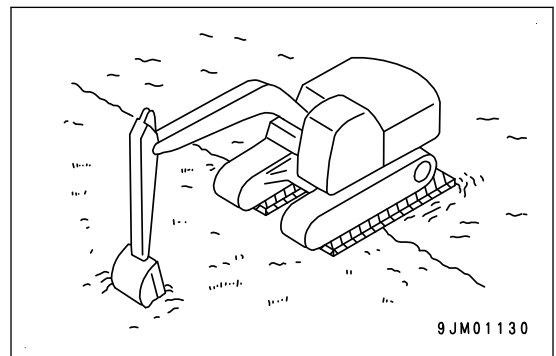

## RECOMMENDED APPLICATIONS

In addition to the following, it is possible to further increase the range of applications by using various attachments.

### DIGGING WORK

#### BACKHOE WORK

A backhoe is suitable for excavating areas that are lower than the machine.

When the condition of the machine is as shown in the figure (angle between "bucket cylinder and link" and "arm cylinder and arm" is 90 deg.), the maximum excavation force is obtained from the pushing force of each cylinder.

When excavating, you can optimize your working efficiency by using this angle effectively.

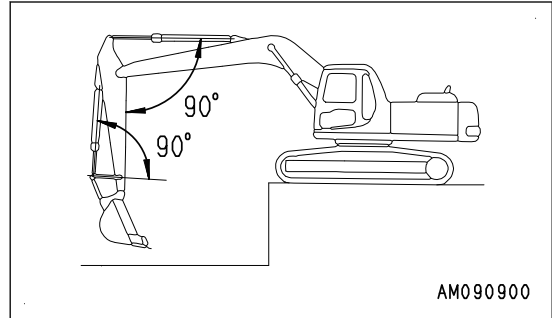

The range for excavating with the arm is from a 45 deg. angle away from the machine to a 30 deg. angle towards the machine.

There may be some differences depending on the excavation depth, but try to stay within the above range rather than operating the cylinder to the end of its stroke.

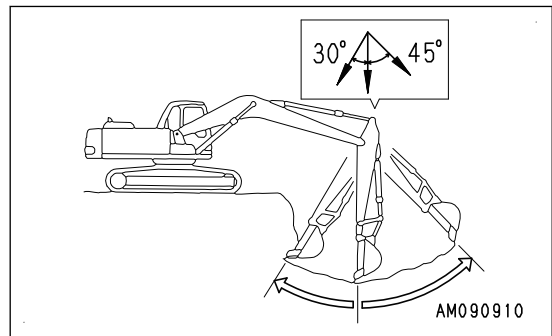

### SHOVEL WORK

A shovel is suitable for excavating at a position higher than the machine.

Shovel work is performed by attaching the bucket in the reverse direction.

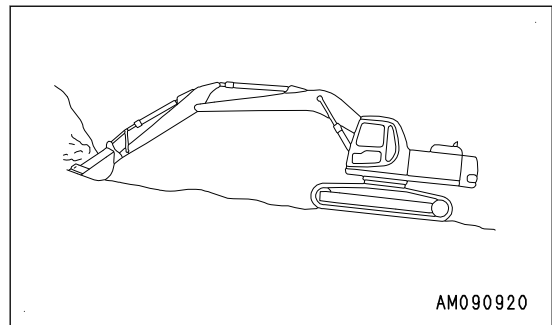

### DITCHING WORK

Ditching work can be performed efficiently by attaching a bucket which matches the digging operation and then setting the tracks parallel to the line of the ditch to be excavated.

To excavate a wide ditch, first dig both sides and then finally remove the center portion.

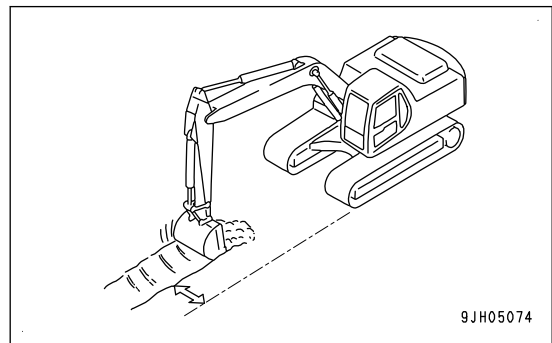

## SIDE DITCHING WORK

The operator can perform ditching work in a narrow space by combining swing and boom swing operations.

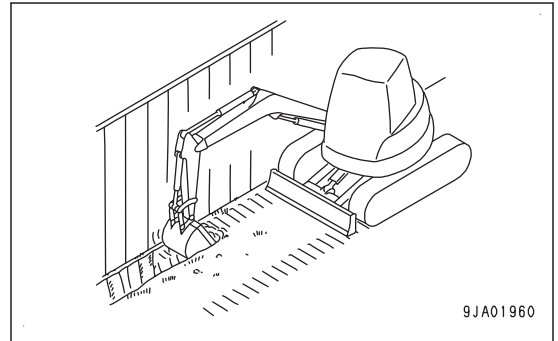

## LOADING WORK

In places where the swing angle is small, work efficiency can be enhanced by locating the dump truck in a place easily visible to the operator.

Loading is easier and capacity becomes greater if you stop the machine at the rear of the dump truck than if loading is done from the side.

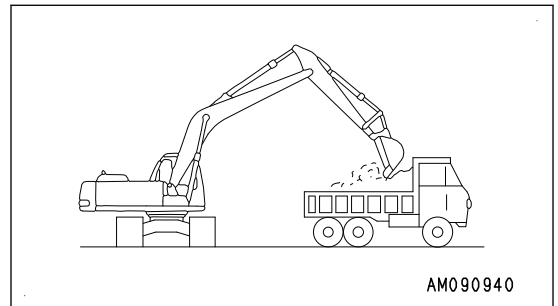

## LEVELING WORK

Use the blade for back filling and leveling work after digging ground.

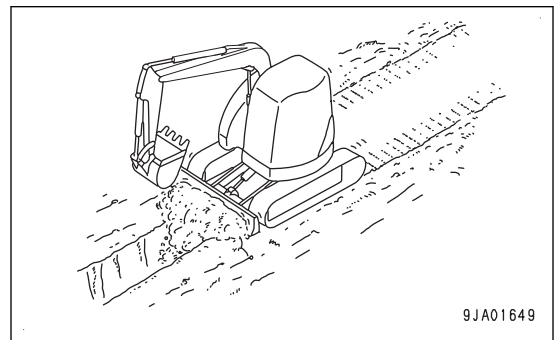



## METHOD FOR REPLACING AND INVERTING BUCKET

### WARNING

- When pins are knocked in with a hammer, pieces of metal may fly and cause serious injury. When performing this operation, always wear goggles, hard hat, gloves, and other personal protective items.
- Place the removed bucket in a stable condition.
- The pin is hit with a strong force to remove, so the pin may fly out and injure people in the surrounding area. Make sure that there is no one in the surrounding area before starting the work.
- When removing the pins, do not stand behind the bucket. In addition, be extremely careful not to put your foot on the side of the bucket.
- When removing or inserting pins, be extremely careful not to get your fingers caught.
- Never insert your fingers into the pin holes when aligning the holes.

Stop the machine on a firm and flat surface and do the work. When performing joint work, appoint a leader and follow that person's instructions and signals.

### Replace

1. Place the bucket in contact with a flat surface of the ground.

#### REMARK

When removing the pins, place the bucket so that it is in light contact with the ground. If the bucket is lowered strongly to the ground, the resistance will be increased and it will be difficult to remove the pins.

#### NOTICE

After removing the pins, make sure that mud or sand does not get on them. Dust seals are fitted at both ends of the bushings, be careful not to damage them.

2. Remove the double nut of stopper bolt at arm pin (A) and link pin (B), then pull out the bolts.
3. Pull out arm pin (A) and link pin (B), then remove the bucket.

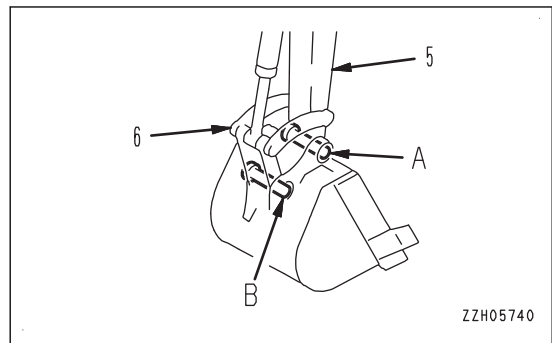

4. Align arm (5) with hole (1) of the replacement bucket.
5. Align link (6) with hole (2) of the replacement bucket.
6. Apply grease to pins (A) and (B) and insert them into holes (1) and (2) of the bucket.

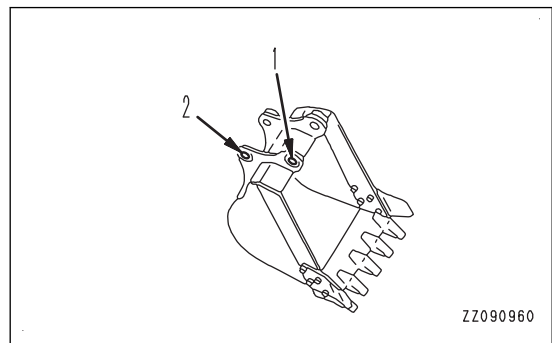

**REMARK**

- Perform installation in the reverse order to removal.
- Fit O-ring (3) to arm (5) as shown in the figure since it is damaged easily when bucket (4) is installed. After inserting the pin, fit it in the regular groove.

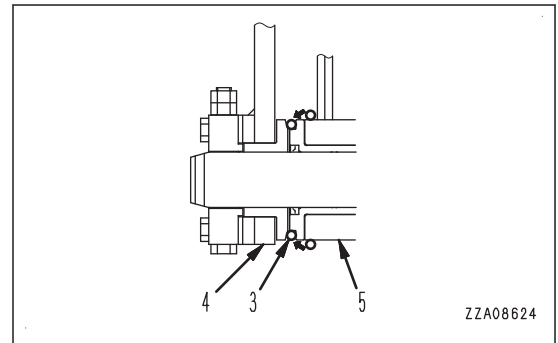

7. Install the lock bolt and nut of each pin.
8. Apply grease to each pin.

**REMARK**

- Lubricate with grease thoroughly until the grease comes out from the end faces.
- When replacing the bucket, replace the dust seal with a new one if it is damaged. If a damaged seal is used without being replaced, sand and dirt may enter the pin portion and cause abnormal wear of the pin.

**Invert**

**WARNING**

When reversing a bucket, there is the danger that the bucket tooth tip overruns the normal trajectory and interferes with the cab, thus causing a serious trouble.

Pay good attention to the work when reversing a bucket so that the bucket and the cab may not interfere with each other.

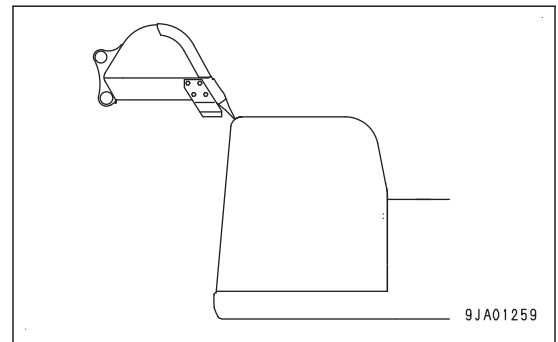

1. Place the bucket in contact with a flat surface of the ground.

**REMARK**

When removing the pins, place the bucket so that it is in light contact with the ground.

If the bucket is lowered strongly to the ground, the resistance will be increased and it will be difficult to remove the pins.

**NOTICE**

After removing the pins, make sure that mud or sand does not get on them. Dust seals are fitted at both ends of the bushings, be careful not to damage them.

2. Remove the double nut of stopper bolt at arm pin (A) and link pin (B), then pull out the bolts.
3. Pull out arm pin (A) and link pin (B), then remove the bucket.

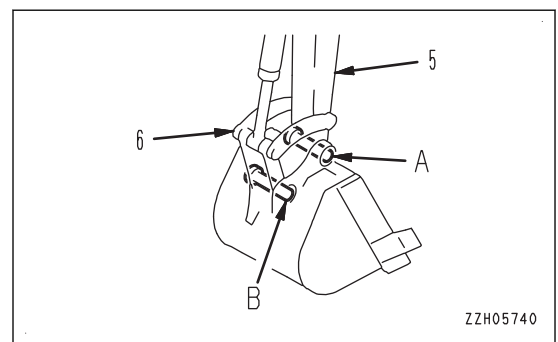

4. Invert the removed bucket.

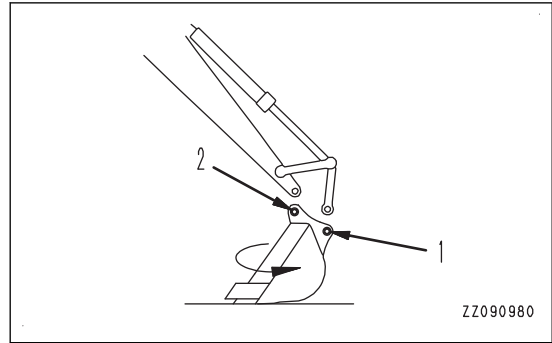

- 5. Align arm (5) with mounting hole (1) of link (6).
- 6. Align link (6) with mounting hole (2) of arm (5).
- 7. Insert grease-coated pins (A) and (B) into hole (1) and hole (2) respectively.

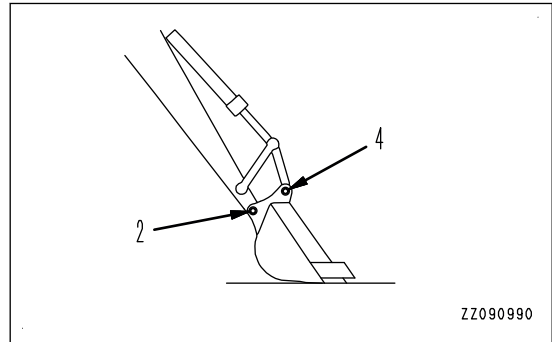

**REMARK**

Fit O-ring (3) to mounting portion (1) of arm (5) and bucket (4).

Fit O-ring (3) to arm (5) as shown in the figure since it is damaged easily when bucket (4) is installed. After inserting the pin, fit it in the regular groove.

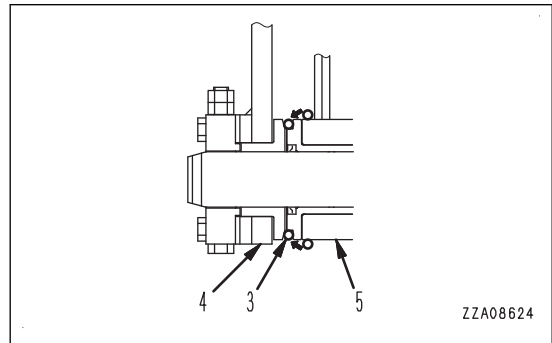

- 8. Install the lock bolt and nut of each pin.
- 9. Apply grease to each pin.

**REMARK**

- Lubricate with grease thoroughly until the grease comes out from the end faces.
- When replacing the bucket, replace the dust seal with a new one if it is damaged. If a damaged seal is used without being replaced, sand and dirt may enter the pin portion and cause abnormal wear of the pin.

## METHOD FOR PARKING MACHINE

**⚠ WARNING**

- Place the machine on a firm and level place.  
Do not park the machine on a slope.  
If it is unavoidably necessary to park the machine on a slope, put blocks to the track shoes. As an additional safety measure, thrust the bucket into the ground.
  - If the control lever is touched by accident, the machine may move suddenly, and this may lead to a serious personal injury or death. Always set the lock lever securely to LOCK position before leaving the operator's seat.
  - Lower the blade to the ground on the downhill side.
1. Set right and left travel levers (1) in NEUTRAL position (N).  
The machine stops.

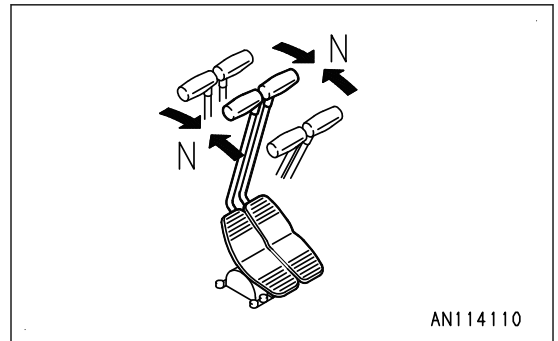
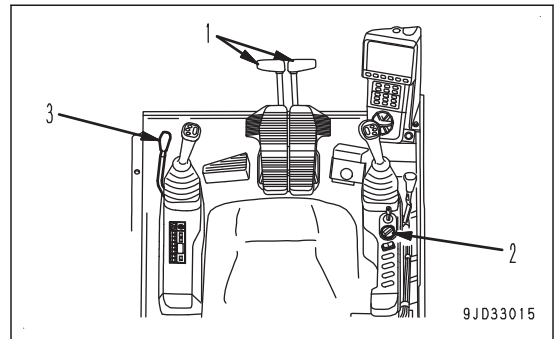
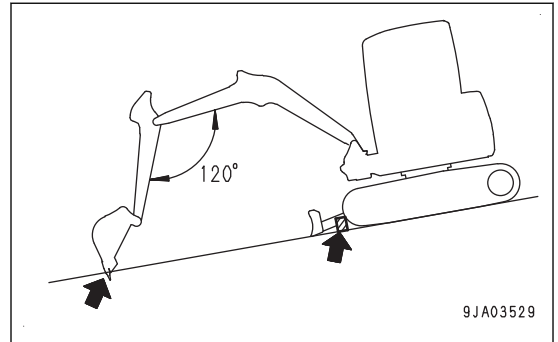

2. Turn fuel control dial (2) to Low idle (MIN) position and lower the engine speed.

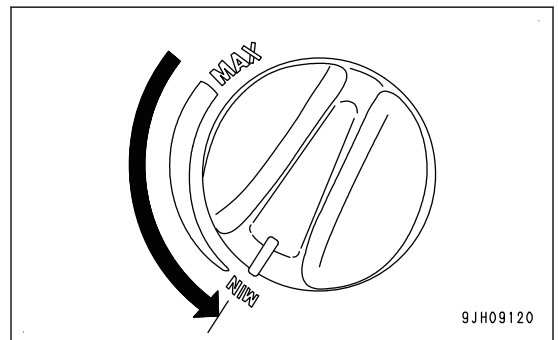

3. Lower the bucket horizontally until the bottom touches the ground.
4. Lower the blade to the ground.

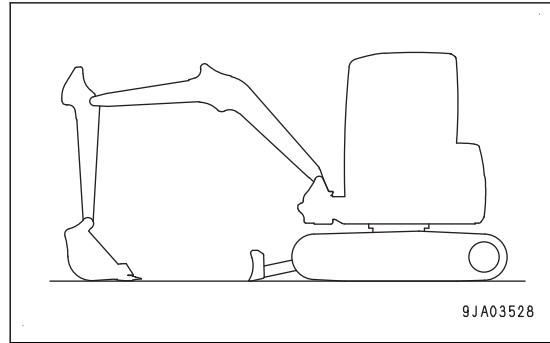

5. Set lock lever (3) in LOCK position (L).

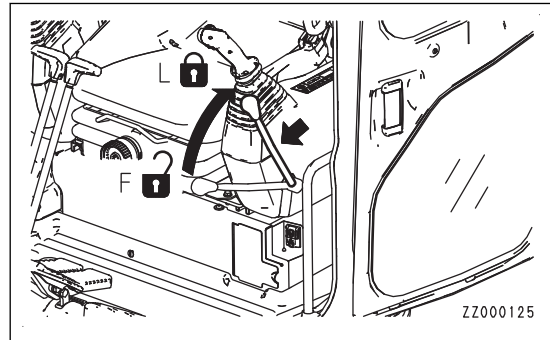

6. Check the engine coolant temperature and engine oil pressure with the machine monitor.
  - If the engine coolant temperature gauge is in the red range, cool down the coolant until the gauge enters the green range, and stop the engine. Then, inspect and take necessary remedy according to "TROUBLES AND ACTIONS".
  - If the engine oil pressure caution lamp is lit, stop the engine immediately. Then, inspect and take necessary remedy according to "TROUBLES AND ACTIONS".

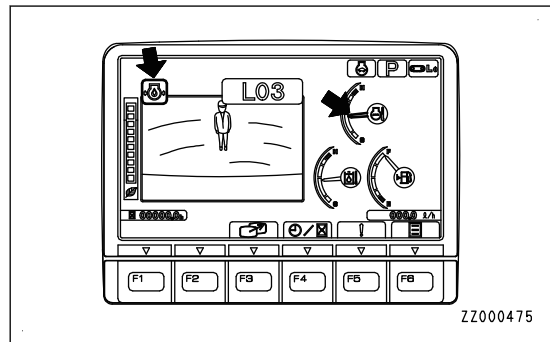

7. Stop the engine.

## METHOD FOR CHECKING AFTER FINISHING WORK

Perform it after stopping the engine.

1. Walk around the machine and check the work equipment, machine exterior, and undercarriage, also check for any leakage of oil or coolant. If any problems are found, repair them.
2. Fill the fuel tank.
3. Check the engine compartment for paper and debris. Clean out any paper and debris to avoid a fire hazard.
4. Remove any mud affixed to the undercarriage.

## LOCK

### Lock position

Always lock the following places.

- (1) Operator's cab door
- (2) Toolbox and grease pump storage cover
- (3) Engine hood
- (4) Dirt cover
- (5) Battery inspection cover
- (6) Air conditioner fresh air filter storage cover

### REMARK

Use the starting switch key to lock and unlock all these places.

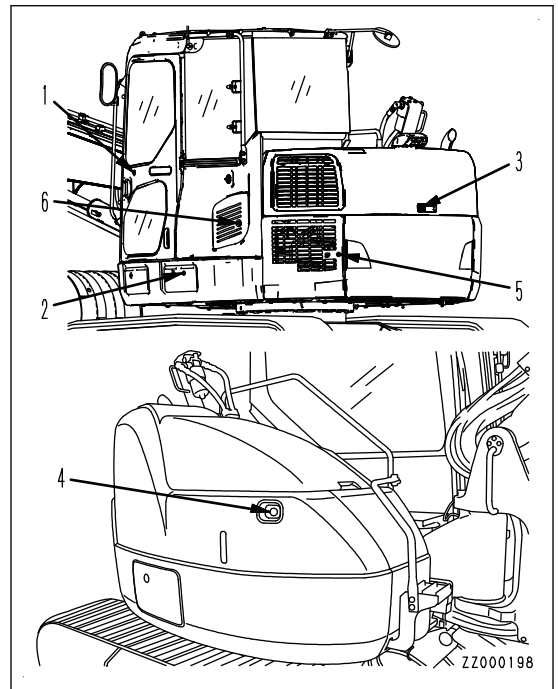

**METHOD FOR OPENING AND CLOSING COVER WITH LOCK****METHOD FOR OPENING COVER WITH LOCK**

1. Insert the key into the key slot.
2. Turn the key counterclockwise and open the cover by pulling the cover handle.

Position (A): OPEN

Position (B): LOCK

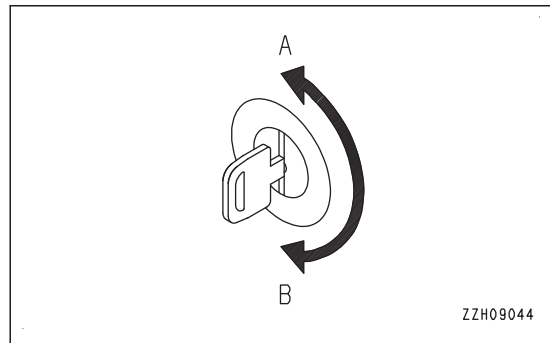
**METHOD FOR LOCKING COVER WITH LOCK**

1. Close the cover and insert the key into the key slot.
2. Turn the key clockwise and remove it.

## METHOD FOR OPENING AND CLOSING ENGINE HOOD

### ⚠ CAUTION

- When opening or closing the engine hood, place the machine on a level ground, lower the work equipment to the ground, stop the engine, then perform the operation.
- When inspecting or servicing the inside of the engine hood, be sure to fix the engine hood open by using the engine hood support lever.
- When opening the engine hood, do not release the handle until the hood support lever is set in the lock position securely.
- When closing the engine hood, hold the handle securely since the engine hood may moves down because of its weight.
- Immediately after the engine is stopped, the engine hood is still hot. Accordingly wait until it has cooled down before opening or closing the engine hood.
- Never stand on the engine hood. You may slip and fall.
- When driving the machine, always keep the engine hood closed unless you are inspecting.

### NOTICE

Always keep the hood locked unless you need to open it.

You can see if the cover is locked by checking the direction of the key slot of the cover knob.

### METHOD FOR OPENING ENGINE HOOD

1. Insert the key into the key slot.
2. Turn the key counterclockwise (A) and remove it.  
Position (A): OPEN  
Position (B): LOCK
3. While pushing engine hood opening knob (1), hold the hood grip and open hood (2).

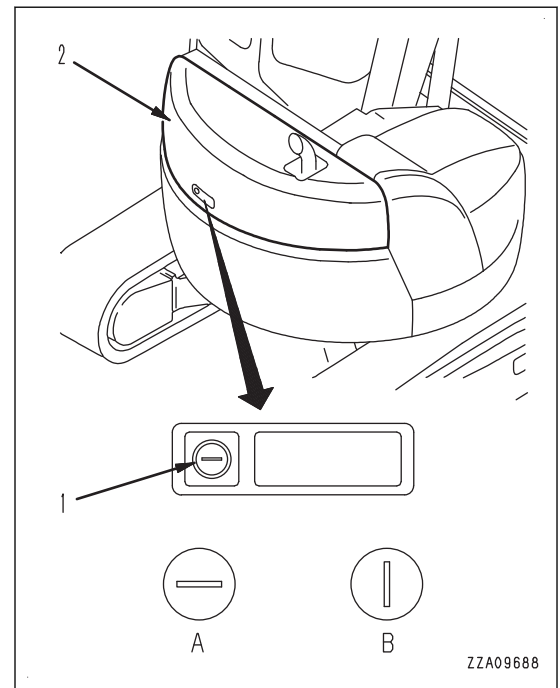

4. Set hood support lever (3) to the hood fixing position.  
There are 2 hood fixing positions prepared so that you can select a proper opening angle, depending on the part you are going to check. Select either fixing position according to the type of the work.

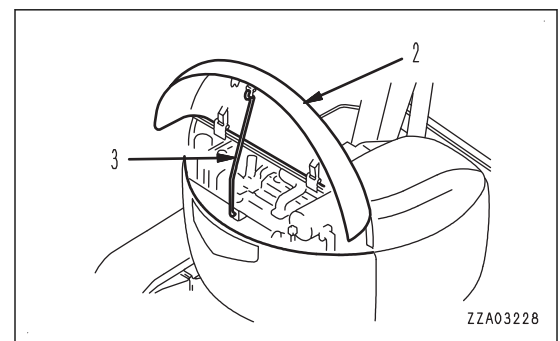



For checks before starting

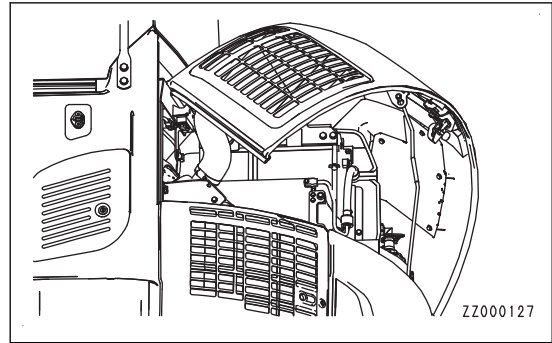

For maintenance other than checks before starting

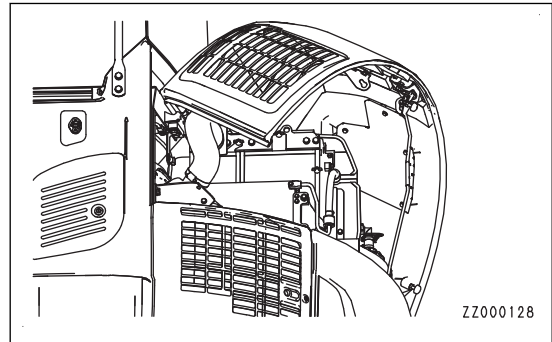

**METHOD FOR LOCKING ENGINE HOOD**

1. Hold the grip of hood (2) and remove hood support lever (3) from the hood fixing position.
2. Securely fix hood support lever (3) to the lever lock.
3. Lower and press the hood slowly to lock it securely.
4. Insert the key into the key slot.

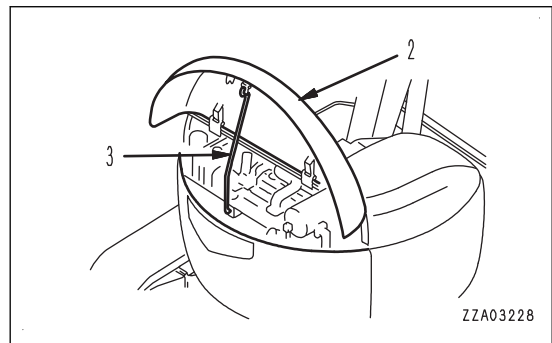

5. Turn the key clockwise (B) and remove it.  
 Position (A): OPEN  
 Position (B): CLOSE

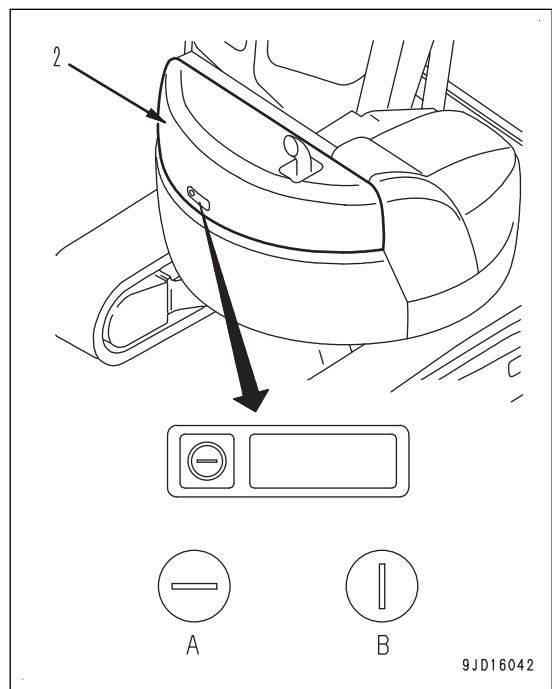

## METHOD FOR OPENING AND CLOSING DIRT COVER

### CAUTION

- Never stand on the cover. You may slip and fall.
- When inspecting or servicing the inside of the cover, be sure to fix the cover open by using the cover support lever.
- When driving the machine, always keep the cover closed unless you are inspecting.

### NOTICE

Always keep the cover locked unless you need to open it.  
You can see if the cover is locked by checking the direction of the key slot of the cover knob.

### METHOD FOR OPENING DIRT COVER

1. Insert the key into the key slot.
2. Turn the key counterclockwise (A) and remove it.  
Position (A): OPEN  
Position (B): LOCK
3. While pushing dirt cover release knob (1), hold the cover grip and open cover (2).

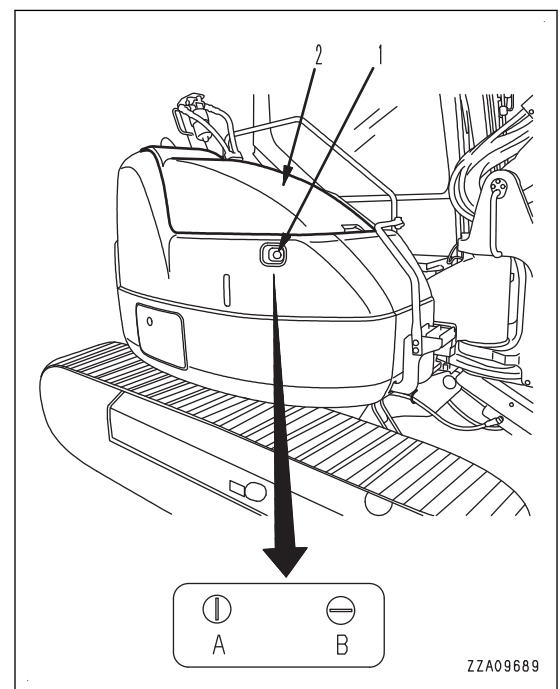

4. Set cover support lever (3) to the cover fixing position.

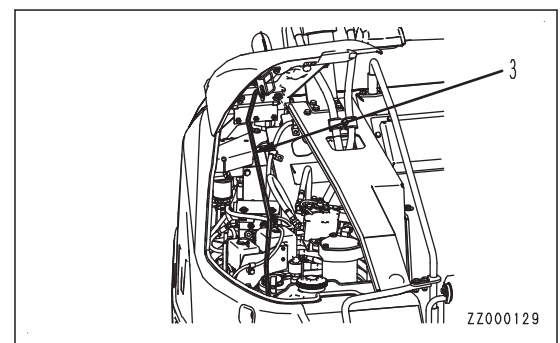

**METHOD FOR LOCKING DIRT COVER**

1. Hold the grip of hood (2) and remove hood support lever (3) from the hood fixing position.
2. Securely fix cover support lever (3) to the lever lock.
3. Lower and press the cover slowly and lock it securely.

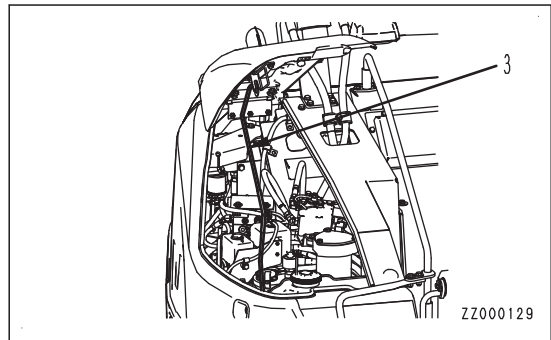

4. Insert the key into the key slot.
5. Turn the key clockwise (B) and remove it.

Position (A): OPEN

Position (B): CLOSE

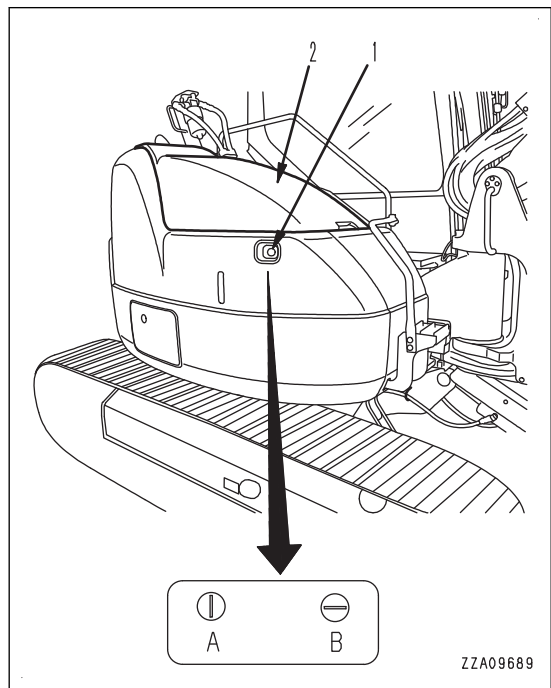

## METHOD FOR OPENING AND CLOSING BATTERY INSPECTION COVER

### CAUTION

- When inspecting or servicing the inside of the cover, be sure to fix the cover open by using the cover support lever.
- When operating the machine, always keep the cover closed unless you are inspecting.

### NOTICE

Always keep the cover locked unless you need to open it.

### METHOD FOR OPENING BATTERY INSPECTION COVER

1. Insert the key into key slot (1).
2. Turn the key counterclockwise and remove it.
3. Pull knob (2) and open cover (3).

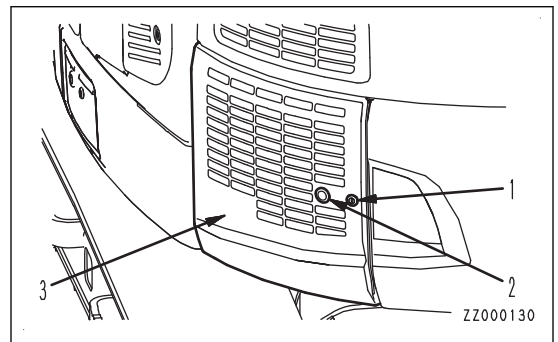

4. Remove cover support lever (4) from mounting hole (5) of cover (3).
5. Insert cover support lever (4) into hole (6) of the bottom cover.

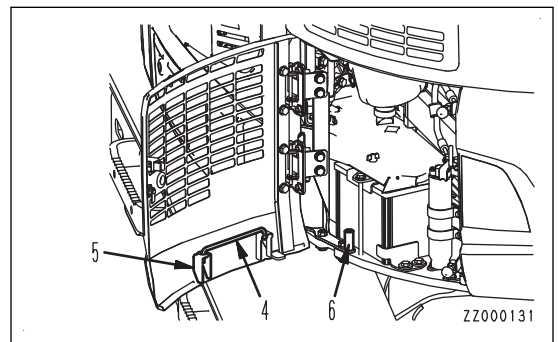

### METHOD FOR LOCKING BATTERY INSPECTION COVER

1. Remove cover support lever (4) from hole (6) of the bottom cover.
2. Insert cover support lever (4) into cover mounting hole (5).

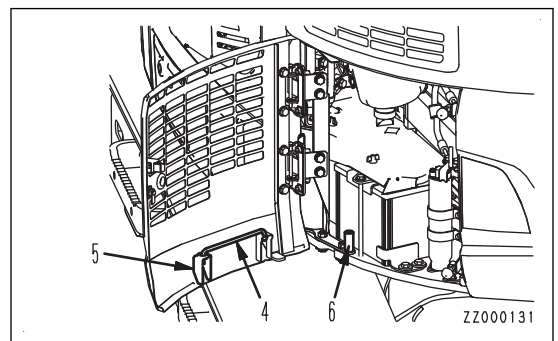

3. Close cover (3) slowly.
4. Insert the key into key slot (1).
5. Turn the key clockwise and remove it.

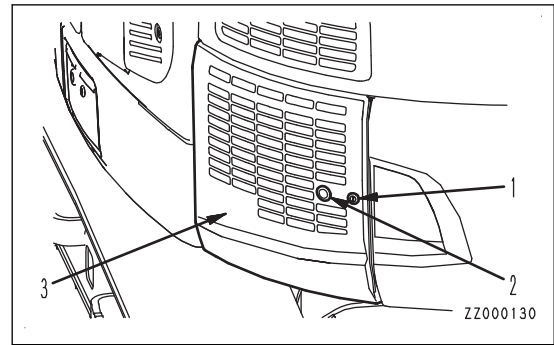

## METHOD FOR OPENING AND CLOSING CAB DOOR

### Open (Door is locked.)

1. Insert the key into the key slot.
2. Turn the key clockwise to unlock the key, then open the door handle.

Position (A): OPEN

Position (B): LOCK

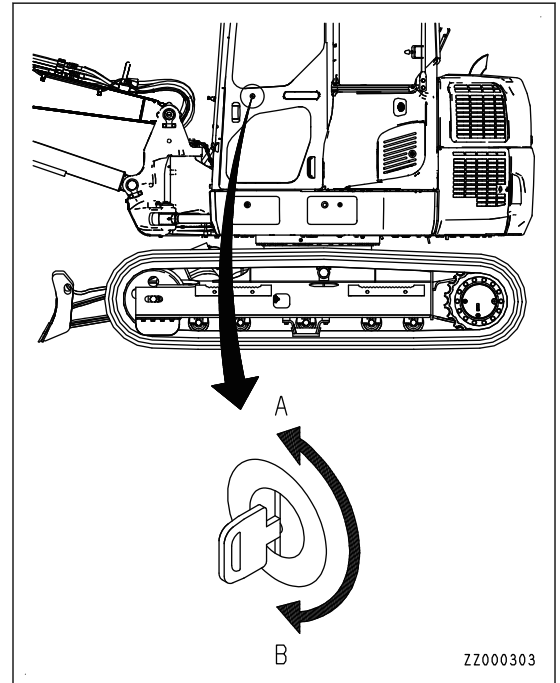

### Lock

1. Close the door and insert the key into the key slot.
2. Turn the starting switch key to CLOSE position (B), then remove the key.

# HANDLE AIR CONDITIONER

## NOTICE

- When running in the air conditioner, always start with the engine running at low speed. Never start the air conditioner when the engine is running at high speed. It will cause failure of the air conditioner.
- If water gets into the control panel or sunlight sensor, it may lead to unexpected failure, take care not to let water get on these parts. In addition, never bring any open flame near these parts.
- For the auto function of the air conditioner to work properly, always keep the sunlight sensor clean and do not leave anything around the sunlight sensor that may interfere with its sensor function.
- When the air conditioner is not being used every day, to prevent loss of the film of oil at various parts, run the air conditioner with the engine at low speed from time to time and perform cooling or dry heating for several minutes.
- When the temperature inside the cab is low, the air conditioner may not work. In this case, circulate recirculation air to warm the inside of the cab. After that, turn the air conditioner switch ON, the air conditioner will work.
- If any abnormality is detected in any equipment or sensor used on the air conditioner, the air conditioner system caution lamp lights up on the monitor screen. If the air conditioner system caution lamp lights up, ask your Komatsu distributor for inspection and repair.

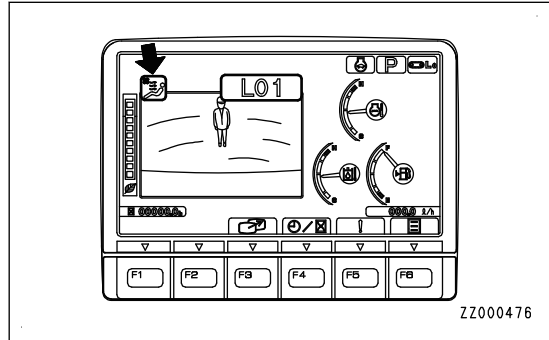

## VENTILATION

- When running the air conditioner for a long time, turn the lever to FRESH position once an hour to perform ventilation and cooling.
- If you smoke when the air conditioner is on, the smoke may hurt your eyes. In such case, open the window and turn the lever to FRESH for a while for ventilation and cooling to drive smoke out.

## TEMPERATURE CONTROL

For reasons of health, the optimum setting for cooling is considered to be when it feels slightly cool (5 to 6 °C {9 to 10.8 °F} ) lower than the ambient temperature) when you enter the cab.

Be extremely careful to select the appropriate temperature.

**EXPLANATION OF AIR CONDITIONER EQUIPMENT**

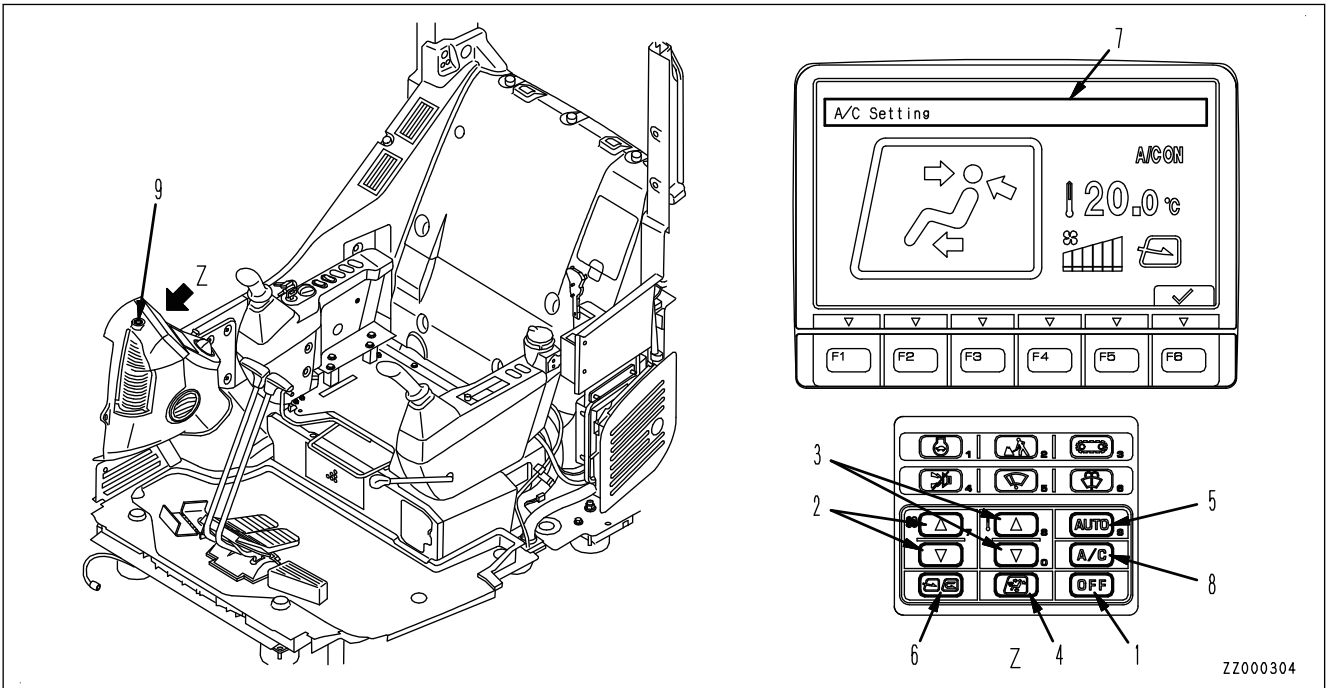

(1) OFF switch

(2) Fan switch

(3) Temperature control switch

(4) Vent selector switch

(5) Auto switch

(6) FRESH/RECIRC air selector switch

(7) Monitor

(8) Air conditioner switch

(9) Sunlight sensor

**OFF SWITCH**

This switch is used for stopping the fan and air conditioner.

**REMARK**

Even if this OFF switch is pressed, the monitor screen does not switch to the air conditioner adjustment screen.

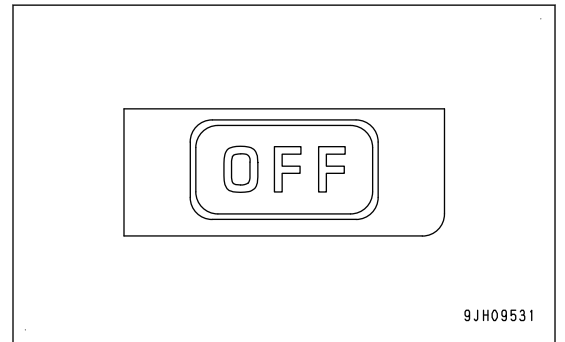

9JH09531



### FAN SWITCH

You can adjust the air flow by using the fan switch.

The air flow can be adjusted to 6 levels.

- Press the  $\Delta$  switch to increase the air flow; press the  $\nabla$  switch to decrease the air flow.
- During auto operation, the air flow is automatically adjusted.

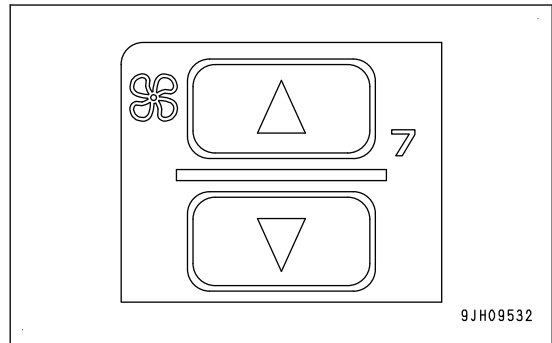

### Monitor display and air flow

Monitor display	Air flow rate
	Air flow "low"
	Air flow "medium 1"
	Air flow "medium 2"
	Air flow "medium 3"
	Air flow "medium 4"
	Air flow "high"

### TEMPERATURE CONTROL SWITCH

Use the temperature control switch to adjust the temperature inside the cab. The temperature can be set between 18 °C {64.4 °F} and 32 °C {89.6 °F}.

- Press the  $\Delta$  switch to raise the set temperature; press the  $\nabla$  switch to lower the set temperature. The set temperature is indicated on the display monitor.
- The temperature is generally set at 25 °C {77 °F}.
- The temperature can be set in stages of 0.5 °C {0.9 °F}.

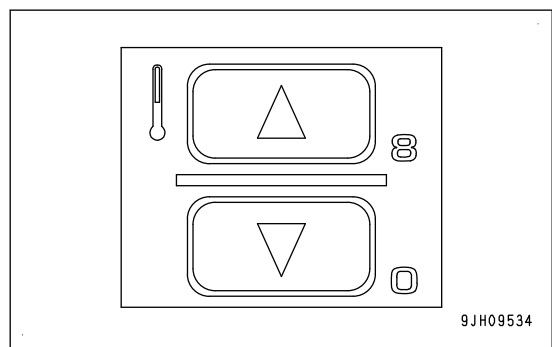

### Monitor display and function

Monitor display	Set temperature
18.0 °C {64.4 °F}	Max. cooling
18.5 to 31.5 °C {65.3 to 88.7 °F}	Adjusts temperature inside cab to set temperature
32.0 °C {89.6 °F}	Max. heating

**REMARK**

If the mode is set to auto mode and the temperature setting is set to 18.0 °C {64.4 °F} or 32.0 °C {89.6 °F} , the air flow from the fan is always set to HIGH and does not change even when the temperature reaches the set value.

**VENT SELECTOR SWITCH**

Use vent selector switch to select the vents.

- When vent selector switch is pressed, the arrow display on the monitor switches and air blows out from the vents displayed.
- During automatic operation, the vents are automatically selected.

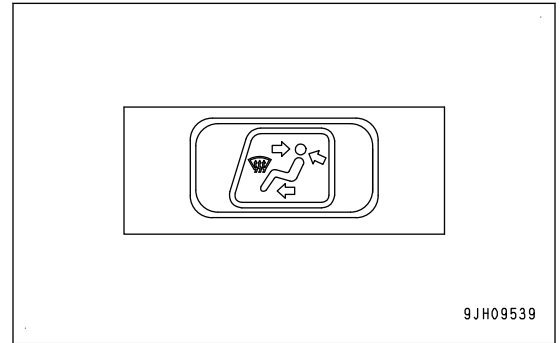

(A): Rear vent (2 places)

(B1): Face vent (1 place)

(B2): Foot vent (1 place)

(C): Foot vent (1 place)

(D): Front window glass vent (2 places)

Air blows out from the vents marked with ○.

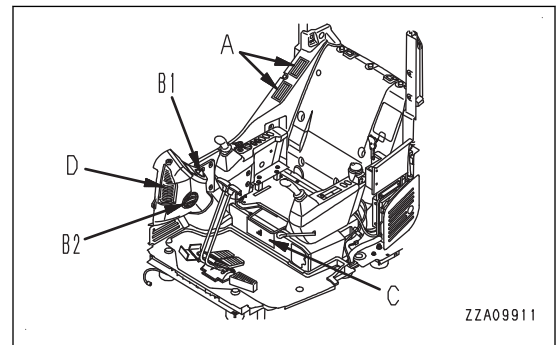

Monitor display	Air vent mode	Vent				Remarks
		(A)	(B)	(C)	(D)	
	Front and rear vents	○	○			-
	Front, rear, and foot vents	○	○	○		-
	Foot vent			○		-
	Foot vent Defroster vent	○		○	○	Not selected in auto mode
	Defroster vent	○			○	Not selected in auto mode

### AUTO SWITCH

Use the auto switch for automatic selection of the air flow, vents, and air source (FRESH/RECIRC) according to the set temperature.

- Press this switch, then use temperature control switch (1) to set the temperature, and run the air conditioner under automatic control.
- When switching from automatic operation to manual operation, it is possible to use the switches to select the vents and air source (FRESH/RECIRC).

### REMARK

When Auto Mode is selected, if the set temperature is set to 18.0 °C {64.4 °F} or 32.0 °C {89.6 °F}, the air flow is always set to High, but this is not a problem.

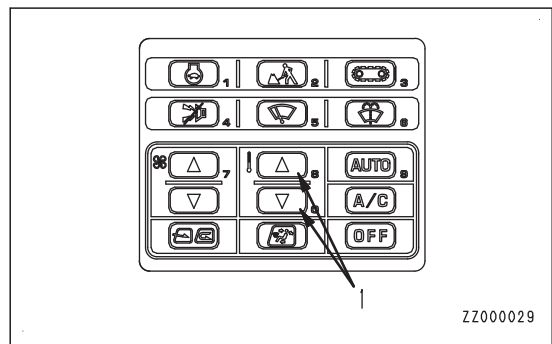
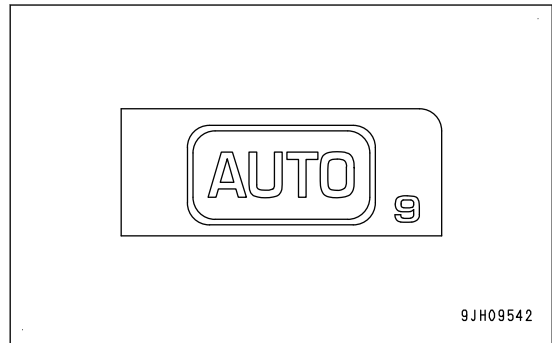

### FRESH/RECIRC AIR SELECTOR SWITCH

Use FRESH/RECIRC air selector switch to switch the air source between recirculation of the air inside the cab and intake of fresh air from the outside.

During automatic operation, the selection of inside air (RECIRC) and outside air (FRESH) is performed automatically.

#### RECIRC

Outside air is shut off and only air inside the cab is circulated.

Use this setting to perform rapid cooling of the cab or when outside air is dirty.

#### FRESH

Outside air is taken into the cab.

Use this setting to take in fresh air or to demist the window glass.

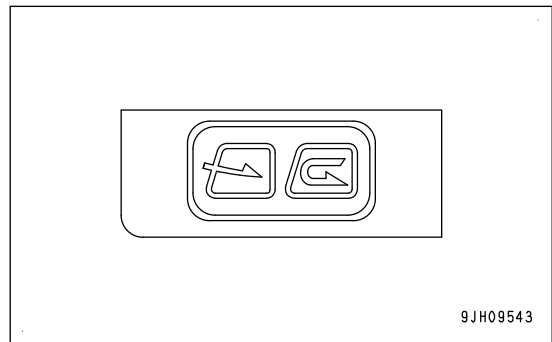

### DISPLAY MONITOR

"A/C Setting" (air conditioner setting) screen of monitor (7) indicates the state of temperature setting (a), air flow (b), and vents (c).

When OFF switch is pressed, the display of temperature setting (a) and air flow (b) goes out, and operation stops.

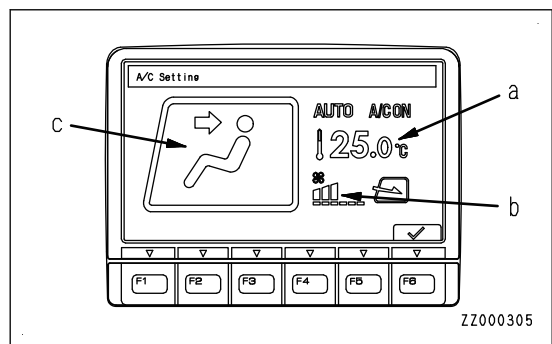

## AIR CONDITIONER SWITCH

Use air conditioner switch for turning the air conditioner (cooling, dry heating) ON or OFF.

- Press air conditioner switch when the fan is operating (when display (b) is shown on the display monitor). The air conditioner is switched ON and starts to work. Press the switch again to stop the air conditioner.
- Air conditioner cannot be operated while the fan is stopped.

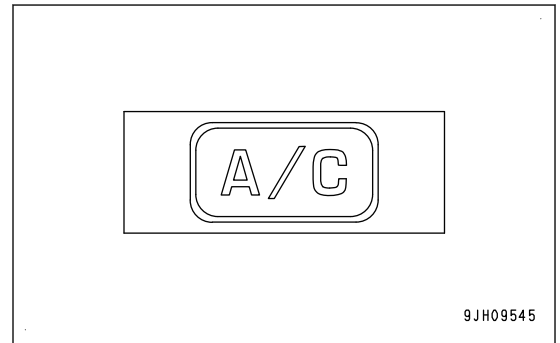

## SUNLIGHT SENSOR

Sunlight sensor automatically adjusts the flow of air from the vents to match the strength of the sun's rays. In addition, it automatically detects changes in the temperature inside the cab caused by changes in the strength of the sun's rays beforehand and automatically adjusts the temperature.



### METHOD FOR OPERATING AIR CONDITIONER

The air conditioner can be operated automatically or manually. Select the method of operation as desired.

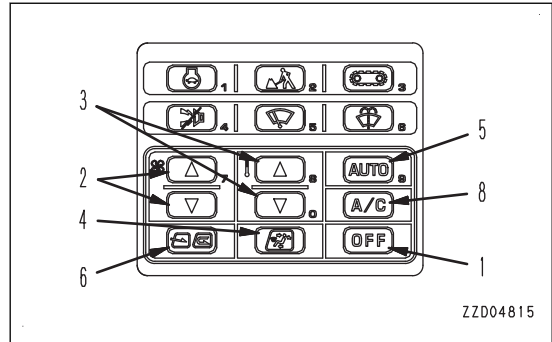

### METHOD FOR AUTOMATIC OPERATION

1. Press auto switch (5) to turn it ON.

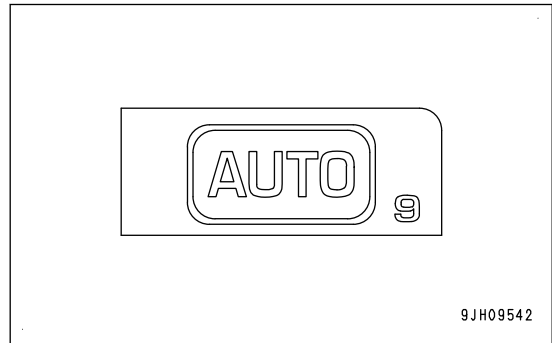

Set temperature (a) and air flow rate (b) are displayed on "A/C Setting" screen.

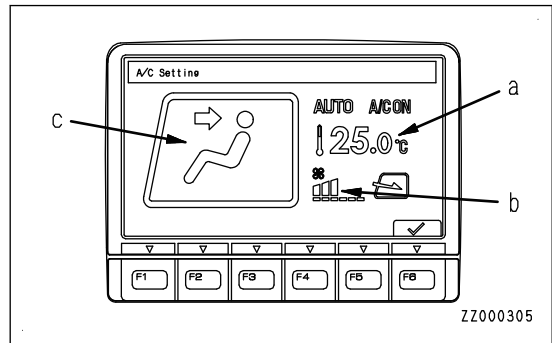

2. Use temperature control switch (3) to set to the desired temperature.

The air flow, combination of vents, and selection of fresh or recirculated air is automatically selected according to the set temperature, and the air conditioner is operated automatically to provide the set temperature.

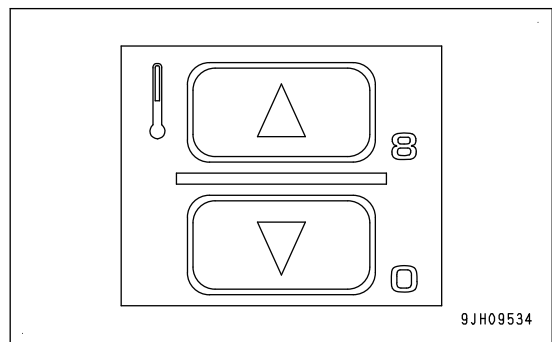

### REMARK

When (d) or (e) is displayed in vent (c), if the engine coolant temperature is low, the air flow is automatically limited to prevent cold air from blowing out.

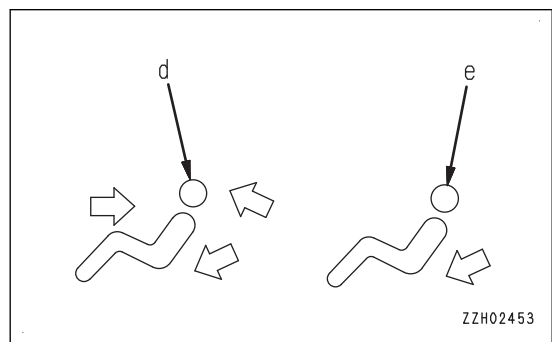

**METHOD FOR STOPPING AUTOMATIC OPERATION**

Press OFF switch (1).  
The air conditioner stops.

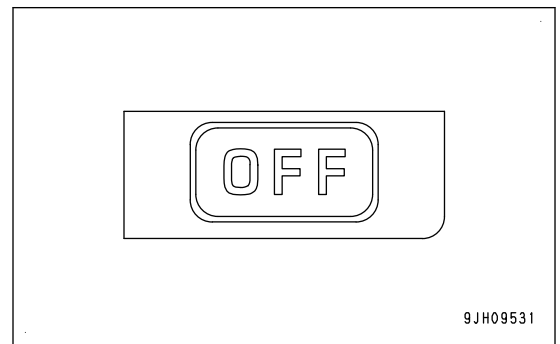
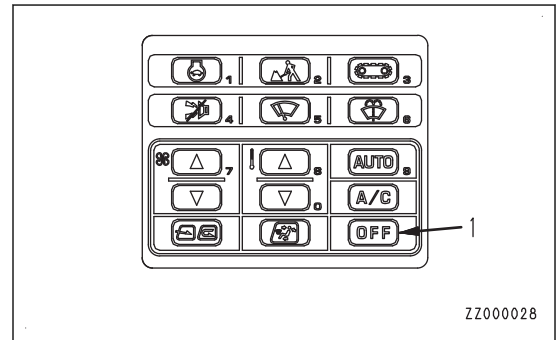

## METHOD FOR MANUAL OPERATION

1. Press fan switch (2) and adjust the air flow.

At this time, check that set temperature (a) and air flow rate (b) are displayed on "A/C Setting" screen of the monitor.

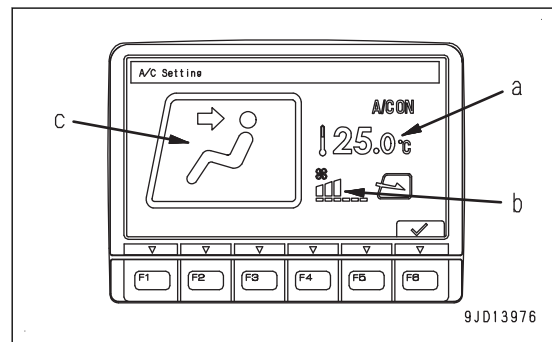
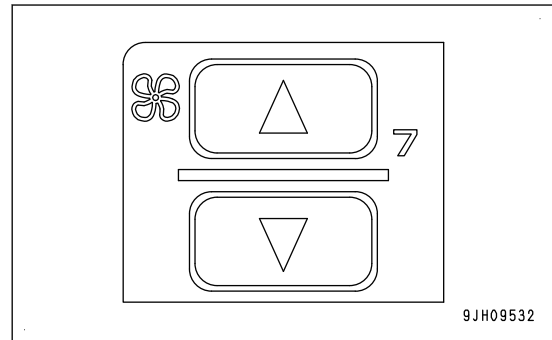

2. Press air conditioner switch (8) to turn it ON.

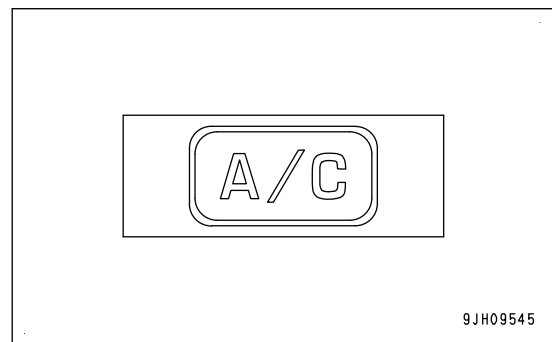

3. Press temperature control switch (3) to select desired temperature.

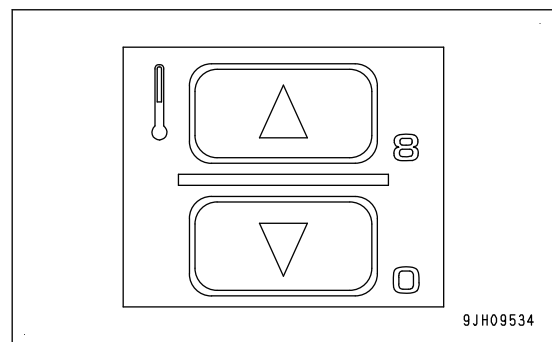

- Press vent selector switch (4) and select the desired vents.  
At this time, the display of vent (c) on "A/C Setting" screen of the monitor changes according to the selection.

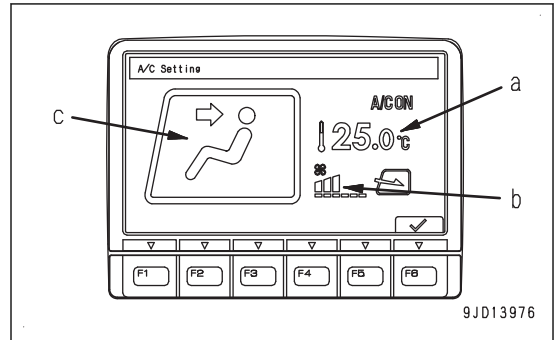
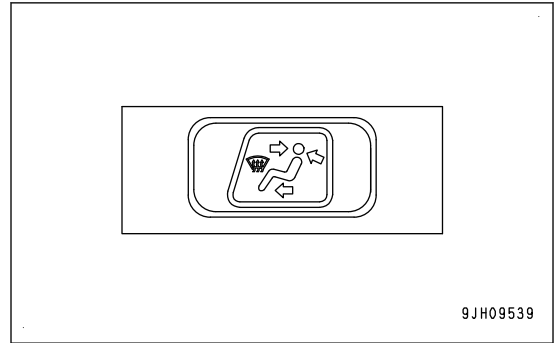

- Press FRESH/RECIRC selector switch (6) and select recirculation of the air inside the cab (RECIRC) or intake of fresh air from outside (FRESH).

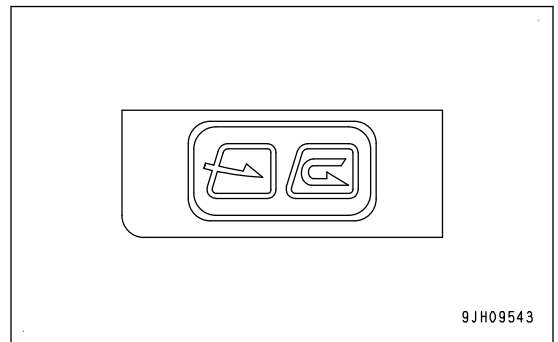

**METHOD FOR STOPPING MANUAL OPERATION**

Press OFF switch (1).  
The air conditioner stops.

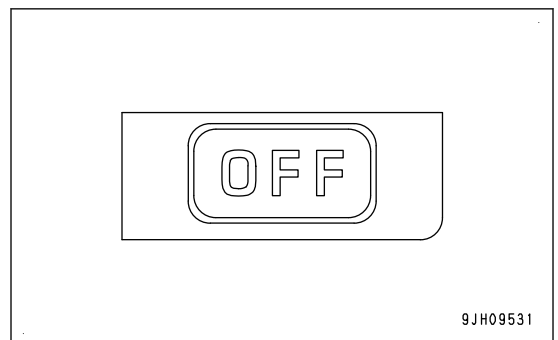
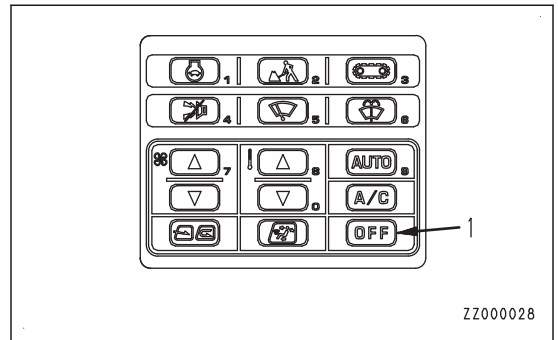



**METHOD FOR OPERATING WITH COLD AIR TO FACE AND WARM AIR TO FEET**

To operate with cold air blowing to the face and warm air blowing to the feet, set as follows.

1. Press fan switch (2) and adjust the air flow.

At this time, check that set temperature (a) and air flow rate (b) are displayed on "A/C Setting" screen of the monitor.

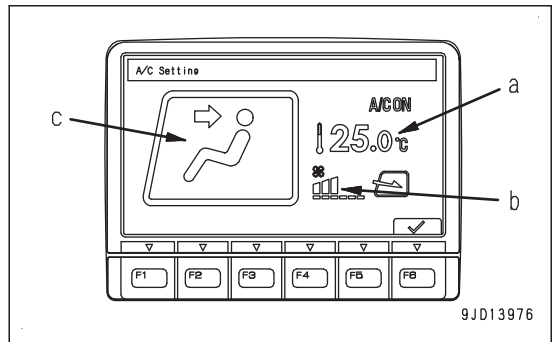
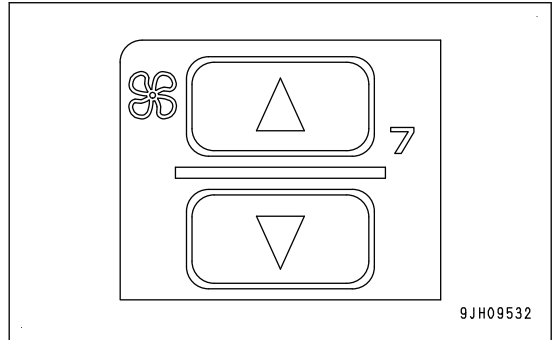

2. Press vent selector switch (4) and set the vent display as shown in the figure.

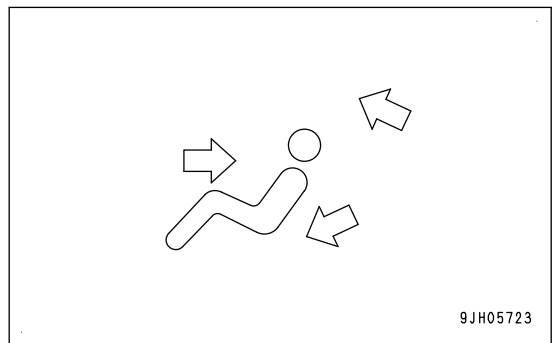

3. Press air conditioner switch (8) to turn it ON.

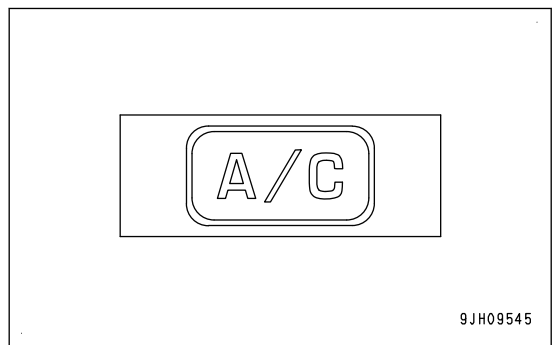

4. Adjust fan switch (2), temperature control switch (3) and FRESH/RECIRC selector switch (6) to the desired positions.

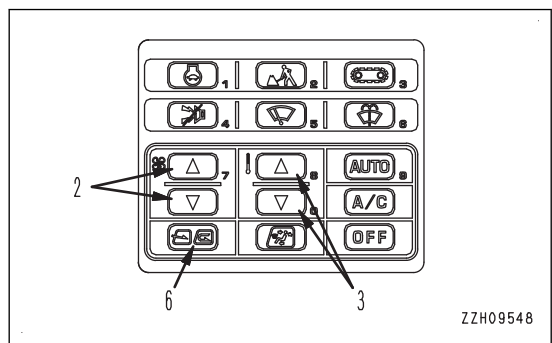

**METHOD FOR OPERATING DEFROSTER**

1. Press fan switch (2) and adjust the air flow rate.  
At this time, check that set temperature (a) and air flow rate (b) are displayed on "A/C Setting" screen of the monitor.

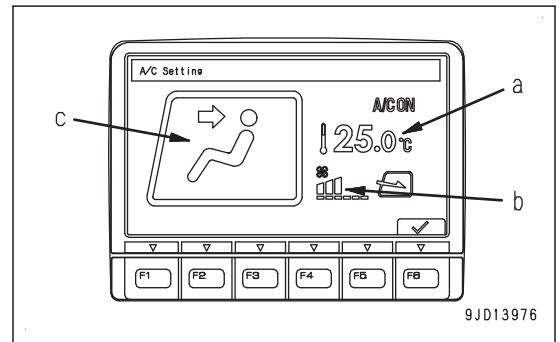
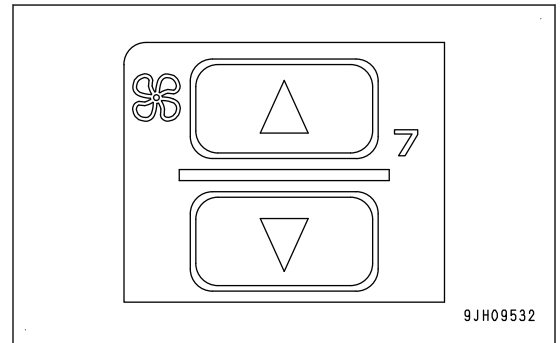

2. Press vent selector switch (4) and set the vent display to (f) or (g) shown in the figure.

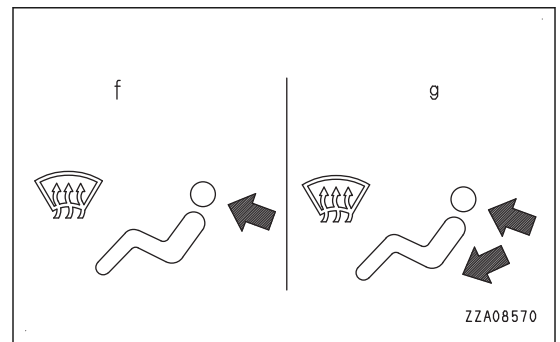
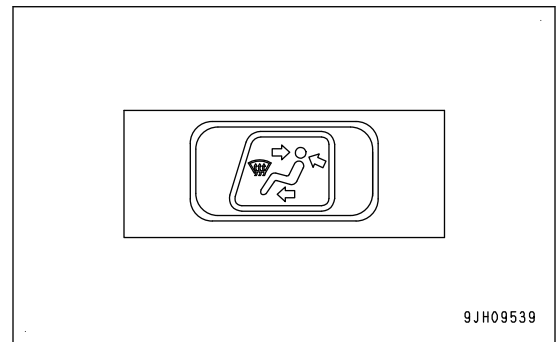

3. Press FRESH/RECIRC selector switch (6) and set it to FRESH mode.

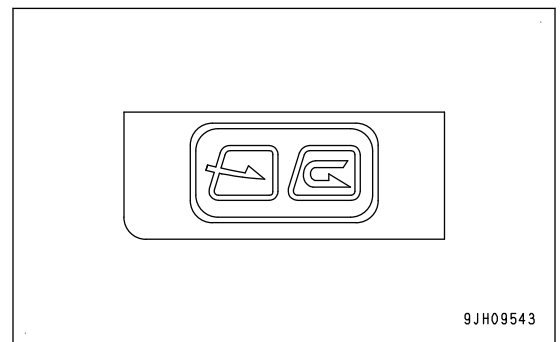

4. Press temperature control switch (3) and set temperature to 32.0 of maximum heating.

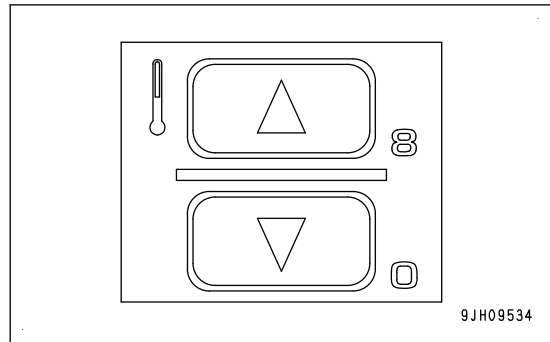

5. Adjust vents (A), (B1), and (B2) so that the air blows onto the window glass.  
(Vents (C) and (D) are fixed and cannot be adjusted.)

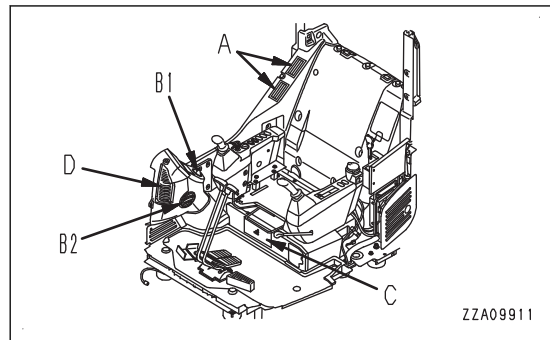

6. When operating in the rainy season or when it is desired to remove the mist from the window glass or to dehumidify the air, press air conditioner switch (8) to turn it ON.

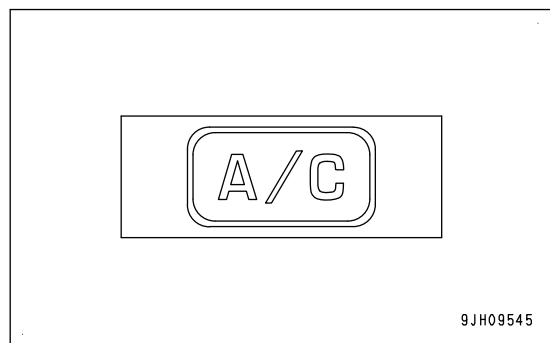

## HANDLE RADIO

- To ensure safety, always keep the sound to a level where it is possible to hear outside sounds during operation.
- If water gets into the speaker case or radio, it may lead to an unexpected failure, so be careful not to get water on the equipment.
- Do not wipe the display or buttons with solvent such as benzene or thinner. Wipe with a dry soft cloth.
- When the battery disconnect switch is turned to OFF position or the power for the machine is off at the replacement of the battery, the clock may be initialized. In such a case, set it again.

## EXPLANATION OF RADIO EQUIPMENT

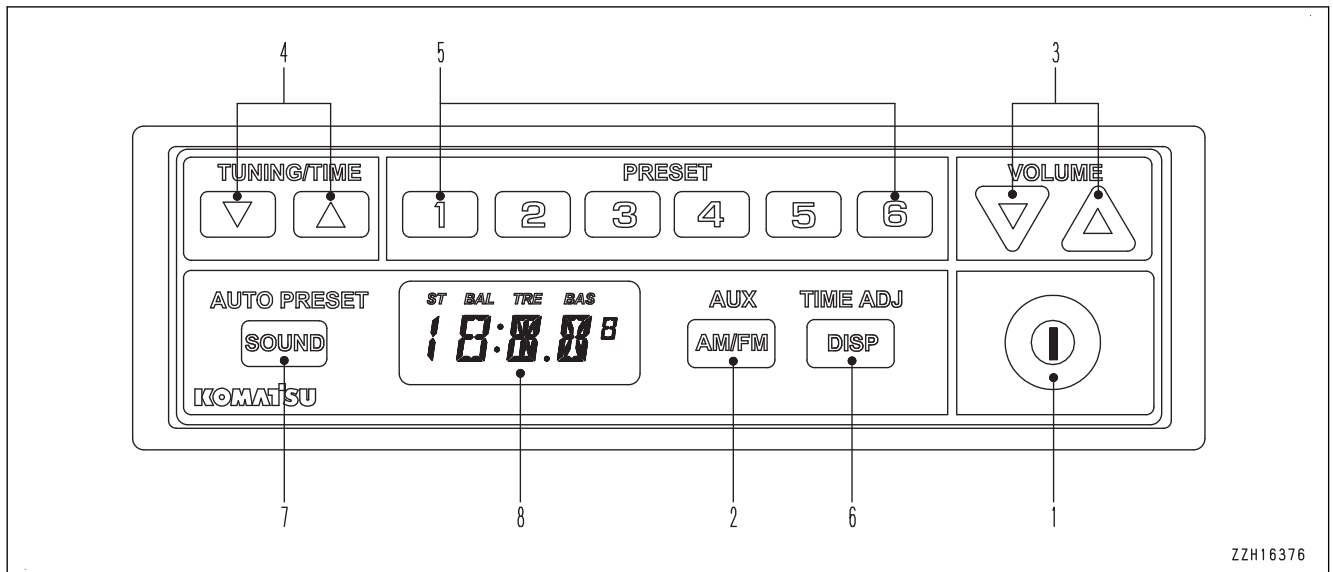

- |                                   |                             |
|-----------------------------------|-----------------------------|
| (1) Power button                  | (5) Preset button           |
| (2) Band/AUX selector button      | (6) Display selector button |
| (3) Volume control button         | (7) Sound control button    |
| (4) Tuning/time adjustment button | (8) Display                 |

### POWER BUTTON

Press the power button to supply the power to the radio and the frequency is shown on display. As long as AUX is selected, display indicates AUX on it. Press the button again to turn the power off.

### BAND/AUX SELECTOR BUTTON

Press band/AUX selector button to select the desired band or AUX.

Each time the button is pressed, the band changes FM → AM → AUX → FM...

### VOLUME CONTROL BUTTON

Use the volume control button to control the volume.

Press the  $\Delta$  button, and the volume increases. Press the  $\nabla$  button, and the volume decreases. The range for the volume is 0 to 32.

Hold down this button, and you can change the volume continuously.

### TUNING/TIME ADJUSTMENT BUTTON

Use the tuning/time adjustment button to select frequency and step for sound adjustment and to adjust time.

### PRESET BUTTON

If you register desired stations to the preset button beforehand, you can select each station by touching this button once.

It is possible to preset 6 stations each for both AM and FM.

### DISPLAY SELECTOR BUTTON

Use the display selector button to change frequency and clock shown on the display.

Each time you press this button, frequency, clock and band are shown on the display in this order.

If 1.5 seconds passes while a band is shown, a frequency will be displayed.

As long as AUX is selected, this button alternately switches the display between AUX and the clock.

### SOUND CONTROL BUTTON

Press the sound control button, and the sound adjustment is ready.

Each time this button is pressed, BAL (Balance), TRE (Treble) and BAS (Bass) will be selected in this order.

If this button is pressed while BAS is displayed, the sound adjustment will be canceled.

### DISPLAY

- (A): Band name, "AUX", frequency, clock and other character/numeric information are displayed.
- (B): Frequencies are displayed at steps of 50 kHz in certain areas.
- (C): Lights up when a stereo broadcasting is heard while a FM station is selected.
- (D): Lights up at the time of balance adjustment in the sound adjusting condition.
- (E): Lights up at the time of treble adjustment in the sound adjusting condition.
- (F): Lights up at the time of bass adjustment in the sound adjusting condition.

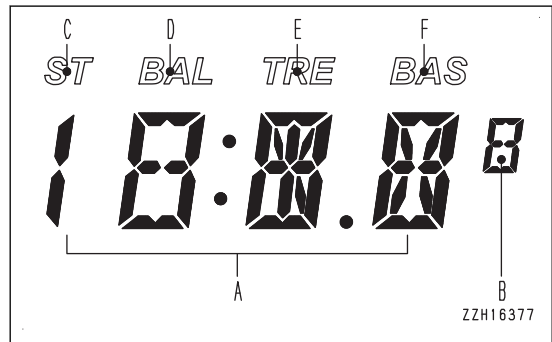

## AUX

### NOTICE

- A stereo miniature plug can be connected.  
Read the instruction manual of the equipment to connect carefully.
- As a power source, use the battery attached to the equipment to connect.  
If you use an electric power supply installed to the machine, the noise may occur.
- The noise may occur if you pull out the input plug when AUX is selected, or if you push in or pull out the plugs of the equipment to connect.

You can hear the sound through the speaker of the machine when you connect a commercially available portable audio equipment to the machine.

1. Open cap (A) at the rear right of the operator's seat.
2. Connect a portable audio equipment by using an commercially available audio cable.

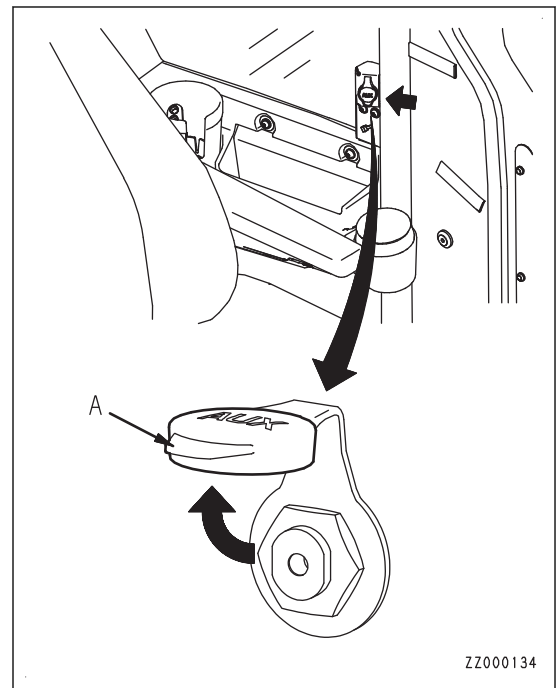

3. Press band/AUX selector button (1) to select "AUX".

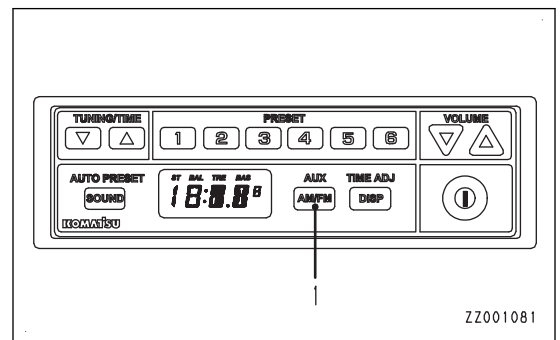

## METHOD FOR CONTROLLING RADIO

### METHOD FOR ADJUSTING FREQUENCY

1. Press band/AUX selector button (1) and select FM or AM.
2. Press tuning/time adjustment button (2) to adjust the frequency.

- Press the  $\Delta$  button, and the frequency increases; press the  $\nabla$  button, and the frequency decreases.
- Hold down the  $\Delta$  button, and the frequency increases continuously; hold down the  $\nabla$  button, and the frequency decreases continuously.
- Hold down the  $\Delta$  button and release it, then the frequency increases continuously. Hold down the  $\nabla$  button and release it, then the frequency decreases continuously as an auto seek. When a proper frequency is picked up, the tuning automatically stops.

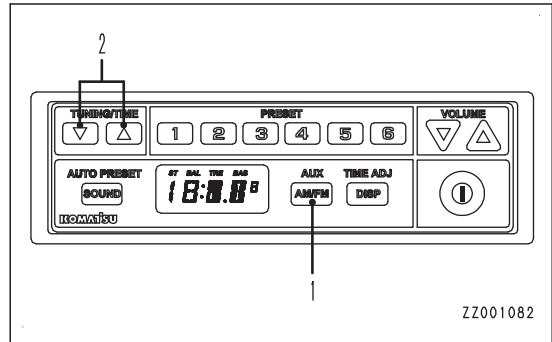

ZZ001082

### METHOD FOR ADJUSTING FREQUENCY (AUTO PRESETTING)

1. Press band/AUX selector button (1) and select FM or AM.
2. Hold down sound control button (2).

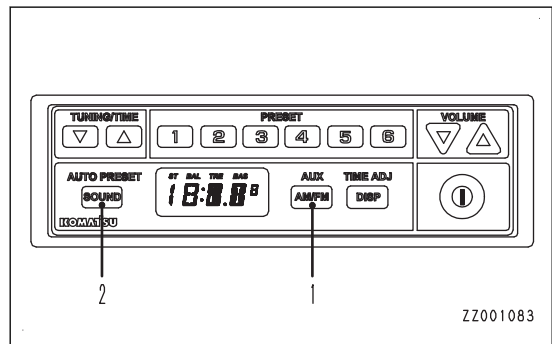

ZZ001083

When a proper frequency is picked up, it is automatically registered to preset memories 1 to 6.

### METHOD FOR CALLING PRESET

1. Press band/AUX selector button (1) and select FM or AM.
2. Press one of 1 to 6 of preset button (2).

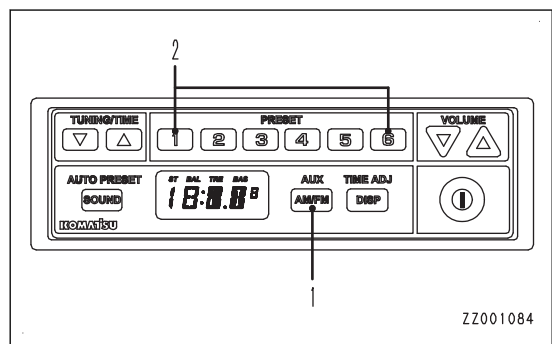

ZZ001084

The frequency registered in the preset number of the pressed button is called up and received.

“Example”

While a frequency is displayed, press button 1 of preset button (2), and the preset number “P-1” appears on the display.

The preset number is shown for 0.5 seconds, and then the frequency is displayed.

## METHOD FOR REGISTERING PRESET

Hold down one of 1 to 6 of preset button (1) while listening to the radio.

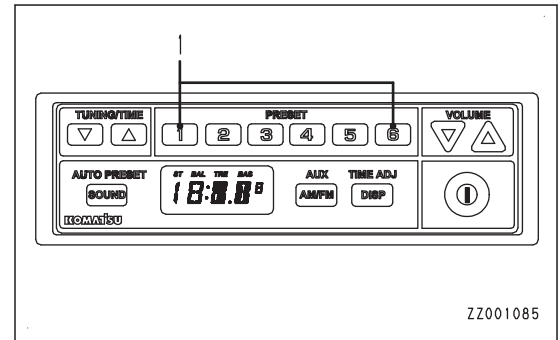

The currently received frequency is registered to the preset number corresponding to the pressed button.

“Example”

While a frequency is displayed, keep pressing button 1 of preset button (1), and the preset number “P-1” is displayed.

After the preset number flashes 3 times, the frequency is displayed and then registered to preset number “P-1”.

## METHOD FOR ADJUSTING SOUND BALANCE

1. Press sound control button (1) to light up “BAL” on the display.  
You can adjust the sound (balance).
2. Press tuning/time adjustment button (2) to adjust the sound (balance).
  - Press the  $\Delta$  button, and the speaker output on the R side increases by 1. (R1 to R7)
  - Press the  $\nabla$  button, and the speaker output on the L side increases by 1. (L1 to L7)

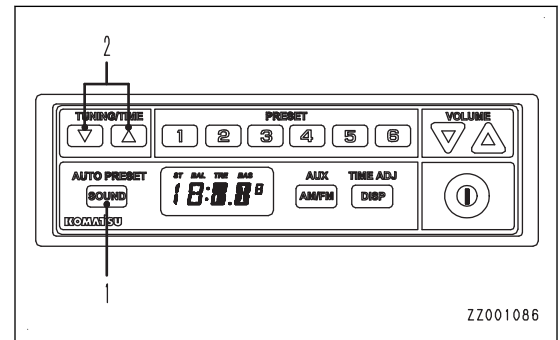

## METHOD FOR ADJUSTING HIGH REGISTER RANGE (TREBLE)

1. Press sound control button (1) to light up “TRE” on the display.  
You can adjust the high register range (treble) of the sound.
2. Press tuning/time adjustment button (2) to adjust the high register range (treble).
  - Press the  $\Delta$  button, and the high register range (treble) level increases by 1. (Maximum + 7)
  - Press the  $\nabla$  button, and the high register range (treble) level decreases by 1. (Minimum - 7)

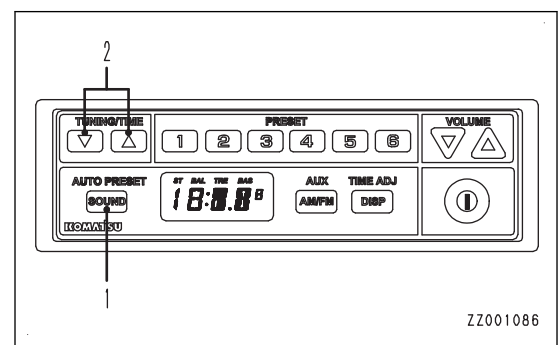



### METHOD FOR ADJUSTING LOW REGISTER RANGE (BASS)

1. Press sound control button (1) to light up “BAS” on the display.  
You can adjust the low register range (bass) of the sound.
2. Press tuning/time adjustment button (2) to adjust the low register range (bass).
  - Press the  $\Delta$  button, and the low register range (bass) level increases by 1. (Maximum + 7)
  - Press the  $\nabla$  button, and the low register range (bass) level decreases by 1. (Minimum - 7)

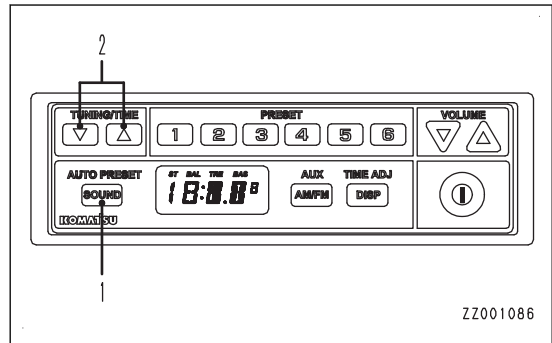

### METHOD FOR ADJUSTING CLOCK

1. Press display selector button (1) to display the clock.
2. Hold down display selector button (1) to flash the “HOUR” display portion.  
You can adjust the hour.
3. Press tuning/time adjustment button (2) to adjust the hour.
  - If you press  $\Delta$  button, “HOUR” display increases by 1.
  - If you press  $\nabla$  button, “HOUR” display decreases by 1.
4. Press display selector button (1) to flash the “MINUTE” display portion.  
You can adjust the minute.
5. Press tuning/time adjustment button (2) to adjust the minute.
  - If you press  $\Delta$  button, “MINUTE” display increases by 1.
  - If you press  $\nabla$  button, “MINUTE” display decreases by 1.
6. Press display selector button (1) to cancel time adjustment.  
The screen returns to clock display.

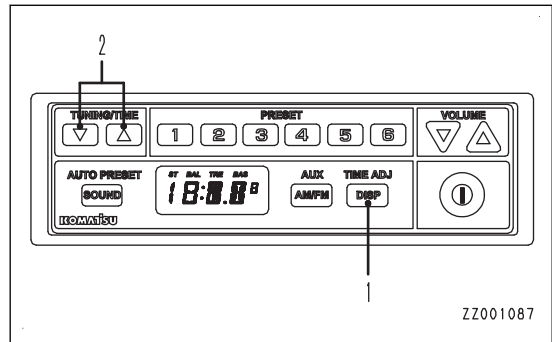

### STOW ANTENNA

Before transporting the machine putting it inside a building, store the antenna to prevent any interference.

1. Loosen antenna mounting bolt (1) and store the antenna at position (A).
2. After storing the antenna, tighten bolt (1).

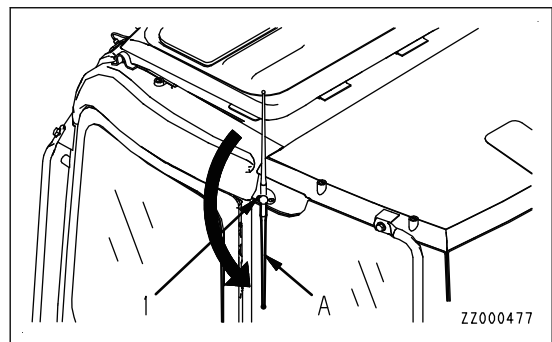

## HANDLE ROAD LINERS AND RUBBER SHOES

(Road liner, rubber shoe specification)

### RECOMMENDED USE OF ROAD LINERS AND RUBBER SHOES

The road liner and rubber shoes have good features which the steel shoes does not have. However, if they are used similarly to the steel shoes, their features are not used fully.

Avoid using the road liner forcibly, depending on the condition of the site and contents of work.

### COMPARISON OF ROAD LINERS, RUBBER SHOES AND STEEL SHOES

	Road liner	Rubber shoe	Steel shoe
Less vibration	◎	◎	△
Smooth travel (No creak)	○	◎	○
Small sound	◎	◎	△
No risk of damaging pavement	◎	◎	△
Easy handling	△	◎	△
Resistant to damage	○	△	◎
Large traction force	◎	◎	◎

◎: Very good

○: Good

△: Fair

The road liner and rubber shoe have many advantages for the performance unique to their material, but their strength is an weak point. Accordingly, you can extend the service life of the road liner and rubber shoe and use their advantages fully by understanding their features and observing the prohibited matter and precautions for handling.

### WARRANTY OF ROAD LINERS AND RUBBER SHOES

The warranty does not cover any damage caused by a customer's mistake, including neglect of check and maintenance of the track tension, disregard of prohibited matter such as "operation on the corners of a steel plate, a U-bend trap, a concrete block, reinforcing bars, scrap steel, etc. which can cut the road liner" and precautions.

## PRECAUTIONS WHEN USING ROAD LINERS AND RUBBER SHOES

### Prohibited operations

Do not perform the following work.

- If the machine is operated or swung on crushed stones, very irregular hard rock-bed, reinforcing bars, scrap steel, edges of steel plates, the road liner and rubber shoes can be damaged.
- In a riverbed, etc. where there are many large boulders, the road liner and rubber shoes may be damaged by stones caught in them and may come off the rollers. If the machine is used to doze forcibly while the shoes slip, the service lives of the road liner and rubber shoes are shortened.
- Take care that oil, fuel, or chemical solvent does not stick to the road liner and rubber shoe. If any of them sticks, wipe it off immediately. Do not travel on a road where oil, etc. is accumulated.
- When storing the machine for a long period (3 months or more), store it indoors to avoid direct sunlight and rain.
- Do not drive the machine into a high temperature place such as a bonfire, steel plate exposed to the hot sun, newly spread asphalt, etc.
- If the machine moves on only the track on either side while the track on the other side is raised with the work equipment, the rubber shoes may come off the rollers or may be damaged.
- If the rubber parts of the road liner are worn and damaged and the mounting bolt heads are damaged, replace the shoes with new ones immediately. If the head of a bolt is crushed, that bolt cannot be removed.
- When installing the road liner, always install to all the links of the right and left tracks. If it is installed partially or to only one portion, its service life is shortened remarkably.

### Precautions during operation

When operating, observe the following.

- Do not make a pivot turn on a concrete road since rubber marks are made on the road surface.
- Avoid turning sharply whenever possible, since that can cause early wear and chipping of the road liner and rubber shoe.
- Avoid turning on a large level difference. When riding over a level difference, travel perpendicularly to it to prevent the shoes from coming off.
- Once you raise the machine by using the work equipment, lower it slowly.
- Avoid handling crushed and oily material (cakes of soybean, corn, rapeseed, etc.) or wash the machine with water after the work.
- Avoid handling salt, ammonium sulfate, potassium chloride, potassium sulfate, and triple superphosphate or wash the machine with water after the operation since they corrode the adhesive of the core metal.
- Do not use the road liner on seashore since the adhesive of the core metal is corroded by the salt.
- When the road liner or rubber shoes is used to handle salt, sugar, wheat, soybeans, etc., if it has a deep cut, rubber chips may be mixed in the handled material. To prevent this, repair any cut before using.
- Do not rub the road liner against concrete ridges, walls, etc. during operation.
- The road liner and rubber shoes are very slippery on wet steel plates, snow-covered or frozen road surfaces, or clay soil. Beware of slipping and skidding when traveling or working on a slope.
- If the road liner and rubber shoes are used in an extremely cold district, their characteristics change and their service lives are shortened accordingly.
- Use the road liner in a temperature range from -25 to 65 °C {-13 to 149 °F} .  
Use the rubber shoes in a temperature range from -25 to 55 °C {-13 to 131 °F} due to the properties of rubber.
- Take care not to damage the road liner and rubber shoes with the bucket during operation.
- Keep the rubber shoe tension proper to prevent the rubber shoes from coming off the rollers. If the tension is low, the rubber shoes comes off under the following conditions.  
Even if the tension is proper, take extreme care during the work.

1. Do not steer the machine on curb stones or rocks where there are level differences (approximately 20 cm {8 in} or more). When riding over a level difference, drive at right angles to it.

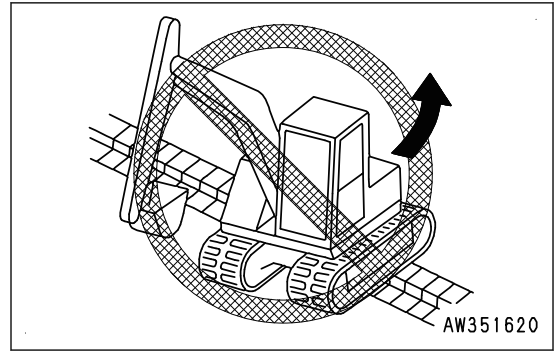

2. When traveling uphill in reverse do not steer on the line between the level ground and the slope. If it is obliged to steer while traveling uphill, steer slowly.

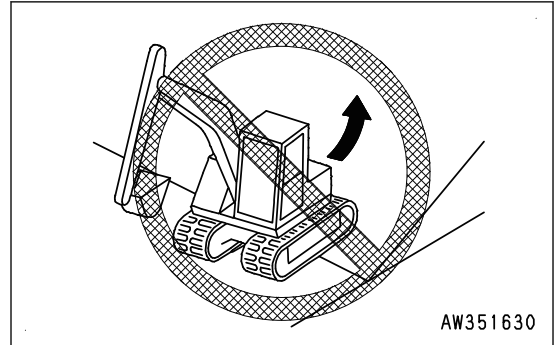

3. Do not travel with either track raised on a slope or convex ground surface (with the machine leaning approximately 10 deg. or more) and the other track on the level ground. Travel with both tracks on the same level to protect the road liner and rubber shoes from being damaged.

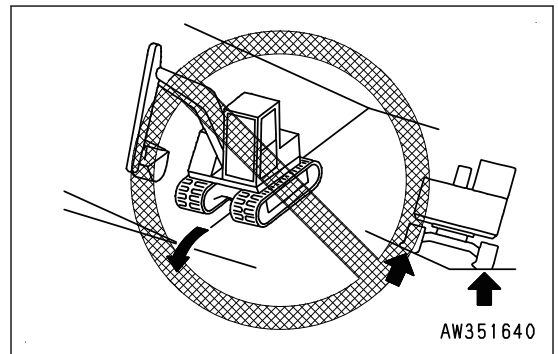

4. The rubber shoes sag in 1 to 3 above. Do not steer in the postures shown in the figure.

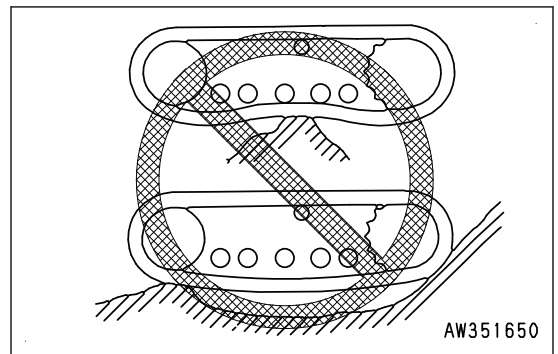

**Mechanism that rubber shoe comes off**

1. When the machine rides over a level difference, a clearance is made between track rollers (1) and rubber shoes (2). Rubber shoes (2) can come off even under this condition.

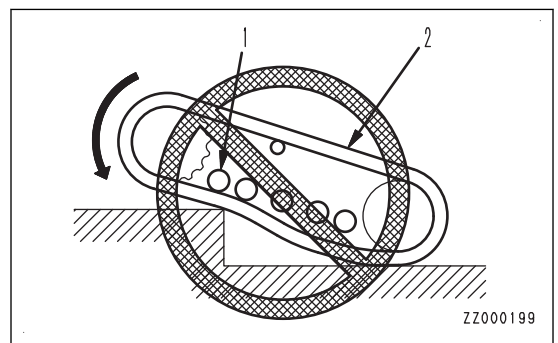

2. When the machine travels further in reverse, a clearance is made between track rollers (1), idler (3), and rubber shoes (2).

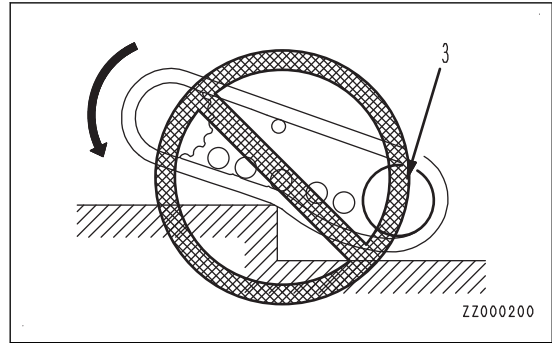

3. The rubber shoes come off in the following cases.
- When the machine is steered while the rubber shoes cannot move sideways because of a material to ride over or another thing.
  - When the idler or track rollers deviate from the core metal because of misalignment of the rubber shoes.
    - (A): Frame side
    - (B): Rubber shoe side

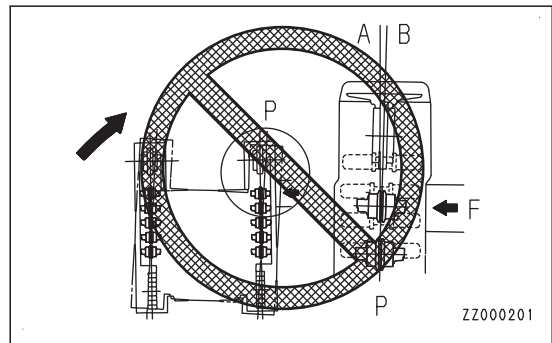

- When the machine travels in reverse under the condition shown in the figure.

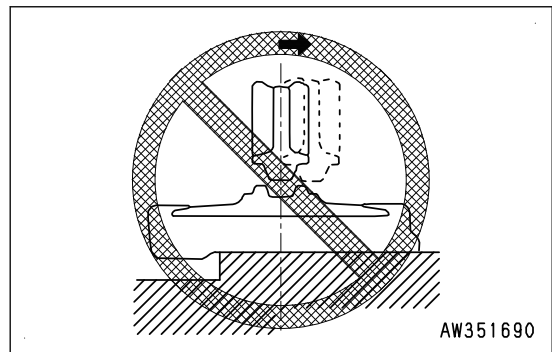

- When the machine is steered under the condition shown in the figure.

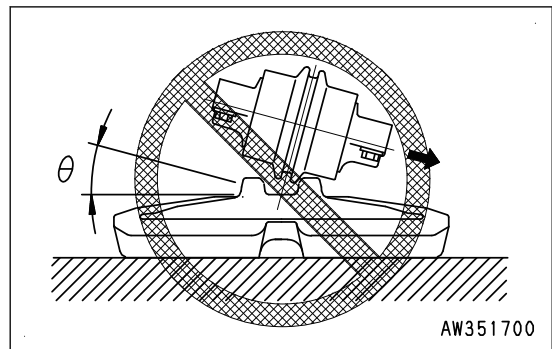

# TRANSPORTATION

## PRECAUTIONS FOR TRANSPORTING MACHINE

When transporting the machine, observe all related laws and regulations, and be careful to assure safety.

## SELECT TRANSPORTATION METHOD

When transporting the machine, choose the transportation method in reference to the weight and dimensions of machine.

Note that the weight and dimension given in "SPECIFICATIONS" (weight and dimension) may differ according to the type of track shoe or arm, or other attachments.

## LOADING AND UNLOADING WITH TRAILER

### PRECAUTIONS FOR LOADING AND UNLOADING WITH TRAILER

#### **WARNING**

Always observe the following when loading or unloading the machine from a trailer.

- Select the firm, level ground when loading or unloading the machine.  
Maintain a safe distance from the road shoulder
- Always turn the auto-deceleration switch OFF (cancel). If the auto-deceleration switch is left ON, the machine may suddenly start moving.
- Always set the travel speed switch to low speed (Lo), run the engine at low idle, and operate the machine slowly when loading or unloading the machine.
- Perform the warming-up operation thoroughly and make sure that the engine speed is stable before performing the loading or unloading the machine.
- Never correct your steering on the ramps. There is danger that the machine may tip over.  
If necessary, drive off the ramps or back on to the trailer and correct the direction.
- On the ramps, do not operate any lever except the travel lever.
- It is dangerous to use the work equipment for loading and unloading operations. Always use ramps.
- The center of gravity of the machine shifts suddenly at the joint between the ramps and the trailer, and it is dangerous that the machine loses its balance.  
Accordingly, pass this point slowly.
- If it is necessary to swing the work equipment on the trailer platform, the footing is unstable, so be extremely careful that the machine does not tip over.  
If the work equipment is installed to the machine, pull the work equipment in, and operate slowly to prevent the machine from losing its balance.
- Position a flagman to give guidance to prevent the machine from coming off the ramps and to ensure safety in the operation.
- Always check that the sliding door of the cab is at LOCK position, regardless of whether the door is open or closed. Avoid opening or closing the door on the ramps or trailer platform because the operating effort may suddenly change.

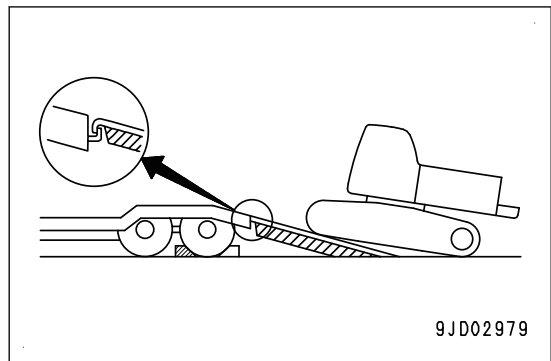
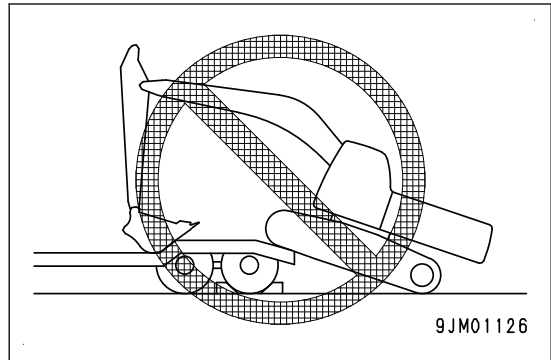

## ⚠ WARNING

Always observe the following regarding the ramps and trailer platform.

- Use ramps with ample width, length, thickness, and strength and install them with a maximum slope of 15 deg.  
When using piled soil, compact the piled soil fully to prevent the slope face from collapsing.
- Clean the machine tracks and ramps before starting in order to prevent the machine from slipping on the ramps.  
There is danger of the machine slipping if there is water, snow, grease, oil, or ice on the ramp surface.

## PROCEDURES FOR LOADING MACHINE

Load on a firm and level ground.

Maintain a safe distance from the road shoulder

1. Apply the trailer brakes securely, then put chocks (1) under the tires to prevent the trailer from moving.
2. Set right and left ramps (2) parallel to each other and equally spaced to the right and left of center (3) of the trailer. Make angle of installation (4) a maximum of 15 °.  
If the ramps bend a large amount under the weight of the machine, put blocks under the ramps to prevent them from bending.

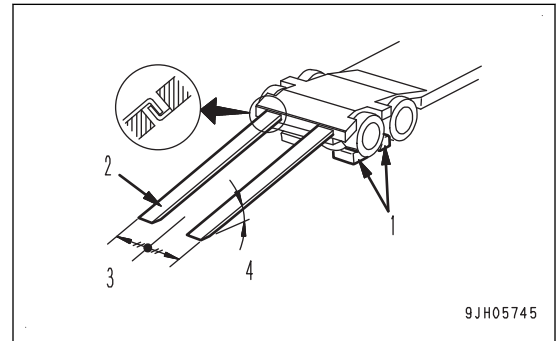

3. Turn the travel speed selector switch to low-speed travel ("Lo" lamp lights up).  
Press travel speed selector switch (5) to switch the travel speed. The travel speed ("Lo", "Hi") is displayed on travel speed display (6).
4. Turn auto-deceleration switch (7) OFF and operate the fuel control dial to set the engine to low speed.
  - Each time auto-deceleration switch (7) is pressed, it switches OFF to ON to OFF in turn.
  - When auto-deceleration switch (7) is turned OFF, the auto-deceleration pilot lamp (8) goes out.

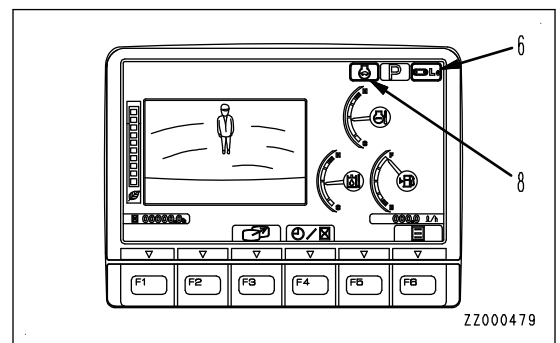
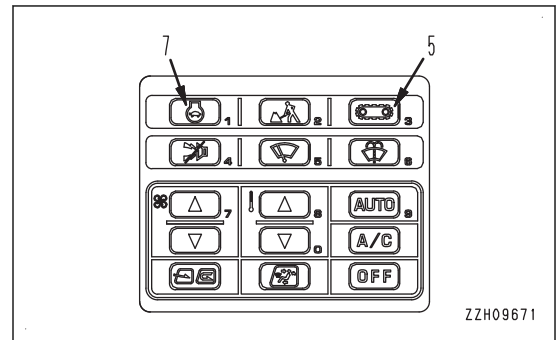



5. When loading, set the work equipment to the front of the machine and set the blade to the rear, and set the undercarriage and the upper structure in parallel.
6. Before moving the machine onto the ramps, make sure that the machine is positioned in a straight line with the ramps and that the centerline of the machine matches that of the trailer.
7. Set the travel direction toward the ramps and drive slowly.  
Lower the work equipment as far as possible without causing interference.

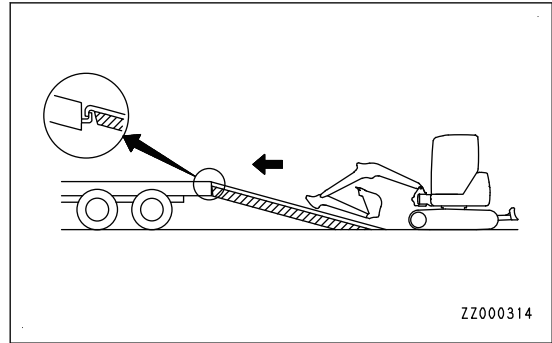

On the ramps, operate only the travel lever. Do not operate any other lever.

8. Stop the machine at the specified position and swing the upper structure slowly 180°.

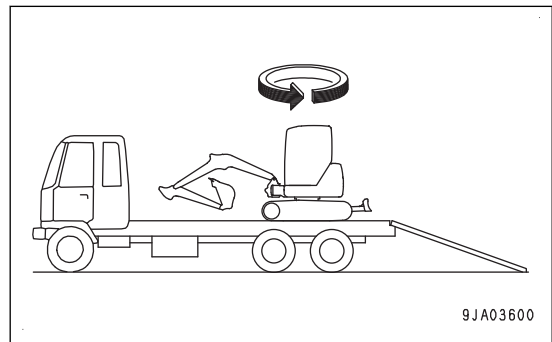

9. Stop the machine at the specified position on the trailer.
10. Lower the blade.
11. Extend the bucket and arm cylinders fully, then lower the boom slowly.

#### NOTICE

To prevent damage to the bucket cylinder during transportation, put a block under the tip of the bucket link to prevent the bucket cylinder from touching the floor.

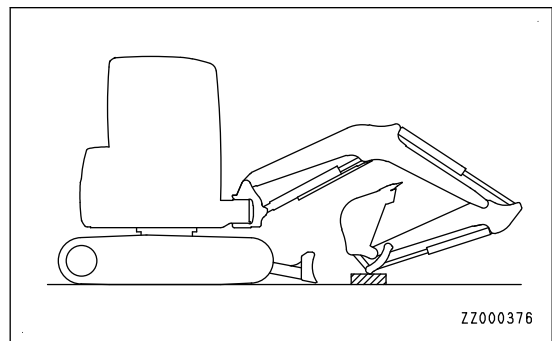

12. Set the lock lever securely to LOCK position (L).
13. Stop the engine, then remove the key from the starting switch.
14. Close all of the doors, windows, and covers.

#### NOTICE

Stow the antenna. Reassemble the mirrors (if equipped) so that they are within the width of the machine.

15. Lock the lockable doors, covers, and caps.
16. Select the way of secure the machine according to the transportation form of each territory from the following.

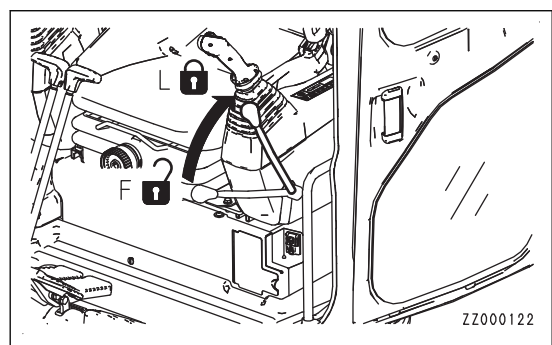

- Securing the machine when using tie-down point (1)  
Tie one end of each chain or wire rope of appropriate strength to the tie-down holes on the track frame.  
X: 50 to 100 mm {2 to 3.9 in}  
(Keep the chains off the track frame.)

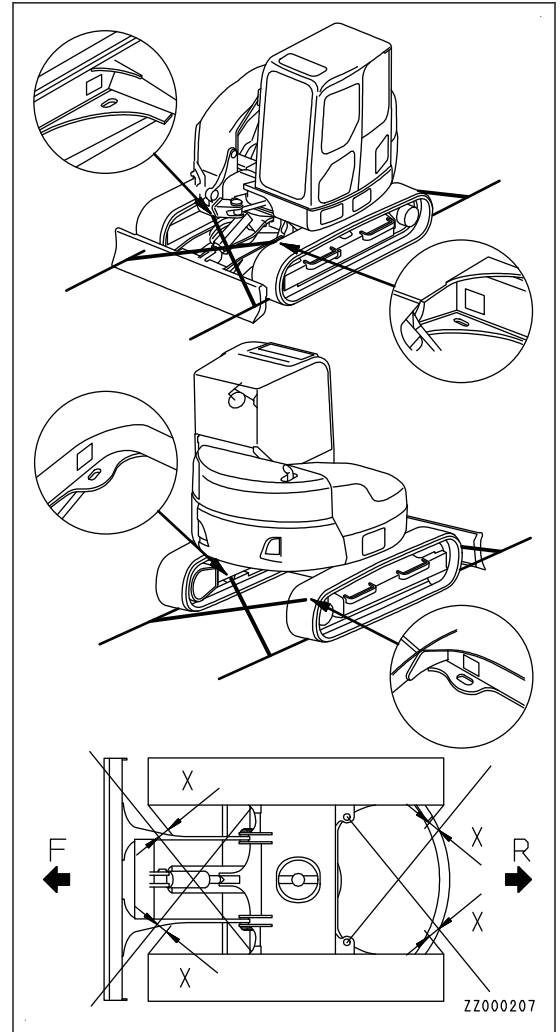

- Securing the machine when not using the tie-down point  
Place blocks under both ends of the tracks to prevent the machine from moving during transportation, and secure the machine with chains or wire ropes of suitable strength.  
At this time, place pieces of wood between the wire ropes and the machine to prevent damage to the ropes and the machine.  
In particular, fix the machine securely to prevent it from slipping sideways.

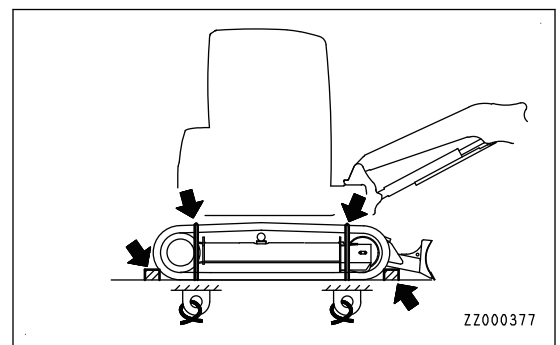

**PROCEDURES FOR UNLOADING MACHINE**

Perform unloading of the machine on a firm, level ground.

Maintain a safe distance from the road shoulder

1. Apply the trailer brakes securely, then put chocks (1) under the tires to prevent the trailer from moving.
2. Set right and left ramps (2) parallel to each other and equally spaced to the right and left of center (3) of the trailer. Make angle of installation (4) a maximum of 15 deg.  
If the ramps bend a large amount under the weight of the machine, put blocks under the ramps to prevent them from bending.
3. Remove the chains and wire ropes fastening the machine.
4. Start the engine.  
Warm the engine up fully in cold weather.
5. Set the lock lever to FREE position (F).

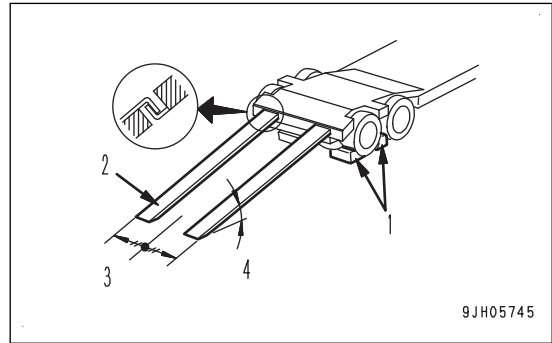

9JH05745

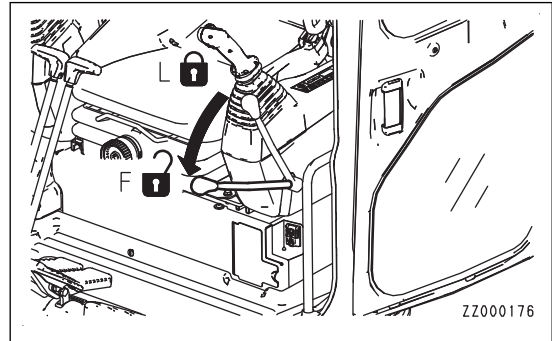

ZZ000176

6. Turn the travel speed selector switch to low-speed travel ("Lo" lamp lights up).  
Press travel speed selector switch (5) to switch the travel speed. The travel speed ("Lo", "Hi") is displayed on travel speed display (6).
7. Turn auto-deceleration switch (7) OFF and operate the fuel control dial to set the engine to low speed.  
Each time auto-deceleration switch (7) is pressed, it switches OFF to ON to OFF in turn.  
When auto-deceleration switch (7) is turned OFF, the auto-deceleration pilot lamp (8) goes out.

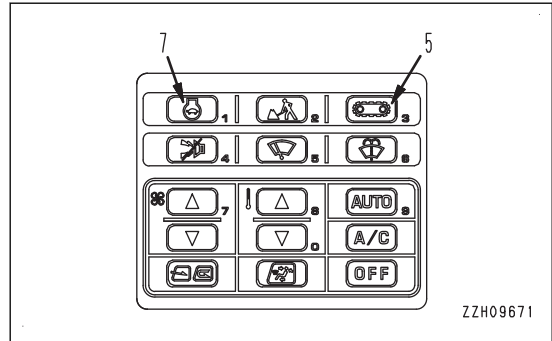

ZZH09671

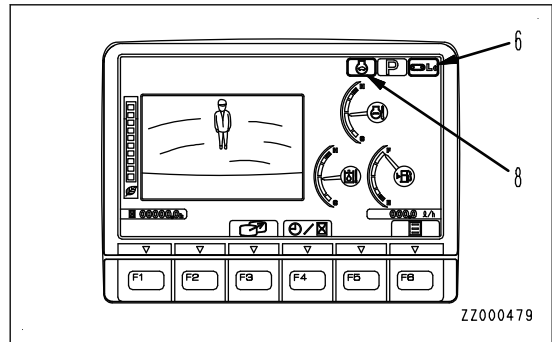

ZZ000479

8. Raise the work equipment, curl the arm under the boom, then move the machine slowly.
9. When the machine is horizontal on the top of the rear end of the trailer, stop the machine.

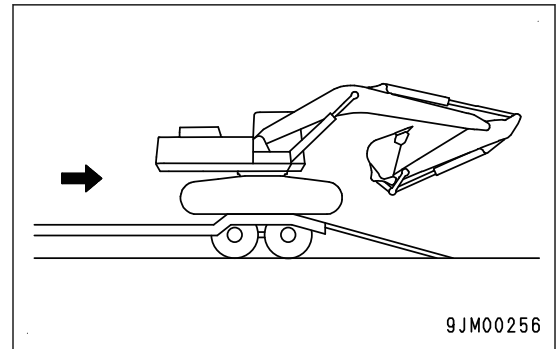

10. Set the angle between the arm and boom to 90 deg. to 110 deg.

**NOTICE**

**When unloading the machine, always set the angle between the arm and boom to 90 deg. to 110 deg.**

**If the machine is unloaded while the arm is IN, it will cause damage to the machine.**

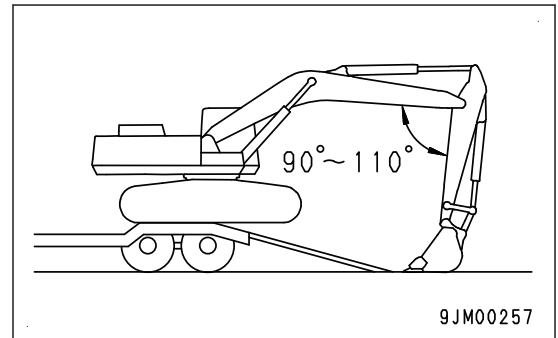

11. Lower the bucket to the ground.

**NOTICE**

**Do not hit the bucket against the ground to prevent damage to the hydraulic cylinders.**

12. With the bucket lowered to the ground, move to the ramps slowly from the rear end of the trailer.
13. Operate the boom and arm slowly to lower the machine carefully until it is completely off the ramps.

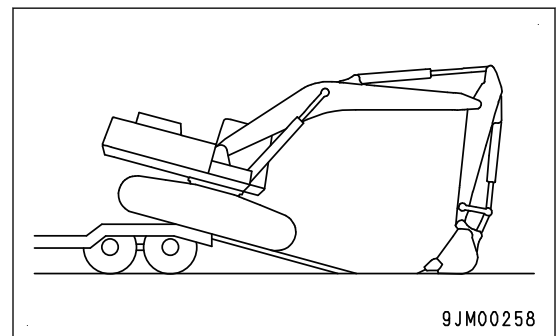

## METHOD FOR LIFTING MACHINE

### WARNING

- The person using the crane to perform lifting operations must be a qualified crane operator.
- Never perform lifting operation if any person is on the machine being lifted.
- Always use a wire rope that has ample strength for the weight of the machine being lifted.
- When lifting, keep the machine horizontal.
- When performing lifting operations, do as follows to prevent the machine from moving unexpectedly.
  - Operate the work equipment lock lever to LOCK position.
  - Set the swing lock cover in LOCK state.
- Never enter the area under or around a lifted machine.

Never try to lift the machine in any posture other than the posture given in the procedure below and using lifting equipment other than the one in the procedure below. There is a danger of the machine losing its balance.

### NOTICE

This method of lifting applies to the standard specification machine.

The method of lifting differs depending on the attachments and options installed.

For details of the procedure for machines that are not the standard specification, consult your Komatsu distributor.

When lifting the machine, perform the operation on flat ground as follows.

1. Start the engine.
2. Swing the upper structure so that the work equipment is on the sprocket (1) side.
 

At this time, set the track frame and upper structure in parallel.
3. Extend the bucket cylinder and arm cylinder fully, then lower the work equipment to the ground using the boom cylinder as shown in the figure.
4. Lower the blade to the ground.
5. Set the lock lever securely to LOCK position (L).
6. Stop the engine.

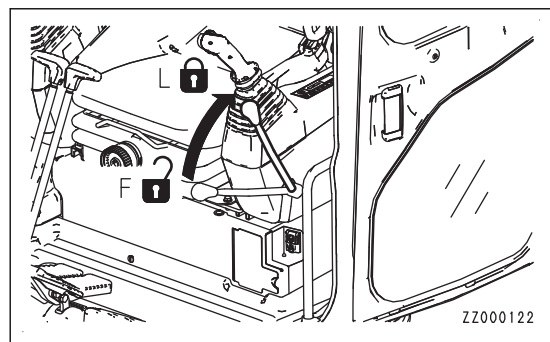
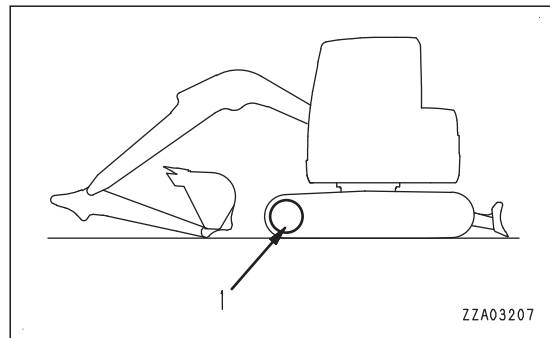

7. Check that there is nothing around the operator's seat, and then get off the machine. Close the cab door and front window securely.

8. Pass wire ropes between the 1st and 2nd track rollers from the front and between the 1st and 2nd track rollers from the rear.

Place pieces of wood between the wire ropes and the machine to prevent damage to the ropes and the machine.

**NOTICE**

**When lifting the machine, do not install the wire ropes to the machine fixing brackets.**

**If the fixing brackets are used to lift the machine, the machine is damaged.**

9. Set the lifting angle (A) of the wire rope to 30 to 40 °, then sling the machine slowly.
10. After the machine comes off the ground, check the hook condition and the lifting posture, and then sling the machine slowly.

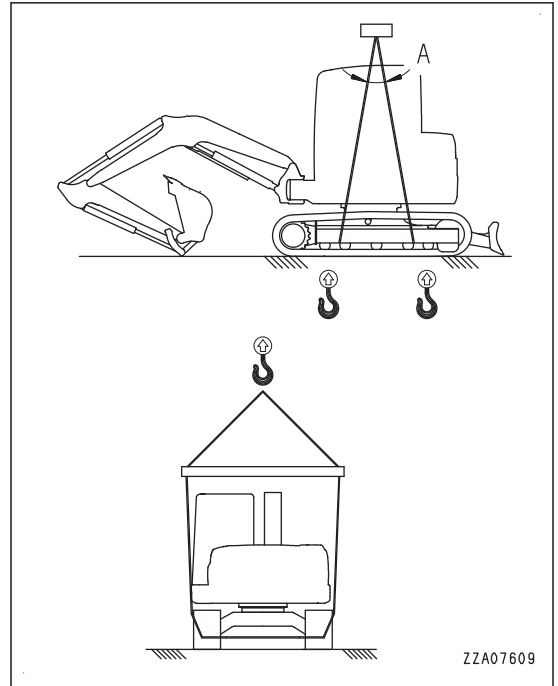

# COLD WEATHER OPERATION

## COLD WEATHER OPERATION INFORMATION

If the temperature becomes low, it becomes difficult to start the engine, and the coolant may freeze, so do as follows.

### FUEL AND LUBRICANTS

Change fuel and oil with ones of low viscosity for all components.

For the details of specified viscosity, see "METHOD FOR USING FUEL, COOLANT AND LUBRICANTS ACCORDING TO AMBIENT TEMPERATURE".

### COOLANT

#### WARNING

- Coolant is toxic. Be careful not to get it into your eyes or on your skin. If it should get into your eyes or on your skin, wash it off with large amount of fresh water and see a doctor immediately.
- When handling the cooling water containing coolant that has been drained during changing the coolant or repair of radiator, contact your Komatsu distributor or request a qualified company to perform the operation. Coolant is toxic, so never pour it into drainage ditches or drain it onto the ground surface.

### NOTICE

**Komatsu recommends using Non-Amine Engine Coolant (AF-NAC) for the coolant.**

Non-Amine Engine Coolant (AF-NAC) is already diluted with distilled water, so it is not flammable.

For details on the coolant change interval and the density of Non-Amine Engine Coolant (AF-NAC), see "METHOD FOR USING FUEL, COOLANT AND LUBRICANTS ACCORDING TO AMBIENT TEMPERATURE".

### BATTERY

#### WARNING

- Do not bring any open flame near the battery. Otherwise, it may explode since the battery generates the flammable gas.
- Battery electrolyte is dangerous object. If it gets in your eyes or on your skin, wash it off with a large amount of water and consult a doctor.
- Battery electrolyte dissolves paint. If it gets on the bodywork, wash it off immediately with water.
- If the battery electrolyte is frozen, do not charge the battery or start the engine with a different power source. There is danger that the battery may explode.
- Battery electrolyte is toxic. Do not let it flow into drainage ditches or spray it on to the ground surface.

When the ambient temperature drops, the capacity of the battery will also drop. If the battery charging rate is low, the battery electrolyte may freeze. Maintain the battery charging rate as close as possible to 100 %. Insulate it against cold temperature to ensure the machine can be started easily the next morning.

### REMARK

Measure the gravity of the electrolyte and calculate the charging rate from the following conversion table.

Electrolyte temperature Charging rate (%)	20 °C {68 °F}	0 °C {32 °F}	-10 °C {14 °F}	-20 °C {-4 °F}
100	1.28	1.29	1.30	1.31
90	1.26	1.27	1.28	1.29
80	1.24	1.25	1.26	1.27
75	1.23	1.24	1.25	1.26

- As the battery capacity drastically drops in low temperatures, cover or remove the battery from the machine, store the battery in a warm place, and install it again the next morning.
- If the electrolyte level is low, add distilled water in the morning before beginning work. Do not add water after the day's work to prevent diluted electrolyte in the battery from freezing during the night.

## PRECAUTIONS AFTER DAILY WORK COMPLETION IN COLD WEATHER

### WARNING

**Performing idling of the tracks is dangerous, stay well away from the tracks.**

To prevent mud, water, or the undercarriage from freezing and making it impossible for the machine to move on the following morning, observe the following precautions.

- Remove all the mud and water from the machine body. In particular, wipe the hydraulic cylinder rods clean to prevent damage to the seal caused by mud, dirt, or drops of water on the rod from getting inside the seal.
- Place the machine on a firm, dry ground.  
If this is impossible, park the machine on boards.  
The boards prevent the tracks from freezing to the ground, and allow the machine to move the next morning.
- Open the drain valve and drain any water collected in the fuel system to prevent it from freezing.
- Fill up the fuel tank. This minimizes moisture condensation in the tank when the temperature drops.
- After operation in water or mud, remove water from undercarriage according to the procedure to extend undercarriage service life.
  1. Run the engine at low idle and swing the upper structure 90 ° to bring the work equipment to the side of the track.
  2. Set the machine in the posture shown in the figure.
    - 1) Operate the work equipment control levers, and lower the bucket bottom to the ground.
    - 2) Operate the work equipment control levers slowly, and push the ground with the bucket bottom to raise the track slightly.
  3. Operate the travel lever and perform idle rotation of the track.
  4. Repeat performing steps 1 to 3 for both of the right and left.

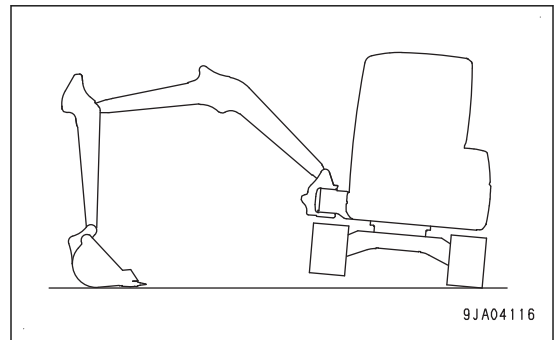

## AFTER COLD WEATHER SEASON

When the season changes and the weather becomes warmer, do as follows.

Replace the fuel and oil for all equipment with the ones of the specified viscosity. For details, see "METHOD FOR USING FUEL, COOLANT AND LUBRICANTS ACCORDING TO AMBIENT TEMPERATURE".



# PRECAUTIONS FOR LONG-TERM STORAGE

## PREPARATION FOR LONG-TERM STORAGE

### NOTICE

When storing the machine (1 month or more), set the machine in the posture shown in the figure to protect the cylinder rods.

(To prevent the cylinder piston rods from rusting)

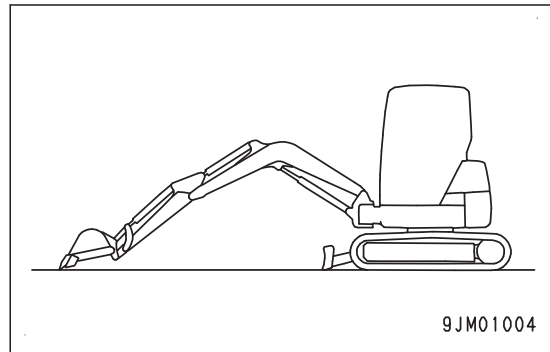

When putting the machine in storage for a long time (more than 1 month), do as follows.

- Clean and wash all parts of the machine and store it indoors. If the machine has to be stored outdoors, select a level ground and cover the machine with waterproof sheet, etc.
- Fill up the fuel tank. This prevents dew condensation.
- Grease the machine and change the oil before storage.
- Coat the exposed portion of the hydraulic cylinder piston rod with grease.
- Turn the starting switch to OFF position and turn the battery disconnect switch key to OFF position, and remove it. When storing the battery, cover it.
- Lock each control lever and pedal with the lock lever and lock cover.
- If the machine is ready for installation of attachment, set the selector valve to the “General attachments such as crusher” position.
- To prevent rust, fill the cooling circuit with Non-Amine Engine Coolant (AF-NAC) to give a density of at least 30 % for the engine coolant.

## MAINTENANCE DURING LONG-TERM STORAGE

### WARNING

**If it is necessary to perform the rust-prevention operation while the machine is indoors, open the doors and windows to improve ventilation and prevent gas poisoning.**

- During storage, operate and move the machine for a short distance once a month so that a new film of oil will coat moving parts. At the same time, charge the battery as well.
- When operating the work equipment, wipe off all the grease from the hydraulic cylinder rods.
- If the machine is equipped with an air conditioner, operate the air conditioner for 3 to 5 minutes once a month to lubricate all parts of the air conditioner compressor. Always run the engine at low idle when doing this. In addition, check the refrigerant level twice a year.

## STARTING MACHINE AFTER LONG-TERM STORAGE

### NOTICE

**If the machine has been stored without performing the monthly rust-prevention operation, consult your Komatsu distributor before using it.**

When using the machine after long-term storage, perform the following items before using it.

- Wipe off the grease from the hydraulic cylinder rods.
- Add oil and grease at all lubrication points.
- When the machine is stored for a long period, moisture in the air will mix with the oil. Check the oil before and after starting the engine. If there is water in the oil, change all the oil.
- Insert the battery disconnect switch key and turn it to ON position.
- If the machine is stored for a long period with the battery disconnect switch OFF or the battery terminal disconnected, the clock information and radio tuning information may be lost. In this case, set the information again. For detail, see "CLOCK ADJUSTMENT", "HANDLE RADIO".
- When starting the engine, warm it up sufficiently.

## TROUBLES AND ACTIONS

### ACTIONS WHEN RUNNING OUT OF FUEL

When starting the engine again after running out of fuel, fill with fuel, and bleed the air from the fuel system before starting the engine.

Always check the fuel level to prevent running out of fuel.

If the engine has stopped due to run out of fuel, all air must be sufficiently bled from the fuel circuit.

### PROCEDURES FOR BLEEDING AIR FROM FUEL CIRCUIT

1. Turn the starting switch key to OFF position (A) and stop the engine.

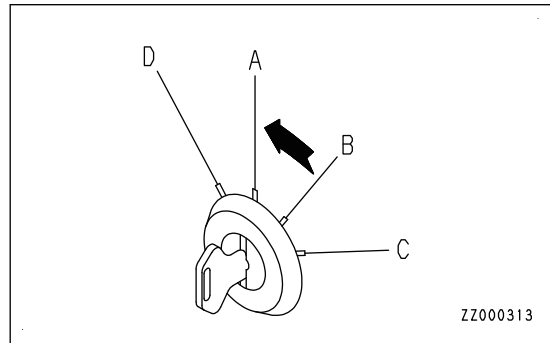

2. Loosen the knob of feed pump (1), pull it out, then pump it in and out until the movement becomes heavy.

#### REMARK

It is not necessary to remove the plugs at the fuel prefilter head and at the fuel main filter head.

3. Push in and tighten the knob of feed pump (1).
4. Turn the starting switch key to START position and start the engine.

Do not operate the starting motor continuously for more than 20 seconds. If the engine does not start, wait for at least 2 minutes before trying again. Perform this operation a maximum of 4 times.

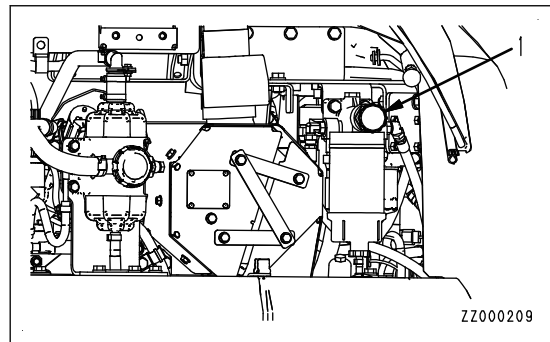

## PHENOMENA THAT ARE NOT FAILURES

Note that the following phenomena are not failures:

- When the arm is operated IN from a high position for digging under no load, the arm speed drops momentarily at the vertical position.
- When performing bucket CURL operation from a high position for digging under no load, the bucket speed drops momentarily at the horizontal position.
- The bucket or arm wobbles by itself during heavy-duty digging operations.
- When starting or stopping the swing, a noise is generated from the brake valve.
- When going down a steep slope at low speed, a noise is generated from the travel motor brake valve.

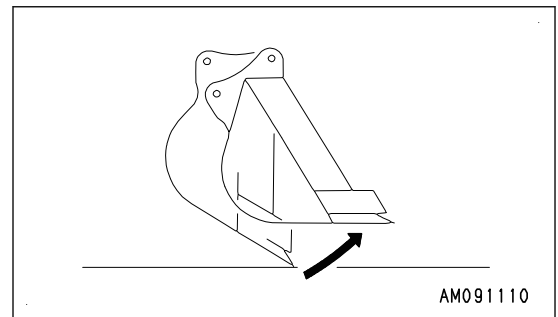
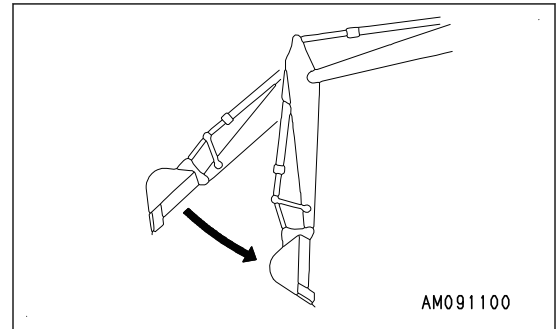

## PRECAUTIONS FOR TOWING MACHINE

### ⚠ WARNING

Always use the correct towing equipment and towing method. Any mistake in the selection of the wire rope or drawbar or the method of towing a disabled machine and being towed may lead to serious personal injury or death.

- Always confirm that the wire rope or drawbar used for towing has ample strength for the weight of the machine being towed.
- Never use a wire rope which has breaks in strands (A), reduced diameter (B), or kinks (C). There is a danger that the rope may break during the towing operation.
- Always wear leather gloves when handling the wire rope.
- Never tow a machine on a slope.
- During the towing operation, never stand between the towing machine and the machine being towed.
- Operate the machine slowly and be careful not to apply any sudden load to the wire rope.
- Do not use the holes for towing light objects or tie-down holes when towing the machine.

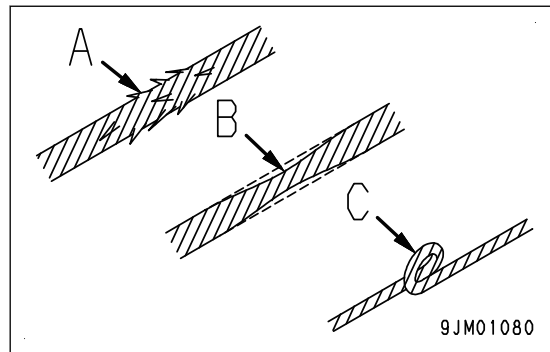

### NOTICE

The maximum towing capacity for this machine is 50,400 N {5,140 kg} .

Do not tow any load greater than this.

- If the machine sinks in mud and cannot get out under its own power, or if the machine tows a heavy object, use a wire rope as shown in the figure.
- Place pieces of wood between the wire ropes and the machine to prevent damage to the ropes and the machine.
- Hold the wire rope level and set it straight to the track frame.
- When towing a machine, travel at a speed of less than 1 km/h {0.6 MPH} for a distance of only a few meters to a place that is suitable for performing repairs.

This method is applied only in emergencies.

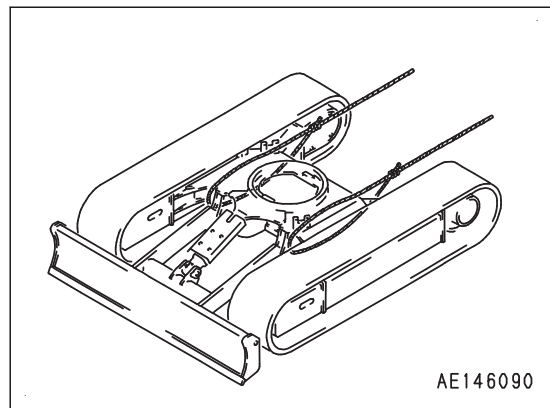

## PRECAUTIONS FOR SEVERE JOB CONDITION

- When performing digging operations in water, if the work equipment mounting pin goes into the water, perform greasing every time the operation is performed.
- For heavy-duty operations and deep digging, perform greasing of the work equipment mounting pins every time before operation.  
After greasing, operate the boom, arm and bucket several times, then grease again.

## PRECAUTIONS FOR DISCHARGED BATTERY

### WARNING

- It is dangerous to charge a battery when installed on a machine. Make sure that it is removed before charging.
- When checking or handling the battery, stop the engine and turn the starting switch and battery disconnect switch keys to OFF positions.
- The battery generates hydrogen gas, and it is dangerous that it may explode. Do not bring lighted cigarettes near the battery, or do nothing that will cause sparks.
- Battery electrolyte is dilute sulfuric acid, and it will attack your clothes and skin. If it gets on your clothes or on your skin, immediately wash it off with a large amount of clean water.  
If it gets in your eyes, wash the eyes immediately with clean water, then consult a doctor for medical treatment.
- When handling batteries, always wear protective eyeglasses and rubber gloves.
- When removing the battery, first disconnect the cable from the ground (normally the negative (-) terminal). When installing, first connect the cable to the positive (+) terminal.  
If a tool touches the positive terminal and the chassis, it is dangerous that it may cause a spark. Be extremely careful.
- If the terminals are loose, it is dangerous that the defective contact may generate sparks, and it may cause an explosion.  
Install the cable terminals securely.
- When removing or installing the cable terminals, check which is the positive (+) terminal and which is the negative (-) terminal.

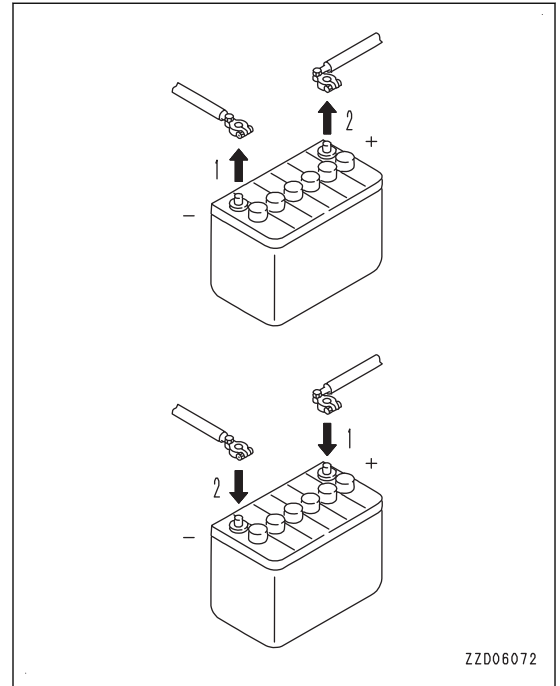

**METHOD FOR REMOVING AND INSTALLING BATTERY****⚠ WARNING**

When handling the battery, stop the engine and turn the starting switch and battery disconnect switch keys to OFF positions.

**METHOD FOR REMOVING BATTERY**

1. Open engine hood (1).
2. Lock the engine hood securely with the hood support lever.
3. Open battery inspection cover (2).
4. Lock the battery inspection cover securely with the cover support lever.
5. Remove wing nuts (3) (2 places).
6. Remove rubber cover (4).
7. Remove cable (5) on the negative (-) terminal side (ground side) first.
8. Remove cable (6) on the positive (+) terminal side and connecting cable (7).
9. Remove mounting bolts (8) (4 places).
10. Remove mounting hardware (9).
11. Take the battery out of the machine.

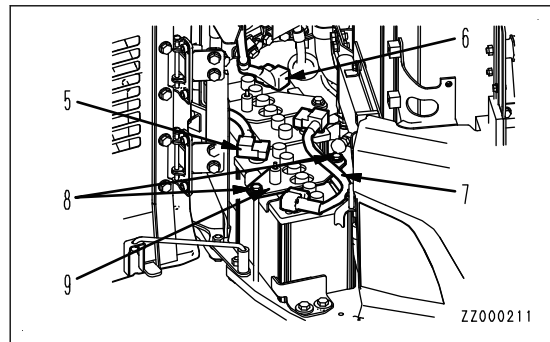
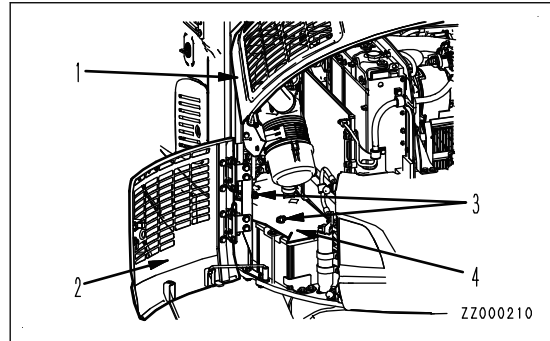

## METHOD FOR INSTALLING BATTERY

### NOTICE

**After securing the battery, check that it does not move.**

**If it moves, tighten it again securely.**

1. Place the battery in the specified position.
2. Fix the battery firmly by using mounting hardware (9) and mounting bolts (8).  
Allowable tightening torque of mounting bolt: 9.8 to 19.6 Nm {1 to 2 kgm, 7.2 to 14.5 lbft}
3. Install cable (6) on the positive (+) terminal side.
4. Connect connecting cable (7) to the positive (+) terminal side first.
5. Connect cable (5) on the negative (-) terminal side (ground side).
6. Install rubber cover (4) with wing nuts (3).

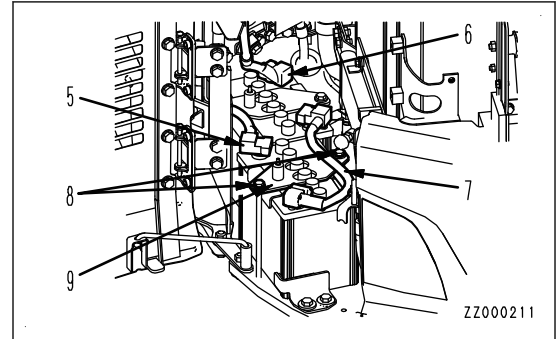

### NOTICE

- For prevention of a fire, install rubber cover (4) carefully so that it will not roll up.
- If rubber cover (4) rolls up and blocks the fuel cooler, the fuel may overheat. Take care to insert rubber cover (4) under fuel cooler (10).

7. Insert rubber cover (4) under fuel cooler (10).
8. Remove the cover support lever from the hole of the bottom cover and insert it into the mounting hole of battery inspection cover (2).
9. Close battery inspection cover (2).
10. Remove the hood support lever and securely fix it to the lever lock.
11. Close engine hood (1).

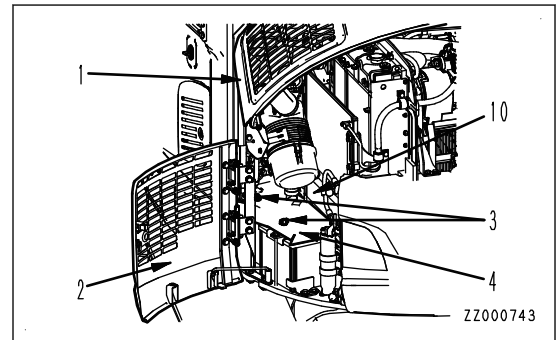



## PRECAUTIONS FOR CHARGING BATTERY

### **WARNING**

When charging the battery, if the battery is not handled correctly, there is a danger that the battery may explode. Follow the instruction manual accompanying the battery charger, and observe the following.

- Set the voltage of the charger to match the voltage of the battery to be charged. If the correct voltage is not selected, the charger may overheat and cause an explosion.
- Connect the positive (+) charger clip of the charger to the positive (+) terminal of the battery, then connect the negative (-) charger clip of the charger to the negative (-) terminal of the battery. Be sure to attach the clips securely.
- Set the charging current to 1/10 of the value of the rated battery capacity; when performing rapid charging, set it to less than the rated battery capacity.  
If the charger current is too high, the electrolyte will leak or the battery cells will dry up, and this may cause the battery to catch fire and explode.
- If the battery electrolyte is frozen, do not charge the battery or start the engine with a different power source. It is dangerous that this may ignite the battery electrolyte and cause the battery to explode.
- Do not use or charge the battery if the battery electrolyte level is below LOWER LEVEL line. This may cause an explosion. Check the battery electrolyte level periodically and add distilled water to bring the electrolyte level to UPPER LEVEL line.

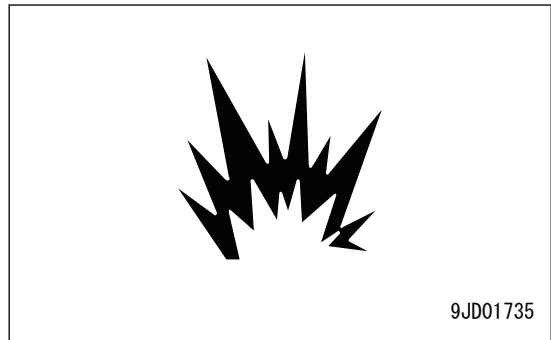

## START ENGINE WITH JUMPER CABLES

### **⚠ WARNING**

- When connecting the cables, never contact the positive (+) and negative (-) terminals.
- Always wear protective eyeglasses and rubber gloves when starting the engine by using the jumper cable.
- Be careful not to let the normal machine and failed machine contact each other.  
The sparks caused near the battery could ignite the hydrogen gas generated from the battery, so be careful not to let it happen.
- Make sure that there is no mistake in the jumper cable connections. In the last connection (to the upper structure frame), a spark will be caused, connect the cable to a spot as far away from the battery as possible. (However, do not connect to the work equipment since the current does not flow well through it.)
- When removing the booster cable, exercise good care so that the booster cable clips may not contact each other, or they contact the chassis.

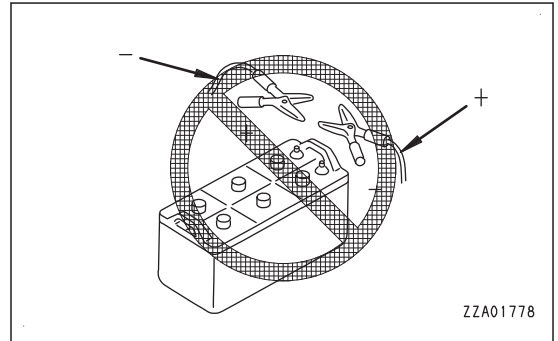

### NOTICE

- The starting system for this machine uses 24 V. Accordingly, the normal machine must be equipped with a 24 V battery.
- The sizes of the jumper cables and clips should be suitable for the battery size.
- The battery of the normal machine must be the same capacity as that of the failed machine.
- Check the cables and clips for damage or corrosion.
- Make sure that the cables and clips are firmly connected.
- Check that the lock levers and parking brake levers (if equipped) of both machine are in LOCK position.
- Check that each lever is in NEUTRAL position.
- To prevent damage of the electric devices of the failed machine, turn the starting switch of the failed machine to OFF position, and then turn the battery disconnect switch key to OFF position before connecting the jumper cables.

### Connect booster cable

Turn the starting switch and battery disconnect switch of the failed machine, and the starting switch of the normal machine to OFF position.

1. Connect the clip of booster cable (A) to the positive (+) terminal of battery (C) on the failed machine.
2. Connect the clip at the other end of booster cable (A) to the positive (+) terminal of battery (D) on the normal machine.
3. Connect the clip of booster cable (B) to the negative (-) terminal of battery (D) on the normal machine.
4. Turn the battery disconnect switch (S) of the failed machine to ON position.
5. Connect the other clip of booster cable (B) to the revolving frame (E) of the failed machine.

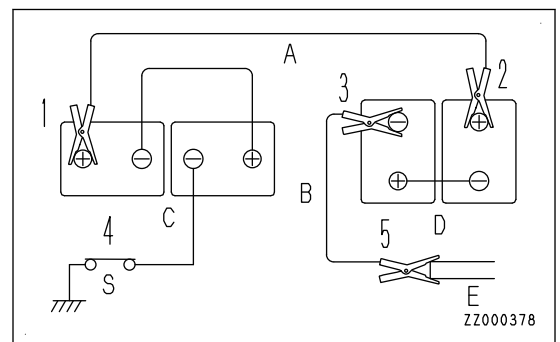

## Start engine

### WARNING

Check both of normal machine and failed machine that the lock lever is set to LOCK position. Check also that all the control levers are in NEUTRAL position.

1. Make sure the clips are firmly connected to the battery terminals.
  2. Start the engine of the normal machine and run it at high idle (max. speed).
  3. Turn the starting switch of the failed machine to the START position to start the engine.
- If the engine does not start at first, try again after 2 minutes or more.

### Remove booster cable

After the engine has started, disconnect the booster cables in the reverse of the order in which they were connected.

1. Remove the clip of booster cable (B) from the revolving frame (E) of the failed machine.
2. Remove the clip of booster cable (B) from the negative (-) terminal of battery (D) on the normal machine.
3. Remove the clip of booster cable (A) from the positive (+) terminal of battery (D) on the normal machine.
4. Remove the clip of booster cable (A) from the positive (+) terminal of battery (C) on the failed machine.

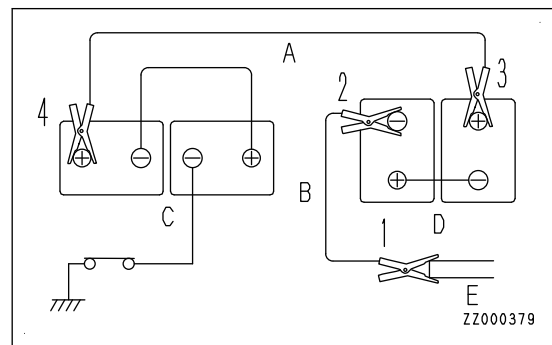

## OTHER TROUBLE

### PHENOMENA AND ACTIONS FOR ELECTRICAL SYSTEM

- For the remedies indicated with (\*) in the remedy column, always contact your Komatsu distributor.
- In cases of problems or causes which are not listed below, ask your Komatsu distributor for repairs.

Problem	Main causes	Remedy
Lamp does not glow brightly even when the engine runs at high speeds.	Defective wiring, deterioration of battery	Check and repair loose terminal or wire breakage, replace battery. (*)
	Loosening and damage of fan belt	Check fan belt tension and replace. (*)
Lamp flickers while engine is running.	Defective wiring, deterioration of battery	Check and repair loose terminal or wire breakage, replace battery. (*)
	Loosening and damage of fan belt	Check fan belt tension and replace. (*)
Charge level caution lamp does not go out even when engine is running.	Defective alternator	Replace. (*)
	Defective wiring	Check, repair. (*)
	Loose fan belt	Check fan belt tension and replace. (*)
Unusual noise is generated from alternator.	Defective alternator	Replace. (*)
Starting motor does not rotate even when starting switch is turned to START position.	Defective wiring	Check, repair. (*)
	Defective starting motor	Replace. (*)
	Insufficient battery charge	Charge battery.
	Battery disconnect switch at OFF position	Turn ON.
	Engine shutdown secondary switch at "engine stop" position	Set it to "Normal" position and install a cover to it.
Pinion of starting motor repeats engaging and disengaging (rattles).	Insufficient battery charge	Charge battery.
	Defective safety relay	Replace. (*)
Starting motor turns engine sluggishly.	Insufficient battery charge	Charge battery.
	Defective starting motor	Replace. (*)
Starting motor disengages before engine starts.	Defective wiring, defective ring gear and pinion	Check, repair. (*)
	Insufficient battery charge	Charge battery.
Preheating pilot lamp does not light up.	Defective wiring	Check, repair. (*)
	Defective heater relay	Replace. (*)
	Defective monitor	Replace. (*)
Oil pressure caution lamp does not light up when engine is stopped (starting switch is at ON position).	Defective monitor	Replace. (*)
	Defective caution lamp switch	Replace. (*)
When startability at low temperature is poor, if you touch the outside of the electric heater by hand after preheating, it is not felt warm.	Defective wiring	Check, repair. (*)
	Wire breakage in electrical intake air heater	Replace. (*)
	Defective operation of heater relay	Replace. (*)
	Blown fuse of heater	Replace. (*)

Problem	Main causes	Remedy
Engine does not start. (L04 lights up on monitor.)	Damaged data in the controller	Check, repair. (*)
	Other system troubles	Check, repair. (*)
When travel lever is operated, travel alarm does not sound.	Defective wiring	Check and repair loose connector terminal or wire breakage. (*)
	Defective alarm	Replace. (*)
	Defective PPC pressure sensor	Replace. (*)
Rearview monitor displays nothing. (Machine with rearview camera)	Defective wiring	Check and repair loose or disconnected connector or wire breakage. (*)
	Defective camera	Replace. (*)
	Defective monitor	Replace. (*)
The engine does not start even if the key in the starting switch is turned to START position and the starting motor rotates.	Defective engine controller power supply circuit	Replace. (*)
	Defective relay	Replace. (*)
	Defective connector on engine side	Check and repair loose or disconnected connector or wire breakage. (*)

**PHENOMENA AND ACTIONS FOR CHASSIS**

- For the remedies indicated with (\*) in the remedy column, always contact your Komatsu distributor.
- In cases of problems or causes which are not listed below, ask your Komatsu distributor for repairs.

Problem	Main causes	Remedy
Speed of travel, swing, boom, arm, bucket is slow	Lack of hydraulic oil	Set oil to specified level. See CHECKS BEFORE STARTING.
Pump generates abnormal noise. (sucking in air)	Clogged element in hydraulic tank strainer, lack of oil	Clean. See EVERY 2000 HOURS MAINTENANCE.
Excessive rise in hydraulic oil temperature	Loose fan belt	Check fan belt tension and replace. (*)
	Dirty oil cooler	Clean. See EVERY 500 HOURS MAINTENANCE.
	Lack of hydraulic oil	Set oil to specified level. See CHECKS BEFORE STARTING.
Track comes off.	Track too loose	Adjust track tension, see WHEN REQUIRED.
Abnormal wear of sprocket	Track too loose	Adjust track tension, see WHEN REQUIRED.
Boom rises slowly or does not rise.	Lack of hydraulic oil	Set oil to specified level. See CHECKS BEFORE STARTING.

## PHENOMENA AND ACTIONS FOR ENGINE RELATED PARTS

- For the remedies indicated with (\*) in the remedy column, always contact your Komatsu distributor.
- In cases of problems or causes which are not listed below, ask your Komatsu distributor for repairs.

Problem	Main causes	Remedy
Engine oil pressure caution lamp lights up.	Lowered oil level in engine oil pan (sucking in air)	Set oil to specified level. See CHECKS BEFORE STARTING.
	Improper oil is used. (Viscosity is improper.)	Replace oil. See METHOD FOR USING FUEL, COOLANT AND LUBRICANTS ACCORDING TO AMBIENT TEMPERATURE and KOMATSU GENUINE LUBRICANTS.
	Clogged oil filter cartridge	Replace cartridge. See EVERY 500 HOURS MAINTENANCE.
	Oil leakage due to improper connection or breakage of oil pipe or pipe joint	Check, repair. (*)
	Defective engine oil pressure sensor	Replace sensor. (*)
	Defective monitor	Replace monitor. (*)
Steam spurts out from top of radiator (pressure valve).	Lowered coolant level, leakage of coolant	Check, add coolant, repair. See CHECKS BEFORE STARTING.
	Loose fan belt	Check fan belt tension, replace. (*)
	Dirt or scale accumulated in cooling system	Change coolant, flush inside of cooling system. See WHEN REQUIRED.
	Clogged radiator fins or damaged fin	Clean or repair. See EVERY 500 HOURS MAINTENANCE.
	Defective thermostat	Replace thermostat. (*)
	Loosened radiator filler cap (in high altitude operation)	Tighten cap or replace packing.
	Defective monitor	Replace monitor. (*)
Indicator of engine coolant temperature gauge is in red range.	Lowered coolant level, leakage of coolant	Check, add coolant, repair. See CHECKS BEFORE STARTING.
	Loose fan belt	Check fan belt tension, replace. (*)
	Dirt or scale accumulated in cooling system	Change coolant, flush inside of cooling system. See WHEN REQUIRED.
	Clogged radiator fins or damaged fin	Clean or repair. See EVERY 500 HOURS MAINTENANCE.
	Defective thermostat	Replace thermostat. (*)
	Loosened radiator filler cap (in high altitude operation)	Tighten cap or replace packing.
	Defective monitor	Replace monitor. (*)

Problem	Main causes	Remedy
Starting motor rotates but engine does not start.	Lack of fuel	Add fuel. See CHECKS BEFORE STARTING.
	Air in fuel system	Repair place where air is sucked in. See EVERY 500 HOURS MAINTENANCE.
	Defective fuel injection pump or defective nozzle	Replace pump or nozzle. (*)
	Starting motor turns engine sluggishly.	See PHENOMENA AND ACTIONS FOR ELECTRICAL SYSTEM.
	Preheating pilot lamp does not light up.	See PHENOMENA AND ACTIONS FOR ELECTRICAL SYSTEM.
	Defective compression (Defective valve clearance)	Adjust valve clearance. (*)
Exhaust gas color is white or bluish.	Excessive oil in oil pan	Set oil to specified level. See CHECKS BEFORE STARTING.
	Improper fuel	Replace with specified fuel.
Exhaust gas turns black from time to time.	Clogged air cleaner element	Clean or replace. See WHEN REQUIRED.
	Defective nozzle	Replace nozzle. (*)
	Defective compression	See the above section on defective compression. (*)
	Defective turbocharger	Clean or replace turbocharger. (*)
Combustion makes breathing sound from time to time.	Defective nozzle	Replace nozzle. (*)
Abnormal noise is generated. (combustion or mechanical)	Low grade fuel being used	Replace with specified fuel.
	Overheating	See the above section on "Indicator of engine coolant temperature gauge is in red range".
	Damage inside muffler	Replace muffler. (*)
	Excessive valve clearance	Adjust valve clearance. (*)
Engine stalls during operation.	Clogging of pre-filter or main filter	Replace filter cartridge.
	Defective engine and fuel circuit	Check, repair. (*)



### IF MACHINE MONITOR SHOWS WARNING DISPLAY

When the action level display (1) or caution lamp (2) is shown on the display of the machine monitor, press switch F5 to display "Current Abnormality" and check the details and remedy.

Take the actions according to the message shown on the machine monitor, and check the failure code, and then ask your Komatsu distributor for repair, as necessary.

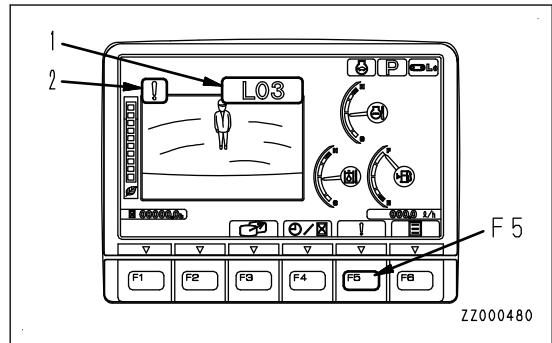

- When "DXA8KA" or "DXA8KB" is on "Current Abnormality" screen, you can make it possible to perform operations temporarily by turning the pump secondary drive switch to upper (emergency) position. For details of the pump secondary drive switch, see "PUMP SECONDARY DRIVE SWITCH".

After that, immediately ask your Komatsu distributor for inspection and repair.

- When the machine has not run out of fuel, if "CA2249" or "CA559" appears on "Current Abnormality" screen, replace both fuel main filter and fuel prefilter immediately.

If "CA2249" or "CA559" does not disappear even after the replacement, ask your Komatsu distributor for inspection immediately, even though the machine can perform normal operation.

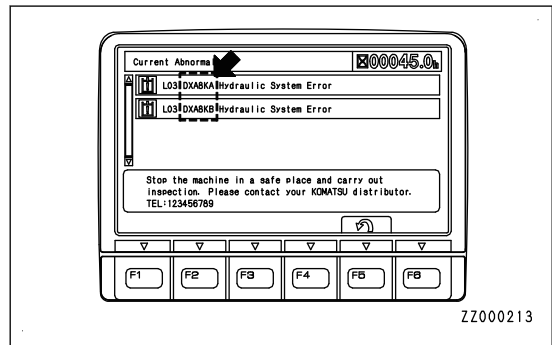

### Telephone number for the point of contact if an error occurs

When an error screen is displayed on the monitor, press the switch F5 to display "Current Abnormality" screen and telephone number (3) for the point of contact is displayed in the message column at the bottom of the screen.

#### REMARK

If no point of contact telephone number is registered, no telephone number is displayed. Ask your Komatsu distributor for the telephone number registration if necessary.

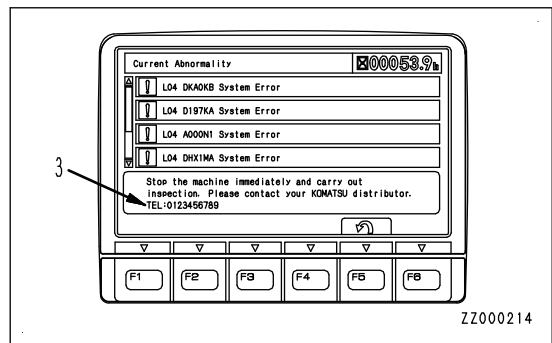

# MAINTENANCE

## **WARNING**

Please read and make sure that you understand the SAFETY section before reading this section.

---

## PRECAUTIONS FOR MAINTENANCE

Do not perform any inspection and maintenance operation that are not found in this manual.

### CHECK SERVICE METER READING

Check the service meter reading every day to see if the maintenance time has come for any necessary maintenance item to be performed.

### KOMATSU GENUINE REPLACEMENT PARTS

Komatsu recommends using Komatsu genuine parts specified in Parts Book as replacement parts.

### KOMATSU GENUINE LUBRICANTS

For lubrication of the machine, Komatsu recommends using Komatsu genuine lubricants. Moreover use oil of the specified viscosity according to the ambient temperature.

### ALWAYS USE CLEAN WASHER FLUID

Use automobile window washer fluid, and be careful not to let any dirt get into it.

### FRESH AND CLEAN LUBRICANTS

Use clean oil and grease. Also, keep the containers of the oil and grease clean. Keep foreign materials away from oil and grease.

### CHECK DRAINED OIL AND USED FILTER

At the replacement of the filters when oil is changed, check the old oil and filters for metal particles and foreign materials. If large quantity of metal particles or foreign materials are found, always report to the person in charge, and perform suitable action.

### PRECAUTIONS FOR REFILLING OIL OR FUEL

If your machine is equipped with a strainer, do not remove it while filling oil or fuel.

### PRECAUTIONS FOR WELDING

- When conducting weld repair, turn the starting switch to OFF position and, after confirming that the system operating lamp is turned off, set the battery disconnect switch key to OFF position and pull it out.
- Do not apply a voltage higher than 200 V continuously.
- Connect grounding cable within 1 m {3 ft 3 in} of the area to be welded. If grounding cable is connected near instruments, connectors, etc., the instruments may malfunction.
- Prevent seals, bearings or bushings from entering the space between the weld zone and grounding point. Seals and the like can cause damage to the nearby parts by catching fire from sparks.
- Do not use the area around the work equipment pins or the hydraulic cylinders as the grounding point. Sparks generated there can damage the plated portion.

### DO NOT DROP THINGS INSIDE MACHINE

- When opening the inspection windows or the oil filler port of the tank to perform inspection, be careful not to drop nuts, bolts, or tools inside the machine.  
If such things are dropped inside the machine, it may cause damage and/or malfunction of the machine, and will lead to failure. If anything drops, be sure to take it out.
- Do not put unnecessary things in your pockets. Carry only things which are necessary for inspection.

## DUSTY JOBSITES

When working at dusty jobsites, observe the following.

- Inspect the dust indicator frequently to see if the air cleaner is dirty or clogged.
- Clean the radiator core frequently to avoid clogging.
- Clean and replace the fuel filter frequently.
- Clean electrical components, especially the starting motor and alternator, to avoid accumulation of dust.
- When checking and replacing the oil or filters, move the machine to a place where there is no dust and take care to prevent dust from entering the system.

## AVOID MIXING OIL

Never mix different brand or grade of oil. If a different brand or grade of oil has to be added, drain the old oil and replace all the oil with the new brand or grade of oil.

## LOCK INSPECTION COVERS

Lock inspection cover securely into position with the lock bar, etc. If inspection or maintenance is performed with inspection cover not locked in position, there is a danger that it may be suddenly shut by the wind and cause personal injury.

## BLEED AIR FROM HYDRAULIC CIRCUIT

When hydraulic equipment is repaired or replaced, or the hydraulic piping is disconnected, the air must be bled from the circuit.

## PRECAUTIONS WHEN INSTALLING HYDRAULIC HOSES

- When removing parts at locations where there are O-rings or gasket seals, clean the mounting surface, and replace them with new parts.  
When doing this, be careful not to forget to assemble O-rings and gaskets.
- When installing the hoses, do not twist them or bend them sharply.  
If they are installed so, their service life will be extremely shortened and they may be damaged.

## CHECKS AFTER INSPECTION AND MAINTENANCE

If you forget to perform the inspection and maintenance, unexpected problems may occur, and this may lead to personal injury. Always observe the following.

### Checks after operation (with engine stopped)

- Have any inspection and maintenance points been forgotten?
- Have all inspection and maintenance items been performed correctly?
- Have any tools or parts been dropped inside the machine? It is particularly dangerous if parts are dropped inside the machine and get caught in the lever linkage mechanism.
- Are there any leakage of coolant or oil? Have all nuts and bolts been tightened?

### Checks while the engine is running

- To perform inspection while the engine is running, one worker must always sit on the operator's seat and be ready to stop the engine at any time. All workers must maintain contact with the other workers.
- Increase the engine speed to check for the leakage of fuel or oil.
- Check if the inspected and serviced area is normally operated.

## FUEL AND LUBRICANTS TO MATCH THE AMBIENT TEMPERATURE

It is necessary to select fuel or lubricant according to the ambient temperature.

# OUTLINE OF MAINTENANCE

- Komatsu recommends using Komatsu genuine parts for replacement parts, grease or oil.
- When changing the oil or adding oil, do not mix different types of oil. When changing the type of oil, drain all the old oil and fill completely with the new oil. Always replace the filter at the same time. (There is no problem if the small amount of oil remaining in the piping mixes with the new oil.)
- Unless otherwise specified, when the machine is shipped from the plant, it is filled with the oil and coolant listed in the table below.

Item	Type
Engine oil pan	Engine oil EO15W40DH (Komatsu genuine)
Damper case	Power train oil TO30 (Komatsu genuine)
Swing machinery case	
Final drive case	
Hydraulic oil system	Power train oil TO10 (Komatsu genuine)
Radiator	Non-Amine Engine Coolant (AF-NAC) (Komatsu genuine) (density: 30% or above)

## HANDLE OIL, FUEL, COOLANT, AND PERFORMING OIL CLINIC

### OIL

- Oil is used in the engine and hydraulic equipment under extremely severe conditions (high temperature, high pressure), and deteriorates with use.  
Always use oil that matches the grade and maximum and minimum ambient temperatures recommended in Operation and Maintenance Manual.  
Even if the oil is not dirty, always change the oil at the specified interval.
- Oil corresponds to blood in the human body, always be careful when handling it to prevent any impurities (water, metal particles, dirt, etc.) from getting in.  
The majority of failures with the machine are caused by the entry of such impurities.  
Take particular care not to let any impurities get in when storing or adding oil.
- Never mix oils of different grades or brands.
- Always add the specified amount of oil.  
Having too much oil or too little oil are both causes of failures.
- If the oil in the work equipment is not clear, there is probably water or air getting into the circuit. In such cases, consult your Komatsu distributor.
- When changing the oil, always replace the related filters at the same time.
- We recommend that you have an oil analysis periodically to check the condition of the machine. For those who wish to use this service, consult your Komatsu distributor.
- When using commercially available oil, it may be necessary to reduce the oil change interval.  
We recommend you to use the Komatsu oil clinic to check the characteristics of the oil in detail.

### FUEL

- To prevent the moisture in the air from condensing and forming water inside the fuel tank, always fill the fuel tank with fuel after completing the day's work.
- The fuel pump is a precision equipment, and if fuel containing water or dirt is used, it cannot work properly.
- Be extremely careful not to let impurities get in when storing or adding fuel.
- Always use the fuel specified for the temperature that is described in Operation and Maintenance Manual.
  - If the fuel is used at the temperatures lower than the specified temperature (particularly at temperatures below - 15 °C {5 °F} ), the fuel will solidify.
  - If the fuel is used at temperatures higher than the specified temperature, the viscosity will drop, and it may result in troubles such as a drop of output.

- Before starting the engine, or after 10 minutes of adding fuel, drain the sediment and water from the fuel tank.
- If the engine runs out of fuel, or if the filters are replaced, it is necessary to bleed the air from the circuit.
- If there is any foreign material in the fuel tank, wash the tank and fuel system.

#### NOTICE

**The fuel used must be ultra low-sulfur diesel fuel.**

To ensure good fuel consumption characteristics and exhaust gas characteristics, the engine mounted on this machine uses an electronically controlled high-pressure fuel injection device. Since the high-pressure fuel injection device requires high precision parts and lubrication, if low viscosity fuel with low lubricating ability is used, its durability may drop considerably. Also, using fuel with high sulfur content may deteriorate the engine parts, inducing failures, decrease of the life and degradation in performance. The ASTM diesel fuel recommended by Komatsu may contain 5 % or less of biofuel. The EN diesel fuel may contain 7 % or less of it. Use the fuel which is filled into the storage tank or the fuel tank of the machine as soon as possible.

When the diesel fuel is changed to the one mixed with the bio-fuel, replace the fuel prefilter cartridge and the fuel main filter cartridge with new ones.

#### COOLANT AND WATER FOR DILUTION

- The coolant has the important function of preventing corrosion as well as preventing freezing. Even in the areas where freezing is not an issue, the use of coolant is essential. Komatsu machines are supplied with Non-Amine Engine Coolant (AF-NAC). Non-Amine Engine Coolant (AF-NAC) has excellent anti-corrosion, antifreeze and cooling properties and can be used continuously for 2 years or 4000 hours. Komatsu recommends the use of Non-Amine Engine Coolant (AF-NAC). If you use another coolant, it may cause serious problems, such as corrosion of the engine and aluminum parts of the cooling system.
- When using antifreeze, always observe the precautions given in Operation and Maintenance Manual.
- Non-Amine Engine Coolant (AF-NAC) is already diluted with distilled water, so it is not flammable.
- The coolant density needs to be changed according to the ambient temperature. Even in areas where it is not considered necessary to prevent freezing, always use Non-Amine Engine Coolant (AF-NAC) with a density of over 30 % in order to prevent corrosion of the cooling system. Non-Amine Engine Coolant (AF-NAC) is diluted with distilled water that does not contain any ions or water-hardening substances. Never dilute it with city water.
- If the engine overheats, wait for the engine to cool before adding coolant.
- If the coolant level is low, it will cause overheating, and will also cause problems with corrosion due to air entering the coolant.

#### GREASE

- Grease is used to prevent seizure and noises at the joints.
- This construction equipment is used under heavy-duty conditions. Komatsu recommends using the recommended grease and follow the replacement intervals and recommended ambient temperatures given in this Operation and Maintenance Manual.
- Grease fittings not included in the periodic maintenance section are the grease fittings for overhaul, so they do not need grease. If any part becomes stiff after being used for long time, add grease.
- Always wipe off all of the old grease that is pushed out when greasing. Be particularly careful to wipe off the old grease in places where sand or dirt sticking in the grease would cause wear of the rotating parts.

**PERFORM KOWA (Komatsu Oil Wear Analysis)**

KOWA is a maintenance service that makes it possible to prevent machine failures and downtime. With KOWA, the oil is periodically sampled and analyzed. This enables early detection of wear of the machine drive parts and other problems.

Thanks to long term experience and ample data accumulated, we can grasp condition of your machine accurately and provide proper recommendation.

We strongly recommend you to use this service. The oil analysis is performed at actual cost, so the cost is low, and results of the analysis and recommendations are reported promptly.

**KOWA analysis items**

Measurement of metallic powder concentration

An ICP (Inductively Coupled Plasma) analyzer is used for measuring the concentration of iron, copper, and other metal powder in the oil.

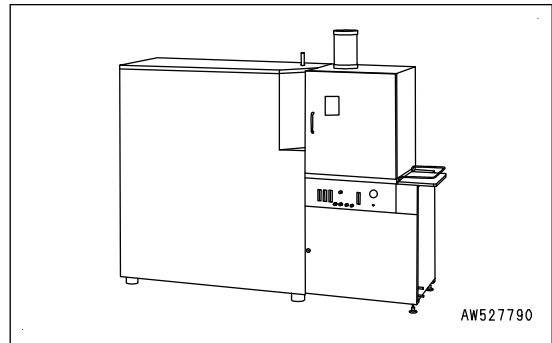

Measurement of quantity of iron particles

A PQI (Particle Quantifier Index) measuring instrument is used for measuring the quantity of iron particles of 5 μm or more, enabling early detection of failures.

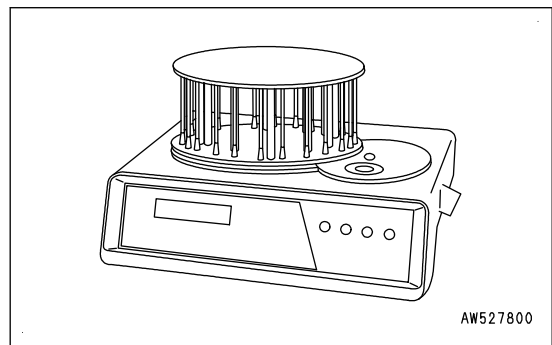

Others

Measurements are made of items such as the ratio of water, coolant, and fuel in the oil, and dynamic viscosity, if necessary, to enable a highly precise diagnosis of the machine and the components' condition.

**Oil sampling interval**

500 hours

**Precautions when sampling**

- Make sure that the oil is well mixed before sampling.
- Perform sampling at regular fixed intervals.
- Do not perform sampling on rainy or windy days when water or dust can get into the oil.

For further details of KOWA, contact your Komatsu distributor.

**STORE OIL AND FUEL**

- Keep oil and fuel indoors to prevent any water, dirt, or other impurities from getting in.
- When keeping drum cans for a long period, lay the drums so that the filler ports of the drums are located in the lower part of the side to prevent moisture from being sucked in. If drums have to be stored outside, cover them with a waterproof sheet or take other measures to protect them.
- To prevent any change in quality during long-term storage, be sure to use in the order of first in - first out (use the oldest oil or fuel first).

## FILTER

- Filters are extremely important safety parts. They prevent impurities in the oil, fuel, and air circuits from entering important equipment and causing problems. Replace all filters periodically. For details, see Operation and Maintenance Manual.  
However, when working in severe conditions, replace the filters at shorter intervals according to the oil and fuel (sulfur content) being used.
- Never try to clean and use again the filters (cartridge type). Always replace them with new filters.
- When replacing oil filters, check if any metal particles are attached to the old filters.  
If any metal particles are found, consult your Komatsu distributor.
- Do not open packages of spare filters until just before they are to be used.
- Komatsu recommends using Komatsu genuine filters.

## HANDLE ELECTRICAL COMPONENTS

### WARNING

- **When the battery disconnect switch key is turned to OFF position for the maintenance work, always pull out the key and keep it with you. If the key is left in the switch, someone may turn ON the power by mistake. It is dangerous that causes an electric shock.**
  - **It is extremely dangerous if the electrical component becomes wet or the covering of the wiring is damaged. This will cause an electrical leakage and may lead to malfunction of the machine. Do not wash the inside of the operator's cab with water. When washing the machine, be careful not to let water get into the electrical components.**
- 
- When removing the connectors of electrical components after washing the machine or in the rain, wipe off the water drop stuck around connectors before removing the connectors and keep the water drop away from inside of the connectors.
  - Checking and maintenance items are checking fan belt tension, checking damage of the fan belt and checking battery fluid level.
  - Komatsu recommends installing electric components specified by Komatsu.
  - External electro-magnetic interference may cause malfunction of the control system controller. Accordingly, consult your Komatsu distributor before installing a radio receiver or other wireless equipment to the machine.
  - When working at the seashore, carefully clean the electric system to prevent corrosion.
  - When installing electrical component, connect it to the special power supply connector.  
Do not connect the optional power supply to the fuse or starting switch or battery relay, etc.



# STANDARD TIGHTENING TORQUE FOR BOLTS AND NUTS

## Tightening torque list

**⚠ CAUTION**

If nuts, bolts, or other parts are not tightened to the specified torque, it will cause looseness or damage to the tightened parts, and this will cause failure of the machine or problems with operation. Always be careful when tightening parts.

Unless otherwise specified, tighten the metric nuts and bolts to the torque shown in the table below.

If it is necessary to replace any nut or bolt, Komatsu recommends using Komatsu genuine part of the same size as the part that is removed.

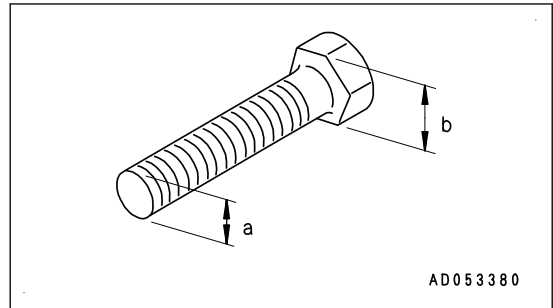

Thread diameter of bolt "a" (mm)	Width across flats "b" (mm)	Tightening torque					
		Target value			Allowable range		
		Nm	kgm	lbft	Nm	kgm	lbft
6	10	13.3	1.35	9.8	11.8 to 14.7	1.2 to 1.5	8.7 to 10.8
8	13	31	3.2	22.8	27 to 34	2.8 to 3.5	20.3 to 25.3
10	17	67	6.8	48.8	59 to 74	6 to 7.5	43.4 to 54.2
12	19	111	11.3	81.4	98 to 123	10 to 12.5	72.3 to 90.4
14	22	172	17.5	127	153 to 190	15.5 to 19.5	112 to 141
16	24	260	26.5	192	235 to 285	23.5 to 29.5	170 to 213
18	27	360	37	268	320 to 400	33 to 41	239 to 297
20	30	510	52.3	378	455 to 565	46.5 to 58	336 to 420
22	32	688	70.3	508	610 to 765	62.5 to 78	452 to 564
24	36	883	90	651	785 to 980	80 to 100	579 to 753
27	41	1295	133	957	1150 to 1440	118 to 147	853 to 1060
30	46	1715	175	1265	1520 to 1910	155 to 195	1120 to 1410
33	50	2205	225	1630	1960 to 2450	200 to 250	1450 to 1810
36	55	2745	280	2025	2450 to 3040	250 to 310	1810 to 2240
39	60	3260	333	2405	2890 to 3630	295 to 370	2130 to 2680

Tighten the hoses to the torque shown in the table.

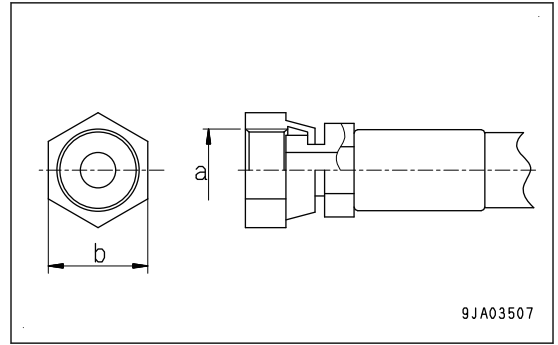

Nominal - No. of threads "a"	Width across flats "b" (mm)	Tightening torque					
		Target value			Allowable range		
		Nm	kgm	lbft	Nm	kgm	lbft
9/16-18UNF	19	44	4.5	32.5	35 to 54	3.5 to 5.5	25.3 to 39.8
11/16-16UN	22	74	7.5	54.2	54 to 93	5.5 to 9.5	39.8 to 68.7
13/16-16UN	27	103	10.5	75.9	84 to 132	8.5 to 13.5	61.5 to 97.6
1-14UNS	32	157	16.0	115.7	128 to 186	13.0 to 19.0	94.0 to 137.4
1 3/16-12UN	36	216	22.0	159.1	177 to 245	18.0 to 25.0	130.2 to 180.8

# MAINTENANCE SCHEDULE

- If the machine is equipped with a hydraulic breaker, the maintenance schedule for some parts are different. When maintaining the machine, check “MAINTENANCE INTERVAL FOR HYDRAULIC BREAKER” for the maintenance interval.
- When using the engine oil for cold district, the maintenance intervals of the engine oil and filter cartridge are changed to for every 250 hours.
- If the currently used diesel fuel which does not include the bio-fuel is changed to the one mixed with the bio-fuel, the replacement interval of the fuel filter is changed as well. See “MAINTENANCE INTERVAL WHEN DIESEL FUEL MIXED WITH BIO-FUEL IS USED”.
- Contact your Komatsu distributor for changing the maintenance interval of the machine monitor.

## MAINTENANCE SCHEDULE TABLE

WHEN REQUIRED ..... 4-13

  METHOD FOR CHECKING, CLEANING AND REPLACING AIR CLEANER ..... 4-13

  METHOD FOR CLEANING INSIDE OF COOLING SYSTEM ..... 4-18

  METHOD FOR CHECKING LOOSENESS AND TIGHTENING TRACK SHOE BOLTS ..... 4-23

  METHOD FOR CHECKING LOOSENESS AND TIGHTENING ROAD LINER SHOE BOLTS ..... 4-24

  METHOD FOR CHECKING AND ADJUSTING TRACK TENSION ..... 4-25

  METHOD FOR CHECKING ROAD LINER..... 4-27

  METHOD FOR REPLACING ROAD LINER..... 4-27

  METHOD FOR CHECKING RUBBER SHOES ..... 4-27

  METHOD FOR CHECKING AND ADJUSTING RUBBER SHOES TRACK TENSION ..... 4-29

  METHOD FOR REPLACING RUBBER SHOES ..... 4-30

  METHOD FOR CHANGING SHOES ..... 4-33

  METHOD FOR REPLACING BUCKET TEETH (VERTICAL PIN TYPE) ..... 4-34

  METHOD FOR REPLACING BUCKET TEETH (HORIZONTAL PIN TYPE)..... 4-37

  METHOD FOR ADJUSTING BUCKET CLEARANCE ..... 4-39

  METHOD FOR CHECKING WINDOW WASHER FLUID LEVEL, ADDING FLUID ..... 4-40

  METHOD FOR CHECKING AND MAINTENANCE AIR CONDITIONER..... 4-41

  METHOD FOR CHECKING, CLEANING AND LUBRICATING SLIDE DOOR RAIL AND ROLLER ..... 4-43

  METHOD FOR CHECKING STOPPER CLEARANCE IN OPENING FRONT DOOR IS UP ..... 4-44

  METHOD FOR REPLACING ADDITIONAL FILTER ELEMENT FOR BREAKER ..... 4-45

  METHOD FOR WASHING WASHABLE FLOOR ..... 4-46

  METHOD FOR CHECKING GAS SPRING ..... 4-49

  METHOD FOR BLEEDING AIR FROM HYDRAULIC CIRCUIT ..... 4-50

CHECKS BEFORE STARTING..... 4-53

EVERY 100 HOURS MAINTENANCE ..... 4-54

  METHOD FOR LUBRICATING WORK EQUIPMENT ..... 4-54

  METHOD FOR CHECKING OIL LEVEL IN SWING MACHINERY CASE, ADDING OIL ..... 4-55

EVERY 250 HOURS MAINTENANCE ..... 4-56

  METHOD FOR CHECKING OIL LEVEL IN FINAL DRIVE CASE, ADDING OIL ..... 4-56

  METHOD FOR CHECKING BATTERY ELECTROLYTE LEVEL ..... 4-57

  METHOD FOR CHECKING AND ADJUSTING AIR CONDITIONER COMPRESSOR BELT TENSION.. 4-60

EVERY 500 HOURS MAINTENANCE ..... 4-62

  METHOD FOR LUBRICATING ..... 4-62

  METHOD FOR CHANGING OIL IN ENGINE OIL PAN, REPLACING ENGINE OIL FILTER CARTRIDGE ..... 4-65

  ..... 4-65

  METHOD FOR REPLACING FUEL PREFILTER CARTRIDGE..... 4-67

  METHOD FOR CHECKING SWING PINION GREASE LEVEL, ADD GREASE ..... 4-70

  METHOD FOR LUBRICATING SWING CIRCLE ..... 4-70

  METHOD FOR CHECKING AND CLEANING RADIATOR FINS, OIL COOLER FINS, AFTERCOOLER FINS, FUEL COOLER FINS, AND AIR CONDITIONER CONDENSER FINS..... 4-71

  METHOD FOR CLEANING AIR CONDITIONER FRESH/RECIRC AIR FILTERS..... 4-73

  METHOD FOR REPLACING HYDRAULIC TANK BREATHER ELEMENT ..... 4-74

EVERY 1000 HOURS MAINTENANCE ..... 4-75

  METHOD FOR REPLACING HYDRAULIC OIL FILTER ELEMENT ..... 4-75

  METHOD FOR CHANGE OIL IN SWING MACHINERY CASE ..... 4-77

METHOD FOR CHANGING OIL IN FINAL DRIVE CASE ..... 4-78  
 METHOD FOR CHECKING OIL LEVEL IN PTO GEAR CASE, ADDING OIL ..... 4-79  
 METHOD FOR REPLACING FUEL MAIN FILTER CARTRIDGE ..... 4-80  
 METHOD FOR CHECKING ALL TIGHTENING POINTS OF ENGINE INTAKE PIPE CLAMPS ..... 4-82  
 METHOD FOR CHECKING FAN BELT TENSION AND REPLACING FAN BELT ..... 4-82  
 EVERY 2000 HOURS MAINTENANCE ..... 4-83  
   METHOD FOR CHECKING AND RELEASING NITROGEN GAS CHARGE PRESSURE IN ACCUMULATOR (FOR CONTROL CIRCUIT) ..... 4-83  
   METHOD FOR CHECKING ALTERNATOR AND STARTING MOTOR ..... 4-86  
   METHOD FOR CHECKING AND ADJUSTING ENGINE VALVE CLEARANCE ..... 4-86  
   METHOD FOR REPLACING KCCV FILTER ELEMENT ..... 4-87  
 EVERY 4000 HOURS MAINTENANCE ..... 4-91  
   REPLACE DEFINED LIFE PARTS ..... 4-91  
   METHOD FOR CHECKING WATER PUMP ..... 4-92  
   METHOD FOR REPLACING ACCUMULATOR (FOR CONTROL CIRCUIT) ..... 4-92  
   METHOD FOR CHECKING FOR LOOSENESS OF ENGINE HIGH-PRESSURE PIPING CLAMP, HARDENING OF RUBBER ..... 4-93  
   METHOD FOR CHECKING FOR MISSING FUEL SPRAY PREVENTION CAP, HARDENING OF RUBBER. .... 4-93  
 EVERY 5000 HOURS MAINTENANCE ..... 4-94  
   METHOD FOR CHANGING OIL IN HYDRAULIC TANK, CLEANING HYDRAULIC TANK STRAINER... 4-94

**MAINTENANCE INTERVAL FOR HYDRAULIC BREAKER**

For machine equipped with a hydraulic breaker, the hydraulic oil deteriorates faster than for normal bucket digging operations, so set the maintenance intervals as follows.

**Replace hydraulic filter element**

On a new machine, replace the element after the first 100 to 150 hours, then perform further replacement of the element according to the table.

**Change oil in hydraulic tank**

Change the oil according to the table.

**Replace additional filter element for breaker (if equipped)**

Use a guideline of 250 hours for use of the breaker (operating ratio of the breaker: 50% or more), and replace the element according to the table.

- X: Breaker operating ratio (%)
- Y: Replacement interval (H)
- (A): Element of hydraulic tank
- (B): Hydraulic oil
- (C): Element of additional filter

**REMARK**

Breaker operating ratio 100% means that only the breaker is used  
 Breaker operating ratio 0% means that the breaker is not used

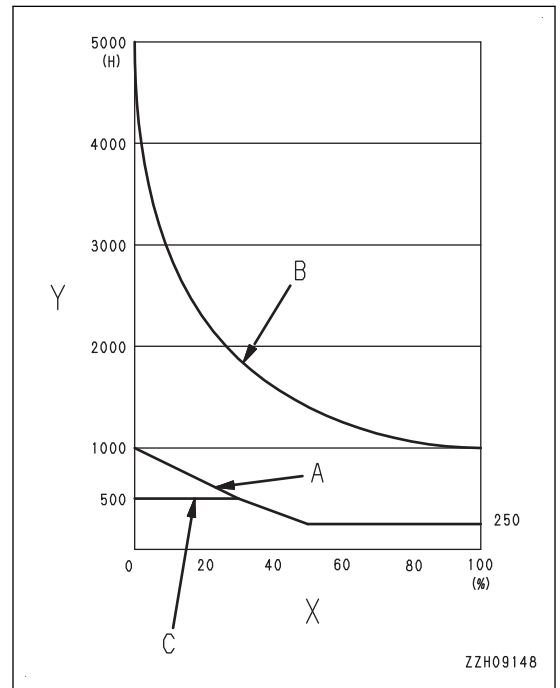

ZZH09148

## MAINTENANCE INTERVAL WHEN DIESEL FUEL MIXED WITH BIO-FUEL IS USED

If the diesel fuel which does not include the bio-fuel is changed to the diesel fuel mixed with bio-fuel, set the maintenance interval as follows.

### Replace the fuel prefilter cartridge

When the machine is operated first 250 hours after the diesel fuel has been changed to the diesel fuel mixed with bio-fuel, and when the machine is operated further 250 hours.

After that, replace it within 500 hours as a periodic replacement by the service meter reading.

### Replace the fuel main filter cartridge

When the machine is operated first 250 hours after the diesel fuel has been changed to the diesel fuel mixed with bio-fuel, and when the machine is operated further 250 hours.

After that, replace it within 1000 hours as a periodic replacement by the service meter reading.

### Maintenance interval after the diesel fuel has been changed to the diesel fuel mixed with bio-fuel

	Operating hours of the machine			Service meter			
	When changed	250 hours after changing	500 hours after changing	Every 500 hours		Every 1000 hours	
				Within 500 operating hours after changing	After 500 operating hours after changing	Within 500 operating hours after changing	After 500 operating hours after changing
Fuel prefilter cartridge	Replace.	Replace.	Replace.	-	Replace.	-	Replace.
Fuel main filter cartridge	Replace.	Replace.	Replace.	-	-	-	Replace.

# MAINTENANCE PROCEDURE

## WHEN REQUIRED

### METHOD FOR CHECKING, CLEANING AND REPLACING AIR CLEANER

#### WARNING

When using compressed air, there is a danger that dirt may scatter and cause personal injury. Always wear personal protective items such as protective eyeglasses and dust mask.

#### NOTICE

If inspection, cleaning, or maintenance is performed while the engine is running, dirt enters into the engine and damages it. Be sure to stop the engine before performing these works.

#### Check

1. Open engine hood (1).
2. Securely lock the hood with hood support lever (2).

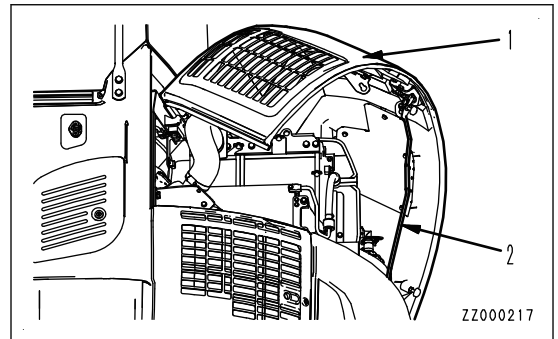

#### NOTICE

Do not clean the element before the red piston is projected into the transparent part of dust indicator (3).

If the element is cleaned frequently before the red piston protrudes, the air cleaner cannot display its normal performance and the cleaning effect decreases.

3. Check if the red piston is projected into the transparent part of dust indicator (3).  
If the red piston is projected, clean the air cleaner element.

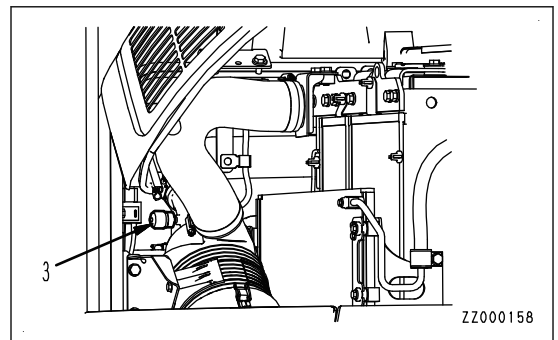

#### Clean outer element

1. Open battery inspection cover (4) on the left side of the machine.

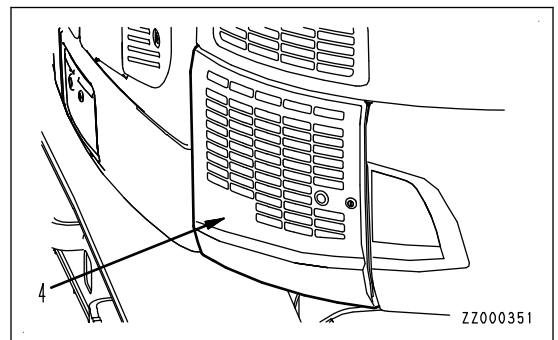

2. Remove clips (5) (3 pieces) and remove cover (6).

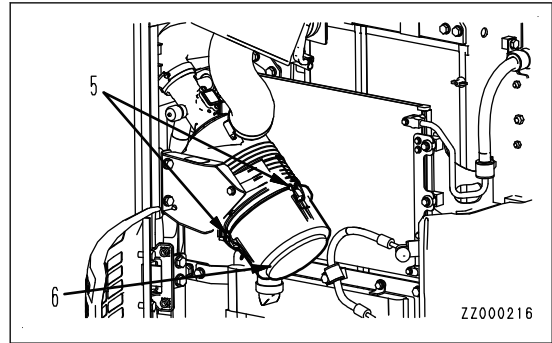

**NOTICE**

**Never remove inner element (8). Dusts may enter, causing the engine failure.**

3. Remove outer element (7).

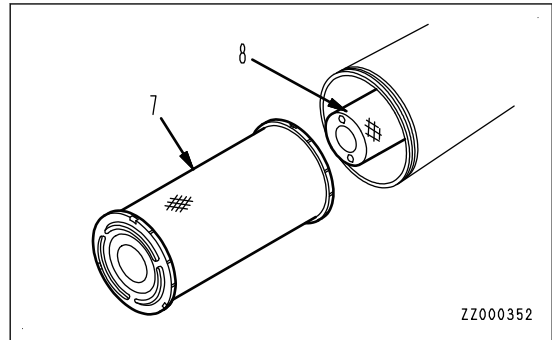

**NOTICE**

**When cleaning cover (6), do not remove vacuator valve (9).**

4. Clean the inside of the air cleaner body and cover (6).
5. Replace outer element (7) after you have cleaned 6 times or it has been used for a year.
  - When the element needs to be replaced  
Replace the inner and outer elements with new ones.  
For details, see "REPLACE ELEMENT".  
Go to "REPLACE ELEMENT".
  - When the element does not need to be replaced  
Clean outer element (7).  
Continue the cleaning procedure.

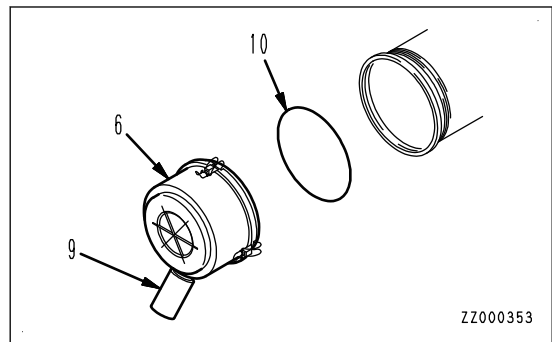

**NOTICE**

**Do not clean and reuse inner element (8). When replacing outer element (7), replace the inner element with new one as well.**

**When cleaning the element, do not tap it or hit it against something.**

**Do not use the element with damaged pleats or a damaged gasket or seal.**

**Wrap an unused element and keep it in a dry place.**

6. Blow dry compressed air (0.2 MPa {2.1 kg/cm<sup>2</sup>, 30.0 PSI} or less) from the inside of the outer element (7) along the pleats.
7. Blow along the folds from the outside, then blow again from the inside.

Replace both inner and outer elements when the dust indicator (3) indicates red soon after cleaning the outer element even though it has not been cleaned 6 times yet.

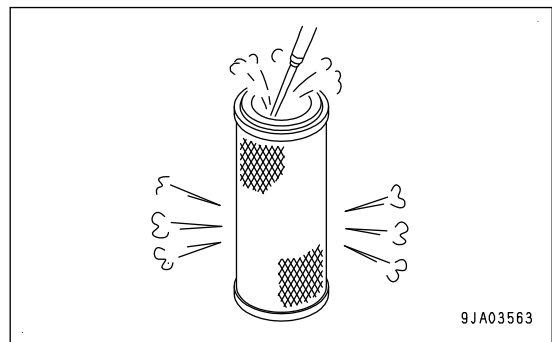

- Peel off a seal after cleaning the element each time.

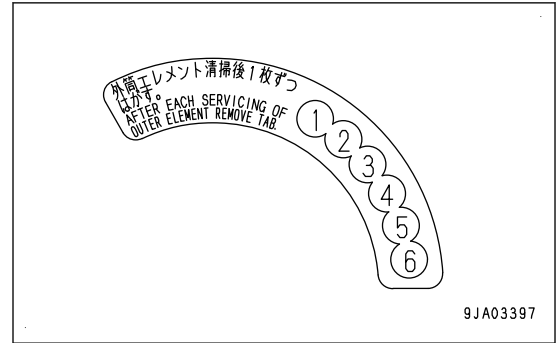

8. After cleaning, illuminate the inside of the element with an electric bulb to check. If any holes or thin places are found, replace the outer element.  
If the element has a small hole or thin part, replace it.

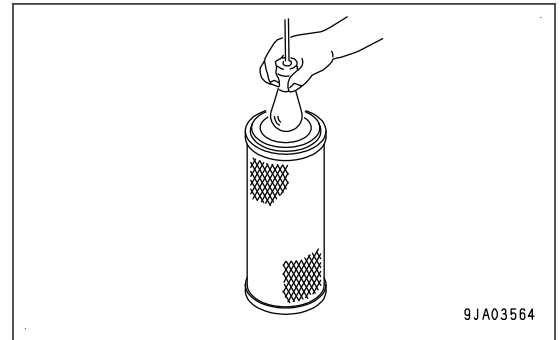

**CAUTION**

When installing the cover (6), check O-ring (10) for scratches or damages and replace O-ring with a new one if any.

9. Install cover (6) according to the following procedure.
  - 1) Set cleaned outer element (7).
  - 2) Align matchmarks (11) on the body and cover (6).
  - 3) Install cover (6) and fix it with clip (5).

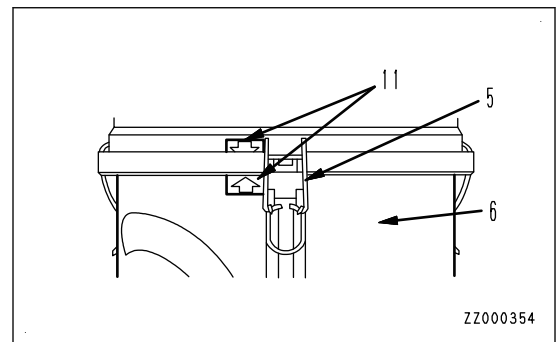

10. Press the button of dust indicator (3) and return the red piston.

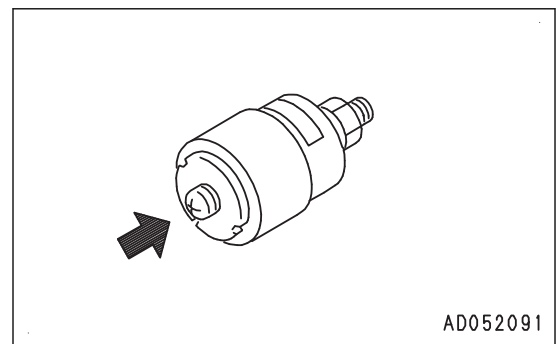



### Replace element

1. Open battery inspection cover (4) on the left side of the machine.

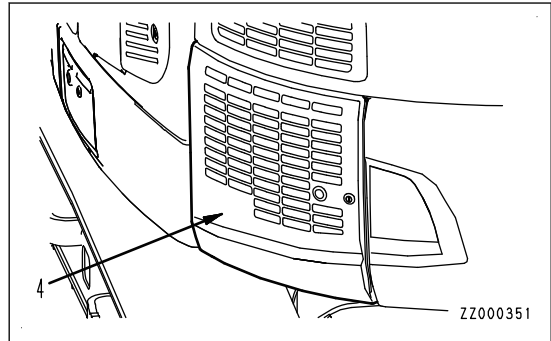

2. Remove clips (5) (3 pieces) and remove cover (6).

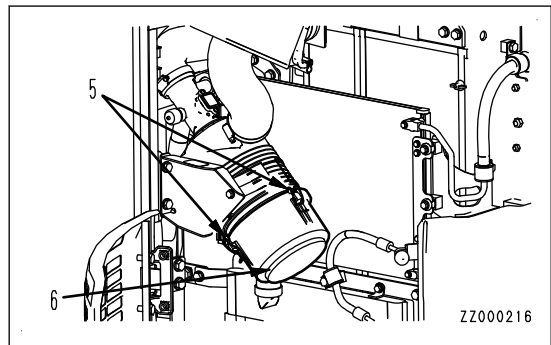

3. Remove outer element (7).  
Do not remove inner element (8) at this time.

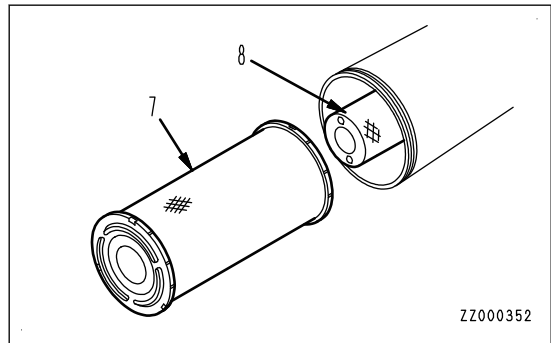

#### NOTICE

**When cleaning cover (6), do not remove vacuator valve (9).**

4. Clean the inside of the air cleaner body and cover (6).
5. Remove inner element (8), then quickly install the new inner element.

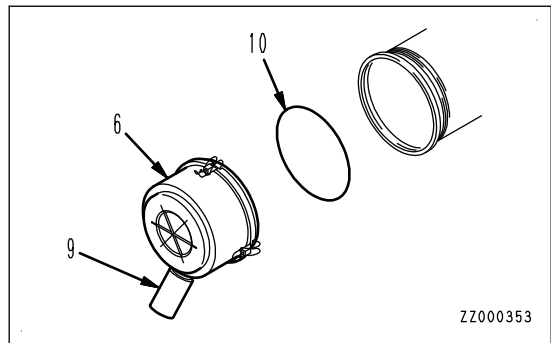

### **⚠ CAUTION**

**When installing the cover (6), check O-ring (10) for scratches or damages and replace O-ring with a new one if any.**

6. Install cover (6) according to the following procedure.

- 1) Set a new outer element (7).
- 2) Align matchmarks (11) on the body and cover (6).
- 3) Install cover (6) and fix it with clip (5).

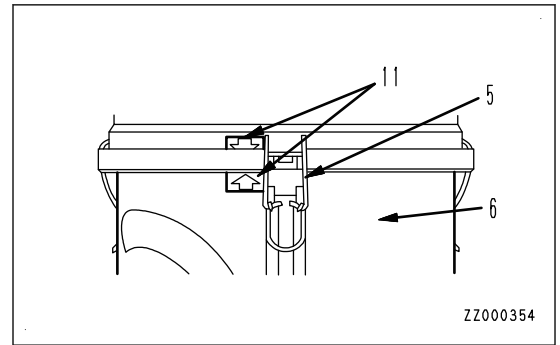

7. Replace the seal stuck to cover (6) with a new one.

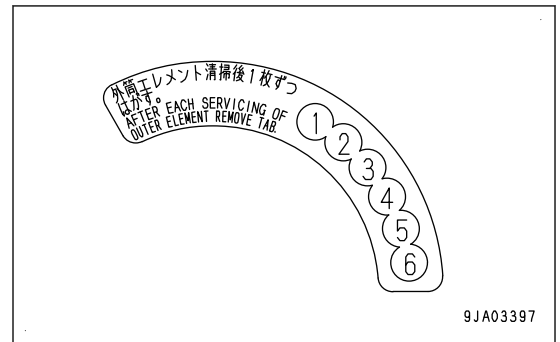

8. Press the button of dust indicator (3) and return the red piston.

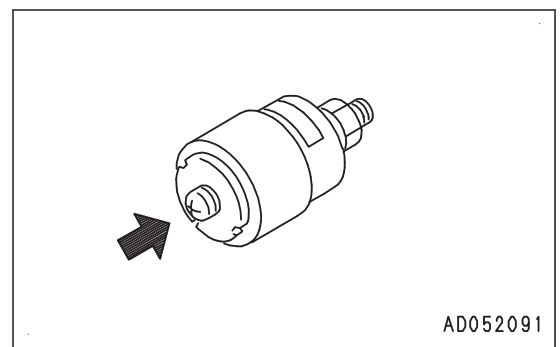

**METHOD FOR CLEANING INSIDE OF COOLING SYSTEM**

** WARNING**

- Immediately after the engine is stopped, the coolant is still hot and the pressure is accumulated in the radiator. If the cap is removed under this condition and the coolant is drained, it may cause burns. Accordingly, wait until the coolant temperature drops, then turn the cap slowly to release the pressure.
- Start the engine and clean the inside of the cooling system. When standing up or leaving the operator's seat, set the lock lever to LOCK position.
- Since the engine is operated during washing, it is dangerous to stand at the rear of the machine when the machine moves accidentally. Never stand at the rear of the machine while the engine is running.

Place the machine on a level ground when cleaning or changing the coolant.

Clean the inside of the cooling system, change the coolant according to the table below.

Coolant	Interval for cleaning inside of cooling system and changing coolant
Non-Amine Engine Coolant (AF-NAC)	Every 2 years or every 4000 hours whichever comes sooner

The coolant has the important function of preventing corrosion as well as preventing freezing.

Even in the areas where freezing is not an issue, the use of coolant is essential.

Komatsu machines are supplied with Non-Amine Engine Coolant (AF-NAC). Non-Amine Engine Coolant (AF-NAC) has excellent anticorrosion, antifreeze and cooling properties and can be used continuously for 2 years or 4000 hours.

Komatsu recommends the use of Non-Amine Engine Coolant (AF-NAC). If you use another coolant, it may cause serious problems, such as corrosion of the engine and aluminum parts of the cooling system.

To maintain the anticorrosion properties of Non-Amine Engine Coolant (AF-NAC), always keep the density of Non-Amine Engine Coolant between 30% and 64%.

Non-Amine Engine Coolant (AF-NAC) is already diluted with distilled water. When using coolant, investigate the lowest temperature in the past and decide the density for the coolant from the coolant density table below.

When deciding the density for the coolant, set it for a temperature 10 °C {18 °F} below the actual lowest temperature in the working area.

The coolant density varies according to the ambient temperature, but it must be over 30 % at least.

**Coolant density table**

Min. atmospheric temperature	°C	Min. -10	-15	-20	-25	-30	-35	-40	-45	-50
	°F	Min. 14	5	-4	-13	-22	-31	-40	-49	-58
Density ( %)		30	36	41	46	50	54	58	61	64

** WARNING**

- Coolant is toxic. When opening the drain valve, be careful not to get coolant on you. If it gets in your eyes, flush your eyes with large amount of fresh water and see a doctor immediately.
- When handling the cooling water containing coolant that has been drained during changing the coolant or repair of radiator, contact your Komatsu distributor or request a qualified company to perform the operation. Coolant is toxic, so never pour it into drainage ditches or drain it onto the ground surface.

Non-Amine Engine Coolant (AF-NAC) is already diluted with distilled water, so it is not flammable.

Check the density with a coolant tester.

Prepare a container whose capacity is larger than the specified coolant volume to catch drained coolant.

Prepare a hose to use when filling with coolant and water.

1. Stop the engine.
2. Open engine hood (1).
3. Lock securely with hood support lever (2).

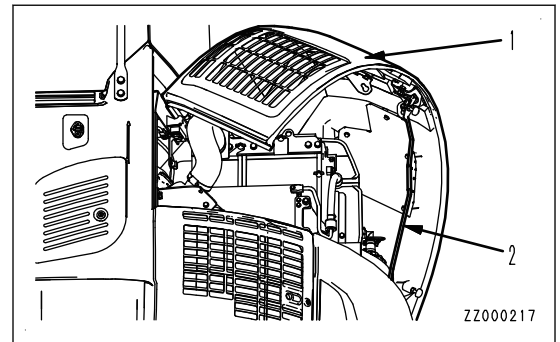

4. Remove cover mounting bolt (3) (3 places) and remove undercover (4).

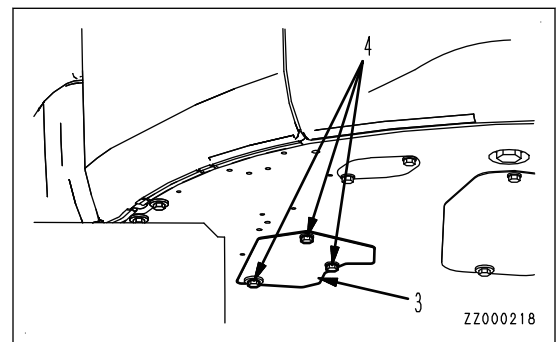

5. Remove center cover (5) and inspection cover (6).

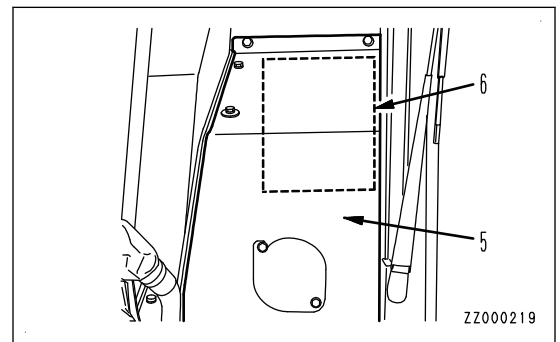

6. Check that the coolant temperature is low enough to make it possible to touch the radiator cap surface by bare hand, turn radiator cap (7) slowly until it hits the stopper, and release the pressure.

7. Then, while pushing radiator cap (7), turn it until it touches the stopper, and remove it.

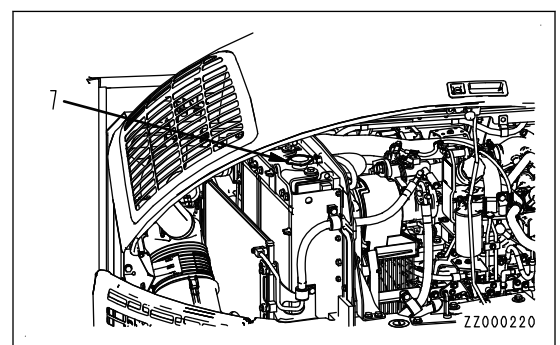

8. Place containers to catch the coolant under the drain hose installed to drain valve (8) and under coolant drain plug (9) of the engine cylinder block.
9. Open drain valve (8) at the bottom of the radiator.
10. Remove drain plug (9) of the cylinder block and drain the coolant.
11. After draining the coolant, close drain valve (8).
12. Tighten drain plug (9) and add city water.  
Add water until it fills the radiator.
13. Start the engine.

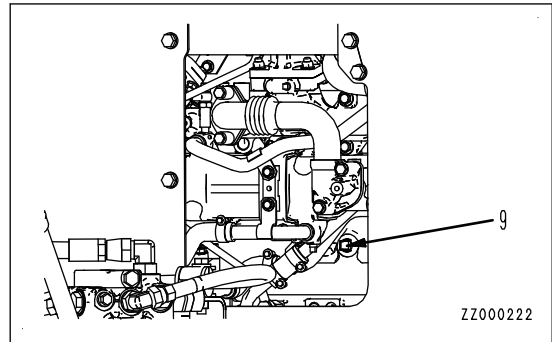
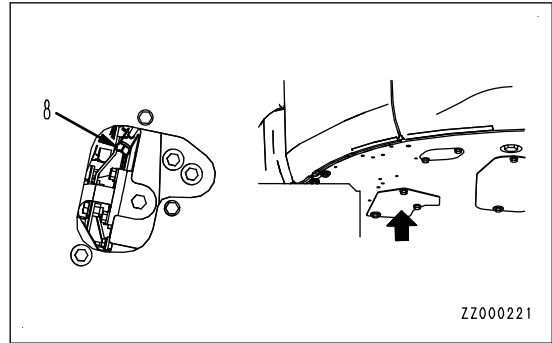

14. To complete the warm-up operation of the hydraulic equipment more quickly, set the working mode to P mode (heavy-duty mode).

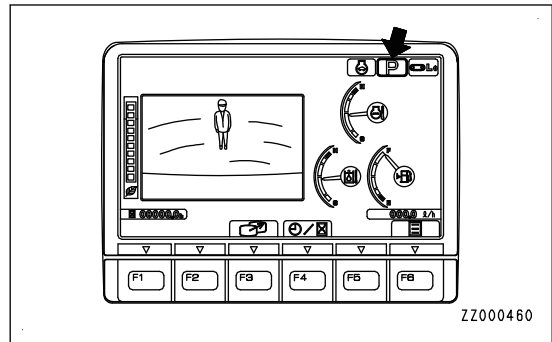

15. Move the lock lever slowly to FREE position (F).
16. Raise the bucket from the ground.

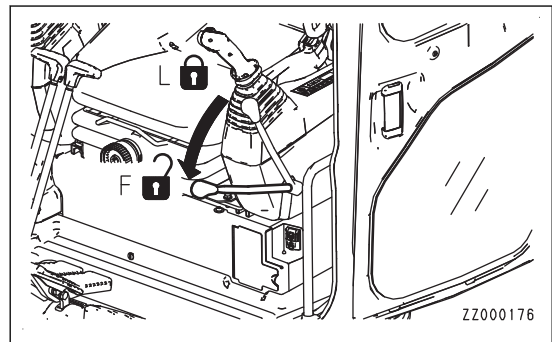

17. Turn the fuel control dial to a point of 2/3 between Low idle (MIN) position and High idle (MAX) position.

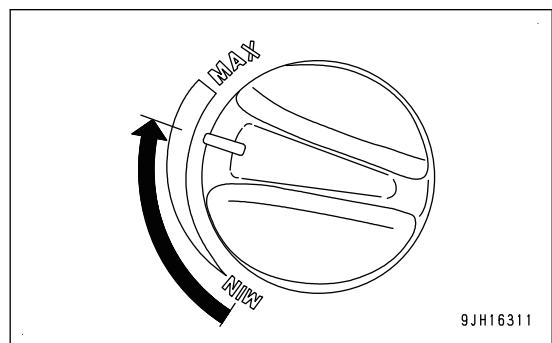

18. Operate the work equipment control levers according to the following procedure.

**NOTICE**

**When the work equipment is operated, take care that it does not interfere with the machine or ground.**

- 1) Move R.H. work equipment control lever slowly in the direction of bucket CURL position (D). Operate the lever to the end of its stroke and hold it in the position for 30 seconds.
- 2) Move R.H. work equipment control lever slowly in the direction bucket DUMP position (C). Operate the lever to the end of its stroke and hold it in the position for 30 seconds.
- 3) Next, move L.H. work equipment control lever slowly in the direction arm IN position (B). Operate the lever to the end of its stroke and hold it in the position for 30 seconds.
- 4) Move L.H. work equipment control lever slowly in the direction arm OUT position (A). Operate the lever to the end of its stroke and hold it in the position for 30 seconds.

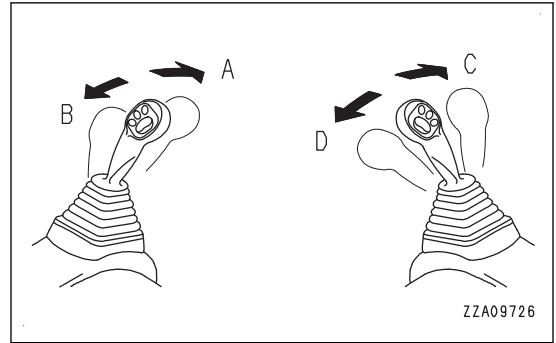

Repeating the operations from step 1 to 4 moves the pointer of the engine coolant temperature caution lamp (4) upward. The pointer of the engine coolant temperature caution lamp moves down temporarily around the center of gauge (A). Then, continue the operation for approximately 10 minutes.

19. Stop the engine.
20. Open drain valve (8).
21. Remove drain plug (9) and drain the coolant.
22. After draining the coolant, close drain valve (8).
23. Wind a sealing tape onto drain plug (9) and tighten the plug.
24. Install covers (3), (5), and (6).
25. Add coolant through the water filler port up to the mouth of the port.  
For details of the coolant density, see “coolant density table”.
26. Run the engine at low idle for 5 minutes to remove the air from the coolant, then run at high idle for a further 5 minutes.

Keep radiator cap (7) removed during the above operations.

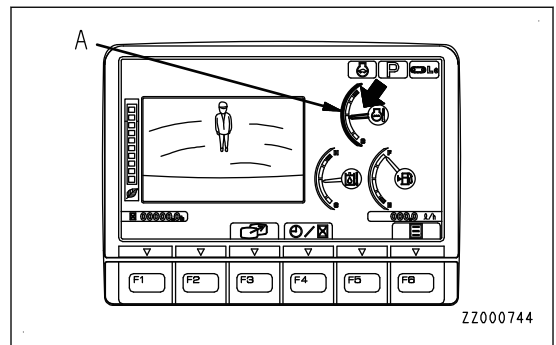

27. Drain the coolant in reservoir tank (10).
28. Clean the inside of the reservoir tank.
29. Add coolant up to the middle between FULL and LOW.
30. Stop the engine.
31. Approximately 3 minutes later, add coolant to near the mouth of the water filler port.
32. Tighten radiator cap (7).

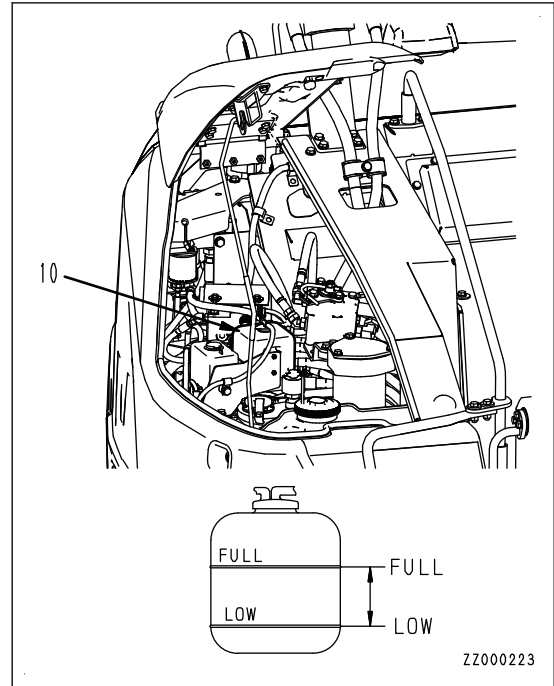

## METHOD FOR CHECKING LOOSENESS AND TIGHTENING TRACK SHOE BOLTS

(Steel shoe specification)

### NOTICE

If the machine is used with track shoe bolts loose, they will break. Tighten any loose shoe bolts immediately.

1. Check for looseness of the track shoe bolt (1).

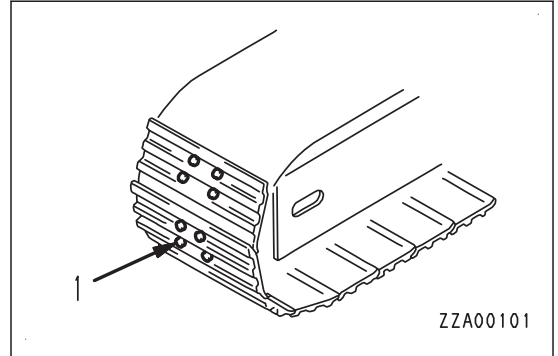

2. If any looseness of the bolt is found, tighten it in order shown in the figure.

Tightening torque: 98.1 to 137 Nm {10 to 14 kgm, 72.3 to 101 lbft}

3. Check that the nut and shoe are in close contact with the link contact surface.
4. After checking, tighten a further 80 to 100 °.

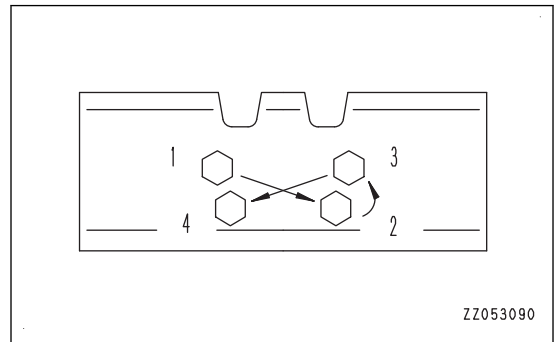



## METHOD FOR CHECKING LOOSENESS AND TIGHTENING ROAD LINER SHOE BOLTS

### NOTICE

If the machine is used with road liner shoe bolts loose, they will break. Tighten any loose shoe bolts immediately.

1. Check for looseness of the road liner shoe bolt (1).

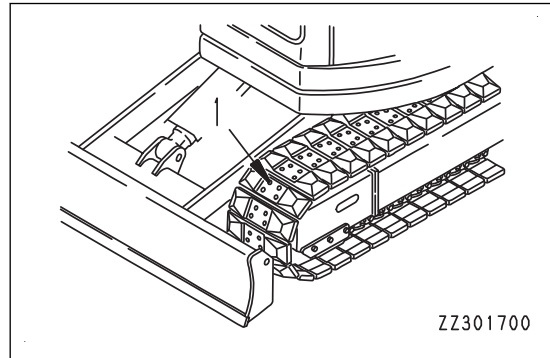

2. If any looseness of the bolt is found, tighten it in order shown in the figure.

Tightening: 177 to 216 Nm {18 to 22 kgm, 130 to 159 lbft}

3. Check that the nut and shoe are in close contact with the link contact surface.

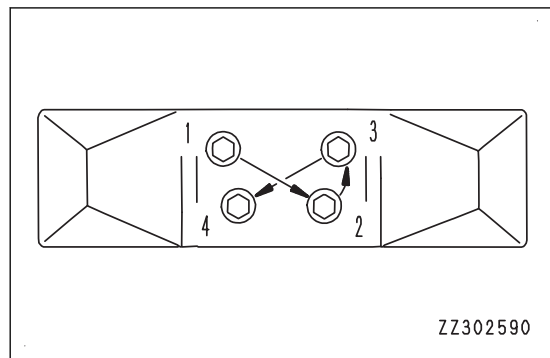

## METHOD FOR CHECKING AND ADJUSTING TRACK TENSION

(Steel shoe and road liner specification)

Wear on pins and bushings of the undercarriage vary with working conditions and type of soil, so inspect the track tension at any time convenient in order to maintain the standard tension.

For performing the inspection and adjustment of the track shoes, park the machine on the level and firm ground.

### Check

1. Run the engine at low idle, then move the machine forward for a distance equal to the track length on ground, and slowly stop the machine.
2. Place straight wooden square bar (3) which reaches from idler (1) to carrier roller (2) on the track.
3. Measure the maximum deflection (a) between the bottom surface of the wooden bar and top surface of the track shoes.

Standard deflection:

Deflection (a) should be 10 to 30 mm {0.4 to 1.2 in} .

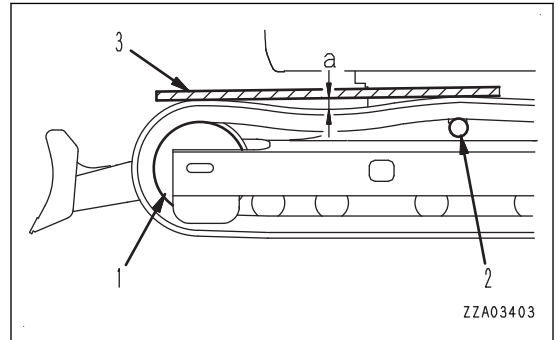

If the deflection is out of the standard range, adjust it into the standard range.

### Increase track tension

Prepare a grease pump.

1. Pump in grease through grease fitting (4) by using a grease pump.
2. To check if the tension is correct, run the engine at low idle, move the machine slowly forward (by an amount equal to the length of track on ground), then stop the machine.

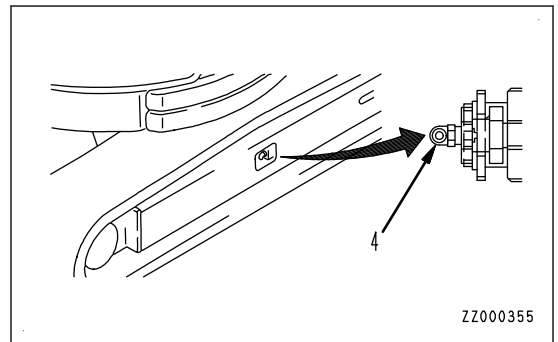

3. Check the track tension again, and if the tension is not correct, adjust it again.

Continue to pump in grease until S becomes 0 mm. If the tension is still loose, the pins and bushings are excessively worn, so they must be either turned 180 deg. or replaced.

Ask your Komatsu distributor for repair.

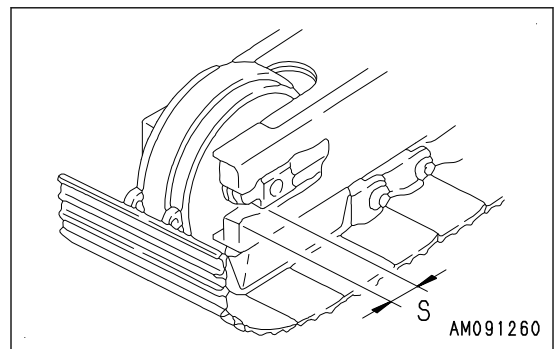

**Decrease track tension**

**⚠ WARNING**

- **Never loosen plug (5) more than 1 turn.**  
**If plug (5) is loosened more than 1 turn, there is a danger of plug (5) flying out under the high internal pressure of the grease.**  
**Never loosen any part other than plug (5). Never put your face in the mounting direction of plug (5).**
- **It is extremely dangerous to release the grease by any method other than the procedure shown here.**  
**If track tension is not relieved by this procedure, contact your Komatsu distributor for repairs.**

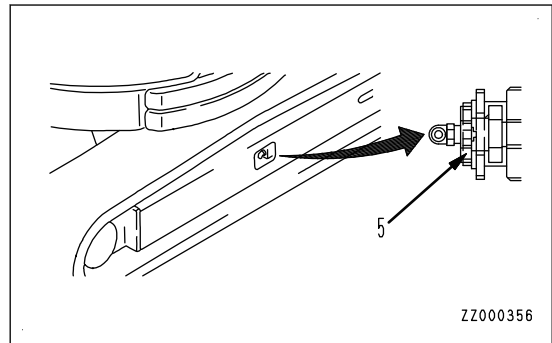

1. Loosen plug (5) gradually to release the grease.  
 When loosening plug (5), turn it a maximum of 1 turn.
2. If the grease does not come out smoothly, move the machine forward and backward a short distance.
3. Tighten plug (5).
4. To check if the tension is correct, run the engine at low idle, move the machine slowly forward (by an amount equal to the length of track on ground), then stop the machine.
5. Check the track tension again, and if the tension is not correct, adjust it again.

### METHOD FOR CHECKING ROAD LINER

(Road liner specification)

If the road liners are in the following condition, they must be replaced. Ask your Komatsu distributor for replacement.

#### Lug height

- When lug height (a) is reduced to 5 mm {0.2 in} or less, replace the road liner with a new one.  
If lug height (a) is reduced by wear, the drawbar pull will drop.

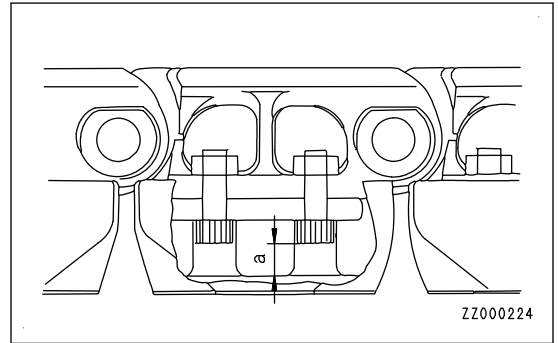

For judgment of replacement, repair, and continuation of use of the road liner, consult your Komatsu distributor.

### METHOD FOR REPLACING ROAD LINER

(Road liner specification)

- When all the road liners of the machine need to be replaced, ask your Komatsu distributor to replace them.
- When replacing only part of the road liner, use the special road liner removal tool. Order the tool from your Komatsu distributor.

### METHOD FOR CHECKING RUBBER SHOES

(Rubber shoe specification)

If the rubber shoe track is in the following condition, it must be repaired or replaced. Ask your Komatsu distributor for repairs or replacement.

#### Lug height

- When lug height (a) is reduced to 5 mm {0.2 in} or less, replace the rubber shoes track with a new one.  
If lug height (a) is reduced by wear, the drawbar pull will drop.

- (1) Track roller
- (2) Rubber shoe

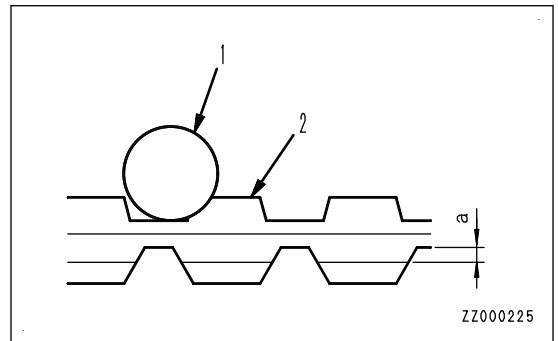

- If the lugs are worn and the steel cords in the shoes are exposed on continuous 2 links, replace the track with a new one.

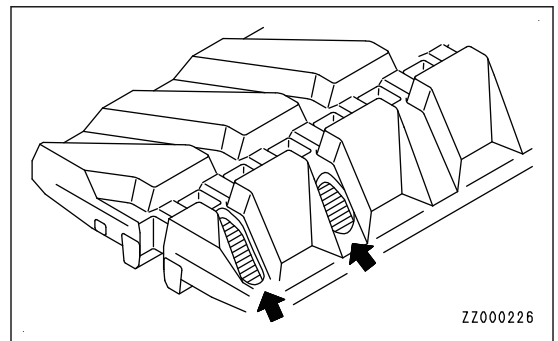

**Cut of rubber shoe steel cords**

If more than a half of the steel cord layer is cut on either side, replace the track with a new one.

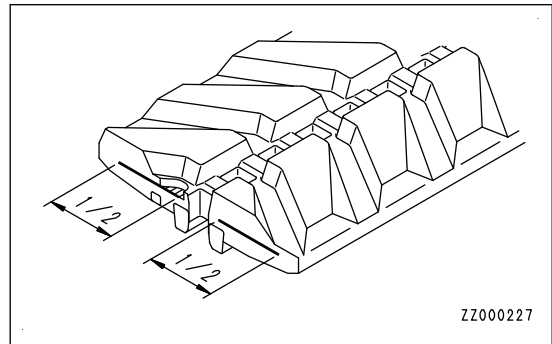

**Separation of rubber shoe core metal**

If the rubber shoe core metals are separated at 1 or more places, replace the track with a new one.

**Rubber shoes track tension**

If the rubber shoe track tension is still low after grease is supplied, replace the track with a new one or replace the seals in the cylinder.

If the rubber shoe track cannot be tensed to a degree that it does not come off, not only the track is lengthened but also the grease cylinder may have trouble.

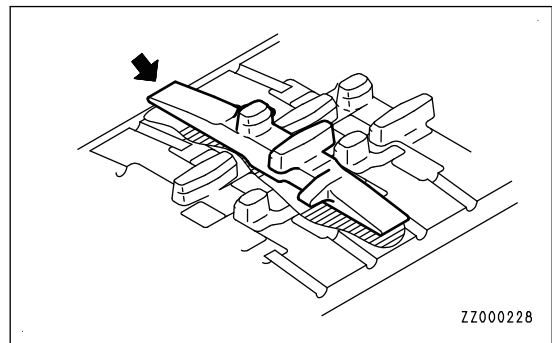

**Crack in rubber shoe track**

When a crack in a rubber shoe lug extends to approximately 60 mm {2.4 in} , repair it.

**NOTICE**

**If a crack occurs and the steel cords are seen, repair it immediately, even if it is small and short.**

A crack up to 30 mm {1.2 in} long or 10 mm {0.4 in} deep does not need to be repaired.

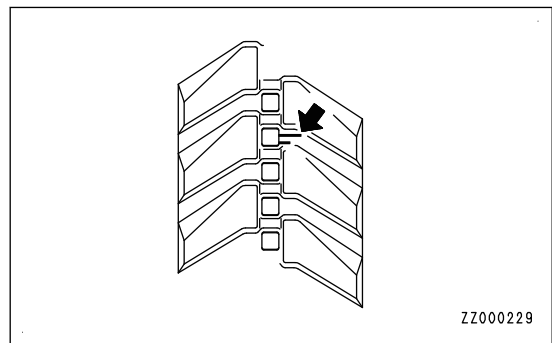

For judgment of replacement, repair, and continuation of use of the rubber shoe track, consult your Komatsu distributor.

## METHOD FOR CHECKING AND ADJUSTING RUBBER SHOES TRACK TENSION

(Rubber shoe specification)

- Wear of the rubber shoe depends on the working condition and type of soil. Accordingly, check the wear and track tension at appropriate intervals. For performing the inspection and adjustment of the track shoes, park the machine on the level and firm ground.
- When the machine is new or a new part is installed, the track becomes loose for 5 to 30 hours after the tension is set to the specified value while the machine travels repeatedly. If you adjust the track tension at short intervals until the initial loosening is finished, “coming off of the track caused by insufficient track tension” is prevented.
- Working with the track loosened can cause coming off of the track and rapid wear of the core metal.

### METHOD FOR CHECKING RUBBER SHOES TRACK TENSION

1. Run the engine at low idle, then move the machine forward for a distance equal to the track length on ground, and slowly stop the machine.
2. Place straight wooden square bar (3) which reaches from idler (1) to carrier roller (2) on the track.
3. Measure maximum deflection (a) between the under surface of the wooden bar and top surface of the track.

Standard deflection:

Deflection (a) should be 1 to 3 mm {0.039 to 0.118 in} .

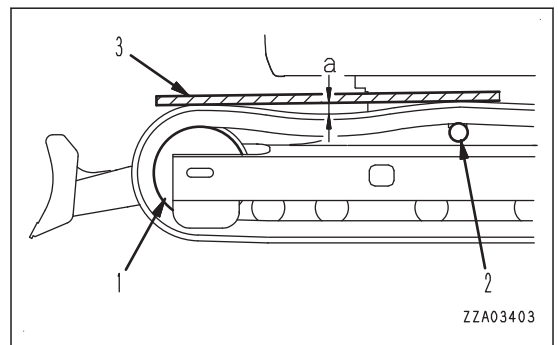

If the deflection is out of the standard range, adjust it into the standard range.

### METHOD FOR INCREASING RUBBER SHOES TRACK TENSION

#### NOTICE

Since the standard value is small, take extreme care not to tense the rubber shoe track too much.

Prepare a grease pump.

1. Pump in grease through grease fitting (4) with a grease pump.
2. To check if the track tension is correct, run the engine at low idle, move the machine slowly forward (by an amount equal to the length of track on ground), then stop the machine.
3. Check the rubber shoe track tension again. If it is not correct, adjust it again.

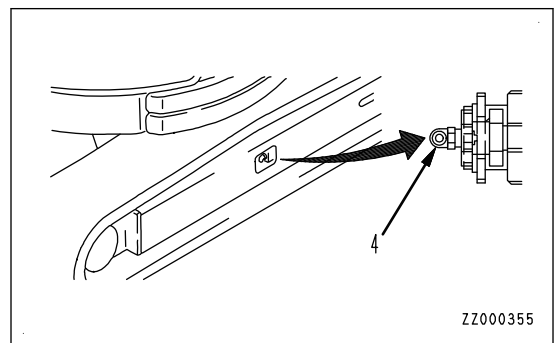

If the tension is still low after the grease is supplied, the rubber shoe track or seals in the cylinder must be replaced. Ask your Komatsu distributor for replacement.

**METHOD FOR DECREASING RUBBER SHOES TRACK TENSION**

**⚠ WARNING**

- Never loosen plug (5) more than 1 turn. If plug (5) is loosened more than 1 turn, there is a danger of plug (5) flying out under the high internal pressure of the grease. Never loosen any part other than plug (5). Never put your face in the mounting direction of plug (5).
- It is extremely dangerous to release the grease by any method other than the procedure shown here. If the rubber shoe track is not loosened, ask your Komatsu distributor for repair.

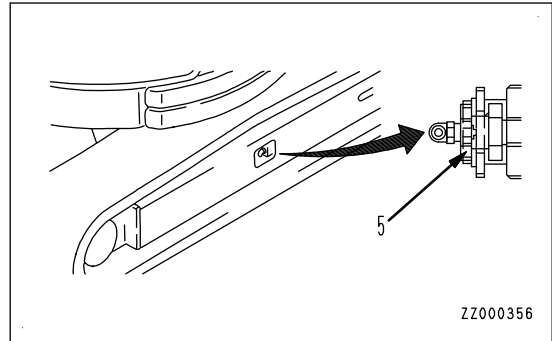

1. Loosen plug (5) gradually to release the grease. When loosening plug (5), turn it a maximum of 1 turn.
2. If the grease does not come out smoothly, move the machine forward and backward a short distance.
3. Tighten plug (5).
4. To check if the track tension is correct, run the engine at low idle, move the machine slowly forward (by an amount equal to the length of track on ground), then stop the machine.
5. Check the rubber shoe track tension again. If it is not correct, adjust it again.

**METHOD FOR REPLACING RUBBER SHOES**

(Rubber shoe specification)

**⚠ WARNING**

- Perform the operation with 2 workers. The operator must operate the machine according to the signs of the worker.
- The machine must be raised to replace the rubber shoes. If the machine falls by accident at this time, it is very dangerous. Never move any part other than the rubber shoes to be replaced during the replacement work. Also, never put any part of your body under the rubber shoes or track frame during the replacement work.

**NOTICE**

The idler cushion must be removed and adjusted when the rubber shoes are replaced with the road liner or steel shoes. Accordingly, be sure to ask your Komatsu distributor for the replacement.

Items to be prepared

- Grease pump
- Steel pipe

**METHOD FOR REMOVING RUBBER SHOES**

**⚠ WARNING**

- Never loosen plug (1) more than 1 turn.  
If plug (1) is loosened more than 1 turn, there is a danger of plug (1) flying out under the high internal pressure of the grease.  
Never loosen any part other than plug (1). Never put your face in the mounting direction of plug (1).
- It is extremely dangerous to release the grease by any method other than the procedure shown here.  
If the rubber shoe track is not loosened, ask your Komatsu distributor for repair.
- Before removing the rubber shoe track, check that the internal grease is fully discharged, and then turn the sprocket.

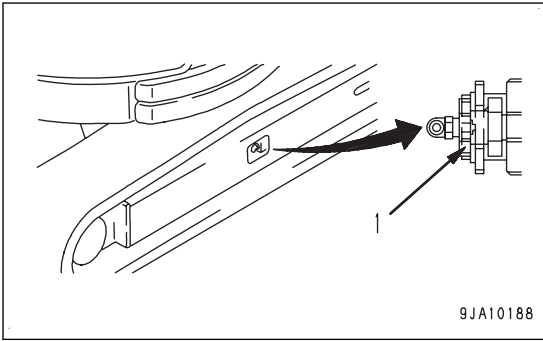

9JA10188

1. Raise the machine off the ground by using the boom and arm.  
When doing this, operate the levers slowly.

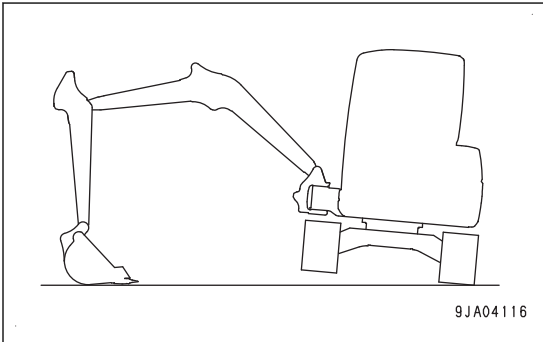

9JA04116

2. Loosen plug (1) gradually to release the grease.  
When loosening plug (1), turn it a maximum of one turn.

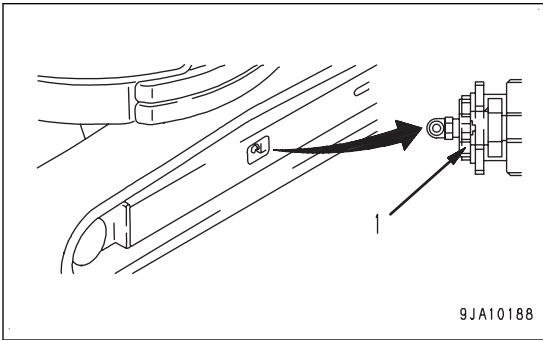

9JA10188

3. Catch steel pipe (2) in the rubber shoe track.
4. Turn the sprocket in reverse direction (A).  
The rubber shoe track is lifted off the idler by steel pipe (2).
5. Slide and remove the rubber shoe track sideways.

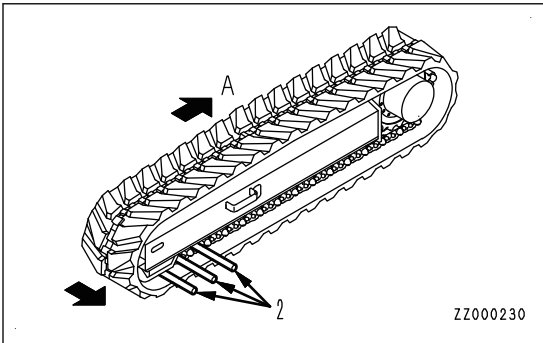

ZZ000230



### METHOD FOR INSTALLING RUBBER SHOES

1. Raise the machine off the ground by using the boom and arm.

When doing this, operate the levers slowly.

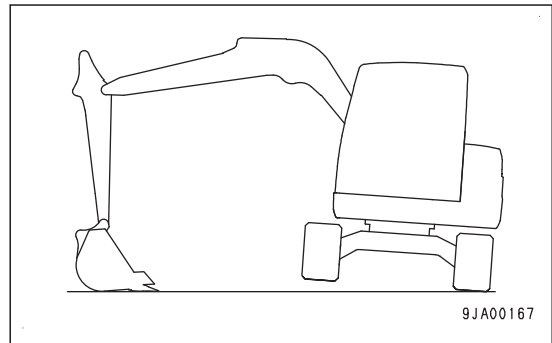

2. Engage the rubber shoe track with the sprocket and place it over the idler.

3. Rotate the sprocket in reverse direction (A), push in the rubber shoe track, and stop the rotation.

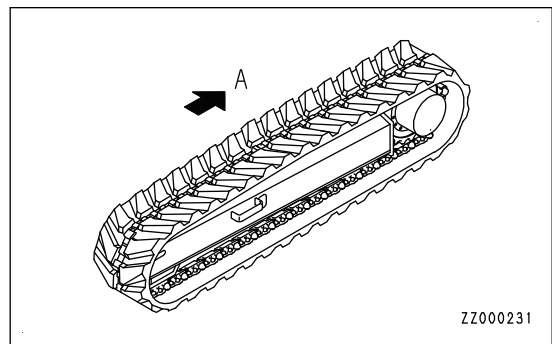

4. Catch steel pipe (2) in the rubber shoe track.
5. Rotate the sprocket again to securely engage the rubber shoe track with the idler.

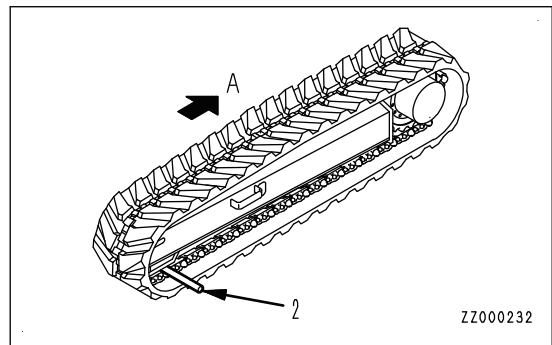

6. Stop the rotation and check that the rubber shoe track is securely engaged with the sprocket and idler.

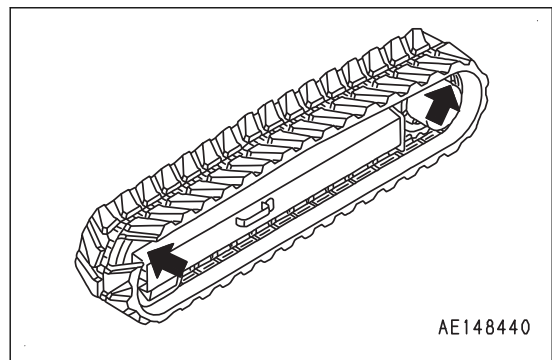

7. Adjust the rubber shoe track tension. For details, see "METHOD FOR CHECKING AND ADJUSTING RUBBER SHOES TRACK TENSION".
8. Check that the rubber shoe track is securely engaged with the sprocket and idler and its tension is proper.
9. Operate the boom and arm and lower the machine.

## METHOD FOR CHANGING SHOES

### WARNING

The idler cushion must be removed and adjusted when the steel shoes or road liner are replaced with the rubber shoes, or reversely. Accordingly, be sure to ask your Komatsu distributor for the replacement.

## METHOD FOR CHANGING FROM STEEL SHOES OR ROADLINERS TO RUBBER SHOES

1. Remove idler guard mounting bolts (1) and remove idler guard (2).
2. Remove the steel shoes or road liner and install the rubber shoes.

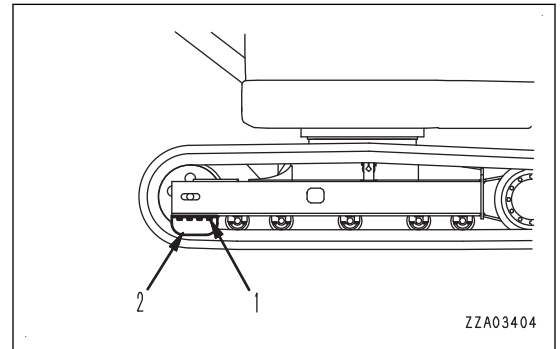

## METHOD FOR CHANGING FROM RUBBER SHOES TO STEEL SHOES OR ROADLINERS

1. Remove the rubber shoes and install the steel shoes or road liner.
2. Install idler guard (2) with idler guard mounting bolts (1).

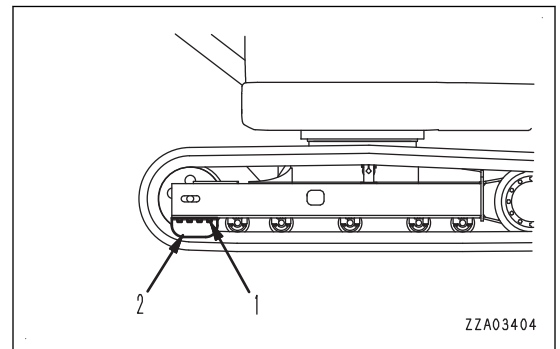

### METHOD FOR REPLACING BUCKET TEETH (VERTICAL PIN TYPE)

Replace the bucket teeth before the adapter starts to wear.

#### **⚠ WARNING**

- It is dangerous if the work equipment moves by mistake when the tooth is being replaced. Set the work equipment in a stable condition, stop the engine and set the lock lever securely to LOCK position.
- As the pin is driven out with strong force, it is dangerous that the pin may fly out. Check that there is no person in the surrounding area.
- Broken pieces may fly during the replacement work, so always wear the personal protective items such as protective eyeglasses and gloves.

Items to be prepared

- Hammer
- Bar

1. To make it possible to drive out a pin of tooth (1), put block (5) under the bottom of the bucket, and make the bottom of the bucket horizontal.

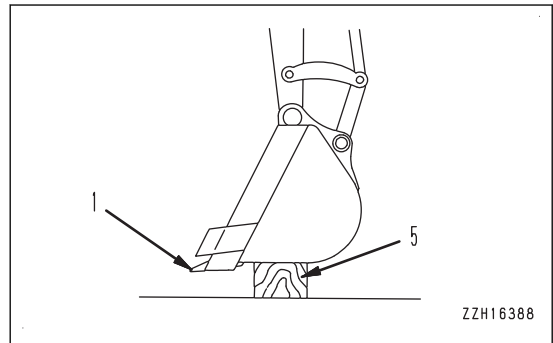

2. Check that the work equipment is in a stable condition, then set the lock lever to LOCK position (L).

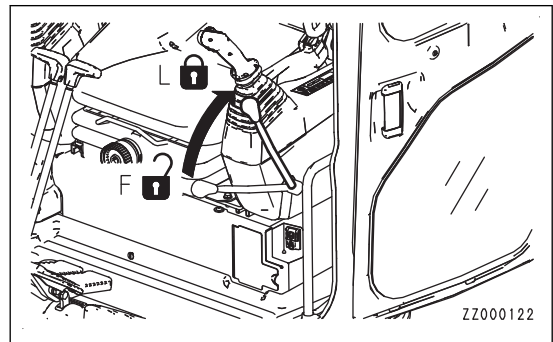

3. Use a hammer and bar to drive out lock pin (2).  
If the bar is set against rubber pin lock (3) when it is hit, the rubber pin lock may break. Set it against the back of the pin.

4. After removing lock pin (2) and rubber pin lock (3), check them.

If lock pin (2) and rubber pin lock (3) are used in the condition below, it will cause tooth (1) to come off during operation. Check the shape of the parts. If they have any damage, replace them.

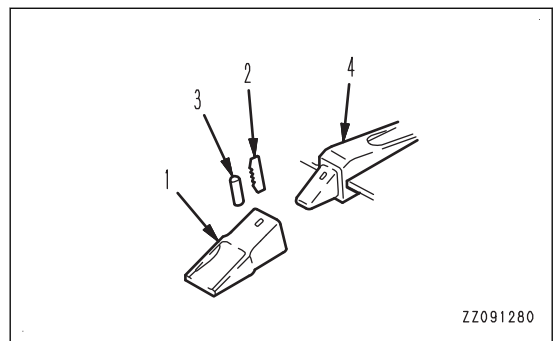

- Lock pin (2) is too short.  
Dimension (B) is 1/3 or more of dimension (A) when lock pin (2) is aligned with bottom face (C).

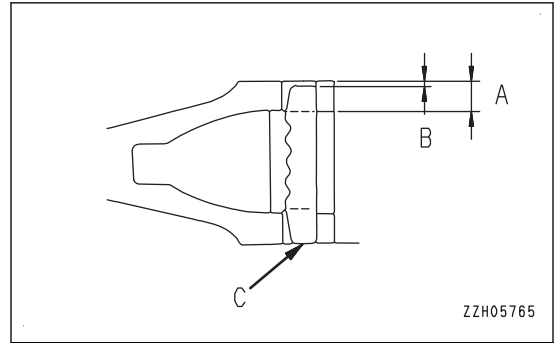

- The steel ball is about to come off.  
Rubber (6) of the rubber pin lock is broken.

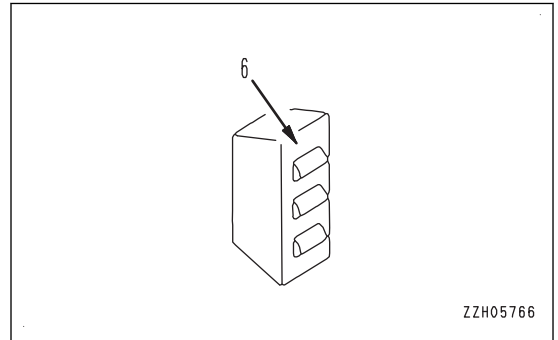

- The steel ball sinks.  
The rubber of the rubber pin lock is deteriorated and steel ball sinks into it when you press it.

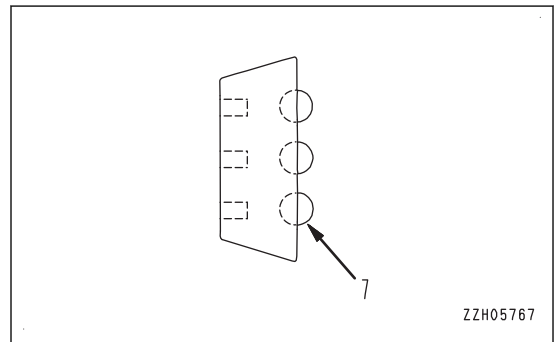

5. Remove the soil stuck to adapter (4) by using a knife.
6. Use your hand or a hammer to push rubber pin lock (3) in to the hole of adapter (4).  
When doing this, be careful that rubber pin lock (3) does not fly out from the adapter surface.
7. Clean the inside of tooth (1), then install it to adapter (4).  
If there is mud affixed to it or if there are protrusions, the tooth (1) will not enter adapter (4) properly, and there will not be proper contact at the mating portion.

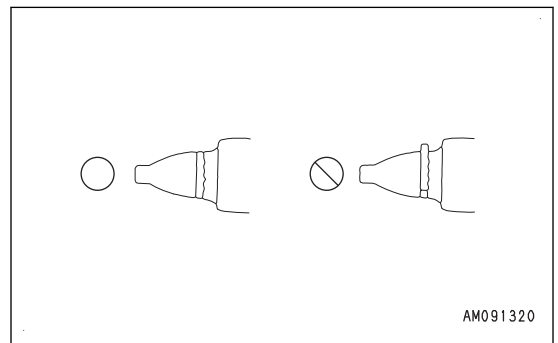

8. Fit tooth (1) to adapter (4), and check that when tooth (1) is pressed strongly, the rear face of the hole for the pin of tooth (1) is at the same level as the rear face of the hole for the pin of adapter (4).  
If the rear face of the pin hole of tooth (1) protrudes in front of the rear face of the pin hole of adapter (4), do not drive the pin in.  
There is sticking matter (C) which prevents tooth (1) from fitting into adapter (4) perfectly.  
Find out remove the sticking matter and fit tooth (1) into adapter (4) sufficiently, and then drive lock pin (2).

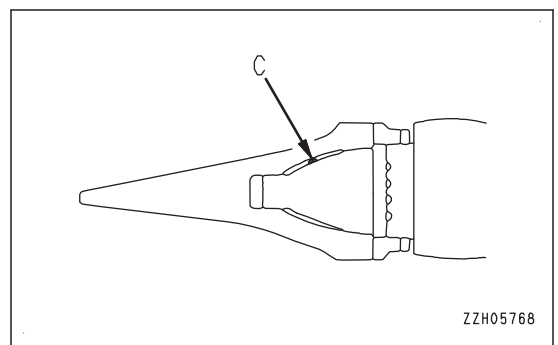

9. Insert lock pin (2) in the pin hole in tooth (1), and drive it in so that the top surface of lock pin (2) is the same height as the surface of tooth (1).

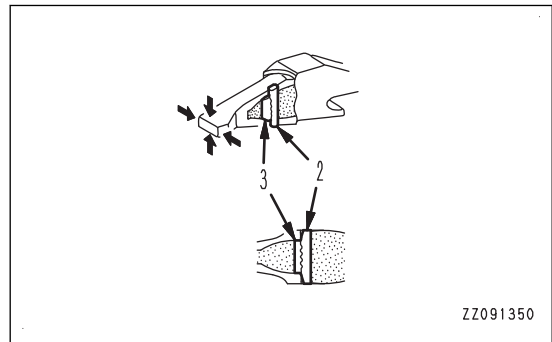
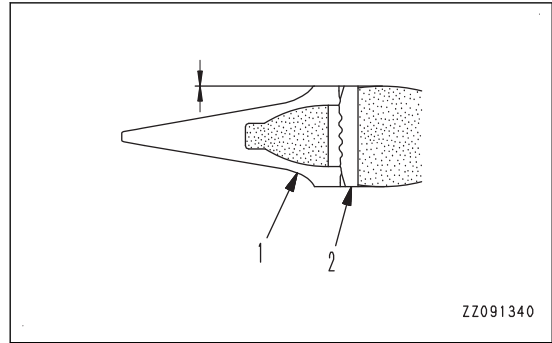

10. After replacing a bucket tooth, always check the following.

- After lock pin (2) is driven in completely, check that it is secured by tooth (1) and surface.
- Lightly hit lock pin (2) in the reverse direction from which it was hit in.
- Lightly hit the tip of tooth (1) from above and below, and hit its sides from right and left.
- Rubber pin lock (3) and lock pin (2) are set as shown in the figure.

**REMARK**

If tooth (1) is turned, the wear will become uniform. This will extend the service life of the tooth and reduce the frequency of replacement.

When replacing tooth (1), replace rubber pin lock (3) and lock pin (2) with new ones as well. This will prevent tooth (1) from falling out.

## METHOD FOR REPLACING BUCKET TEETH (HORIZONTAL PIN TYPE)

Replace the bucket teeth before the adapter starts to wear.

### WARNING

- It is dangerous if the work equipment moves by mistake when the tooth is being replaced. Set the work equipment in a stable condition, stop the engine and set the lock lever securely to LOCK position.
- As the pin is knocked out only with strong force, it is dangerous that the pin may fly out. Check that there is no person in the surrounding area.
- Broken pieces may fly during the replacement work, so always wear the personal protective items such as protective eyeglasses and gloves.

Items to be prepared

- Hammer
  - Bar
1. To pull out pin (1) of tooth (2), put block (5) under the bottom of the bucket, and make the bottom surface of the bucket horizontal.

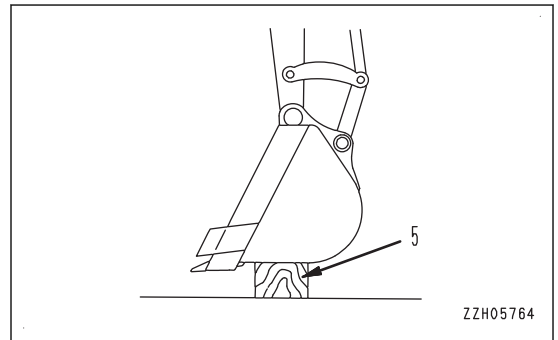

2. Check that the work equipment is in a stable condition, then set the lock lever to LOCK position (L).

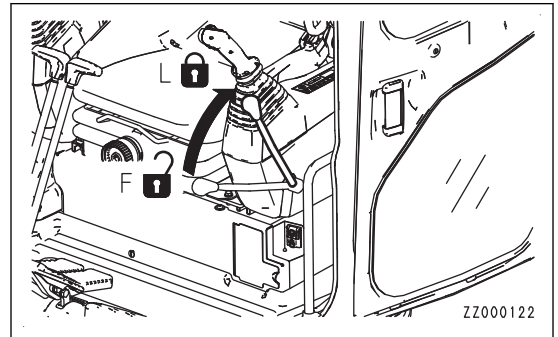

3. Place a bar on the head of pin (1), hit the bar with a hammer to knock out the pin, then remove tooth (2).

#### REMARK

- The bar must be round and thinner than the pin.
- If it cannot be removed by this method, ask your Komatsu distributor to have the replacement performed.

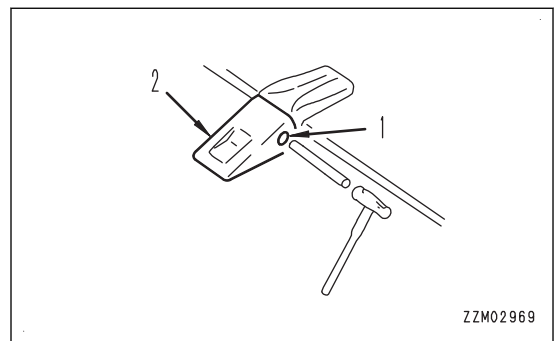

4. Clean the mounting face and fit new tooth (2) to the adapter.
5. Insert pin (1) halfway, and drive it with the hammer to install it to the bucket.

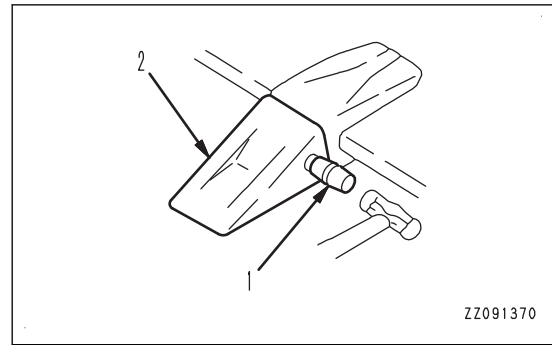

**METHOD FOR ADJUSTING BUCKET CLEARANCE**

**⚠ WARNING**

It is dangerous if the work equipment moves by mistake when adjusting the bucket clearance. Lower the work equipment to the ground, set it in a stable condition, stop the engine, and set the lock lever securely to LOCK position (L).

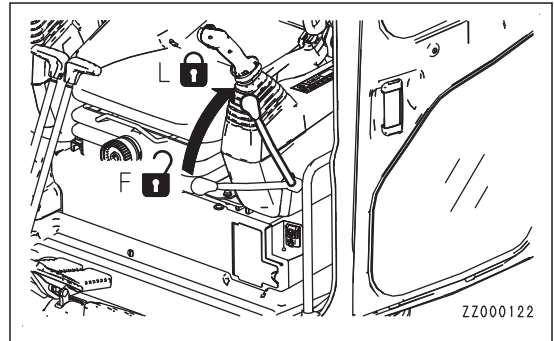

1. Set the work equipment in the position shown in the figure, then stop the engine and set the lock lever to LOCK position (L).  
 A: Arm  
 B: Bucket
2. Shift O-ring (1) and measure the amount of play "a".

**REMARK**

Measurement is easier if you move the bucket to one side so that all the play can be measured at one place (the right side in the figure). Use a clearance gauge for easy and accurate measurement.

3. Loosen plate mounting bolts (2) (4 pieces) and loosen plate (3).  
 The shim is a split type, so the work can be performed without removing the bolts.
4. Remove shim (4) corresponding to the amount of play "a".  
 Shim (4) is a set of 2 pieces. The thickness of each piece of shim (4) is 0.5 mm (0.02 in).  
 When play "a" is smaller than 1 shim, do not adjust it by tightening bolts (2).
5. Tighten bolts (2) (4 pieces).  
 If bolts (2) are too stiff to tighten, pull out pin stopper bolt (5) for easier tightening.

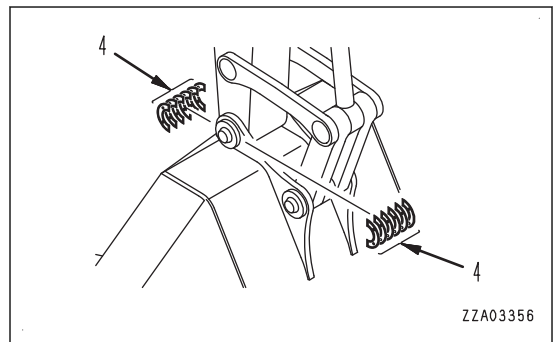
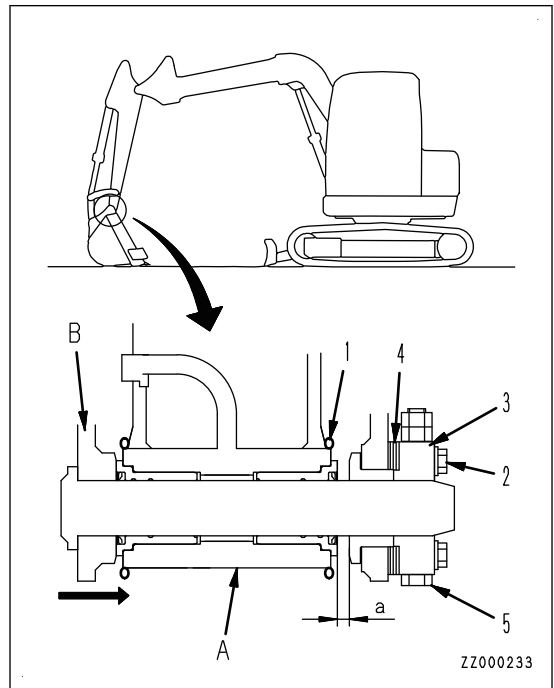



### METHOD FOR CHECKING WINDOW WASHER FLUID LEVEL, ADDING FLUID

If air is in the window washer fluid, check the fluid level in window washer tank (1).

1. Check the fluid level in window washer tank (1).
2. If the level is low, add window washer fluid for automobile.  
Be careful not to let dirt or dust get in when adding fluid.

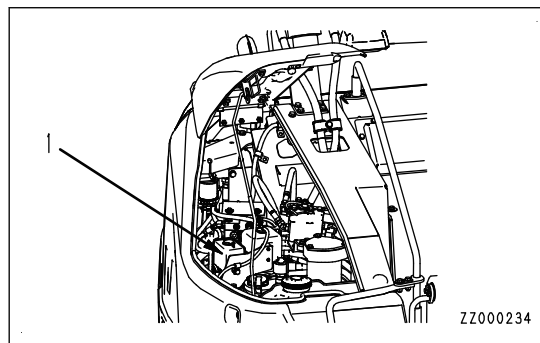

### Mixture ratio of pure washer fluid and water

The proper mixing proportion varies with the ambient temperature. Add washer fluid diluted with water at the following proportion.

Area, season	Mixing proportion	Freezing temperature
Normal	Washer fluid 1/3: water 2/3	-10 °C (14 °F)
Winter in cold district	Washer fluid 1/2: water 1/2	-20 °C (-4 °F)
Winter in extremely cold district	Pure washer fluid	-30 °C (-22 °F)

There are 2 types depending on the freezing temperature: -10 °C (14 °F) (general use) and -30 °C (-22 °F) (cold district use), select according to the area and season.

## METHOD FOR CHECKING AND MAINTENANCE AIR CONDITIONER

### SERVICE ITEM

Some maintenance items of the air conditioner are to be inspected periodically and the others are to be inspected when required. Check and maintenance the air conditioner according to the following list to use it effectively.

Check and maintenance items	Content of check and maintenance	Guideline for maintenance interval
Refrigerant (gas)	Charge amount	Twice a year (spring, autumn)
Air conditioner condenser	Clogged fins	Every 500 hours "METHOD FOR CHECKING AND CLEANING RADIATOR FINS, OIL COOLER FINS, AFTER-COOLER FINS, FUEL COOLER FINS, AND AIR CONDITIONER CONDENSER FINS"
Compressor	Operating condition	Every 4000 hours
V-belt	Damage, tension	Every 250 hours "METHOD FOR CHECKING AND ADJUSTING AIR CONDITIONER COMPRESSOR BELT TENSION"
Blower motor, fan	Operating condition (Check for unusual noise)	When required
Control mechanism	Operating condition (Check that function is normal)	When required
Piping mounts	Mounting condition, looseness at tightening or connecting portions, leakage of gas, damage	When required

Even during the off-season, operate the air conditioner for 3 to 5 minutes once a month to maintain the oil film at all parts of the compressor.

## METHOD FOR CHECKING REFRIGERANT LEVEL FOR AIR CONDITIONER (GAS)

### WARNING

If the refrigerant used in the air conditioner gets into your eyes or is splashed on your hands, it may cause loss of sight or frostbite. Never touch the refrigerant. Do not loosen any part of the refrigerant circuit.

Do not bring any open flame close to any point where the refrigerant gas is leaking.

If the level of the refrigerant (gas) is low, the cooling effect will be reduced. Perform the check while running the engine at high idle and operating the air conditioner at high speed.

Check the condition of the refrigerant gas (Hydrofluorocarbons HFC-134a) that circulates the refrigerant circuit, through sight glass (1) (inspection window) at the refrigerant hose fitting.

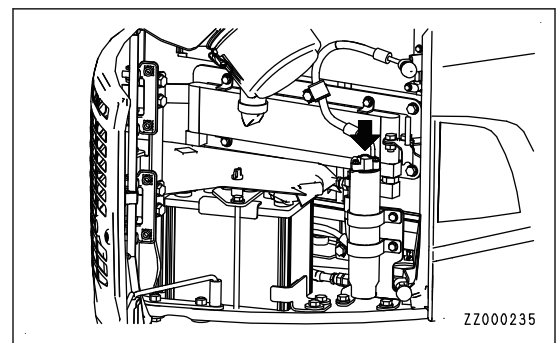

- (A) No bubbles in refrigerant flow: Suitable
- (B) Some bubbles in refrigerant flow (bubbles pass continuously): Insufficient
- (C) Colorless, transparent: No refrigerant

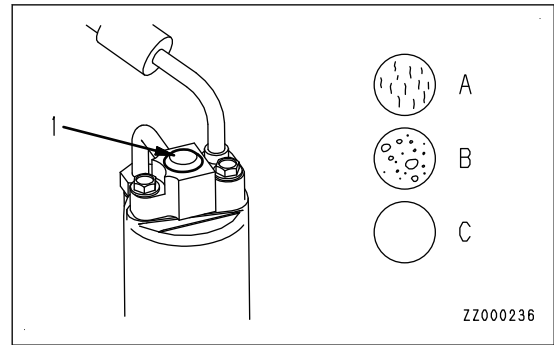

**REMARK**

When there are bubbles, the refrigerant gas level is low, so contact your Komatsu distributor to have refrigerant added. If the air conditioner is run with the refrigerant gas level low, it will cause damage to the compressor.

## METHOD FOR CHECKING, CLEANING AND LUBRICATING SLIDE DOOR RAIL AND ROLLER

### METHOD FOR CHECKING SLIDE DOOR RAIL AND ROLLER

Open and close the sliding door and check if mud, etc. is stuffed between sliding door rail (1) and roller (2) at the 3 places in the figure.

If mud, etc. is stuffed, the door does not move smoothly.

If the door does not slide smoothly due to stuffed mud, etc., clean and grease the sliding door rail (1) and roller (2).

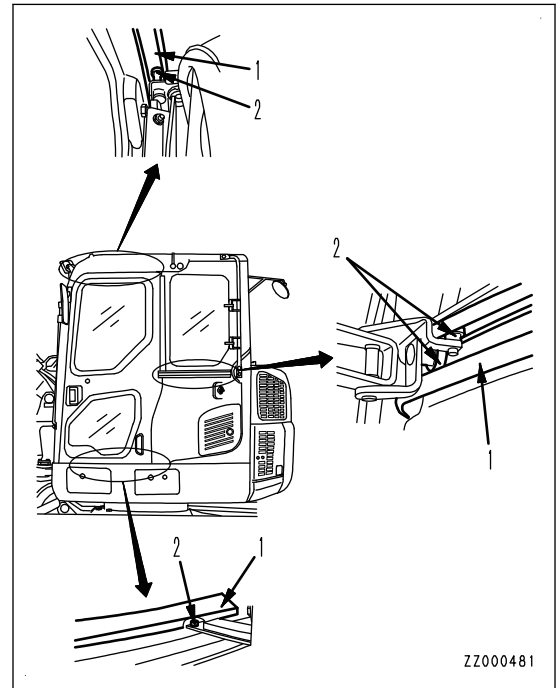

### METHOD FOR CLEANING SLIDE DOOR RAIL

1. Open and close the sliding door, and use a brush to remove any dirt from rail (1).
2. Use a cloth to wipe off any dirt from rail (1).

### METHOD FOR LUBRICATING SLIDE DOOR RAIL AND ROLLER

#### NOTICE

**Do not use high-viscosity lubricating oil.**

**Recommendation by manufacturer: "PANDO 18C" manufactured by THREEBOND**

Prepare lubricant.

1. Spray rail (1) and roller (2) thoroughly with lubricant.
2. After spraying with lubricant, slide the door and check that the door opens and closes smoothly.

If the movement is not smooth, consult your Komatsu distributor.

### METHOD FOR CHECKING, CLEANING AND LUBRICATING SLIDE DOOR STOPPER

Prepare lubricant.

Lubricant recommended by manufacturer: Lithium grease

1. Check if creaks are heard from sliding door stoppers (1) and (2).
  2. If creaks are heard, wipe off dirt from the stoppers.
  3. Grease the stoppers.
- If the stoppers are worn, consult your Komatsu distributor.

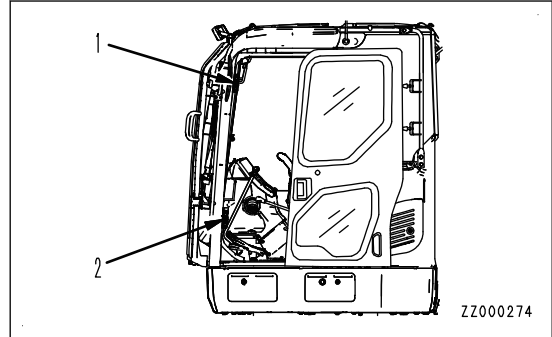

### METHOD FOR CHECKING STOPPER CLEARANCE IN OPENING FRONT DOOR IS UP

#### ⚠ WARNING

- When opening or closing the front window, lower window, or door, always set the lock lever to LOCK position.  
If the lock lever is at FREE position and the control lever or control switch is touched by mistake, it is dangerous and may cause serious personal injury or death.
- When opening or closing the front window, stop the machine on a level ground, lower the work equipment to the ground, stop the engine, then perform the operation.
- When opening the front window, hold the handle securely with both hands, pull up, and do not let go until the lock catch is locked.
- When closing the front window, the window will move quicker under its own weight. Hold the handles securely with both hands when closing it.

If the front window has backlash when it is pulled up, perform the following.

Check if there is clearance (a) between rubber stopper (1) and plastic guide (2).

Rubber stopper (1) may be worn partially, but it does not affect the function as long as there is no backlash or clearance.

If there is any clearance, consult your Komatsu distributor.

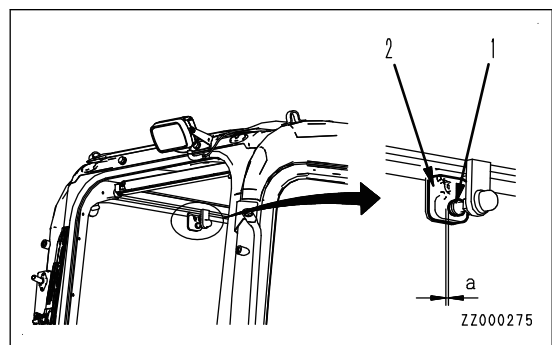

## METHOD FOR REPLACING ADDITIONAL FILTER ELEMENT FOR BREAKER

(if equipped)

### WARNING

- Immediately after the engine is stopped, its parts and oil are still very hot, and may cause burn injury. Accordingly, wait until they have cooled down before starting the work.
- Turn oil filler cap (F) slowly to release the internal pressure, then remove it with care.

### NOTICE

For the element replacement interval, see “MAINTENANCE INTERVAL FOR HYDRAULIC BREAKER”.

Prepare a container to catch oil.

1. Place a container to catch drained oil under the filter element.
2. Turn filter case (1) counterclockwise and remove it.
3. Remove element (2).
4. Remove plug (3) from filter case (1).
5. After checking that the hydraulic oil temperature has dropped, turn filter case (1) counterclockwise, remove it, then take out element (2).
6. Clean the removed parts.
7. Install new element (2).
8. Install filter case (1) and plug (3).

Tighten filter case (1) and plug (3) to the following torque.

Tightening torque

Filter case (1): 58.8 to 78.4 Nm {6 to 8 kgm, 43.4 to 57.9 lbft}

Plug (3): 39.2 to 49 Nm {4 to 5 kgm, 28.9 to 36.2 lbft}

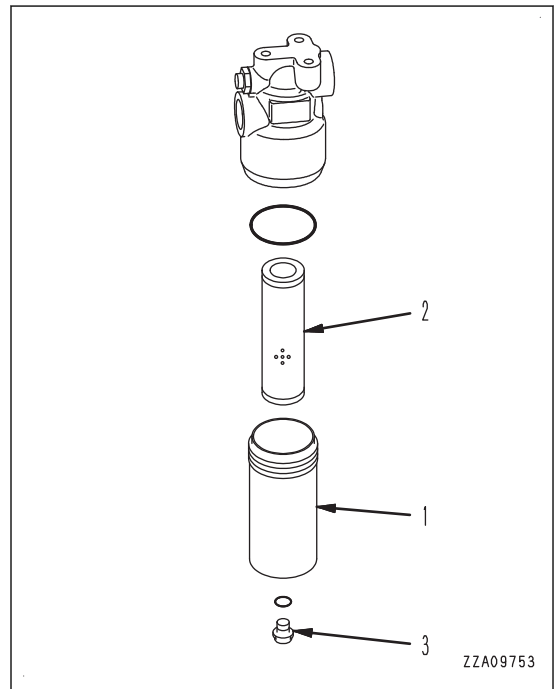
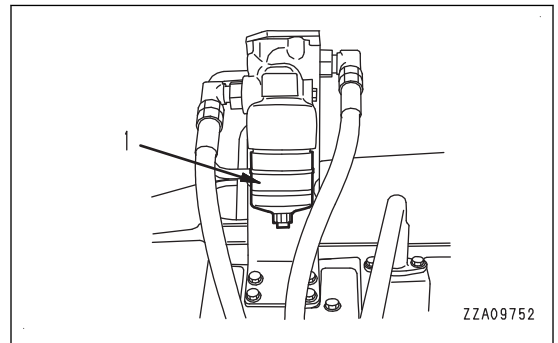

### METHOD FOR WASHING WASHABLE FLOOR

On the washable cab floor, it is possible to flush out the dirt directly with water.

## ⚠ WARNING

Select a firm flat place for work.

When setting the machine at an angle, use strong blocks to stabilize the base of the machine and be extremely careful when performing the work.

If the control lever is touched by accident, the machine may move suddenly, and this may lead to a serious personal injury or death. Always set the lock lever securely to LOCK position (L) before leaving the operator's seat.

### Wash cab floor

#### NOTICE

During the operation, be careful not to get water on the monitor, connector, air conditioner and its filter inside the operator's cab.

1. Set the machine at angle.

Referring to "METHOD FOR SETTING MACHINE AT ANGLE", select a safe method, depending on the state of the machine.

In this example, the machine is set at angle by using blocks.

2. Swing the upper structure slowly so that water drain holes (1) in the cab floor are at a low position.
3. Lower the work equipment to the ground and set the machine in a stable condition.

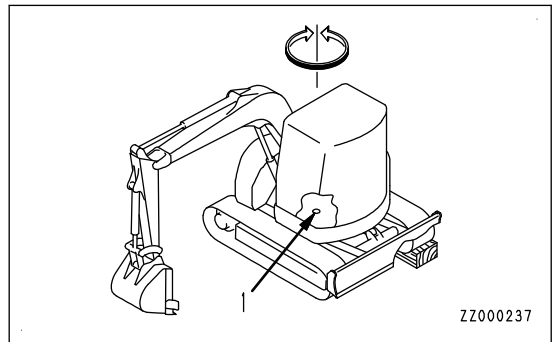

4. Set the lock lever to LOCK position (L).
5. Stop the engine.

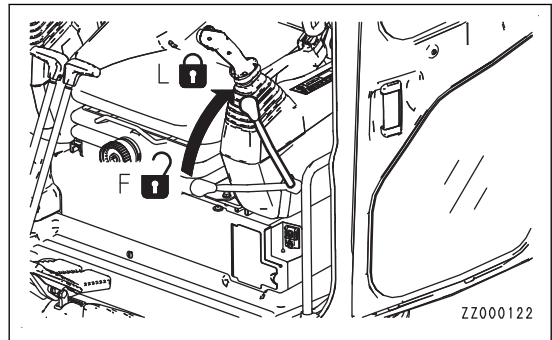

6. Remove floor mat fixing bolt (3) (2 places) to remove the floor mat.

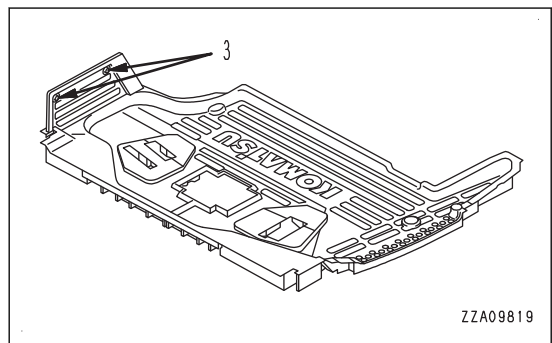

7. Remove cap (2) from water drain hole (1).
8. Flush out the dirt on the floor directly with water through water drain hole (1).
9. After completing the washing work, install cap (2) to water drain hole (1).
10. Fit the floor mat and secure it with floor mat fixing bolts (3).

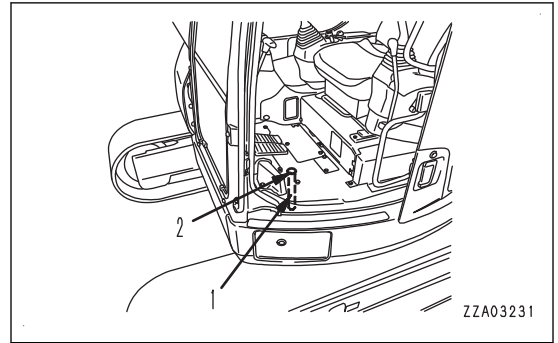

### METHOD FOR SETTING MACHINE AT ANGLE

The following methods are for tilting the machine. Select a safe method, depending on the state of the machine.

#### Use slope

### ⚠ WARNING

Select a solid and smooth slope.

Always put blocks under the track to prevent the machine from moving, and dig the work equipment into the ground.

1. Stop the machine with the work equipment on the downhill side on a slope.
2. Put blocks under the track, and thrust the edge of the blade in the ground.

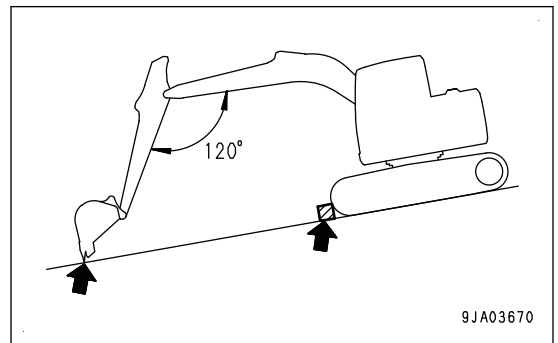

#### Use block

### ⚠ WARNING

Select a firm flat place.

Put strong blocks under the undercarriage to stabilize the machine and be extremely careful when performing the operation.

1. Raise the machine off the ground by using the boom and arm.  
When doing this, operate the levers slowly.
2. Place block (1) under the raised track to make sure that the machine is stable.

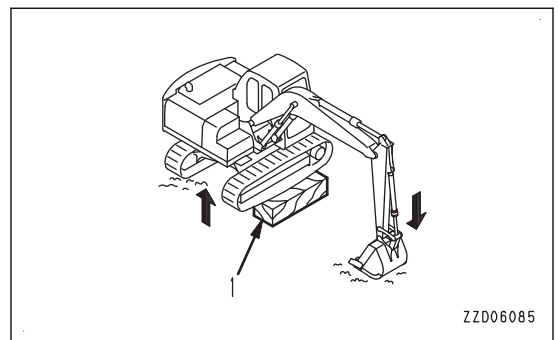



3. Raise the boom slowly and lower the machine.  
When doing this, check that the machine is always stable.

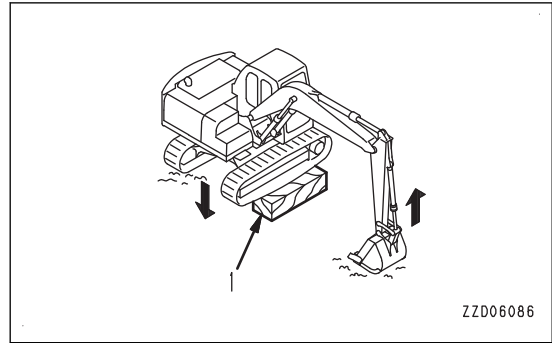

ZZD06086

**METHOD FOR CHECKING GAS SPRING**

**⚠ WARNING**

The gas spring is charged with high-pressure nitrogen gas, so improper handling may cause an explosion resulting in serious personal injury or death. When handling, always observe the following.

- Do not disassemble.
- Do not bring open flame close to it or do not dispose of it in fire.
- Do not perform drilling, welding or flame-cutting.
- Do not hit or roll it, or subject it to any impact.
- When disposing of it, the gas must be released. Ask your Komatsu distributor to have this work performed.

Gas springs are installed inside the left console (1 place), at the cab ceiling window (2 places on right and left), and inside the engine hood (1 place).

In the following cases, ask your Komatsu distributor for inspection, repair, and replacement.

- The lock lever cannot be pulled up lightly or the cab ceiling window and engine hood cannot be opened lightly.
- The lock lever does not stay at LOCK position.
- The cab ceiling window does not stay open.
- Oil or gas is found to be leaking from the gas spring.

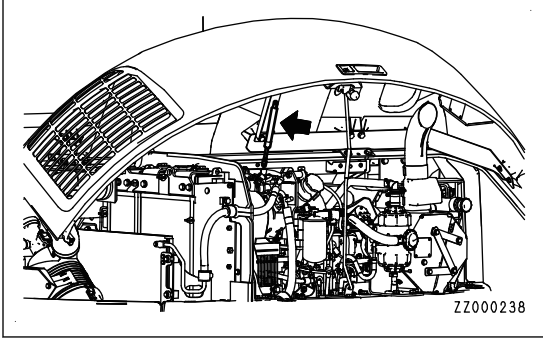
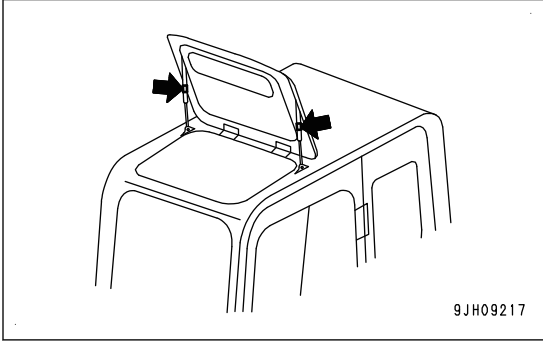

## METHOD FOR BLEEDING AIR FROM HYDRAULIC CIRCUIT

### Bleeding air from pump

Perform it when any hydraulic component or oil is replaced.

#### NOTICE

**If the pump is operated without filling the pump case with hydraulic oil, abnormal heat will be generated and this may cause a premature damage to the pump. Bleed air securely.**

1. Run the engine at low idle.
2. Open the engine hood.
3. Loosen air bleeder (1) installed to the pump and check that oil oozes out from the air bleeder.
4. After bleeding air, tighten air bleeder (1).

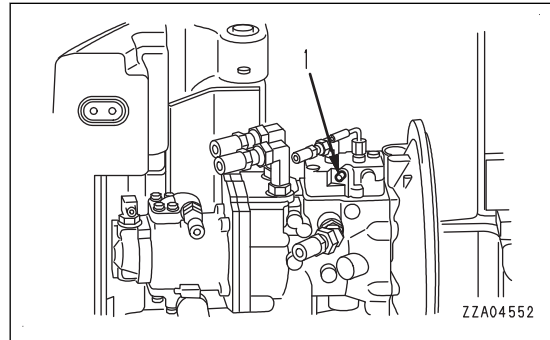

### Bleed air from between pump and hydraulic tank

Perform it when any hydraulic component or oil is replaced.

#### NOTICE

**If you run the engine at high speed without bleeding air from the piping between the pump and hydraulic tank, the pump may heat abnormally and may be broken in a short period.**

1. Start and run the engine at medium speed (1650 rpm).
2. Operate the work equipment slowly for approximately 5 minutes, and bleed air.

### Bleed air from LS circuit

Perform it only when a hose of the pump, valve, or LS circuit is replaced.

#### NOTICE

**If you do not bleed air from the LS circuit, the work equipment may malfunction.**

1. Loosen air bleeder (2) installed to the LS port of the pump.
2. Run the engine at low idle for 2 minutes.
3. Perform the bucket operation (DUMP and CURL to each stroke end) for approximately 2 minutes.
4. After bleeding air, tighten bleeder (2).

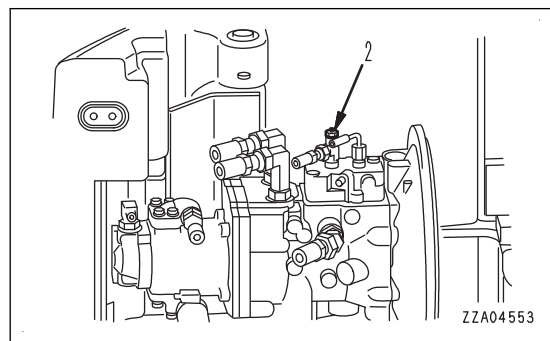

### Bleeding air from cylinders

Perform it when any hydraulic component or oil is replaced.

#### NOTICE

**If the engine is run at high speed immediately after startup or a cylinder is pushed up to its stroke end, air taken inside the cylinder may cause damage to the piston packing.**

1. Run the engine at medium speed (1650 rpm).
2. Move each cylinder to approximately 100 mm {3.9 in} before the stroke end, and repeat the operation 4 to 5 times.

Take care not to move the cylinder to the stroke end.

3. Operate each cylinder 3 to 4 times to each stroke end.
4. Operate each cylinder 4 to 5 more times to each stroke end.  
All air is bled.

### Bleeding air from swing motor

Perform it only when the oil inside the swing motor case is drained.

**NOTICE**

**If the air is not bled from the swing motor, the motor bearings may be damaged.**

1. Run the engine at low idle.
2. Loosen hose (3). When oil flows out, tighten hose (3).

**NOTICE**

**At this time, do not swing the upper structure.**

3. Run the engine at low idle and slowly swing at least 2 turns uniformly to the right and left.

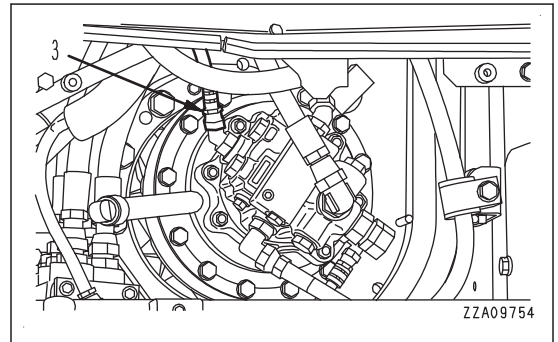

### Bleeding air from swing PPC circuit

Perform it when any hydraulic component or oil is replaced.

1. Run the engine at low idle.
2. Open the right side cover of the machine.
3. Bleed air through air bleeder (4) installed to the main valve inside the right side cover of the machine.

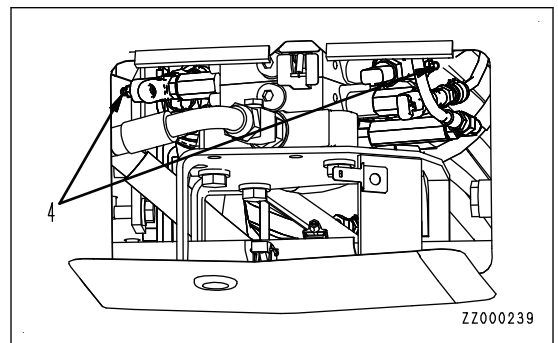

### Bleeding air from travel motor

Perform it only when the oil in the swing motor case is drained.

1. Run the engine at low idle.
2. Loosen hose (5) of port D. When oil flows out, tighten hose (5).

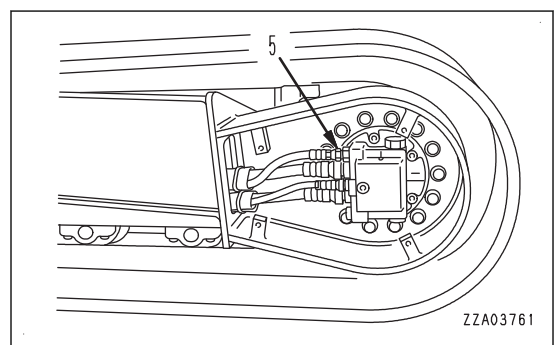

3. Run the engine at low idle and swing the upper structure 90 ° to bring the work equipment to the side of the track.
4. Push up the machine until the track is raised slightly from the ground. Perform idle rotation of track for 2 minutes. Repeat this procedure on both the right and left sides.

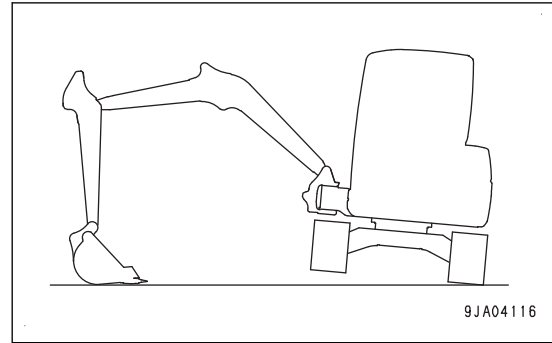

### **Bleeding air from attachment (when installed)**

Perform it when any hydraulic component or oil is replaced.

#### **NOTICE**

**If the air bleeding procedure is specified on the attachment by the manufacturer, bleed the air according to that procedure.**

If a breaker or other attachment is installed, perform the air bleeding procedure until the air is completely bled from the attachment circuit.

1. Run the engine at low idle.
2. Operate the attachment control switch repeatedly (approximately 10 times).  
Air is bled.

#### **NOTICE**

- **After completing the air bleeding operation, stop the engine, leave the machine for 5 minutes, and then start the operation. This discharges the air bubbles in the oil inside the hydraulic tank.**
- **Check for oil leakage and wipe off any spilled oil.**

## CHECKS BEFORE STARTING

For the following items, see OPERATION, "METHOD FOR CHECKING BEFORE STARTING".

- Method For Draining Water and Sediment From Fuel Tank
- Method For Checking Dust Indicator
- Method For Checking Water Separator, Draining Water and Sediment
- Method For Checking Oil Level In Hydraulic Tank, Adding Oil
- Method For Checking Coolant Level, Adding Coolant
- Method For Checking Oil Level In Engine Oil Pan, Adding Oil
- Method For Checking Electric Wiring
- Method For Checking Fuel Level, Adding Fuel
- Method For Checking Working Lamp
- Method For Checking Horn

## EVERY 100 HOURS MAINTENANCE

### METHOD FOR LUBRICATING WORK EQUIPMENT

#### NOTICE

If any unusual noise is generated from any greasing point, perform greasing regardless of the greasing interval.

Perform greasing every 10 hours for the first 50 hours operation on a new machine.

After the machine is subjected to digging work in the water, be sure to grease the wet pins.

Prepare a grease pump.

1. Set the machine to the greasing posture shown on the figure, lower the work equipment to the ground, and stop the engine.

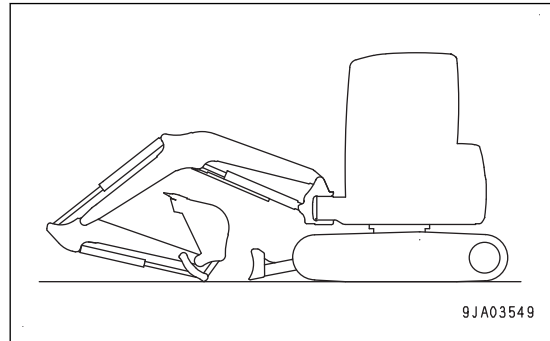

2. By using a grease pump, pump in grease through the grease fittings shown by arrows.

(1) Arm and Bucket connection pin (1 place)

3. After greasing, wipe off any old grease that is pushed out.

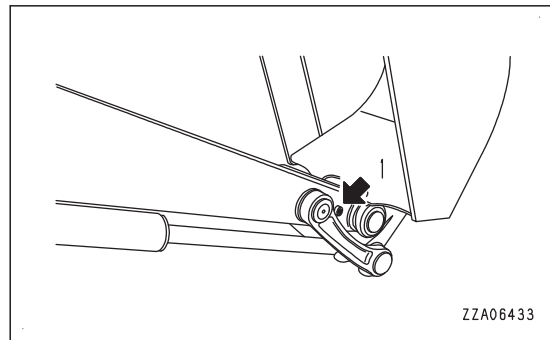

## METHOD FOR CHECKING OIL LEVEL IN SWING MACHINERY CASE, ADDING OIL

### WARNING

Immediately after the engine is stopped, its parts and oil are still very hot, and may cause burn injury. Accordingly, wait until they have cooled down before starting the work.

Prepare a container to receive oil.

1. Loosen bolt (1) and move cover (2).

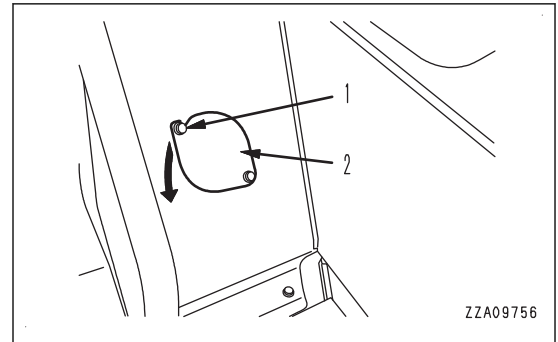

2. Pull out dipstick (G).
3. Wipe off the oil from the dipstick with a cloth.
4. Fully insert dipstick (G) into the dipstick pipe, then remove it.
5. Check the oil level with dipstick (G).  
The oil level should be between H and L marks on the dipstick.
6. If the oil level is below L mark on dipstick (G), add oil through the hole for the dipstick.
7. If the oil level is higher than H mark on dipstick (G), lower it to a proper level according to the following procedure.
  - 1) Place a container to catch oil under drain valve (P).
  - 2) Loosen drain valve (P) and drain excessive oil.
  - 3) Check the oil level again.
8. After checking oil level or adding oil, insert dipstick (G) into the hole.

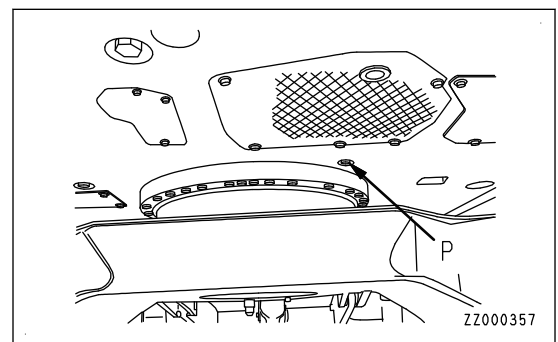
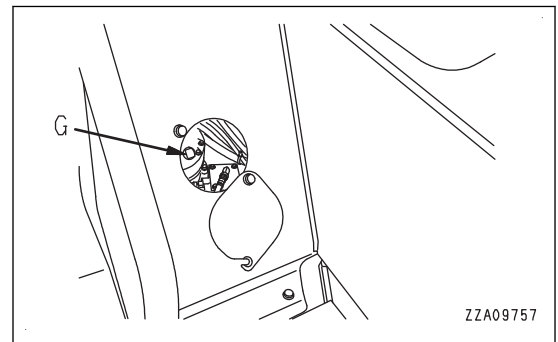



**EVERY 250 HOURS MAINTENANCE**

**METHOD FOR CHECKING OIL LEVEL IN FINAL DRIVE CASE, ADDING OIL**

**⚠ WARNING**

- Immediately after the engine is stopped, its parts and oil are still very hot and may cause burn injury. Accordingly, wait until they have cooled down before starting the work.
- If there is remaining pressure inside the case, the oil or plug may jump out. Loosen the plug slowly to release the pressure.
- Do not stand in front of the plug when you loosen the plug.

Items to be prepared

- Container to catch oil
- Hexagonal wrench

1. Bring plug (P) to the lowest position.
2. Place the container to catch oil under plug (P).
3. Remove plug (G) with the hexagonal wrench.
4. Check the oil level.

The oil level should be near the lower edge of the hole of plug (G).

5. If the oil level is low, remove plug (F) with the hexagonal wrench and add oil through the hole of plug (F).  
Add engine oil until it overflows from the hole of plug (G).
6. After checking, tighten plugs (F) and (G).

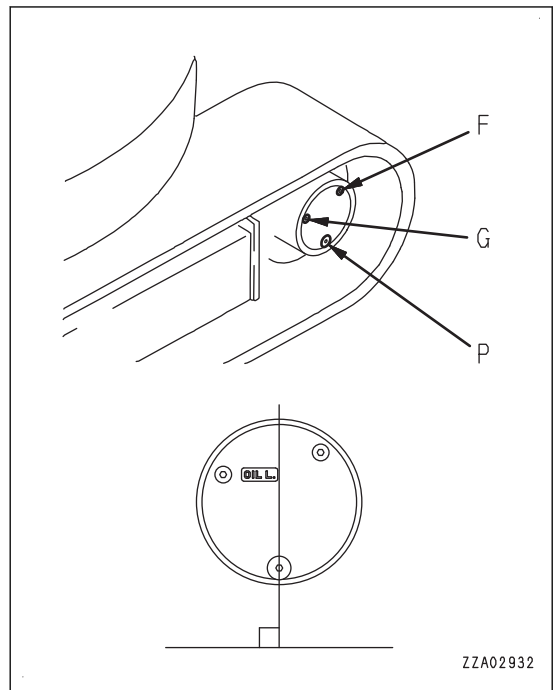

## METHOD FOR CHECKING BATTERY ELECTROLYTE LEVEL

Perform this procedure before operating the machine.

Inspect the battery electrolyte level at least once a month.

### WARNING

- Do not use the battery if the battery electrolyte level is below LOWER LEVEL line. If you do so, it will reduce the service life of the battery. In addition, it may cause an explosion.
- The battery generates flammable gas and there is a danger of explosion. Do not bring any open flame near the battery.
- Battery electrolyte is dangerous object. If it gets in your eyes or on your skin, wash it off with a large amount of water and consult a doctor.
- Do not use a dry wipe to clean the battery. A wet wipe will prevent fire or explosion from static electricity.

### NOTICE

- Do not add the electrolyte to the battery exceeding UPPER LEVEL line. If the electrolyte level is too high, it may leak and cause damage to the paint surface or corrode other parts.
- When adding purified water in cold weather, add it before starting operations in the morning to prevent the purified water from freezing.
- Install the rubber cover to prevent a fire while taking care not to roll it up.
- If the rubber cover rolls up and blocks the fuel cooler, the fuel cooler may overheat. Put the rubber cover under the fuel cooler.

### If it is possible to check electrolyte level from side of battery

If it is possible to check the electrolyte level from the side of the battery, check as follows.

1. Open the battery inspection cover.
2. Roll up rubber cover (1) installed on the top of the battery.
3. Clean around the electrolyte level line with a cloth wet with water.
4. Check that the electrolyte level is between UPPER LEVEL (U.L.) line and LOWER LEVEL (L.L.) line.

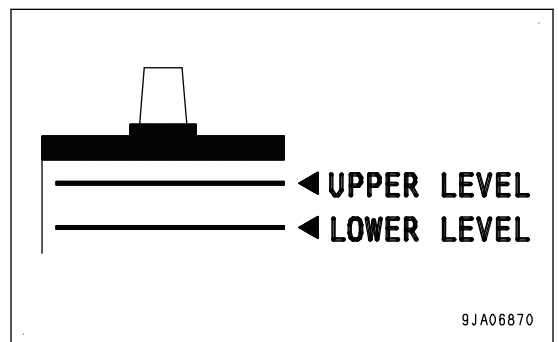
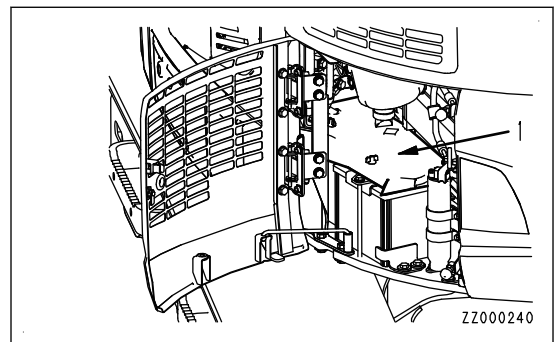

5. If the electrolyte level is below the middle between UPPER LEVEL (U.L.) and LOWER LEVEL (L.L.) lines, immediately remove cap (2) and add purified water (e.g. commercially available replenishment water for a battery) to U.L. line.
6. After adding the purified water, tighten cap (2) securely.
7. Return rubber cover (1) to its original position.

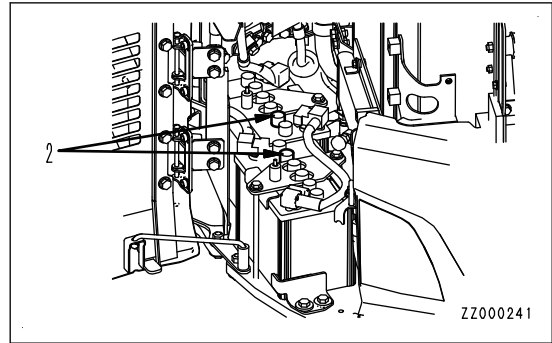

**REMARK**

If the purified water is added to above UPPER LEVEL (U.L.) line, remove the fluid by using a syringe to lower the level to UPPER LEVEL (U.L.) line. Neutralize the removed fluid with baking soda (sodium bicarbonate), then flush it away with a large amount of water. If necessary, consult your Komatsu distributor or a battery manufacturer.

**If it is impossible to check electrolyte level from side of battery**

If it is impossible to check the electrolyte level from the side of the battery, or there is no UPPER LEVEL line on the side of the battery, check according to the following procedures.

1. Open the battery inspection cover.
2. Roll up rubber cover (1) installed above the battery.

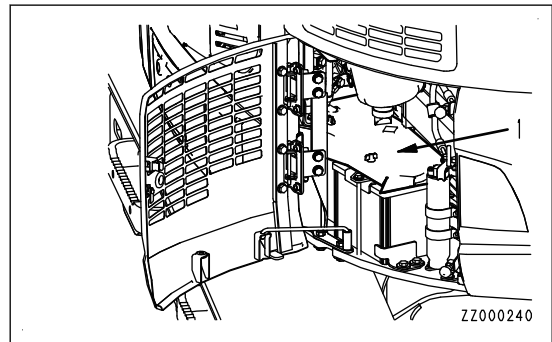

3. Remove caps (2) from the top of the battery.

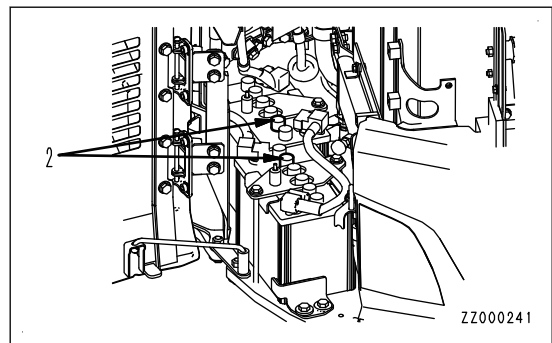

4. Look into fluid filler port (3) and check the electrolyte level.
5. If the electrolyte does not reach the sleeve (4), always add the purified water (e.g. commercially available replenishment water for a battery) so that the level reaches the bottom of the sleeve (UPPER LEVEL line).

**(A) Suitable level**

Electrolyte level is up to bottom of sleeve, so surface tension causes electrolyte surface to bulge and poles appear bent.

**(B) Low level**

Electrolyte level is not up to bottom of sleeve, so poles appear straight and not bent.

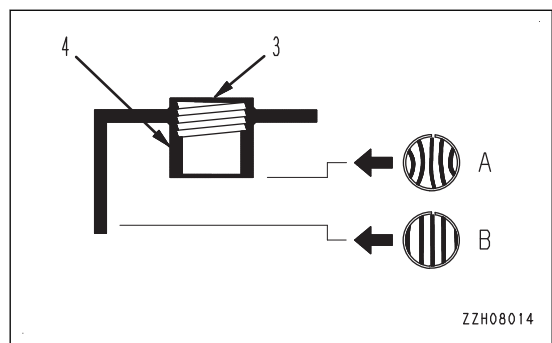

6. After adding the purified water, tighten cap (2) securely.

7. Return rubber cover (1) to its original position.

**REMARK**

If purified water is added to above the bottom tip of the sleeve, use a syringe to remove electrolyte. Neutralize the removed fluid with baking soda (sodium bicarbonate), then flush it away with a large amount of water. If necessary, consult your Komatsu distributor or your battery manufacturer.

**If it is possible to use indicator to check electrolyte level**

If it is possible to use an indicator to check the electrolyte level, follow the instructions given.

## METHOD FOR CHECKING AND ADJUSTING AIR CONDITIONER COMPRESSOR BELT TENSION

### Check air conditioner compressor belt tension

1. Open engine hood (1).
2. Securely lock the hood with hood support lever (2).

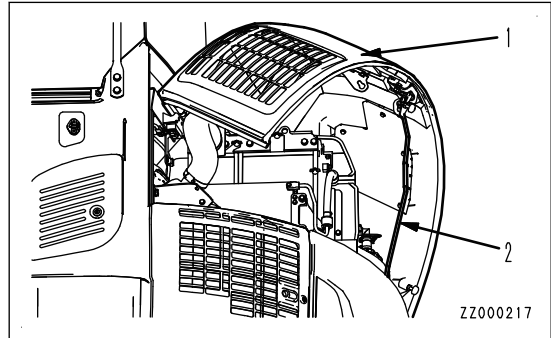

3. Remove bolt (3) of the fan guard.
4. Loosen bolt (4) and move the fan guard in the arrow direction.

Do not remove clamp mounting bolt (5) of the air conditioner hose.

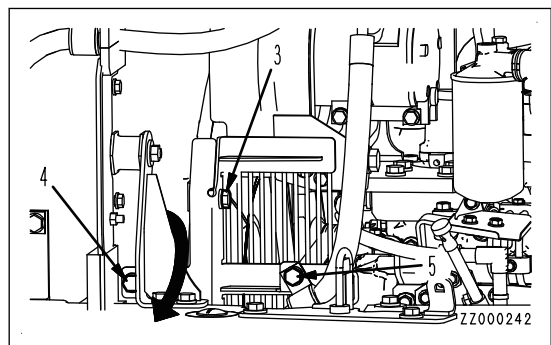

5. Press the middle point between compressor pulley (6) and fan pulley (7) with your finger (approximately 58.8 N {6.0 kg} ).

If deflection (a) is 6 to 9 mm {0.236 to 0.354 in} , the belt tension is normal.

If the deflection is out of the standard range, adjust it into the standard range.

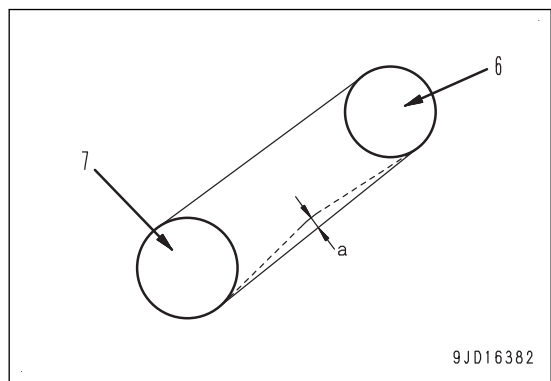

### Adjust air conditioner compressor belt tension

Prepare a bar.

1. Put the bar between fixing bracket (8) and compressor mounting bracket (9) and fix compressor mounting bracket (9).
2. Loosen bolts (10) and (11).

When the bolts (10) and (11) are loosened, compressor mounting bracket (9) can move around the mounting position of bolt (10).

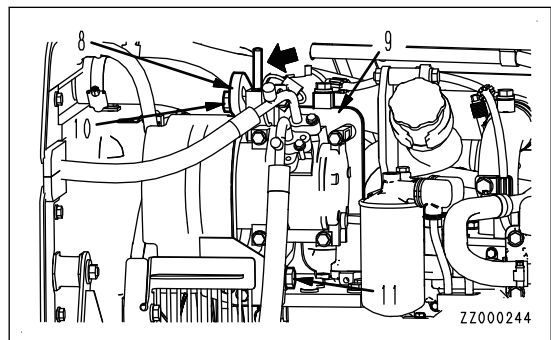

3. Press the middle point between compressor pulley (6) and fan pulley (7) with your finger (approximately 58.8 N {6.0 kg} ).  
If deflection (a) is 6 to 9 mm {0.236 to 0.354 in} , the belt tension is normal.
4. When the compressor is positioned, fix it by tightening bolts (10) and (11).
5. Check again if the belt tension is appropriate.  
Adjust it again if it is not within the proper range.
6. Check each pulley for breakage and wear of the V-groove and check the V-belts for wear.  
In particular, check carefully that the V-belt is not in contact with the V-groove bottom.
7. Replace the belt with a new one if the belt is stretched and has no allowance for adjustment, or has slipping sound or squeak because of cuts or cracks of the belt.  
Ask your Komatsu distributor for replacement of the belt.

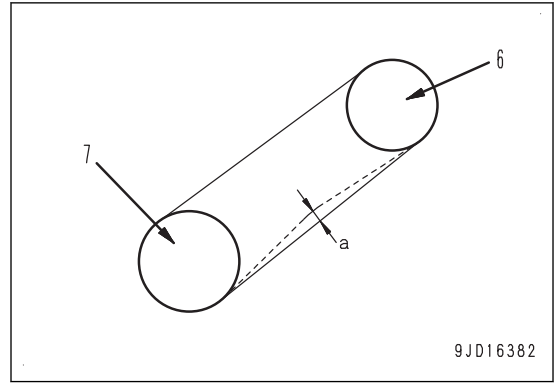

### EVERY 500 HOURS MAINTENANCE

Maintenance for every 100 and 250 hours should be performed at the same time.

### METHOD FOR LUBRICATING

#### NOTICE

- If any unusual noise is generated from any greasing point, perform greasing regardless of the greasing interval.
- Perform greasing every 10 hours for the first 50 hours of operation on a new machine.
- After the machine is subjected to digging work in the water, be sure to grease the wet pins.

Prepare a grease pump.

1. Set the machine to the greasing posture shown on the figure, lower the work equipment to the ground, and stop the engine.

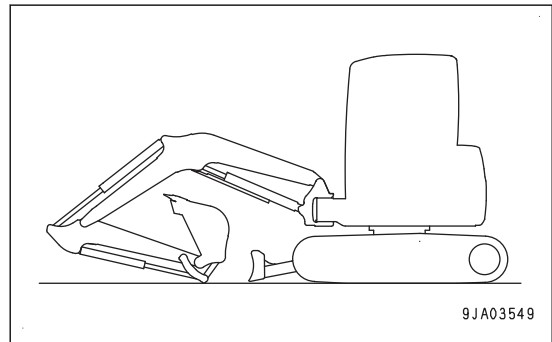

2. By using a grease pump, pump in grease through the grease fittings shown by arrows.

- (1) Boom foot pin (2 places)
- (2) Boom cylinder foot pin (1 place)

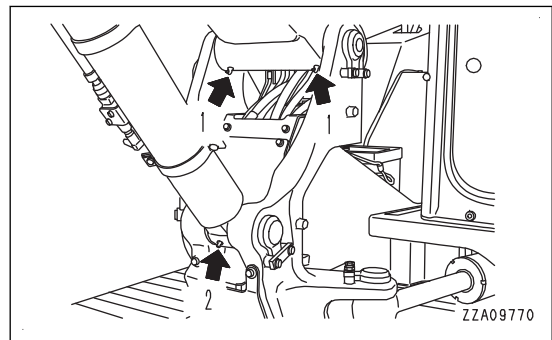

- (3) Boom cylinder rod end pin (1 place)
- (4) Arm cylinder foot pin (2 place)
- (5) Arm cylinder rod end (1 place)
- (6) Boom and arm connection pin (1 place)
- (7) Bucket cylinder foot pin (1 place)
- (8) Arm-Link connection pin (1 place)

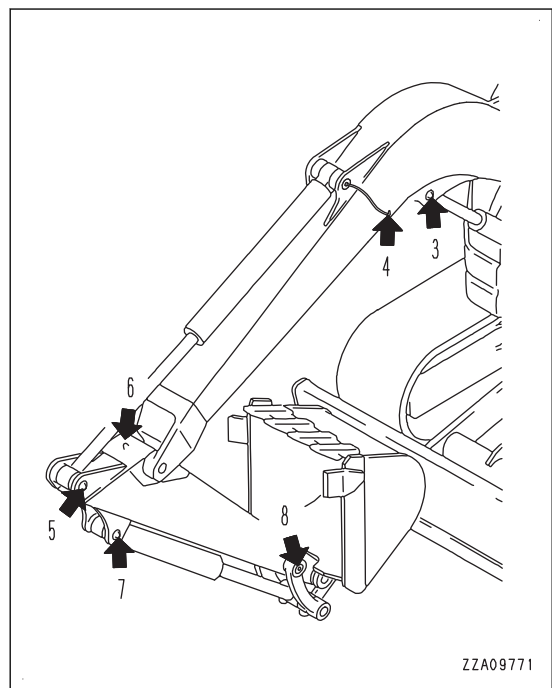

- (9) Link connection pin (2 places)
- (10) Bucket cylinder rod end pin (1 place)
- (11) Bucket and Link connection pin (2 place)

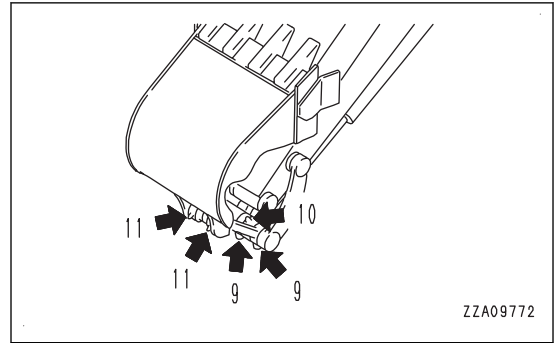

- (12) boom swing bracket pin (2 places)
- Supply grease to the boom swing bracket pin according to the following procedure.

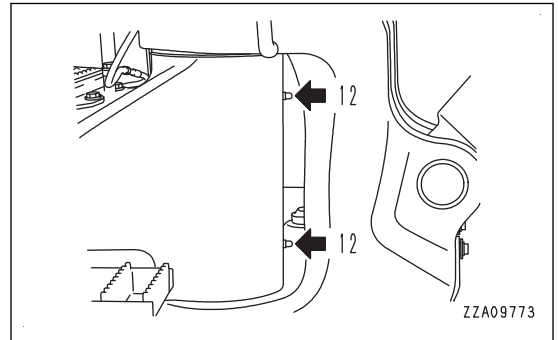

- 1) Set the boom to the swing neutral position and supply grease to the pin.

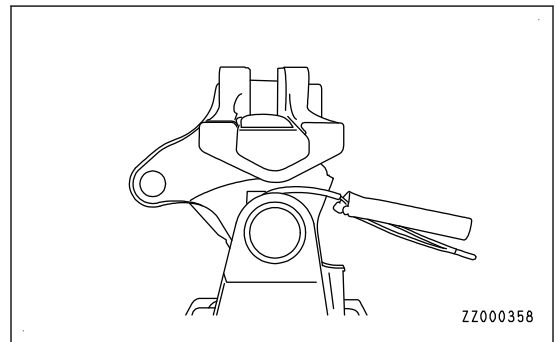

- 2) Swing the boom to the left stroke end and supply grease to the pin.

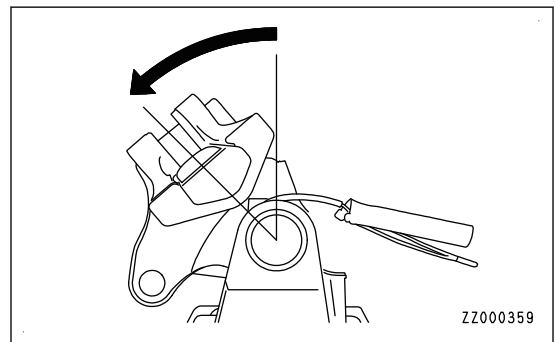

- 3) Swing the boom to the right and left several times.

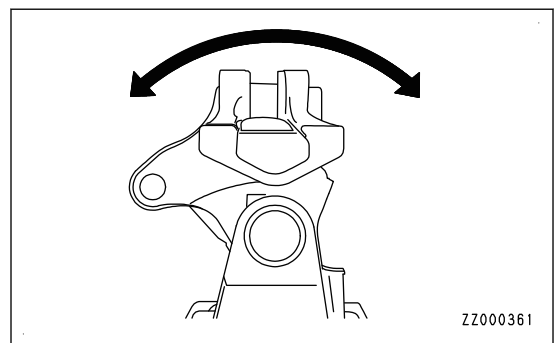



- (13) Boom swing cylinder rod end pin (1 place)
- (14) Boom swing cylinder foot pin (1 place)

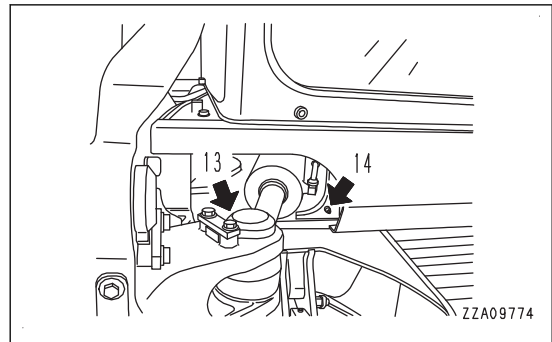

- (15) Blade cylinder foot pin (1 place)
- (16) Blade cylinder rod end (1 place)
- (17) Blade foot pin (2 places)

3. After greasing, wipe off any old grease that is pushed out.

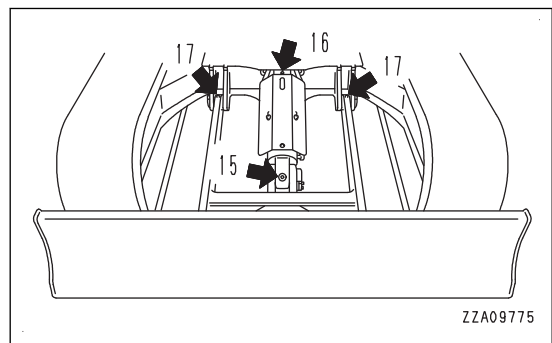

# METHOD FOR CHANGING OIL IN ENGINE OIL PAN, REPLACING ENGINE OIL FILTER CARTRIDGE

## ⚠ WARNING

Immediately after the engine is stopped, its parts and oil are still very hot, and may cause burn injury. Accordingly, wait until they have cooled down before starting the work.

Refill capacity of oil pan: 11.5 l {3.04 U.S.Gal}

Items to be prepared

- Filter wrench
  - Container to catch oil
1. Remove undercover (1) at the bottom of the machine.
  2. Place the oil container to catch oil under drain plug (P).
  3. Loosen drain plug (P) to drain oil. Do it slowly so that you do not get splashed with drained oil.
  4. Tighten drain plug (P).

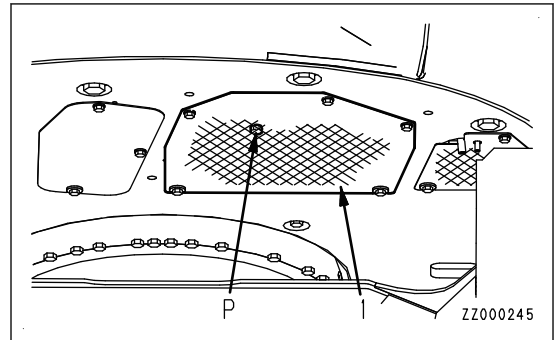

5. Open engine hood (2).
6. Securely lock the hood with hood support lever (3).

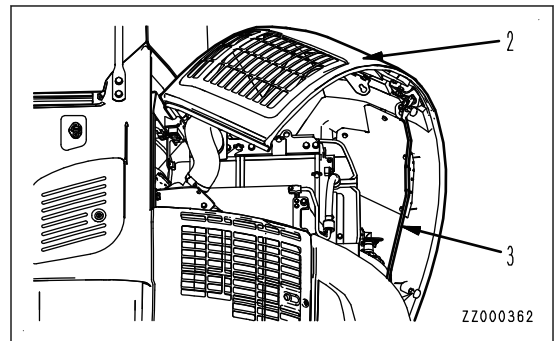

7. Turn filter cartridge (4) counterclockwise by using the filter wrench, and remove it.
8. Clean the filter head.

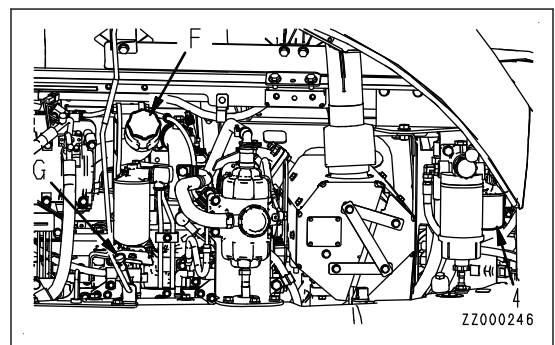

**REMARK**

Check that there is no old packing stuck to the filter holder. If there is any old packing stuck to the filter, it will cause leakage of oil.

9. When installing the new filter cartridge, apply clean engine oil (or grease) to its packing and thread portion.

When installing the cartridge, tighten it until the packing surface contacts the seal surface of the filter holder, then tighten it 1/2 or more turns.

10. After replacing the filter cartridge, refill with engine oil through oil filler port (F) until the oil level is between the H and L marks on dipstick (G).
11. Run the engine at low idle for a while and then stop it.
12. Check the oil level in the engine oil pan.  
Check that the oil level is between H and L marks on the dipstick.  
For the oil level check procedure, see "METHOD FOR CHECKING OIL LEVEL IN ENGINE OIL PAN, ADDING OIL".
13. Install undercover (1).

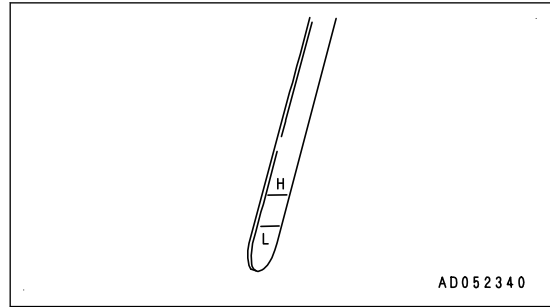

**METHOD FOR REPLACING FUEL PREFILTER CARTRIDGE**

**⚠ WARNING**

- Immediately after the engine is stopped, all parts are still very hot, so do not replace the filter immediately. Wait until all of parts cool down before starting the work.
- High pressure is generated inside the engine fuel piping system when the engine is running. When replacing the filter, wait for at least 30 seconds after stopping the engine to let the internal pressure go down before replacing the filter.
- Do not bring any open flame close.

**NOTICE**

- Komatsu genuine fuel filter cartridges use a special filter that has highly efficient filtering ability. When replacing parts, Komatsu recommends using Komatsu genuine parts.
- The common rail fuel injection system used on this machine consists of more precise parts than those in the conventional injection pump and nozzles. If any cartridge other than a Komatsu genuine filter cartridge is used, dust or dirt may get in and cause problems with the injection system. Never use a substitute.
- When performing inspection and maintenance of the fuel system, be careful not to let any dirt or dust get in, more than ever before. If dust sticks to the fuel system, wash it off thoroughly with fuel.

Items to be prepared

- Filter wrench
- Container to catch fuel

1. Open inspection cover (1).

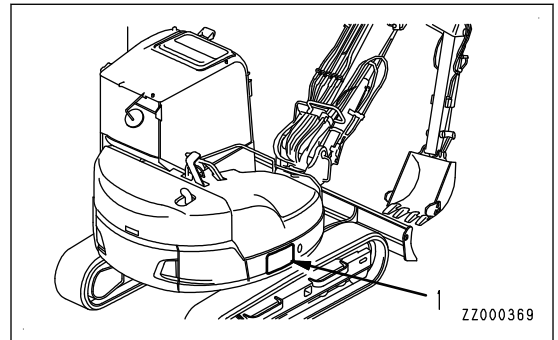

2. Turn valve (2) to CLOSE position (S).

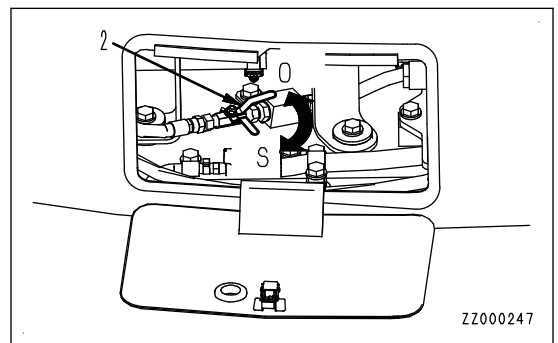

- 3. Open engine hood (3).
- 4. Securely lock the hood with hood support lever (4).

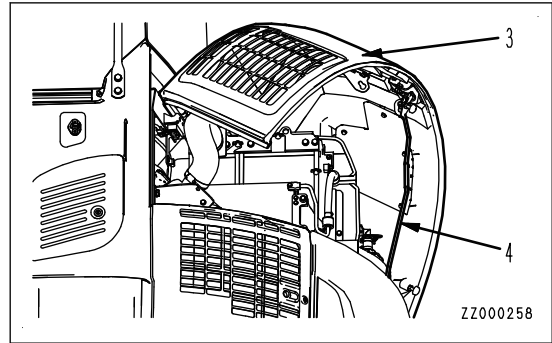

- 5. Place a container under the fuel prefilter cartridge to receive the fuel.
- 6. Loosen drain valve (5) and drain water and sediments from transparent cup (6), and also drain all the fuel from filter cartridge (7).
- 7. Turn transparent cup (6) counterclockwise to remove it by using the filter wrench. This cup is used again.
- 8. Turn filter cartridge (7) counterclockwise by using the filter wrench, and remove it.

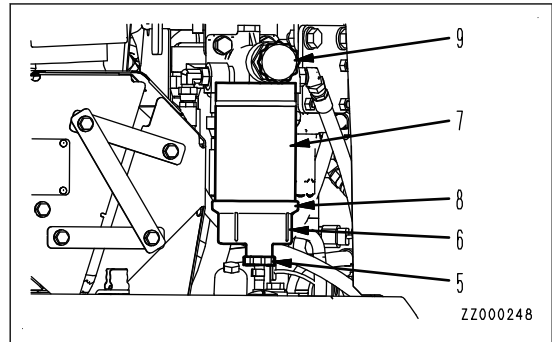

- 9. Install currently removed transparent cup (6) to the bottom of the new filter cartridge. At this time, be sure to replace O-ring (8) with a new one.

When installing the transparent cup, thinly apply oil to the packing surface, contact it to the sealing surface of filter cartridge (7), and then tighten it 1/4 to 1/2 turn.

If the transparent cup is fastened too much, the O-ring will be damaged and this leads to leakage of fuel. If it is too loose, fuel will also leak from gaps of the O-ring. Therefore, be sure to observe the fastening angle.

- 10. Clean the filter head.
- 11. Fill the new filter cartridge with clean fuel, thinly apply oil to the packing surface, then install it to the filter head.

**NOTICE**

- When filling the filter cartridge with fuel, do not remove cap (B). Always fill with fuel from 8 small holes (A) on the dirty side.
- After filling with fuel, remove cap (B) and install the fuel filter.
- Always fill with clean fuel. Be careful not to let any dirt or dust get into the fuel. In particular, center portion is the clean side, so do not remove cap (B) when filling with fuel. Be careful not to let dirt or dust get into the center portion on the clean side.

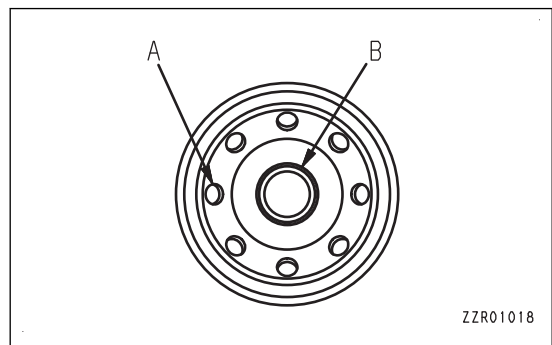

When installing the cartridge, tighten it until the packing surface contacts the seal surface of the filter holder, then tighten it 3/4 of a turn.

If the filter cartridge is fastened too much, the packing will be damaged and this leads to leakage of fuel. If the filter cartridge is too loose, fuel will also leak from the packing. Therefore, be sure to observe the fastening angle.

When tightening with a filter wrench, be extremely careful not to dent or damage the filter.

- 12. Check that drain valve (5) is closed securely.
- 13. Turn valve (2) to OPEN position (O).
- 14. After completing the replacement of filter cartridge (7), bleed air according to the following procedure.
  - 1) Fill up the fuel tank with fuel (to the level where the float is at the highest position).

- 2) Loosen the knob of feed pump (9), pull it out, then pump it in and out until the movement becomes heavy.

**REMARK**

- It is not necessary to remove the plugs at the fuel prefilter head and at the fuel main filter head.
- When the engine runs out of fuel, use the same procedure to operate feed pump (9) and bleed the air.

15. After bleeding air, push in the knob of feed pump (9) and tighten it.
16. After replacing filter cartridge (7), start and run the engine at low idle for 10 minutes.
17. Check for leakage of oil from the filter seal surface and transparent cup mounting face.

If the leakage is noticed, check the filter cartridge for its tightening condition.

If there is still fuel leakage, repeat steps 2 to 8 to remove the filter cartridge, and if any damage or pinched foreign material on the packing surface is found, replace it with a new cartridge and repeat steps 9 to 16 to install it.

**METHOD FOR CHECKING SWING PINION GREASE LEVEL, ADD GREASE**

1. Remove bolts (1) (6 pieces) and to remove cover (2).

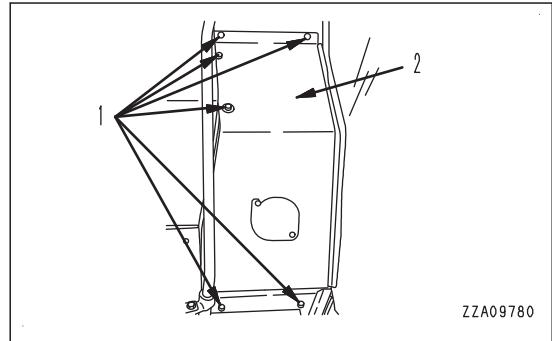

2. Remove bolts (3) (2 pieces) on the top of the revolving frame to remove grease filler port cover (4).
3. Check that grease is filled.
4. Check that the grease is not milky white.  
Total amount of grease: 5.5 ℓ (1.45 U.S.Gal)  
If the grease is milky white, it needs to be replaced. Ask your Komatsu distributor to replace it.
5. Install grease filler port cover (4) with bolts (3).
6. Install cover (2) with bolt (1).

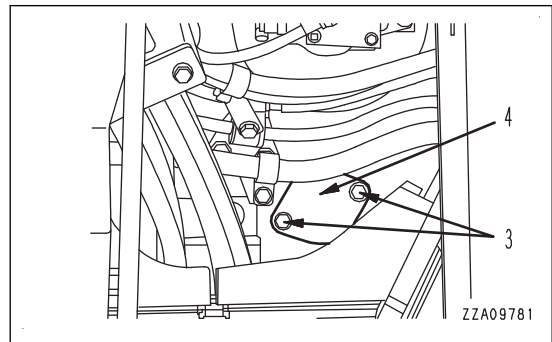

**METHOD FOR LUBRICATING SWING CIRCLE**

Prepare a grease pump.

1. Lower the work equipment to the ground.

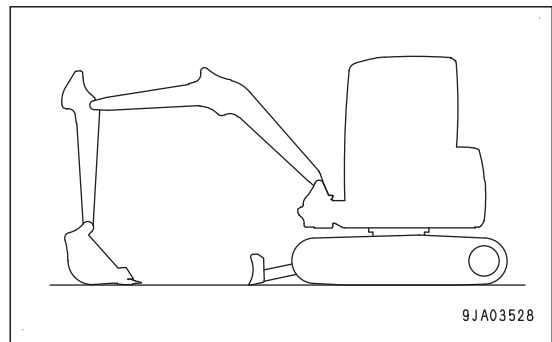

2. By using a grease pump, apply grease to the grease fittings marked by arrows (2 places).
3. After greasing, wipe off any old grease that is pushed out.

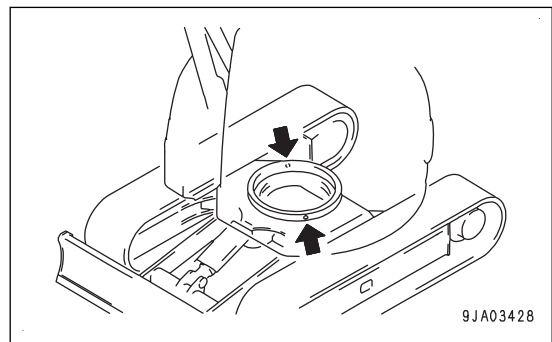

**METHOD FOR CHECKING AND CLEANING RADIATOR FINS, OIL COOLER FINS, AFTERCOOLER FINS, FUEL COOLER FINS, AND AIR CONDITIONER CONDENSER FINS**

**⚠ WARNING**

If compressed air, high-pressure water, or steam hits your body directly or dirt is scattered by the compressed air, high-pressure water, or steam, there is a danger of personal injury. Always wear personal protective items such as protective eyeglasses and dust mask.

**NOTICE**

- When using compressed air for cleaning, blow it keeping some distance as perpendicular to the core as possible to avoid damaging the fins. Damage on the fins can cause water leakage and overheating.
- In a dusty job site, check the fins every day, regardless of the maintenance interval.

1. Open engine hood (1).
2. Securely lock the hood with hood support lever (2).
3. Open battery inspection cover (3) on the left side of the machine.
4. Securely lock the cover with cover support lever (4).

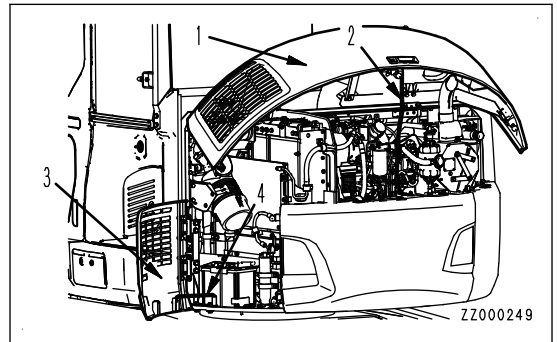

5. Remove wing screws (5) (4 pieces) and remove net (6).
6. Clean net (6).

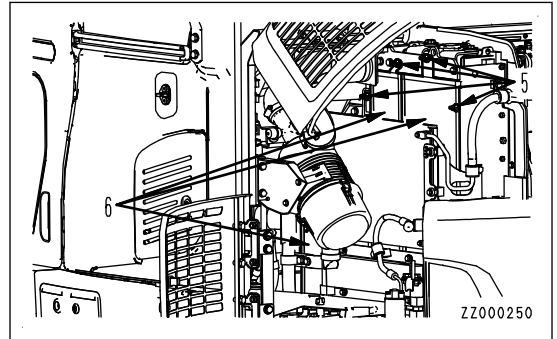

7. Check the front and rear surfaces of oil cooler fins (7), radiator fins (8), aftercooler fins (9), air conditioner condenser fins (10), and fuel cooler fins (11). If there is any mud, dirt, or leaves stuck to the fins, blow it off with compressed air.

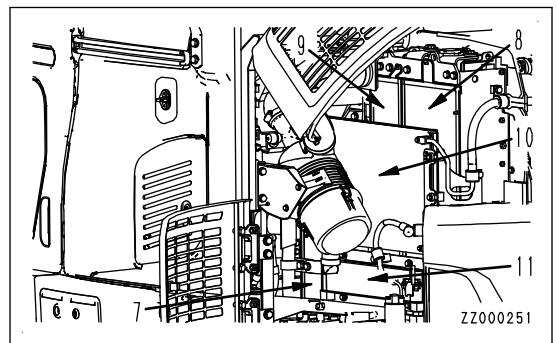

**NOTICE**

Steam or water may be used instead of the compressed air. However, when performing powerful steam cleaning (high-pressure machine wash) of the heat exchange equipment (radiator, oil cooler, aftercooler, fuel cooler, air conditioner condenser), maintain sufficient distance from the machine when performing the work. If steam cleaning (high-pressure machine wash) is performed at close distance, there is a danger that the internal fins of the heat exchange equipment may be deformed, and this will cause early clogging and breakage of the equipment.



8. Remove clamp mounting bolt (12) of the air conditioner hose.
9. Remove condenser mounting bolts (13) (2 places) on the counterweight side.
10. Loosen condenser mounting bolts (14) (2 places) on the cab side.
11. Spread and clean the condenser.

**NOTICE**

**At this time, take care that forces are not applied to the tube part of the air conditioner hoses.**

**If any tube part is broken, the refrigerant is released and the air conditioner does not work.**

12. Check the rubber hoses and check the hose clamps for looseness.  
If the rubber hoses are cracked or fragile, replace them.  
If the hose clamps are loosened, tighten them.
13. After inspecting and cleaning, install net (6) as it was.

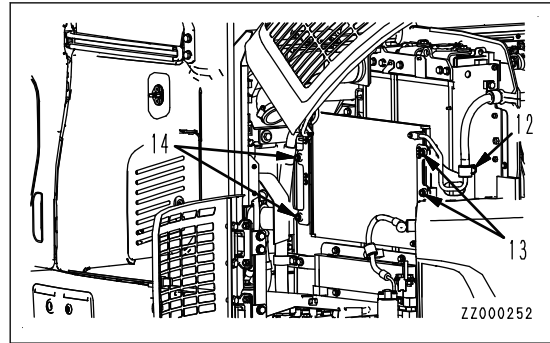

**METHOD FOR CLEANING AIR CONDITIONER FRESH/RECIRC AIR FILTERS**

**⚠ WARNING**

- When using compressed air, there is a danger that dirt may scatter and cause personal injury. Always wear personal protective items such as protective eyeglasses and dust mask.
- Always check that the slide door is locked at the open or closed position before cleaning FRESH or RECIRC air filter. If the slide door is free, there is a danger that it may suddenly move and catch your fingers or break the cover.

**NOTICE**

- As a guideline, the filters should be cleaned every 500 hours, but on dusty jobsites, clean the filters more frequently.
- When washing the floor, take care not to splash water over the filter.

**Clean recirculation air filter**

1. Open cover (1) at the front bottom left of the operator's seat.
2. Take out recirculation air filter (2).
3. Clean filter (2) with compressed air.

If there is oil on the filter, or if the filter is extremely dirty, wash it in a neutral detergent. After rinsing it in water, dry it thoroughly before using it again.

Replace the filter with a new one every year. If the clogging of the filter cannot be removed by blowing with air or washing in water, replace the filter immediately.

4. Return cleaned recirculation air filter (2) and close cover (1).

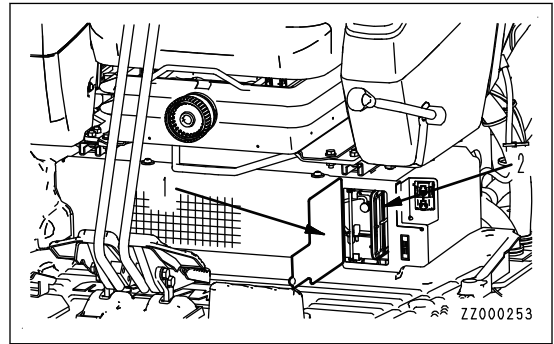

**Clean fresh air filter**

1. Unlock cover (1) at the rear left of the operator's cab with the starting switch key.

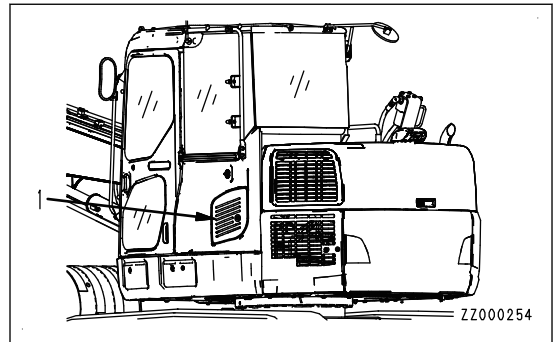

2. Open cover (1) with the hand.
3. Fix the cover with cover support lever (3).
4. Remove filter (2).
5. Clean filter (2) with compressed air.

If there is oil on the filter, or if the filter is extremely dirty, wash it in a neutral detergent. After rinsing it in water, dry it thoroughly before using it again.

Replace the filter with a new one every year. If the clogging of the filter cannot be removed by blowing with air or washing in water, replace the filter immediately.

6. Return filter (2).

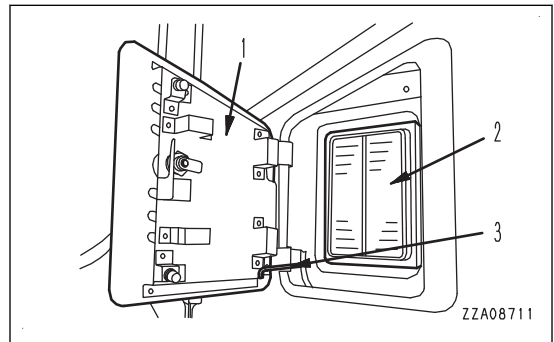

**REMARK**

The fresh air filter must be installed facing it in the correct direction.

When installing, insert the long (L) end of filter (2) into the filter case first. If the short (S) end is installed first, cover (1) will not close.

- 7. Release cover support lever (3).
- 8. Close cover (2).
- 9. Lock with the starting switch key.

Do not forget to remove the starting switch key after locking.

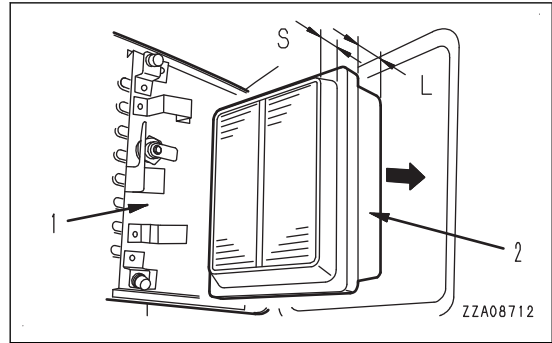

**METHOD FOR REPLACING HYDRAULIC TANK BREATHER ELEMENT**

**⚠ WARNING**

- Immediately after the engine is stopped, its parts and oil are still very hot and may cause burn injury. Wait for the temperature to go down, and start the work.
- When removing the oil filler cap, the oil may spout out. Turn it slowly to release the internal pressure, then remove it.

- 1. Open dirt cover (1).
- 2. Lock securely with cover support lever (2).
- 3. Loosen bolt (3) and remove plate (4) on the top of oil filler port (F).
- 4. Remove the cap of oil filler port (F) gradually to release the internal pressure.
- 5. Remove the cap of oil filler port (F).

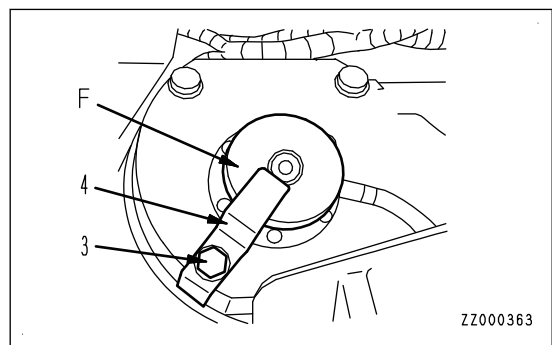
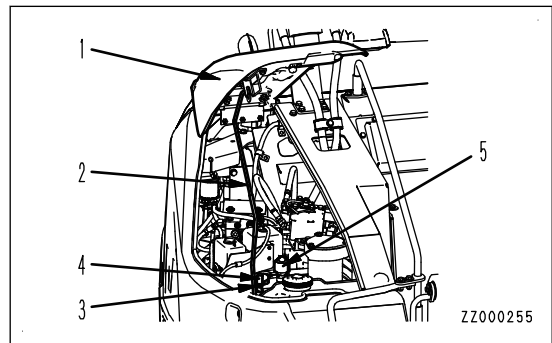

- 6. Remove nut (6) of breather (5), and then remove cover (7).
- 7. Replace filter element (8) with a new one.
- 8. Install cover (7) and nut (6).

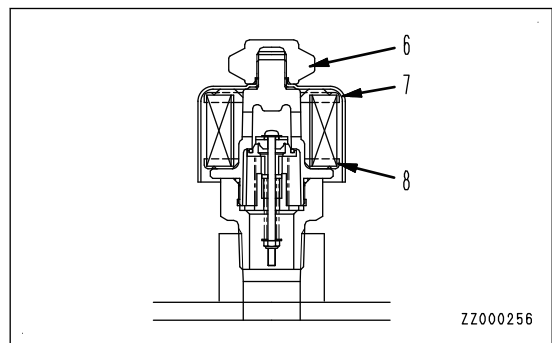

## EVERY 1000 HOURS MAINTENANCE

Maintenance for every 100, 250 and 500 hours should be performed at the same time.

### METHOD FOR REPLACING HYDRAULIC OIL FILTER ELEMENT

#### WARNING

Immediately after the engine is stopped, its parts and oil are still very hot and may cause burn injury. Wait for the temperature to go down, and start the work.

When removing the oil filler cap, the oil may spout out. Turn it slowly to release the internal pressure, then remove it.

#### NOTICE

If the machine is equipped with a hydraulic breaker, the hydraulic oil deteriorates faster than in the normal bucket digging operation. Accordingly, perform maintenance referring to “MAINTENANCE INTERVAL FOR HYDRAULIC BREAKER”.

1. Retract the arm and bucket cylinder rods, then lower the boom to lower the tooth to the ground.
2. Lower the blade.

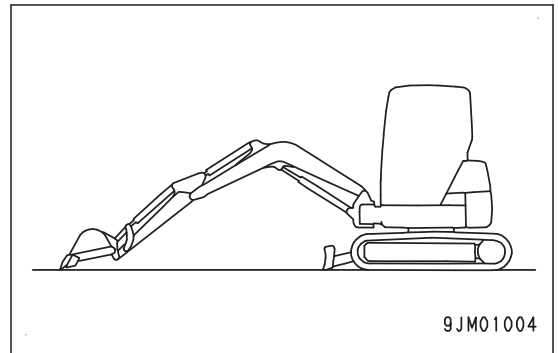

3. Set the lock lever to LOCK position (L).
4. Stop the engine.

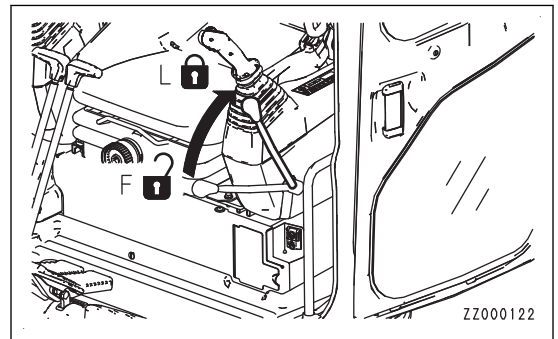

- 5. Open dirt cover (1).
- 6. Lock securely with cover support lever (2).
- 7. Loosen bolt (3) and remove plate (4) on the top of oil filler port (F).
- 8. Remove the cap of oil filler port (F) gradually to release the internal pressure.
- 9. Remove the cap of oil filler port (F).

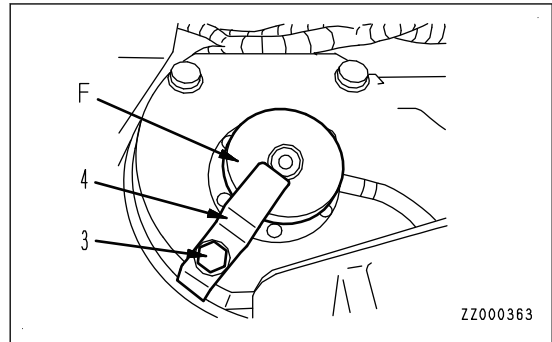
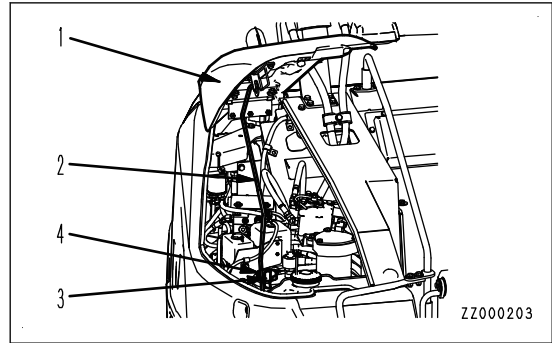

- 10. Loosen bolts (3 pieces) and remove cover (5).  
Cover (5) may jump out under the force of spring (6), so hold cover (5) down when removing the bolts.
- 11. After removing spring (6) and valve (7), take out element (8).
- 12. Clean the removed parts by using cleaning oil.
- 13. Install the new element in the place where old element (8) was installed.
- 14. Check the O-ring to be set between the hydraulic tank and cover (5).  
If the O-ring is damaged, replace it.
- 15. Place valve (7) and spring (6) onto the element.
- 16. Set cover (5) in position and install it with the bolts while pressing it down with the hand.
- 17. Install the cap of oil filler port (F).
- 18. Install plate (5) to the top of oil filler port (F) and fix it with bolt (3).
- 19. Remove cover support lever (2) and fix it to the lever lock securely.

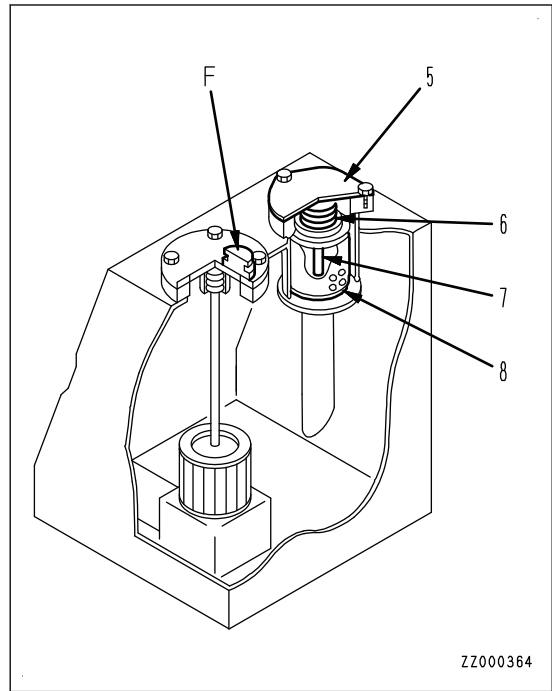

- 20. Close dirt cover (1).
- 21. Start the engine and run it at low idle for 10 minutes to bleed air.
- 22. Stop the engine.

**REMARK**

Leave the engine stopped for at least 5 minutes, and then start it. This will remove the air bubbles in the oil inside the tank.

- 23. Check that there is no leakage of oil and wipe off any oil that is spilled.

**METHOD FOR CHANGE OIL IN SWING MACHINERY CASE**

**⚠ WARNING**

**Immediately after the engine is stopped, its parts and oil are still very hot, and may cause burn injury. Accordingly, wait until they have cooled down before starting the work.**

Refill capacity: 2.8 ℓ {0.74 U.S.Gal}

Prepare a container to receive oil.

1. Swing the upper structure so that drain plug (P) on the underside of the machine is in the middle between the right and left tracks.
2. Place the oil container to catch oil under drain plug (P).
3. Remove drain plug (P), drain the oil, then tighten the plug again.

Tightening drain plug (P) to 44 to 93 Nm {4.5 to 9.5 kgm, 32.5 to 68.7 lbf}.

4. Loosen bolt (1) and move cover (2).

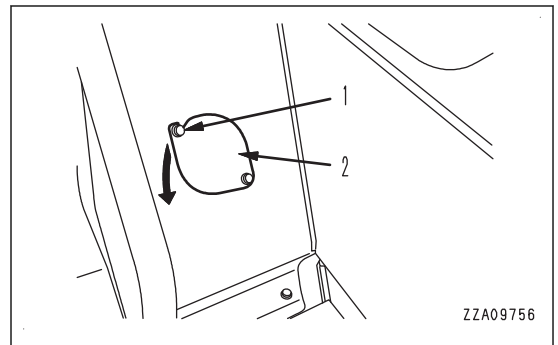
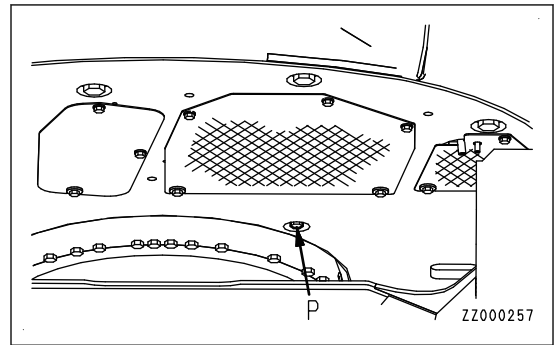

5. Add engine oil through the pipe for dipstick (G) by the refill capacity.
6. Check the oil level in the swing machinery case.

Check that the oil level is between H and L of dipstick (G).  
For the oil level check procedure, see "METHOD FOR CHECKING OIL LEVEL IN SWING MACHINERY CASE, ADDING OIL".

7. Return cover (2) to its original position and fix it with bolt (1).

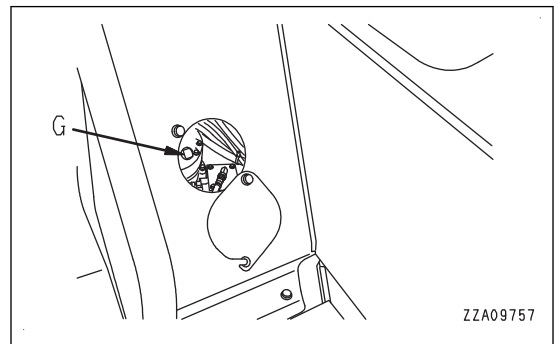

**METHOD FOR CHANGING OIL IN FINAL DRIVE CASE**

**⚠ WARNING**

- Immediately after the engine is stopped, its parts and oil are still very hot and may cause burn injury. Accordingly, wait until they have cooled down before starting the work.
- If there is remaining pressure inside the case, the oil or plug may jump out. Loosen the plug slowly to release the pressure.
- Do not stand in front of the plug when you loosen the plug.

Refill capacity (each of right and left): 1.1 ℓ {0.29 U.S.Gal}

Items to be prepared

- Container to catch oil
- Hexagonal wrench

1. Bring plug (P) to the lowest position.
2. Place the oil container to catch oil under plug (P).
3. By using a hexagonal wrench, remove plugs (P), (G), and (F) , and drain the oil.
4. Tighten plug (P) .
5. Add the refill capacity of engine oil through oil filler port (F).
6. When oil begins to overflow from plug (G) hole, install plugs (G) and (F).

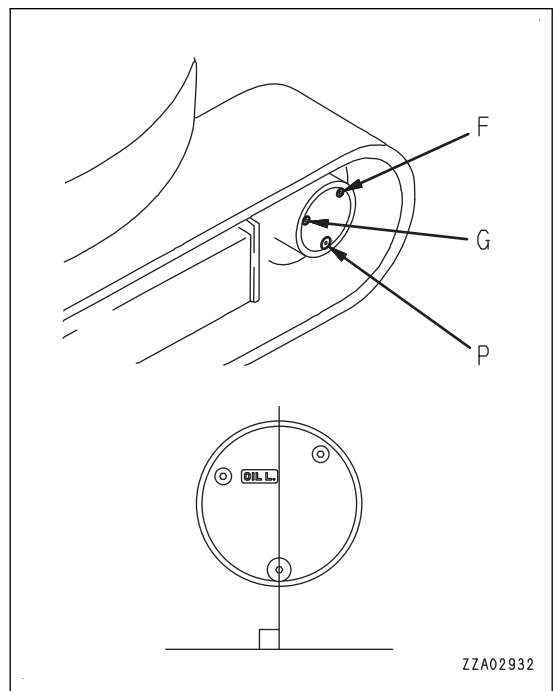

**METHOD FOR CHECKING OIL LEVEL IN PTO GEAR CASE, ADDING OIL**

**⚠ WARNING**

Immediately after the engine is stopped, its parts and oil are still very hot, and may cause burn injury. Accordingly, wait until they have cooled down before starting the work.

1. Swing the upper structure so that PTO gear case is at the center between the right and left tracks.
2. Set the lock lever to LOCK position (L).
3. Stop the engine.

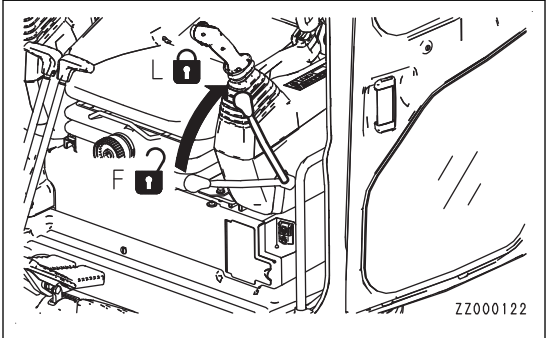

4. Remove undercover (1) at the bottom of the machine.

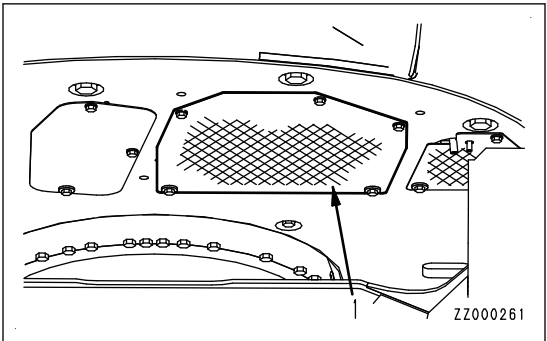

5. Remove oil level check plug (G) and check the oil level.  
If the oil level is near the lower edge of the hole of plug (P), the oil amount is proper.

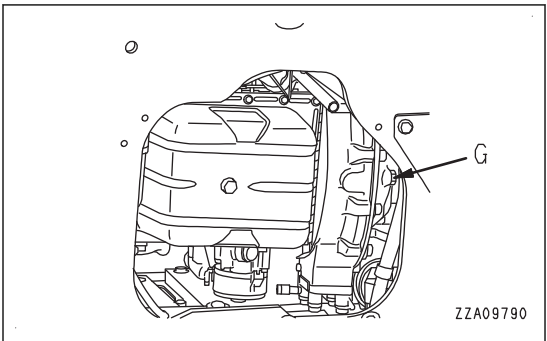

6. If the oil level is low, open the engine hood, remove the plug of oil filler port (F), and add oil.  
Add oil to near the bottom rim of the hole of oil level check plug (G).
7. Install oil level check plug (G) and the plug of oil filler port (F).
8. Install cover (1).

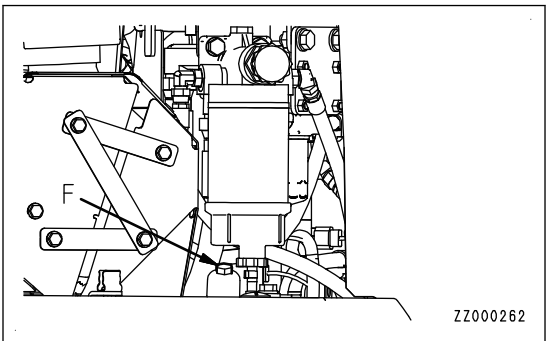



## METHOD FOR REPLACING FUEL MAIN FILTER CARTRIDGE

### WARNING

- Immediately after the engine is stopped, all parts are still very hot, so do not replace the filter immediately. Wait until all of parts cool down before starting the work.
- High pressure is generated inside the engine fuel piping system when the engine is running. When replacing the filter, wait for at least 30 seconds after stopping the engine to let the internal pressure go down before replacing the filter.
- Do not bring any open flame close.

### NOTICE

- Komatsu genuine fuel filter cartridges use a special filter that has highly efficient filtering ability. When replacing parts, Komatsu recommends using Komatsu genuine parts.
- The common rail fuel injection system used on this machine consists of more precise parts than those in the conventional injection pump and nozzles. If any cartridge other than a Komatsu genuine filter cartridge is used, dust or dirt may get in and cause problems with the injection system. Never use a substitute.
- When performing inspection and maintenance of the fuel system, be careful not to let any dirt or dust get in, more than ever before. If dust sticks to the fuel system, wash it off thoroughly with fuel.

Items to be prepared

- Container to catch fuel
- Filter wrench

1. Open inspection cover (1).

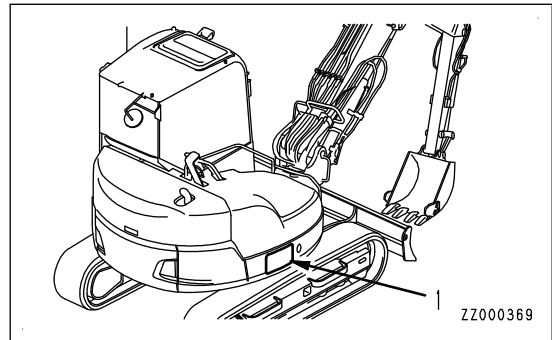

2. Turn valve (2) to CLOSE position (S).

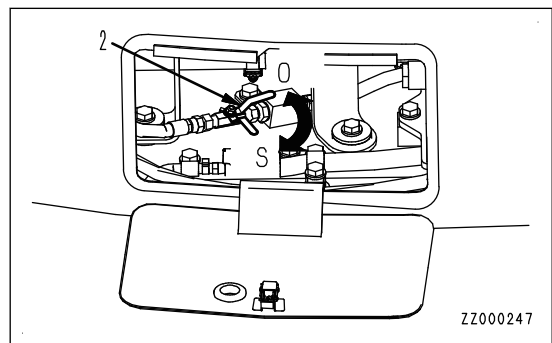

3. Open engine hood (3).
4. Securely lock the hood with hood support lever (4).

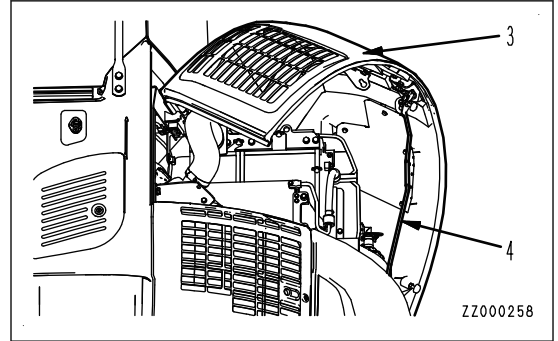

5. Place a container under filter cartridge (5) to receive the fuel.
6. Turn filter cartridge (5) counterclockwise by using the filter wrench, and remove it.
7. Clean the filter head.

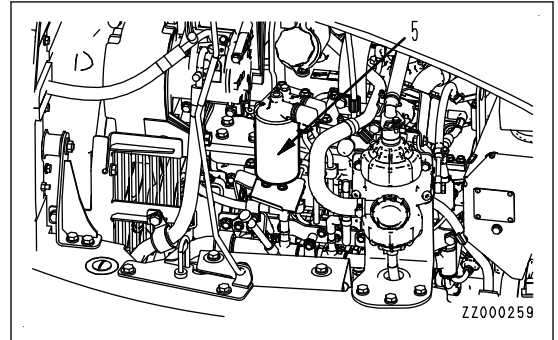

8. Thinly apply oil to the packing surface of the new filter cartridge, then install the filter cartridge to the filter head.

**NOTICE**

- Do not fill the new filter cartridge with fuel.
- Remove cap (B) at center and install the filter cartridge.

When installing the cartridge, tighten it until the packing surface contacts the seal surface of the filter holder, then tighten it one or more turns.

If the filter cartridge is tightened too far, the packing will be damaged and this will lead to leakage of fuel. If the filter cartridge is tightened too loose, fuel will also leak from the packing, so always tighten to the specified angle.

When tightening with a filter wrench, be extremely careful not to dent or damage the filter.

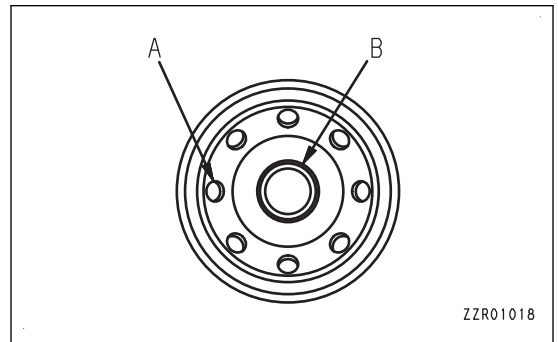

9. Turn valve (2) to OPEN position (O).
10. After completing the replacement of filter cartridge (5), bleed air according to the following procedure.
  - 1) Fill up the fuel tank with fuel (to the level where the float is at the highest position).
  - 2) Loosen the knob of feed pump (6), pull it out, then pump it in and out until the movement becomes heavy.

**REMARK**

- It is not necessary to remove the plugs at the fuel pre-filter head and at the fuel main filter head.
- When the engine runs out of fuel, use the same procedure to operate feed pump (6) and bleed the air.

11. After bleeding air, push in the knob of feed pump (6) and tighten it.
12. After replacing filter cartridge (5), start and run the engine at low idle for 10 minutes.
13. Check for leakage of oil from the filter seal surface and transparent cup mounting face.

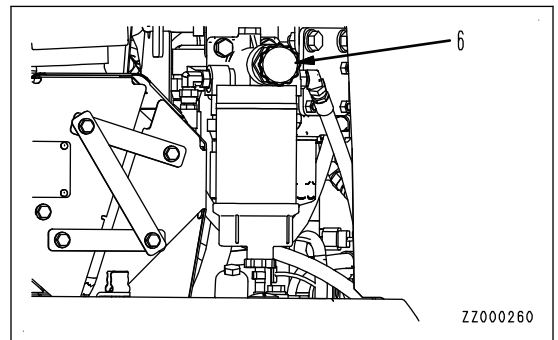

If the leakage is noticed, check the filter cartridge for its tightening condition.

If there is still fuel leakage, repeat steps 2 to 6 to remove the filter cartridge, and if any damage or pinched foreign material on the packing surface is found, replace it with a new cartridge and repeat steps 7 to 12 to install it.

### **METHOD FOR CHECKING ALL TIGHTENING POINTS OF ENGINE INTAKE PIPE CLAMPS**

Ask your Komatsu distributor for checking the tightening of the clamps between the air cleaner - turbocharger - aftercooler - engine.

### **METHOD FOR CHECKING FAN BELT TENSION AND REPLACING FAN BELT**

Special tools are required for the inspection and replacement.

Ask your Komatsu distributor to perform this work.

### **REMARK**

As the automatic fan belt tensioner is installed to this machine, no belt tension adjustment is required.

## EVERY 2000 HOURS MAINTENANCE

Maintenance for every 100, 250, 500 and 1000 hours service should be performed at the same time.

### METHOD FOR CHECKING AND RELEASING NITROGEN GAS CHARGE PRESSURE IN ACCUMULATOR (FOR CONTROL CIRCUIT)

#### **⚠ WARNING**

The accumulator is charged with high-pressure nitrogen gas, so mistaken operation may cause an explosion, which will lead to serious personal injury or death or damage. For handling, always observe the following.

- The pressure in the hydraulic circuit cannot be completely removed. When removing the hydraulic equipment, do not stand in the direction that the oil spurts out when performing the operation. In addition, loosen the bolts slowly when performing the operation.
- Do not disassemble it.
- Do not bring it near open flame or dispose of it in fire.
- Do not perform drilling, welding or flame-cutting.
- Do not hit or roll it, or subject it to any impact.
- When disposing of it, the gas must be released. Ask your Komatsu distributor to have this work performed.

#### NOTICE

If the nitrogen gas charge pressure in the accumulator is low and operations are continued, it becomes impossible to release the remaining pressure inside the hydraulic circuit if a failure occurs on the machine.

#### Function of accumulator

The accumulator has function of storing the pressure of the control circuit in it. Even after the engine is stopped, the control circuit can be operated, so the following actions are possible.

- If the control lever is operated in the direction to lower the work equipment, it is possible for the work equipment to go down under its own weight.
- The pressure in the hydraulic circuit can be released.

The accumulator is installed to the position shown in the figure.

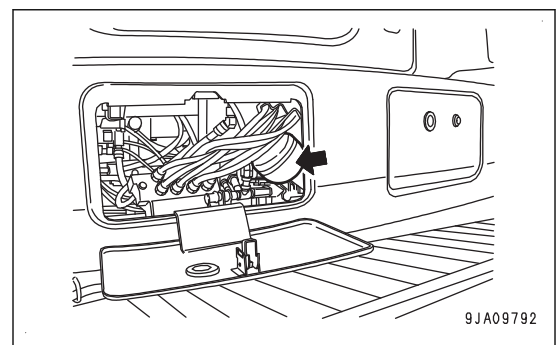

#### Method for checking function of accumulator

#### **⚠ CAUTION**

When performing the inspection, check first that there is no person or obstacle in the surrounding area.

Replace the accumulator every 2 years or every 4000 hours, whichever comes sooner.

Check the nitrogen gas charge pressure as follows.

1. Place the machine on a firm, level ground.

2. Hold the work equipment in the maximum reach posture (arm fully out, bucket fully dumped) at height 1.5 m (4 ft 11 in) from the ground.
3. Perform the following procedure within 15 seconds.

**REMARK**

After the engine stops, the accumulator pressure decreases gradually. You can check only just after the engine stops.

- 1) Keep the work equipment at the maximum reach, turn the starting switch to OFF position (A), and stop the engine.

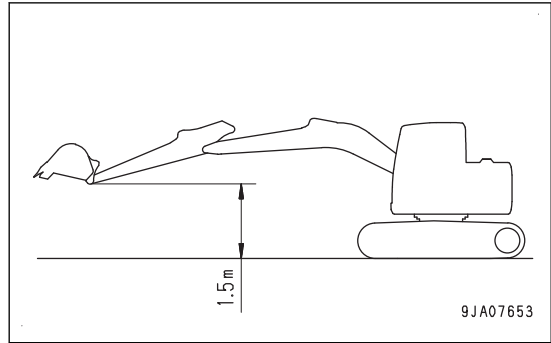

- 2) Turn the starting switch to ON position (B).

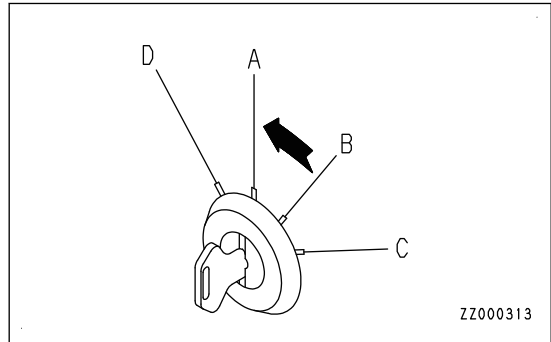

- 3) Set the lock lever to FREE position (F).
- 4) Slowly the work equipment control lever in LOWER direction and check that the work equipment touches the ground.

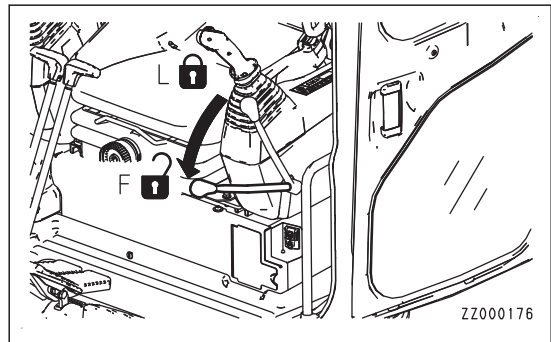
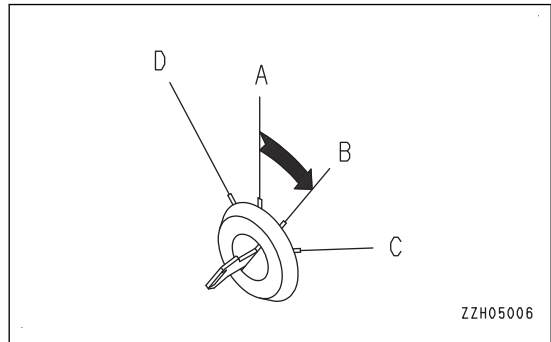

If the work equipment goes down under its weight and contacts the ground, the accumulator is normal.

If the work equipment does not go down or stops in midway, the charged pressure of the gas in the accumulator for the hydraulic circuit has probably dropped. Ask your Komatsu distributor for inspection.

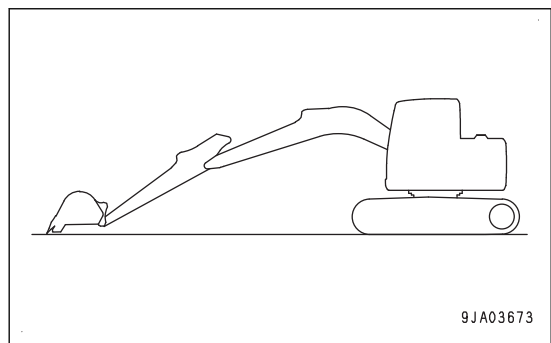

This completes the inspection. After completion of the inspection, set the lock lever to LOCK position and turn the starting switch to OFF position.

### Method for releasing pressure in hydraulic circuit

1. Lower the work equipment to the ground.

**REMARK**

Close the crusher attachment jaws, etc.

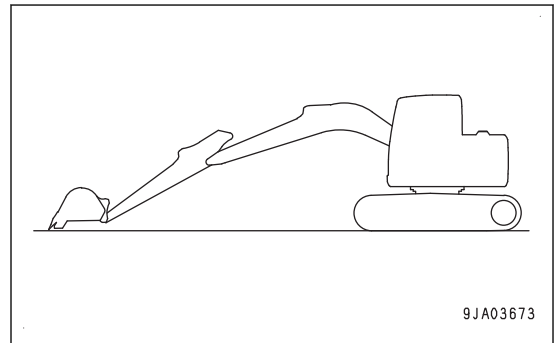

2. Set the lock lever to LOCK position (L).
3. Perform the following procedure within 15 seconds.

**REMARK**

After the engine stops, the accumulator pressure decreases gradually. You can release the pressure only just after the engine stops.

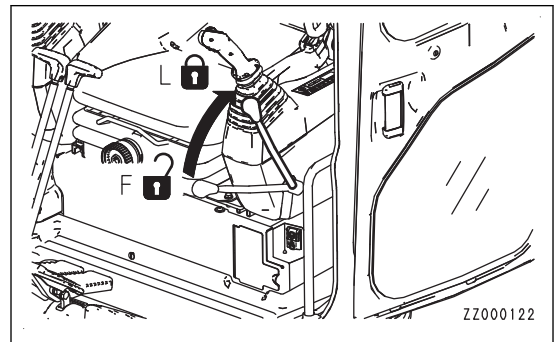

- 1) Turn the starting switch to OFF position (A), and then stop the engine.

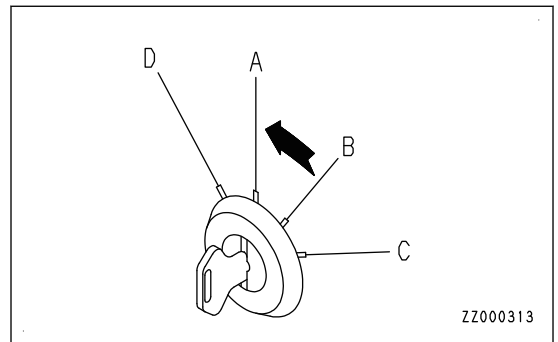

- 2) Turn the starting switch to ON position (B).

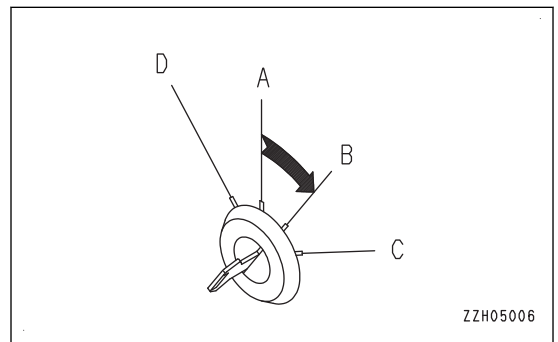

- 3) Set lock lever to FREE position (F), then operate the work equipment control levers and the attachment control switch fully to the front, rear, left, and right to release the pressure in the control circuit.

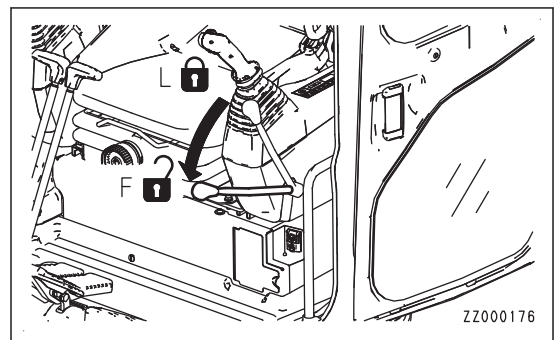

4. Set lock lever to LOCK position to lock the work equipment control levers and the attachment control pedal switch.

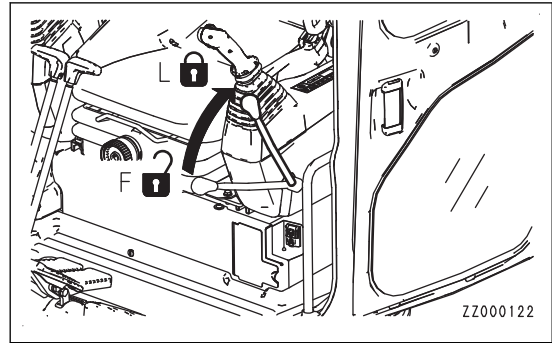

5. Turn the starting switch to OFF position (A).

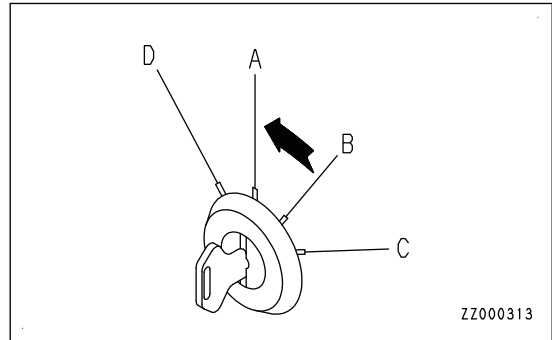

**METHOD FOR CHECKING ALTERNATOR AND STARTING MOTOR**

The brushes may be worn or the bearing may have run out of grease, contact your Komatsu distributor for inspection and repairs.

If the engine is started frequently, have this inspection performed every 1000 hours.

**METHOD FOR CHECKING AND ADJUSTING ENGINE VALVE CLEARANCE**

Special tools are necessary for inspection and maintenance. Ask your Komatsu distributor to perform this work.

## METHOD FOR REPLACING KCCV FILTER ELEMENT

### WARNING

After the engine has been operated, all of parts are still very hot. Do not replace the filter element immediately. Wait until all of parts cool down before starting the work.

### NOTICE

- If the engine is operated without the filter element, the turbocharger and aftercooler become dirty and their performance will lower and that can cause engine problems such as overrun caused by suction of oil. Therefore, do not start the engine without the filter element.
- The filter element cannot be cleaned. If the filter element is cleaned or refurbished, the filter performance lowers. As a result, the turbocharger and aftercooler become dirty and the crankcase pressure increases. Never reuse the filter element since it can cause an engine failure.
- After the filter element is replaced, if KCCV is not assembled correctly, oil or blowby gas may leak. Replace the filter element in the correct procedure.

Prepare a container to catch oil.

The KCCV ventilator is located in the positions shown in the figure.

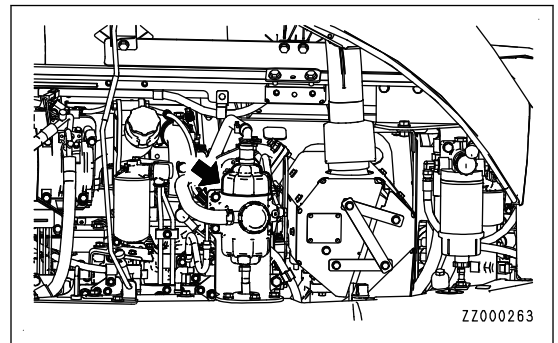



1. By using tools, loosen bolt (3) and nut (4) of elbow (2) above KCCV ventilator (1).
2. Move loosened bolt (3) and nut (4) along the groove of elbow (2) to position (A) shown in the figure.

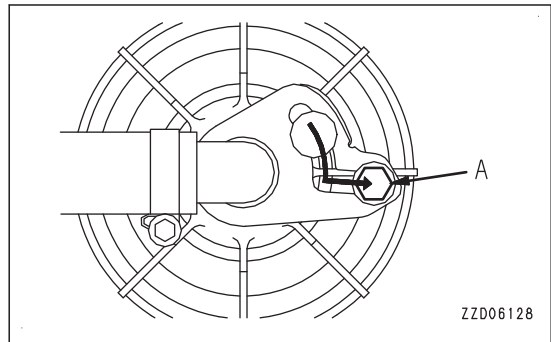
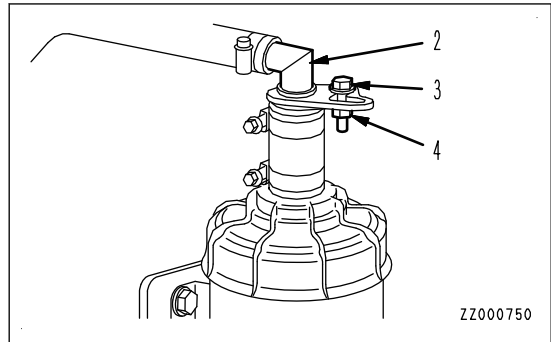
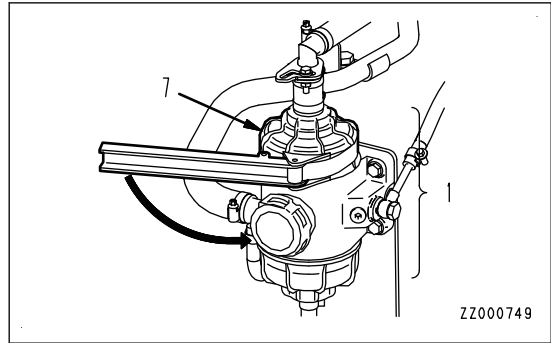

3. By using the filter wrench, loosen cover (7) of KCCV ventilator (1).  
At this time, tube (5) and hose (6) rotate together with cover (7).

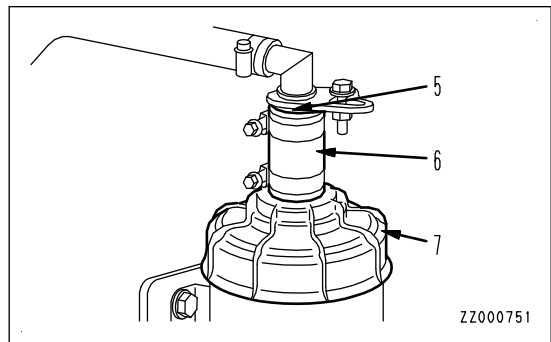
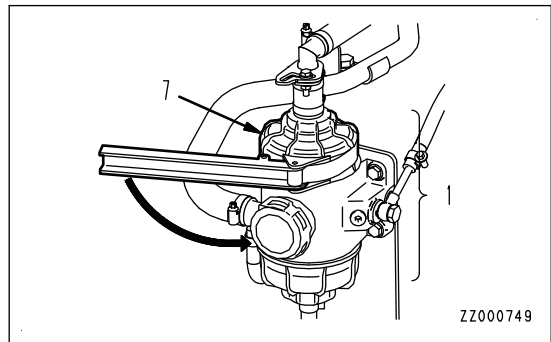

- After removing cover (7) from ventilator body (8), remove element (9).

Oil may be accumulated in or sticking to cover (7) and element (9). When replacing the element, take care that the oil will not spill out.

**REMARK**

When the ambient temperature is low, water or emulsified matter may stick to the inside of KCCV because of condensation of water vapor in the blowby gas. However, as far as the coolant level is normal, it is not a problem.

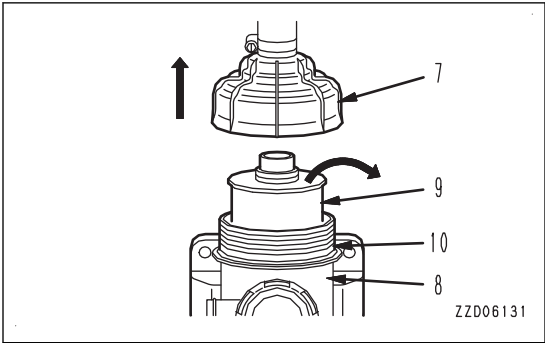

- Apply engine oil to O-rings (11) (2 pieces) fitted to the top and bottom of the new element and insert the element into the body.

**REMARK**

You can install the element with either side up.

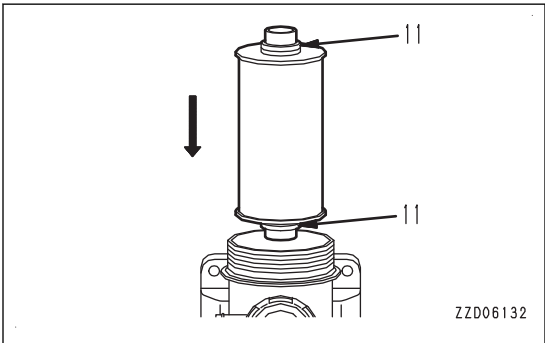

- Replace O-ring (10) of ventilator body (8) with new one and apply engine oil to it, and then install cover (7) to the body.

Tighten the cover firmly with the hand until you cannot tighten any more.

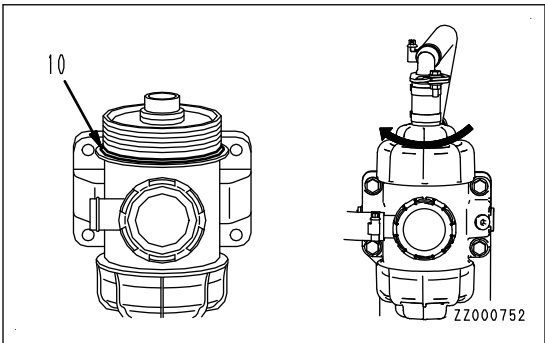

- Tighten the cover until clearance (B) between it and body is eliminated with the bare hand or by using a filter wrench. At this time, check that bolt-fixed position (C) of tube (5) is within the range of the groove of elbow (2).

**REMARK**

As a mark, notch (D) is made on the plate.

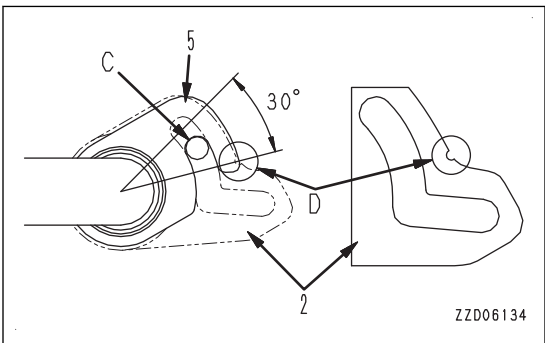
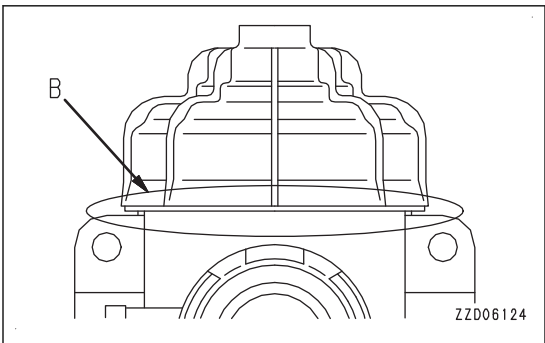

8. By using tools, tighten bolt (3) and nut (4).

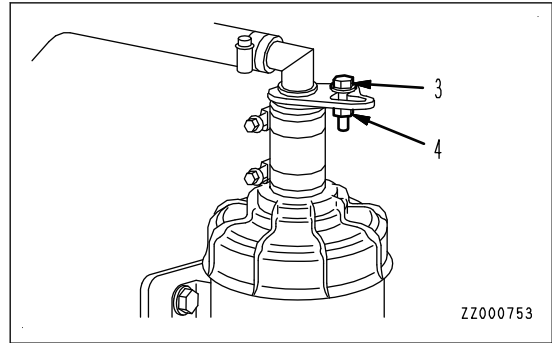

Check the KCCV hose for leakage, crack, and loose clamp, and replace it if necessary.

### EVERY 4000 HOURS MAINTENANCE

Maintenance for every 100, 250, 500, 1000 and 2000 hours service should be performed at the same time.

### REPLACE DEFINED LIFE PARTS

Material quality of these parts can change as time passes and they are likely to wear out or deteriorate.

Replace them every 2 years or every 4000 hours, whichever comes sooner.

### DEFINED LIFE PARTS LIST

No.	Parts for periodic replacement		Replacement interval
1	Fuel system	Fuel hose Spill hose	Ask your Komatsu distributor for replacement.
2	Engine lubrication system	Turbocharger lubricating oil hose Engine oil filter hose	
3	Work equipment hydraulic system	Main pump delivery hose Main pump LS hose Swing line hose	
		External work equipment hoses <ul style="list-style-type: none"> <li>• Boom foot connection hose</li> <li>• Boom cylinder hose</li> <li>• Arm connection hose</li> <li>• Arm cylinder hose</li> <li>• Bucket cylinder hose</li> <li>• Travel line hose</li> <li>• Attachment additional line hose</li> <li>• Blade cylinder hose</li> <li>• Boom swing cylinder hose</li> </ul>	
4	Others	PPC ACCUMULATOR Accumulator for additional attachment	

**METHOD FOR CHECKING WATER PUMP**

Check for play of the pulley, oil leakage, water leakage, and clogging of weep hole (drain hole). If anything abnormal is found, ask your Komatsu distributor for disassembly and repair or replacement.

**METHOD FOR REPLACING ACCUMULATOR (FOR CONTROL CIRCUIT)**

**! WARNING**

The accumulator is charged with high-pressure nitrogen gas, so mistaken operation may cause an explosion, which will lead to serious injury or death or damage. For handling, always observe the following.

- The pressure in the hydraulic circuit cannot be completely removed. When removing the hydraulic equipment, do not stand in the direction that the oil spurts out when performing the operation. In addition, loosen the bolts slowly when performing the operation.
- Do not disassemble it.
- Do not bring it near open flame or dispose of it in fire.
- Do not perform drilling, welding or flame-cutting.
- Do not hit or roll it, or subject it to any impact.
- When disposing of it, the gas must be released. Ask your Komatsu distributor to have this work performed.

**NOTICE**

If the nitrogen gas charge pressure in the accumulator is low and operations are continued, it becomes impossible to release the remaining pressure inside the hydraulic circuit if a failure occurs on the machine.

Replace the accumulator every 2 years or every 4000 hours, whichever comes sooner.

Ask your Komatsu distributor for replacement.

The accumulator is installed to the position shown in the figure.

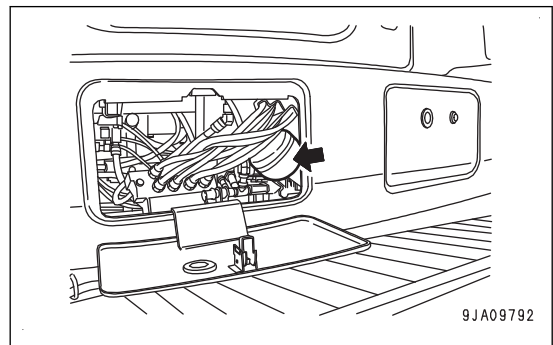

**METHOD FOR CHECKING FOR LOOSENESS OF ENGINE HIGH-PRESSURE PIPING CLAMP, HARDENING OF RUBBER**

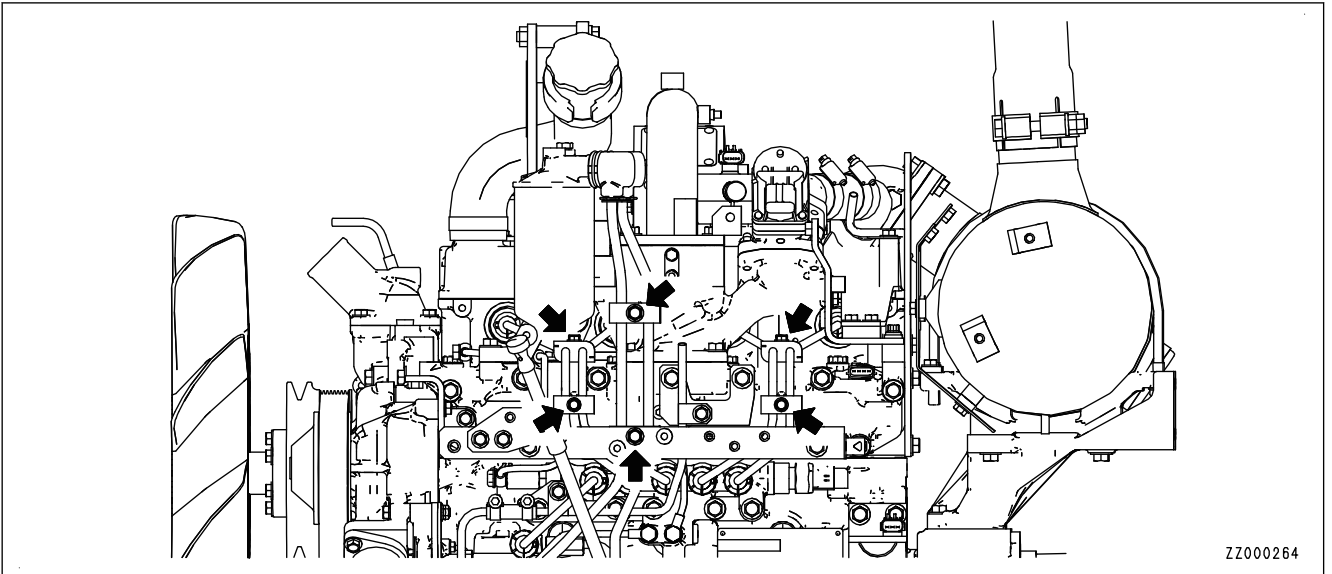

ZZ000264

Check visually and touch by hand to check that there is no hardening of the rubber and no loose bolts of the mounting clamps (6 places) for the high-pressure piping between the supply pump and the common rail.

If there are any problems, the replacement must be performed. Ask your Komatsu distributor for replacement.

**METHOD FOR CHECKING FOR MISSING FUEL SPRAY PREVENTION CAP, HARDENING OF RUBBER**

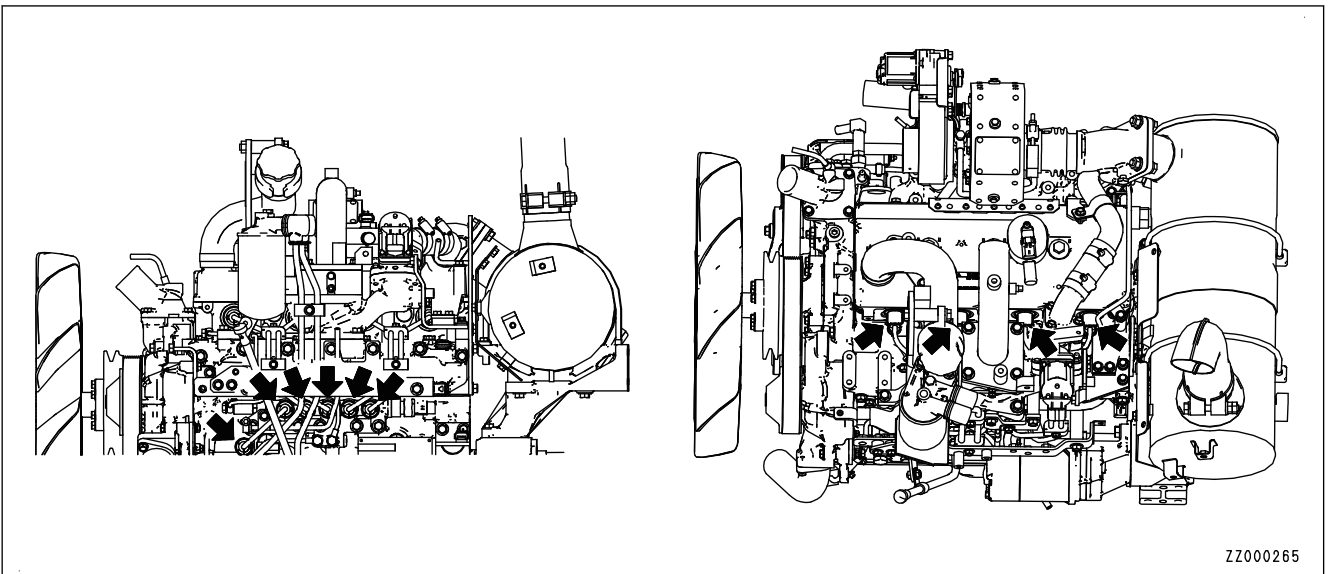

ZZ000265

The fuel spray prevention caps (10 places) on the fuel injection piping and both ends of the high-pressure piping act to prevent the fuel from coming into contact with high-temperature parts of the engine and causing a fire if the fuel should leak or spray out.

Check visually and touch by hand to check that there are no missing fuel spray prevention cap, loose bolts or hardening of the rubber.

If there is any problem, the replacement must be performed. Ask your Komatsu distributor for replacement.

## EVERY 5000 HOURS MAINTENANCE

Maintenance for every 100, 250, 500 and 1000 hours service should be performed at the same time.

### METHOD FOR CHANGING OIL IN HYDRAULIC TANK, CLEANING HYDRAULIC TANK STRAINER

#### **! WARNING**

- Immediately after the engine is stopped, its parts and oil are still very hot and may cause burn injury. Wait for the temperature to go down, and start the work.
- When removing the oil filler cap, the oil may spout out. Turn it slowly to release the internal pressure, then remove it.

#### NOTICE

If the machine is equipped with a hydraulic breaker, the hydraulic oil deteriorates faster than in the normal bucket digging operation. Accordingly, perform maintenance referring to “MAINTENANCE INTERVAL FOR HYDRAULIC BREAKER”.

Refill capacity: 56 l {14.8 U.S.Gal}

Items to be prepared

- Container to receive drained oil
  - Socket wrench handle
1. Swing the upper structure so that the drain plug at the bottom of the hydraulic tank is in the middle between the left and right tracks.
  2. Retract the arm and bucket cylinder rods, swing the boom to the center, and lower it to lower the teeth to the ground.
  3. Lower the blade.
- 
4. Set the lock lever to LOCK position (L).
  5. Stop the engine.

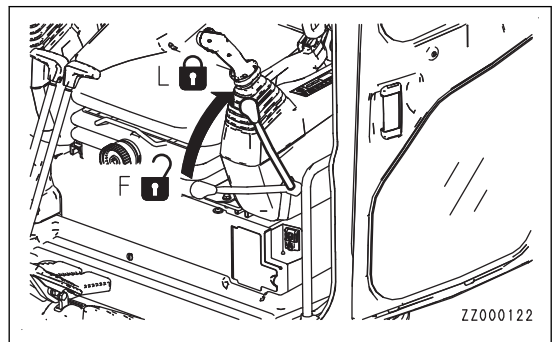
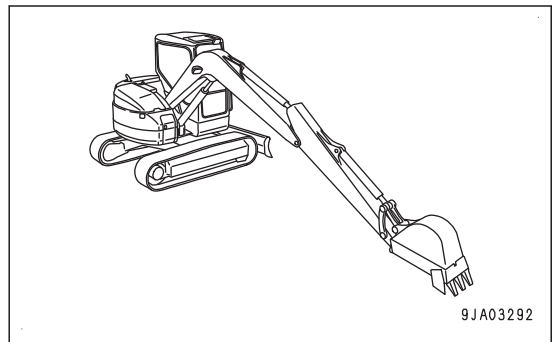

6. Open dirt cover (1).
7. Lock securely with cover support lever (2).
8. Loosen bolt (3) and remove plate (4) on the top of oil filler port (F).
9. Remove the cap of oil filler port (F) gradually to release the internal pressure.
10. Remove the cap of oil filler port (F).

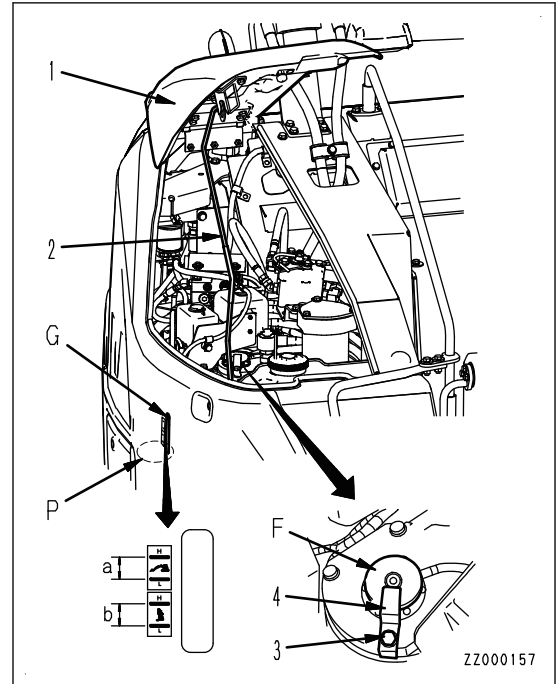

11. Loosen bolt (5) and move cover (6) at the bottom of the machine.

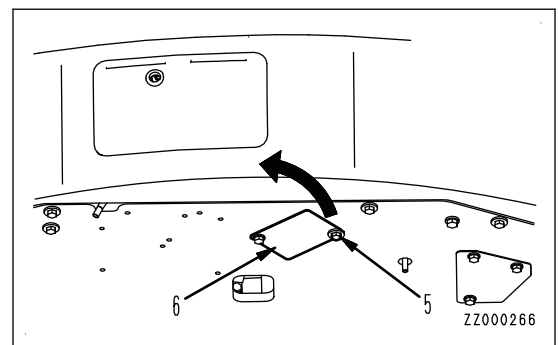

12. Place the oil container under drain plug (P) at the bottom of the machine.
13. Remove drain plug (P) to drain the oil by using the socket wrench handle.
  - When removing drain plug (P), be careful not to get oil on yourself.  
Check the installed O-ring for damage. If it is damaged, replace it.

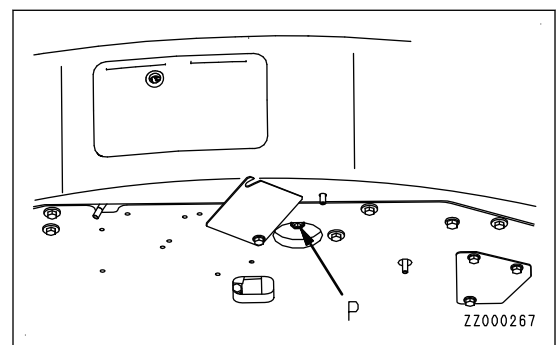

14. After draining the oil, tighten drain plug (P).  
Tightening torque : 58.8 to 78.4 Nm {6 to 8 kgm, 43.4 to 57.9 lbf}
15. Return cover (6) to its original position and fix it with bolt (5).



- 16. Loosen the bolts (4 pieces) and remove cover (7).  
At this time, cover (7) may jump out under the force of spring (8). Remove the bolts while pressing the cover (7) down a.
- 17. Hold the top of rod (9), pull it up, and remove spring (8) and strainer (10).
- 18. Remove all dirt from strainer (10), then wash it in clean diesel fuel or flushing oil.  
If strainer (10) is damaged, replace it with a new one.
- 19. Insert strainer (10) and set it in protruding part (11) of the tank.
- 20. Install cover (7) with the bolts while pressing it with the hand.  
Check O-ring fitted to cover (7). If it is damaged, replace it with a new one.
- 21. Add the refill capacity of oil through oil filler port (F).
- 22. Check that the oil level is between H and L lines on sight gauge (G).

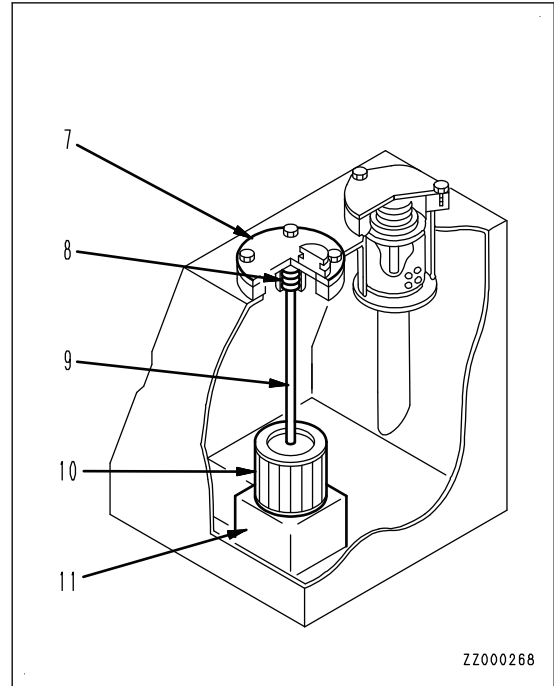

ZZ000268

For applicable oils, see "METHOD FOR USING FUEL, COOLANT AND LUBRICANTS ACCORDING TO AMBIENT TEMPERATURE".

For the method of checking the oil level, see "METHOD FOR CHECKING OIL LEVEL IN HYDRAULIC TANK, ADDING OIL".

- 23. Install the cap of oil filler port (F).
- 24. Start the engine.
- 25. Swing the boom to the center and fully extend the boom, arm, and bucket cylinders as shown in the figure.
- 26. After removing the oil filler cap, install it to pressurize the tank.

**NOTICE**

**If the hydraulic tank is not pressurized, air is sucked in the pump and it affects the components badly.**

- 27. Move plate (4) to the center of the cap and fix it with bolt (3).
- 28. Remove cover support lever (2) and fix it to the lever lock securely.
- 29. Close dirt cover (1).
- 30. Bleed air from the hydraulic circuit.

For the air bleeding procedure of hydraulic circuit, see "METHOD FOR BLEEDING AIR FROM HYDRAULIC CIRCUIT".

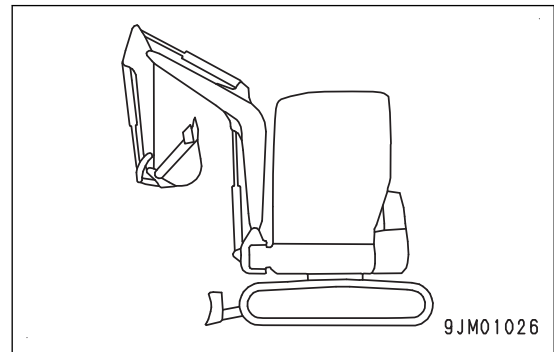

9JM01026

# **SPECIFICATIONS**

# SPECIFICATIONS

Item		Unit	Road liner specification
Machine weight (including blade)		kg (lb)	8640 (19050)
Bucket capacity		m <sup>3</sup> (cu/yd)	0.20 (0.26)
Engine model		-	Komatsu SAA4D95LE-6 diesel engine
Rated horsepower	SAE J1995 (Gross)	kW {HP} / min <sup>-1</sup> {rpm}	50.7 {68.0} / 1950 {1950}
	ISO 9249/ SAE J1349 (Net)		48.8 {65.5} / 1950 {1950}
A	Overall length	mm (ft in)	6430 (21' 1")
B	Overall height	mm (ft in)	2760 (9' 1")
			2730 (8' 11") (*1)
C	Overall width	mm (ft in)	2330 (7' 8")
D	Shoe width	mm (ft in)	450 (1' 6")
E	Tail swing radius	mm (ft in)	1485 (4' 10")
F	Overall length of track	mm (ft in)	2890 (9' 6")
			2840 (9' 4") (*1)
G	Distance between tumbler centers	mm (ft in)	2235 (7' 4")
Min. ground clearance		mm (ft in)	410 (1' 4")
Travel speed (Lo/Hi)		km/h (MPH)	2.8 / 5.0 (1.7 / 3.1)
Continuous swing speed		rpm	10.0

(\*1): Steel shoe specification

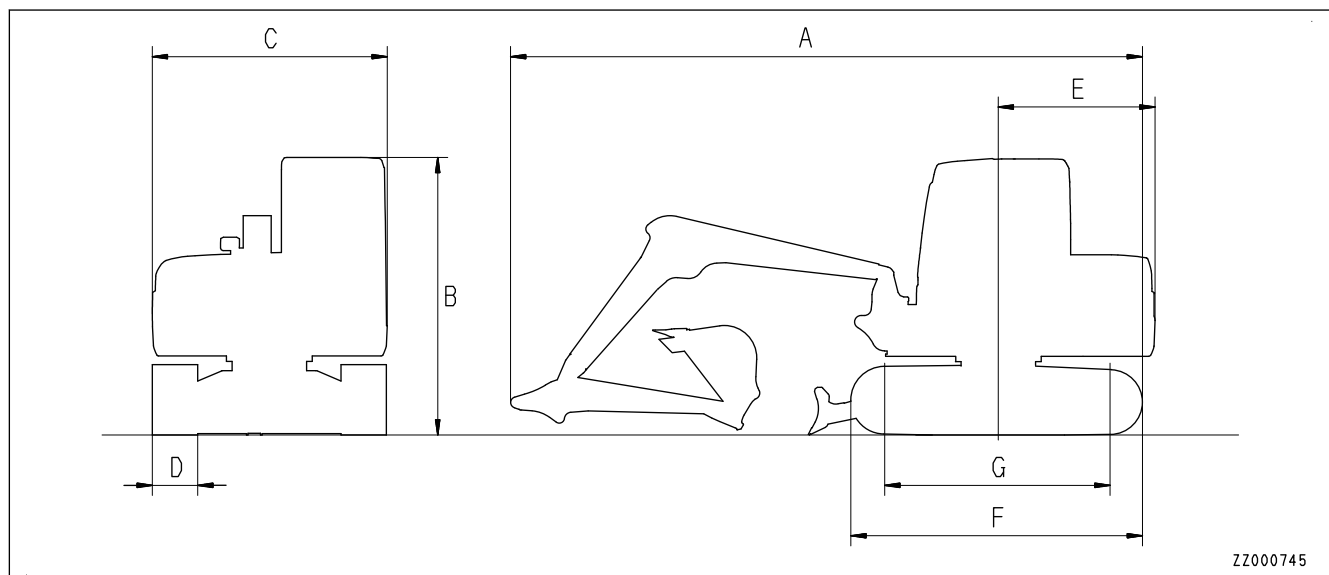

ZZ000745

**Road liner specification**

	Working ranges (mm)	Unit	2100 mm arm specification
A	Max. digging reach	mm (ft in)	7345 (24' 1")
B	Max. digging depth	mm (ft in)	4565 (15' 0")
C	Max. digging height	mm (ft in)	6800 (22' 4")
D	Max. vertical wall digging depth	mm (ft in)	3115 (10' 3")
E	Max. dumping height	mm (ft in)	4770 (15' 8")
F	Min. swing radius of work equipment	mm (ft in)	2900 (9' 6")
	Min. swing radius of boom		2545 (8' 4")
G	Max. reach at ground level	mm (ft in)	7135 (23' 5")
H	Max. blade lift above ground	mm (ft in)	550 (1' 10")
I	Max. blade drop below ground	mm (ft in)	390 (1' 3")

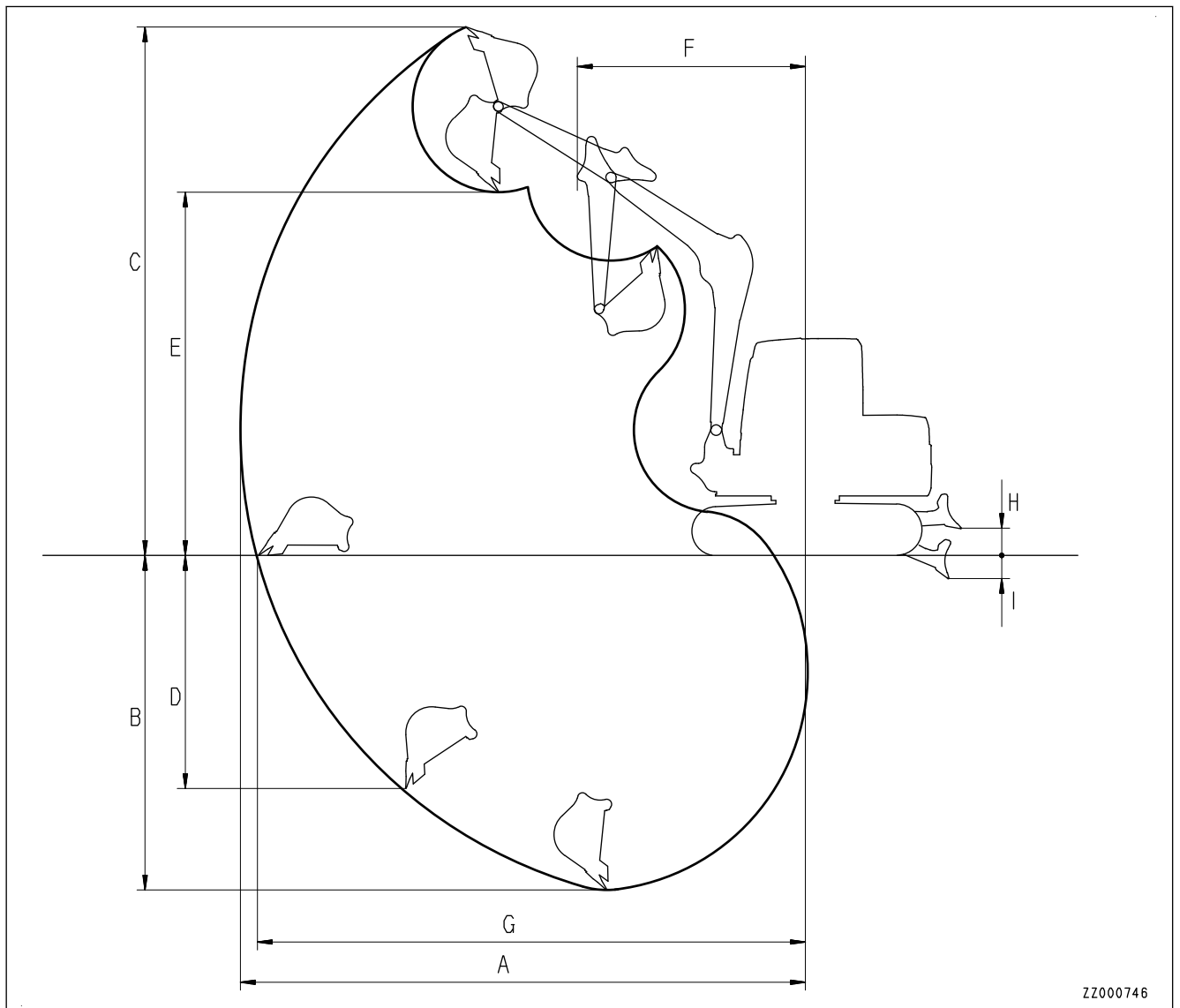

ZZ000746



# ATTACHMENTS AND OP- TIONS

## **WARNING**

Please read and make sure that you understand the SAFETY section before reading this section.

---

# GENERAL PRECAUTIONS

## Precautions for safety

If attachments or options other than those authorized by Komatsu are installed, this will not only affect the life of the machine, but will also cause problems with safety.

When installing attachments not listed in this Operation and Maintenance Manual, contact your Komatsu distributor first. If you do not contact Komatsu, we cannot accept any responsibility for any accidents or failures.

### **WARNING**

#### General precautions

- Read the instruction manual for the attachment carefully, and you must understand the operation method completely before using the machine.  
If you lose the instruction manual, be sure to order another copy from the manufacturer or your Komatsu distributor.
- Install a front guard, etc. necessary to the machine, depending on attachments.
- For the attachment generating hitting sound, it may be difficult to communicate work instructions between coworkers. Appoint a signalman and decide signals in advance.
- Never swing the work equipment sideways with a heavy load on it. Swinging on a slope is more dangerous.
- If the machine is equipped with the breaker, it is unstable since a load larger than the bucket is applied to the front of the work equipment. Never work with the work equipment on the right or left side of the machine to avoid risk of tipping over.
- If an attachment is installed, the swing range and the center of gravity of the machine change, and consequently the machine moves unexpectedly. Grasp the condition of the machine.
- Before starting the work, make fences around the machine so that no person enters the work area. Never move the machine while someone is near it.
- To prevent serious personal injury or death caused by misoperation, you must not place your foot on the pedal except when operating the pedal.

#### Precautions for removal and installation

When removing or installing an attachment, observe the following items and work safely.

- Select a firm, level surface when installing or removing an attachment.
- When working in cooperation with one or more other workers, decide signs and observe them when performing the operation.
- When carrying a heavy part (25 kg (55 lb) or more), use a crane.
- When removing a heavy part, always place a support in position before removing it.
- When lifting a load with a crane, be particularly careful of the center of gravity.
- It is dangerous to perform works when the load has been raised by a crane. Always lower the load onto a stand and check that it is safe.
- When leaving an attachment removed or installing it, place it in a stable position to prevent it from falling over.
- Never go under a load raised by a crane.  
Always stand in a place which is safe even if the load should fall.

---

#### NOTICE

Qualifications are required to operate a crane. Never allow the crane to be operated by an unqualified person.

For details of removal and installation operations, contact your Komatsu distributor.

## Installing attachments

### WARNING

If a long or heavy work equipment is installed, the machine stability is reduced and the machine may be unbalanced and may tip over when it travels down a steep slope or swings on a slope.

Do not perform the following works since they are very dangerous.

- Traveling down with work equipment raised
- Sideways travel on slope
- Swinging on slope
- If a heavy work equipment is installed, the swing over-run (the distance the work equipment moves before completely stopping after the swing brake is applied) increases, thus you may hit it by judging distance wrongly.

Always maintain a safe distance to a stop position when operating. In addition, the hydraulic drift (the phenomenon that the work equipment lowers gradually by its own weight when it held in air) increases, as well.

- The boom and arm can cause serious loss unless they are installed according to a correct procedure. In such cases, consult your Komatsu distributor.
- If a long work equipment is installed, you may hit it by judging distance wrongly since the working range increases remarkably.  
Always maintain a safe distance from obstacles in the surrounding area when operating.

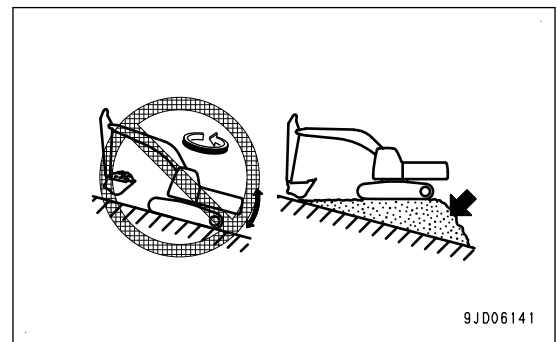
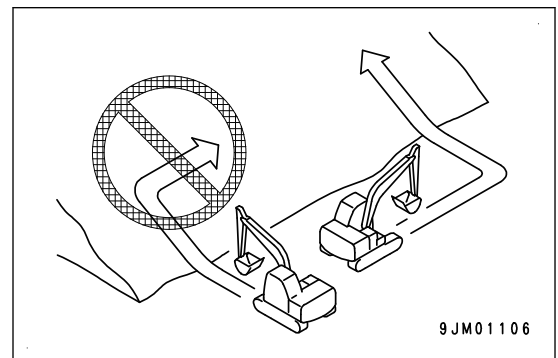
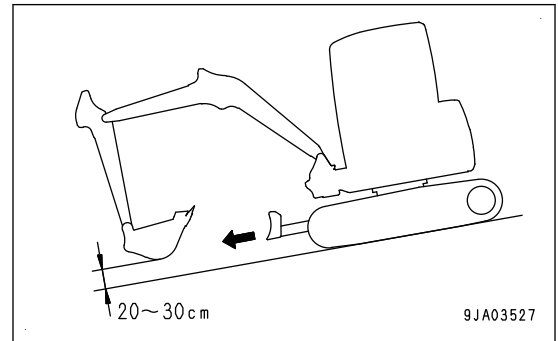



## HANDLE BUCKET WITH HOOK

When using the bucket with hook, check that there is no damage to the hook, stopper, or hook mount. If there is any problem, ask your Komatsu distributor.

### PRECAUTIONS FOR OPERATION

#### PRECAUTIONS FOR LIFTING OPERATIONS

- During lifting operations, reduce the engine speed and perform the operation in L mode.
- Depending on the posture of the work equipment, there is a danger that the wire or load may slip off the hook. Always be careful to maintain the correct hook angle to prevent the slipping-off.
- Never drive the machine while lifting a load.
- If the bucket with hook is turned 180 deg. and used for operations, it will hit the arm during the bucket DUMP operation. Be careful when using it.
- If you are planning to newly install a hook, ask your Komatsu distributor for installation.

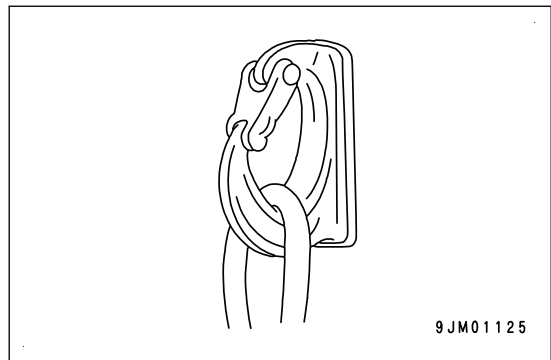
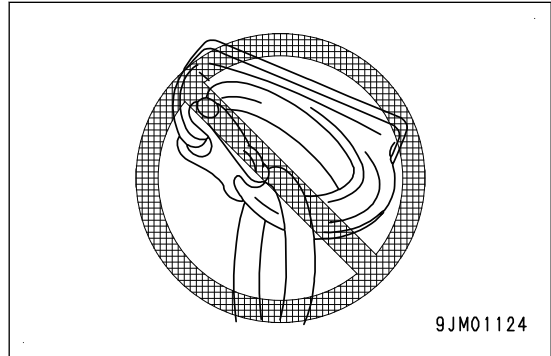

# HANDLE MACHINE READY FOR INSTALLATION OF ATTACHMENT

## EXPLANATION OF COMPONENTS

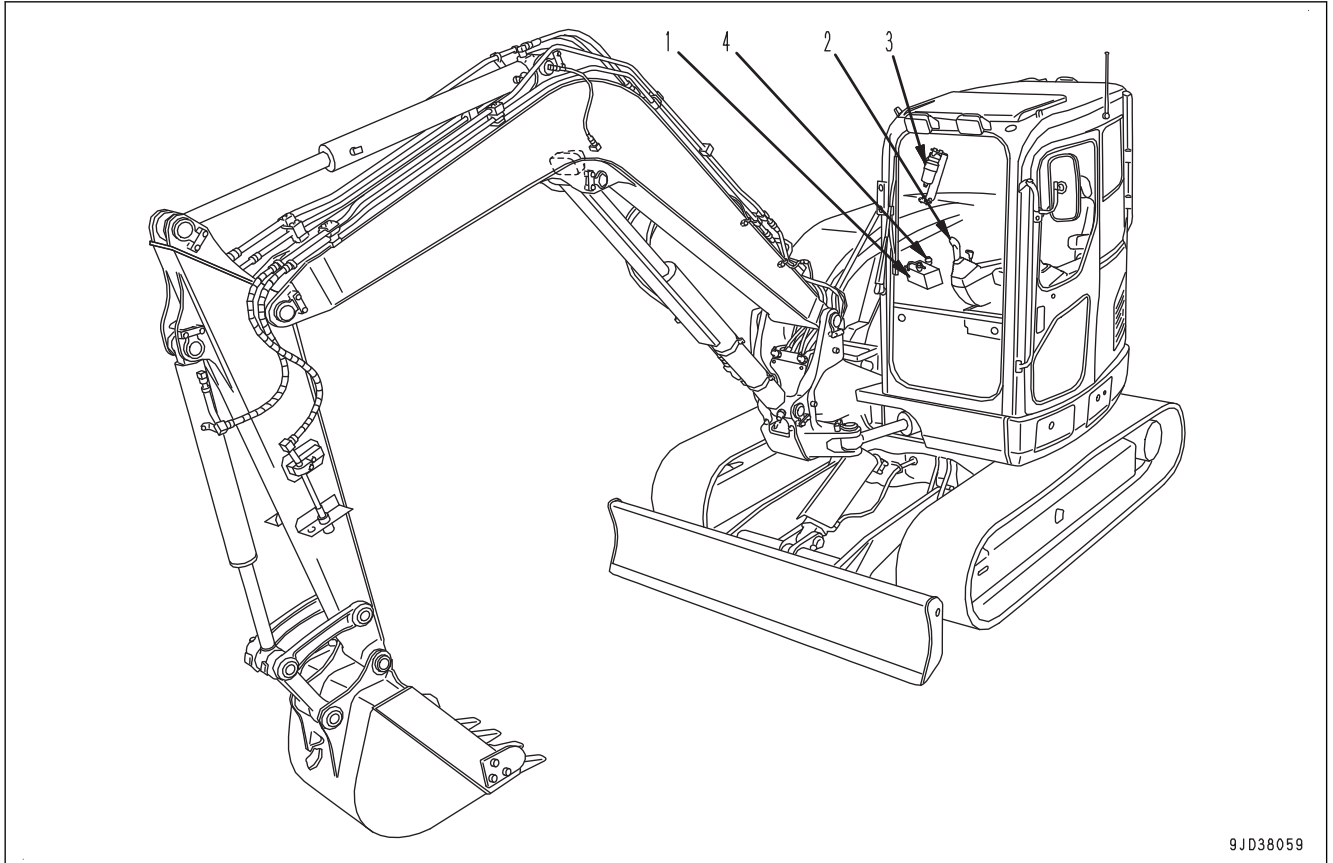

9J038059

(1) Selector valve

(2) Breaker operation switch

(3) Additional filter for breaker

(4) Accumulator (for low pressure)

### SELECTOR VALVE

The selector valve switches the flow of the hydraulic oil.

#### Position (a)

When using the breaker:

#### Position (b)

When general attachments such as crusher are used:

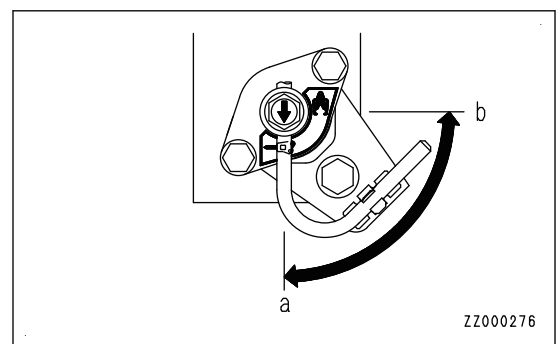

ZZ000276

## BREAKER OPERATION SWITCH

The breaker operation switch is used to operate the breaker.

If this switch is pushed, the breaker operates.

The breaker does not operate unless the breaker mode is set on the machine monitor.

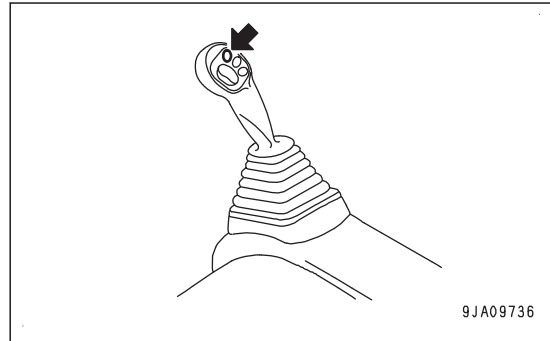

## ADDITIONAL FILTER FOR BREAKER

The additional filter for breaker prevents deterioration of the hydraulic oil when using a breaker.

The oil flows only when the selector valve is set in the breaker position.

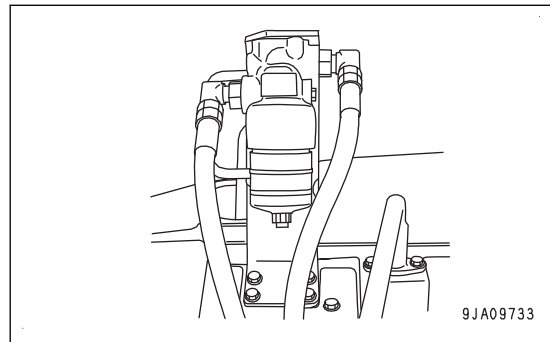

## ACCUMULATOR (FOR LOW PRESSURE)

The accumulator (for low pressure) is installed to protect the oil cooler when the breaker is used.

For necessity of this accumulator, consult the attachment manufacturer.

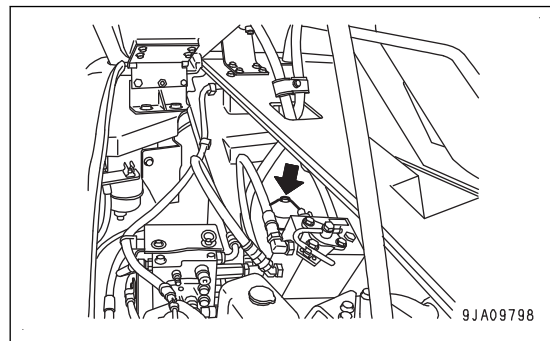

## HYDRAULIC CIRCUIT

### METHOD FOR CONNECTING HYDRAULIC CIRCUIT

When installing the attachment, connect the hydraulic circuit as follows.

1. Connect the attachment piping provided by the attachment manufacturer.  
The dimensions on the machine side are as shown in the figure.
2. After connecting the piping, bleed air from the circuit according to the following procedure.

#### NOTICE

**If the air bleeding procedure is specified on the attachment by the manufacturer, bleed the air according to that procedure.**

- 1) Start the engine.  
Run the engine at low idle for 10 minutes, and then start the following work.
- 2) To bleed all air from the attachment circuit, operate the attachment operation switch repeatedly (approximately 10 times) while running the engine at low idle.
- 3) After completing the air bleeding, stop the engine, leave the machine for 5 minutes, and then start the operation.  
The air bubbles in the oil inside the hydraulic tank are discharged.
- 4) Check that there is no leakage of oil and wipe off any oil that is spilled.

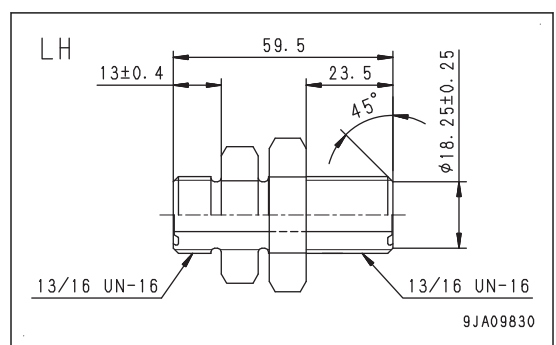
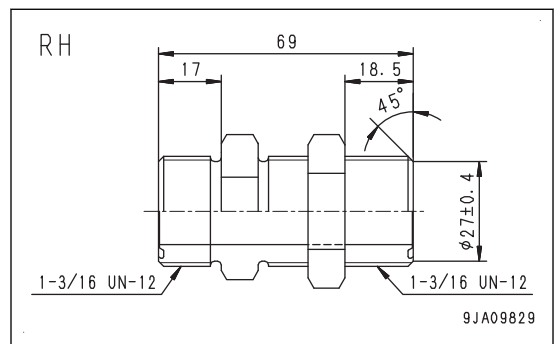
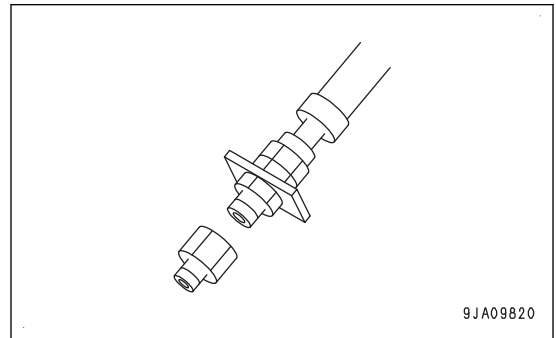

## METHOD FOR REMOVING AND INSTALLING ATTACHMENT

### WARNING

Lower the attachment to the ground and stop the engine.

### METHOD FOR REMOVING ATTACHMENT

1. Lower the attachment to the ground and stop the engine.
2. Turn the starting switch to ON position (B).

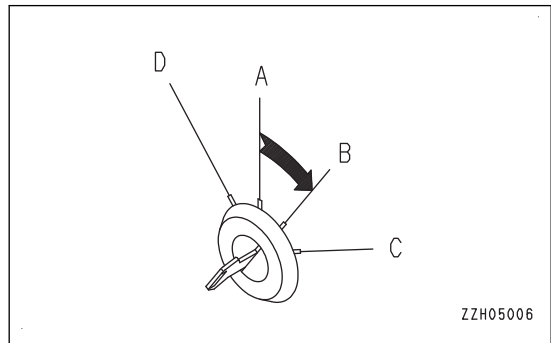

3. Set the lock lever to FREE position (F).

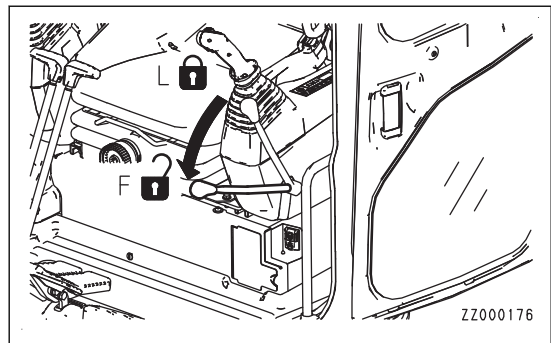

4. Operate each control lever (work equipment, travel) and attachment control switch fully in each direction within 15 seconds after the engine is stopped to release the internal pressure in the hydraulic circuit.

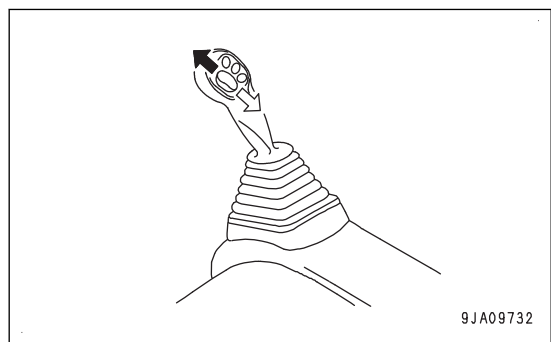
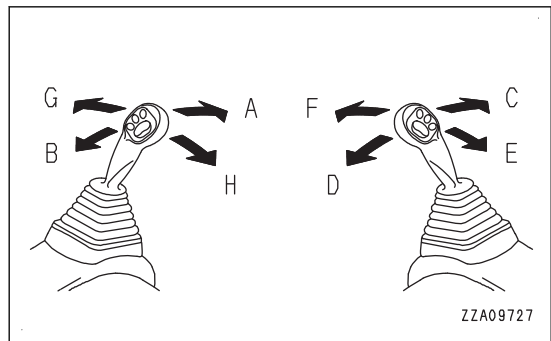

5. Set the lock lever to LOCK position (L).

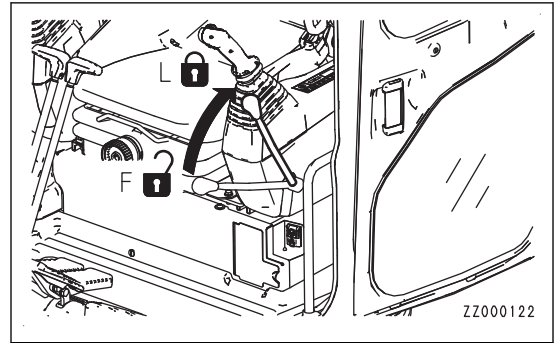

6. Turn the starting switch to OFF position (A).

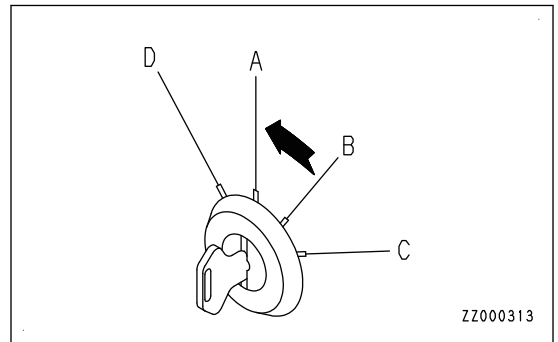

7. Open dirt cover (1).  
 8. Lock securely with cover support lever (2).  
 9. Loosen bolt (3) and remove plate (4) on the top of oil filler port (F).  
 10. Remove the cap of oil filler port (F) gradually to release the internal pressure.  
 11. Remove the cap of oil filler port (F).

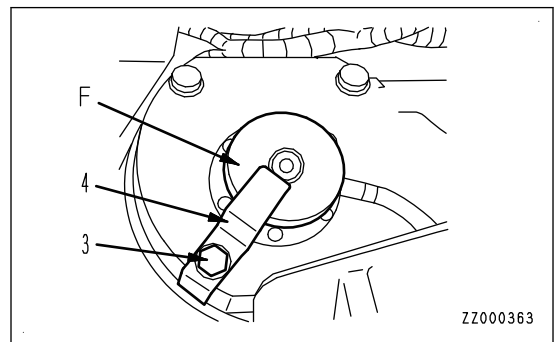
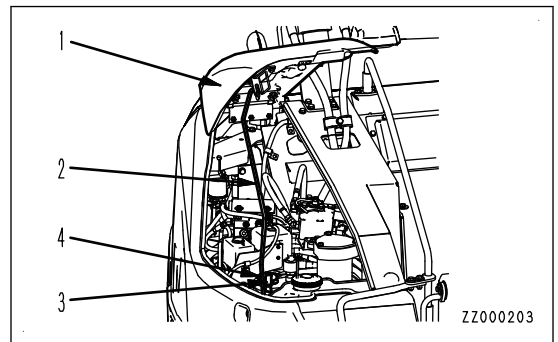

12. Remove the hoses on the attachment side. Install the plugs to outlets (2 places).

The plugs are used to prevent the attachment from making incorrect operation caused by mixing in of foreign matter. After the plugs are correctly installed, store the attachment.

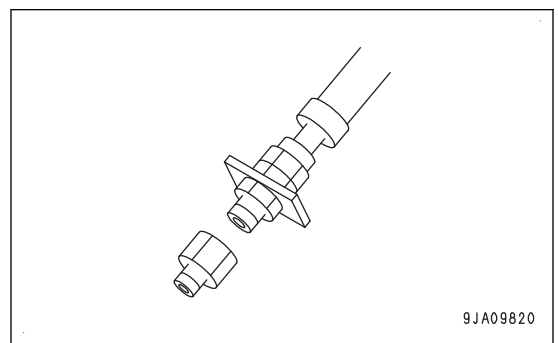

13. Pull out the mounting pins (2 places), remove the attachment, then install the bucket.

For the installation procedure of the bucket, see "METHOD FOR REPLACING AND INVERTING BUCKET".

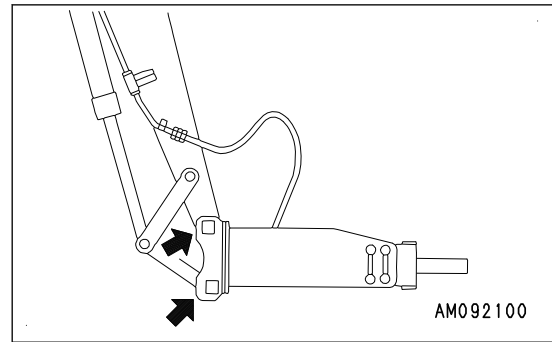

After installing the bucket, check the oil level in the hydraulic tank.

## METHOD FOR INSTALLING ATTACHMENT

1. Remove the bucket.

For the removal procedure of the bucket, see "METHOD FOR REPLACING AND INVERTING BUCKET".

2. Place the attachment on a horizontal place, install pin (A) and then pin (B) in this order to the arm.
3. Lower the attachment to the ground and stop the engine.

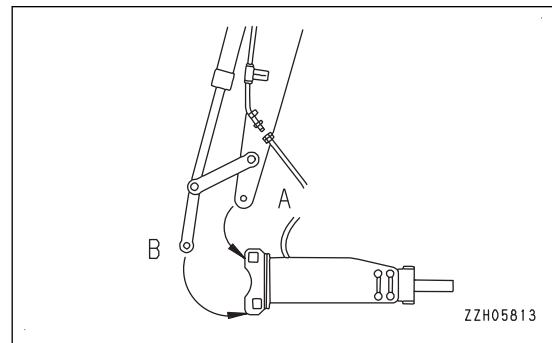

4. Turn the starting switch to ON position (B).

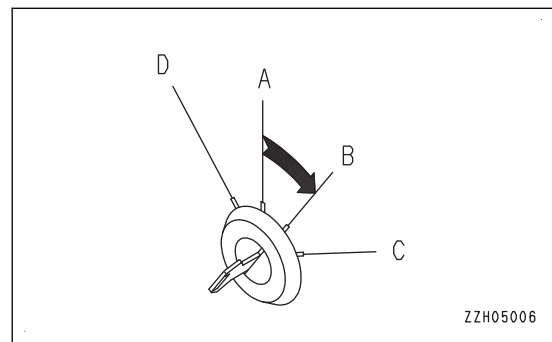

5. Set the lock lever to FREE position (F).

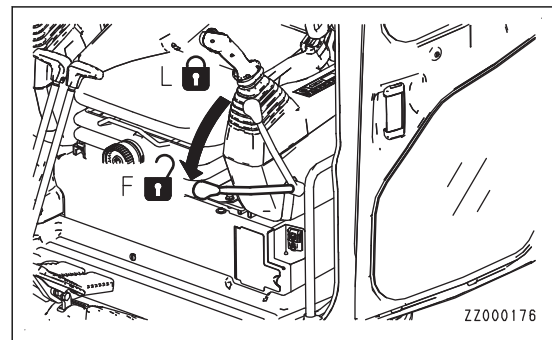

- Operate each control lever (work equipment, travel) and attachment control switch fully in each direction within 15 seconds after the engine is stopped to release the internal pressure in the hydraulic circuit.

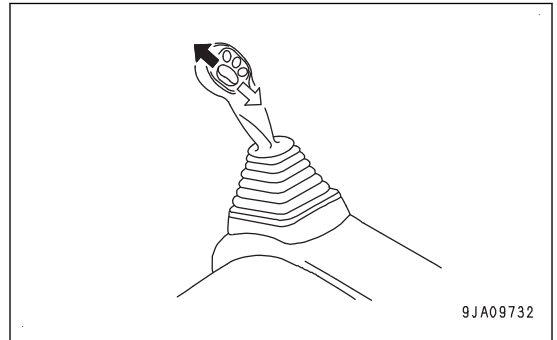
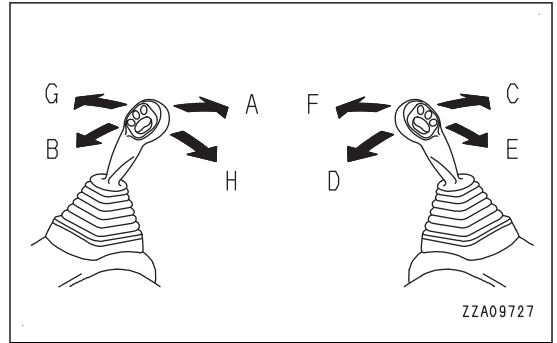

- Set the lock lever to LOCK position (L).

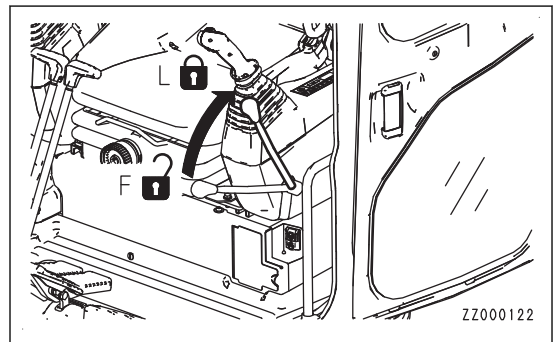

- Turn the starting switch to OFF position (A).

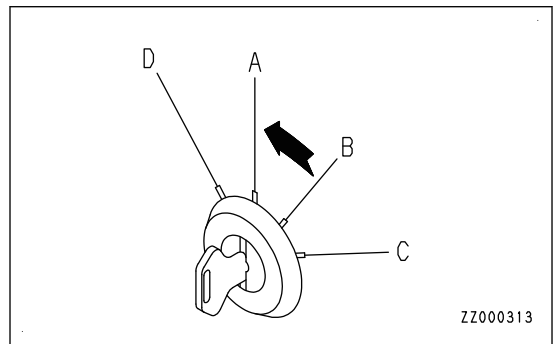



9. Open dirt cover (1).
10. Lock securely with cover support lever (2).
11. Loosen bolt (3) and remove plate (4) on the top of oil filler port (F).
12. Remove the cap of oil filler port (F) gradually to release the internal pressure.
13. Remove the cap of oil filler port (F).
14. Check that the hydraulic oil temperature is low.

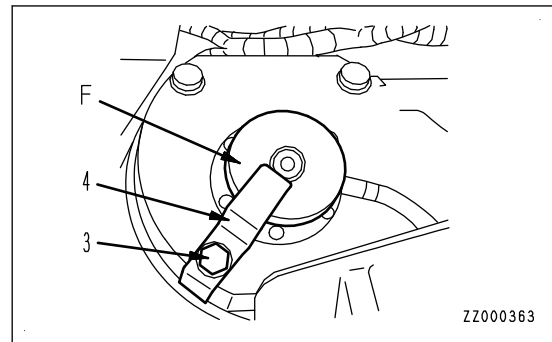
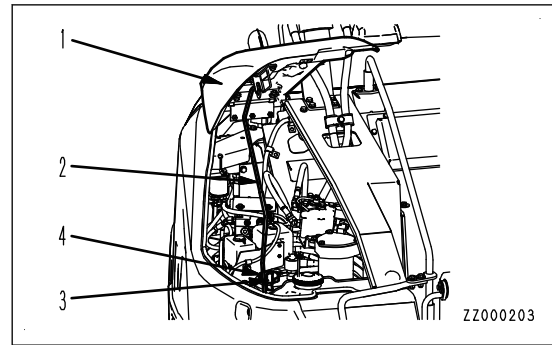

15. Remove the plugs (2 places) at the outlet and inlet.  
Be careful not to get any dirt or mud on the hose fitting.  
If O-ring is damaged, replace it with a new one.
16. Connect the hose on the attachment side.  
Check the direction of flow of the oil and be careful not to make any mistake.

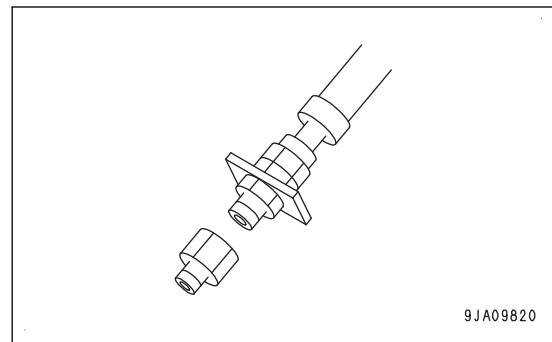

After installing the attachment, check the oil level in the hydraulic tank.

## METHOD FOR OPERATING ATTACHMENT

### ⚠ WARNING

If the travel levers or travel pedals are operated when the engine speed is decreased by the auto-deceleration function, the engine speed will suddenly increase. Be careful.

## METHOD FOR OPERATING BREAKER

### NOTICE

When performing breaker operations, use the breaker mode. If the breaker mode is not used, the breaker may be damaged. Note that you cannot operate the breaker in P, E, and L modes.

Operate the breaker operation switch.

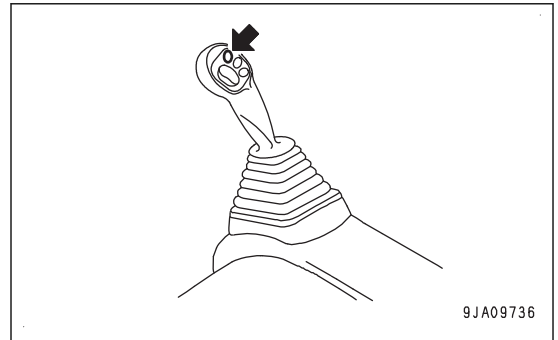

The breaker operates.

## METHOD FOR OPERATING MACHINE WHEN WORKING MODE IS NOT IN BREAKER MODE

If the breaker mode is not indicated as the working mode, enter it according to the following procedure.

1. Press working mode selector switch (1).  
The screen changes to "working mode" selection screen.

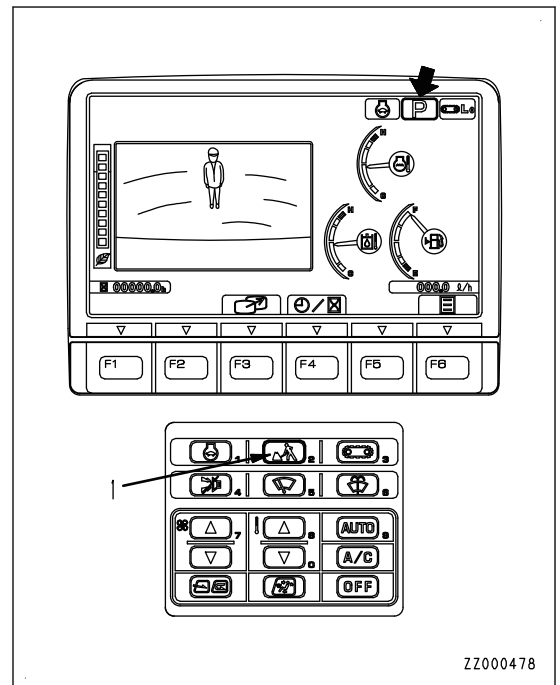

- Press working mode selector switch (1) or press switches F3 or F4 to select Breaker Mode B.

Breaker mode B is highlighted in yellow.

- With breaker mode B highlighted in yellow, enter the selection by performing either of the following operations.
  - Hold down working mode selector switch (1).
  - Press switch F6.
  - To leave as it is for 5 seconds.

#### REMARK

If you press switch F5, the screen returns to "Working Mode" selection screen without changing to the breaker mode.

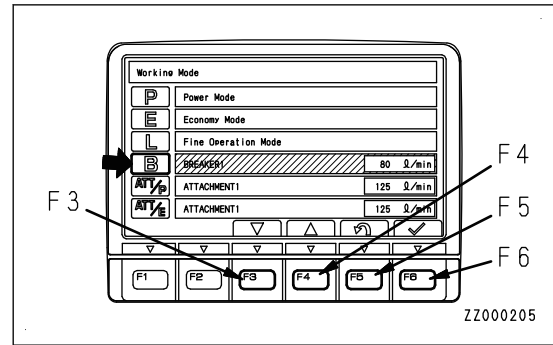

### CHECK POINTS WHEN USING BREAKER

- Is the working mode set to B mode?
- Is the selector valve in the dirt cover set to the position for the breaker?
- Is lock bar (2) for the selector valve in the dirt cover installed to the position for the breaker?

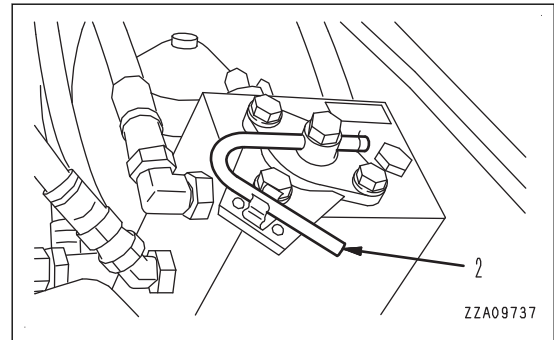

- Do you replace the hydraulic oil and its filter element at intervals shorter than the standard? The deterioration of the hydraulic oil when using the breaker is much faster than in the normal operations, so check the maintenance time with "MAINTENANCE INTERVAL FOR HYDRAULIC BREAKER".

When considering whether it is necessary to install an accumulator for the attachment circuit, contact the attachment manufacturer and then decide.

When handling the breaker, follow the instruction manual from the breaker manufacturer and use the breaker correctly.

**METHOD FOR OPERATING GENERAL ATTACHMENT SUCH AS CRUSHER ETC**

Operate attachment 1 proportional switch.

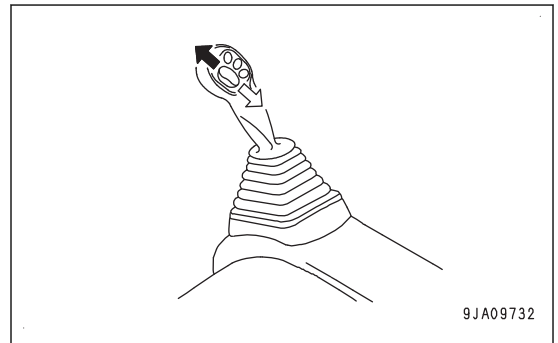

The attachment operates.

**CHECK POINTS WHEN USING GENERAL ATTACHMENT SUCH AS CRUSHER ETC**

- Is the working mode ATT/P or ATT/E?
- Is the selector valve in the dirt cover set to the position for general attachment such as crusher?
- Is lock bar (2) for the selector valve in the dirt cover installed to the position for general attachment such as crusher?

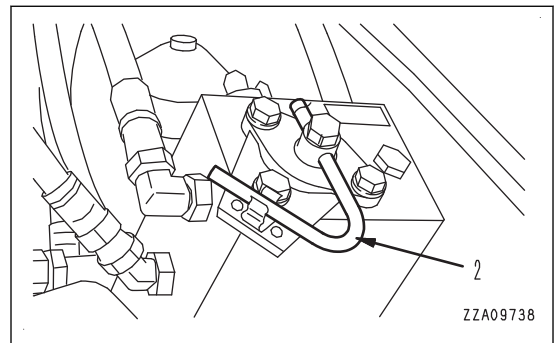

For other precautions when handling the attachment, follow the instruction manual from the attachment manufacturer and use the attachment correctly.

## LONG-TERM STORAGE

### NOTICE

**If you set the working mode to BREAKER/ATTACHMENT and operate the switch while no breaker and no general attachment are installed, the machine may overheat.**

If the equipment is not to be used for a long time, do as follows.

Set the selector valve to the position for general attachment such as crusher.

## SPECIFICATIONS

### Hydraulic specifications

#### Flow rate

Attachment mode: 125 ℓ/ min (33.0 U.S.Gal/ min)

Breaker mode: 80 ℓ/ min (21.1 U.S.Gal/ min)

#### Cracking pressure of safety valve

When breaker is used: 17.17 MPa {175 kg/cm<sup>2</sup>, 2490 PSI}

When another attachment is used: 26.51 MPa {270 kg/cm<sup>2</sup>, 3830 PSI}

# METHOD FOR CHANGING CONTROL PATTERNS (FOR MACHINES EQUIPPED WITH OPERATION PATTERN CHANGE-OVER VALVE)

## ⚠ WARNING

- When operating the machine, check that the display of the control pattern card is matched to the operation of the machine to prevent personal injury by malfunction. If it does not match, replace it immediately with the correct control pattern card.
- When checking the movement of the machine, operate slowly while paying attention to the safety around the machine.
- When changing the control pattern of the machine, stop the engine and check that the lock lever is in LOCK position.

1. Set the machine in the parking posture, stop the engine, and set the lock lever to LOCK position (L).

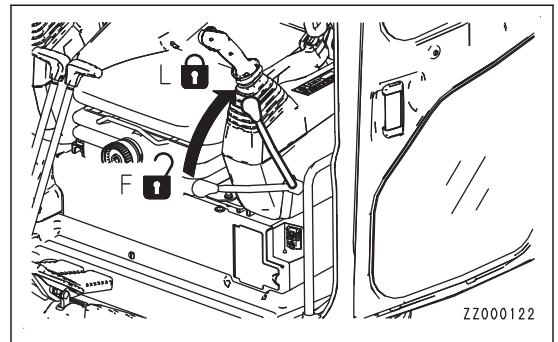

2. Open the inspection cover on the left side of the machine. If the inspection cover on the left side of the machine is opened, the changeover valve is seen.

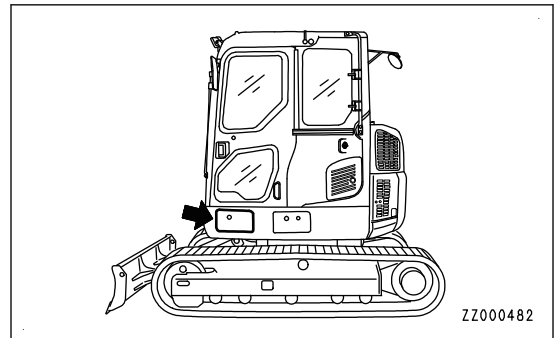

3. Loosen wing bolt (1).
4. Set lever (2) to a desired pattern by using the special tool.
  - (A): ISO pattern
  - (B): Backhoe pattern
5. After changing the control pattern, tighten wing bolt (1) securely.

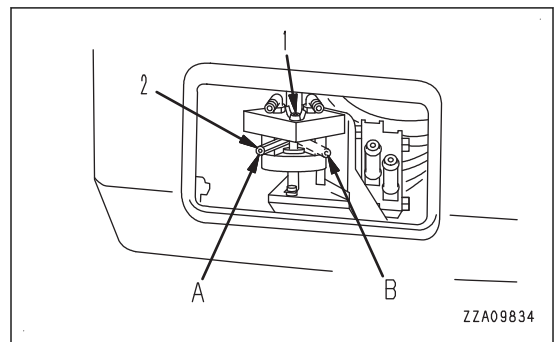

6. Replace the control pattern card (case-in type) according to the selected pattern.

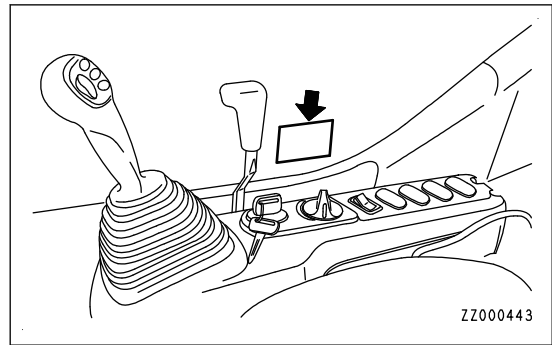

7. Start the engine and set the lock lever in FREE position.
8. Operate the work equipment control levers slowly to check that the pattern is changed.

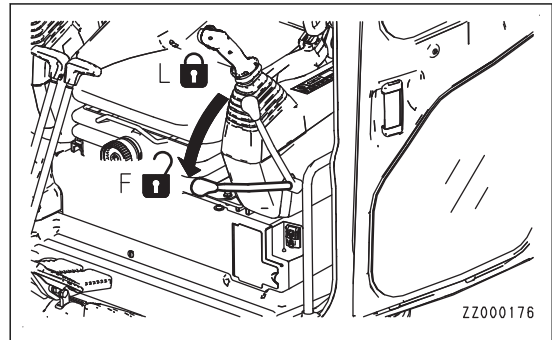

**CONTROL PATTERNS OTHER THAN STANDARD CONTROL METHOD**

**⚠ WARNING**

- When operating the machine, check that the display of the control pattern card is matched to the operation of the machine to prevent personal injury by malfunction. If it does not match, replace it immediately with the correct control pattern card.
- When checking the movement of the machine, operate slowly while paying attention to the safety around the machine.
- When changing the control pattern of the machine, stop the engine and check that the lock lever is in LOCK position.

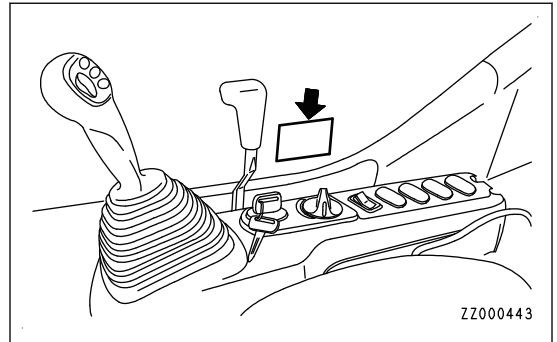

ZZ000443

**REMARK**

The control pattern cards are replaceable. If the control pattern is changed, replace the control pattern card with the one for the new control pattern.

If the pattern selector valve is installed, you can change the control pattern of the work equipment control lever as you like.

<p>ISO pattern</p> <div style="text-align: center;"> <p>ISO Pattern</p> </div> <p style="text-align: right;">9JM03955</p>	<p>Backhoe pattern</p> <div style="text-align: center;"> <p>Backhoe Pattern</p> </div> <p style="text-align: right;">9JM05886</p>
---	---



# HANDLE POWER ANGLE BLADE

Angle and lifting operation can be performed with blade control lever on power angle blade .

## BLADE CONTROL LEVER

### Lifting operation

This mode is used for lifting the blade.

(a): LOWER

(b): RAISE

N (Neutral): Blade is held at current position.

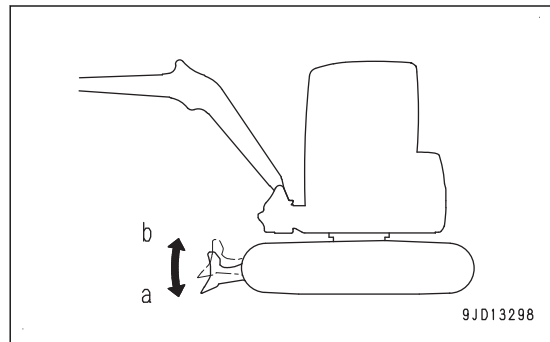
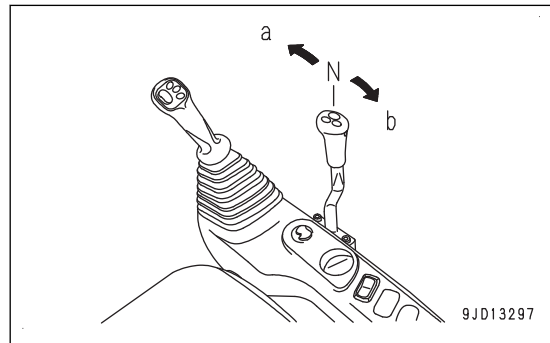

### Angling control

Set lever to N (Neutral) position, press switch (a) or (b) on the top of the knob for angle operation of the blade.

(a): Right angle

(b): Left angle

Blade moves while the switch is pressed.

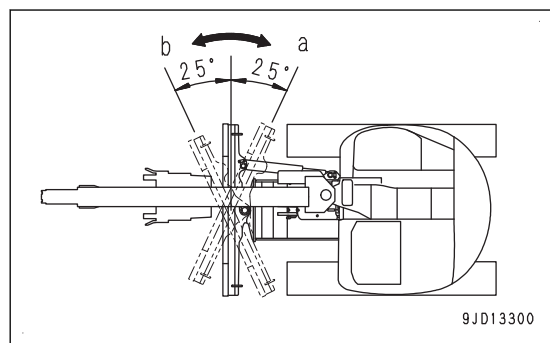
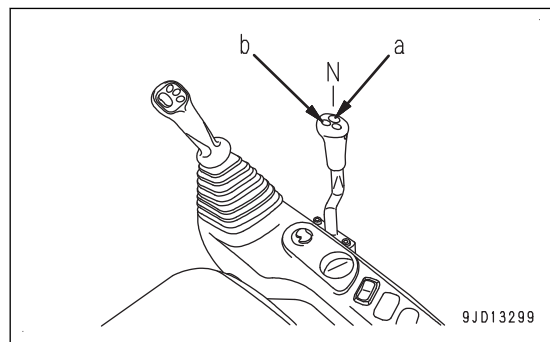

**WHEN REQUIRED****METHOD FOR LUBRICATING POWER ANGLE BLADE IN REMOVING, INSTALLING OR REPAIRING****NOTICE**

Perform lubrication when work equipment is removed, installed, and repaired.

Prepare a grease pump.

1. Pump in grease through the grease fittings shown by arrows by using a grease pump.
  - (1) Angle pin (1 place)
2. After greasing, wipe off any old grease that is pushed out.

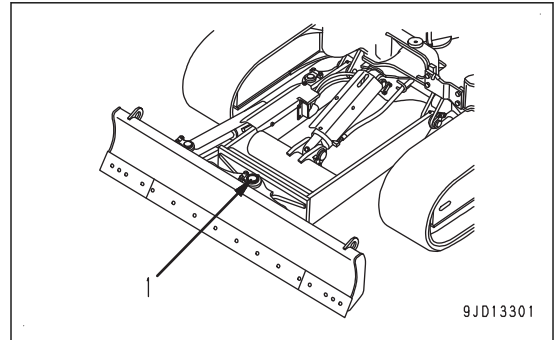
**EVERY 500 HOURS MAINTENANCE****METHOD FOR LUBRICATING POWER ANGLE BLADE****NOTICE**

- If any unusual noise is generated from any greasing point, perform greasing regardless of the greasing interval.
- Perform greasing every 10 hours for the first 50 hours of operation on a new machine.
- After the machine is subjected to digging work in the water, be sure to grease the wet pins.

Prepare a grease pump.

1. By using a grease pump, pump in grease through the grease fittings shown by arrows.
  - (1) Lift cylinder bottom pin (1 place)
  - (2) Lift cylinder rod end pin (1 place)
  - (3) Blade frame foot pin (2 places)
  - (4) Angle cylinder foot pin (1 place)
  - (5) Angle cylinder rod end pin (1 place)
  - (6) Angle pin (1 place)
2. After greasing, wipe off any old grease that is pushed out.

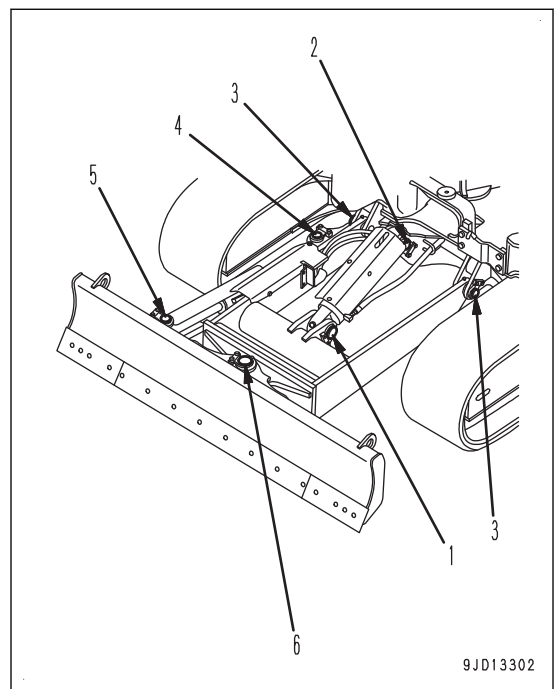

## CONSUMABLE PARTS

The parts in parentheses are to be replaced at the same time.

Item	Part No.	Part Name	Q'ty
Power angle blade	21W-71-44120	Cutting edge	1
	(02090-10845)	(Bolt)	(8)
	(02090-10813)	(Nut)	(8)
	21W-71-44131	End bit	2
	(02090-10845)	(Bolt)	(10)
	(02090-10813)	(Nut)	(10)

## SPECIFICATIONS

Item		Unit	
Blade width x height		mm {ft in}	2330 x 485 {7' 8" x 1' 7"}
Max. blade lift above ground	Road liner	mm {ft in}	650 {2' 2"}
	Steel shoe	mm {ft in}	600 {2' 0"}
Max. blade drop below ground	Road liner	mm {ft in}	470 {1' 7"}
	Steel shoe	mm {ft in}	515 {1' 8"}
Maximum angling angle		deg.	Each of right and left 25

## ATTACHMENTS AND OPTIONS

### WARNING

- Read the instruction manual for the attachment and the sections of this manual related to attachments and options.
- Installing any attachment or optional equipment is related to the safety issue. Contact your Komatsu distributor before installing.
- Installing attachments or optional equipment without consulting your Komatsu distributor may not only cause problems with safety, but may also have an adverse effect on the operation of the machine and the life of the equipment.
- Any personal injuries, product failures, physical loss or damage resulting from the use of unauthorized attachments or parts will not be the responsibility of Komatsu.

## INSTALL ATTACHMENT

### WARNING

Depending on the type or combination of work equipment, there is a danger that the work equipment may hit the cab or machine body.

When using unfamiliar work equipment for the first time, check before starting if there is any danger of interference, and operate it with care.

## Table of the combination of attachments which can be installed to the short arm and long arm

○: Can be used

△: Can be used only for light duty work

x: Cannot be used

### NOTICE

- When the long arm is equipped, if the bucket is drawn to the machine body, the arm interferes with the body. Operate the long arm carefully.
- When the boom is fully lowered during oblique digging, the boom interferes with the undercarriage. Operate the boom carefully.

## Categories of use

Select a proper attachment for each use.

For general digging: Digging or loading sand, gravel, clay etc.

For light duty digging: Digging or loading dry and loose earth and sand, mud etc.

For loading: Loading of dry and loose earth

### REMARK

For digging or loading hard soil or soft rock, the reinforced bucket having high durability and wear and abrasion resistance is recommended.

Model	Tooth mounting pin	Capacity m <sup>3</sup> (cu.yd) SAE/CECE	Opening width (Body) mm ( in)	Opening width (Side cutter) mm ( in)	Use	Short arm	Long arm
Narrow bucket	Vertical	0.09/0.08 (0.12/0.10)	350 (13.8)	450 (17.7)	Narrow digging	○	○

Model	Tooth mounting pin	Capacity m <sup>3</sup> (cu.yd) SAE/CECE	Opening width (Body) mm ( in)	Opening width (Side cutter) mm ( in)	Use	Short arm	Long arm
Narrow bucket	Vertical	0.13/0.11 (0.17/0.14)	450 (17.7)	550 (21.7)	Narrow digging	○	○
Narrow bucket	Vertical Horizontal	0.20/0.18 (0.26/0.24)	550 (21.7)	650 (25.6)	Narrow digging	○	○
Light duty bucket	Vertical Horizontal	0.28/0.25 (0.37/0.33)	650 (25.6)	750 (29.5)	General digging	○	×
Reinforced bucket	Horizontal	0.28/0.25 (0.37/0.33)	650 (25.6)	750 (29.5)	General digging	○	×
Light duty bucket	Vertical	0.34/0.30 (0.44/0.39)	760 (29.9)	-	Loading	○	×

## TRACK SHOES SELECTION

Select the appropriate track shoe to match the operating conditions.

### Track shoe selection

1. Check the ground to work in Use column of Use category table, and then check Category column.

#### Classification by use

Classification	Use	Precautions when using
A	Paved road	For protection of the road liner and rubber shoes, always observe "HANDLE ROAD LINERS AND RUBBER SHOES".
B	Rocky ground, riverbeds Normal soil	On rough ground where there are large obstacles such as boulders or fallen trees, travel at low (Lo) speed.
C	Normal soil Soft ground	This shoe cannot be used on rough ground where there are large obstacles such as boulders or fallen trees. Travel at high (Hi) speed only on a flat ground. When it is obliged to drive the machine over an obstacle, drive slowly at low (Lo) speed.

2. Check Classification column in List of shoe specifications and select a suitable shoe for the use.

#### List of shoe specifications

	Specification	Classification
Standard	450 mm {17.7 in} Road liner	A
If equipped	450 mm {17.7 in} Rubber shoe	A
If equipped	450 mm {17.7 in} Triple	B
If equipped	600 mm {23.6 in} Triple	C

### Precaution for selection track

- Since working condition "C" is for wide shoe, its use is limited.  
Check the precautions for use and the using condition, and then use a suitable shoe.
- When selecting the shoe width, choose the narrowest shoes possible to bring the machine within the range where there is no problem regarding the machine flotation and ground contact pressure.  
If wider shoes than necessary are used, the load on the shoe will increase. It may cause problems such as bending of the shoe, cracking of the link, damage of the pin, and looseness of the shoe bolts.

## RECOMMENDED ATTACHMENT OPERATIONS

The following descriptions are the precautions which must be followed when operating the hydraulic excavator equipped with an attachment.

### NOTICE

Select the optimum attachment model for the hydraulic excavator body.

The attachments and models ready for installation differ according to the machine body. For details of the selection of the attachments or the models, consult your Komatsu distributor.

## HYDRAULIC BREAKER

### Applicable work

Major works suitable to the hydraulic breaker are as follows.

- Demolition work
- Crushing rock
- Road construction

This attachment can be used for a wide range of applications including demolition of buildings, breaking up road surfaces or slag, tunnel work, rock crushing and breaking operations in quarries.

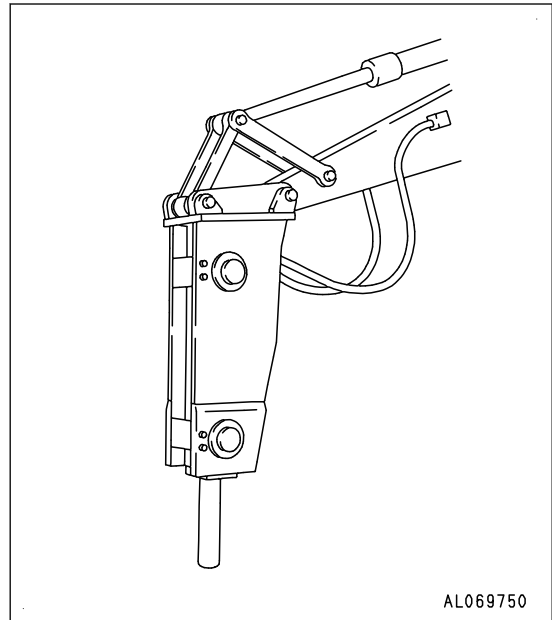

### Precautions when performing breaking operations

Keep the chisel pushed perpendicularly against the impact surface when performing breaking operations.

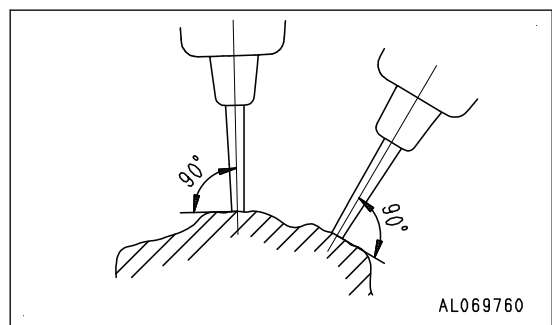

Push the chisel against the impact surface and operate so that the chassis rises approximately 5 cm {approximately 2 in} off the ground.

Do not let the machine come further off the ground than this amount.

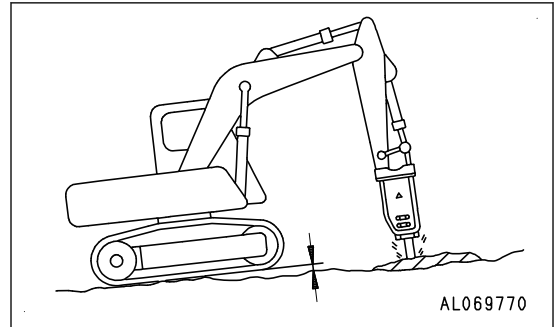

When the chisel does not penetrate or break the surface by continuous impact to the same impact surface for 1 minute, change the point of impact and perform breaking operations by scraping from the edge.

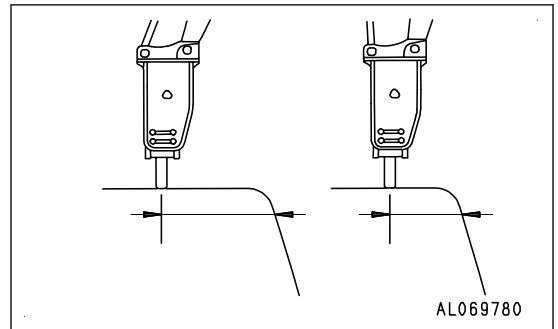

The direction of penetration of the chisel and the direction of the breaker body will gradually move out of line with each other, always adjust the bucket cylinder to keep them aligned.

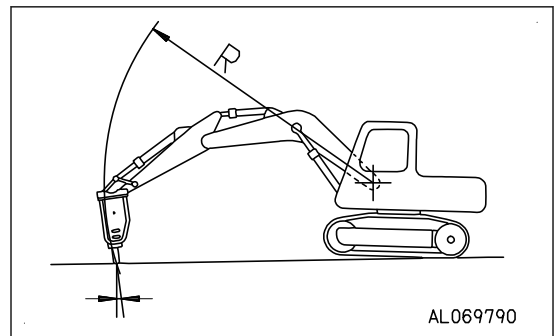

Always keep the chisel pressed against the impact surface properly not to strike at the air.

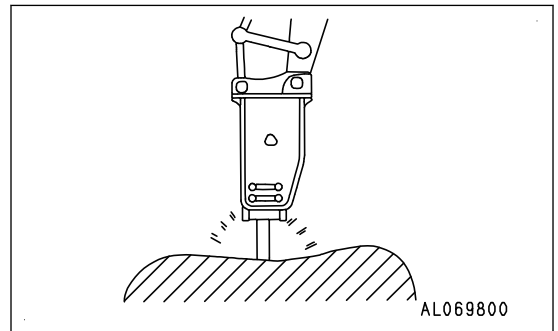

**Prohibited operations**

To ensure that the machine has a long life, and to ensure that operations are performed in safety, do not operate the machine in any of the following ways.

Do not operate all cylinders to the end of their strokes. Always leave approximately 5 cm {approximately 2 in} to spare.



Do not use the mount to gather in pieces of rock.

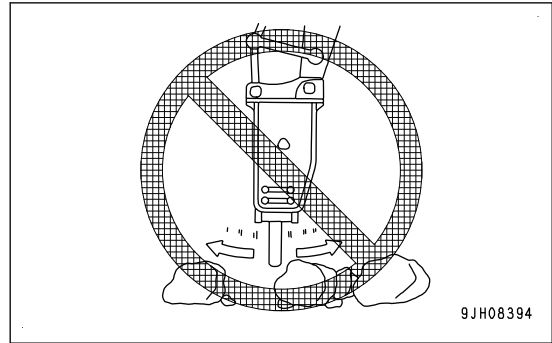

Do not work by using the swing force.

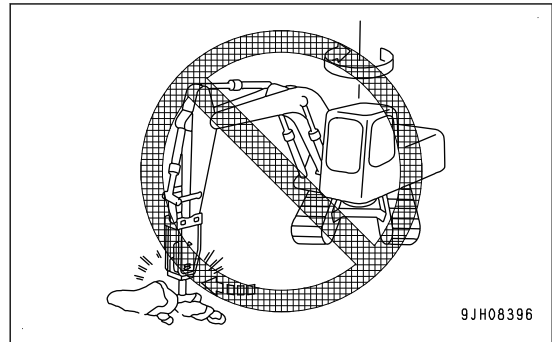

Do not move the chisel while performing breaking operation.

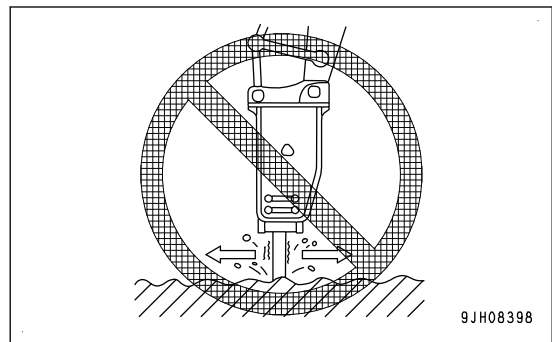

Do not perform breaker operation in horizontal or upward direction.

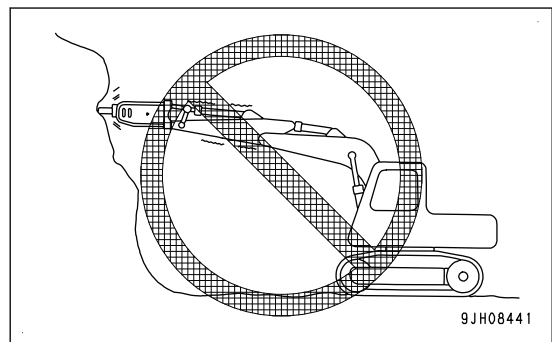

Do not work under water.

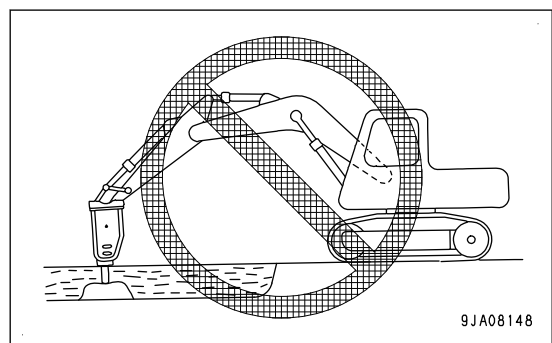

Do not pry the ground or rock with the chisel penetrated.

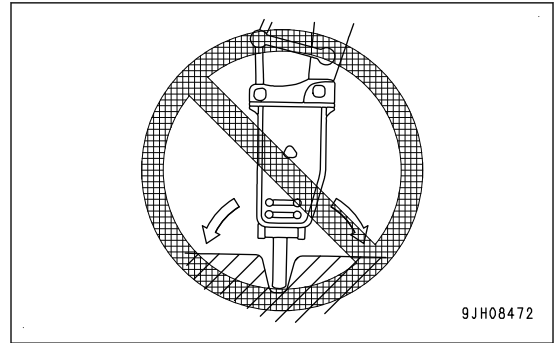

Do not perform pick work.

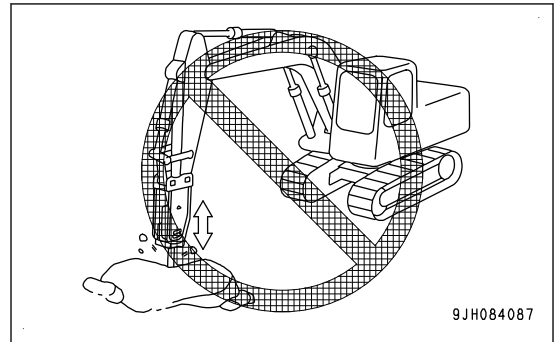

Extending the bucket cylinder rod fully and thrusting to raise the machine off the ground

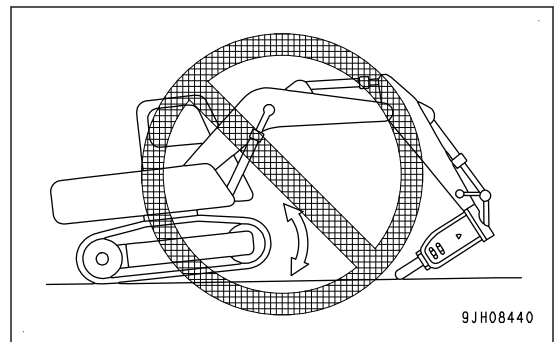

Do not perform breaker work with any cylinder at the stroke end.

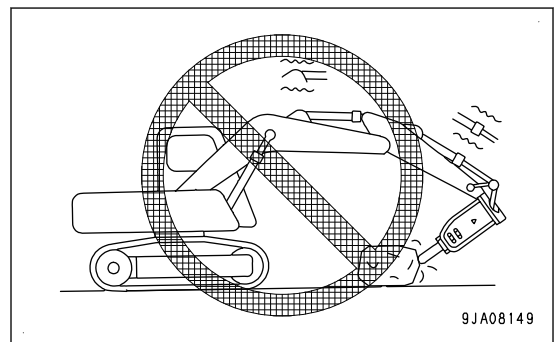

**When greasing the hydraulic breaker, set it in the specified posture.**

**NOTICE**

If the breaker is greased in an improper posture, it is filled with more grease than necessary. As a result, dirt will enter the hydraulic circuit and can damage the hydraulic components while the breaker is in use. Be sure to grease the breaker, keeping it in the right posture.

Grease the breaker while keeping it in the right posture shown below.

1. Lower the chisel to the ground perpendicularly.
2. Insert the grease pump perpendicularly to the greasing point.

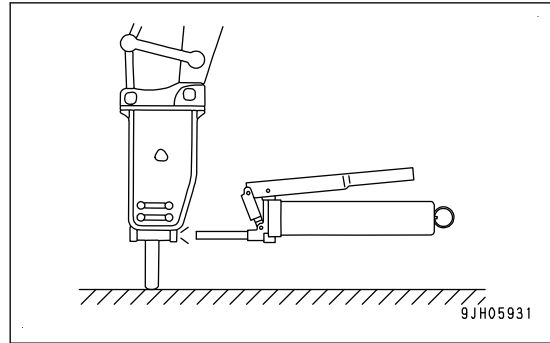

### Wrong posture

Do not perform greasing when the hydraulic breaker is lowered to the ground.

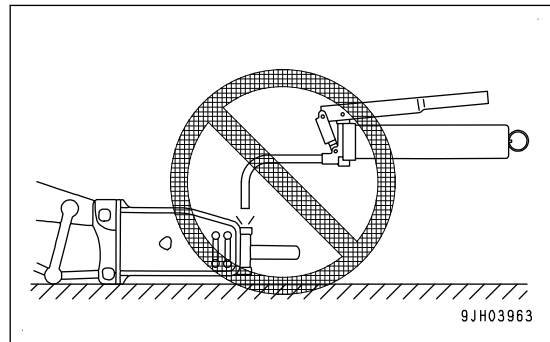

Do not perform greasing when the chisel is not lowered to the ground.

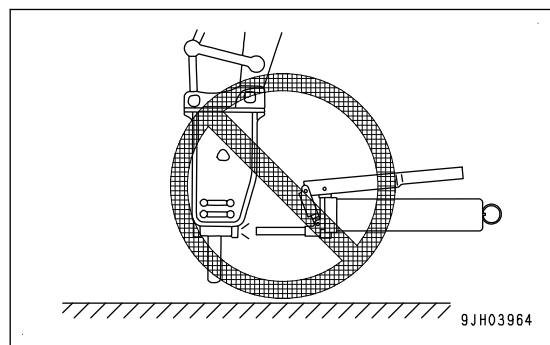

## BREAKERS

### WARNING

When the machine is used with the breaker installed, its safety decreases because the weight of the breaker is larger and the work contents of the breaker is less safe than that of the bucket.

Do not operate the machine sharply since the machine may tip over. Before working with the breaker, take protective measures from broken pieces.

### Applicable work

Major works suitable to the breaker are as follows.

- Cutting reinforcing bars and steel frames
- Demolition of concrete structures

### Prohibited operations

To ensure that the machine has a long life, and to ensure that operations are performed in safety, do not operate the machine in any of the following ways.

Do not operate all cylinders to the end of their strokes. Always leave approximately 5 cm {2 in} to spare.

Do not work with any cylinder at the stroke end.

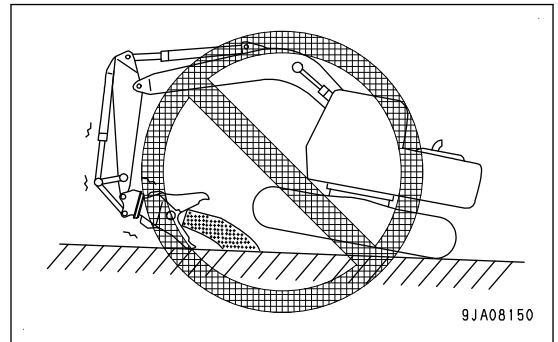

Do not work with the machine directed sideways.

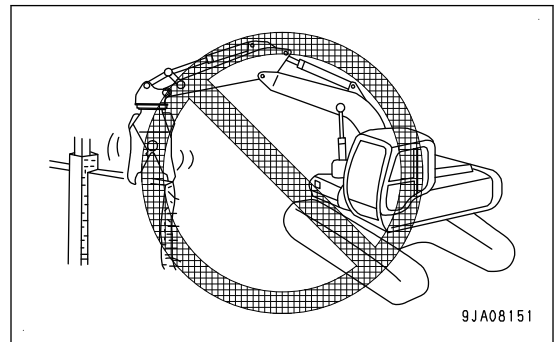

Do not drop or stop the breaker sharply.

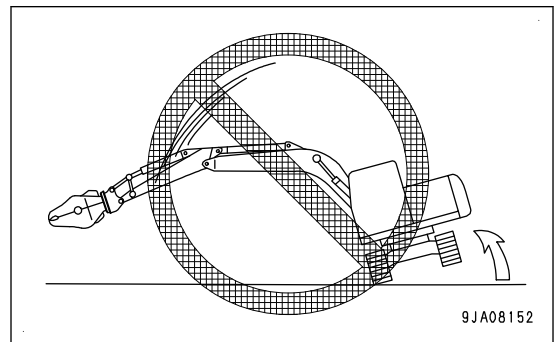

Do not perform work where broken pieces fall onto the machine.

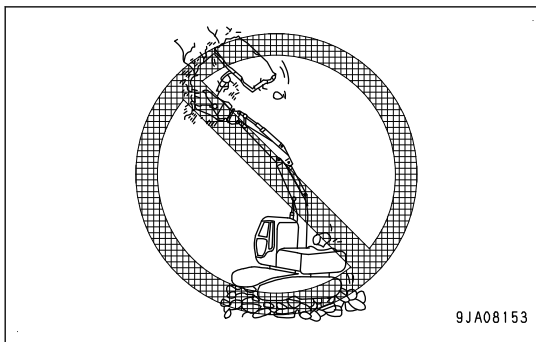

Do not work on a ground which cannot bear the machine weight or breaking impacts.

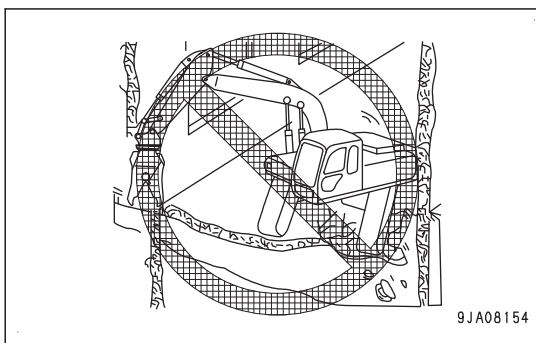

Do not perform work near the undercarriage of the machine.

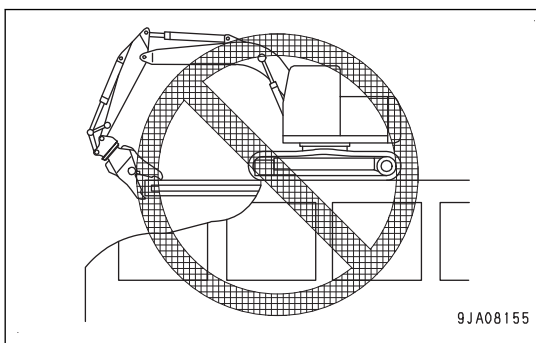

Do not work while the machine is inclined on debris, etc.

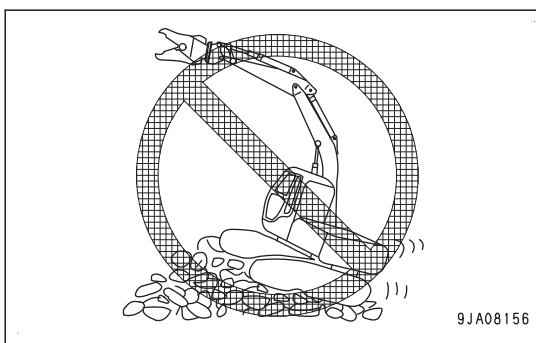

Do not work by using the swing force or dropping force.

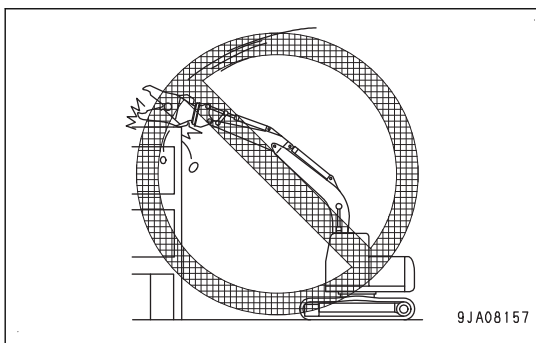

Always face the material to be broken at right angles.  
 If the breaker bites into the material diagonally, an excessive force is applied to it and the machine is damaged.

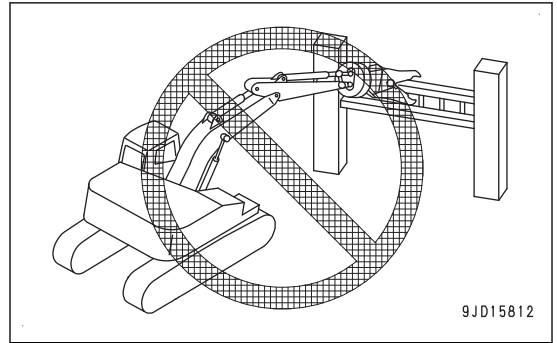

Do not extend the bucket cylinder or arm cylinder sharply.

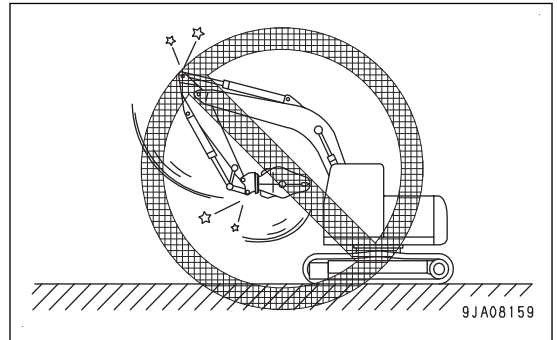

Do not raise the boom sharply.

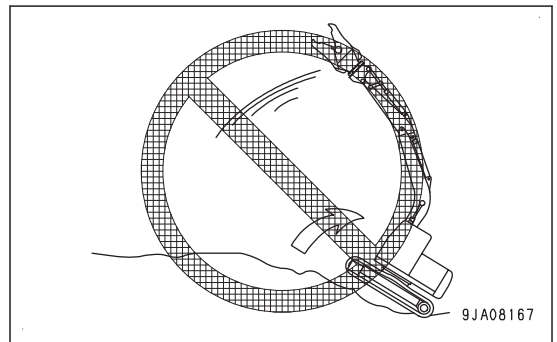

# MACHINES NOT EQUIPPED WITH REAR VIEW CAMERA

The following explanation describes the machine monitor screen on the machine without rearview camera. For items which are not explained below, see OPERATION, “EXPLANATION OF COMPONENTS”.

## MACHINE MONITOR EQUIPMENT NAME

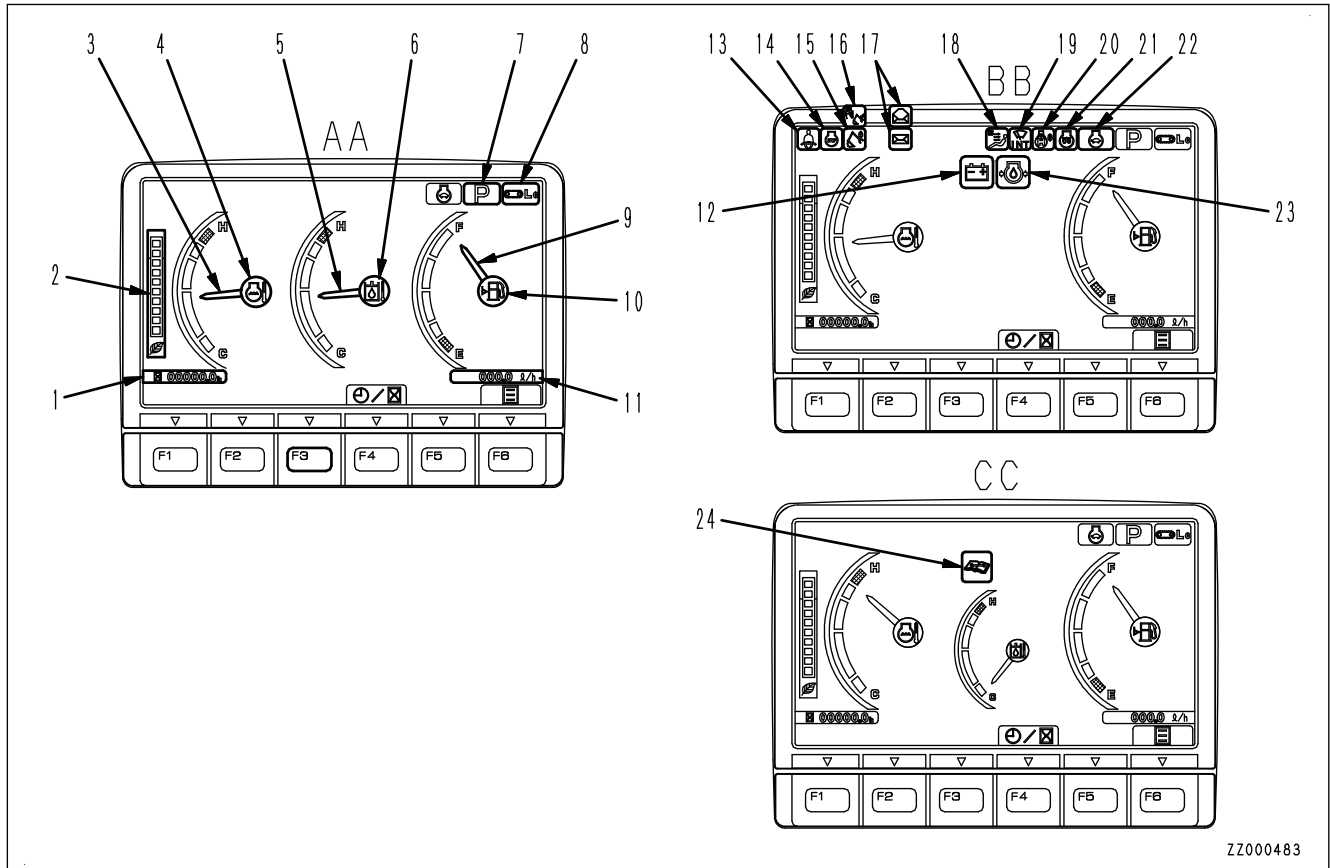

ZZ000483

AA: Standard screen, BB: Check before starting screen, CC: Maintenance time warning screen

- (1) Service meter/clock
- (2) ECO gauge
- (3) Engine coolant temperature gauge
- (4) Engine coolant temperature caution lamp
- (5) Hydraulic oil temperature gauge
- (6) Hydraulic oil temperature caution lamp
- (7) Working mode display
- (8) Travel speed display
- (9) Fuel gauge
- (10) Fuel level caution lamp
- (11) Fuel consumption gauge
- (12) Charge level caution lamp
- (13) Seat belt caution lamp
- (14) Engine stop pilot lamp
- (15) Work equipment lock pilot lamp
- (16) Lock lever automatic lock release pilot lamp
- (17) Message display
- (18) Air conditioner pilot lamp
- (19) Wiper pilot lamp
- (20) Swing lock pilot lamp
- (21) Preheating pilot lamp
- (22) Auto-deceleration pilot lamp
- (23) Engine oil pressure caution lamp
- (24) Maintenance time caution lamp

**EXPLANATION OF MACHINE MONITOR EQUIPMENT**

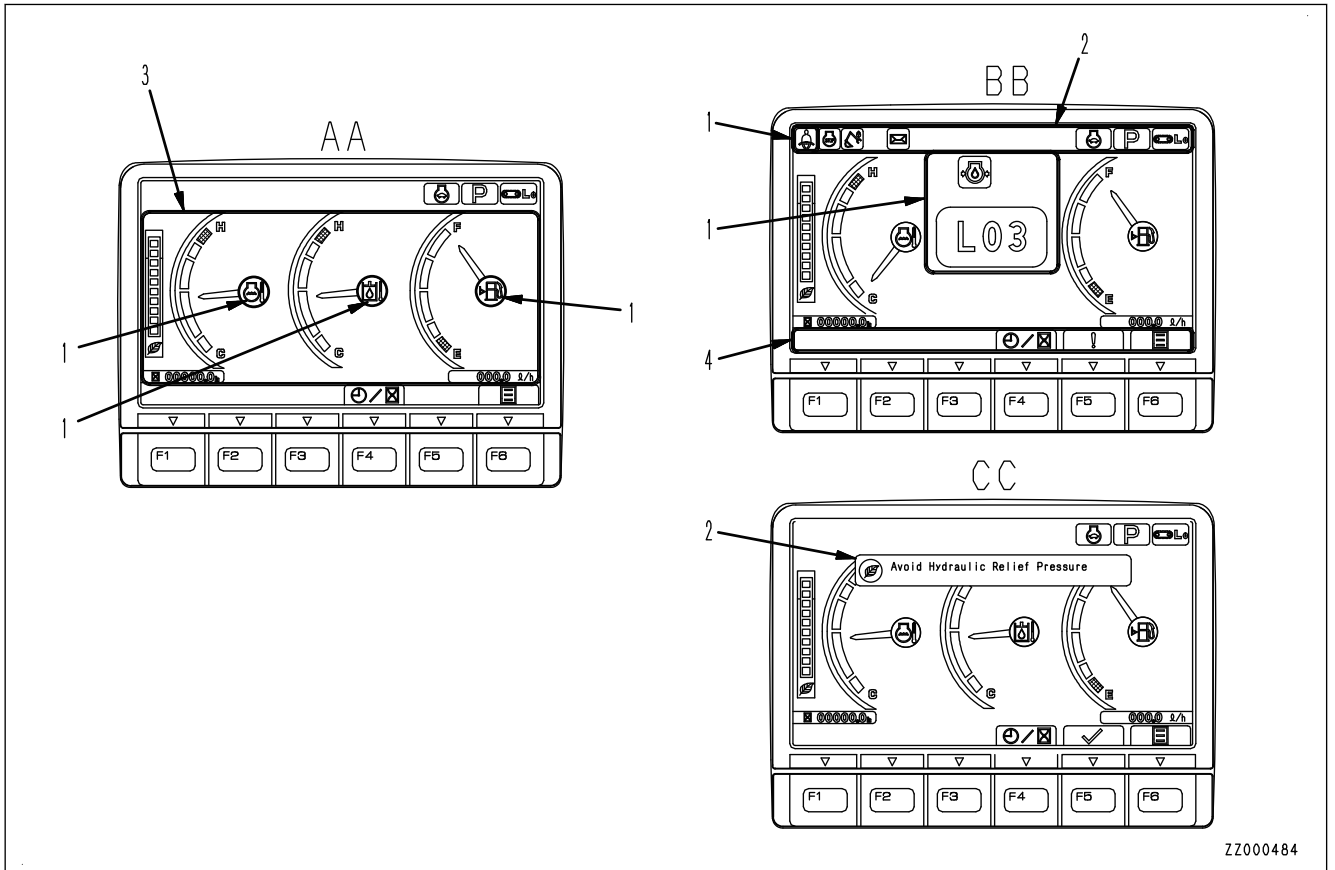

ZZ000484

AA: Standard screen, EE: Warning or Error screen, DD: Guidance screen

(1) Warning display

(3) Meter display

(2) Pilot display

(4) Guidance icon display





# REPLACEMENT PARTS

## PERIODIC REPLACEMENT OF DEFINED LIFE PARTS

For using the machine safely for an extended period of time, you must periodically replace the safety and fire prevention-related parts listed in the table of defined life parts.

Material quality of these parts can change as time passes and they are likely to wear out or deteriorate. However, it is difficult to determine the extent of wear or deterioration at the time of periodic maintenance. Hence, it is required to replace them with new ones regardless of their condition after a certain period of usage. This is important to ensure that these parts maintain their full performance at all times.

Furthermore, should anything abnormal be found on any of these parts, replace it with a new one even if the periodic replacement time for the part has not yet arrived.

If any of the hose clamps show deterioration like deformation or cracking, replace the clamps at the same time as the hoses.

Also perform the following checks with hydraulic hoses which need not to be replaced periodically. Retighten all loose hoses and replace defective hoses, as required.

When replacing hoses, always replace O-rings, gaskets, and other such parts at the same time.

Have your Komatsu distributor replace the defined life parts.

### DEFINED LIFE PARTS LIST

No.	Parts for periodic replacement		Replacement interval
1	Fuel system	Fuel hose Spill hose	Every 2 years or 4000 hours, whichever comes sooner
2	Engine lubrication system	Turbocharger lubrication hose Engine oil filter hose	
3	Work equipment hydraulic system	Main pump delivery hose Main pump LS hose Swing line hose	
		External work equipment hose <ul style="list-style-type: none"> <li>• Boom foot connection hose</li> <li>• Boom cylinder hose</li> <li>• Arm connection hose</li> <li>• Arm cylinder hose</li> <li>• Bucket cylinder hose</li> <li>• Travel line hose</li> <li>• Attachment additional line hose</li> <li>• Blade cylinder hose</li> <li>• Boom swing cylinder hose</li> </ul>	
4	Others	PPC accumulator Attachment additional accumulator	Every 3 years from start of usage or 5 years after manufacturing of seat belt, whichever comes sooner
		Seat belt	

## CONSUMABLE PARTS

Replace consumable parts such as the filter element or air cleaner element at the time of periodic maintenance or before they reach the wear limit. The consumable parts should be replaced correctly in order to ensure more economic use of the machine. When replacing parts, Komatsu recommends using Komatsu genuine parts.

As a result of our continuous efforts to improve product quality, the part number may change, so inform your Komatsu distributor of the machine serial number and check the latest part number when ordering parts.

### CONSUMABLE PARTS LIST

The parts in parentheses are to be replaced at the same time.

Item	Part No.	Part Name	Q'ty	Replacement interval
Engine oil filter	600-211-2111	Cartridge	1	Every 500 hours
Fuel prefilter	600-319-4110	Cartridge	1	
Hydraulic tank breather	421-60-35170	Element	1	
Hydraulic oil filter	22P-60-21161 (07000-12135)	Element (O-ring)	1 (1)	Every 1000 hours
Fuel main filter	600-319-3881	Cartridge	1	Every 2000 hours
KCCV filter	600-333-3900	Element	1	
Air conditioner RECIRC air filter	22B-979-2860	Filter	1	Every 1 year
Air conditioner FRESH air filter	17M-911-3530	Element	1	
Electric heater	6204-11-4850	Gasket	1	-
Air cleaner	600-185-2200	Element assembly	1	
Additional filter for breaker (if equipped)	201-973-7481 (07000-12090)	Element assembly (O-ring)	1 (1)	
Bucket	Vertical pin type			
	20X-70-23161 (203-70-43212) (203-70-43220)	Tooth (Pin) (Pin)	4 (4) (4)	
	Horizontal pin type			
	20X-70-14160 (20X-70-00100)	Tooth (Pin assembly)	4 (4)	
	Side cutter type			
	201-70-74171 201-70-74181 (21W-70-21810) (01803-02228)	Side cutter (left) Side cutter (right) (Bolt) (Nut)	1 1 (6) (6)	

# RECOMMENDED FUEL, COOLANT, AND LUBRICANT

## NOTICE

- **Komatsu genuine oils are conditioned to maintain the reliability and durability of Komatsu construction equipment and components.**  
In order to keep your machine in the best condition for long period of time, it is essential to follow the instructions in this Operation and Maintenance Manual.
- **Failure to follow these recommendations may result in shortened life or excessive wear of the engine, power train, cooling system, and/or other components.**
- **Commercially available lubricant additives may be good or bad for the machine. Komatsu does not recommend any commercially available lubricant additive.**
- **Use the oil according to the ambient temperature as recommended in the chart below.**
- **When starting the engine in temperatures below 0 °C {32 °F} , be sure to use the recommended multi-grade oil, even if the ambient temperature may become higher during the course of the day.**
- **If the machine is operated at a temperature of -20 °C {-4 °F} and below, separate devices are needed, so consult your Komatsu distributor.**

## NOTICE

The fuel used must be ultra low-sulfur diesel fuel.

To ensure good fuel consumption characteristics and exhaust gas characteristics, the engine mounted on this machine uses an electronically controlled high-pressure fuel injection device and emission gas control system. Since the high-pressure fuel injection device requires high precision parts and lubrication, if low viscosity fuel with low lubricating ability is used, its durability may drop considerably. Also, using fuel with high sulfur content may deteriorate the engine parts, inducing failures, decrease of the life and degradation in performance.

The ASTM diesel fuel recommended by Komatsu may contain 5 % or less of biofuel. The EN diesel fuel may contain 7 % or less of it. Use the fuel which is filled into the storage tank or the fuel tank of the machine as soon as possible.

When the diesel fuel is changed to the one mixed with the bio-fuel, replace the fuel prefilter cartridge and the fuel main filter cartridge with new ones.

## LUBRICATION CHART

- The lubrication chart uses symbols to show the lubrication points and types of lubricant by each lubrication interval.  
Keep this chart in the magazine box inside the cab so that the people concerned can refer it any time during lubrication.
- Even if the same symbol is used in the lubrication chart, the recommended genuine oil may differ according to the lubrication points and the ambient temperature.

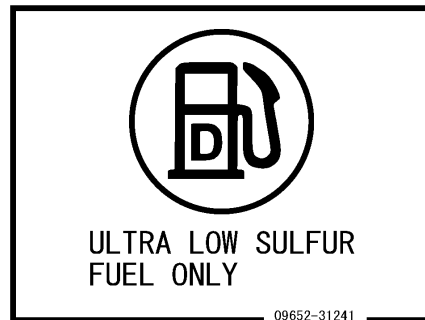

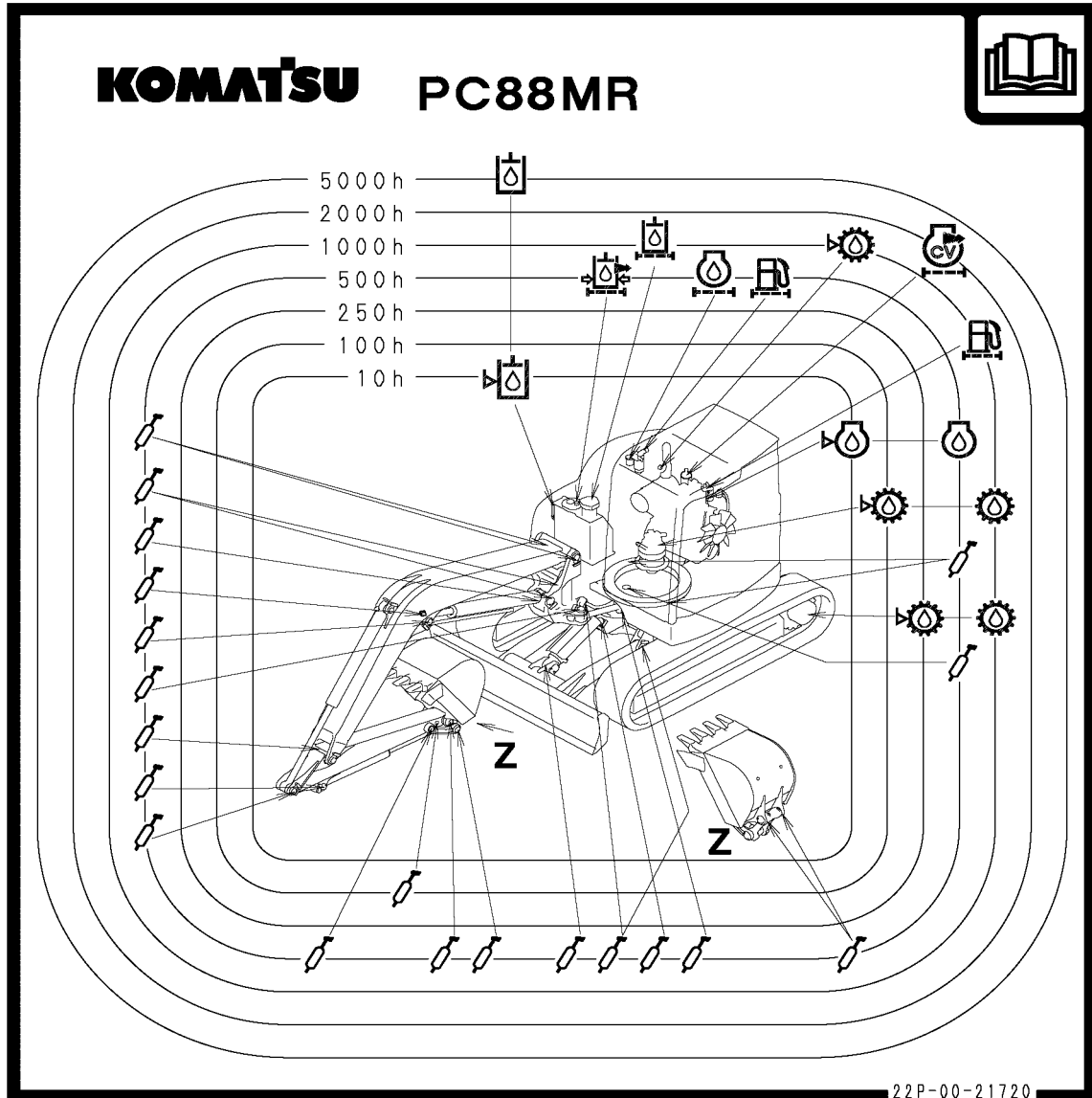

The symbols used in the lubrication chart are explained as follows.

Symbols used in the lubrication standard chart

Symbol	Meaning of symbol	Symbol	Meaning of symbol
	Read Operation and Maintenance Manual		Supply grease
	Change engine oil		Check engine oil level
	Change hydraulic oil		Check hydraulic oil level
	Change power train oil		Check power train oil level
	Replace engine oil filter		Replace hydraulic oil filter
	Replace hydraulic tank breather element		Replace fuel filter
	Replace KCCV filter		

## METHOD FOR USING FUEL, COOLANT AND LUBRICANTS ACCORDING TO AMBIENT TEMPERATURE

Reservoir	Fluid type	Recommended Komatsu Fluids	Ambient temperature			
			°C		°F	
			Min	Max	Min	Max
Engine oil pan	Engine oil for KDPF used in cold terrain (Oil Change interval 250 hours) (Note.1)	EOS5W30-LA (KES)	-25	35	-13	95
		EOS5W40-LA (KES)	-25	40	-13	104
	Engine oil for KDPF (Oil Change interval 500 hours)	EO10W30-LA (KES)	-20	40	-4	104
		EO15W40-LA (KES)	-15	50	5	122
Swing machinery Case Final drive case PTO gear case	Power train oil (Note.2)	TO30 (KES)	-30	50	-22	122
Hydraulic System	Power train oil	TO10 (KES)	-20	50	-4	122
	Hydraulic oil	HO46-HM (KES)	-20	50	-4	122
Grease fitting	Hyper grease (Note.3)	G2-TE (KES)	-20	50	-4	122
	Lithium EP grease	G2-LI (KES)	-20	50	-4	122
Cooling system	Non-Amine Engine Coolant AF-NAC (Note.4)	AF-NAC (KES)	-30	50	-22	122
Fuel tank	Diesel fuel	ASTM D975 No. 1-D S15	-30	20	-22	68
		ASTM D975 No. 2-D S15	0	50	32	122

KES: Komatsu Engineering Standard

ASTM: American Society of Testing and Material

Reservoir	Specified capacity		Refill capacity	
	Liter	US gal	Liter	US gal
Engine oil pan	12.5	3.3	11.5	3.04
Swing machinery case	2.8	0.74	2.8	0.74
Final drive case (each)	1.1	0.29	1.1	0.29
PTO gear case	0.4	0.11	0.4	0.11
Hydraulic system	100	26.4	56	14.8
Cooling system	13	3.43	-	-
Fuel Tank	125	33	-	-

### REMARK

Specified capacity means the total amount of oil including the oil in the tank and the piping. Refill capacity means the amount of oil needed to refill the system during inspection and maintenance.

Note 1: KDPF engine oil for cold district is deteriorated easily than that for normal area (replace every 500 hours), so replace oil and filter cartridge every 250 hours. For changing the maintenance time of machine monitor, ask your Komatsu distributor to perform the work.

Note 2: Power train oil has different properties from engine oil. Be sure to use the recommended oils.

Note 3: Hyper grease (G2-TE) has a high performance. When it is necessary to improve the lubricating ability of the grease in order to prevent squeaking of pins and bushings, the use of G2-TE is recommended.

Note 4: Non-Amine Engine Coolant (AF-NAC)

1. The coolant has the important function of preventing corrosion as well as preventing freezing.

Even in the areas where freezing is not an issue, the use of coolant is essential.

Komatsu recommends the use of Non-Amine Engine Coolant (AF-NAC). If you use another coolant, it may cause serious problems in the cooling system, including the engine.

Komatsu machines are supplied with Non-Amine Engine Coolant (AF-NAC). Non-Amine Engine Coolant (AF-NAC) has excellent anti-corrosion, antifreeze and cooling properties and can be used continuously for 2 years or 4000 hours.

Non-Amine Engine Coolant (AF-NAC) is strongly recommended wherever available.

2. For the density of Non-Amine Engine Coolant (AF-NAC), see "Coolant density table".

Non-Amine Engine Coolant (AF-NAC) is supplied already diluted. In this case, fill up the tank with pre-diluted fluid. (Never dilute the Non-Amine Engine Coolant with ordinary water.)

#### Coolant density table

Min. atmospheric temperature	°C	-10 or more	-15	-20	-25	-30	-35	-40	-45	-50
	°F	14 or more	5	-4	-13	-22	-31	-40	-49	-58
Density ( %)		30	36	41	46	50	54	58	61	64

## RECOMMENDED BRANDS AND QUALITIES OTHER THAN KOMATSU GENUINE OILS

When using commercially available oils other than Komatsu genuine oil, consult your Komatsu distributor.





## INDEX

## Symbols

12H/24H display mode - Switch.....	3-74
1st-line attachment proportional switch.....	3-83
2nd-line attachment proportional switch.....	3-84

## A

Accumulator (low pressure).....	6-6
Accumulator for control circuit - Check / Release nitrogen gas pressure.....	4-83
Accumulator for control circuit - Replace.....	4-92
Action level display.....	3-19
Actions if fire occurs.....	2-16
Actions when running out of fuel.....	3-228
Additional filter element for breaker - Replace.....	4-45
Additional filter for breaker.....	6-6
After cold weather season.....	3-225
After finishing work - Check.....	3-182
Air cleaner - Check / Clean / Replace.....	4-13
Air conditioner - Check / Maintenance.....	4-41
Air conditioner - Handle.....	3-192
Air conditioner - Operate.....	3-198
Air conditioner compressor belt tension - Check / Adjust.....	4-60
Air conditioner fresh/recirc air filter - Clean.....	4-73
Air conditioner pilot lamp.....	3-30
Air conditioner switch.....	3-46,3-197
Air conditioner system caution lamp.....	3-26
Alternator and starting motor - Check.....	4-86
Always use clean washer fluid.....	4-2
Antenna - Stow.....	3-210
Appoint leader when working with others.....	2-37
Ashtray.....	3-103
Attachment - Install.....	6-10
Attachment - Operate.....	6-13
Attachment - Remove.....	6-8
Attachment - Remove / Install.....	6-8
Attachment - Set.....	3-64
Attachments and options.....	6-23
Auto idle stop timer - Set.....	3-66
Auto switch.....	3-196
Auto-deceleration pilot lamp.....	3-30
Auto-deceleration switch.....	3-42
Automatic operation - Start.....	3-198
Automatic operation - Stop.....	3-199
Automatic warm-up operation - Cancel.....	3-147
AUX.....	3-207
Avoid mixing oil.....	4-3

## B

Backhoe work.....	3-176
Band/AUX selector button.....	3-205
Basic operation of machine monitor.....	3-10

Basic operation of machine monitor when starting engine in abnormal situation.....	3-14
Basic operation of machine monitor when starting engine in normal situation.....	3-10
Basic operation of machine monitor when starting engine while engine shutdown secondary switch is ON.....	3-11
Basic operation of machine monitor when stopping engine in normal situation.....	3-11
Basic operation of machine monitor when trouble occurs while operating machine.....	3-16
Battery - Handle.....	2-40
Battery - Install.....	3-233
Battery - Remove.....	3-232
Battery - Remove / Install.....	3-232
Battery disconnect switch.....	3-110
Battery electrolyte level - Check.....	4-57
Battery inspection cover - Lock.....	3-189
Battery inspection cover - Open.....	3-189
Battery inspection cover - Open / Close.....	3-189
Beware of asbestos dust.....	2-24
Blade control lever.....	3-91,6-20
Boom swing control pedal.....	3-92
Breaker - Operate.....	6-13
Breaker - Set.....	3-62
Breaker operation switch.....	3-84,6-6
Breakers.....	6-31
Bucket - Replace / Invert.....	3-178
Bucket clearance - Adjust.....	4-39
Bucket tooth (horizontal pin type) - Replace.....	4-37
Bucket tooth (vertical pin type) - Replace.....	4-34
Buzzer cancel switch.....	3-45

## C

Cab door - Lock / Unlock.....	3-191
Cab equipment names.....	3-4
Cab front window - Open / Close.....	3-94
Calendar - Set.....	3-72
Camera image selector switch.....	3-47
Caution lamp for sudden engine stop by automatic idle stop.....	3-25
Caution lamp list.....	3-20
Ceiling window - Open / Close.....	3-94
Charge level caution lamp.....	3-26
Check drained oil and used filter.....	4-2
Check points when using breaker.....	6-14
Check points when using general attachment such as crusher etc.....	6-15
Check service meter reading.....	4-2
Check signs and signalman's signals.....	2-24
Checks after inspection and maintenance.....	4-3
Checks and adjustment before starting engine.....	2-25,3-116
Checks before starting.....	2-26,4-53
Cigarette lighter.....	3-83

Clock - Adjust.....3-71,3-210  
 Cold weather operation.....3-224  
 Cold weather operation information.....3-224  
 Comparison of road liners, rubber shoes and steel shoes.....3-211  
 Consumable parts.....6-22,7-3  
 Consumable parts list.....7-3  
 Contents of safety labels.....2-5  
 Control levers and pedals.....3-89  
 Control patterns other than standard control method...  
 .....6-19  
 Controller.....3-108  
 Controls and gauges names.....3-5  
 Coolant - Check level / Add.....3-124  
 Coolant and water for dilution.....4-5  
 Cooling system - Clean inside.....4-18  
 Cover with lock.....3-102  
 Cover with lock - Lock.....3-184  
 Cover with lock - Open.....3-184  
 Cover with lock - Open / Close.....3-184  
 Cup holder.....3-102  
 Current abnormality display switch.....3-22

## D

Daylight saving time - Set.....3-74  
 Defined life parts list.....4-91,7-2  
 Defroster - Operate.....3-203  
 Digging work.....3-176  
 Directions of machine.....1-4  
 Dirt cover - Lock.....3-188  
 Dirt cover - Open.....3-187  
 Dirt cover - Open / Close.....3-187  
 Display.....3-206  
 Display monitor.....3-196  
 Display selector button.....3-206  
 Display setting - Change.....3-56  
 Display warning tag during inspection and maintenance.....2-37  
 Displaynon-display of ECO gauge - Switch.....3-58  
 Displaynon-display of ECO guidance - Switch.....3-59  
 Displaynon-display of guidance when key is OFF - Switch.....3-60  
 Ditching work.....3-176  
 Do not disassemble recoil spring.....2-44  
 Do not drop things inside machine.....4-2  
 Do not get caught in work equipment.....2-19  
 Do not go close to high-voltage cables.....2-23  
 Do not perform lifting operations.....3-169  
 Do not travel long time continuously.....3-170  
 Dust indicator - Check.....3-119  
 Dusty jobsite.....4-3

## E

ECO gauge.....3-37  
 ECO gauge - Set target fuel consumption value...3-58  
 ECO guidance.....3-32

ECO guidance record - Check.....3-53  
 Economy mode - Adjust.....3-61  
 Electric wiring - Check.....3-126  
 Electrical system - Phenomena and actions.....3-237  
 Emergency escape hammer.....3-101  
 Emergency exit from operator's cab.....2-19  
 Energy saving guidance.....3-53  
 Engine - Check low-speed run and acceleration 3-145  
 Engine - Check starting condition and unusual noise..  
 .....3-144  
 Engine - Operate / Check after starting.....3-144  
 Engine - Operate/checks before starting.....3-137  
 Engine - Start.....3-139  
 Engine - Start in cold weather.....3-141  
 Engine - Start in normal weather.....3-139  
 Engine - Start with booster cables.....3-235  
 Engine - Stop.....3-155  
 Engine - Warm-up operation.....3-146  
 Engine coolant temperature caution lamp.....3-23  
 Engine coolant temperature gauge.....3-34  
 Engine high-pressure piping clamp - Check for looseness and hardening of rubber.....4-93  
 Engine hood - Lock.....3-186  
 Engine hood - Open.....3-185  
 Engine hood - Open / Close.....3-185  
 Engine intake pipe clamps - Check all tightening points.....4-82  
 Engine oil pan - Change oil / Engine oil filter cartridge - Replace.....4-65  
 Engine oil pan - Check oil level / Add oil.....3-125  
 Engine oil pressure caution lamp.....3-26  
 Engine shutdown secondary switch.....3-87  
 Engine stop pilot lamp.....3-31  
 Engine system caution lamp.....3-25  
 Engine valve clearance - Check / Adjust.....4-86  
 Ensure good visibility.....2-23  
 Ensuring safe operation.....2-14  
 Every 100 hours maintenance.....4-54  
 Every 1000 hours maintenance.....4-75  
 Every 2000 hours maintenance.....4-83  
 Every 250 hours maintenance.....4-56  
 Every 4000 hours maintenance.....4-91  
 Every 500 hours maintenance.....4-62,6-21  
 Every 5000 hours maintenance.....4-94  
 Explanation of air conditioner equipment.....3-193  
 Explanation of components.....3-8,6-5  
 Explanation of equipment on quick coupler.....3-112  
 Explanation of machine monitor equipment...3-8,6-35  
 Explanation of radio equipment.....3-205

## F

Fan belt tension - Check / Replace.....4-82  
 Fan switch.....3-194  
 Filter.....4-7  
 Final drive case - Change oil.....4-78  
 Final drive case - Check oil level / Add oil.....4-56  
 Fire extinguisher.....3-109

Frequency - Adjust..... 3-208  
 Frequency - Auto-preset..... 3-208  
 Fresh and clean lubricants..... 4-2  
 FRESH/RECIRC air selector switch..... 3-196  
 Fuel..... 4-4  
 Fuel - Check level / Add..... 3-127  
 Fuel and lubricants to match the ambient temperature  
 ..... 4-3  
 Fuel circuit - Bleed air..... 3-228  
 Fuel consumption gauge..... 3-37  
 Fuel consumption gauge - Set display..... 3-56  
 Fuel consumption record - Check..... 3-54  
 Fuel control dial..... 3-83  
 Fuel gauge..... 3-35  
 Fuel level caution lamp..... 3-24  
 Fuel main filter cartridge - Replace..... 4-80  
 Fuel prefilter cartridge - Replace..... 4-67  
 Fuel spray prevention cap - check for missing and  
 hardening of rubber..... 4-93  
 Fuel tank - Drain water and sediment..... 3-118  
 Function switches..... 3-47  
 Function switches and guidance icons..... 3-38  
 Fuse..... 3-106  
 Fusible link..... 3-107

**G**

Gas spring - Check..... 4-49  
 General attachment such as crusher - Operate... 6-15  
 General precautions..... 6-2  
 General precautions common to operation and main-  
 tenance..... 2-14  
 General view..... 3-2  
 GPS synchronization - Set..... 3-72  
 Grease..... 4-5  
 Grease pump holder..... 3-109  
 Ground whole the bottom side of blade to support  
 machine..... 3-170

**H**

Handle electrical components..... 4-7  
 Handling bucket with hook..... 6-4  
 Handling quick coupler..... 3-111  
 High register range (treble) - Adjust..... 3-209  
 High-pressure hoses and pipings - Handle..... 2-43  
 Horn - Check..... 3-128  
 Horn switch..... 3-84  
 Hydraulic breaker..... 6-26  
 Hydraulic circuit..... 6-7  
 Hydraulic circuit - Bleed air..... 4-3,4-50  
 Hydraulic circuit - Connect..... 6-7  
 Hydraulic oil filter element - Replace..... 4-75  
 Hydraulic oil temperature caution lamp..... 3-23  
 Hydraulic oil temperature gauge..... 3-35  
 Hydraulic system - Warm-up operation..... 3-148  
 Hydraulic system caution lamp..... 3-24  
 Hydraulic tank - Change oil..... 4-94

Hydraulic tank - Check oil level / Add oil..... 3-122  
 Hydraulic tank breather element - Replace..... 4-74

**I**

If any problem is found..... 2-15  
 If machine monitor shows warning display..... 3-242  
 Inside operator's compartment..... 2-15  
 Inspecting machine..... 2-14  
 Install attachment..... 6-23  
 Introduction..... 1-4  
 Investigate and confirm jobsite conditions..... 2-22

**K**

KCCV filter element - Replace..... 4-87  
 Keep machine clean..... 2-15  
 Keep work place clean and tidy..... 2-37  
 Komatsu Closed Crankcase Ventilation (KCCV). 3-114  
 Komatsu genuine lubricants..... 4-2  
 Komatsu genuine replacement parts..... 4-2  
 KOMTRAX..... 3-115

**L**

Lamp switch..... 3-84  
 Language settings..... 3-75  
 Left front mirror - Adjust..... 3-132  
 Leveling work..... 3-177  
 Lifting operation by using bucket with hook..... 2-36  
 Loading and unloading with trailer..... 3-216  
 Loading work..... 3-177  
 Location of engine serial No. plate..... 1-6  
 Location of product identification number (PIN)/  
 machine product identification number..... 1-6  
 Location of safety labels..... 2-3  
 Lock..... 3-183  
 Lock inspection cover..... 4-3  
 Lock lever..... 3-89  
 Lock lever automatic lock cancel pilot lamp..... 3-31  
 Lock lever automatic lock release switch..... 3-86  
 Long-term storage..... 6-16  
 Low register range (bass) - Adjust..... 3-210  
 Lubrication chart..... 7-4

**M**

Machine - Check walk-around..... 3-116  
 Machine - Escape from mud..... 3-175  
 Machine - Lift..... 3-222  
 Machine - Load..... 3-217  
 Machine - Operate when working mode is not in  
 breaker mode..... 6-13  
 Machine - Park..... 3-181  
 Machine - Running-in the new machine..... 3-145  
 Machine - Set at angle..... 4-47  
 Machine - Start (Travel forward and reverse) / Stop...  
 ..... 3-156  
 Machine - Start after long-term storage..... 3-227

Machine - Steer (Change the direction).....	3-160
Machine - Stop.....	3-159
Machine - Swing.....	3-162
Machine - Travel forward.....	3-157
Machine - Travel reverse.....	3-158
Machine - Unload.....	3-220
Machine - Warm-up operation.....	3-153
Machine equipment name.....	3-2
Machine monitor - Operate when operator identification function is available with skip.....	3-76
Machine monitor - Operate when operator identification function is available without skip.....	3-78
Machine monitor - Operate when starting switch is ON while operator ID input is set.....	3-12
Machine monitor equipment name.....	3-6,6-34
Machine operations and controls.....	3-116
Machine ready for installation of attachment - Handle.....	6-5
Machine settings.....	3-61
Machines not equipped with rear view camera.....	6-34
Magazine box.....	3-102
Main use of machine.....	1-4
Maintenance during long-term storage.....	3-226
Maintenance interval for hydraulic breaker.....	4-11
Maintenance interval when diesel fuel mixed with bio-fuel is used.....	4-12
Maintenance of air conditioner.....	2-44
Maintenance procedure.....	4-13
Maintenance schedule.....	4-10
Maintenance schedule table.....	4-10
Maintenance screen - Set.....	3-68
Maintenance time caution lamp.....	3-26
Manual operation - Start.....	3-200
Manual operation - Stop.....	3-201
Message - Check.....	3-80
Message - Reply.....	3-80
Message display.....	3-31,3-79
Meter display.....	3-34
Method for adjusting.....	3-129
Method for checking before starting.....	3-118
Method for lubricating.....	4-62
Method for steering machine.....	3-160
Mirrors - Adjust.....	3-132
Monitor settings.....	3-70
Monitor switches.....	3-38

**N**

No jumping on or off machine.....	2-18
No people on attachments.....	2-18

**O**

OFF switch.....	3-193
Oil.....	4-4
Oil / Fuel / Coolant - Handle / Perform oil clinic.....	4-4
Only authorized personnel.....	2-37
Operating record - Check.....	3-53

Operation pattern change-over valve - Change control patterns.....	6-17
Operation with cold air to face and warm air to feet - Start.....	3-202
Operator ID.....	3-76
Operator's seat - Adjust.....	3-129
Other equipment.....	3-94
Other trouble.....	3-237
Outline of maintenance.....	4-4

**P**

Perform KOWA (Komatsu Oil Wear Analysis).....	4-6
Periodic replacement of defined life parts.....	2-45,7-2
Permissible depth of water, soil and dirt.....	3-172
Phenomena and actions for chassis.....	3-239
Phenomena and actions for engine related parts.....	3-240
Phenomena that are not failures.....	3-229
Pilot display.....	3-29
Pilot display and meter display.....	3-28
Power angle blade - Handle.....	6-20
Power angle blade - Lubricate.....	6-21
Power angle blade - Lubricate in removing, installing, or repairing.....	6-21
Power button.....	3-205
Power supply for KOMTRAX.....	3-115
Power supply outlet.....	3-104
Precautions after daily work completion in cold weather.....	3-225
Precautions before starting inspection and maintenance.....	2-37
Precautions before starting operation.....	2-14
Precautions for blade position during backhoe operation.....	3-172
Precautions for charging battery.....	3-234
Precautions for check and maintenance.....	2-40
Precautions for cold weather.....	2-25
Precautions for compressed air.....	2-44
Precautions for discharged battery.....	3-231
Precautions for disposing of waste materials.....	2-45
Precautions for folding work equipment.....	3-171
Precautions for getting on or off machine.....	2-18
Precautions for high speed travel.....	3-171
Precautions for high voltage.....	2-43
Precautions for high-pressure fuel.....	2-42
Precautions for high-pressure grease when adjusting track tension.....	2-43
Precautions for high-pressure oil.....	2-42
Precautions for high-temperature coolant.....	2-41
Precautions for high-temperature oil.....	2-42
Precautions for high-temperature parts.....	2-42
Precautions for hitting blade against objects during operating blade.....	3-172
Precautions for installing, removing, or storing attachments.....	2-39
Precautions for jobsite.....	2-22
Precautions for lifting operations.....	2-36,6-4

Precautions for loading and unloading with trailer.....	3-216
Precautions for long-term storage.....	3-226
Precautions for maintenance.....	2-37,4-2
Precautions for noise.....	2-43
Precautions for operation.....	2-22,2-26,3-171,6-4
Precautions for refilling oil or fuel.....	4-2
Precautions for severe job condition.....	3-230
Precautions for towing and being towed.....	2-35
Precautions for towing machine.....	3-230
Precautions for transportation.....	2-34
Precautions for traveling.....	2-28,3-171
Precautions for traveling in forward or reverse and swinging.....	2-27
Precautions for traveling on slopes.....	2-29
Precautions for welding.....	2-40,4-2
Precautions for working at high places.....	2-39
Precautions for working on slopes.....	3-173
Precautions for working under machine or work equipment.....	2-39
Precautions related to attachments and options...	2-21
Precautions related to cab glass.....	2-21
Precautions related to protective structure.....	2-20
Precautions to prevent fire.....	2-16
Precautions when installing hydraulic hoses.....	4-3
Precautions when leaving machine.....	2-19
Precautions when loading and unloading.....	2-34
Precautions when operating on snow or frozen surfaces.....	2-32
Precautions when parking machine.....	2-32
Precautions when running engine inside building.....	2-21
Precautions when standing up from operator's seat.....	2-19
Precautions when starting engine.....	2-25
Precautions when using hammer.....	2-41
Precautions when using road liners and rubber shoes.....	3-212
Precautions when working on loose ground.....	2-22
Preheating pilot lamp.....	3-29
Preparation for long-term storage.....	3-226
Preparations for moving machine.....	3-156
Preparations for safe operation.....	2-14
Preset - Call up.....	3-208
Preset - Register.....	3-209
Preset button.....	3-206
Prevent fire.....	2-16
Product information.....	1-6
Prohibited operations.....	2-30,3-166
Prohibition of digging operation at an angle without engaging teeth.....	3-168
Prohibition of digging operation on hard rocky ground.....	3-168
Prohibition of high-speed travel operations on rough ground.....	3-170
Prohibition of operations using bucket as lever..	3-167
Prohibition of operations using bucket dropping force.....	3-167
Prohibition of operations using hydraulic cylinders to stroke end.....	3-166
Prohibition of operations using machine dropping force.....	3-167
Prohibition of operations using swing force.....	3-166
Prohibition of operations using travel force.....	3-166
Prohibition of operations when machine is not stable.....	3-168
Prohibition of sudden lever or pedal shift during high speed travel.....	3-169
Prohibition of swinging or traveling when rock is on top of track assembly.....	3-169
Protection against falling, flying or intruding objects.....	2-20
Provide fire extinguisher and first aid kit.....	2-15
PTO gear case - Check oil level / Add oil.....	4-79
Pump secondary drive switch.....	3-85
<b>Q</b>	
Quick coupler switch.....	3-88
<b>R</b>	
Radiator fin / Oil cooler fin / Air conditioner condenser fin - Check / Clean.....	4-71
Radio - Control.....	3-208
Radio - Handle.....	3-205
Read this manual.....	1-2
Rearview camera - Adjust angle.....	3-134
Recommended applications.....	3-176
Recommended attachment operations.....	6-26
Recommended brands and qualities other than komatsu genuine oils.....	7-7
Recommended fuel, coolant, and lubricant.....	7-4
Recommended use of road liners and rubber shoes.....	3-211
Refrigerant (gas) - Check level.....	4-41
Replace defined life parts.....	4-91
Right front mirror - Adjust.....	3-133
Road liner - Check.....	4-27
Road liner - Replace.....	4-27
Road liner shoe bolt - Check looseness / Tighten.....	4-24
Road liners Rubber shoes - Handle.....	3-211
Room lamp switch.....	3-85
Rubber shoes - Check.....	4-27
Rubber shoes - Install.....	4-32
Rubber shoes - Remove.....	4-31
Rubber shoes - Replace.....	4-30
Rubber shoes to steel shoes or roadliners - Change.....	4-33
Rubber shoes track tension - Check.....	4-29
Rubber shoes track tension - Check / Adjust.....	4-29
Rubber shoes track tension - Decrease / Adjust.....	4-30
Rubber shoes track tension - Increase / Adjust.....	4-29
<b>S</b>	
Safety information.....	1-3

- Safety labels..... 2-2  
 Safety rules for transporting machine..... 3-215  
 Safety-related equipment..... 2-14  
 Screen adjustment..... 3-70  
 Seat belt - Fasten / Unfasten..... 3-136  
 Seatbelt caution lamp..... 3-27  
 Select suitable place for inspection and maintenance.  
 ..... 2-37  
 Selector valve..... 6-5  
 Service item..... 4-41  
 Service meter / Clock..... 3-36  
 Service meter location..... 1-7  
 Shoes - Change..... 4-33  
 Shovel work..... 3-176  
 Side ditching work..... 3-177  
 Slide door..... 3-101  
 Slide door rail - Clean..... 4-43  
 Slide door rail and roller - Check..... 4-43  
 Slide door rail and roller - Check / Clean / Lubricate....  
 ..... 4-43  
 Slide door rail and roller - Lubricate..... 4-43  
 Slide door stopper - Check / Clean / Lubricate.... 4-44  
 Sound balance - Adjust..... 3-209  
 Sound control button..... 3-206  
 Specifications..... 5-2,6-16,6-22  
 Standard tightening torque for bolts and nuts..... 4-8  
 Start engine..... 2-24  
 Start engine with jumper cables..... 2-26  
 Starting switch..... 3-82  
 Steel shoes or roadliners to rubber shoes - Change....  
 ..... 4-33  
 Stop engine before performing inspection and main-  
 tenance..... 2-38  
 Stopper - Check clearance in opening front door is up  
 ..... 4-44  
 Store oil and fuel..... 4-6  
 Sunlight sensor..... 3-197  
 Swing circle - Lubricate..... 4-70  
 Swing lock cover..... 3-92  
 Swing lock pilot lamp..... 3-29  
 Swing machinery case - Change oil..... 4-77  
 Swing machinery case - Check oil level / Add oil.. 4-55  
 Swing parking brake cancel switch..... 3-86  
 Swing pinion - Check grease level / Add grease.. 4-70  
 Switches..... 3-81  
 System caution lamp..... 3-24  
 System operating lamp..... 3-111
- T**
- Temperature control switch..... 3-194  
 Time - Set..... 3-73  
 To pick up a new bucket or attachment..... 3-113  
 To release a bucket or attachment..... 3-112  
 Tool box..... 3-109  
 Towing and being towed..... 2-35  
 Track shoe bolt - Check looseness / Tighten..... 4-23  
 Track shoes selection..... 6-25
- Track tension - Check / Adjust..... 4-25  
 Transportation..... 3-215  
 Transportation method - Select..... 3-215  
 Travel lever..... 3-91  
 Travel speed display..... 3-30  
 Travel speed selector switch..... 3-43  
 Troubles and actions..... 3-228  
 Tuningtime adjustment button..... 3-205  
 Turbocharger protection function..... 3-143  
 Turn battery disconnect switch to off position..... 2-40  
 Two workers for maintenance when engine is running  
 ..... 2-38
- U**
- Unauthorized modification..... 2-21  
 Understanding the machine..... 2-14  
 Use handrails and steps when getting on or off ma-  
 chine..... 2-18  
 Use of fuel, coolant and lubricants according to ambi-  
 ent temperature..... 7-6  
 Use proper tools..... 2-40  
 Use warning tags..... 2-24  
 User menu..... 3-50  
 User menu display switch..... 3-50
- V**
- Vent selector switch..... 3-195  
 Visibility from operator's seat..... 1-5  
 Volume control button..... 3-205
- W**
- Warning display..... 3-17  
 Warranty of road liners and rubber shoes..... 3-211  
 Washable floor - Wash..... 4-46  
 Water pump - Check..... 4-92  
 Water separator - Check / Drain water and sediment..  
 ..... 3-120  
 Wear well-fitting clothes and protective equipment.....  
 ..... 2-14  
 When handling accumulator and gas spring..... 2-44  
 When operating on slopes..... 2-30  
 When required..... 4-13,6-21  
 Window washer fluid - Check level / Add..... 4-40  
 Window washer fluid - select..... 2-45  
 Window washer switch..... 3-45  
 Wiper pilot lamp..... 3-29  
 Wiper switch..... 3-44  
 Work equipment - Lubricate..... 4-54  
 Work equipment - Operate..... 3-162  
 Work equipment control lever..... 3-93  
 Work equipment lock pilot lamp..... 3-31  
 Working lamp - Check..... 3-128  
 Working mode..... 3-164  
 Working mode - Display..... 3-30  
 Working mode - Operate..... 3-164  
 Working mode selector switch..... 3-40

**Y**

Your machine serial numbers and distributor..... 1-7



PC88MR-10 HYDRAULIC EXCAVATOR

---

Form No. PEN01034-00

©2018 KOMATSU  
All Rights Reserved  
Printed in Japan 01-2018

---