

nifty

150T/TM42T

Operating and Safety Instructions

MODEL 150T (TM42T) SERIES

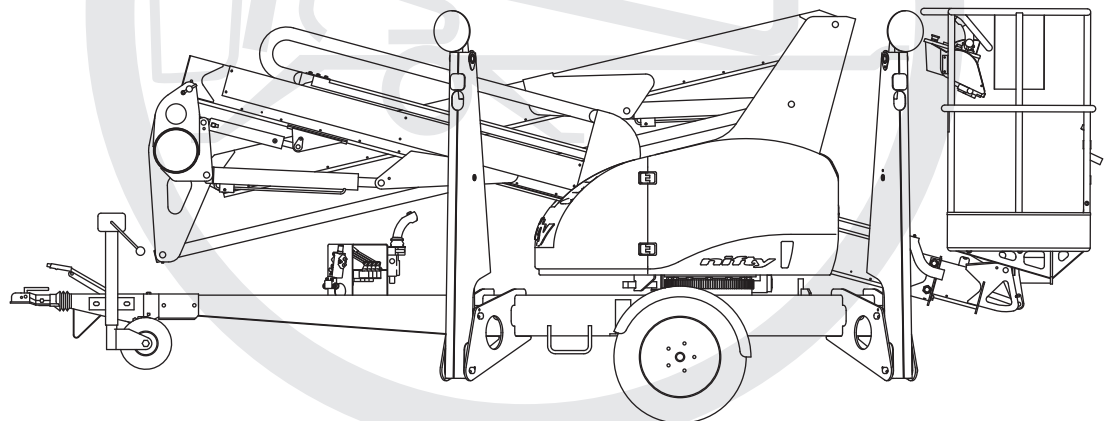

niftylift.com
info@niftylift.com

M50141/03



Niftylift Limited

Fingle Drive
Stonebridge
Milton Keynes
MK13 0ER
England

www.niftylift.com
e-mail: info@niftylift.com
Tel: +44 (0)1908 223456
Fax: +44 (0)1908 312733

Table of Contents

1	Introduction and General Information	2
1.1	FOREWORD.....	2
1.2	SCOPE	3
1.3	INTRODUCING THE 150T TRAILER MOUNT (TM) SERIES	3
1.4	GENERAL SPECIFICATION	4
1.5	IDENTIFICATION (UK PLATE)	5
2	Safety	7
2.1	MANDATORY PRECAUTIONS.....	7
2.2	ENVIRONMENTAL LIMITATIONS	10
2.3	NOISE AND VIBRATION.....	10
3	Preparation and Inspection	11
3.1	UNPACKING	11
3.2	PREPARATION FOR USE.....	11
3.3	PRE-OPERATIONAL SAFETY CHECK SCHEDULES.....	12
3.4	PLACARD, DECALS & INSTALLATION (UK).....	14
3.5	TORQUE REQUIREMENTS.....	18
4	Operation	19
4.1	CONTROL CIRCUIT COMPONENTS	19
4.2	SETTING UP PROCEDURES	20
4.3	GROUND CONTROL OPERATION	21
4.4	PLATFORM CONTROL OPERATION.....	23
4.5	CAGE WEIGH SYSTEM.....	25
4.6	BATTERIES AND CHARGING.....	26
4.7	TRANSPORTING, TOWING, CRANEAGE, STORAGE AND SETTING TO WORK .	28
4.8	TRACTION DRIVE POSITIONING SYSTEM.....	32
5	Emergency Controls	34
5.1	GENERAL	34
5.2	IN THE EVENT OF AN INCAPACITATED OPERATOR.....	34
5.3	IN THE EVENT OF MACHINE FAILURE	34
5.4	INCIDENT NOTIFICATION	34
6	Responsibilities	34
6.1	CHANGES IN OWNERSHIP	34
6.2	MANUAL OF RESPONSIBILITIES	34
6.3	INSPECTION/SERVICE/PRE-HIRE CHECK LIST	35

1 Introduction and General Information

1.1 FOREWORD

The purpose of these manuals is to provide the customer with appropriate safety operating and maintenance instructions essential for proper machine operation.

All information in these manuals should be **READ** and fully **UNDERSTOOD** before any attempt is made to operate the machine. **THESE MANUALS ARE VERY IMPORTANT TOOLS** - Keep them with the machine at all times.

The manufacturer has no direct control over machine application and use, therefore conformance with good safety practices is the responsibility of the user and his operating personnel.

All information in these manuals is based on the use of the machine under proper operating conditions. Alteration and/or modification of the machine are strictly forbidden.

One of the most important facts to remember is that any equipment is only as safe as those who operate it.

DANGER, WARNING, CAUTION, IMPORTANT, INSTRUCTIONS AND NOTICE

Any place these topics may appear, either in this manual or on the machine, are defined as follows:

DANGER: If not correctly followed there is a high probability of serious injury or death to personnel.

WARNING OR CAUTION: If not correctly followed there is some possibility of serious injury or death to personnel.



THE 'SAFETY ALERT' SYMBOL IS USED TO CALL ATTENTION TO POTENTIAL HAZARDS THAT MAY LEAD TO SERIOUS INJURY OR DEATH, IF IGNORED.

IMPORTANT AND INSTRUCTIONS: Denotes procedures essential to safe operation and prevention of damage to or destruction of the machine.

NOTICE: Indicates general safety rules and/or procedures relating to the machine.

It is the owner's/user's responsibility to know and comply with all applicable rules, regulations, laws, codes and any other requirements applicable to the safe use of this equipment.

1.2 SCOPE

These operating instructions contain all the necessary information required to allow the safe operation of any Niftylift 150T (TM42T), powered by bi-energy (electric (DC) & petrol/gasoline (P) engine.

For further technical information, circuit diagrams and specific instructions for all maintenance which may need to be carried out by specialist trained personnel, see the associated Workshop and Parts manual for your model of Niftylift 150T (TM42T).

1.3 INTRODUCING THE 150T TRAILER MOUNT (TM) SERIES

Please note at the time of going to press all information, illustrations, details and descriptions contained herein are valid. Niftylift reserves the right to change, alter, modify or improve its products without any obligations to install them on previously manufactured machines.

If After reading this manual you require further information please do not hesitate to contact us at your nearest office.

Niftylift Ltd, Fingle Drive, Stonebridge, Milton Keynes MK13 0ER, Great Britain

Tel: +44 (0) 1908 223456 Fax: +44 (0) 1908 312733

Niftylift Inc, 32 Concourse Way, Greer, SC 29651 USA

Tel: +01 864 968 8881 Fax: +01 864 968 8836

Nifty Pty Ltd, 265 King Street, Newcastle, NSW 2300, Australia

Tel: +61 (0) 2 4929 6700 Fax: +61 (0) 2 4925 2570

The Niftylift 150T trailer mount is an extremely versatile articulated boom platform of unique and simple design. It is capable of placing two men and their tools up to a height of 14.65m (48ft) or an outreach of 7.53m (24ft 8in).

The booms are mounted via a 400° powered swing mechanism onto a compact base mounted on a single axle. The fully articulating booms give an outstanding working envelope. The large pneumatic wheels and minimal weight make the unit light and simple to manoeuvre.

A simple, all-hydraulic proportional control system gives smooth, reliable movement of the platform and maximum reliability in the harshest environments.

The Niftylift 150T is available with hydraulically powered outriggers, making setting up both swift and simple. A unique pressure sensitive microswitch system fitted to each outrigger prevents operation of the booms until all outriggers have been correctly deployed. This Operating Manual provides instructions for the hydraulic outriggers.

Models include the following:

E: - DC ELECTRIC

AC: - AC ELECTRIC

P: - PETROL

PE: - PETROL & BATTERY

1.4 GENERAL SPECIFICATION

FEATURE	150T
MAXIMUM HEIGHT - WORKING	14.65m 48ft
MAXIMUM HEIGHT - PLATFORM	12.65m 42ft
MAXIMUM HEIGHT - STOWED	2.0m 6ft 7in
MAXIMUM OUTREACH	7.5m 24ft 7in
MAXIMUM WIDTH - TOWING	1.6m 5ft 3in
JACK SPREAD (FULL PENETRATION)	3.90m Long x 3.84m Wide 12ft 10in Long x 12ft 7in Wide
MAXIMUM LENGTH - STOWED	5.55m 18ft 3in
MAXIMUM CAPACITY - (EUROPEAN) (USA)	225kg (496lb) 500lb
TURRET ROTATION	400°
PLATFORM SIZE - LENGTH X WIDTH	0.7m x 1.4m 27.5in x 55in
CONTROLS	Full proportional hydraulic
HYDRAULIC PRESSURE	210 Bar
TYRES	Bi-Energy 185 R14C 8PR 4.5 bar (65 psi)
GROUND CLEARANCE	215mm 8.5in
GROSS VEHICLE WEIGHT (MAXIMUM)	1725kg – 1800kg (Dependent upon options) 3757lb – 3978lb
MAXIMUM GROUND PRESSURE	0.038kn/cm ² 45PSI
POWER SOURCE	E (Electric) - 4 x 6v 245 AH Batteries P(G) (Petrol/Gasoline) - Honda GX160 Engine

1.5 IDENTIFICATION (UK PLATE)

			
NIFTYLIFT LTD. FINGLE DRIVE, STONEBRIDGE MILTON KEYNES MK13 0ER ENGLAND TEL 01908 223456 : FAX 01908 312733 e-mail : info@niftylift.com			
SERIAL No			
TYPE			
YEAR OF MANUFACTURE			
WEIGHT			kg
RATED LOAD	PERSONS	+	kg
MAXIMUM SAFE WORKING LOAD			kg
MAXIMUM PULL			N
MAXIMUM WIND SPEED			m/s
MAX. ALLOWABLE INCLINATION			Deg.
MAXIMUM HYDRAULIC PRESSURE			bar
MAXIMUM VOLTAGE			V
AMPS			A
ELEC. CCT D	ISSUE		
HYD. CCT D	ISSUE		
			P10805

This manufacturer's plate is attached to the Base on each machine at the time of manufacture on every Niftylift. Please ensure all sections have been stamped and are legible.

1.5a IDENTIFICATION (USA PLATE)

	
NIFTYLIFT LTD. FINGLE DRIVE, STONEBRIDGE MILTON KEYNES MK13 0ER GREAT BRITAIN TEL (01144)1908 223456 : FAX (01144) 1908 312733 e-mail : info@niftylift.com	
THIS WORK PLATFORM COMPLIES WITH ANSI STANDARD A 92-	
MODEL	
SERIAL NO	
YEAR OF MANUFACTURE	
CAPACITY RATING	LBS
PLATFORM HEIGHT	FEET
GROSS WEIGHT	LBS
MAXIMUM HYDRAULIC PRESSURE	PSI
MAXIMUM VOLTAGE	V
AMPS	A
ELEC. CCT D	ISSUE
HYD. CCT D	ISSUE
P11497	

This manufacturer's plate is attached to the Base on each machine at the time of manufacture on every Niftylift. Please ensure all sections have been stamped and are legible.

2 Safety

2.1 MANDATORY PRECAUTIONS

When operating your Niftylift, your safety is of utmost concern. In order to fully appreciate all aspects of the machine's operation it should be ensured that each operator has **READ** and fully **UNDERSTOOD** the relevant manual covering machine use, maintenance and servicing. If any doubts exist concerning any points covered in your manual, contact your local dealer or Niftylift Ltd.

Before using any Niftylift, thoroughly inspect the machine for damage or deformation to all major components. Likewise, check the control systems for hydraulic leaks, damaged hoses, cable faults or loose covers to electrical components. At no time should damaged or faulty equipment be used - Correct all defects before putting the platform to work. If in doubt, contact your local dealer or Niftylift Ltd (see front cover for address).



THE MANUFACTURER HAS NO DIRECT CONTROL OVER THE MACHINE APPLICATION AND USE. THEREFORE CONFORMANCE WITH GOOD SAFETY PRACTICES IS THE RESPONSIBILITY OF THE USER AND HIS OPERATING PERSONNEL. FAILURE TO UNDERSTAND AND FOLLOW ALL SAFETY RULES COULD RESULT IN SERIOUS INJURY OR DEATH.

- 2.1.1** Only trained persons will be permitted to operate the Niftylift.
- 2.1.2** Always operate the Niftylift in full accordance with the manufacturer's Operating & Safety Instructions for that model.
- 2.1.3** Before use each day and at the beginning of each shift the Niftylift shall be given a visual inspection and functional test including, but not limited to, operating and emergency controls, safety devices, personal protective clothing, including fall protection, air, hydraulic and fuel system leaks, cables and wiring harness, loose or missing parts, tyres and wheels, placards, warnings, control markings and Operating and Safety Manuals, guards and guard rail systems and all other items specified by the manufacturer.
- 2.1.4** Any problems or malfunctions that affect the safety of operations shall be repaired prior to the use of the Niftylift.
- 2.1.5** Always ensure that all warning labels, instructions, placards, control markings and Safety Manuals are intact and clearly legible. If replacements are required contact your local dealer or Niftylift. Always observe and obey safety and operating instructions on such labels.
- 2.1.6** Do not alter, modify or disable in any way the controls, safety devices, interlocks or any other part of the machine.
- 2.1.7** Before the Niftylift is used and during use the user shall check the area in which it is to be used for possible hazards such as, but not limited to, uneven ground drop-offs, holes, bumps, obstructions, debris, floor and overhead obstructions, high voltage conductors, wind and weather, unauthorised persons and any other possibly hazardous conditions.
- 2.1.8** Never exceed the maximum platform capacity, as indicated on the decals and machine serial plate.

Operating & Safety Instructions

- 2.1.9** Never position any part of the Niftylift within 4.0m, (12ft) of any electrical power line, conductor or similar not exceeding 66kV. (Minimum span 125m) Other distances for increased voltages and different spans are given in NZECP 34:1993.



THIS MACHINE IS NOT INSULATED.

If in doubt, contact the appropriate authorities.

- 2.1.10** On entering the platform ensure that the sliding midrail is fully down in its correct “closed” position.

- 2.1.11** Use of an approved safety belt and lanyard, hardhat and appropriate safety clothing is strongly recommended for operator safety. Fasten harness to designated harness securing points within the platform and do not remove until leaving the platform with the cage within 400mm of the ground.



Always remain standing within the platform. Do not attempt to increase your height or reach by standing and/or climbing on the platform guardrails or any other object. **KEEP YOUR FEET ON THE PLATFORM FLOOR.** Do not sit, stand or climb on the guardrail, mid rail or boom linkage. Use of planks, ladders or any other devices on the Niftylift for achieving additional height or reach is prohibited.

- 2.1.12** To obtain the correct platform position above the ground when initially setting up the machine, use the base functions for booms and telescope to position the platform for safe entry to the platform.



THE PLATFORM FLOOR MUST BE WITHIN 400MM OF THE GROUND WHEN ENTERING OR EXITING. DO NOT CLIMB IN OR OUT OF THE PLATFORM WITH THE BOOMS IN THE TRANSPORT POSITION.

- 2.1.13** Do not use the platform to lift overhanging or bulky items that may exceed the maximum capacity or carry objects that may increase the wind loading on the platform. (e.g. Notice boards etc.)

- 2.1.14** The Niftylift shall not be operated from a position on trucks, trailers, railway cars, floating vessels, scaffolds or similar equipment unless Niftylift Ltd in Great Britain approves the application in writing.

- 2.1.15** Always check below and around the platform before lowering or slewing to ensure that the area is clear of personnel and obstructions. Care should be taken when slewing out into areas where there may be passing traffic. Use barriers to control traffic flow or prevent access to the machine.

- 2.1.16** Stunt driving or horseplay, on or around the Niftylift, shall not be permitted.

- 2.1.17** When other moving equipment and vehicles are present, special precautions shall be taken to comply with local ordinances or safety standards established for the work place. Warnings such as, but not limited to, flags, roped off areas, flashing lights and barricades shall be used.

- 2.1.18** It shall be the responsibility of the user to determine the hazard classification of any particular atmosphere or location. Aerial platforms operated in hazardous locations shall be approved and of the type required. (For the USA refer to ANSI/NFPA 505-1987.)

- 2.1.19** The operator shall immediately report to his supervisor any potentially hazardous location(s) (environment) which become evident during operation.

- 2.1.20** If an operator encounters any suspected malfunction of the Niftylift or any hazard or potentially unsafe condition relating to capacity, intended use or safe operation he shall cease operation of the Niftylift and request further information as to safe operation from his management, or owner, dealer or manufacturer before further operation of the Niftylift.
- 2.1.21** The operator shall immediately report to his superior any problems or malfunctions of the Niftylift, which becomes evident during operation. Any problems or malfunctions that affect the safety of operation shall be repaired prior to continued use.
- 2.1.22** The boom and platform of the Niftylift shall not be used to jack the wheels off the ground.
- 2.1.23** The Niftylift shall not be used as a crane.
- 2.1.24** The Niftylift shall not be positioned against another object to steady the platform.
- 2.1.25** Care should be taken to prevent rope, electric cords and hoses from becoming entangled in the aerial platform.
- 2.1.26** Batteries shall be recharged in a well-ventilated area free of flame, sparks or other hazards that may cause explosion. Highly explosive hydrogen gas is produced during the charging process.
- 2.1.27** When checking electrolyte levels great care should be taken to protect eyes, skin and clothing. Battery acid is highly corrosive and protective glasses and clothing is recommended.
- 2.1.28** When the machine is not in use always stow the booms correctly. **NEVER LEAVE THE KEYS IN THE MACHINE**, if it is to be left for any period of time. Use wheel chocks if leaving on an incline.
- 2.1.29** If the platform or elevating assembly becomes caught, snagged or otherwise prevented from normal motion by adjacent structure or other obstacles, such that control reversal does not free the platform, all personnel shall be removed from the platform safely before attempts are made to free the platform using ground controls.
- 2.1.30** The engine must be shut down while fuel tanks are being filled. Fuelling must be done in a well-ventilated area free of flame, sparks or any other hazard that may cause fire or explosion. **PETROL (GASOLINE), LIQUID PROPANE AND DIESEL FUELS ARE FLAMMABLE.**



NEVER START THE NIFTYLIFT IF YOU SMELL PETROL (GASOLINE), LIQUID PROPANE OR DIESEL FUEL. THESE FUELS ARE HIGHLY FLAMMABLE.

- 2.1.31** The operator shall implement means provided to protect against use by unauthorised persons.
- 2.1.32** Never remove anything that may affect the stability of the machine such as, but not limited to, batteries, covers, engines, tyres or ballast.
- 2.1.33** Ensure that the machine is stowed in the transport position before towing: Booms central with centring post engaged, telescope fully retracted booms down, and outriggers fully stowed (Cylinders closed).

Operating & Safety Instructions



IF THE MACHINE IS TOWED OUT OF THE TRANSPORT POSITION, THEN THE ROAD LIGHTS MAY BE OBSCURED AND THE BALANCE OF THE MACHINE DURING TRANSPORT WILL BE INCORRECT.

2.2 ENVIRONMENTAL LIMITATIONS

All Niftylift Trailer Mounts are limited to operation as previously described and any slopes must be adjusted by using the outriggers. Unless specifically configured otherwise, the machine will have short time rating for operation in extreme temperatures, i.e. reduced battery cycle times for low temperatures such as freezers, food storage etc. and cooling limitations for high temperatures as oil temperature must remain between -23° and 93° Celsius.

Extended operation in dusty environments is not recommended and frequent cleaning will be necessary. All dust, dirt, salt encrustation, excess oil or grease should be removed. Deposits of paint or bitumen, particularly on legends or labels should also be removed.

All standard Niftylift machines are rated for a wind speed of 12.5 m/s, which equates to 45kph / 28mph or force 6 on the Beaufort scale. No attempt should be made to operate a Niftylift in wind strengths above this limit and if the operator has any doubts over the wind speed he / she should cease operation immediately until it can be established that the wind speed has fallen to a safe level.



DO NOT USE THE NIFTYLIFT IN ELECTRICAL STORMS.

2.3 NOISE AND VIBRATION

The airborne noise emission on the 150T range of machines does not exceed 73dB(A), measured at a perpendicular distance of 4m, under equivalent continuous A-weighted sound pressure test conditions. This was based on a Diesel powered machine, working under load. All other models will exhibit significantly lower emissions than this figure, dependant on power option.

In normal operation the Vibration level to which the operator is subjected will not exceed a weighted root mean square acceleration value of 2.5 m/s².

3 Preparation and Inspection

3.1 UNPACKING

Since the manufacturer has no direct control over the shipping or carriage of any Niftylift it is the responsibility of the dealer and/or owner and/or leaser to ensure the Niftylift has not been damaged in transit and a Pre-operational Report has been carried out by a qualified engineer before the aerial platform is put into service.

- 1) Remove all ropes, straps and or chains used to secure the aerial platform during transit.
- 2) Ensure any ramp, loading dock or forklift used is capable of supporting or lifting the aerial platform.

*****Carry out the Pre-operational Report before placing machine in service.**

3.2 PREPARATION FOR USE



Whilst every effort has been made at the Niftylift factory to ensure your machine arrives in a safe and operable condition it is necessary to carry out a systematic inspection prior to putting the aerial platform into service.
THIS IS NOT A REQUEST IT IS MANDATORY.

To assist the user in this task you will find enclosed an Inspection Check List (see section 6.3), which must be filled out upon delivery/receipt of the machine.

Before the user carries out the Inspection Check List he must have read and fully understood all the contents of the Operating, Safety and Maintenance Manual.



WARNING - DO NOT OPERATE A POTENTIALLY DEFECTIVE OR MALFUNCTIONING MACHINE. CORRECT AND REPAIR ANY DEFECTS BEFORE OPERATING YOUR NIFTYLIFT.

3.3 PRE-OPERATIONAL SAFETY CHECK SCHEDULES

Before use at the beginning of the work shift, the aerial platform shall be given a visual inspection and functional tests including, but not limited to the following. It is recommended that these be performed at regular intervals as indicated on each checklist.

3.3.1 DAILY SAFETY CHECKS

- 1) Check that all labels (decals) are in place and legible.
- 2) Visually inspect the machine for damaged or loose components.
- 3) Check that batteries are charged (if applicable) i.e. Charger has a solid green light and a pulsing red light.
- 4) Check the fuel level (if applicable).
- 5) Check that canopies/covers and guards are in place and secure.
- 6) Check that the boom rest switch is operable.
- 7) Check that control levers are secure and operate freely.
- 8) Check that operating buttons and emergency stop buttons function properly.
- 9) Check the operation of the emergency hand pump.
- 10) Visually inspect all hydraulic hoses and fittings for damage or leaks.
- 11) Check operation of the outrigger alarm.
- 12) Check that outrigger footpads are secure.
- 13) Check that the platform pivot pins and their swing bolts are secure.
- 14) Check the operation of the cage weigh system (If fitted). Refer to Section 4.5 for further information.

3.3.2 WEEKLY SAFETY CHECKS

- 1) Inspect tyres and wheels for damage and wear.
- 2) Check tyres for correct pressure. 65psi (4.5 bar)
- 3) Check mudguards for security and damage.
- 4) Check battery fluid levels and specific gravity (after charging) and general condition.
- 5) Check hydraulic oil level (ISO Grade 32).
- 6) Inspect the engine air filter and clean or replace if necessary.
- 7) Check that the tow hitch ball lock, breakaway cable/chain and jockey wheel are secure.
- 8) Check operation and security of outrigger micro switches in conjunction with the alarm system.
- 9) Inspect hose track for damage or missing parts.

3.3.3 MONTHLY SAFETY CHECKS

- 1) Check the engine oil level (if applicable).
- 2) Check the wheel nuts (torque 80ft lbs / 110Nm).
- 3) Check outriggers for condition, security and operation.
- 4) Check that the slew worm is secure and correctly in mesh. Clean and re-grease.
- 5) Inspect brakes for operation and wear.
- 6) Inspect the engine fuel tank for damage or leaks.
- 7) Check telescopic boom wear pads and nylon studs (if applicable).
- 8) Grease the tow hitch assembly.
- 9) Check and adjust if necessary the Nylatron studs around the telescope boom.
- 10) Every **Six** months perform a **thorough examination** in accordance with the 'Lifting Operation and Lifting Equipment Regulations' (LOLER) 1998, Regulation (9)(3)(a).

3.3.4 ANNUAL SAFETY CHECKS

- 1) Check that all pivot pins and their swing bolts are secure.
- 2) Inspect for any cracks or badly rusted areas on booms and chassis.
- 3) Change the hydraulic oil and the oil filters.
- 4) Inspect the suspension on each axle unit.
- 5) Check that slew ringbolts are secured (torque 206ft lbs. / 279Nm).

Operating & Safety Instructions**3.4 PLACARD, DECALS & INSTALLATION (UK)**

ITEM	DESCRIPTION	NUMBER	QTY
1	Daily Safety Checks	P14908	1
2	If Tilt Alarm Sounds	P18842	2
3	General Crash	P14782	6
4	Cage Gate Warning	P18335	1
6	Coupling Instructions	P14896	1
7	Harness Points	P14883	2
8	Component Stability	P19708	1
9	Tyre Pressure 65psi	P14876	2
10	No Step	P14785	8
11	Emergency Handpump	P17854	1
12	Wheel Nut Torque, 110nm	P18772	2
13	General Warning	P18672	2
14	Head Protection	P14921	1
15	Serial Plate	P15383	1
16	General Notice	P18863	1
17	Swl 225 Kg	P17328	1
18	Nifty 150T - Grey	P17787	2
19	Niftylift.Com	P14390	1
21	Hydraulic Controls – 5 Levers	P18259	1
22	Point Load – 12.2 kN	P18625	4
23	Outriggers Warning	P14841	4
24	Outriggers Control	P14922	1
25	Hydraulic Controls – 4 Levers	P14928	1
26	Lid, Cage Console	P17522	1
27	Base Controls	P17219	1
28	Hazard Tape		A/R
29	Battery - Isolator	P18600	1
31	Battery - Charger	P14904	1
33	Petrol Off	P19055	1
34	Noise Warning 73db	P17123	1
37	Read Manual	P14892	1
39	Overload Warning	P18848	2
40	E-Stop Warning	P14864	2
41	Cage Entry 400 mm	P18192	2
42	Booms Stowed Warning	P18198	2
43	Oil Fill Warning	P18206	1
44	Oil Fill Level	P18252	1
45	50mm Tow Hitch (Australia Only)	P17970	1
46	11m Key Switch (Australia Only)	P18433	1
48	Footswitch	P14884	1
49	Hand Crush (Traction Drive)	P14782	2
50	Traction Drive – Engage	P18890	1
51	Traction drive – On slope	P18976	1
52	Traction Drive - Release	P18975	1

nifty™ Series

Operating & Safety Instructions

54	11m Height Restriction (Australia/NZ only)	P19046	1
57	Battery Charger Socket	P19699	1
58	230v Socket	P17720	1

nifty

150T Series

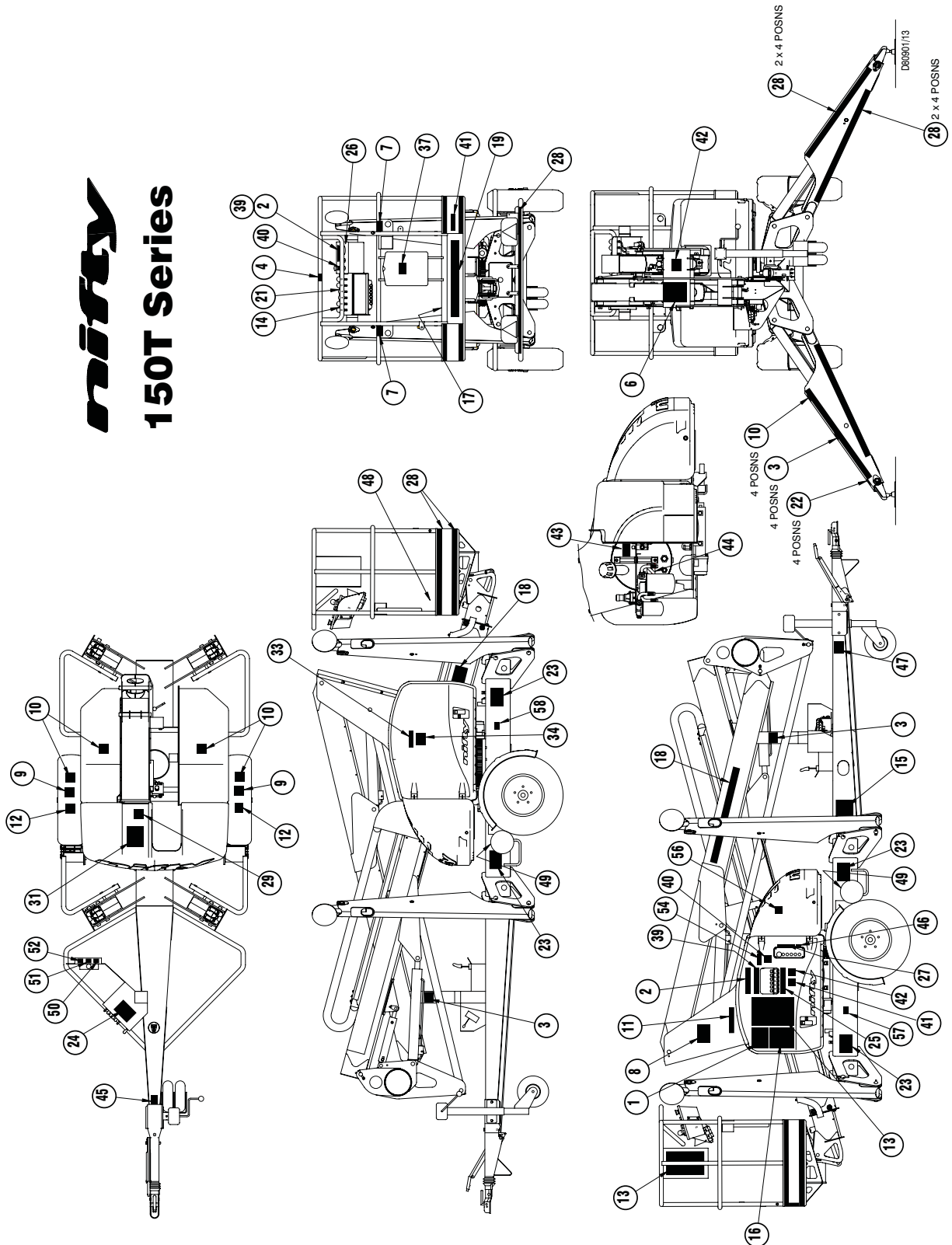

nifty TM Series

Operating & Safety Instructions

3.4a PLACARD, DECALS & INSTALLATION (USA)

ITEM	DESCRIPTION	NUMBER	QTY
1	Daily Safety Checks	P14908	1
2	If Tilt Alarm Sounds	P18842	2
3	General Crash	P14782	6
4	Cage Gate Warning	P18335	1
5	Rotating Machinery	P15010	2
6	Coupling Instructions	P14896	1
7	Harness Points	P14883	2
8	Component Stability	P19708	1
9	Tyre Pressure 65psi	P14876	2
10	No Step	P14785	14
11	Emergency Handpump	P17854	1
12	Wheel Nut Torque, 110nm	P18772	2
13	General Warning	P18672	2
14	Head Protection	P14921	1
15	Serial Plate	P15383	1
16	General Notice	P18863	1
17	Swl 225 Kg	P17328	1
18	Nifty TM42T - Grey	P19595	2
19	Niftylift.Com	P14390	1
21	Hydraulic Controls – 5 Levers	P18259	1
22	Point Load – 12.2 kN	P18625	4
23	Outriggers Warning	P14841	4
24	Outriggers Control	P14922	1
25	Hydraulic Controls – 4 Levers	P14928	1
26	Lid, Cage Console	P17522	1
27	Base Controls	P17219	1
28	Hazard Tape		A/R
29	Battery - Isolator	P18600	1
31	Battery - Charger	P14904	1
33	Petrol Off	P19055	1
34	Noise Warning 73db	P17123	1
37	Read Manual	P14892	1
39	Overload Warning	P18848	2
40	E-Stop Warning	P14864	2
41	Cage Entry 16 “	P19603	2
42	Booms Stowed Warning	P18198	2
43	Oil Fill Warning	P18206	1
44	Oil Fill Level	P18252	1
48	Footswitch	P14884	1
49	Hand Crush (Traction Drive)	P14782	2
50	Traction Drive – Engage	P18890	1
51	Traction drive – On slope	P18976	1
52	Traction Drive - Release	P18975	1
56	Warning – Battery Drain	P18891	1
57	Engine emissions	P15334	1

58	230v Socket	P17720	1
59	Battery Charger Socket	P19699	1

nifty
TM42T Series

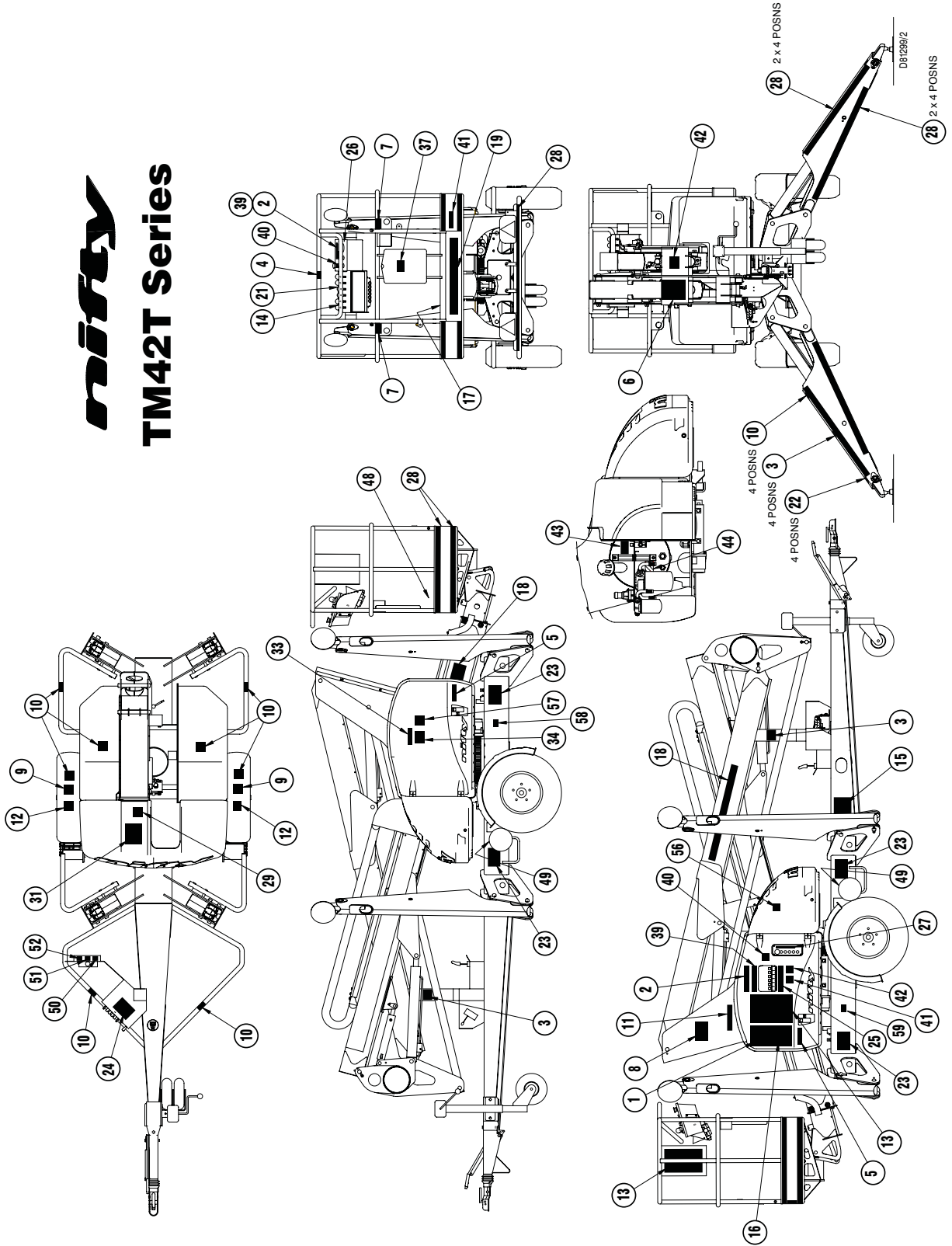

3.5 TORQUE REQUIREMENTS

SCREW QUALITY/SIZE	Tightening torque in ft lbs (Nm)			
Grade		8.8		10.9
M 6	7.4	(10)	10	(14)
M 8	18.5	(25)	26	(35)
M 10	36	(49)	51	(69)
M 12	65	(86)	89	(120)
M 14	100	(135)	140	(190)
M 16	155	(210)	218	(295)
M 18	215	(290)	300	(405)
LOAD CELL BOLTS	147ft lbs		200Nm	
WHEEL NUTS	80ft lbs		110Nm	
SLEW RING BOLTS	206ft lbs		279Nm	

4 Operation

4.1 CONTROL CIRCUIT COMPONENTS

4.1.1 CONTROL BOARD: - Situated under the control canopy, the control board comprises a PCB (printed circuit board) design that incorporates all of the relays to control the machine operation. The control board is common between models with the same power source, and will contain, where appropriate, discrete fuses for the circuits concerned.

4.1.2 KLAXON: - Also mounted under the control canopy is a klaxon, which is interlocked into the outrigger control circuit. It is this device that sounds continuously if a jack goes light in operation, with the booms raised, warning the operator of this condition. It will also sound if the Ground Control Key switch is turned to Platform position before the outriggers are deployed.

4.1.3 SWITCHES: - There are two switches:

Boom-Switch - Mounted on the side of the superstructure near the boom rest and operated by contact with the section 1,

Slew Centring Switch - Mounted on the under side of the superstructure and operated by dropping into a gap in the slew spacer plate on the base.

These switches control the changeover function between outriggers and platform. The outrigger control function is not available unless all of these switches are engaged, ensuring that the machine must be stowed to operate the hydraulic outriggers. It is also similarly linked into the platform control circuit, such that if the switches are not engaged, (i.e. machine is in operation) then the outrigger sensors are active and would warn the operator of an unsafe condition, should one of them loose contact with the ground. These control functions are of primary importance to safety of the machine and operator, under no circumstances should they be isolated or by-passed.

4.1.4 BATTERY ISOLATOR: - A red battery isolator handle is located beneath the battery canopy which allows the machine control and power circuits to be isolated from the batteries themselves. Under normal operation, the machine Key switch should be used to isolate the machine with the Battery Isolator only being required to disconnect the batteries for maintenance or in the event of a short circuit. The battery charging circuit is connected directly to the battery side, so charging is un-affected by use of this switch.

4.1.5 POWER SOURCE SELECTION: - On multiple power option machines, the machine is fitted with an 'instinctive' circuit for power source selection. Pressing the green button will automatically select battery operation. The engine can be started using the two position START/STOP selector in the platform and the machine will 'default' to engine operation via a flow switch in the hydraulic circuit. Stopping the engine by selecting STOP on the two-position selector in the platform and pressing the green button will return the machine to battery mode. The engine is started from the base by turning the switch on the engine, under the engine canopy.

4.1.6 PETROL ENGINE: - Generally a Honda GX 160 engine, described in the maintenance section of the Workshop Manual, driving a single body pump with direct mounted pump dump valve.

Operating & Safety Instructions

4.2 SETTING UP PROCEDURES



FAILURE TO DEPLOY THE OUTRIGGERS CORRECTLY COULD RESULT IN DEATH OR SERIOUS INJURY.

ALL MODELS

- 1) Read and fully comply with all safety precautions and operating instructions in the Operating and Safety manual and the warning decals on the machine.
- 2) Position Niftylift on firm ground, bearing in mind range of boom movement so that any overhead obstructions or possible hazards such as, but not limited to, power cables, telephone lines, drains, manhole covers, etc. can be safely avoided
- 3) **APPLY HANDBRAKE:** Chock wheels and cordon off the area using appropriate cones, barriers and flags.
- 4) Levelling the machine using the hydraulic outriggers can accommodate a slope of up to 12 degrees, if necessary using suitable load bearing pads to support the downhill outriggers. Do not elevate the platform unless the base can be corrected to within one degree of level.
- 5) If the load bearing capacity of the ground is in any doubt the machine must NOT be used.
- 6) Check all red emergency stops are not engaged (i.e. fully out by twisting them in the direction of the arrows).
- 7) Ensure that the key switch at the ground control station is turned to the "ON" position (i.e. clockwise).
- 8) At the outrigger control station press down and hold the power lever on the right hand side. This activates the power and diverts hydraulic flow to the legs for setting up. Then select the appropriate control lever to begin setup. Note: No power will be available if the booms are not stowed onto the boom rest.
- 9) Using the four outrigger control levers, lower each outrigger onto a firm, level surface and level the machine base ensuring each outrigger foot is taking equal weight with the wheels clear of the ground. Note: Deploy the front two outriggers first to minimise the risk of damaging the jockey wheel.
- 10) Check that the base is level using the spirit level adjacent to outrigger control station as a guide.
- 11) The booms can now be operated from the ground control station by pressing and holding the green power button. Note: If the klaxon alarm sounds check that each outrigger is lowered and each footpad is loaded.
- 12) Always lower booms fully before adjusting, raising, retracting or moving the outriggers in any way.
- 13) Never alter, modify or block any of the safety circuits on the Niftylift.



THIS MACHINE IS NOT ELECTRICALLY INSULATED. DO NOT WORK WITHIN 10FT (3M) OF OVERHEAD CABLES EXCEEDING 415 VOLTS

4.3 GROUND CONTROL OPERATION



ALWAYS ALLOW THE ENGINE TO WARM UP BEFORE OPERATION.

4.3.1 GROUND CONTROL INSTRUCTIONS

ALL MODELS

- 1) Check below, above and around the platform for any obstructions or hazards before operating any function.
- 2) Ensure all red emergency stops are out.
- 3) Turn the key switch at the ground control station to the “ON” position (i.e. clockwise).
- 4) Battery/Electric models go to step 11).

PETROL ENGINE OR BI-ENERGY MODELS

- 5) Turn the main engine ignition switch, located on the side of the canopy through “ON” to the “ST” (start) position and the engine will fire.
- 6) Go to step 11). Note – Unless the petrol engine is running, the 150T will automatically default to the primary power source (usually battery)

PETROL (GASOLINE) ENGINE OR PETROL (GASOLINE)/ELECTRIC MODELS

- 7) For a cold engine start go to step 8) or for a warm engine start go to step 9).
- 8) **COLD ENGINE:** - turn the engine fuel tap “ON” and engage the choke lever. Turn the main engine ignition through “ON” to “ST” (Start) and the engine will fire. Return the choke lever to its normal running position after the engine is started.
- 9) **WARM ENGINE:** - turn the engine fuel tap on and turn the main engine ignition through “ON” to “ST” (start) position and the engine will fire.
- 10) Go to step 11). Note – Unless the petrol engine is running, the 150T will automatically default to the primary power source (usually battery)

ALL MODELS

- 11) Push and hold green power button.
- 12) Select the boom function required and operate hand levers in full accordance with manufacturer’s Operating and Safety manual.
- 13) When not in use return machine to stowed position, fully raise and stow all outriggers, turn the key to the “OFF” position (i.e. anti-clockwise), remove key and chock wheels.

EMERGENCY PROCEDURES

- 1) Push in red emergency stop to shut down all functions.
- 2) Use emergency hand pump (located under control canopy) to provide motive power and manoeuvre the machine as normal using the hand levers (Platform or Base).

Operating & Safety Instructions

BOOM FUNCTIONS

- 1) Push and hold green power button.

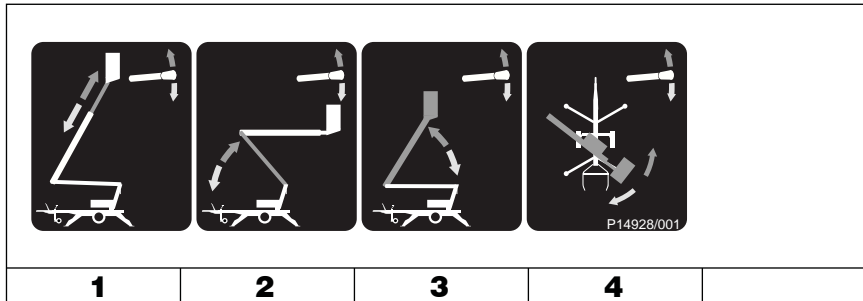

- 2) Select lever 1, 2, 3 or 4 for desired boom function.

1 Operates Telescope	UP for out	DOWN for in.
2 Operates Lower Boom	UP for up	DOWN for down
3 Operates Upper Boom	UP for up	DOWN for down
4 Operates Swing	UP for right	DOWN for left



ALWAYS ENSURE THE AERIAL PLATFORM IS ON A FIRM SURFACE AND THE AREA IS FREE OF ANY OVERHEAD OBSTRUCTIONS.

ENGAGING THE RED EMERGENCY STOP BUTTON WILL SHUT DOWN THE ENGINE AND THE ELECTRIC CIRCUIT PREVENTING OPERATION OF ANY FUNCTION.

4.4 PLATFORM CONTROL OPERATION



NEVER START THE NIFTYLIFT IF YOU SMELL PETROL (GASOLINE), LIQUID PROPANE OR DIESEL. THESE FUELS ARE FLAMMABLE.

BEFORE OPERATING THE NIFTYLIFT ENSURE THAT EACH OPERATOR HAS READ AND FULLY UNDERSTOOD THE OPERATING MANUAL. FAILURE TO DO SO MAY RESULT IN DEATH OR SERIOUS INJURY.

*****FOR COLD START PROCEDURES SEE SECTION 4.3.1*****

ALWAYS ALLOW THE ENGINE TO WARM UP BEFORE OPERATING.

4.4.1 PLATFORM CONTROL INSTRUCTIONS

ALL MODELS

- 1) **NEVER** exceed the maximum platform capacity.
- 2) Check below, above and around the platform for any obstruction or hazards before operating any function.
- 3) Ensure all red emergency stops are out.
- 4) Remove the key from the ground control station (turn key anti-clockwise) and put the key in the platform control station and switch to "ON" (clockwise).
- 5) Battery electric models go to step 11).

PETROL ENGINE OR PETROL/ELECTRIC MODELS ONLY

- 6) Ensure that the fuel tap is turned to the "ON" position and that the main engine ignition switch is "ON". Turn the "Engine Start" switch on the platform control box clockwise and the engine will fire.
- 7) Note – Unless the petrol engine is running, the 150T will automatically default to the primary power source (usually battery)
- 8) IF THE ENGINE IS TOO COLD TO START FROM THE PLATFORM, TRY STARTING FROM THE GROUND CONTROLS AS DESCRIBED IN STEP 8) OF GROUND CONTROL OPERATION (REFER TO SECTION 4.3.1).

ALL MODELS

- 9) Push and hold green power button.
- 10) Select the boom function required and operate hand levers in full accordance with manufacturers Operating and Safety manual.
- 11) When not in use return machine to stowed position, fully raise and stow all outriggers, turn the key to the "OFF" position (anti-clockwise), remove key and chock wheels.

EMERGENCY PROCEDURES

- 1) Push in red emergency stop to shut down all functions.
- 2) Use emergency hand pump (located under control canopy) to provide motive power and manoeuvre the machine as normal using the hand levers (Platform or Base).

PLATFORM CONTROL STATION

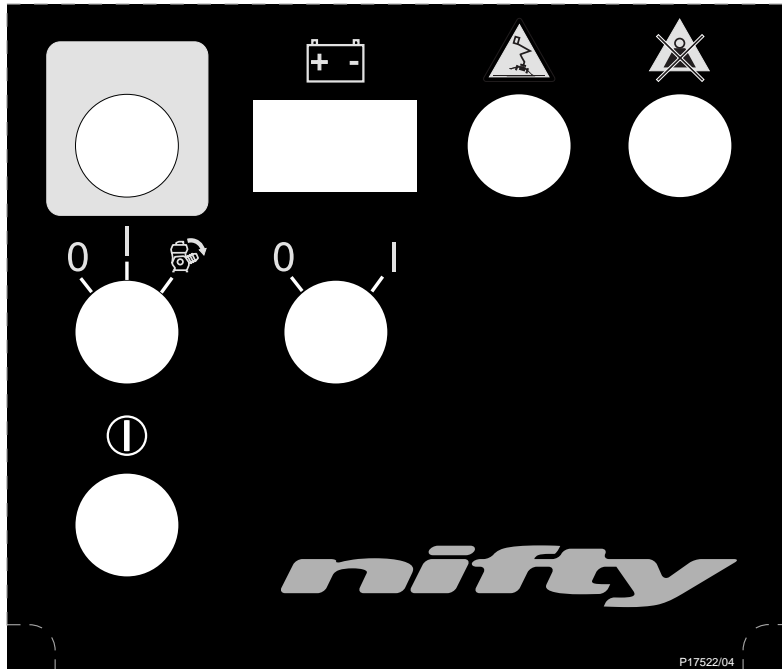

(BI-ENERGY MODEL)

BOOM FUNCTIONS

- 1) Push and hold green "Power Control" button.

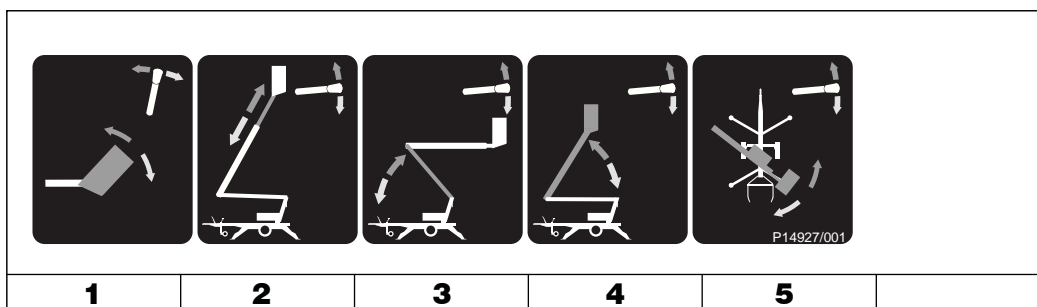

- 2) Select lever 1, 2, 3, 4 or 5 for desired function.

1 Operates Platform Levelling	FWD for forward	BACK for back
2 Operates Telescope	UP for out	DOWN for in.
3 Operates Lower Boom	UP for up	DOWN for down
4 Operates Upper Boom	UP for up	DOWN for down
5 Operates Swing	UP for right	DOWN for left

4.5 CAGE WEIGH SYSTEM

4.5.1 LOAD CELL VERSION

The Niftylift 150T is fitted with an electronic load cell. This load cell is a moment-independent, redundant design. This means that independent of the load position inside the cage of the machine, the actual load is measured and if pre-configured limit values are exceeded, warnings will be activated. “Redundant design” means that the load cell design incorporates dual channels that monitor each other. The design of the unit meets the requirements of both EN280 and EN954-1 class III.

4.5.2 CALIBRATION, INSPECTION AND MAINTENANCE

Calibration, maintenance and repair of the Niftylift 150T cage load cell requires specialist knowledge and equipment. For this reason, no part of the Niftylift 150T cage-weigh system can be adjusted, repaired or inspected by the operator. All enquiries relating to calibration, inspection or maintenance should be directed to Niftylift or one of their approved dealers. Contact details are listed in Section 1.3.

4.6 BATTERIES AND CHARGING



BATTERIES MUST BE RECHARGED IN A WELL-VENTILATED AREA FREE OF FLAME, SPARKS OR OTHER HAZARDS THAT MAY CAUSE EXPLOSION. HIGHLY EXPLOSIVE HYDROGEN GAS IS PRODUCED DURING THE CHARGING PROCESS.

- 1) Recharge batteries at the end of every working day or shift.
(**Note:** To recharge batteries fully from flat takes approx. 12 Hours, this consists of 8 hours bulk charging plus 4 hours equalisation).
- 2) Plug charger into suitable power supply, either 240 volts or 110 volts AC (see **Charging Limitations**). (Note: If using 240V, use of a suitably rated Earth Leakage Circuit Breaker (ELCB) or Residual Current Device (RCD) at the point of supply is highly recommended.)
- 3) Take note of the indicators provided:

Red Light - Batteries are charging.

Pulsing Green light - the charge is equalising.

Constant Green light and pulsing Red light - the batteries are fully charged.



UNDER NO CIRCUMSTANCES SHOULD BATTERIES BE LEFT ON CHARGE FOR PERIODS IN EXCESS OF 24 HOURS

- 4) **DISCONNECT FROM POWER SUPPLY ONCE BATTERIES ARE FULLY CHARGED.** The machine can now be left unattended, however, in the event of the machine being left unused for extensive periods then a **4 to 6 hour** 'top-up' charge every **4 weeks** is recommended. A 'top-up' charge the day before use ensures a full day of operation from the machine.



UNDER NO CIRCUMSTANCES SHOULD A MACHINE BE LEFT FULLY DISCHARGED AS SEVERE BATTERY DAMAGE CAN OCCUR IN A RELATIVELY SHORT TIME.

- 5) To avoid damage to charger disconnect from mains supply before using machine.

Note:

- 1) If the charger is reconnected to the power supply shortly after it has gone through its full charging cycle the Red LED may come on although the batteries may be fully charged. The charger would then go through its complete cycle again at an accelerated rate, depending on the time difference between connection, reconnection and level of battery charge.

- 2) Some Niftylifts are fitted with a Battery Management System, which permanently monitors the condition of the batteries. When the batteries become discharged to 80% of their capacity the management system will begin to "shut down" the hydraulic power packs. This causes the drive/boom operating system to alternately stop and start, signalling to the operator that re-charging is necessary. However, there is sufficient power remaining to enable the operator to drive slowly to the nearest charging point.

Should the operator ignore the onset of the battery discharge warning the "shut down" of the motors will continue, until the machine is rendered in-operative. **Immediate charging will then be required.**

CHARGING LIMITATIONS

Battery charging times will increase slightly if using an 110V supply as opposed to a 240V supply. This is due to the connection of the primary coils being in parallel, which in effect only allows the transformer to see 220V. Similarly, the capacity of the 110V supply will decide the input current available; hence a small hand-tool transformer will not operate the battery charger efficiently, therefore:
- charging times will increase further due to input limitations.

Attention should also be given to the use of extension cables as power leads. Excessive cable lengths from the supply point to the battery charger will result in significant voltage drop, leading to a reduction in the chargers efficiency. In addition, inadequate sized cable cores will have a limiting effect on its current carrying capacity, which will again lead to a reduction in the chargers efficiency. Both of these can result in over-heating of the cable with the attendant risk of fire, short circuits or damage to the components themselves.

The charger requires a minimum battery voltage of 4.5 volts per battery (overall for two batteries 9 volts, for 4 batteries 19 volts for 8 batteries 38 volts). If the voltage is below these values then the charger will not function (Charger will not detect batteries to begin charge.) If the batteries have fallen to such a poor state they will have to be removed from the machine and charged individually with an independent charger until the optimum voltage has been reached. This is best performed at very low currents to 'recover' the batteries if sulphation has already started i.e. a 'trickle' charger. This can take several hours, possibly days. Careful monitoring of the rise of battery voltage will indicate when recovery has been achieved.

TOPPING UP

During the course of normal operation, the batteries should be inspected at least once a fortnight to check the level of electrolyte. During the end of charge, gassing takes place, which will cause a slight reduction in the volume of acid in the battery. This can be topped up with de-ionised water as required. During this inspection, it is useful to note any imbalance in the fluid levels. One indication of a faulty cell would be an increase in the loss of battery acid, which would then require more frequent topping up on that cell, or cells. Faulty cells can liberate excess hydrogen, even during normal operation, with the resulting risk of explosion if ignited. **Any faulty batteries should be replaced as soon as possible with an equivalent sized and rated unit.**

Note: Protective safety glasses and gloves (Appropriate PPE) MUST be worn whilst performing these checks.

Operating & Safety Instructions

4.7 TRANSPORTING, TOWING, CRANEAGE, STORAGE AND SETTING TO WORK

4.7.1 TRANSPORTING

If a work platform is to be moved over a longer distance, whether the machine is trailer mounted, vehicle mounted, self propelled or tracked, the following procedure should be read before restraints are attached to the machine. Cross loading is most frequently the cause of problems, as the method of loading is no longer under the control of our own personnel. The recommendations made herein should be passed on to subsequent carriers, such that the entire journey is carried out without incident.

- Always ensure the truck or trailer you are loading or towing the Niftylift with can carry it legally.
- If loading by crane the use of shackles and an adequately rated spreader beam, with four leg slings around indicated slinging points on base, is **MANDATORY**.
- When loading or un-loading from the side of the vehicle, the use of the forklift pockets to retain one of the forks is recommended. (If fitted). Spread the forks to their widest capacity, with due regard to the components fitted to the machine. **Never forklift or crane an entire machine under the booms**, always lift beneath the spine or under the ends of the axle mountings in the case of a self-propelled unit. Ensure forklift is adequately rated for the load to be carried. If the machine is fitted with Traction Drive, this needs to be engaged (as described in steps 1 to 5 of Section 4.7.2) with the drive barrels positioned in contact with the tyres. Access to the fork pockets is now possible by using an appropriate forklift that will span the tyre and fit through the fork pocket. Note: A large forklift will not be suitable as the wider forks require the full width of the fork pocket. Be careful not to damage the brake cables that pass underneath the base of the machine.
- Once positioned on the transport carrier, ratchet straps should be used to secure the machine. Pass the strap over the bosses located in the bottom of all four outrigger housings on the base and secure to the transport carrier. The machine should be positioned to allow easy access around the machine in transit, and to ensure that 'creepage' during transport does not permit the machine to come into contact with other goods being shipped, or the container itself. Some movement of the machine structure might occur during transit, which could lead to fretting or other damage.
- If the machine is equipped with a transit device such as a boom clamp etc, this should be securely applied.
- Strap booms carefully to constrain them from sideways movement. When using straps or chains, adequate packing should be applied to stop any damage to the structure and paintwork. Due regard of the movement of the straps or chains must be taken into account.
- Where a machine has designated points for strapping, lifting or forking, these can be used for tie-down duty. When they are absent, the major structure of the platform can be used, giving due consideration to the design and function of the area chosen. Where possible, use the spine of the machine or axle mounts over which to apply the holding down forces. Using a single plate, such as an outrigger or stabiliser support plate might be unsuitable. If the component was clearly not designed to accommodate a side load, one should not be applied.
- Under no circumstances should straps or chains be applied over booms or through the cage support structure or the cage itself. The relative strength of the carrying structure is not conducive to the massive forces capable of being applied through ratchet chains or slings.

Severe damage to the steelwork can be caused, as well as deformation to sensitive mechanisms such as cage weigh assemblies, which would render them useless. Such catastrophic damage to say, an electronic load cell would require the component to be replaced before the machine would function.

4.7.2 TOWING



ENSURE THE BOOMS ARE FULLY STOWED BEFORE TRANSPORTING. THE MAXIMUM RECOMMENDED TOWING SPEED OF A 150T (TM42T) NIFTYLIFT IS 60 MPH (96 KPH) WITH A VEHICLE THAT COMPLIES WITH ALL ROAD TRAFFIC REGULATIONS. IT IS THE DRIVER'S RESPONSIBILITY TO OBEY ANY SPEED RESTRICTIONS THAT FURTHER REDUCE THE ALLOWABLE TOWING SPEED. SPEEDING MAY RESULT IN DEATH OR SERIOUS INJURY.

It is recommended that the maximum towing speed of 60mph (96kph) be adhered to for the greatest safety. The speed must be further reduced when local traffic restrictions require it. In other than perfect conditions it is sensible to further reduce your speed in order to ensure full control over your vehicle and trailer. The importance of the suitability of your towing vehicle must be stressed. The vehicle manufacturer's details concerning each model will give you recommended Gross Vehicle Weights (GVW) or Gross Train Weights (GTW) neither of which should be exceeded.

POSITION TOWING VEHICLE AND TRAILER ON LEVEL GROUND BEFORE ATTEMPTING TO COUPLE/DE-COUPLE.

Coupling Instructions

- 1) Depress the trigger on the lever mechanism and lift the handle upwards and forward.
- 2) Place the unlocked coupling head onto the towing ball and apply slight downward pressure. The head will automatically lock onto the ball.
- 3) Ensure that the trigger has returned to its free position before attempting to tow, and that the coupling head is securely on the towing ball.
- 4) Connect the breakaway cable/chain to the towing vehicle hitch - not to the tow ball itself.
- 5) Connect the lighting plug to the vehicle and check the light functions.
- 6) Raise the jockey wheel to its stowed position and secure for transit.

De-coupling Instructions

- 1) Apply trailer handbrake and chock wheels.
- 2) Lower the jockey wheel to the ground. Disconnect the breakaway cable/chain and lighting plug.
- 3) Operate the handle by depressing the trigger and manually lift the coupling head clear of the towing ball or screw down the telescopic jockey wheel to achieve the same effect.

Handbrake Operation

- 1) To operate the trailer parking brakes pull the handbrake lever upwards and backwards. The spring-loaded mechanism will engage and stay in the operated position until re-set.
- 2) To disengage the parking brakes, firmly grasp the handbrake lever and pull upwards. Depress the ratchet release button in the end of the handbrake lever and return the lever to the horizontal position. Care should be taken when operating the handbrake lever due to the forces involved in engaging the ratchet mechanism.

Operating & Safety Instructions

4.7.3 CRANEAGE

- 1) Observe all of the limitations relating to straps and chains stated above under 'Transporting'. (Section 4.7.1)
- 2) When utilising the designated lifting points never apply a 'snatch' load, i.e. lift slowly to take up the load before raising. Similarly, do not drop machine when positioning after lifting.
- 3) If the machine is to be lifted by crane, use the designated lifting points and observe the recommendations regarding spreader beams. Individual drawings are available for each machine type, on request. (See list below.)

D80904	90
D81193	120M
D80541	120T/H
D80905	140H
D81273	150T
D80906	170H
D80939	210TM

4.7.4 STORAGE

If being stored for any length of time without use, then the machine should be thoroughly inspected for the following: -

- 1) Grease all bearings /slides, worm drives, etc.
- 2) Check batteries for electrolyte levels, state of charge, damage, dirt, etc. Never leave in a state of discharge for any length of time. If no use of the platform is intended, an occasional "top-up" charge of the batteries will serve to equalise their charge level.
- 3) Leave battery disconnect switch in OFF position to prevent discharge of batteries through leakage.
- 4) If machine is to be left on an incline, chock wheels to prevent creep.
- 5) If machine is to be left outdoors or in a hostile environment, cover with suitable weatherproof media to prevent deterioration.

4.7.5 SETTING TO WORK

Before use each day and at the beginning of each shift the machine shall be given a visual and functional test including, but not limited to, the following

- 1) Check all lubrication points for adequate application of grease, oil etc.
- 2) Inspect all threads for ease of operation.
- 3) Check level and quantity of oil. Remove any contaminants - water, etc.
- 4) Check batteries for electrolyte and state of charge.
- 5) Check electrics for damage and insulation.
- 6) Using base controls, cycle machine over complete envelope in accordance with the Operating Instructions. Cure any defects.

- 7) Ensure that all safety devices and controls operate in accordance with the instructions.
- 8) If necessary, perform a load test to establish the machine stability before putting the machine to work.
- 9) On completion of an extended period of road transport, the machine might need additional inspection to identify any transit degradation, which could render the machine unsafe. Perform a P.D.I. inspection on the unit before it enters service. Record any faults found and rectify them immediately.
- 10) If left un-attended for an extended period, it is likely that the hydraulic cage levelling will become un-pressurised. Normal operation is then lost, with a noticeable delay in the forwards or backwards motion as the booms move. To restore normal function, the cage needs to be fully levelled forwards and backwards, using the cage-levelling lever whilst not standing in the cage (i.e. with the operator standing adjacent to the cage side whilst simultaneously operating the lever and green button to move the cage). Take care not to become trapped between the moving cage and a fixed object, and ensure those around you are clear of the moving cage. When the system has been charged in both directions, the cage levelling function should be restored. If the system operates but is 'jerky' in either direction, this indicates air in the system. Repeat the procedure as described above until the movements are smooth and un-interrupted. If in doubt, contact our Service Department for further advice.

Niftylift Limited is not liable for any third party damage caused during transport. Careful attention to correct procedures will prevent many of the small snags that can happen in transit. Re-work is both expensive and time consuming. A defective machine arriving at the place of work is a poor advertisement for our product, the company's reputation and those of our dealers and clients. The responsibility for safe and damage-free transport rests with the haulier or his representatives.

Operating & Safety Instructions

4.8 TRACTION DRIVE POSITIONING SYSTEM

4.8.1 DESCRIPTION

A Traction Drive Positioning System is an option for most trailer-mounted machines. The system is used for positioning the trailer in the work location and to assist coupling the trailer to the towing vehicle. The system is for use on flat level ground and must not be used to ascend or descend slopes in excess of 10% (5.7°) as this may result in serious injury. If the machine is to be moved up or down a slope in excess of 10%, a suitable towing vehicle must be used instead.

The Traction Drive Positioning System is driven hydraulically and powered by the machine's power system. The drive speeds and gradeability are therefore dependent upon the power available from the machine. The engagement of the Traction Drive Positioning System is also hydraulic and is controlled using a single hand lever to bring the drive barrels into contact with the road tyres. Manoeuvrability is controlled from a single joystick which is used to move the machine forwards or backwards and steer left or right.

4.8.2 ENGAGING DRIVE

- 1) Before engaging the Traction Drive Positioning System, ensure that the machine is de-coupled from the towing vehicle, the jockey wheel is deployed and fixed securely, and the parking handbrake is fully engaged.
- 2) Check that all Emergency Stops are released (In the 'Out' position), and the Base Key Switch is in the 'On' position. This activates the electrical circuit for the Drive Joystick and Outrigger Controls.
- 3) The Drive Joystick has a single pushbutton located on the handle. Pushing and holding this button allows the power unit to produce hydraulic flow, which is directed to the drive motors. **Do not** operate the Outrigger Selector Lever, as this will divert the hydraulic flow to the Outrigger Controls and deactivate the Traction Drive Positioning System.
- 4) To engage the Traction Drive Positioning System, first check that there are no persons in the immediate area of the drive barrels to prevent a crush injury. Press the Drive Joystick Button and move the separate Control Lever upwards or towards the road tyres (Depending on the machine type). This will activate the engagement cylinder and rotate the traction barrels towards the road tyres. This function is pressure protected, and the lever should be held to allow the cradles to 'push' into the pneumatic tyres for the best grip when positioning the machine. This pressure is set in the factory to 80Bar, and should not need adjustment.
- 5) Once the drive barrels are in position, release the Control Lever and Drive Joystick Button to lock the engagement cylinder in this position. Only then should the parking handbrake be released. The machine will be held securely on the Traction Drive Positioning System.
- 6) To move the machine, push and hold the Drive Joystick Button and move the Drive Joystick in the required direction of travel. The machine moves in relation to the directional movement of the Drive Joystick. To stop the machine, return the Drive Joystick to the centralised 'Off' position, or release the Drive Joystick Button to stop the hydraulic flow. Similarly, the Emergency Stops can be used to halt the machine drive at any time.

4.8.3 DISENGAGING DRIVE

- 1) Ensure that the machine is positioned on flat, level ground and the parking handbrake is fully engaged or wheels chocked securely before the Traction Drive Positioning System is disengaged. Unless the machine has been manoeuvred and coupled to a towing vehicle (as described in the appropriate section of this handbook).
- 2) To disengage the drive barrels, press the button on the Drive Joystick and move the separate Control Lever downwards or away from the road tyres (Depending on the machine type). At this point the engagement cylinder will activate and rotate the drive barrels away from the road tyres. Release the Control Lever once the drive barrels have rotated fully to achieve maximum clearance from the road tyres. This will lock the Traction Drive Positioning System in the retracted position, ready for towing.

4.8.4 SAFETY WARNINGS

- 1) **Do not** tow the machine with the Traction Drive Positioning System engaged onto the road tyres. This would result in serious damage to the machine.
- 2) **Do not** use the Traction Drive Positioning System as a brake. Use the parking handbrake and wheel chocks if necessary.
- 3) **Do not** disengage the Traction Drive Positioning System unless either:
The parking handbrake is fully engaged
The road wheels are chocked securely
Or, the machine is connected directly and securely to a suitable towing vehicle
- 4) **Do not** engage or disengage the Traction Drive Positioning System when the machine is moving.
- 5) **Do not** ride on the machine whilst using the Traction Drive Positioning System or stand inside the machine structure, as serious injury may occur.
- 6) **Do not** drive the machine over long distances using the Traction Drive Positioning System; use a suitable towing vehicle instead. This is especially important when using battery power, as this will reduce the energy available in the batteries for elevating the machine.
- 7) **Always** position the machine on flat, level ground before disengaging the Traction Drive Positioning System.
- 8) **Always** be aware of the environment surrounding the machine. Ensure that appropriate measures are taken to prevent injury to the operator or passers-by. These may include using cones to segregate the vicinity around the machine in pedestrian areas, or using another person to guide the Traction Drive Positioning System operator in areas of limited visibility.
- 9) **Always** stow the stabilisers and use a suitable towing vehicle when moving the machine between work locations.
- 10) **Always** manoeuvre the machine correctly on slopes. If moving the machine up a slope (Ensure slope is less than 10% (5.7°) as stated previously), approach the slope with the tow hitch end of the machine downhill and the rear of the machine uphill, ensuring that the jockey wheel is loaded throughout. This will prevent the machine tipping if a sudden stop is made. To maximise the load on the jockey wheel, lower the tow hitch as far as possible by winding the jockey wheel Handle. Ensure that the jockey wheel can rotate freely around both its axle and its post.

5 Emergency Controls

5.1 GENERAL

CHECKING THE OPERATION OF THE EMERGENCY CONTROLS EVERY DAY AND/OR BEFORE EACH SHIFT IS AN ESSENTIAL PART OF THE OPERATOR'S DUTIES



The operator and all ground personnel must be thoroughly familiar with the location and operation of the EMERGENCY CONTROLS.

5.2 IN THE EVENT OF AN INCAPACITATED OPERATOR

Place the spare key in the ground control station and switch "ON" (clockwise). Then lower on the ground controls as detailed under section 4.3 Ground Control Operation.

5.3 IN THE EVENT OF MACHINE FAILURE

Operate manual hand pump (located under control cover) and lower platform to the ground using either platform or base controls.

Note If the machine is fitted with a cage overload system, and the cage comes into contact with a fixed object whilst operating at height, this would be detected as an overload condition. All power to the machine controls would be lost, requiring the machine to be recovered using the **Emergency Hand Pump**. It is sufficient for the cage to be manoeuvred away from the collision point to release the cage weigh system, thereby restoring normal machine operation. The cage could then be brought down using the controls as described previously.

5.4 INCIDENT NOTIFICATION

It is a mandatory requirement that any accident or incident involving a Niftylift, regardless of whether any party received injury or property was damaged, is reported by telephone directly to Niftylift. Failure to do so may render any warranty on the machine void.

6 Responsibilities

6.1 CHANGES IN OWNERSHIP

When a change of ownership of a Niftylift occurs, it shall be the responsibility of the seller to notify Niftylift direct of the unit, model and serial number and the name and address of the new owner within 60 days. This important step is required so that all future Technical Bulletins are able to reach the registered owner of each machine without delay. Please note warranties are not transferable.

6.2 MANUAL OF RESPONSIBILITIES

You are required by ANSI/SIA 92.2 1990, to read and understand your responsibilities before you use or operate this aerial platform.

Please read the enclosed document, as failure to do so could result in death or serious injury.

Wherever any contradiction may appear, the Manual of Responsibilities shall take precedence over all other documents.

6.3 INSPECTION/SERVICE/PRE-HIRE CHECK LIST

MACHINE SERIAL NO _____

TOWING	PASS	FAIL	N/A
Operation of tow coupling			
Operation of handbrake			
Operation of jockey wheel			
OUTRIGGERS			
Micro-switches secure			
Operation of each micro-switch and klaxon			
Operation of jack control valve and buttons			
Operation of each hydraulic jack			
Operation of boom rest micro-switch			
AXLES, WHEELS AND BRAKES			
Axles slide freely, or are secure			
Wheels are secure, tyre condition acceptable			
Wheel bearings OK			
Mudguards are secure			
Locating pins operate freely and oiled (if applicable)			
Lock bolts are tight			
Wheels spin freely when handbrake is released			
Brakes come on equally when handbrake is applied			
Brake linkages and cables secure			
Brake shoe wear not excessive			
Breakaway cable fitted and operable			
Lighting board fitted, lights function			
Tyre pressure correct			
Wheel nut torque correct			
BASE			
Operation of base control valve and buttons			
Operation of all booms over full range			
Cylinders are silent			
Platform is level over full range			
Booms, levelling rods not damaged or distorted			
Booms, levelling rods, cylinders not fouling			
Hoses not tight, kinked or fouled			
Operation of emergency hand pump			
Traction Drive Positioning System securely attached to axle			

nifty™ TM Series

Operating & Safety Instructions

SLEWING	PASS	FAIL	N/A
Slew assembly and motor are secure			
Worm/wheel mesh correct, no excessive wear			
No end float of worm in housing			
Slew wheel bolts secured			
Slew guards secure			
PLATFORM			
Operation of control valve and buttons			
Operation of all booms over full range			
Cylinders are silent			
Platform levelling over full range			
Slewing smooth over full range			
INTERNAL (POWER PACK)			
Power pack and all components secure			
All cables and terminals secure			
All hose connections secure			
Hoses not kinked or fouled			
Charger/control box secure			
Battery secure			
Electrolyte level and specific gravity			
Charger operation			
Hydraulic oil level			
FINISH			
Swing bolts			
Correct decals, all visible			
Canopy/bonnets			
Grease nipples (Tow coupling, Slew ring)			
LEAK CHECK			
Cylinders (Lift, Outriggers, Telescope, Levelling)			
Control valves			
Check valves			
Power pack/pump			
Slew motor			
Hose connections			

Comments, remedial work required etc;

INSPECTED BY: _____

DATE: / /0