



An Oshkosh Corporation Company

Operation and Safety Manual

Original Instructions - Keep this manual with the machine at all times.

Boom Lift Models

450A Series II

450AJ Series II

510AJ



3121179
May 8, 2012

FOREWORD

This manual is a very important tool! Keep it with the machine at all times.

The purpose of this manual is to provide owners, users, operators, lessors, and lessees with the precautions and operating procedures essential for the safe and proper machine operation for its intended purpose.

Due to continuous product improvements, JLG Industries, Inc. reserves the right to make specification changes without prior notification. Contact JLG Industries, Inc. for updated information.

SAFETY ALERT SYMBOLS AND SAFETY SIGNAL WORDS



This is the Safety Alert Symbol. It is used to alert you to the potential personal injury hazards. Obey all safety messages that follow this symbol to avoid possible injury or death

DANGER

INDICATES AN IMMINENTLY HAZARDOUS SITUATION. IF NOT AVOIDED, WILL RESULT IN SERIOUS INJURY OR DEATH. THIS DECAL WILL HAVE A RED BACKGROUND.

WARNING

INDICATES A POTENTIALLY HAZARDOUS SITUATION. IF NOT AVOIDED, COULD RESULT IN SERIOUS INJURY OR DEATH. THIS DECAL WILL HAVE AN ORANGE BACKGROUND.

CAUTION

INDICATES A POTENTIALLY HAZARDOUS SITUATION. IF NOT AVOIDED, MAY RESULT IN MINOR OR MODERATE INJURY. IT MAY ALSO ALERT AGAINST UNSAFE PRACTICES. THIS DECAL WILL HAVE A YELLOW BACKGROUND.

NOTICE

INDICATES INFORMATION OR A COMPANY POLICY THAT RELATES DIRECTLY OR INDIRECTLY TO THE SAFETY OF PERSONNEL OR PROTECTION OF PROPERTY.

⚠ WARNING

THIS PRODUCT MUST COMPLY WITH ALL SAFETY RELATED BULLETINS. CONTACT JLG INDUSTRIES, INC. OR THE LOCAL AUTHORIZED JLG REPRESENTATIVE FOR INFORMATION REGARDING SAFETY-RELATED BULLETINS WHICH MAY HAVE BEEN ISSUED FOR THIS PRODUCT.

NOTICE

JLG INDUSTRIES, INC. SENDS SAFETY RELATED BULLETINS TO THE OWNER OF RECORD OF THIS MACHINE. CONTACT JLG INDUSTRIES, INC. TO ENSURE THAT THE CURRENT OWNER RECORDS ARE UPDATED AND ACCURATE.

NOTICE

JLG INDUSTRIES, INC. MUST BE NOTIFIED IMMEDIATELY IN ALL INSTANCES WHERE JLG PRODUCTS HAVE BEEN INVOLVED IN AN ACCIDENT INVOLVING BODILY INJURY OR DEATH OF PERSONNEL OR WHEN SUBSTANTIAL DAMAGE HAS OCCURRED TO PERSONAL PROPERTY OR THE JLG PRODUCT.

For:

- Accident Reporting
- Product Safety Publications
- Current Owner Updates
- Questions Regarding Product Safety
- Standards and Regulations Compliance Information
- Questions Regarding Special Product Applications
- Questions Regarding Product Modifications

Contact:

Product Safety and Reliability Department
JLG Industries, Inc.
13224 Fountainhead Plaza
Hagerstown, MD 21742
USA

or Your Local JLG Office
(See addresses on inside of manual cover)

In USA:

Toll Free: 877-JLG-SAFE (877-554-7233)

Outside USA:

Phone: 240-420-2661
Fax: 301-745-3713
E-mail: ProductSafety@JLG.com

REVISION LOG

Original Issue	- January 1, 2003
Revised	- April 24, 2003
Revised	- August 26, 2003
Revised	- June 15, 2004
Revised	- May 4, 2005
Revised	- February 8, 2006
Revised	- May 22, 2006
Revised	- August 2, 2007
Revised	- January 11, 2008
Revised	- October 29, 2009
Revised	- November 25, 2009
Revised	- July 30, 2010
Revised	- September 8, 2011
Revised	- March 5, 2012
Revised	- May 8, 2012

SECTION - PARAGRAPH, SUBJECT	PAGE
SECTION - 1 - SAFETY PRECAUTIONS	
1.1 GENERAL	1-1
1.2 PRE-OPERATION	1-1
Operator Training and Knowledge	1-1
Workplace Inspection	1-2
Machine Inspection	1-2
1.3 OPERATION	1-3
General	1-3
Trip and Fall Hazards	1-3
Electrocution Hazards	1-4
Tipping Hazards	1-6
Crushing and Collision Hazards	1-7
1.4 TOWING, LIFTING, AND HAULING	1-8
1.5 ADDITIONAL HAZARDS / SAFETY	1-9
SECTION - 2 - USER RESPONSIBILITIES, MACHINE PREPARATION, AND INSPECTION	
2.1 PERSONNEL TRAINING	2-1
Operator Training	2-1
Training Supervision	2-1
Operator Responsibility	2-1
2.2 PREPARATION, INSPECTION, AND MAINTENANCE	2-2
Pre-Start Inspection	2-4
Function Check	2-5

SECTION - PARAGRAPH, SUBJECT	PAGE
GENERAL	2-9
2.3 OSCILLATING AXLE LOCKOUT TEST (IF EQUIPPED)	2-11
SECTION - 3 - MACHINE CONTROLS AND INDICATORS	
3.1 GENERAL	3-1
3.2 CONTROLS AND INDICATORS	3-1
Ground Control Station	3-1
Ground Control Indicator Panel	3-5
Platform Control Station	3-9
Platform Control Indicator Panel	3-14
SECTION - 4 - MACHINE OPERATION	
4.1 DESCRIPTION	4-1
4.2 OPERATING CHARACTERISTICS AND LIMITATIONS	4-1
Capacities	4-1
Stability	4-2
4.3 ENGINE OPERATION	4-2
Starting Procedure	4-2
Shutdown Procedure	4-3
4.4 TRAVELING (DRIVING)	4-5
Traveling Forward and Reverse	4-7

TABLE OF CONTENTS

SECTION - PARAGRAPH, SUBJECT	PAGE
4.5 STEERING	4-7
4.6 PLATFORM	4-7
Platform Level Adjustment	4-7
Platform Rotation	4-7
4.7 BOOM	4-8
Swinging the Boom	4-8
Raising and Lowering the Lower and Mid Boom	4-8
Raising and Lowering the Main (Upper) Boom	4-8
Telescoping the Main Boom	4-8
4.8 FUNCTION SPEED CONTROL	4-9
4.9 AUXILIARY PUMP	4-9
4.10 OSCILLATING AXLE LOCKOUT TEST (IF EQUIPPED)	4-9
4.11 SHUT DOWN AND PARK	4-10
4.12 LIFTING AND TIE DOWN	4-10
Lifting	4-10
Tie Down	4-10
4.13 TOWING	4-12
Prior to Towing	4-12
4.14 DUAL FUEL SYSTEM (GAS ENGINE ONLY)	4-13
Changing From Gasoline to LP Gas	4-13
Changing From LP Gas to Gasoline	4-13

SECTION - PARAGRAPH, SUBJECT	PAGE
SECTION - 5 - EMERGENCY PROCEDURES	
5.1 GENERAL	5-1
5.2 INCIDENT NOTIFICATION	5-1
5.3 EMERGENCY OPERATION	5-2
Operator Unable to Control Machine	5-2
Platform or Boom Caught Overhead	5-2
5.4 EMERGENCY TOWING PROCEDURES	5-2
SECTION - 6 - GENERAL SPECIFICATIONS & OPERATOR MAINTENANCE	
6.1 INTRODUCTION	6-1
6.2 OPERATING SPECIFICATIONS AND PERFORMANCE DATA	6-1
Reach Specifications	6-3
Dimensional Data	6-4
Chassis	6-4
Capacities	6-5
Tires	6-5
Engine	6-6
Major Component Weights	6-9
Hydraulic Oil	6-9
Serial Number Location	6-13
6.3 OPERATOR MAINTENANCE	6-25
6.4 TIRES & WHEELS	6-37
Tire Inflation	6-37

SECTION - PARAGRAPH, SUBJECT	PAGE
Tire Damage	6-37
Tire Replacement	6-37
Wheel Replacement	6-38
Wheel Installation	6-38
6.5 DRAINING OIL BUILD UP FROM THE PROPANE REG- ULATOR (PRIOR TO S/N 0300137808)	6-40
6.6 PROPANE FUEL FILTER REPLACEMENT.	6-41
Removal	6-41
Installation.	6-43
6.7 PROPANE FUEL SYSTEM PRESSURE RELIEF	6-43
6.8 SUPPLEMENTAL INFORMATION	6-44

SECTION - 7 - INSPECTION AND REPAIR LOG

SECTION - PARAGRAPH, SUBJECT	PAGE
LIST OF FIGURES	
2-1. Basic Nomenclature - Sheet 1 of 2	2-6
2-2. Basic Nomenclature - Sheet 2 of 2	2-7
2-3. Daily Walk-Around Inspection - Sheet 1 of 3	2-8
2-4. Daily Walk-Around Inspection - Sheet 2 of 3	2-9
2-5. Daily Walk-Around Inspection - Sheet 3 of 3	2-10
3-1. Ground Control Station - A Models	3-2
3-1. Ground Control Station - AJ Models	3-3
3-2. Ground Control Indicator Panel - Sheet 1 of 2	3-6
3-3. Ground Control Indicator Panel - Sheet 2 of 2	3-7
3-4. Platform Control Console	3-10
3-5. Platform Control Console - w/Drive Orientation	3-11
3-6. Platform Control Indicator Panel - Sheet 1 of 2	3-16
3-7. Platform Control Indicator Panel - Sheet 2 of 2	3-17
3-8. Platform Control Indicator Panel - w/Drive Orientation.	3-18
4-1. Position of Least Forward Stability	4-4
4-2. Position of Least Backward Stability	4-5
4-3. Grade and Side Slopes	4-6
4-4. Lifting and Tie Down Chart	4-11
4-5. Drive Disconnect Hub	4-12
4-6. Decal Installation - Sheet 1 of 6	4-14
4-7. Decal Installation - Sheet 2 of 6	4-15
4-8. Decal Installation - Sheet 3 of 6	4-16
4-9. Decal Installation - Sheet 4 of 6	4-17

TABLE OF CONTENTS

SECTION - PARAGRAPH, SUBJECT	PAGE
4-10. Decal Installation - Sheet 5 of 6	4-18
4-11. Decal Installation - Sheet 6 of 6	4-19
6-1. Serial Number Locations	6-13
6-2. Engine Operating Temperature Specifications - Deutz - Sheet 1 of 2	6-14
6-3. Engine Operating Temperature Specifications - Deutz - Sheet 2 of 2	6-15
6-4. Engine Operating Temperature Specifications - Ford - Sheet 1 of 2	6-16
6-5. Engine Operating Temperature Specifications - Ford - Sheet 2 of 2	6-17
6-6. Engine Operating Temperature Specifications - Caterpillar - Sheet 1 of 2	6-18
6-7. Engine Operating Temperature Specifications - Caterpillar - Sheet 2 of 2	6-19
6-8. Engine Operating Temperature Specifications - GM - Sheet 1 of 2	6-20
6-9. Engine Operating Temperature Specifications - GM - Sheet 2 of 2	6-21
6-10. Engine Operating Temperature Specifications - Perkins - Sheet 1 of 2	6-22
6-11. Engine Operating Temperature Specifications - Perkins - Sheet 2 of 2	6-23
6-12. Operator Maintenance and Lubrication Diagram .	6-24
6-13. Filter Lock Assembly	6-42

SECTION - PARAGRAPH, SUBJECT	PAGE
LIST OF TABLES	
1-1 Minimum Approach Distances (M.A.D.)	1-5
1-2 Beaufort Scale (For Reference Only)	1-10
2-1 Inspection and Maintenance Table	2-3
4-1 Decal Legend - Prior to S/N 0300141424	4-20
4-2 Decal Legend - S/N 0300141424 to Present	4-23
6-1 Operating Specifications - 450A/450AJ - Prior to S/N 0300141424	6-1
6-2 Operating Specifications - 450A/450AJ - S/N 0300141424 to Present	6-2
6-3 Operating Specifications - 510AJ	6-3
6-4 Reach Specifications - 450	6-3
6-5 Reach Specifications - 510	6-3
6-6 Dimensional Data - 450	6-4
6-7 Dimensional Data - 510	6-4
6-8 Chassis Specifications - 450	6-4
6-9 Chassis Specifications - 510	6-5
6-10 Capacities	6-5
6-11 Tires	6-5
6-12 Ford LRG-425 (Gas or Dual Fuel)	6-6
6-13 Deutz F3M1011F	6-6
6-14 Deutz F3M2011F/D2011L03	6-7
6-15 Caterpillar 3024/C2.2	6-7
6-16 GM 3.0L	6-8
6-17 Perkins 404D-22	6-8

TABLE OF CONTENTS

SECTION - PARAGRAPH, SUBJECT	PAGE	SECTION - PARAGRAPH, SUBJECT	PAGE
6-18 Component Weights - 450	6-9		
6-19 Component Weights - 510	6-9		
6-20 Hydraulic Oil	6-9		
6-21 Mobilfluid 424 Specs	6-10		
6-22 Mobil DTE 13M Specs	6-10		
6-23 UCon Hydrolube HP-5046	6-11		
6-24 Mobil EAL H 46 Specs	6-11		
6-25 Exxon Univis HVI 26 Specs	6-12		
6-26 Quintolubric 888-46	6-12		
6-27 Lubrication Specifications	6-25		
6-28 Wheel Torque Chart	6-39		
7-1 Inspection and Repair Log	7-1		

TABLE OF CONTENTS

SECTION - PARAGRAPH, SUBJECT	PAGE	SECTION - PARAGRAPH, SUBJECT	PAGE
-------------------------------------	-------------	-------------------------------------	-------------

This page left blank intentionally.

SECTION 1. SAFETY PRECAUTIONS

1.1 GENERAL

This section outlines the necessary precautions for proper and safe machine operation and maintenance. For proper machine use, it is mandatory that a daily routine is established based on the content of this manual. A maintenance program, using the information provided in this manual and the Service and Maintenance Manual, must also be established by a qualified person and followed to ensure the machine is safe to operate.

The owner/user/operator/lessor/lessee of the machine should not operate the machine until this manual has been read, training is accomplished, and operation of the machine has been completed under the supervision of an experienced and qualified operator.

If there are any questions with regard to safety, training, inspection, maintenance, application, and operation, please contact JLG Industries, Inc. (“JLG”).

WARNING

FAILURE TO COMPLY WITH THE SAFETY PRECAUTIONS LISTED IN THIS MANUAL COULD RESULT IN MACHINE DAMAGE, PROPERTY DAMAGE, PERSONAL INJURY OR DEATH.

1.2 PRE-OPERATION

Operator Training and Knowledge

- Read and understand this manual before operating the machine.

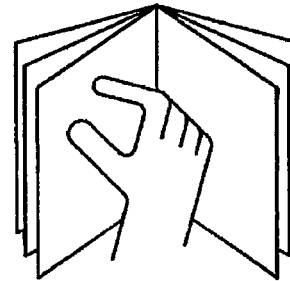

- Do not operate this machine until complete training is performed by authorized persons.
- Only authorized and qualified personnel can operate the machine.

SECTION 1 - SAFETY PRECAUTIONS

- Read, understand, and obey all DANGERS, WARNINGS, CAUTIONS, and operating instructions on the machine and in this manual.
- Use the machine in a manner which is within the scope of its intended application set by JLG.
- All operating personnel must be familiar with the emergency controls and emergency operation of the machine as specified in this manual.
- Read, understand, and obey all applicable employer, local, and governmental regulations as they pertain to operation of the machine.

Workplace Inspection

- The operator is to take safety measures to avoid all hazards in the work area prior to machine operation.
- Do not operate or raise the platform while on trucks, trailers, railway cars, floating vessels, scaffolds or other equipment unless approved in writing by JLG.
- Do not operate the machine in hazardous environments unless approved for that purpose by JLG.
- Be sure that the ground conditions are able to support the maximum load shown on the decals located on the machine.

Machine Inspection

- Before machine operation, perform inspections and functional checks. Refer to Section 2 of this manual for detailed instructions.
- Do not operate this machine until it has been serviced and maintained according to requirements specified in the Service and Maintenance Manual.
- Be sure the footswitch and all other safety devices are operating properly. Modification of these devices is a safety violation.

WARNING

MODIFICATION OR ALTERATION OF AN AERIAL WORK PLATFORM SHALL BE MADE ONLY WITH WRITTEN PERMISSION FROM THE MANUFACTURER

- Do not operate any machine on which safety or instruction placards or decals are missing or illegible.
- Avoid any buildup of debris on the platform floor. Keep mud, oil, grease, and other slippery substances from footwear and platform floor.

1.3 OPERATION

General

- Do not use the machine for any purpose other than positioning personnel, their tools, and equipment.
 - Never operate a machine that is not working properly. If a malfunction occurs, shut down the machine.
 - Never slam a control switch or lever through neutral to an opposite direction. Always return switch to neutral and stop before moving the switch to the next function. Operate controls with slow and even pressure.
 - Hydraulic cylinders should never be left fully extended or fully retracted before shutdown or for long periods of time.
 - Do not allow personnel to tamper with or operate the machine from the ground with personnel in the platform, except in an emergency.
 - Do not carry materials directly on platform railing. Contact JLG for approved material handling accessories.
 - When two or more persons are in the platform, the operator shall be responsible for all machine operations.
 - Always ensure that power tools are properly stowed and never left hanging by their cord from the platform work area.
- Supplies or tools which extend outside the platform are prohibited unless approved by JLG.
 - When driving, always position boom over rear axle in line with the direction of travel. Remember, if boom is over the front axle, steer and drive functions will be reversed.
 - Do not assist a stuck or disabled machine by pushing, pulling, or by using boom functions. Only pull the unit from the tie-down lugs on the chassis.
 - Do not place boom or platform against any structure to steady the platform or to support the structure.
 - Stow boom and shut off all power before leaving machine.

Trip and Fall Hazards

During operation, occupants in the platform must wear a full body harness with a lanyard attached to an authorized lanyard anchorage point. Attach only one (1) lanyard per lanyard anchorage point.

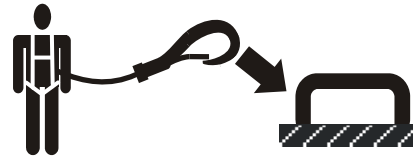

SECTION 1 - SAFETY PRECAUTIONS

- Before operating the machine, make sure all gates are closed and fastened in their proper position.

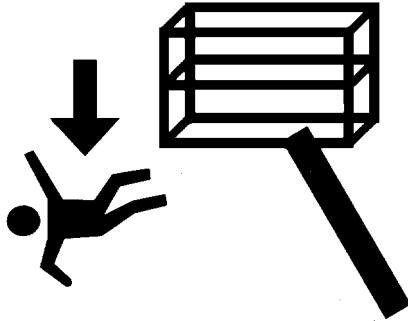

- Keep both feet firmly positioned on the platform floor at all times. Never use ladders, boxes, steps, planks, or similar items on platform to provide additional reach.
- Never use the boom assembly to enter or leave the platform.

- Use extreme caution when entering or leaving platform. Be sure that the boom is fully lowered. It may be necessary to telescope out to position the platform closer to the ground for entry/exit. Face the machine, maintain “three point contact” with the machine, using two hands and one foot or two feet and one hand during entry and exit.

Electrocution Hazards

- This machine is not insulated and does not provide protection from contact or proximity to electrical current.

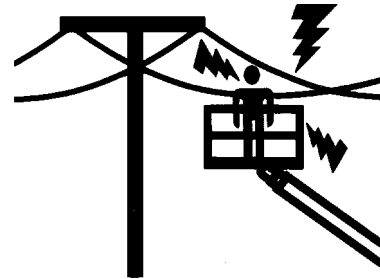

SECTION 1 - SAFETY PRECAUTIONS

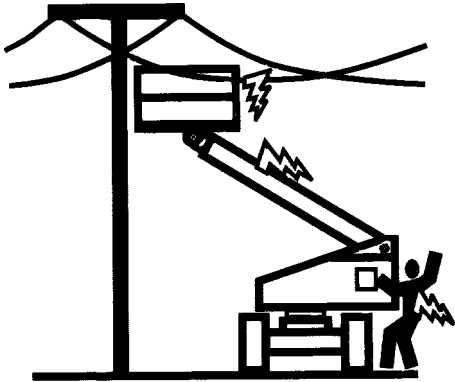

- Maintain distance from electrical lines, apparatus, or any energized (exposed or insulated) parts according to the Minimum Approach Distance (MAD) as shown in Table 1-1.
- Allow for machine movement and electrical line swaying.

Table 1-1. Minimum Approach Distances (M.A.D.)

Voltage Range (Phase to Phase)	MINIMUM APPROACH DISTANCE in Feet (Meters)
0 to 50 KV	10 (3)
Over 50KV to 200 KV	15 (5)
Over 200 KV to 350 KV	20 (6)
Over 350 KV to 500 KV	25 (8)
Over 500 KV to 750 KV	35 (11)
Over 750 KV to 1000 KV	45 (14)

NOTE: *This requirement shall apply except where employer, local or governmental regulations are more stringent.*

- Maintain a clearance of at least 10 ft. (3m) between any part of the machine and its occupants, their tools, and their equipment from any electrical line or apparatus carrying up to 50,000 volts. One foot additional clearance is required for every additional 30,000 volts or less.

SECTION 1 - SAFETY PRECAUTIONS

- The minimum approach distance may be reduced if insulating barriers are installed to prevent contact, and the barriers are rated for the voltage of the line being guarded. These barriers shall not be part of (or attached to) the machine. The minimum approach distance shall be reduced to a distance within the designed working dimensions of the insulating barrier. This determination shall be made by a qualified person in accordance with the employer, local, or governmental requirements for work practices near energized equipment

⚠ DANGER

DO NOT MANEUVER MACHINE OR PERSONNEL INSIDE PROHIBITED ZONE (MAD). ASSUME ALL ELECTRICAL PARTS AND WIRING ARE ENERGIZED UNLESS KNOWN OTHERWISE.

Tipping Hazards

- The user should be familiar with the surface before driving. Do not exceed the allowable sideslope and grade while driving.

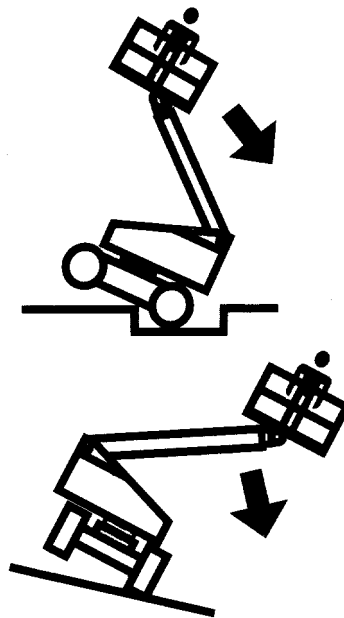

- Do not elevate platform or drive with platform elevated while on a sloping, uneven, or soft surface.
- Before driving on floors, bridges, trucks, and other surfaces, check allowable capacity of the surfaces.
- Never exceed the maximum platform capacity. Distribute loads evenly on platform floor.
- Do not raise the platform or drive from an elevated position unless the machine is on firm, level and smooth surfaces.
- Keep the chassis of the machine at least 2 ft. (0.6m) from holes, bumps, drop-offs, obstructions, debris, concealed holes, and other potential hazards on the floor/surface.
- Do not push or pull any object with the boom.
- Never attempt to use the machine as a crane. Do not tie-off machine to any adjacent structure.
- Do not operate the machine when wind conditions exceed 28 mph (12.5 m/s). Refer to Table 1-2, Beaufort Scale (For Reference Only).
- Do not increase the surface area of the platform or the load. Increase of the area exposed to the wind will decrease stability.
- Do not increase the platform size with unauthorized deck extensions or attachments.

- If boom assembly or platform is in a position that one or more wheels are off the ground, all persons must be removed before attempting to stabilize the machine. Use cranes, forklift trucks, or other appropriate equipment to stabilize machine.

Crushing and Collision Hazards

- Approved head gear must be worn by all operating and ground personnel.
- Check work area for clearances overhead, on sides, and bottom of platform when lifting or lowering platform, and driving.

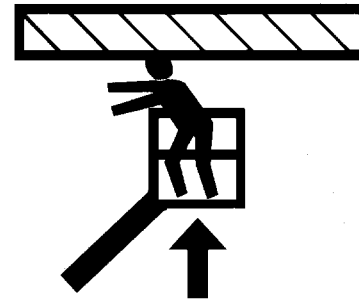

- During operation, keep all body parts inside platform railing.

SECTION 1 - SAFETY PRECAUTIONS

- Use the boom functions, not the drive function, to position the platform close to obstacles.
- Always post a lookout when driving in areas where vision is obstructed.
- Keep non-operating personnel at least 6 ft. (1.8m) away from machine during all driving and swing operations.
- Limit travel speed according to conditions of ground surface, congestion, visibility, slope, location of personnel, and other factors which may cause collision or injury to personnel.
- Be aware of stopping distances in all drive speeds. When driving in high speed, switch to low speed before stopping. Travel grades in low speed only.
- Do not use high speed drive in restricted or close quarters or when driving in reverse.
- Exercise extreme caution at all times to prevent obstacles from striking or interfering with operating controls and persons in the platform.
- Be sure that operators of other overhead and floor level machines are aware of the aerial work platform's presence. Disconnect power to overhead cranes.
- Warn personnel not to work, stand, or walk under a raised boom or platform. Position barricades on floor if necessary.

1.4 TOWING, LIFTING, AND HAULING

- Never allow personnel in platform while towing, lifting, or hauling.
- This machine should not be towed, except in the event of emergency, malfunction, power failure, or loading/unloading. Refer to the Emergency Procedures section of this manual for emergency towing procedures.
- Ensure boom is in the stowed position and the turntable locked prior to towing, lifting or hauling. The platform must be completely empty of tools.
- When lifting machine, lift only at designated areas of the machine. Lift the unit with equipment of adequate capacity.
- Refer to the Machine Operation section of this manual for lifting information.

1.5 ADDITIONAL HAZARDS / SAFETY

- Do not use machine as a ground for welding.
- When performing welding or metal cutting operations, precautions must be taken to protect the chassis from direct exposure to weld and metal cutting spatter.
- Do not refuel the machine with the engine running.
- Battery fluid is highly corrosive. Avoid contact with skin and clothing at all times.
- Charge batteries only in a well ventilated area.

SECTION 1 - SAFETY PRECAUTIONS

NOTICE

DO NOT OPERATE THE MACHINE WHEN WIND CONDITIONS EXCEED 28 MPH (12.5 M/S).

Table 1-2. Beaufort Scale (For Reference Only)

Beaufort Number	Wind Speed		Description	Land Conditions
	mph	m/s		
0	0	0-0.2	Calm	Calm. Smoke rises vertically
1	1-3	0.3-1.5	Light air	Wind motion visible in smoke
2	4-7	1.6-3.3	Light breeze	Wind felt on exposed skin. Leaves rustle
3	8-12	3.4-5.4	Gentle breeze	Leaves and smaller twigs in constant motion
4	13-18	5.5-7.9	Moderate breeze	Dust and loose paper raised. Small branches begin to move.
5	19-24	8.0-10.7	Fresh breeze	Smaller trees sway.
6	25-31	10.8-13.8	Strong breeze	Large branches in motion. Whistling heard in overhead wires. Umbrella use becomes difficult.
7	32-38	13.9-17.1	Near Gale/Moderate Gale	Whole trees in motion. Effort needed to walk against the wind.
8	39-46	17.2-20.7	Fresh Gale	Twigs broken from trees. Cars veer on road.
9	47-54	20.8-24.4	Strong Gale	Light structure damage.

SECTION 2. USER RESPONSIBILITIES, MACHINE PREPARATION, AND INSPECTION

2.1 PERSONNEL TRAINING

The aerial platform is a personnel handling device; so it is necessary that it be operated and maintained only by trained personnel.

Persons under the influence of drugs or alcohol or who are subject to seizures, dizziness or loss of physical control must not operate this machine.

Operator Training

Operator training must cover:

1. Use and limitations of the controls in the platform and at the ground, emergency controls and safety systems.
2. Control labels, instructions, and warnings on the machine.
3. Rules of the employer and government regulations.
4. Use of approved fall protection device.
5. Enough knowledge of the mechanical operation of the machine to recognize a malfunction or potential malfunction.

6. The safest means to operate the machine where overhead obstructions, other moving equipment, and obstacles, depressions, holes, dropoffs.
7. Means to avoid the hazards of unprotected electrical conductors.
8. Specific job requirements or machine application.

Training Supervision

Training must be done under the supervision of a qualified person in an open area free of obstructions until the trainee has developed the ability to safely control and operate the machine.

Operator Responsibility

The operator must be instructed that he/she has the responsibility and authority to shut down the machine in case of a malfunction or other unsafe condition of either the machine or the job site.

2.2 PREPARATION, INSPECTION, AND MAINTENANCE

The following table covers the periodic machine inspections and maintenance recommended by JLG Industries, Inc. Consult local regulations for further requirements for aerial work platforms. The frequency of inspections and maintenance must be increased as necessary when the machine is used in a harsh or hostile environment, if the machine is used with increased frequency, or if the machine is used in a severe manner.

NOTICE

JLG INDUSTRIES, INC. RECOGNIZES A FACTORY-QUALIFIED SERVICE TECHNICIAN AS A PERSON WHO HAS SUCCESSFULLY COMPLETED THE JLG SERVICE TRAINING SCHOOL FOR THE SPECIFIC JLG PRODUCT MODEL.

SECTION 2 - USER RESPONSIBILITIES, MACHINE PREPARATION, AND INSPECTION

Table 2-1. Inspection and Maintenance Table

Type	Frequency	Primary Responsibility	Service Qualification	Reference
Pre-Start Inspection	Before using each day; or whenever there's an Operator change.	User or Operator	User or Operator	Operator and Safety Manual
Pre-Delivery Inspection (See Note)	Before each sale, lease, or rental delivery.	Owner, Dealer, or User	Qualified JLG Mechanic	Service and Maintenance Manual and applicable JLG inspection form
Frequent Inspection (See Note)	In service for 3 months or 150 hours, whichever comes first; or Out of service for a period of more than 3 months; or Purchased used.	Owner, Dealer, or User	Qualified JLG Mechanic	Service and Maintenance Manual and applicable JLG inspection form
Annual Machine Inspection (See Note)	Annually, no later than 13 months from the date of prior inspection.	Owner, Dealer, or User	Factory-Qualified Service Technician (Recommended)	Service and Maintenance Manual and applicable JLG inspection form
Preventative Maintenance	At intervals as specified in the Service and Maintenance Manual.	Owner, Dealer, or User	Qualified JLG Mechanic	Service and Maintenance Manual
NOTE: Inspection forms are available from JLG. Use the Service and Maintenance Manual to perform inspections.				

SECTION 2 - USER RESPONSIBILITIES, MACHINE PREPARATION, AND INSPECTION

Pre-Start Inspection

The Pre-Start Inspection should include each of the following:

1. **Cleanliness** – Check all surfaces for leakage (oil, fuel, or battery fluid) or foreign objects. Report any leakage to the proper maintenance personnel.
2. **Decals and Placards** – Check all for cleanliness and legibility. Make sure none of the decals and placards are missing. Make sure all illegible decals and placards are cleaned or replaced.
3. **Operators and Safety Manuals** – Make sure a copy of the Operator and Safety Manual, EMI Safety Manual (Domestic only), and ANSI Manual of Responsibilities (Domestic only) is enclosed in the weather resistant storage container.
4. **“Walk-Around” Inspection** – Refer to Figure 2-3. and Figure 2-4.
5. **Battery** – Charge as required.
6. **Fuel** (Combustion Engine Powered Machines) – Add the proper fuel as necessary.
7. **Engine Oil Supply** - Ensure the engine oil level is at the Full mark on the dipstick and the filler cap is secure.
8. **Hydraulic Oil** – Check the hydraulic oil level. Ensure hydraulic oil is added as required.
9. **Accessories/Attachments** - Reference the Operator and Safety Manual of each attachment for accessory installed upon the machine for specific inspection, operation, and maintenance instructions.
10. **Function Check** – Once the “Walk-Around” Inspection is complete, perform a functional check of all systems in an area free of overhead and ground level obstructions. Refer to Section 4 for more specific instructions.

WARNING

IF THE MACHINE DOES NOT OPERATE PROPERLY, TURN OFF THE MACHINE IMMEDIATELY! REPORT THE PROBLEM TO THE PROPER MAINTENANCE PERSONNEL. DO NOT OPERATE THE MACHINE UNTIL IT IS DECLARED SAFE FOR OPERATION.

Function Check

Perform the Function Check as follows:

1. From the ground control panel with no load in the platform:
 - a. Check that all guards protecting the switches or locks are in place;
 - b. Operate all functions and check boom limit switches; drive speed should switch to creep mode if lower boom is elevated or main boom is above horizontal.
 - c. Check auxiliary power (or manual descent);
 - d. Ensure that all machine functions are disabled when the Emergency Stop Button is activated.
2. From the platform control console:
 - a. Ensure that the control console is firmly secured in the proper location;
 - b. Check that all guards protecting the switches or locks are in place;
 - c. Operate all functions and check all limiting and cut-out switches;
 - d. Ensure that all machine functions are disabled when the Emergency Stop Button is pushed in.
3. With the platform in the transport (stowed) position:
 - a. Drive the machine on a grade, not to exceed the rated gradeability, and stop to ensure the brakes hold;
 - b. Check the tilt sensor alarm to ensure proper operation.

SECTION 2 - USER RESPONSIBILITIES, MACHINE PREPARATION, AND INSPECTION

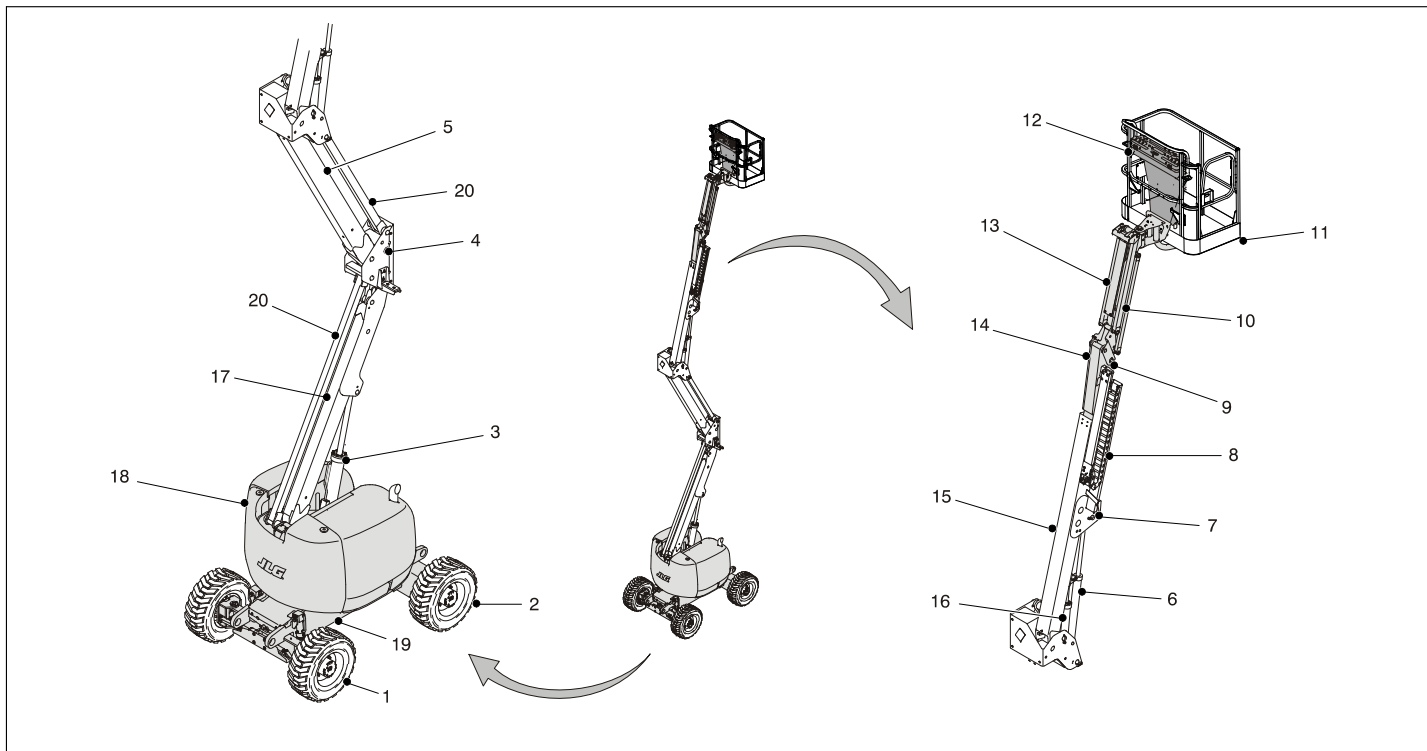

Figure 2-1. Basic Nomenclature - Sheet 1 of 2

SECTION 2 - USER RESPONSIBILITIES, MACHINE PREPARATION, AND INSPECTION

1. Steer Wheels
2. Drive Wheels
3. Lower Lift Cylinder
4. Lower Upright
5. Mid Boom
6. Upper Lift Cylinder
7. Main Boom Assembly
8. Power Track
9. Level Cylinder
10. Jib Cylinder
11. Platform
12. Platform Console
13. Jib
14. Fly Boom
15. Base Boom
16. Master Cylinder
17. Tower or Lower Boom
18. Turntable
19. Frame
20. Tower Link

Figure 2-2. Basic Nomenclature - Sheet 2 of 2

SECTION 2 - USER RESPONSIBILITIES, MACHINE PREPARATION, AND INSPECTION

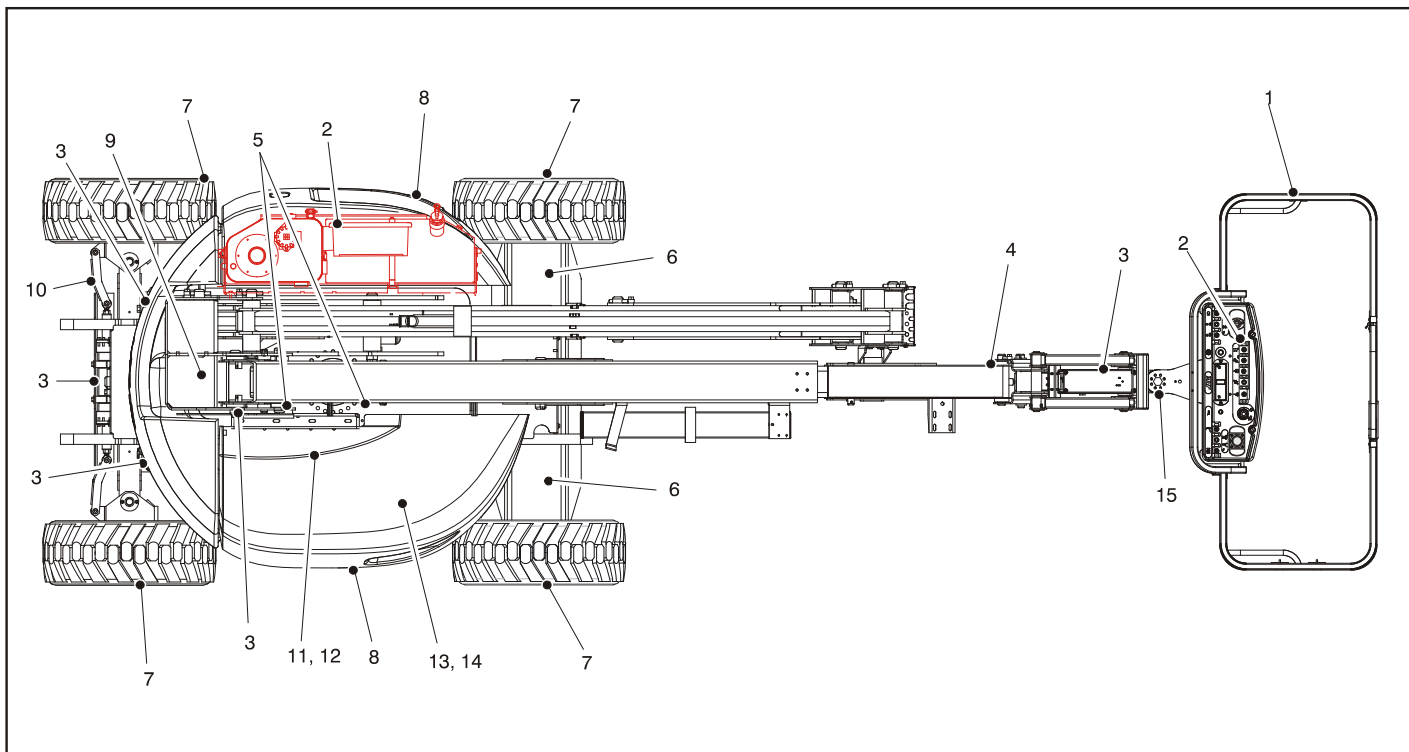

Figure 2-3. Daily Walk-Around Inspection - Sheet 1 of 3

SECTION 2 - USER RESPONSIBILITIES, MACHINE PREPARATION, AND INSPECTION

GENERAL

Begin the "Walk-Around Inspection" at Item 1, as noted on the diagram. Continue to the right (counterclockwise viewed from top) checking each item in sequence for the conditions listed in the following checklist.

WARNING

TO AVOID POSSIBLE INJURY, BE SURE MACHINE POWER IS OFF.

DO NOT OPERATE MACHINE UNTIL ALL MALFUNCTIONS HAVE BEEN CORRECTED.

INSPECTION NOTE: *On all components, make sure there are no loose or missing parts, that they are securely fastened, and no visible damage, leaks or excessive wear exists in addition to any other criteria mentioned.*

- 1. Platform Assembly and Gate** - Lockbolts in place. Footswitch works properly, not modified, disabled or blocked. Latch, stop, and hinges in working condition.
- 2. Platform & Ground Control Consoles** - Switches and levers return to neutral, decals/placards secure and legible, control markings legible.
- 3. All Hydraulic Cylinders** - No visible damage; pivot pins and hydraulic hoses undamaged, not leaking.
- 4. Boom Sections/Uprights/Turntable** - See Inspection Note.
- 5. Boom Limit Switches** - Switches operate properly.
- 6. Drive Motor, Brake, and Hub** - No evidence of leakage.
- 7. Wheel/Tire Assemblies** - Properly secured, no missing lug nuts, proper inflation (pneumatic).
- 8. Hood Assemblies** - See Inspection Note.

Figure 2-4. Daily Walk-Around Inspection - Sheet 2 of 3

SECTION 2 - USER RESPONSIBILITIES, MACHINE PREPARATION, AND INSPECTION

9. **Oscillation Lockout Valve (If Equipped) (450 Models Prior to S/N 0300077285, 510 Models Prior to S/N 1300000353)** - Check the lockout valve plunger in the depressed position. Swing the turntable until the axle lockout bracket passes the plunger and make sure the plunger is fully extended as shown below

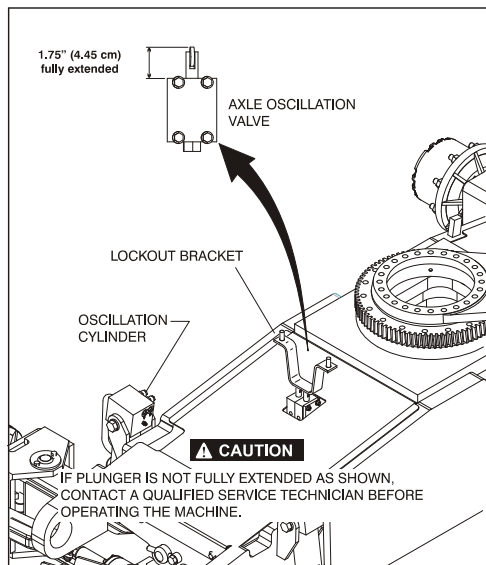

Figure 2-5. Daily Walk-Around Inspection - Sheet 3 of 3

10. **Tie Rod Ends and Steering Spindles** - See Inspection Note.
11. **Turntable Bearing** - Evidence of proper lubrication. No evidence of loose bolts or looseness between bearing and machine.
12. **Swing Motor and Worm Gear** - Evidence of proper lubrication; No evidence of damage.
13. **Auxiliary Hydraulic Pump** - See Inspection Note.
14. **Main Hydraulic Pump** - See Inspection Note.
15. **Platform Rotator** - See Inspection Note.

2.3 OSCILLATING AXLE LOCKOUT TEST (IF EQUIPPED)

NOTICE

LOCKOUT SYSTEM TEST MUST BE PERFORMED QUARTERLY, ANY TIME A SYSTEM COMPONENT IS REPLACED, OR WHEN IMPROPER SYSTEM OPERATION IS SUSPECTED.

NOTE: *Ensure boom is fully retracted, lowered, and centered between drive wheels prior to beginning lockout cylinder test.*

1. Place a 6 inches (15.2 cm) high block with ascension ramp in front of left front wheel.
2. From platform control station, start engine.
3. Place the Drive control lever to the forward position and carefully drive machine up ascension ramp until left front wheel is on top of block.
4. Carefully activate Swing control lever and position boom over right side of machine.
5. With boom over right side of machine, place Drive control lever to Reverse and drive machine off of block and ramp.
6. Have an assistant check to see that left front or right rear wheel remains elevated in position off of ground.
7. Carefully activate Swing control lever and return boom to stowed position (centered between drive wheels). When boom reaches center, stowed position, lockout cylinders should release and allow wheel to rest on ground, it may be necessary to activate Drive to release cylinders.
8. Place the 6 inches (15.2 cm) high block with ascension ramp in front of right front wheel.
9. Place Drive control lever to Forward and carefully drive machine up ascension ramp until right front wheel is on top of block.
10. With boom over left side of machine, place Drive control lever to Reverse and drive machine off of block and ramp.

SECTION 2 - USER RESPONSIBILITIES, MACHINE PREPARATION, AND INSPECTION

11. Have an assistant check to see that right front or left rear wheel remains elevated in position off of ground.
12. Carefully activate Swing control lever and return boom to stowed position (centered between drive wheels). When boom reaches center, stowed position, lockout cylinders should release and allow wheel to rest on ground, it may be necessary activate Drive to release cylinders.
13. If lockout cylinders do not function properly, have qualified personnel correct the malfunction prior to any further operation.

SECTION 3. MACHINE CONTROLS AND INDICATORS

3.1 GENERAL

NOTICE

THE MANUFACTURER HAS NO DIRECT CONTROL OVER MACHINE APPLICATION AND OPERATION. THE USER AND OPERATOR ARE RESPONSIBLE FOR CONFORMING WITH GOOD SAFETY PRACTICES.

This section provides the necessary information needed to understand control functions.

3.2 CONTROLS AND INDICATORS

Ground Control Station

NOTE: *If equipped, the Function Enable switch must be held down in order to operate Telescope, Swing, Tower Lift, Main Lift, Jib Lift, Platform Level Override, and Platform Rotate functions.*



WARNING

DO NOT OPERATE FROM GROUND CONTROL STATION WITH PERSONNEL IN THE PLATFORM EXCEPT IN AN EMERGENCY.

PERFORM AS MANY PRE-OPERATIONAL CHECK AND INSPECTIONS FROM GROUND CONTROLS AS POSSIBLE.

1. Platform Rotate

A three position switch controls rotation of the platform.

WARNING

ONLY USE THE PLATFORM LEVELING OVERRIDE FUNCTION FOR SLIGHT LEVELING OF THE PLATFORM. INCORRECT USE COULD CAUSE THE LOAD/OCCUPANTS TO SHIFT OR FALL. FAILURE TO DO SO COULD RESULT IN DEATH OR SERIOUS INJURY.

2. Platform Leveling Override

A three position switch allows the operator to adjust the automatic self leveling system. This switch is used to adjust the platform level in situations such as ascending/descending a grade.

SECTION 3 - MACHINE CONTROLS AND INDICATORS

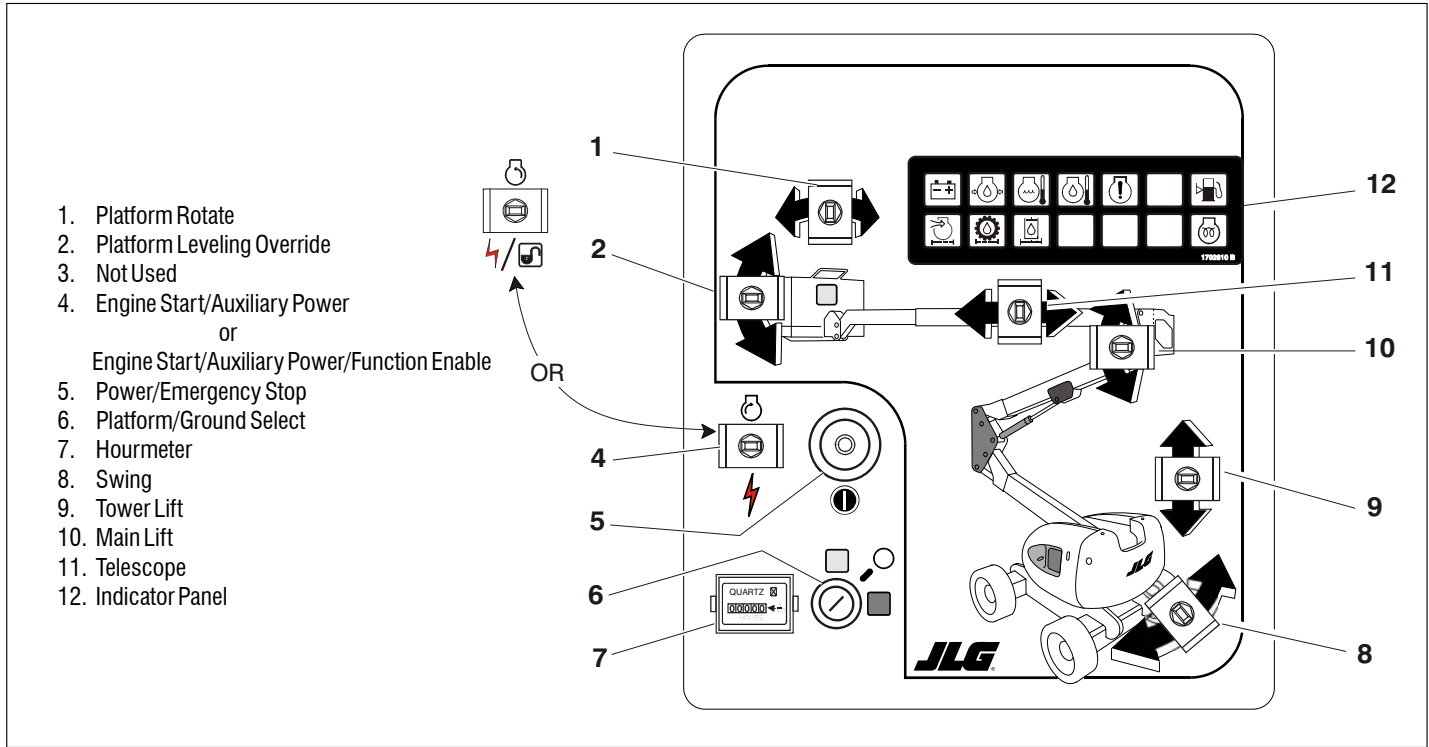

Figure 3-1. Ground Control Station - A Models

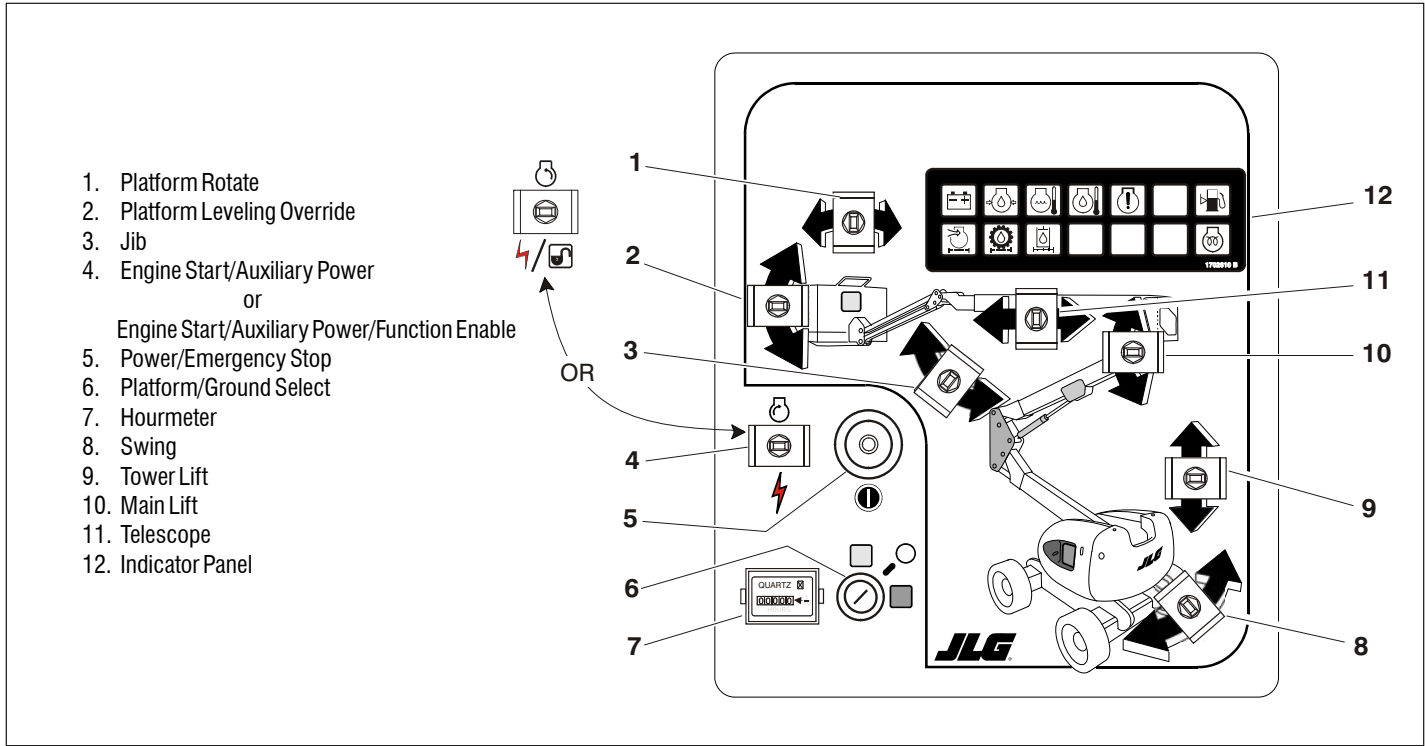

Figure 3-1. Ground Control Station - AJ Models

SECTION 3 - MACHINE CONTROLS AND INDICATORS

3. Articulating Jib Boom (If Equipped)

This switch provides raising and lowering of the jib.

4. Engine Start/Auxiliary Power Switch

or

Engine Start/ Auxiliary Power Switch /Function Enable.



To start the engine, the switch must be held "UP" until the engine starts.



To use auxiliary power, the switch must be held "DOWN" for duration of auxiliary pump use. Aux power can only be used if the engine is not running.



If equipped, the enable switch must be held "DOWN" to enable all boom controls when the engine is running.

NOTE: Auxiliary power only works if there is no oil pressure, and is disabled if engine is running.

5. Power/Emergency Stop

A two-position red mushroom shaped switch furnishes power to Platform/Ground Select switch when pulled out (on). When pushed in (off), power is shut off to the Platform/Ground Select switch.

6. Platform/Ground Select

A three position, key operated switch supplies power to the platform control console when positioned to Platform. With the switch key held in the Ground position, power is shut off to platform and only ground controls are operable.

NOTE: When machine is shut down the Platform/Ground Select switch and Emergency Stop must be positioned to OFF.

NOTE: With PLATFORM/GROUND SELECT switch in the center position, power is shut off to controls at both operating stations.

7. Hourmeter

The hourmeter registers up to 9,999.9 hours and cannot be reset.

8. Swing Control

The Swing control switch provides 360 degrees non-continuous turntable rotation when positioned to the right or left.

9. Tower Lift

Provides for raising and lowering of the Lower and Mid Booms.

10. Main Boom Lift

Provides for raising and lowering of the Main Boom.

11. Telescope

Provides for extension and retraction of the Main Boom.

Ground Control Indicator Panel

1. Battery Charging Indicator

Indicates a problem in the battery or charging circuit, and service is required.

2. Engine Oil Pressure Indicator

Indicates that engine oil pressure is below normal and service is required.

3. Engine Coolant Temperature Indicator (Liquid Cooled Engines)

Indicates that engine coolant temperature is abnormally high and service is required.

4. Engine Oil Temperature Indicator (Deutz)

Indicates that the temperature of the engine oil, which also serves as engine coolant, is abnormally high and service is required.

SECTION 3 - MACHINE CONTROLS AND INDICATORS

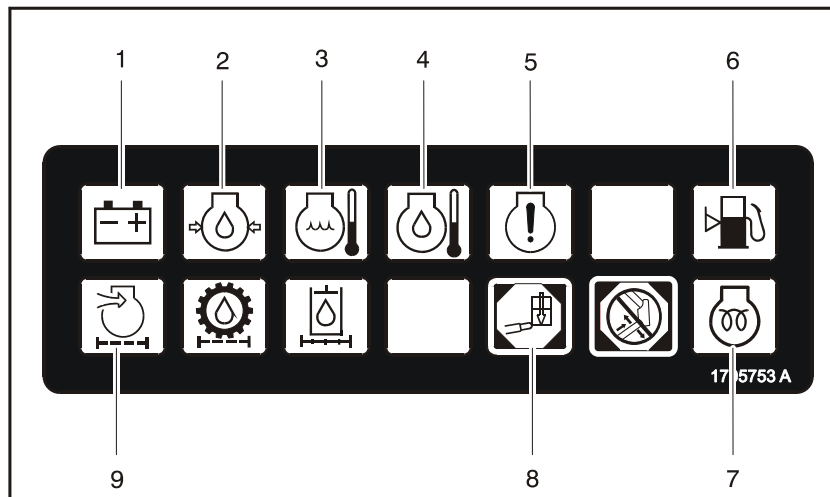

Prior to S/N's 0300099085 & 1300002506

- | | |
|----------------------------|------------------------------|
| 1. Battery Charging | 6. Low Fuel |
| 2. Low Engine Oil Pressure | 7. Glow Plug Wait |
| 3. Engine Coolant Temp. | 8. Overload |
| 4. Engine Oil Temp. | 9. Engine Air Filter By-Pass |
| 5. Engine Malfunction | |

Figure 3-2. Ground Control Indicator Panel - Sheet 1 of 2

SECTION 3 - MACHINE CONTROLS AND INDICATORS

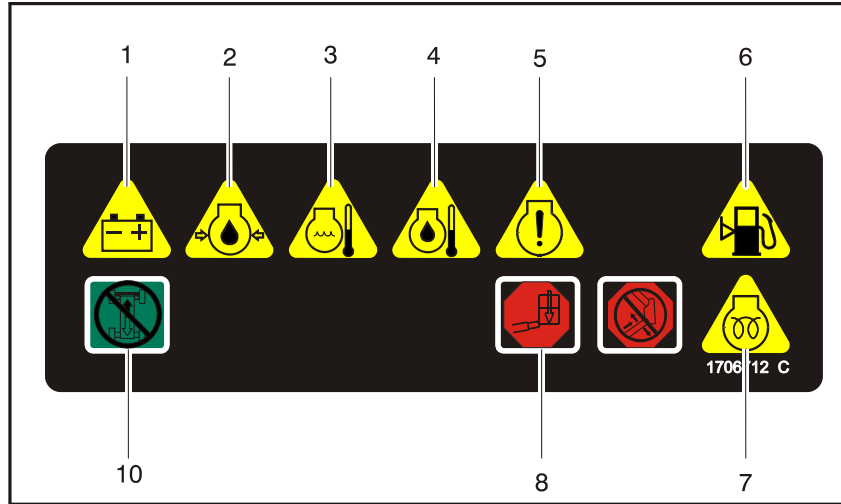

S/N's 0300099085 & 1300002506 to Present

- | | |
|----------------------------|-----------------------------|
| 1. Battery Charging | 6. Low Fuel |
| 2. Low Engine Oil Pressure | 7. Glow Plug Wait |
| 3. Engine Coolant Temp. | 8. Overload |
| 4. Engine Oil Temp. | 9. Not Used |
| 5. Engine Malfunction | 10. Drive and Steer Disable |

Figure 3-3. Ground Control Indicator Panel - Sheet 2 of 2

SECTION 3 - MACHINE CONTROLS AND INDICATORS

5. Engine Malfunction Indicator

The light indicates that the JLG Control System has detected a malfunction and a Diagnostic Trouble Code has been set in the system memory. Refer to the Service Manual for instructions concerning the trouble codes and trouble code retrieval.

The malfunction indicator light will illuminate for 2-3 seconds when the key is positioned to the on position to act as a self test.

6. Low Fuel Level Indicator

Indicates that the fuel level is 1/8 full or less. Illuminates when there are approximately four gallons of fuel remaining.

7. Glow Plug Wait Indicator

Indicates the glow plugs are on. The glow plugs are automatically turned on with the ignition circuit and remain on for approximately seven seconds. Start the engine only after the light goes out.

8. Overload Indicator. (If Equipped)

Indicates the platform has been overloaded.

9. Engine Air Filter Indicator

Indicates that the air filter is too restrictive and needs to be replaced.

10. Drive and Steer Disable Indicator (If equipped)

Indicates the Drive and Steer Disable function has been activated.

Platform Control Station

1. Drive Speed Switch

(4WD Machines) - The forward position gives maximum drive speed by shifting the drive motors to minimum displacement and giving high engine when drive controller is moved. The back position gives maximum torque for rough terrain and climbing grades by shifting the wheel motors to maximum displacement and giving high engine speed when drive controller is moved. The center position allows the machine to be driven as quietly as possible by leaving the engine at mid speed and the drive motors in maximum displacement.

(2WD Machines) - The forward position selects maximum speed by operating at high engine rpm. The backward position selects mid engine rpm.

WARNING

ONLY USE THE PLATFORM LEVELING OVERRIDE FUNCTION FOR SLIGHT LEVELING OF THE PLATFORM. INCORRECT USE COULD CAUSE THE LOAD/OCCUPANTS TO SHIFT OR FALL. FAILURE TO DO SO COULD RESULT IN DEATH OR SERIOUS INJURY.

2. Platform Leveling Override

A three position switch allows the operator to adjust the automatic self leveling system. This switch is used to adjust the platform level in situations such as ascending/descending a grade.

3. Horn

If pressed, this switch supplies power to the horn.

4. Power/Emergency Stop

An on-off Power/Emergency Stop switch and a separate Engine Start/Auxiliary Power toggle switch on the platform console supply electrical power to the starter solenoid, when the ignition switch is placed in the ON position and the ENGINE START switch is push forward.

SECTION 3 - MACHINE CONTROLS AND INDICATORS

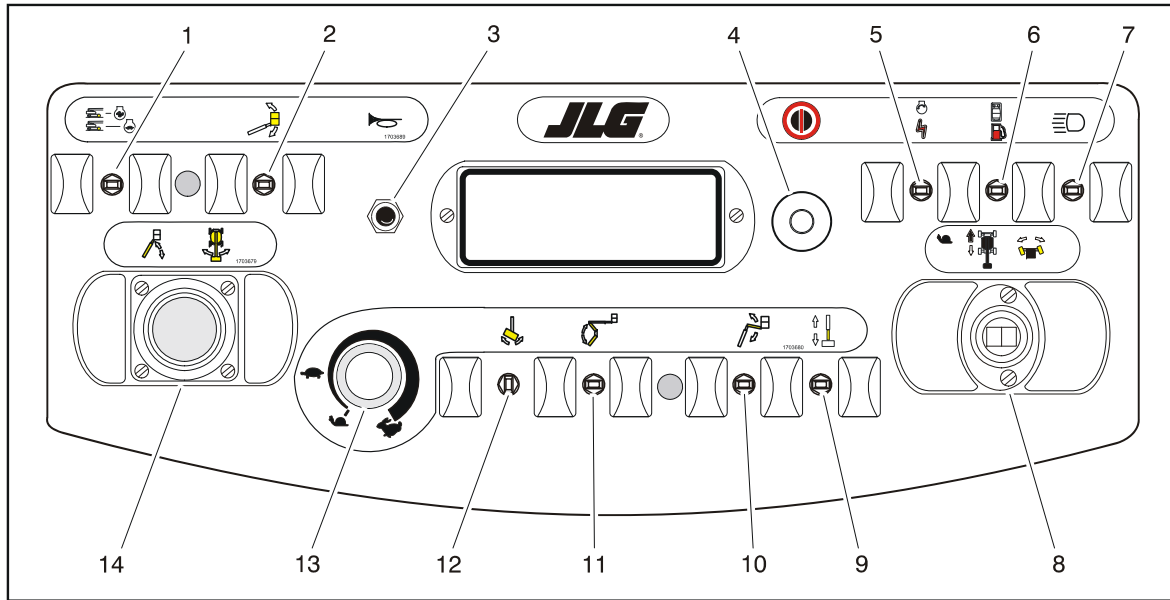

- | | | | |
|-------------------------------|----------------|---------------------|---------------------|
| 1. Drive Speed | 5. Aux. Power | 9. Telescope | 13. Function Speed |
| 2. Platform Leveling Override | 6. Fuel Select | 10. Jib | 14. Main Lift/Swing |
| 3. Horn | 7. Lights | 11. Tower Lift | |
| 4. Power/Emergency Stop | 8. Drive/Steer | 12. Platform Rotate | |

Figure 3-4. Platform Control Console

SECTION 3 - MACHINE CONTROLS AND INDICATORS

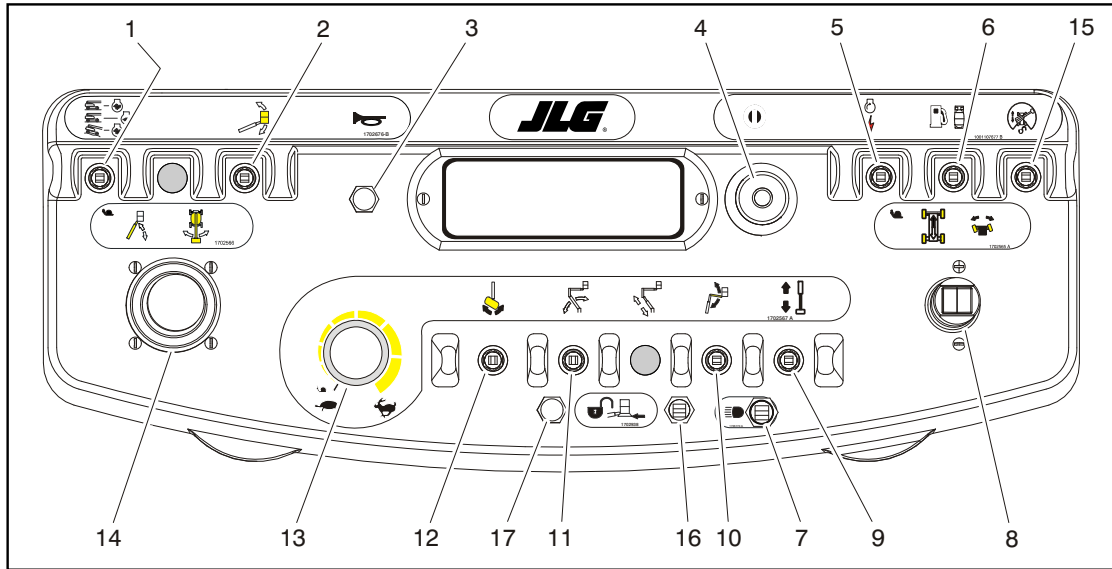

- | | | | |
|-------------------------------|----------------|---------------------|--------------------------------|
| 1. Drive Speed | 6. Fuel Select | 10. Jib | 14. Main Lift/Swing |
| 2. Platform Leveling Override | 7. Lights | 11. Tower Lift | 15. Drive Orientation Override |
| 3. Horn | 8. Drive/Steer | 12. Platform Rotate | 16. Soft Touch Override |
| 4. Power/Emergency Stop | 9. Telescope | 13. Function Speed | 17. Soft Touch Indicator |
| 5. Aux. Power | | | |

Figure 3-5. Platform Control Console - w/Drive Orientation

SECTION 3 - MACHINE CONTROLS AND INDICATORS

WARNING

TO AVOID SERIOUS INJURY, DO NOT OPERATE MACHINE IF ANY CONTROL LEVERS OR TOGGLE SWITCHES CONTROLLING PLATFORM MOVEMENT DO NOT RETURN TO THE OFF OR NEUTRAL POSITION WHEN RELEASED.

5. Auxiliary Power

The Auxiliary Power control switch energizes the electrically operated hydraulic pump. (Switch must be held ON for duration of auxiliary pump use.)

The auxiliary pump functions to provide sufficient oil flow to operate the basic machine functions should the main pump or engine fail. The auxiliary pump will operate tower boom lift, tower telescope, main boom lift, main telescope and swing.

6. Fuel Select (Dual Fuel Engine Only) (If Equipped)

Moving the switch to the appropriate position selects gasoline or liquid propane fuel.

7. Lights (If Equipped)

This switch operates control console panel lights and head lights if the machine is so equipped.

8. Drive/Steer

The DRIVE joystick provides for driving either forward or backward. The controller is 'ramped' to allow variable drive speed.

Steering is controlled by a thumb operated switch on top of the joystick.

9. Telescope Control

This switch allows extension and retraction of the main boom.

10. Articulating Jib Boom (if equipped)

This switch controls the raising or lowering of the jib.

11. Tower or Lower Boom Lift

Provides for raising and lowering of the lower and mid booms when positioned up or down.

12. Platform Rotate

This switch controls the rotation of the basket (left or right).

SECTION 3 - MACHINE CONTROLS AND INDICATORS

13. Function Speed Control

Controls the speed of Boom and Swing Functions. Rotate CCW for slower speed and CW for faster speed. To adjust to creep, turn knob fully CCW until it clicks.

14. Main Lift/Swing

The dual axis joystick is provided for main lift and swing. Push forward to lift up, pull backward to lower. Move right to swing right, move left to swing left. Proportional control of these functions can be attained by using the Function Speed control.

NOTE: *Main lift and swing functions may be selected at the same time. Maximum speed is reduced when both functions are selected.*

15. Drive Orientation Override

When the boom is swung over the rear tires or further in either direction, the Drive Orientation indicator will illuminate when the drive function is selected. Push and release the switch, and within 3 seconds move the Drive/Steer control to activate drive or steer. Before driving, locate the black/white orientation arrows on both the chassis and the platform controls and match the control direction arrow to the intended chassis direction.

16. Soft Touch Override Switch (If equipped)

This switch enables the functions that were cut out by the Soft Touch system to operate again at creep speed, allowing the operator to move the platform away from the obstacle that caused the shutdown situation.

17. Soft Touch Indicator (If Equipped)

Indicates the Soft Touch bumper is against an object. All controls are cut out until the override button is pushed, at which time controls are active in the Creep Mode.

SECTION 3 - MACHINE CONTROLS AND INDICATORS

Platform Control Indicator Panel

NOTE: The platform control indicator panel (S/N 0300065315 to Present) uses different shaped symbols to alert the operator to different types of operational situations that could arise. The meaning of those symbols are explained below.



Indicates a potentially hazardous situation, which if not corrected, could result in serious injury or death. This indicator will be red.



Indicates an abnormal operating condition, which if not corrected, may result in machine interruption or damage. This indicator will be yellow.



Indicates important information regarding the operating condition, i.e. procedures essential for safe operation. This indicator will be green with the exception of the capacity indicator which will be green or yellow depending upon platform position.

1. AC Generator (Green)

Indicates the generator is in operation.

2. Overload Indicator. (If equipped)

Indicates the platform has been overloaded.

3. Tilt Alarm Warning Light and Alarm

This orange illuminator indicates that the chassis is on a slope. An alarm will also sound when the chassis is on a slope and the boom is above horizontal. If lit when boom is raised or extended, retract and lower to below horizontal then reposition machine so that it is level before continuing operation. If the boom is above horizontal and the machine is on a slope, the tilt alarm warning light will illuminate and an alarm will sound and CREEP is automatically activated.

⚠ WARNING

IF TILT WARNING LIGHT IS ILLUMINATED WHEN BOOM IS RAISED OR EXTENDED, RETRACT AND LOWER TO BELOW HORIZONTAL THEN REPOSITION MACHINE SO THAT IT IS LEVEL BEFORE EXTENDING BOOM OR RAISING BOOM ABOVE HORIZONTAL.

4. Glow Plug Indicator

Indicates the glow plugs are operating. After turning on ignition, wait until light goes out before cranking engine.

5. Footswitch/Enable Indicator

To operate any function, the footswitch must be depressed and the function selected within seven seconds. The enable indicator shows that the controls are enabled. If a function is not selected within seven seconds, or if a seven second lapse between ending one function and beginning the next function, the enable light will go out and the footswitch must be released and depressed again to enable the controls.

NOTE: *For engine starting, the footswitch must be in the released (up) position.*

WARNING

TO AVOID SERIOUS INJURY, DO NOT REMOVE, MODIFY OR DISABLE THE FOOTSWITCH BY BLOCKING OR ANY OTHER MEANS.

WARNING

FOOTSWITCH MUST BE ADJUSTED IF FUNCTIONS ACTIVATE WHEN SWITCH ONLY OPERATES WITHIN LAST 1/4" OF TRAVEL, TOP OR BOTTOM.

SECTION 3 - MACHINE CONTROLS AND INDICATORS

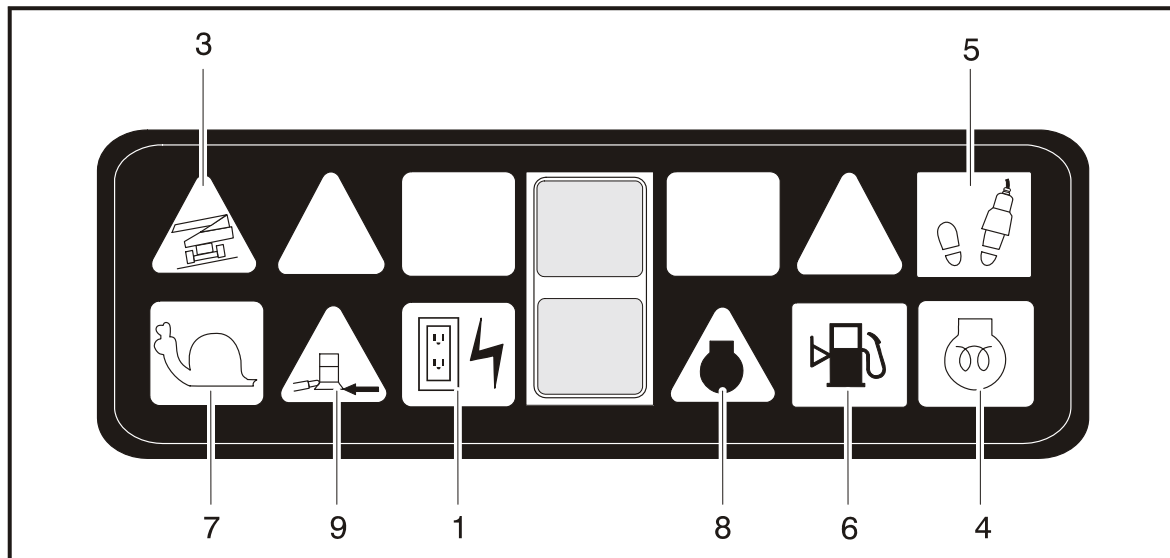

Prior to S/N 0300065315

- | | | |
|-----------------------|---------------|-----------------------|
| 1. AC Generator | 4. Glow Plug | 7. Creep Speed |
| 2. Overload | 5. Enable | 8. System Malfunction |
| 3. Tilt Alarm Warning | 6. Fuel Level | 9. Soft Touch |

Figure 3-6. Platform Control Indicator Panel - Sheet 1 of 2

SECTION 3 - MACHINE CONTROLS AND INDICATORS

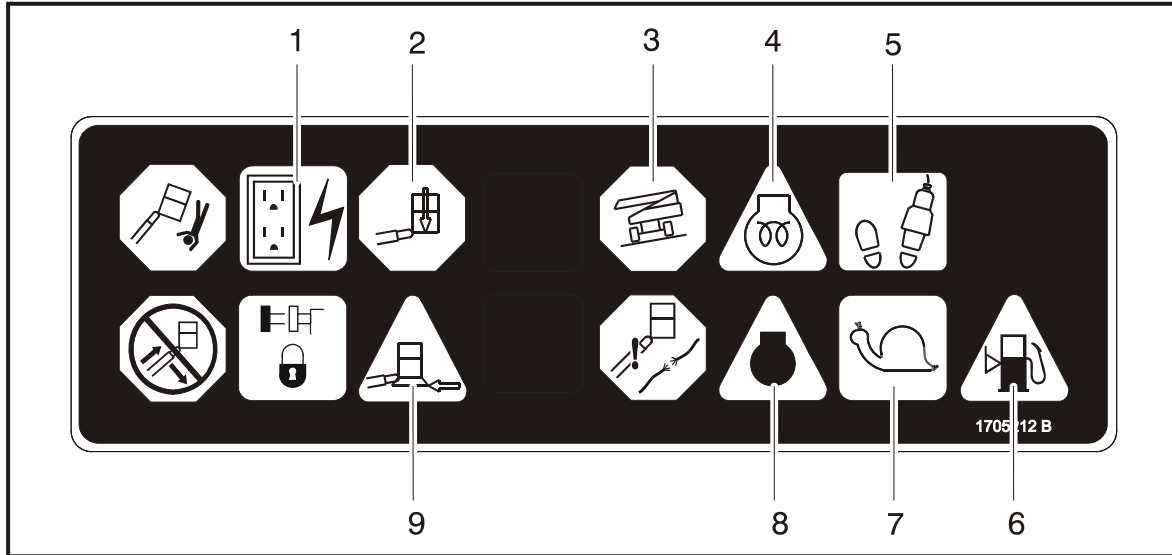

S/N 0300065315 & 1300000001 to Present

- | | | |
|-----------------------|---------------|-----------------------|
| 1. AC Generator | 4. Glow Plug | 7. Creep Speed |
| 2. Overload | 5. Enable | 8. System Malfunction |
| 3. Tilt Alarm Warning | 6. Fuel Level | 9. Soft Touch |

Figure 3-7. Platform Control Indicator Panel - Sheet 2 of 2

SECTION 3 - MACHINE CONTROLS AND INDICATORS

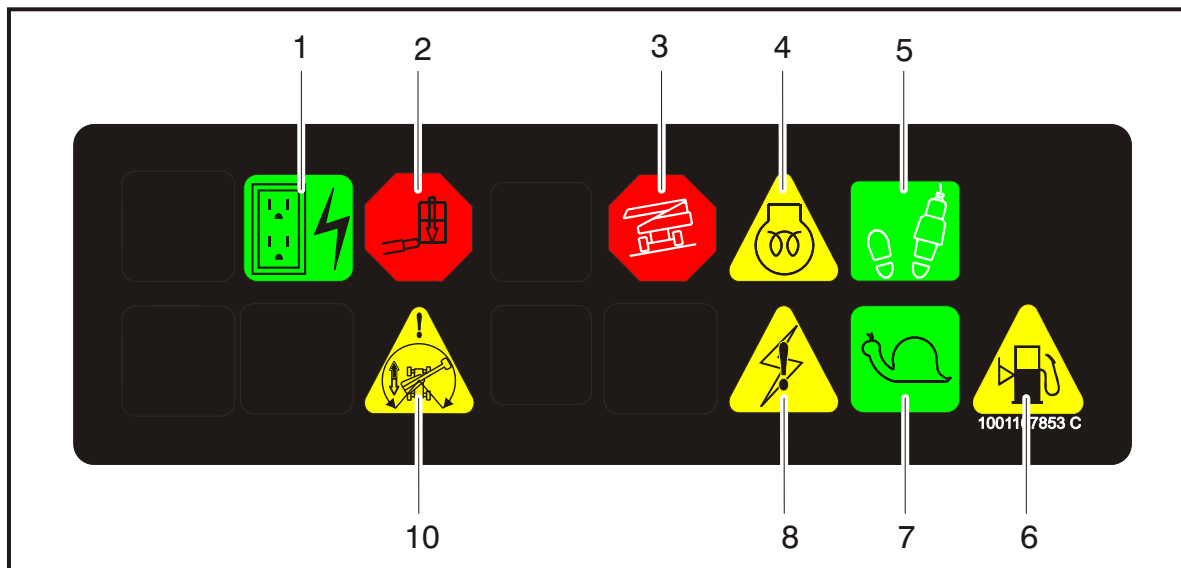

- | | | |
|-----------------------|----------------|-----------------------|
| 1. AC Generator | 5. Enable | 8. System Malfunction |
| 2. Overload | 6. Fuel Level | 9. Not Used |
| 3. Tilt Alarm Warning | 7. Creep Speed | 10. Drive Orientation |
| 4. Glow Plug | | |

Figure 3-8. Platform Control Indicator Panel - w/Drive Orientation

SECTION 3 - MACHINE CONTROLS AND INDICATORS

6. Low Fuel Indicator (Yellow)

Indicates the fuel tank is 1/8 full or less. When the light first illuminates, there are approximately four usable gallons of fuel remaining.

7. Creep Speed Indicator

Illuminates when the Function Speed Control is turned to the creep position.

8. System Malfunction Indicator

The light indicates that the JLG Control System has detected a malfunction and a Diagnostic Trouble Code has been set in the system memory. Refer to the Service Manual for instructions concerning the trouble codes and trouble code retrieval.

The malfunction indicator light will illuminate for 2-3 seconds when the key is positioned to the on position to act as a self test.

9. Soft Touch Indicator (If Equipped)

Illuminates when the Soft Touch bumper is against an object. All controls are cut out until the override button is pushed, at which time controls are active in the Creep mode.

10. Drive Orientation Indicator

When the boom is swung beyond the rear drive tires or further in either direction, the Drive Orientation indicator will illuminate when the drive function is selected. This is a signal for the operator to activate the Drive Orientation Override Switch and verify the drive control direction is correct.

SECTION 4. MACHINE OPERATION

4.1 DESCRIPTION

This machine is a self-propelled hydraulic lift equipped with a work platform on the end of an elevating, articulating and rotating boom.

The primary operator control station is in the platform. From this control station, the operator can drive and steer the machine in both forward and reverse directions. The operator can raise or lower the boom or swing the boom to the left or right. Standard boom swing is 360 degree non continuous left and right of the stowed position. The machine has a Ground Control Station which will override the Platform Control Station. Ground Controls operate Boom Lift and Swing, and are to be used in an emergency to lower the platform to the ground should the operator in the platform be unable to do so. The Ground Control is also to be used in Pre-Start Inspection.

4.2 OPERATING CHARACTERISTICS AND LIMITATIONS

Capacities

The boom can be raised above horizontal with or without any load in platform, if:

1. Machine is positioned on a smooth, firm and level surface.
2. Load is within manufacturer's rated capacity.
3. All machine systems are functioning properly.
4. Proper tire pressure.
5. Machine is as originally equipped from JLG.

Stability

Machine stability is based on two (2) conditions which are called FORWARD and BACKWARD stability. The machine's position of least FORWARD stability is shown in (See Figure 4-1.), and its position of least BACKWARD stability is shown in (See Figure 4-2.)

WARNING

TO AVOID FORWARD OR BACKWARD TIPPING, DO NOT OVERLOAD MACHINE OR OPERATE THE MACHINE ON AN OUT-OF-LEVEL SURFACE.

4.3 ENGINE OPERATION

***NOTE:** Initial starting should always be performed from the Ground Control station.*

Starting Procedure

CAUTION

IF ENGINE FAILS TO START PROMPTLY, DO NOT CRANK FOR AN EXTENDED TIME. SHOULD ENGINE FAIL TO START AGAIN, ALLOW STARTER TO "COOL OFF" FOR 2-3 MINUTES. IF ENGINE FAILS AFTER SEVERAL ATTEMPTS, REFER TO ENGINE MAINTENANCE MANUAL.

***NOTE:** Diesel engines only: After turning on ignition, operator must wait until glow plug indicator light goes out before cranking engine.*

1. Turn key of SELECT switch to GROUND. Position POWER/EMERGENCY STOP switch to ON, then push the ENGINE START switch until engine starts.

CAUTION

ALLOW ENGINE TO WARM-UP FOR A FEW MINUTES AT LOW SPEED BEFORE APPLYING ANY LOAD.

2. After engine has had sufficient time to warm up, shut engine off.
3. Turn SELECT switch to PLATFORM.
4. From Platform, pull POWER/EMERGENCY STOP switch out, then push the ENGINE START switch until engine starts.

NOTE: *Footswitch must be in released (up) position before starter will operate. If starter operates with footswitch in the depressed position, DO NOT OPERATE MACHINE.*

Shutdown Procedure



IF AN ENGINE MALFUNCTION CAUSES AN UNSCHEDULED SHUTDOWN, DETERMINE THE CAUSE AND CORRECT IT BEFORE RESTARTING THE ENGINE.

1. Remove all load and allow engine to operate at low speed for 3-5 minutes; this allows further reduction of internal engine temperature.
2. Push POWER/EMERGENCY STOP switch in.
3. Turn MASTER switch to Off.

Refer to Engine Manufacturer's manual for detailed information.

SECTION 4 - MACHINE OPERATION

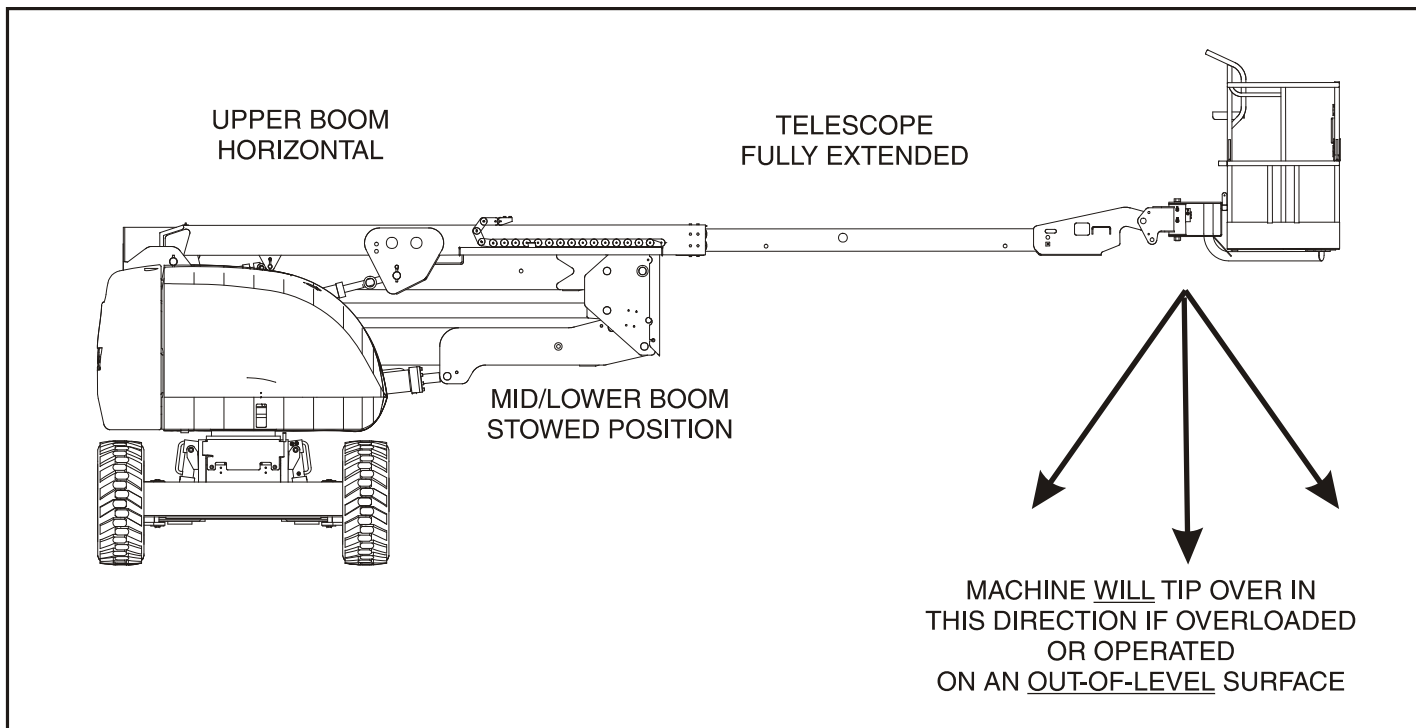

Figure 4-1. Position of Least Forward Stability

4.4 TRAVELING (DRIVING)

⚠ WARNING

DO NOT DRIVE WITH BOOM ABOVE HORIZONTAL EXCEPT ON A SMOOTH, FIRM AND LEVEL SURFACE.

TO AVOID LOSS OF TRAVEL CONTROL OR "TIP OVER", DO NOT DRIVE MACHINE ON GRADES EXCEEDING THOSE SPECIFIED ON THE SERIAL NUMBER TAG OR AS NOTED IN THE OPERATORS MANUAL.

DO NOT DRIVE ON SIDESLOPES WHICH EXCEED 5 DEGREES (ANSI MARKETS) OR 4 DEGREES (CE & AUSTRALIA MARKETS).

USE EXTREME CAUTION WHEN DRIVING IN REVERSE AND AT ALL TIMES WHEN THE PLATFORM IS ELEVATED.

TRAVEL GRADES WITH DRIVE SPEED/TORQUE SELECT SWITCH IN THE FORWARD POSITION. USE CAUTION WHEN DRIVING IN REVERSE AND WHEN DRIVING WITH PLATFORM ELEVATED, ESPECIALLY WHEN DRIVING WITH ANY PART OF MACHINE WITHIN 6 FEET (2 M) OF AN OBSTRUCTION.

BEFORE DRIVING, MAKE SURE BOOM IS POSITIONED OVER REAR DRIVE AXLE. IF BOOM IS OVER FRONT WHEELS, STEER AND DRIVE CONTROLS WILL BE REVERSED.

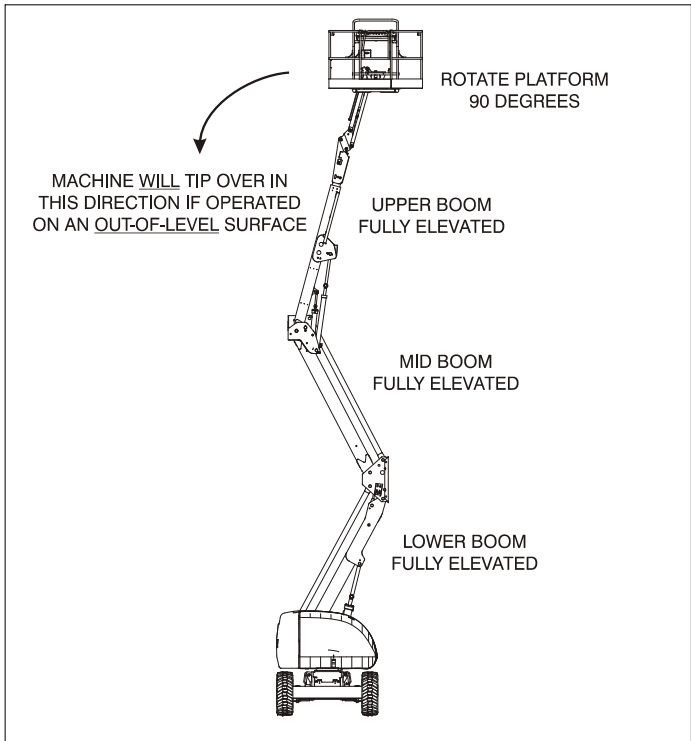

Figure 4-2. Position of Least Backward Stability

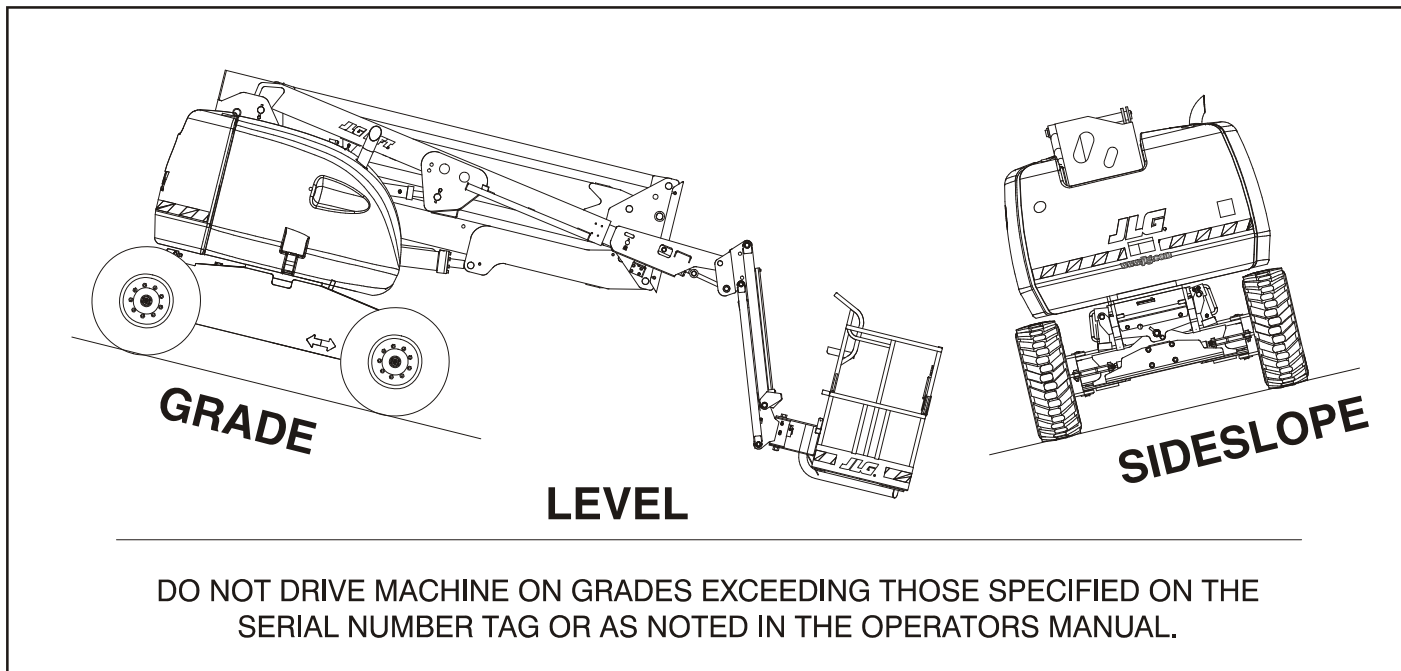

Figure 4-3. Grade and Side Slopes

Traveling Forward and Reverse

1. With the engine running, activate footswitch.
2. Position Drive controller to FORWARD or REVERSE as desired.

This machine is equipped with a Drive Orientation Indicator. The yellow light on the platform control console indicates that the boom is swung beyond the rear drive tires and the machine may Drive/Steer in the opposite direction from the movement of the controls. If the indicator is illuminated, operate the Drive function in the following manner:

1. Match the black and white direction arrows on both platform control panel and the chassis to determine the direction the machine will travel.
2. Push and release the Drive Orientation Override switch. Within 3 seconds, slowly move the Drive control toward the arrow matching the intended direction of machine travel. The indicator light will flash during the 3 second interval until the drive function is selected.

4.5 STEERING

Position thumb switch on Drive/Steer controller to RIGHT for steering right, or to LEFT for steering left.

4.6 PLATFORM

Platform Level Adjustment



ONLY USE THE PLATFORM LEVELING OVERRIDE FUNCTION FOR SLIGHT LEVELING OF THE PLATFORM. INCORRECT USE COULD CAUSE THE LOAD/OCCUPANTS TO SHIFT OR FALL. FAILURE TO DO SO COULD RESULT IN DEATH OR SERIOUS INJURY.

This switch is used to adjust the platform level in situations such as ascending/descending a grade. To Level Up or Down - Position the Platform/Level control switch Up or Down and hold until the platform is level.

Platform Rotation

To rotate the platform to the left or right, use the Platform Rotate control switch to select the direction and hold until desired position is reached.

4.7 BOOM

WARNING

DO NOT SWING OR RAISE BOOM ABOVE HORIZONTAL WHEN MACHINE IS OUT OF LEVEL.

DO NOT DEPEND ON TILT ALARM AS A LEVEL INDICATOR FOR THE CHASSIS.

TO AVOID SERIOUS INJURY, DO NOT OPERATE MACHINE IF ANY CONTROL LEVER OR TOGGLE SWITCH CONTROLLING PLATFORM MOVEMENT DOES NOT RETURN TO THE 'OFF' OR NEUTRAL POSITION WHEN RELEASED.

IF THE PLATFORM DOES NOT STOP WHEN A CONTROL SWITCH OR LEVER IS RELEASED, REMOVE FOOT FROM FOOTSWITCH OR USE EMERGENCY STOP SWITCH TO STOP THE MACHINE.

Swinging the Boom

To swing boom, use SWING control switch to select RIGHT or LEFT direction.

NOTICE

WHEN SWINGING THE BOOM MAKE SURE THERE IS AMPLE ROOM FOR THE BOOM TO CLEAR SURROUNDING WALLS, PARTITIONS AND EQUIPMENT.

Raising and Lowering the Lower and Mid Boom

To raise or lower the Lower Boom, use Lower Boom Lift switch to select UP or DOWN movement.

Raising and Lowering the Main (Upper) Boom

To raise or lower the Upper Boom, use Upper Boom Lift switch to select UP or DOWN movement.

Telescoping the Main Boom

To extend or retract the main boom, use the Main Telescope Control Switch to select IN or OUT movement.

4.8 FUNCTION SPEED CONTROL

This control affects the speed of all boom functions to the right of the control and Platform Rotate. When in the CCW maximum position, Drive is placed in creep speed.

4.9 AUXILIARY PUMP

NOTICE

WHEN OPERATING ON AUXILIARY POWER, DO NOT OPERATE MORE THAN ONE FUNCTION AT THE SAME TIME. SIMULTANEOUS OPERATION CAN OVERLOAD THE AUXILIARY PUMP MOTOR.

The main function of auxiliary power is to lower the platform in the event of primary power failure. Determine the reason for primary power failure and have the problem corrected by a certified JLG service technician. Operate as follows:

1. Position Platform/Ground switch to Platform.
2. Position Power/Emergency Stop switch to the on position.
3. Depress and hold footswitch.
4. Position Auxiliary Power switch to the on position and hold.

5. Operate appropriate control switch or lever for desired function and hold.
6. Release Auxiliary Power switch, selected control switch or lever, and footswitch.
7. Position Power/Emergency Stop switch to the off position.

4.10 OSCILLATING AXLE LOCKOUT TEST (IF EQUIPPED)

NOTICE

LOCKOUT SYSTEM TEST MUST BE PERFORMED QUARTERLY, ANY TIME A SYSTEM COMPONENT IS REPLACED, OR WHEN IMPROPER SYSTEM OPERATION IS SUSPECTED.

Refer to Section 2.3, Oscillating Axle Lockout Test (If Equipped) for procedure.

4.11 SHUT DOWN AND PARK

1. Drive machine to a reasonably well protected area.
2. Be sure the main boom is fully retracted and lowered over rear drive axle.
3. Remove all load and allow engine to operate 3-5 minutes at LOW setting to permit reduction of internal engine temperatures.
4. At Ground Controls, turn KEY SELECT switch to OFF. Push in the Emergency Stop. Remove key.
5. If necessary, cover Platform Control console to protect instruction placards, warning decals and operating controls from hostile environment.

4.12 LIFTING AND TIE DOWN

Lifting

1. Refer to the Serial Number Tag, call JLG Industries, or weigh the individual unit to find out the Gross Vehicle Weight.
2. Place the boom in the stowed position.
3. Remove all loose items from the machine.
4. Properly adjust the rigging to prevent damage to the machine and so the machine remains level.

Tie Down

NOTICE

WHEN TRANSPORTING THE MACHINE, THE BOOM MUST BE FULLY LOWERED INTO THE BOOM REST.

1. Place the boom in the stowed position.
2. Remove all loose items from the machine.
3. Secure the chassis and the platform using straps or chains of adequate strength.

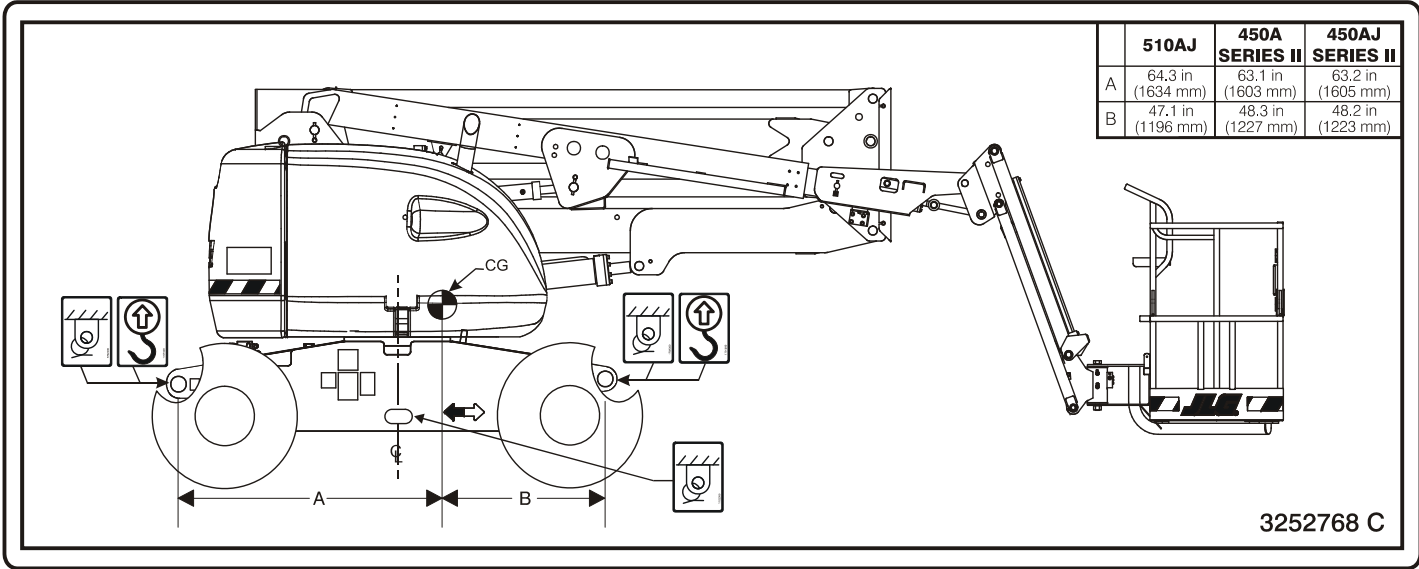

Figure 4-4. Lifting and Tie Down Chart

SECTION 4 - MACHINE OPERATION

4.13 TOWING

⚠ WARNING

RUNAWAY VEHICLE/MACHINE HAZARD. MACHINE HAS NO TOWING BRAKES. TOWING VEHICLE MUST BE ABLE TO CONTROL MACHINE AT ALL TIMES. ON-HIGHWAY TOWING NOT PERMITTED. FAILURE TO FOLLOW INSTRUCTIONS COULD CAUSE SERIOUS INJURY OR DEATH.

MAXIMUM TOWING SPEED 5 M.P.H. (8 K.M.H.) FOR NO LONGER THAN 30-45 MINUTES.

MAXIMUM TOWING GRADE 25%.

Prior to Towing

Prior to towing the machine, complete the following:

⚠ CAUTION

DO NOT TOW MACHINE WITH ENGINE OPERATING OR DRIVE HUBS ENGAGED.

1. Retract, lower and position boom over rear drive wheels in line with direction of travel.

2. Disconnect drive hubs by inverting disconnect cap. (See Figure 4-5.) After towing the machine, complete the following:
3. Reconnect drive hubs by inverting disconnect cap. (See Figure 4-5.)

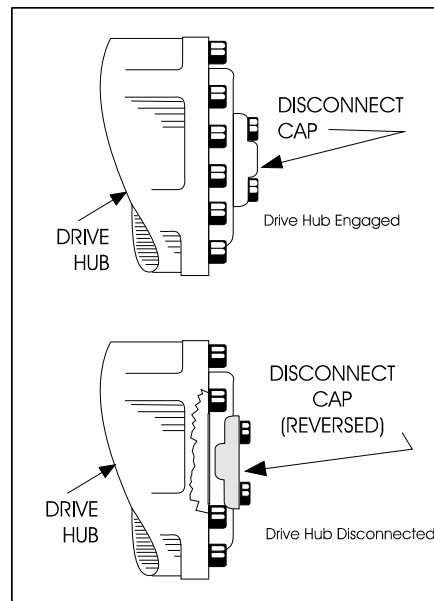

Figure 4-5. Drive Disconnect Hub

4.14 DUAL FUEL SYSTEM (GAS ENGINE ONLY)

The dual fuel system enables the standard gasoline engine to run on either gasoline or LP gas.

⚠ CAUTION

IT IS POSSIBLE TO SWITCH FROM ONE FUEL SOURCE TO THE OTHER WITHOUT ALLOWING THE ENGINE TO STOP. EXTREME CARE MUST BE TAKEN AND THE FOLLOWING INSTRUCTIONS MUST BE FOLLOWED.

Changing From Gasoline to LP Gas

1. Start engine from Ground Control Station.
2. Open hand valve on LP gas supply tank by turning counterclockwise.
3. While engine is operating on GASOLINE under a no-load condition, place FUEL SELECT switch at Platform Control to LP position.

Changing From LP Gas to Gasoline

1. With engine operating on LP under a no-load condition, position FUEL SELECT switch at Platform Control Station to GASOLINE position.
2. Close hand valve on LP gas supply tank by turning clockwise.

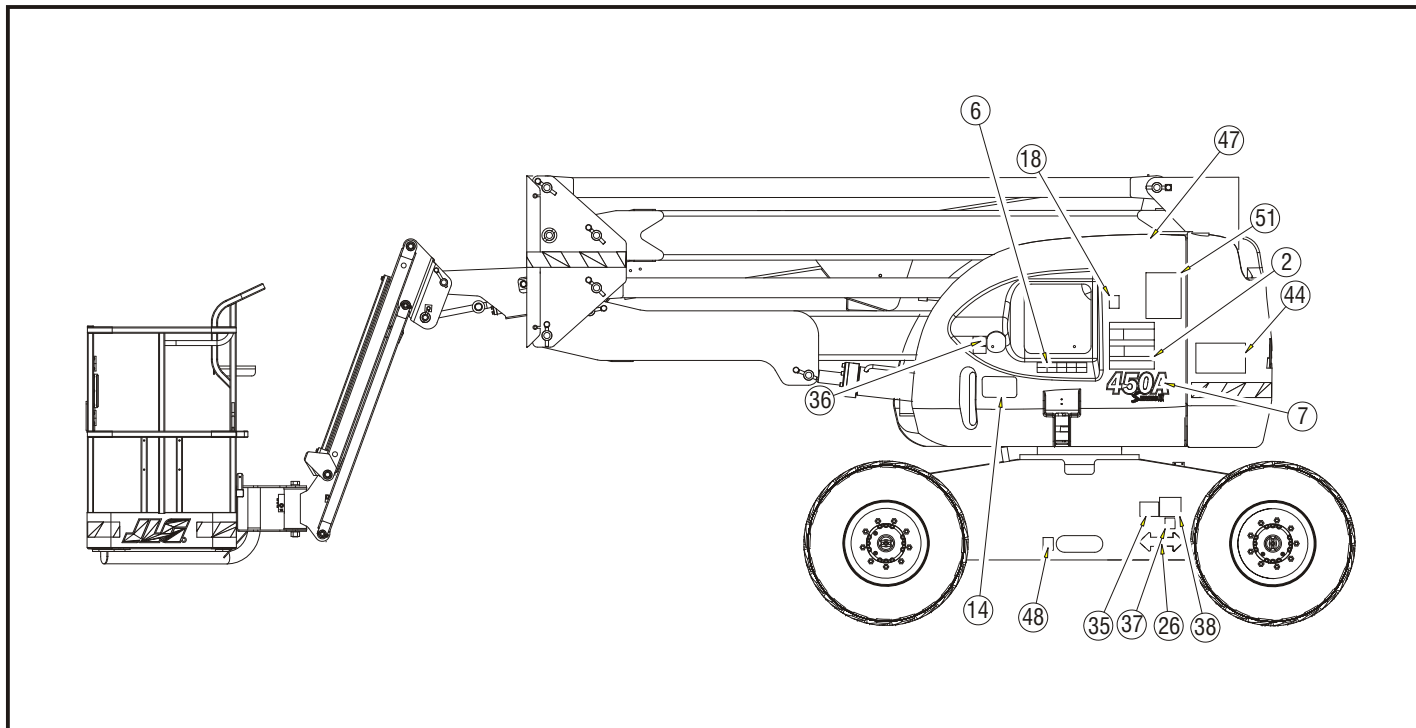

Figure 4-6. Decal Installation - Sheet 1 of 6

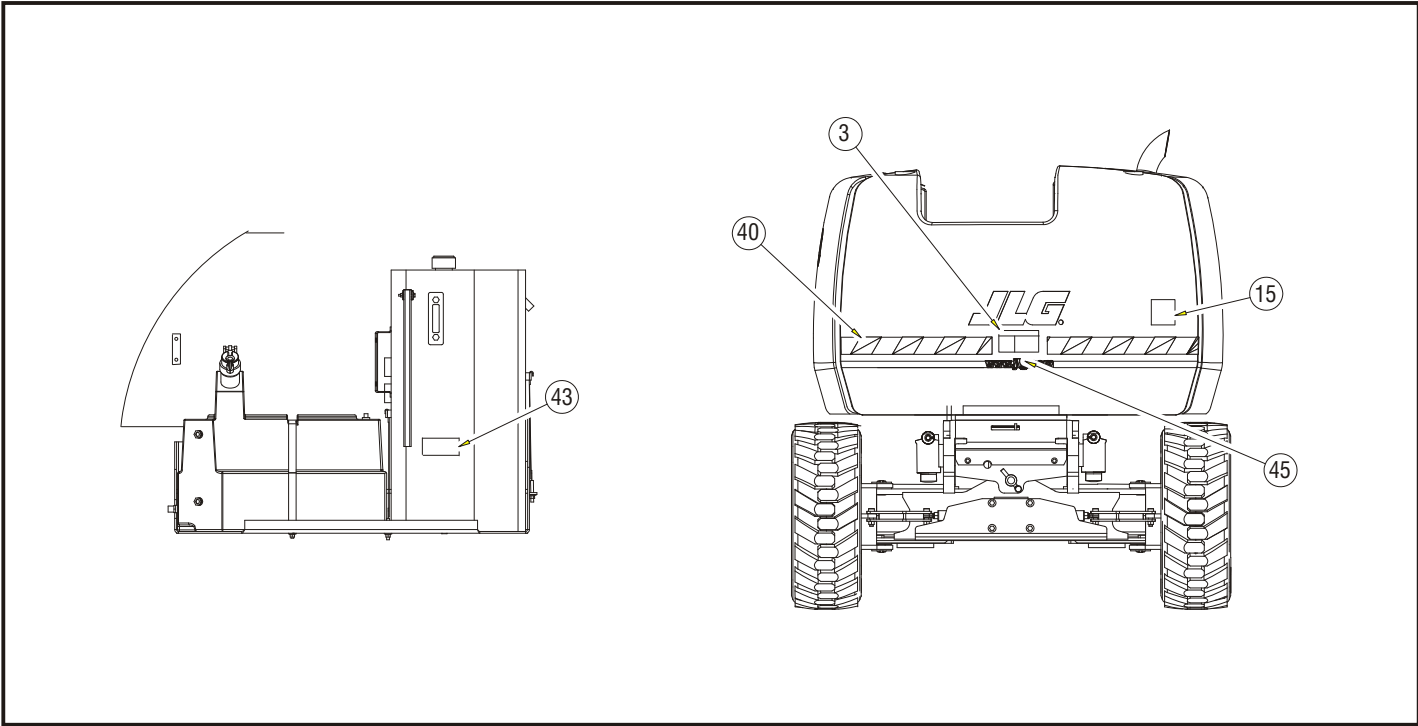

Figure 4-7. Decal Installation - Sheet 2 of 6

SECTION 4 - MACHINE OPERATION

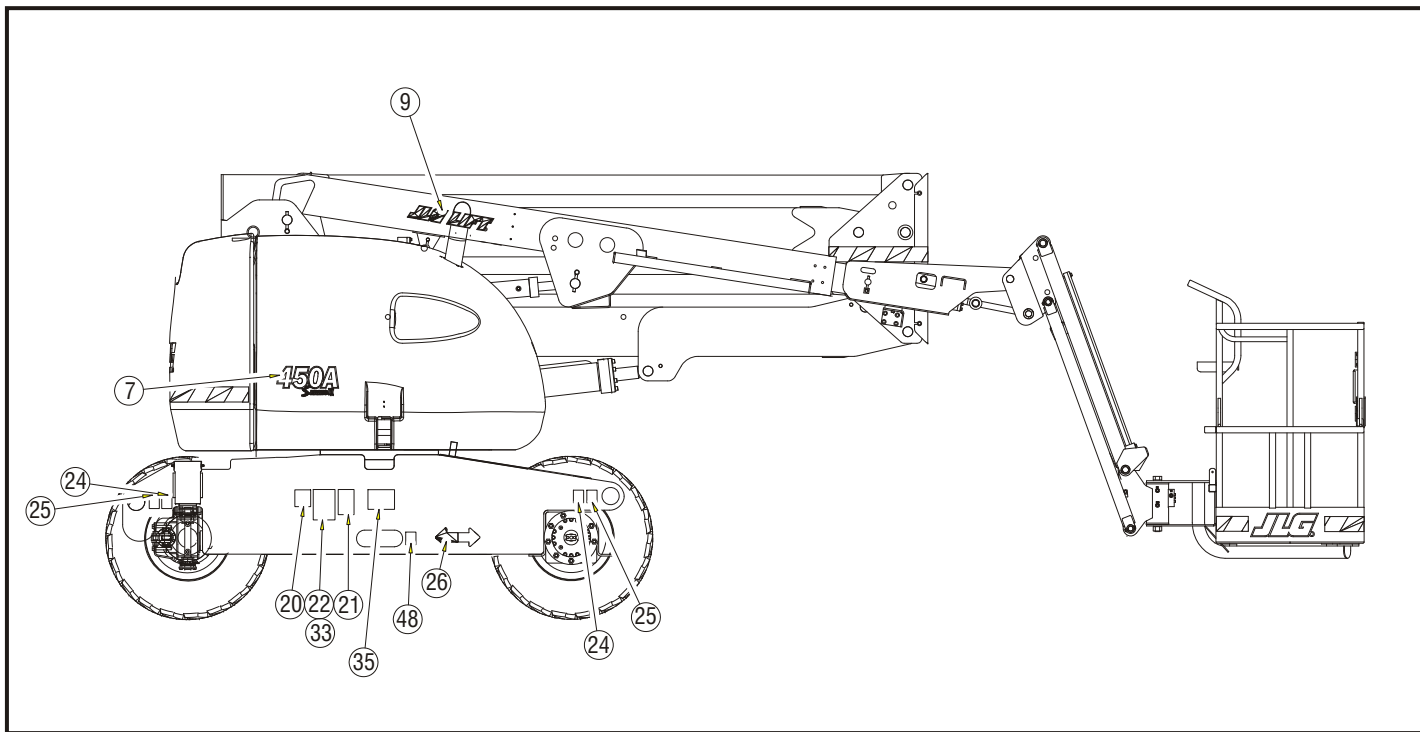

Figure 4-8. Decal Installation - Sheet 3 of 6

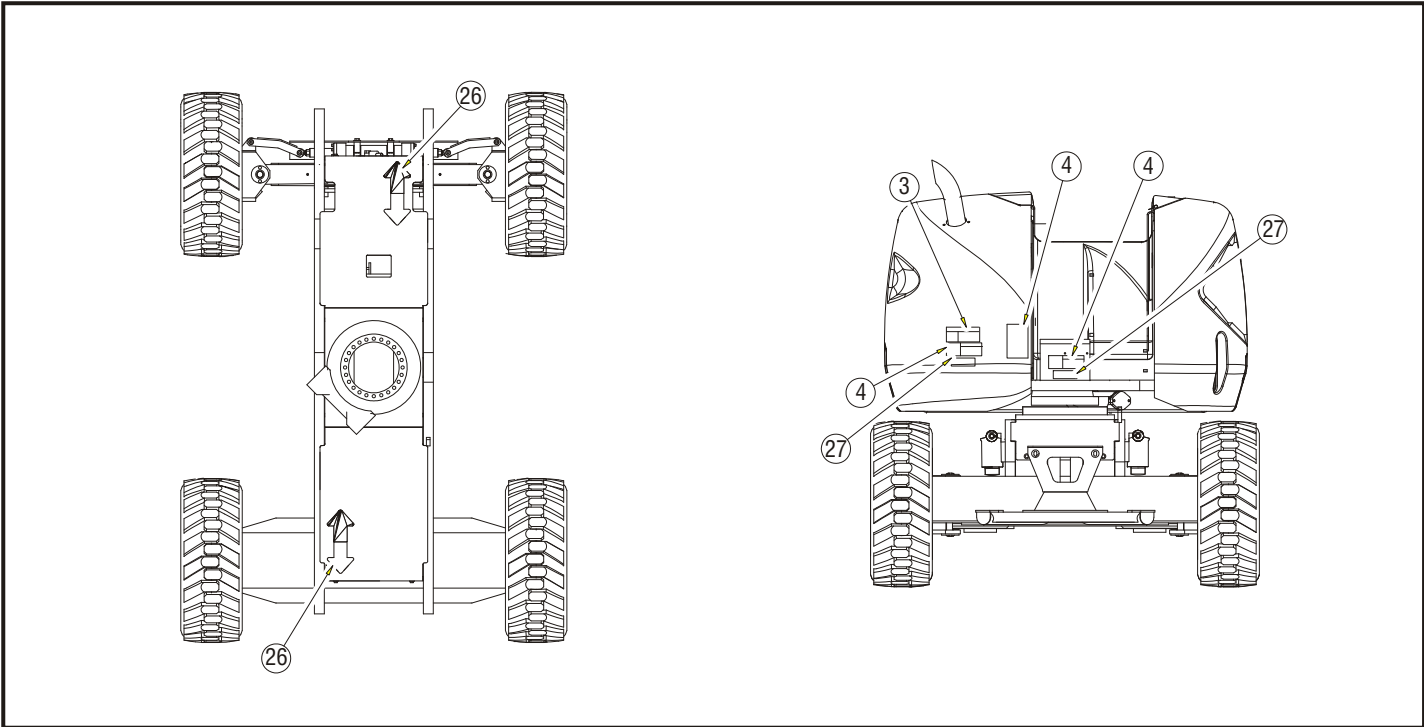

Figure 4-9. Decal Installation - Sheet 4 of 6

SECTION 4 - MACHINE OPERATION

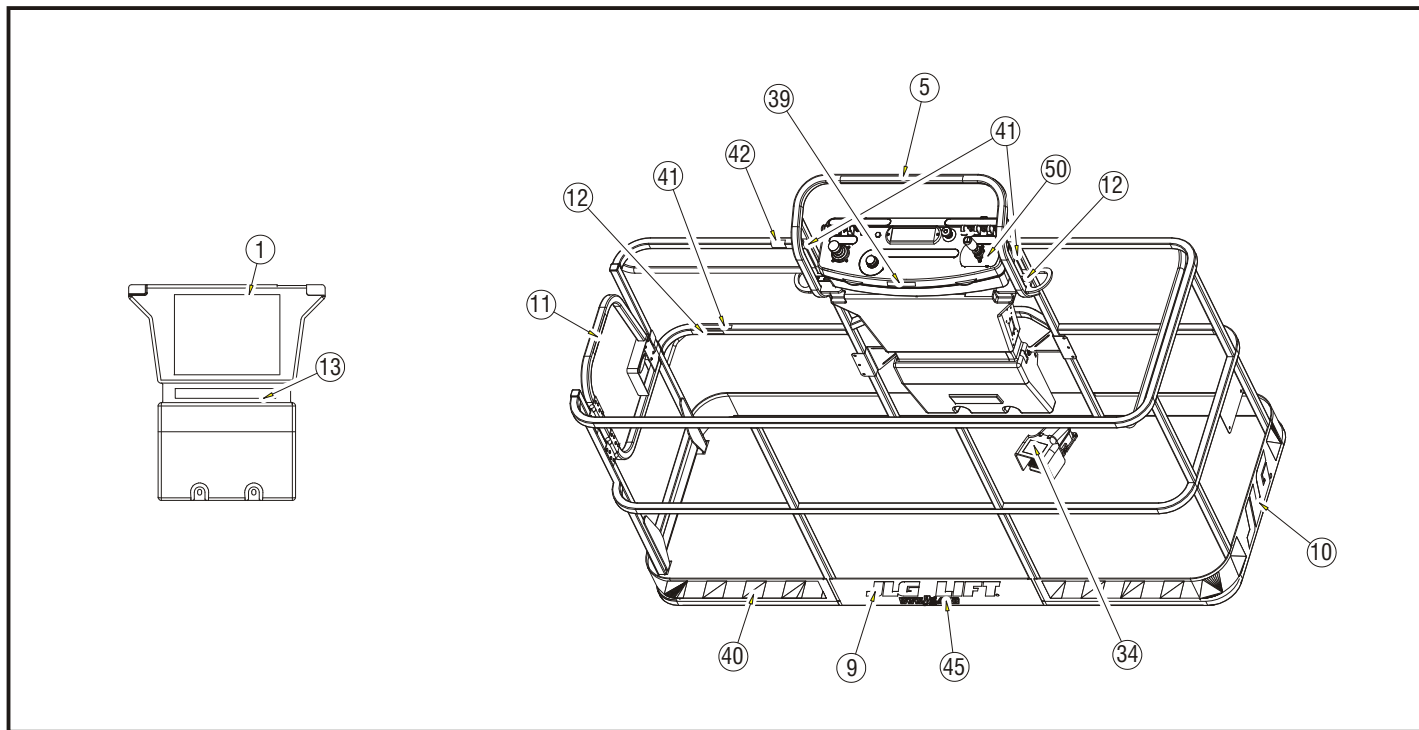

Figure 4-10. Decal Installation - Sheet 5 of 6

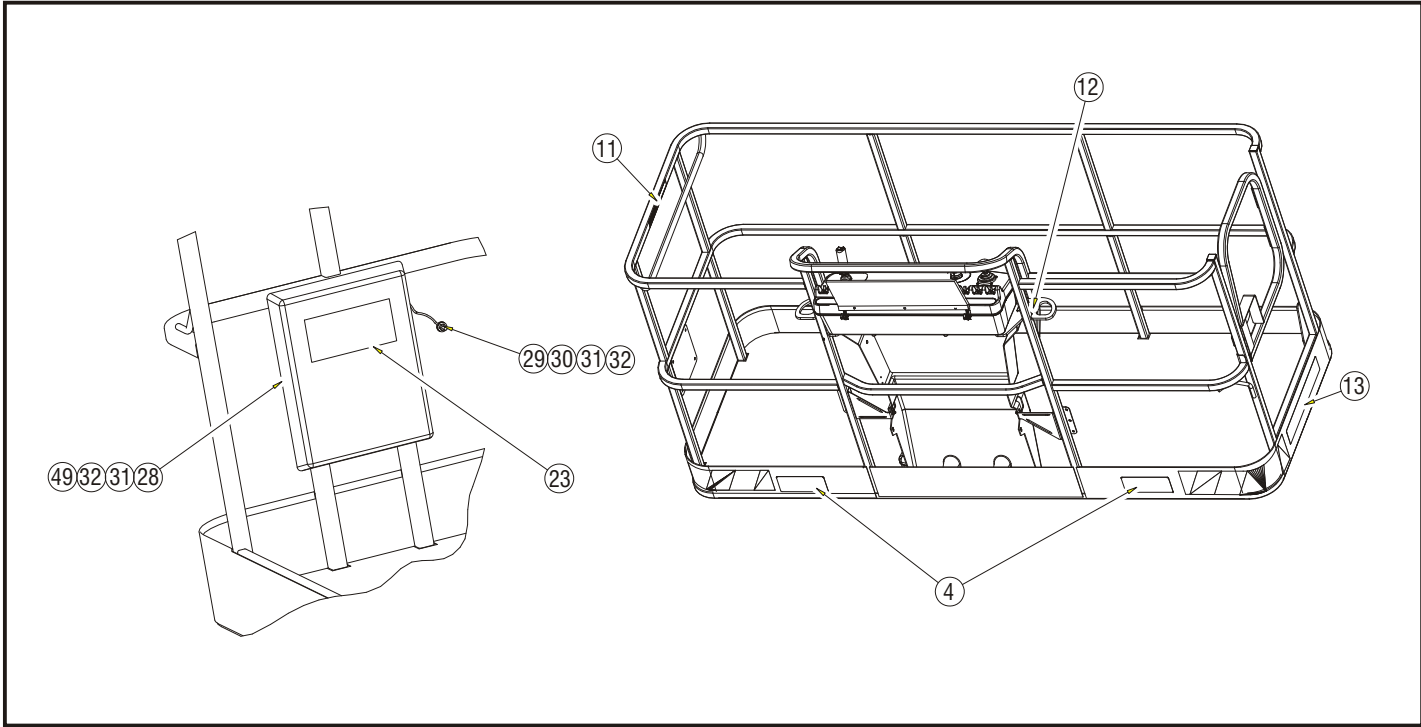

Figure 4-11. Decal Installation - Sheet 6 of 6

SECTION 4 - MACHINE OPERATION

Table 4-1. Decal Legend - Prior to S/N 0300141424

Item #	ANSI 0272573-11	Australian 0272574-6	Japan 0272575-9	Korean 0272576-9	French/ English 0272577-11	Chinese 0272578-9	Portuguese/ Spanish 0272579-10	CE 0273452-4	English/ Spanish 0271189-6
1	1703797	1703992	1703926	1703927	1703924	1703925	1703928	1705821	1703923
2	1703798	1705332	1703932	1703933	1703930	1703931	1703934	1705822	1703929
3	1703805	--	1703938	1703939	1703936	1703937	1703940	--	1703935
4	1703804	1701518	1703950	1703951	1703948	1703949	1703952	1701518	1703947
5	1001108493	--	--	--	1001108493	--	--	--	1001108493
6	1706941	--	--	--	1706941	--	--	--	1706941
7	--	--	--	--	--	--	--	--	--
8	--	--	--	--	--	--	--	--	--
9	--	--	--	--	--	--	--	--	--
10	--	--	--	--	--	--	--	--	--
11	1702868	--	--	--	1704000	--	1704002	--	1704001
12	1704277	1704277	1704277	1704277	1704277	1704277	1704277	1704277	1704277
13	1701645	--	1707059	1707058	1707055	1707060	1707134	--	1707056
14	1707013	--	1707054	1707042	1707047	1707044	1707133	--	1707049
15	--	--	--	--	--	--	--	1705084	--
16	--	--	--	--	--	--	--	--	--

SECTION 4 - MACHINE OPERATION

Table 4-1. Decal Legend - Prior to S/N 0300141424

Item #	ANSI 0272573-11	Australian 0272574-6	Japan 0272575-9	Korean 0272576-9	French/ English 0272577-11	Chinese 0272578-9	Portuguese/ Spanish 0272579-10	CE 0273452-4	English/ Spanish 0271189-6
17	--	--	--	--	--	--	--	--	--
18	1701504	1701504	1701504	1701504	1701504	1701504	1701504	1701504	1701504
19	--	--	--	--	1704006	--	1704008	--	1704007
20	1702631	1702631	1702631	1702631	1702631	1702631	1702631	1702631	1702631
21	--	--	--	--	--	--	--	--	--
22	--	1702958	--	--	--	--	--	--	--
23	1701509	1701509	1701509	1701509	1701509	1701509	1701509	1701509	1701509
24	1702300	1702300	1702300	1702300	1702300	1702300	1702300	1702300	1702300
25	1701500	1701500	1701500	1701500	1701500	1701500	1701500	1701500	1701500
26	1701529	1701529	1701529	1701529	1701529	1701529	1701529	1701529	1701529
27	--	--	--	--	--	--	--	--	--
28	--	--	--	--	--	--	--	--	--
29	--	--	--	--	--	--	--	--	--
30	--	--	--	--	--	--	--	--	--
31	--	--	--	--	--	--	--	--	--
32	--	--	--	--	--	--	--	--	--
33	--	--	--	--	--	--	--	--	--
34	3252347	--	1703980	1703981	1703984	1703982	1703985	1705828	1703983

SECTION 4 - MACHINE OPERATION

Table 4-1. Decal Legend - Prior to S/N 0300141424

Item #	ANSI 0272573-11	Australian 0272574-6	Japan 0272575-9	Korean 0272576-9	French/ English 0272577-11	Chinese 0272578-9	Portuguese/ Spanish 0272579-10	CE 0273452-4	English/ Spanish 0271189-6
35	--	--	--	--	--	--	--	--	--
36	--	--	--	--	--	--	--	--	--
37	--	--	--	--	--	--	--	--	--
38	--	--	--	--	--	--	--	--	--
39	--	--	--	--	1705514	--	--	--	--
40	--	--	--	--	--	--	--	--	--
41	--	--	--	--	--	--	--	--	--
42	--	--	--	--	--	--	--	--	--
43	--	--	--	--	--	--	--	--	--
44	3252768	3252768	3252768	3252768	3252768	3252768	3252768	3252768	3252768
45	1704885	1704885	1704885	1704885	1704885	1704885	1704885	1704885	1704885
46	--	--	--	--	--	--	--	--	--
47	--	--	--	--	--	--	--	--	--
48	--	--	--	--	--	--	--	--	--
49	--	--	--	--	--	--	--	--	--
50	1705351	--	1705426	1705427	1705429	1705430	1705905	--	1705910
51	--	1001112551	--	--	--	--	--	--	--

SECTION 4 - MACHINE OPERATION

Table 4-2. Decal Legend - S/N 0300141424 to Present

Item #	ANSI 0272573-12	Australian 0272574-6	Japan 0272575-10	Korean 0272576-10	French/ 0272577-12	Chinese 0272578-10	Portuguese/ Spanish 0272579-11	CE 0273452-4	English/ Spanish 0271189-7
1	1703797	1703992	1703926	1703927	1703924	1703925	1703928	1705821	1703923
2	1703798	1705332	1703932	1703933	1703930	1703931	1703934	1705822	1703929
3	1703805	--	1703938	1703939	1703936	1703937	1703940	--	1703935
4	1703804	1701518	1703950	1703951	1703948	1703949	1703952	1701518	1703947
5	1001108493	--	--	--	1001108493	--	--	--	1001108493
6	1706941	--	--	--	1706941	--	--	--	1706941
7	--	--	--	--	--	--	--	--	--
8	--	--	--	--	--	--	--	--	--
9	--	--	--	--	--	--	--	--	--
10	--	--	--	--	--	--	--	--	--
11	1702868	--	--	--	1704000	--	1704002	--	1704001
12	1704277	1704277	1704277	1704277	1704277	1704277	1704277	1704277	1704277
13	1001121801	--	1001121808	1001121918	1001121803	1001121810	1001121920	--	1001121805
14	1001121814	--	1001121821	1001121921	1001121816	1001121823	1001121923	--	1001121818
15	--	--	--	--	--	--	--	1705084	--
16	--	--	--	--	--	--	--	--	--

SECTION 4 - MACHINE OPERATION

Table 4-2. Decal Legend - S/N 0300141424 to Present

Item #	ANSI 0272573-12	Australian 0272574-6	Japan 0272575-10	Korean 0272576-10	French/ 0272577-12	Chinese 0272578-10	Portuguese/ Spanish 0272579-11	CE 0273452-4	English/ Spanish 0271189-7
17	--	--	--	--	--	--	--	--	--
18	1701504	1701504	1701504	1701504	1701504	1701504	1701504	1701504	1701504
19	--	--	--	--	1704006	--	1704008	--	1704007
20	1702631	1702631	1702631	1702631	1702631	1702631	1702631	1702631	1702631
21	--	--	--	--	--	--	--	--	--
22	--	1702958	--	--	--	--	--	--	--
23	1701509	1701509	1701509	1701509	1701509	1701509	1701509	1701509	1701509
24	1702300	1702300	1702300	1702300	1702300	1702300	1702300	1702300	1702300
25	1701500	1701500	1701500	1701500	1701500	1701500	1701500	1701500	1701500
26	1701529	1701529	1701529	1701529	1701529	1701529	1701529	1701529	1701529
27	--	--	--	--	--	--	--	--	--
28	--	--	--	--	--	--	--	--	--
29	--	--	--	--	--	--	--	--	--
30	--	--	--	--	--	--	--	--	--
31	--	--	--	--	--	--	--	--	--
32	--	--	--	--	--	--	--	--	--
33	--	--	--	--	--	--	--	--	--
34	3252347	--	1703980	1703981	1703984	1703982	1703985	1705828	1703983

SECTION 4 - MACHINE OPERATION

Table 4-2. Decal Legend - S/N 0300141424 to Present

Item #	ANSI 0272573-12	Australian 0272574-6	Japan 0272575-10	Korean 0272576-10	French/ 0272577-12	Chinese 0272578-10	Portuguese/ Spanish 0272579-11	CE 0273452-4	English/ Spanish 0271189-7
35	--	--	--	--	--	--	--	--	--
36	--	--	--	--	--	--	--	--	--
37	--	--	--	--	--	--	--	--	--
38	--	--	--	--	--	--	--	--	--
39	--	--	--	--	1705514	--	--	--	--
40	--	--	--	--	--	--	--	--	--
41	--	--	--	--	--	--	--	--	--
42	--	--	--	--	--	--	--	--	--
43	--	--	--	--	--	--	--	--	--
44	3252768	3252768	3252768	3252768	3252768	3252768	3252768	3252768	3252768
45	1704885	1704885	1704885	1704885	1704885	1704885	1704885	1704885	1704885
46	--	--	--	--	--	--	--	--	--
47	--	--	--	--	--	--	--	--	--
48	--	--	--	--	--	--	--	--	--
49	--	--	--	--	--	--	--	--	--
50	1705351	--	1705426	1705427	1705429	1705430	1705905	--	1705910
51	--	1001112551	--	--	--	--	--	--	--

SECTION 5. EMERGENCY PROCEDURES

5.1 GENERAL

This section explains the steps to be taken in case of an emergency situation while operating.

Failure to notify the manufacturer of an incident involving a JLG Industries product within 48 hours of such an occurrence may void any warranty consideration on that particular machine.

5.2 INCIDENT NOTIFICATION

JLG Industries, Inc. must be notified immediately of any incident involving a JLG product. Even if no injury or property damage is evident, the factory should be contacted by telephone and provided with all necessary details.

In USA:

JLG Phone: 877-JLG-SAFE (554-7233)
(8am till 4:45pm EST)

Outside USA:

240-420-2661

E-mail:

ProductSafety@JLG.com

NOTICE

FOLLOWING ANY ACCIDENT, THOROUGHLY INSPECT THE MACHINE AND TEST ALL FUNCTIONS FIRST FROM THE GROUND CONTROLS, THEN FROM THE PLATFORM CONTROLS. DO NOT LIFT ABOVE 10 FT. (3 M) UNTIL YOU ARE SURE THAT ALL DAMAGE HAS BEEN REPAIRED, IF REQUIRED, AND THAT ALL CONTROLS ARE OPERATING CORRECTLY.

5.3 EMERGENCY OPERATION

Operator Unable to Control Machine

IF THE PLATFORM OPERATOR IS PINNED, TRAPPED OR UNABLE TO OPERATE OR CONTROL MACHINE:

1. Other personnel should operate the machine from ground controls only as required.
2. Other qualified personnel on the platform may use the platform controls. **DO NOT CONTINUE OPERATION IF CONTROLS DO NOT FUNCTION PROPERLY.**
3. Cranes, forklift trucks or other equipment can be used to remove platform occupants and stabilize motion of the machine.

Platform or Boom Caught Overhead

If the platform or boom becomes jammed or snagged in overhead structures or equipment, rescue platform occupants prior to freeing the machine.

5.4 EMERGENCY TOWING PROCEDURES

Towing this machine is prohibited, unless properly equipped. However, provisions for moving the machine have been incorporated. For specific procedures, refer to Section 4.

SECTION 6. GENERAL SPECIFICATIONS & OPERATOR MAINTENANCE

6.1 INTRODUCTION

This section of the manual provides additional necessary information to the operator for proper operation and maintenance of this machine.

The maintenance portion of this section is intended as information to assist the machine operator to perform daily maintenance tasks only, and does not replace the more thorough Preventive Maintenance and Inspection Schedule included in the Service and Maintenance Manual.

Other Publications Available:

450A/450AJ Service and Maintenance Manual.....	3121180
510AJ Service and Maintenance Manual	3121181
450A/450AJ Illustrated Parts Manual (Prior to S/N 0300124000-USA, S/N 1300006000-Belgium).....	3121243
450A/450AJ Illustrated Parts Manual (S/N 0300124000-USA, S/N 1300006000-Belgium to Present)	3121244
510AJ Illustrated Parts Manual	3121182

6.2 OPERATING SPECIFICATIONS AND PERFORMANCE DATA

Table 6-1. Operating Specifications - 450A/450AJ - Prior to S/N 0300141424

Unrestricted Rated Capacity	500 lb. (230 kg)
Maximum Capacity	500 lb. (230 kg)
Maximum Travel Grade (Gradeability) with Boom retracted and approximately horizontal. Tower Boom fully lowered (if equipped). 2WD 4WD	30% 45%
Maximum Travel Grade (Sideslope) with Boom retracted and approximately horizontal. Tower Boom fully lowered (if equipped) - ANSI Markets.	5°
Maximum Travel Grade (Sideslope) with Boom retracted and approximately horizontal. Tower Boom fully lowered (if equipped) - CE & Australia Markets.	4°

SECTION 6 - GENERAL SPECIFICATIONS & OPERATOR MAINTENANCE

Table 6-1. Operating Specifications - 450A/450AJ - Prior to S/N 0300141424

Maximum Drive Speed:	4.5 mph (2.0 m/s)
Maximum Hyd. Operating Pressure	4500 psi (310 Bar)
Electrical System Voltage	12 volts
Gross Machine Weight (450A) (450AJ)	14,500 lb. (6577 kg) 16,500 lb. (7484 kg)

Table 6-2. Operating Specifications - 450A/450AJ - S/N 0300141424 to Present

Unrestricted Rated Capacity ANSI CE & Australia	500 lb. (227 kg) 500 lb. (230 kg)
Maximum Capacity ANSI CE & Australia	500 lb. (227 kg) 500 lb. (230 kg)
Maximum Travel Grade (Gradeability) with Boom retracted and approxi- mately horizontal. Tower Boom fully lowered (if equipped). 2WD 4WD	30% 45%

Table 6-2. Operating Specifications - 450A/450AJ - S/N 0300141424 to Present

Maximum Travel Grade (Sideslope) with Boom retracted and approxi- mately horizontal. Tower Boom fully lowered (if equipped) - ANSI Mar- kets.	5°
Maximum Travel Grade (Sideslope) with Boom retracted and approxi- mately horizontal. Tower Boom fully lowered (if equipped) - CE & Austr- alia Markets.	4°
Maximum Drive Speed:	4.5 mph (2.0 m/s)
Maximum Hyd. Operating Pressure	4500 psi (310 Bar)
Electrical System Voltage	12 volts
Gross Machine Weight (450A) (450AJ)	14,500 lb. (6577 kg) 16,500 lb. (7484 kg)

SECTION 6 - GENERAL SPECIFICATIONS & OPERATOR MAINTENANCE

Table 6-3. Operating Specifications - 510AJ

Unrestricted Rated Capacity	500 lb. (230 kg)
Maximum Capacity	500 lb. (230 kg)
Maximum Travel Grade (Gradeability) with Boom retracted and approximately horizontal. Tower Boom fully lowered (if equipped).	45%
Maximum Travel Grade (Sideslope) with Boom retracted and approximately horizontal. Tower Boom fully lowered (if equipped) - ANSI Markets.	5°
Maximum Travel Grade (Sideslope) with Boom retracted and approximately horizontal. Tower Boom fully lowered (if equipped) - CE & Australia Markets.	4°
Maximum Drive Speed:	4.5 mph (2.0 m/s)
Maximum Hyd. Operating Pressure	4500 psi (310 Bar)
Electrical System Voltage	12 volts
Gross Machine Weight	16,104 lb. (7305 kg)

Reach Specifications

Table 6-4. Reach Specifications - 450

Max. Platform Height	45ft. (13.72 M)
Max. Horizontal Reach	24.5ft. (7.47 M)
Up & Over Height	25 ft. 2 in. (7.7 M)
Main Boom Up Angle	75°
Main Boom Down Angle	-24°

Table 6-5. Reach Specifications - 510

Max. Platform Height	51.8 ft. (15.81 m)
Platform Rotation	180°
Max. Horizontal Reach	31.1 ft. (9.48 m)
Up & Over Height	24.08 ft. (7.34 m)
Jib Length	4.5 ft. (1.37 m)
Jib Angle	135° (+70°, -65°)

SECTION 6 - GENERAL SPECIFICATIONS & OPERATOR MAINTENANCE

Dimensional Data

Table 6-6. Dimensional Data - 450

Overall Width (12 x 16.5 tire) (33/1550 tire) (14 x 16.1 tire)	6 ft. 6 in. (1.98 m) 6 ft. 10 in. (2.08 m) 6 ft. 11 in. (2.11 m)
Tailswing	0
Stowed Height	7 ft. 4.4 in. (2.25 m)
Stowed Length	21 ft. 4 in. (6.5 m)
Wheel base	78 in. (1.98 m)
Track Width (12 x 16.5 tire) (33/1550 tire) (14 x 16.1 tire)	65.3 in. (1.66 m) 66.3 in. (1.69 m) 66.6 in. (1.69 m)
Ground Clearance	14 in. (0.36 m)

Table 6-7. Dimensional Data - 510

Overall Width	7.4 ft. (2.26 m)
Tailswing	0
Stowed Height	7.4 ft. (2.26 m)
Stowed Length	25.1 ft. (7.68 m)
Wheel base	7.67 ft. (2.34 m)

Table 6-7. Dimensional Data - 510

Track Width (12 x 16.5 tire) (33/1550 tire) (14 x 16.1 tire)	65.3 in. (1.66 m) 66.3 in. (1.69 m) 66.6 in. (1.69 m)
Ground Clearance	1.18 ft. (0.36 m)

Chassis

Table 6-8. Chassis Specifications - 450

Swing	360° non-continuous
Rated Gradeability 2WD 4WD	30% 45%
Max. Tire Load	7900 lb. (3583 kg)
Axle Oscillation	8 in. (0.2 m)
System Voltage	12 Volts
Max. Hydraulic System Operating Pressure	4500 psi (310 bar)
Gross Machine Weight 450A SII 450AJ SII	14,500 lbs. (6577 kg) 16,500 lbs. (7484 kg)

SECTION 6 - GENERAL SPECIFICATIONS & OPERATOR MAINTENANCE

Table 6-9. Chassis Specifications - 510

Swing	357° non-continuous
Gradeability (boom in stowed position)	40%
Max. Tire Load	7900 lb. (3583 kg)
Max. Ground Bearing Pressure	
12x16.5 Tire	48 psi (3.37 kg/cm ²)
33/1550x16.5 - Tire	36 psi (2.53 kg/cm ²)
Drive Speed	4.5 mph (7.2 kph)
Axle Oscillation	4 in. (0.1 m)
Turning Radius	
Inside	6.5 ft. (2.0 m)
Outside	16.4 ft. (5.0 m)
System Voltage	12 Volts
Max. Hydraulic System Operating Pressure	4500 psi (310 bar)
Gross Machine Weight	16,104 lbs. (7305 kg)

Capacities

Table 6-10. Capacities

Fuel Tank	17 gallons (64.3 liters)
Hydraulic Tank (machines to S/N 0300070586)	28 gallons (106 liters)
Hydraulic Tank (S/N 0300070586 & SN 1300000001 to Present)	27 gallons (102 liters) 23.6 gal. (89 liters) to the Full line on the sight gauge
Drive Hub	23.75 oz. (0.7 liters)
Drive Brake	2.7 oz. (0.08 liters)

Tires

Table 6-11. Tires

Size	Type	Pressure	Weight
12x16.5	Pneumatic	90 psi (6 Bar)	128 lbs. (58 kg)
12x16.5	Foam-Filled	N/A	328 lbs. (149 kg)
33/1550x16.5	Pneumatic	90 psi (6 Bar)	135 lbs. (61 kg)
33/1550x16.5	Foam-Filled	N/A	395 lbs. (179 kg)
14 x 16.1	Pneumatic	40 lbs. (3 bar)	91.5 lbs. (41.5 kg)
14 x 16.1	Foam-Filled	N/A	426 lbs. (193 kg)
33 x 6 x 11	Solid	N/A	280 lbs. (127 kg)

SECTION 6 - GENERAL SPECIFICATIONS & OPERATOR MAINTENANCE

Engine

NOTE: RPM Tolerances are ± 100 .

Table 6-12. Ford LRG-425 (Gas or Dual Fuel)

Type	4 cylinder, 4 stroke, spark ignition
Fuel	Gasoline or Gasoline/LP Gas
Bore	3 in. (96 mm)
Stroke	3.4 in. (86.4 mm)
Displacement	153 cu. in. (2.5 L)
Firing Order	1-3-4-2
BHP at Max. RPM	82
Oil Capacity	4.5 quarts (4.26 L)
Low RPM	1000
Mid RPM	
Tower Lift, Upper Lift, Tele	1800
Swing, Basket Level, Basket	1500
Rotate, Jib Lift	
High RPM	3000
Spark Plug	AWSF-52-C
Spark Plug Gap	0.044 in. (1.117 mm)

Table 6-13. Deutz F3M1011F

Fuel	Diesel
No. of Cylinders	3
Bore	3.6 in. (91 mm)
Stroke	4.4 in. (112 mm)
Displacement	133 cu. in. (2184 cm ³)
BHP at Max. RPM	48
Oil Capacity	
crankcase	6.3 quarts (6 L)
cooler	4.75 quarts (4.5 L)
total capacity	11 quarts (10.5 L)
Low RPM	1200
Mid RPM	
Tower Lift, Upper Lift, Tele	
Swing, Basket Level, Basket	1800
Rotate, Jib Lift	1500
High RPM	2800

SECTION 6 - GENERAL SPECIFICATIONS & OPERATOR MAINTENANCE

Table 6-14. Deutz F3M2011F/D2011L03

Fuel	Diesel
No. of Cylinders	3
Bore	3.7 in. (94 mm)
Stroke	4.4 in. (112 mm)
Displacement	142 cu. in. (2331 cm ³)
Oil Capacity	
crankcase	6.3 quarts (6 L)
cooler	4.75 quarts (4.5 L)
total capacity	11 quarts (10.5 L)
Low RPM	1200
Mid RPM	
Tower Lift, Upper Lift, Tele	1800
Swing, Basket Level, Basket	1500
Rotate, Jib Lift	
High RPM	2800

Table 6-15. Caterpillar 3024/C2.2

Fuel	Diesel
No. of Cylinders	4
BHP	46.5 hp (34 kW)
Bore	3.307 in. (84 mm)
Stroke	3.9370 in. (112 mm)
Displacement	134.3 cu. in. (2.2L)
Oil Capacity	3.8 quarts (3.6L) crankcase only
Compression Ratio	19:1
Firing Order	1-3-4-2
Max. RPM	2800

SECTION 6 - GENERAL SPECIFICATIONS & OPERATOR MAINTENANCE

Table 6-16. GM 3.0L

Fuel	Gasoline or Gasoline/LP Gas
No. of Cylinders	4
BHP	
Gasoline	83 hp @ 3000 rpm
LP	75 hp @ 3000 rpm
Bore	4.0 in. (101.6 mm)
Stroke	3.6 in. (91.44 mm)
Displacement	181 cu.in. (3.0 L, 2966 cc)
Oil Capacity w/filter	4.5 qts. (4.25 L)
Minimum Oil Pressure	
at idle	6 psi (0.4 Bar) @ 1000 rpm
Hot	18 psi (1.2 Bar) @ 2000 rpm
Compression Ratio	9.2:1
Firing Order	1-3-4-2
Max. RPM	2800

Table 6-17. Perkins 404D-22

Fuel	Diesel
No. of Cylinders	4
BHP	50 HP (37.3 kW)
Bore	3.3 in. (84 mm)
Stroke	3.9 in. (100 mm)
Firing Order	1-3-4-2
Displacement	135 cu.in. (2.2 L)
Oil Capacity w/filter	10 qt. (9.4 L)
Compression Ratio	23.3:1

Major Component Weights

Table 6-18. Component Weights - 450

Component	Pounds	Kilograms
Frame (Bare)	2325	1055
Turntable (Bare)	1500	680
Boom Link	180	82
Boom Timing Link	30	14
Upper Upright	217	98
Lower Upright	115	52
Lower Boom	497	225
Mid Boom	385	175
Upper Boom	1065	484
4 Wheel Drive Axle	200	91
2 Wheel Drive Axle	235	107

Table 6-19. Component Weights - 510

Component	Pounds	Kilograms
Engine Only	440	200
Upper Boom	1257	570
Frame (Bare)	2105	955
Turntable (Bare)	1533	695.5

Hydraulic Oil

Table 6-20. Hydraulic Oil

Hydraulic System Operating Temperature Range	S.A.E. Viscosity Grade
+0° to +180° F (-18° to +83° C)	10W
+0° to +210° F (-18° to +99° C)	10W-20, 10W30
+50° to +210° F (+10° to +99° C)	20W-20

NOTE: Hydraulic oils must have anti-wear qualities at least to API Service Classification GL-3, and sufficient chemical stability for mobile hydraulic system service. JLG Industries recommends Mobilfluid 424 hydraulic oil, which has an SAE viscosity index of 152.

NOTE: When temperatures remain consistently below 20 degrees F. (-7 degrees C.), JLG Industries recommends the use of Mobil DTE13.

SECTION 6 - GENERAL SPECIFICATIONS & OPERATOR MAINTENANCE

Aside from JLG recommendations, it is not advisable to mix oils of different brands or types, as they may not contain the same required additives or be of comparable viscosities. If use of hydraulic oil other than Mobilfluid 424 is desired, contact JLG Industries for proper recommendations.

Table 6-21. Mobilfluid 424 Specs

SAE Grade	10W30
Gravity, API	29.0
Density, Lb/Gal. 60°F	7.35
Pour Point, Max	-46°F (-43°C)
Flash Point, Min.	442°F (228°C)
Viscosity	
Brookfield, cP at -18°C	2700
at 40° C	55 cSt
at 100° C	9.3 cSt
Viscosity Index	152

Table 6-22. Mobil DTE 13M Specs

ISO Viscosity Grade	#32
Specific Gravity	0.877
Pour Point, Max	-40°F (-40°C)
Flash Point, Min.	330°F (166°C)
Viscosity	
at 40° C	33cSt
at 100° C	6.6 cSt
at 100° F	169 SUS
at 210° F	48 SUS
cp at -20° F	6,200
Viscosity Index	140

SECTION 6 - GENERAL SPECIFICATIONS & OPERATOR MAINTENANCE

Table 6-23. UCon Hydrolube HP-5046

Type	Synthetic Biodegradable
Specific Gravity	1.082
Pour Point, Max	-58°F (-50°C)
pH	9.1
Viscosity	
at 0° C (32° F)	340 cSt (1600SUS)
at 40° C (104° F)	46 cSt (215SUS)
at 65° C (150° F)	22 cSt (106SUS)
Viscosity Index	170

Table 6-24. Mobil EAL H 46 Specs

Type	Synthetic Biodegradable
ISO Viscosity Grade	46
Specific Gravity	.910
Pour Point	-44°F (-42°C)
Flash Point	500°F (260°C)
Operating Temp.	0 to 180°F (-17 to 162°C)
Weight	7.64 lb. per gal. (0.9 kg per liter)
Viscosity	
at 40° C	45 cSt
at 100° C	8.0 cSt
Viscosity Index	153

SECTION 6 - GENERAL SPECIFICATIONS & OPERATOR MAINTENANCE

Table 6-25. Exxon Univis HVI 26 Specs

Specific Gravity	32.1
Pour Point	-76°F (-60°C)
Flash Point	217°F (103°C)
Viscosity	
at 40° C	25.8 cSt
at 100° C	9.3 cSt
Viscosity Index	376
NOTE: <i>Mobil/Exxon recommends that this oil be checked on a yearly basis for viscosity.</i>	

Table 6-26. Quintolubric 888-46

Density	0.91 @ 15°C (59°F)
Pour Point	<-20°C (<-4°F)
Flash Point	275°C (527°F)
Fire Point	325°C (617°F)
Autoignition Temperature	450°C (842°F)
Viscosity	
at 0° C (32°F)	360 cSt
at 20° C (68°F)	102 cSt
at 40° C (104°F)	46 cSt
at 100° C (212°F)	10 cSt
Viscosity Index	220

Serial Number Location

A serial number plate is affixed to the left rear side of the frame.
If the serial number plate is damaged or missing, the machine serial number is stamped on the left side of the frame.

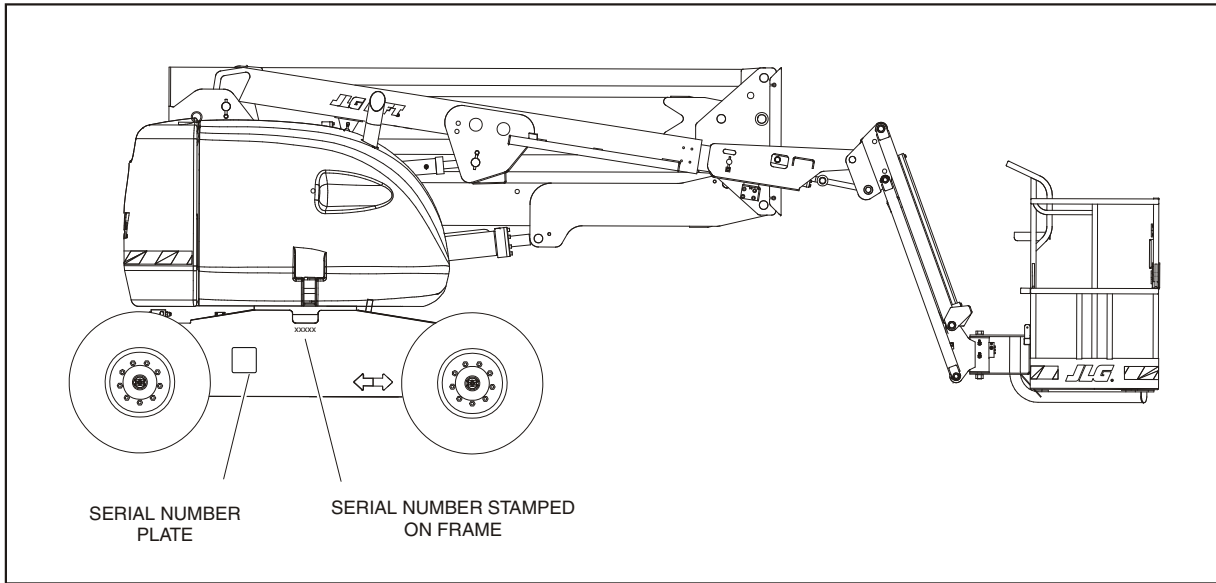

Figure 6-1. Serial Number Locations

SECTION 6 - GENERAL SPECIFICATIONS & OPERATOR MAINTENANCE

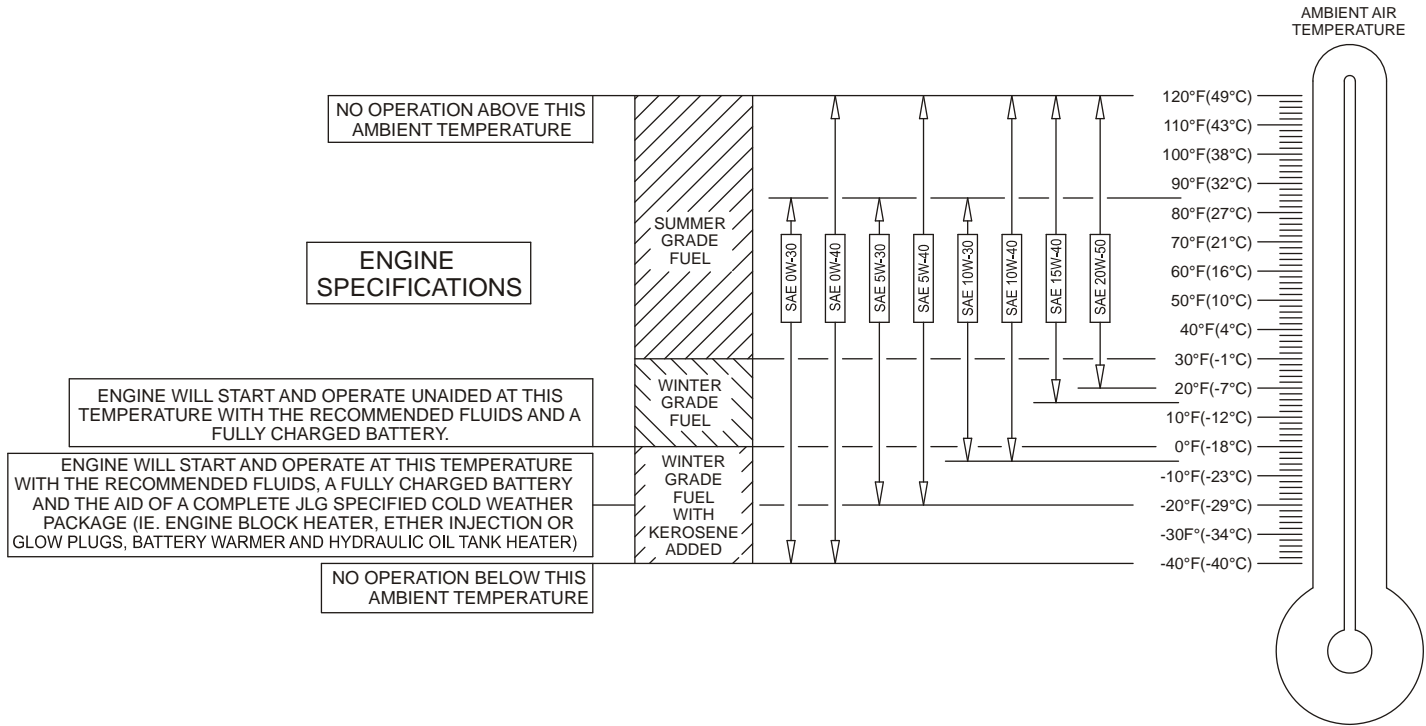

Figure 6-2. Engine Operating Temperature Specifications - Deutz - Sheet 1 of 2

SECTION 6 - GENERAL SPECIFICATIONS & OPERATOR MAINTENANCE

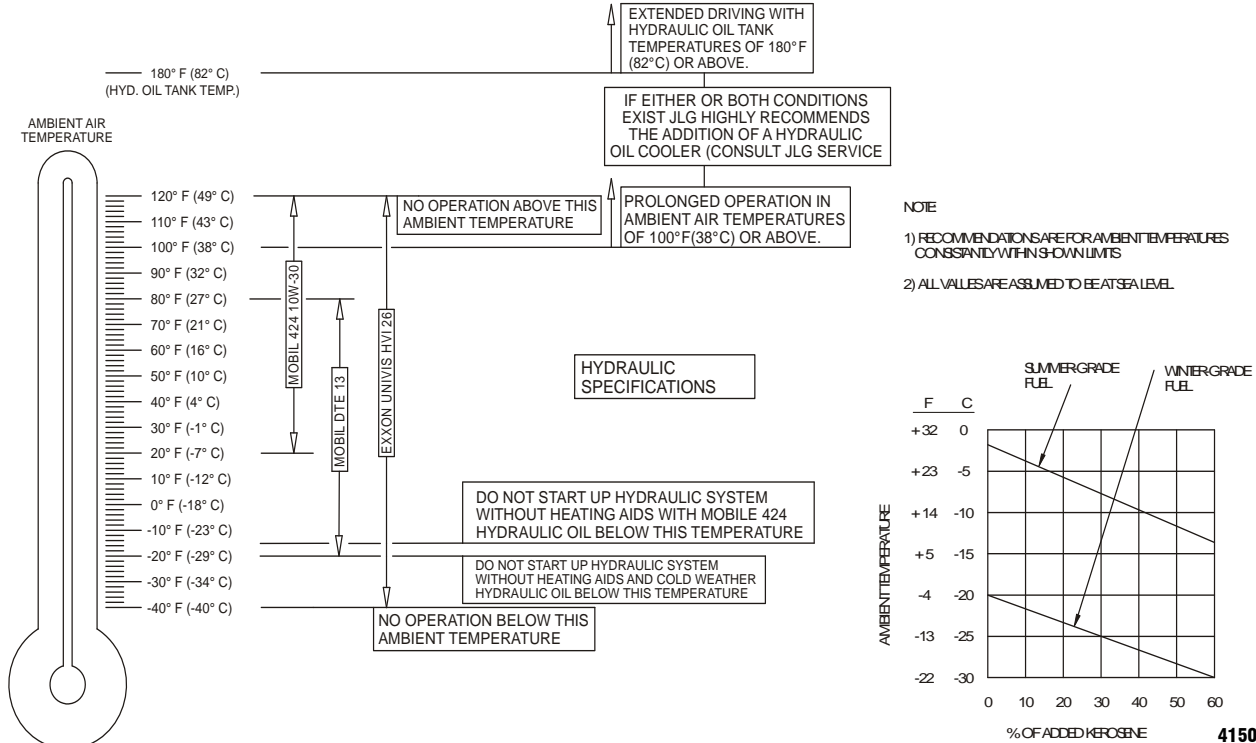

Figure 6-3. Engine Operating Temperature Specifications - Deutz - Sheet 2 of 2

SECTION 6 - GENERAL SPECIFICATIONS & OPERATOR MAINTENANCE

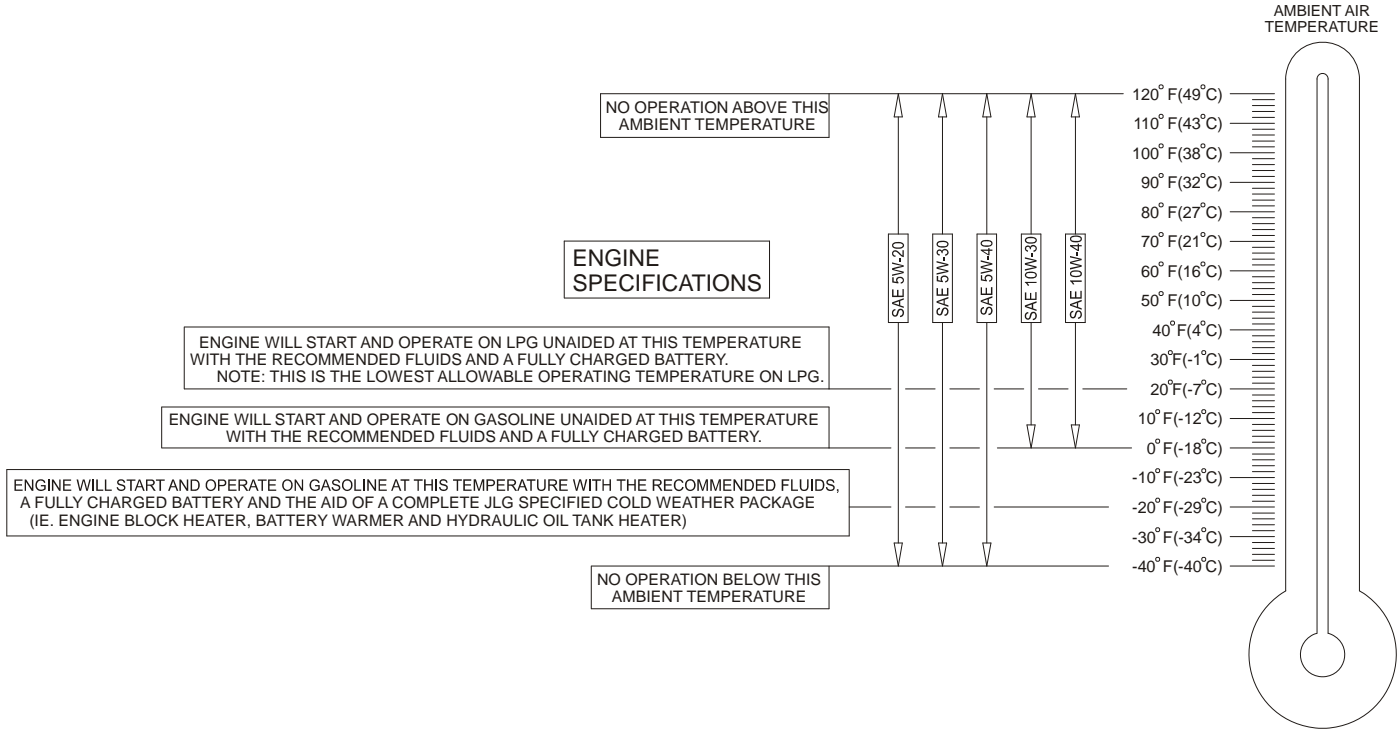
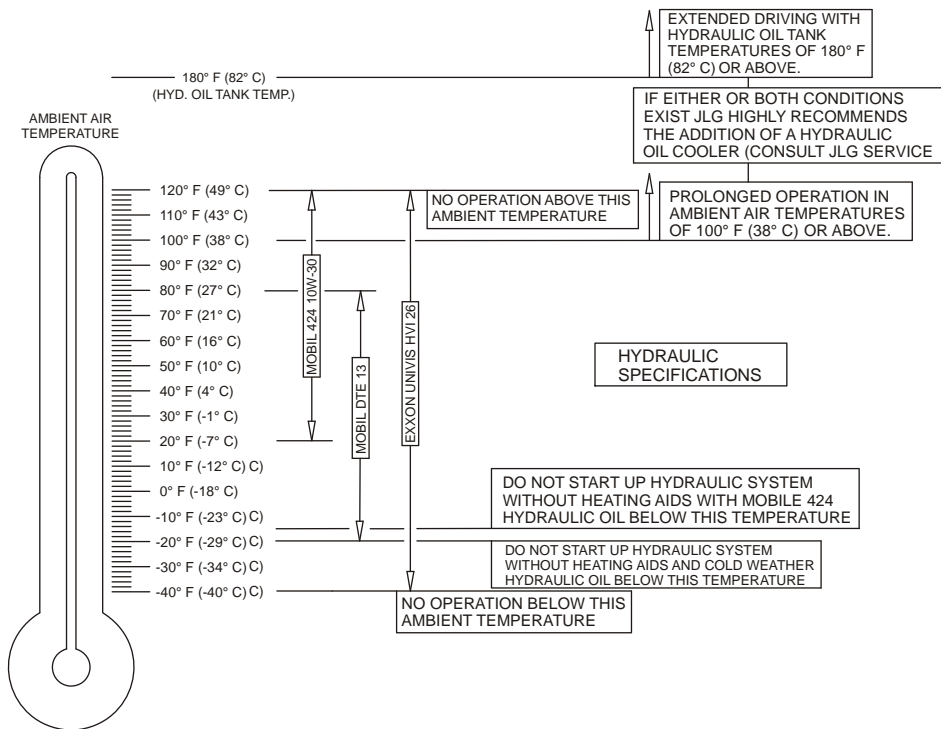

Figure 6-4. Engine Operating Temperature Specifications - Ford - Sheet 1 of 2

SECTION 6 - GENERAL SPECIFICATIONS & OPERATOR MAINTENANCE



NOTE:

- 1) RECOMMENDATIONS ARE FOR AMBIENT TEMPERATURES CONSISTANTLY WITHIN SHOWN LIMITS
- 2) ALL VALUES ARE ASSUMED TO BE AT SEA LEVEL.

Figure 6-5. Engine Operating Temperature Specifications - Ford - Sheet 2 of 2

4150548-E

SECTION 6 - GENERAL SPECIFICATIONS & OPERATOR MAINTENANCE

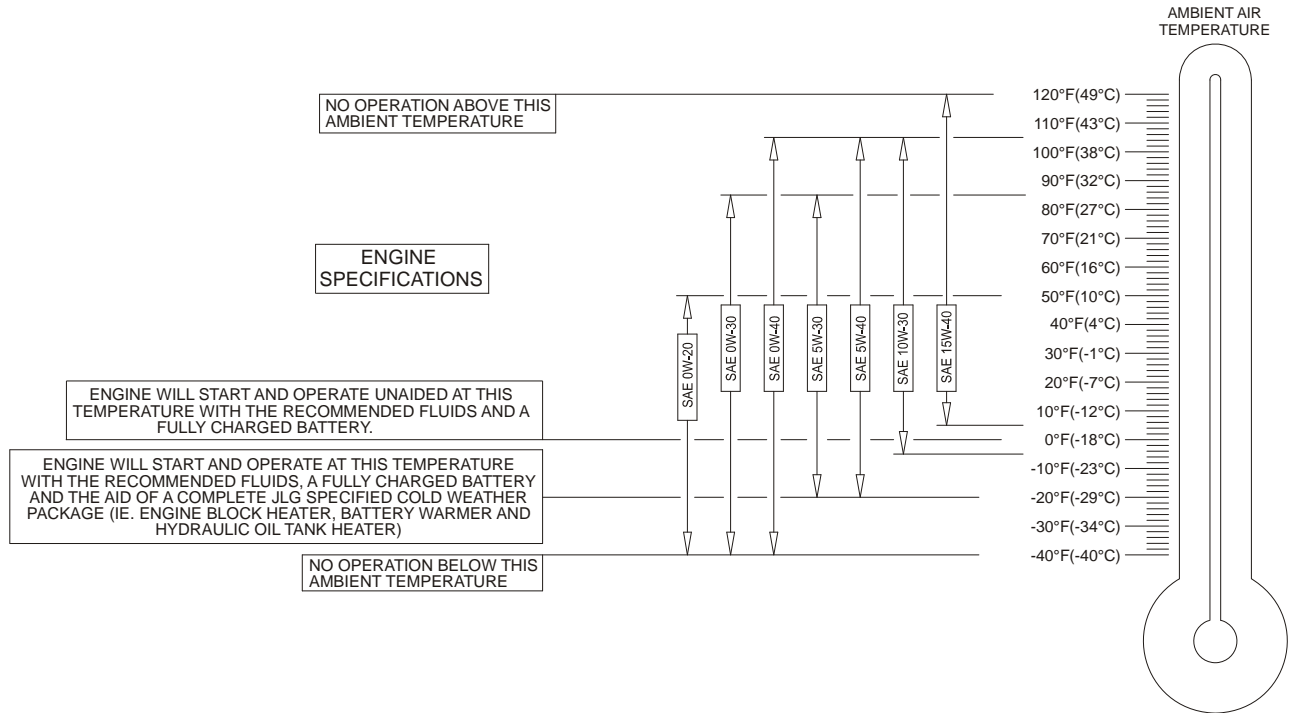
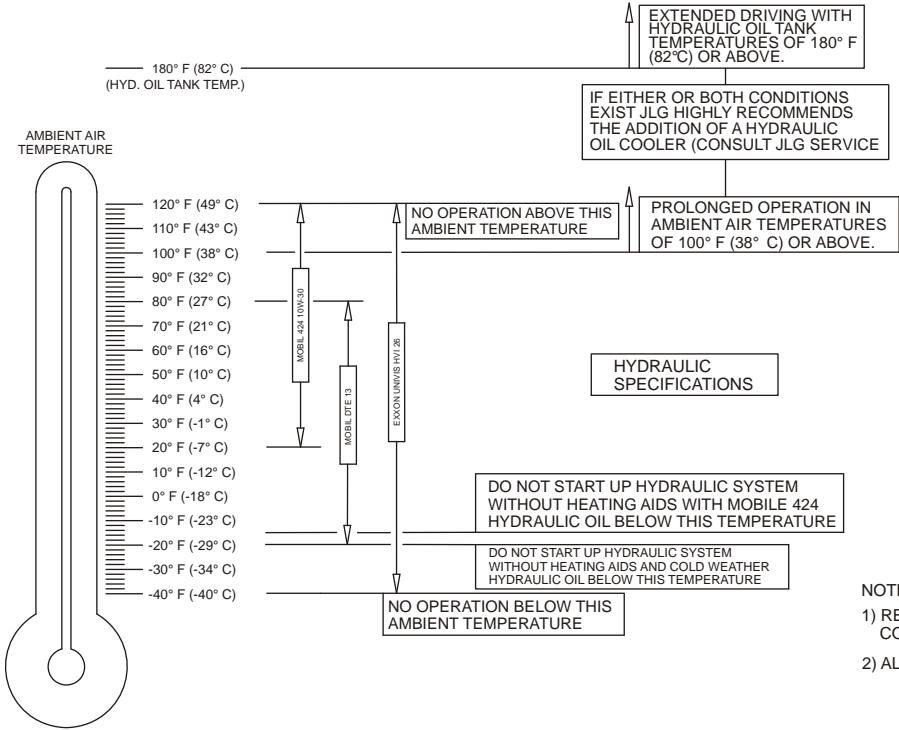

Figure 6-6. Engine Operating Temperature Specifications - Caterpillar - Sheet 1 of 2

SECTION 6 - GENERAL SPECIFICATIONS & OPERATOR MAINTENANCE



- NOTE:
- 1) RECOMMENDATIONS ARE FOR AMBIENT TEMPERATURES CONSISTENTLY WITHIN SHOWN LIMITS
 - 2) ALL VALUES ARE ASSUMED TO BE AT SEA LEVEL.

Figure 6-7. Engine Operating Temperature Specifications - Caterpillar - Sheet 2 of 2

4150548-E

SECTION 6 - GENERAL SPECIFICATIONS & OPERATOR MAINTENANCE

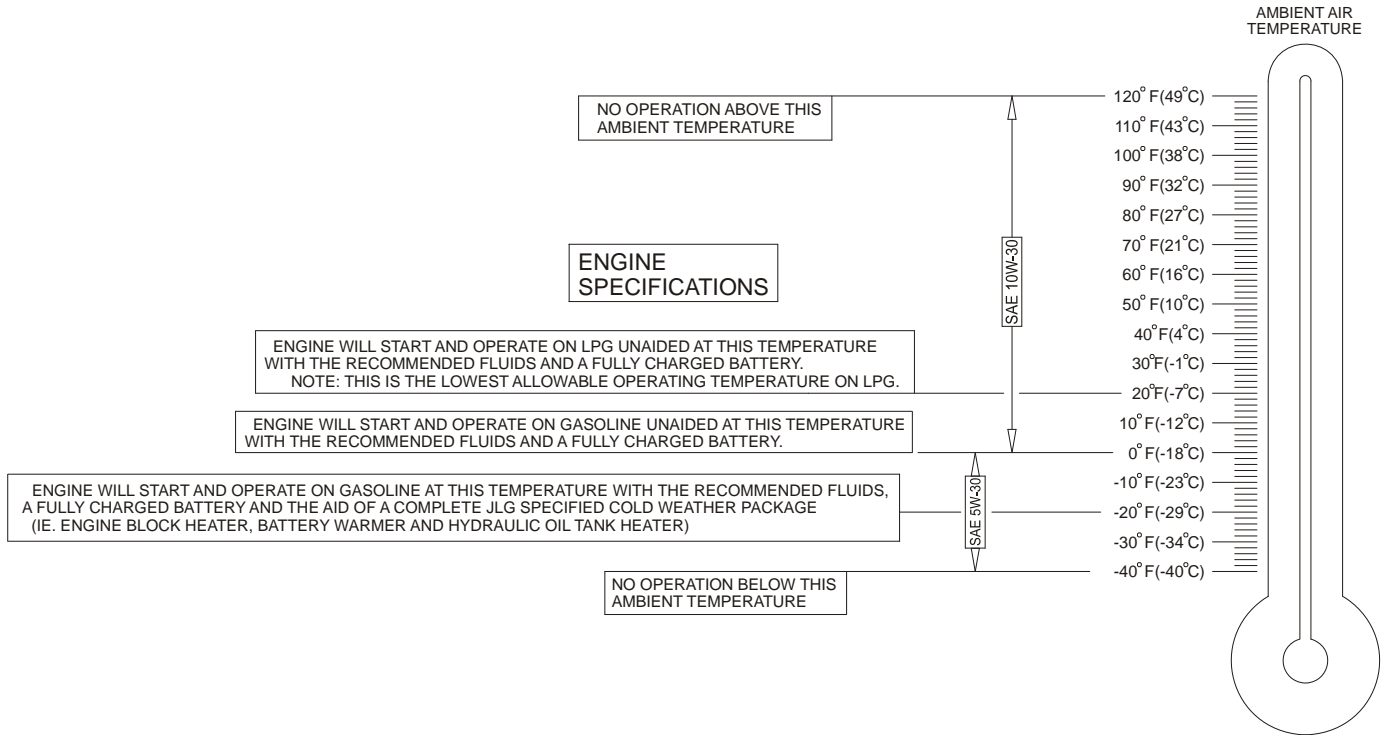
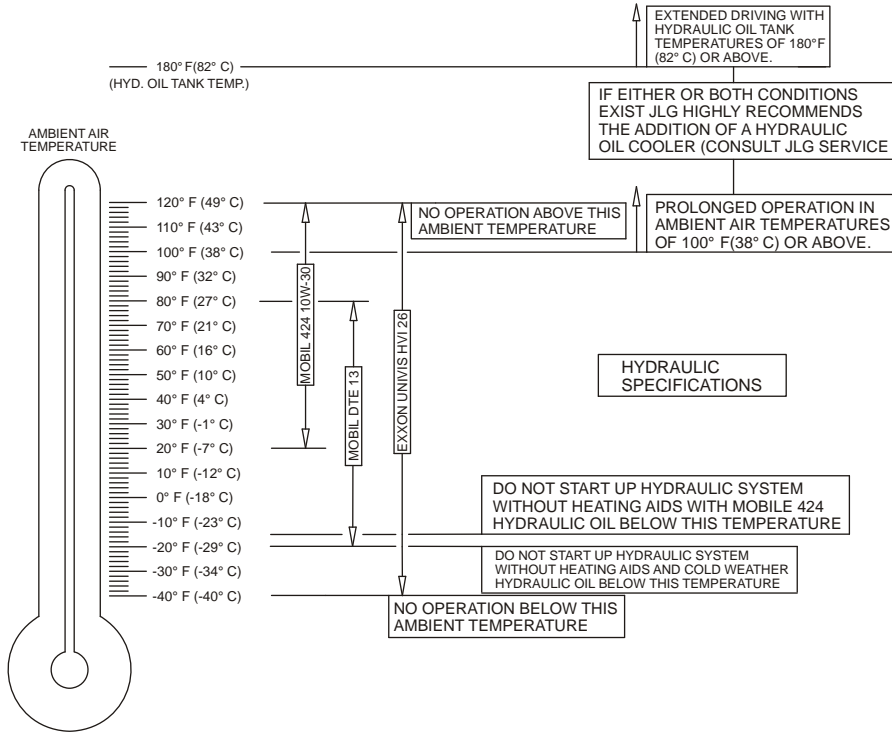

Figure 6-8. Engine Operating Temperature Specifications - GM - Sheet 1 of 2

SECTION 6 - GENERAL SPECIFICATIONS & OPERATOR MAINTENANCE



NOTE:

- 1) RECOMMENDATIONS ARE FOR AMBIENT TEMPERATURES CONSISTENTLY WITHIN SHOWN LIMITS
- 2) ALL VALUES ARE ASSUMED TO BE AT SEA LEVEL.

Figure 6-9. Engine Operating Temperature Specifications - GM - Sheet 2 of 2

4150548-E

SECTION 6 - GENERAL SPECIFICATIONS & OPERATOR MAINTENANCE

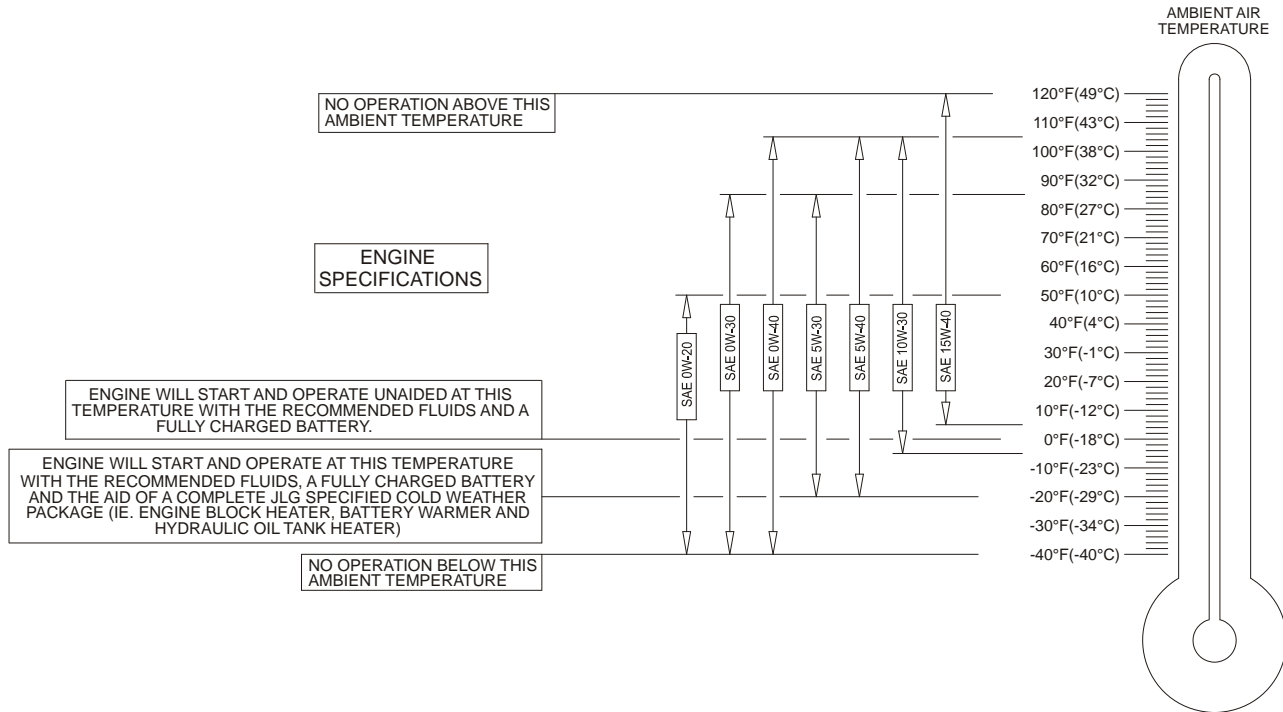
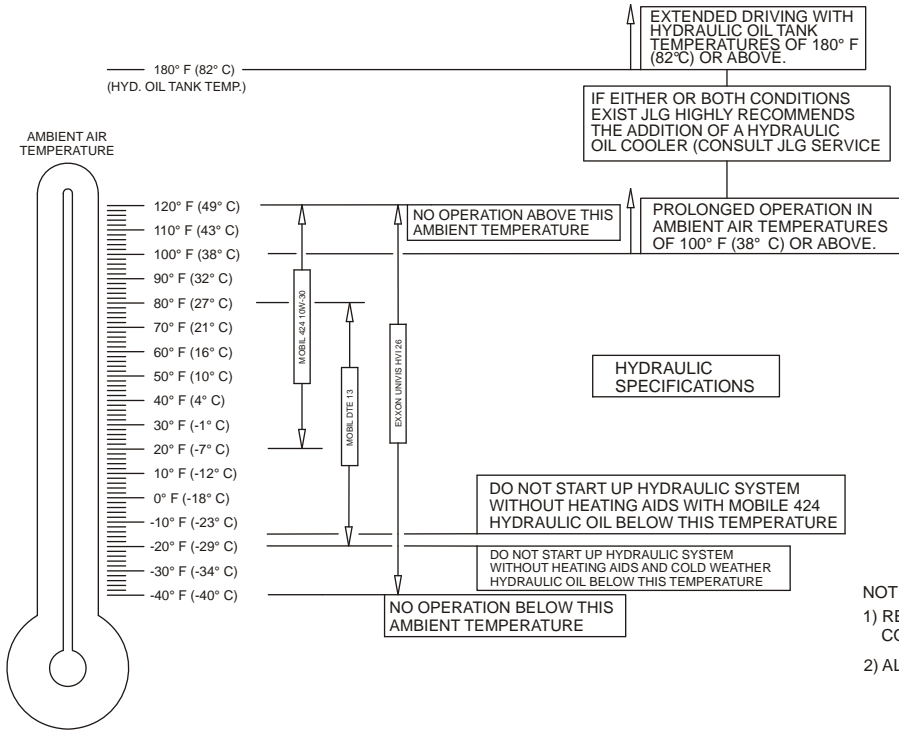

Figure 6-10. Engine Operating Temperature Specifications - Perkins - Sheet 1 of 2

SECTION 6 - GENERAL SPECIFICATIONS & OPERATOR MAINTENANCE



- NOTE:
- 1) RECOMMENDATIONS ARE FOR AMBIENT TEMPERATURES CONSISTENTLY WITHIN SHOWN LIMITS
 - 2) ALL VALUES ARE ASSUMED TO BE AT SEA LEVEL.

Figure 6-11. Engine Operating Temperature Specifications - Perkins - Sheet 2 of 2

4150548-E

SECTION 6 - GENERAL SPECIFICATIONS & OPERATOR MAINTENANCE

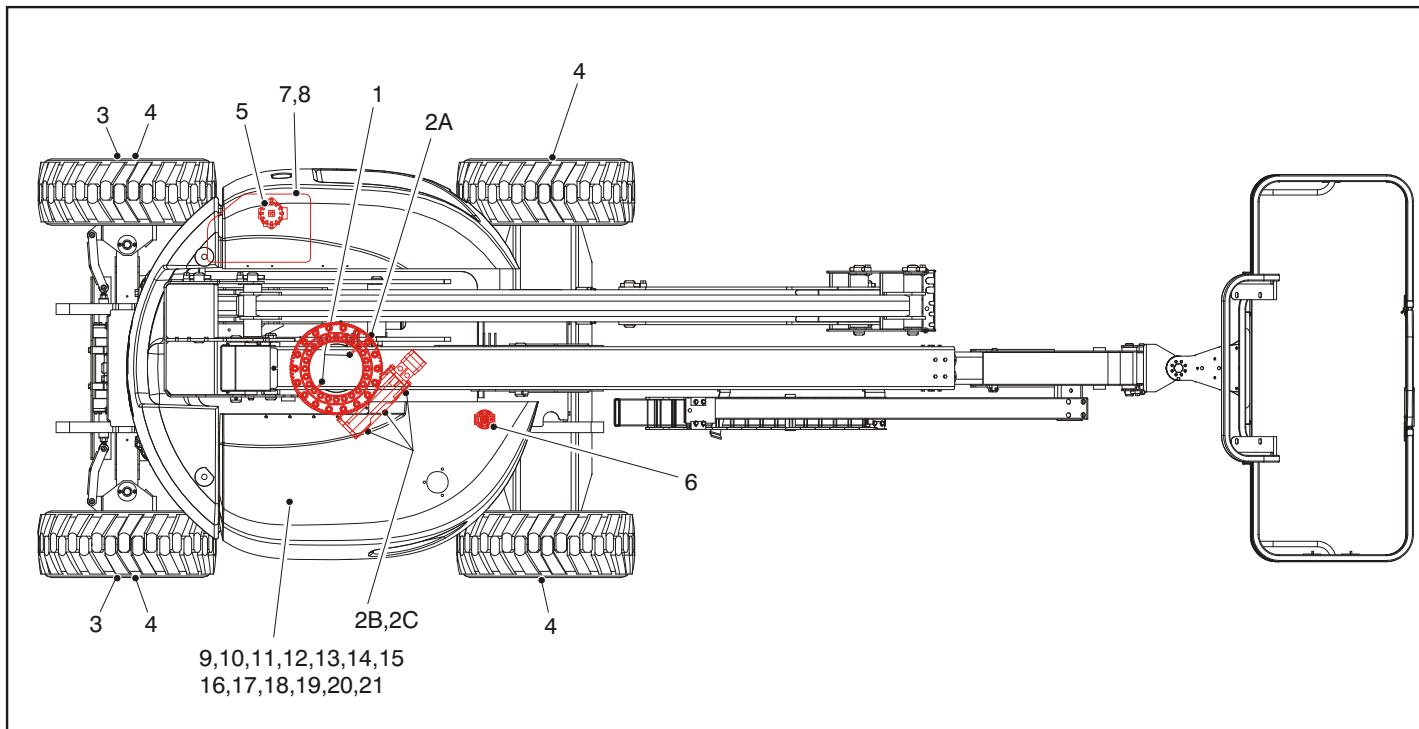

Figure 6-12. Operator Maintenance and Lubrication Diagram

6.3 OPERATOR MAINTENANCE

NOTE: The following numbers correspond to those in Figure 6-12., Operator Maintenance and Lubrication Diagram.

Table 6-27. Lubrication Specifications

KEY	SPECIFICATIONS
MPG	Multipurpose Grease having a minimum dripping point of 350° F (177° C). Excellent water resistance and adhesive qualities, and being of extreme pressure type. (Timken OK 40 pounds minimum.)
EPGL	Extreme Pressure Gear Lube (oil) meeting API service classification GL-5 or MIL-Spec MIL-L-2105
HO	Hydraulic Oil. API service classification GL-3, e.g. Mobilfluid 424.
EO	Engine (crankcase) Oil. Gas - API SF, SH, SG class, MIL-L-2104. Diesel - API CC/CD class, MIL-L-2104B/MIL-L-2104C.
OGL	Open Gear Lubricant - Mobiltac 375 or equivalent.

NOTICE

LUBRICATION INTERVALS ARE BASED ON MACHINE OPERATION UNDER NORMAL CONDITIONS. FOR MACHINES USED IN MULTI-SHIFT OPERATIONS AND/OR EXPOSED TO HOSTILE ENVIRONMENTS OR CONDITIONS, LUBRICATION FREQUENCIES MUST BE INCREASED ACCORDINGLY.

NOTE: *It is recommended as a good practice to replace all filters at the same time.*

1. Swing Bearing - Internal Ball Bearing

Lube Point(s) - 2 Grease Fittings
Capacity - A/R
Lube - MPG
Interval - Every 3 months or 150 hrs of operation

SECTION 6 - GENERAL SPECIFICATIONS & OPERATOR MAINTENANCE

2. A. Swing Bearing - Teeth
(Prior to S/N 0300069337)

Lube Point(s) - Spray On

Capacity - A/R

Lube - OGL

Interval - Every 3 months or 150 hrs of operation

Comments - More frequent lubrication intervals may be required

- B. End Bearings - Worm Gear*
(Prior to S/N 0300069337)

Lube Point(s) - 2 Grease Fittings

Capacity - A/R

Lube - MPG

Interval - Every 2 years or 1200 hrs of operation

Comments - Remove grease fittings and install plugs after greasing

*If necessary install grease fittings into worm gear housing and grease bearings.



DO NOT OVERGREASE END BEARINGS. OVERGREASING BEARINGS WILL RESULT IN BLOWING OUTER SEAL IN HOUSING.

- C. Swing Bearing/Worm Gear Teeth*
(S/N 0300069337 to 0300077285 USA and
S/N 1300000001 to 1300000353 Belgium)

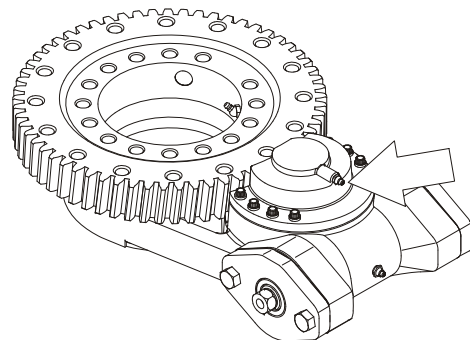

Lube Point(s) - Grease Fitting

Capacity - A/R

Lube - Mobil SHC 460

Interval - A/R

SECTION 6 - GENERAL SPECIFICATIONS & OPERATOR MAINTENANCE

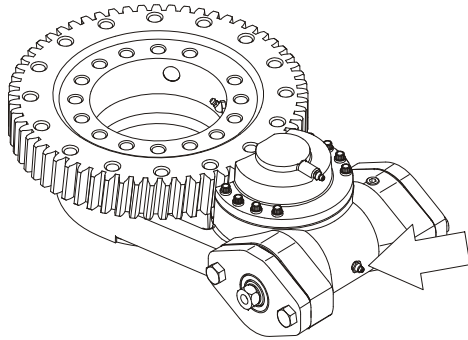

Lube Point(s) - Grease Fitting
Capacity - A/R
Lube - Mobile SHC 007
Interval - A/R



DO NOT OVERGREASE BEARINGS. OVERGREASING BEARINGS WILL RESULT IN DAMAGE TO OUTER SEAL IN HOUSING.

Swing Bearing/Worm Gear Teeth
(S/N 0300077285 to Present USA and
S/N 1300000353 to Present Belgium)

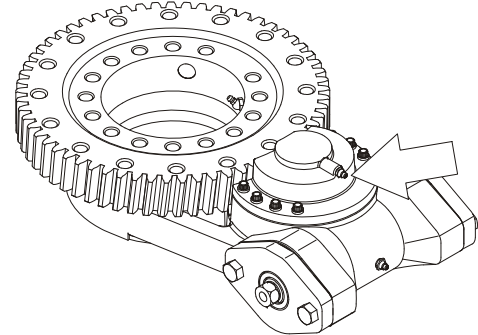

Lube Point(s) - Grease Fitting
Capacity - A/R
Lube - Lubriplate 930-AAA
Interval - A/R

SECTION 6 - GENERAL SPECIFICATIONS & OPERATOR MAINTENANCE

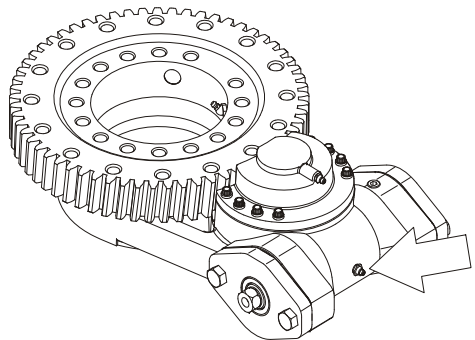

Lube Point(s) - Grease Fitting*
Capacity - A/R
Lube - Mobile SHC 007
Interval - A/R

⚠ CAUTION

DO NOT OVERGREASE BEARINGS. OVERGREASING BEARINGS WILL RESULT IN DAMAGE TO OUTER SEAL IN HOUSING.

*If necessary install grease fitting into worm gear housing and grease. Replace fitting with pipe plug when complete.

3. Wheel Bearings (2WD Only)

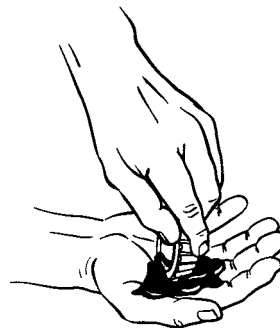

Lube Point(s) - Repack
Capacity - A/R
Lube - MPG
Interval - Every 2 years or 1200 hours of operation

4. Wheel Drive Hub

Lube Point(s) - Level/Fill Plug
Capacity - 17 oz. (0.5 L) - 1/2 Full
Lube - EPGL
Interval - Check level every 3 months or 150 hrs of operation; change every 2 years or 1200 hours of operation

SECTION 6 - GENERAL SPECIFICATIONS & OPERATOR MAINTENANCE

5. Hydraulic Return Filter

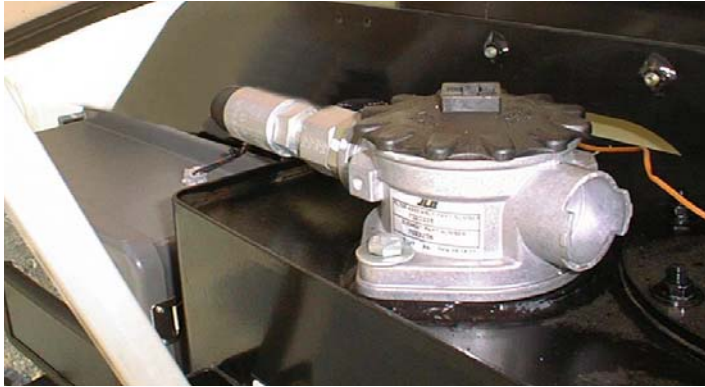

Interval - Change after first 50 hrs. and every 6 months or 300 hrs. thereafter or as indicated by Condition Indicator.

6. Hydraulic Charge Filter



Interval - Change after first 50 hrs. and every 6 months or 300 hrs. thereafter or as indicated by Condition Indicator.

SECTION 6 - GENERAL SPECIFICATIONS & OPERATOR MAINTENANCE

7. Hydraulic Tank

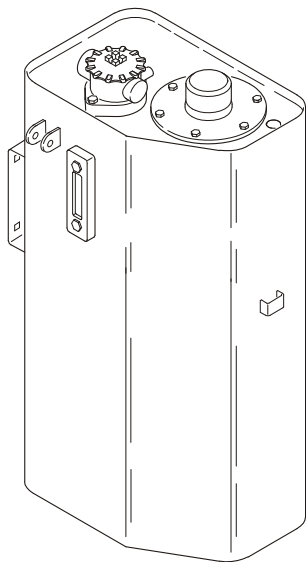

Lube Point(s) - Fill Cap

Capacity - 27 gallons (102 liters); 23.6 gal. (89 liters) to the Full line on the sight gauge

Lube - HO

Interval - Check Level daily; Change every 2 years or 1200 hours of operation.

8. Suction Strainers

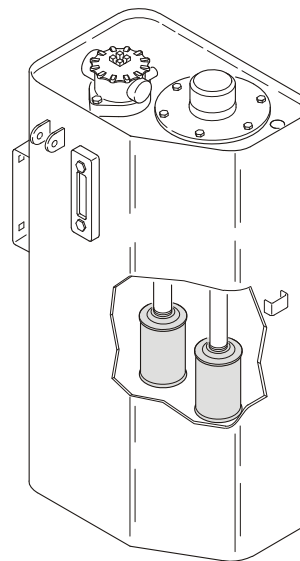

Lube Point(s) - 2

Interval - Every 2 years or 1200 hours of operation, remove and clean at time of hydraulic oil change.

SECTION 6 - GENERAL SPECIFICATIONS & OPERATOR MAINTENANCE

9. Oil Change w/Filter - Ford

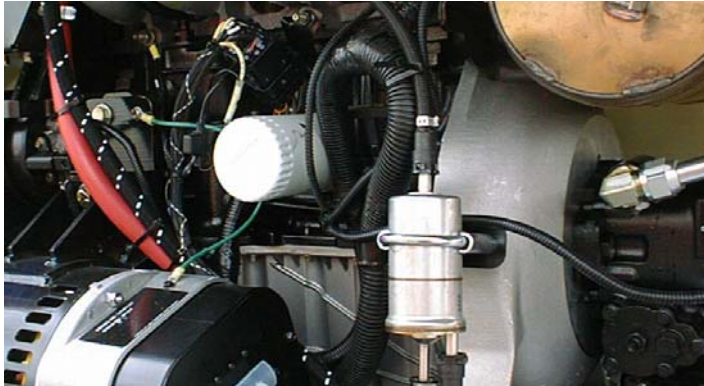

Lube Point(s) - Fill Cap/Spin-on Element (JLG P/N 7014501)

Capacity - 4.5 Quarts (4.25 L)

Lube - EO

Interval - 3 Months or 150 hours of operation

Comments - Check level daily/Change in accordance with engine manual.

10. Oil Change w/Filter - Deutz



Fill Cap/Spin-on Element (JLG P/N 7016641)

Capacity - 11 Quarts(10.5 L) Crankcase; 5 Quarts (4.7 L) Cooler

Lube - EO

Interval - Every Year or 1200 hours of operation

Comments - Check level daily/Change in accordance with engine manual.

SECTION 6 - GENERAL SPECIFICATIONS & OPERATOR MAINTENANCE

11. Oil Change w/Filter - Caterpillar

Lube Point(s) - Fill Cap/Spin-on Element (JLG P/N 7026855)

Capacity - 10 Quarts (9.4 L)

Lube - EO

Interval - Every Year or 500 hours of operation

Comments - Check level daily/Change in accordance with engine manual.

12. Oil Change w/Filter - GM



Lube Point(s) - Fill Cap/Spin-on Element
(JLG P/N 7027965)

Capacity - 4.5 qt. (4.25 L) w/filter

Lube - EO

Interval - 3 Months or 150 hours of operation

Comments - Check level daily/Change in accordance with engine manual.

SECTION 6 - GENERAL SPECIFICATIONS & OPERATOR MAINTENANCE

13. Oil Change w/Filter - Perkins

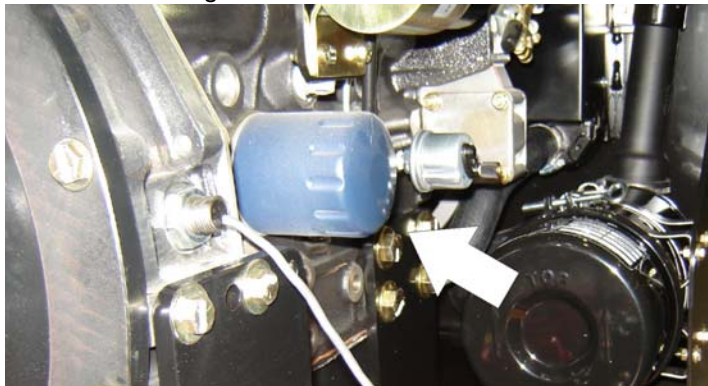

Lube Point(s) - Fill Cap/Spin-on Element (JLG P/N 7026855)
Capacity - 10 Quarts (9.4 L)
Lube - EO
Interval - Every Year or 500 hours of operation
Comments - Check level daily/Change in accordance with engine manual.

14. Fuel Filter - Ford

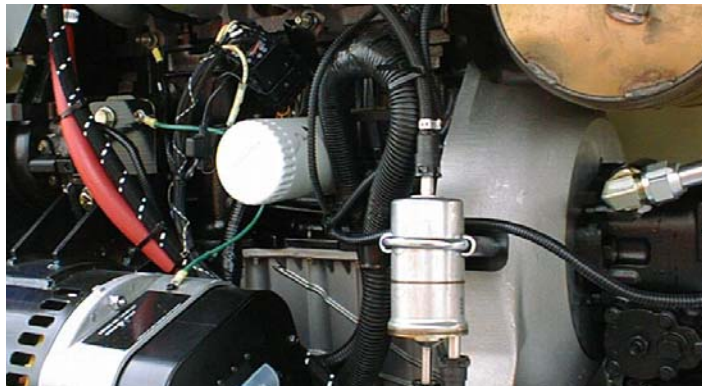

Lube Point(s) - Replaceable Element
Interval - Every Year or 1200 hours of operation

SECTION 6 - GENERAL SPECIFICATIONS & OPERATOR MAINTENANCE

15. Fuel Filter - Deutz

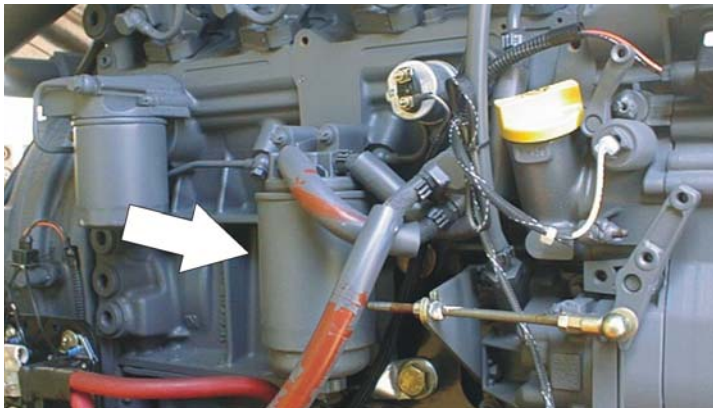

Lube Point(s) - Replaceable Element
Interval - Every Year or 600 hours of operation

16. Fuel Filter - Caterpillar

Lube Point(s) - Replaceable Element
Interval - Every Year or 600 hours of operation

17. Fuel Filter - GM

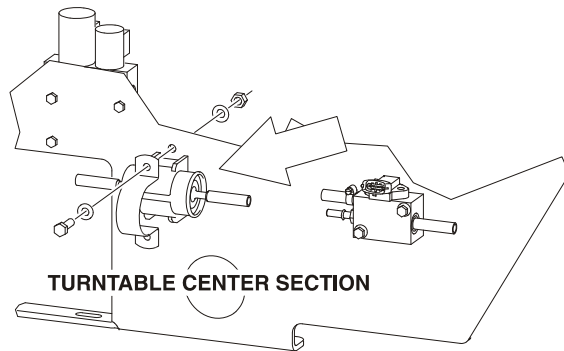

Lube Point(s) - Replaceable Element
Interval - Every 6 months or 300 hours of operation

SECTION 6 - GENERAL SPECIFICATIONS & OPERATOR MAINTENANCE

18. Fuel Filter - Perkins



Lube Point(s) - Replaceable Element
Interval - Every Year or 600 hours of operation

19. Air Filter

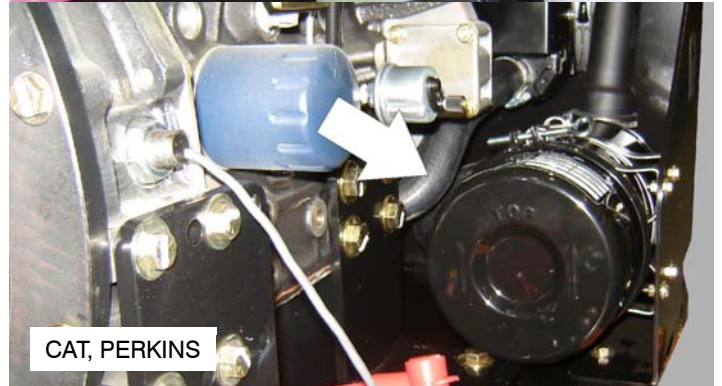

SECTION 6 - GENERAL SPECIFICATIONS & OPERATOR MAINTENANCE

Lube Point(s) - Replaceable Element

Interval - Every 6 months or 300 hours of operation or as indicated by the condition indicator

20. Electronic Pressure Regulator (LP only)

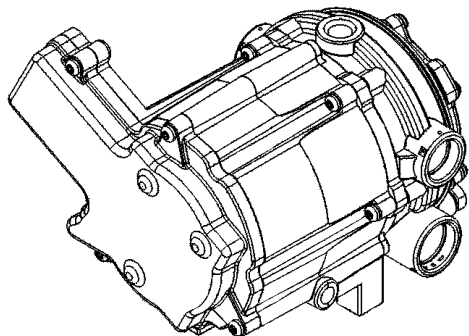

Interval - 3 Months or 150 hours of operation

Comments - Drain oil build up. Refer to Section 6.5, DRAINING OIL BUILD UP FROM THE PROPANE REGULATOR (Prior to S/N 0300137808)

21. Fuel Filter (Propane) - GM Engine



Interval - 3 Months or 150 hours of operation

Comments - Replace filter. Refer to Section 6.6, Propane Fuel Filter Replacement

6.4 TIRES & WHEELS

Tire Inflation

The air pressure for pneumatic tires must be equal to the air pressure that is stenciled on the side of the JLG product or rim decal for safe and proper operational characteristics.

Tire Damage

For pneumatic tires, JLG Industries, Inc. recommends that when any cut, rip, or tear is discovered that exposes sidewall or tread area cords in the tire, measures must be taken to remove the JLG product from service immediately. Arrangements must be made for replacement of the tire or tire assembly.

For polyurethane foam filled tires, JLG Industries, Inc. recommends that when any of the following are discovered, measures must be taken to remove the JLG product from service immediately and arrangements must be made for replacement of the tire or tire assembly.

- a smooth, even cut through the cord plies which exceeds 3 inches (7.5 cm) in total length
- any tears or rips (ragged edges) in the cord plies which exceeds 1 inch (2.5 cm) in any direction
- any punctures which exceed 1 inch in diameter

- any damage to the bead area cords of the tire

If a tire is damaged but is within the above noted criteria, the tire must be inspected on a daily basis to insure the damage has not propagated beyond the allowable criteria.

Tire Replacement

JLG recommends a replacement tire be the same size, ply and brand as originally installed on the machine. Please refer to the JLG Parts Manual for the part number of the approved tires for a particular machine model. If not using a JLG approved replacement tire, we recommend that replacement tires have the following characteristics:

- Equal or greater ply/load rating and size of original
- Tire tread contact width equal or greater than original
- Wheel diameter, width, and offset dimensions equal to the original
- Approved for the application by the tire manufacturer (including inflation pressure and maximum tire load)

Unless specifically approved by JLG Industries Inc. do not replace a foam filled or ballast filled tire assembly with a pneumatic tire. When selecting and installing a replacement tire, ensure that all tires are inflated to the pressure recommended

by JLG. Due to size variations between tire brands, both tires on the same axle should be the same.

Wheel Replacement

The rims installed on each product model have been designed for stability requirements which consist of track width, tire pressure, and load capacity. Size changes such as rim width, center piece location, larger or smaller diameter, etc., without written factory recommendations, may result in an unsafe condition regarding stability.

Wheel Installation

It is extremely important to apply and maintain proper wheel mounting torque.

WARNING

WHEEL NUTS MUST BE INSTALLED AND MAINTAINED AT THE PROPER TORQUE TO PREVENT LOOSE WHEELS, BROKEN STUDS, AND POSSIBLE DANGEROUS SEPARATION OF WHEEL FROM THE AXLE. BE SURE TO USE ONLY THE NUTS MATCHED TO THE CONE ANGLE OF THE WHEEL.

Tighten the lug nuts to the proper torque to prevent wheels from coming loose. Use a torque wrench to tighten the fasteners. If you do not have a torque wrench, tighten the fasteners with a lug wrench, then immediately have a service garage or dealer tighten the lug nuts to the proper torque. Over-tightening will result in breaking the studs or permanently deforming the mounting stud holes in the wheels. The proper procedure for attaching wheels is as follows:

1. Start all nuts by hand to prevent cross threading. DO NOT use a lubricant on threads or nuts.

SECTION 6 - GENERAL SPECIFICATIONS & OPERATOR MAINTENANCE

2. Tighten nuts in the following sequence:

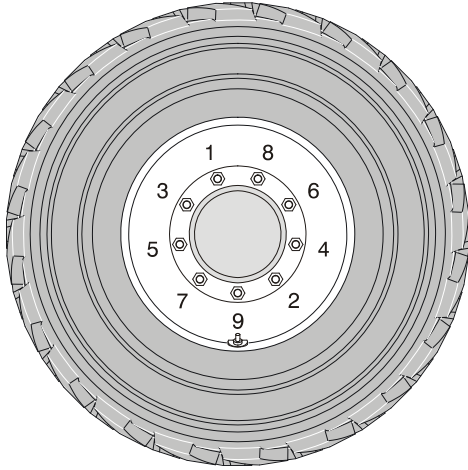

3. The tightening of the nuts should be done in stages. Following the recommended sequence, tighten nuts per wheel torque chart.

Table 6-28. Wheel Torque Chart

TORQUE SEQUENCE		
1st Stage	2nd Stage	3rd Stage
40 ft. lbs. (55 Nm)	100 ft. lbs. (130 Nm)	170 ft. lbs. (255 Nm)

4. Wheel nuts should be torqued after first 50 hours of operation and after each wheel removal. Check torque every 3 months or 150 hours of operation.

SECTION 6 - GENERAL SPECIFICATIONS & OPERATOR MAINTENANCE

6.5 DRAINING OIL BUILD UP FROM THE PROPANE REGULATOR (PRIOR TO S/N 0300137808)

During the course of normal operation oils may build inside the primary and secondary chambers of the propane pressure regulator. These oils may be a result of poor fuel quality, contamination of the fuel supply chain, or regional variation in the make up of the fuel. If the build up of the oil is significant this can effect the operation of the fuel control system. Refer to Section 6.3, Operator Maintenance for maintenance intervals. More frequent draining may be required if the fuel supply has been contaminated.

NOTICE

FOR BEST RESULTS WARM THE ENGINE TO OPERATING TEMPERATURE BEFORE DRAINING. THIS WILL ALLOW THE OILS TO FLOW FREELY FROM THE REGULATOR.

1. Move the equipment to a well ventilated area. Ensure there are no external ignition sources.
2. Start the engine and bring to operating temperature.
3. With the engine running, close the manual tank valve and run the engine out of fuel.

4. Push in the Emergency Switch once the engine stops.
5. Disconnect the electrical connection to the LPG fuel temperature sensor in the auxiliary fuel port of the EPR.



6. Remove the retainer clip for the LPG fuel temperature sensor and remove the sensor from the regulator body.

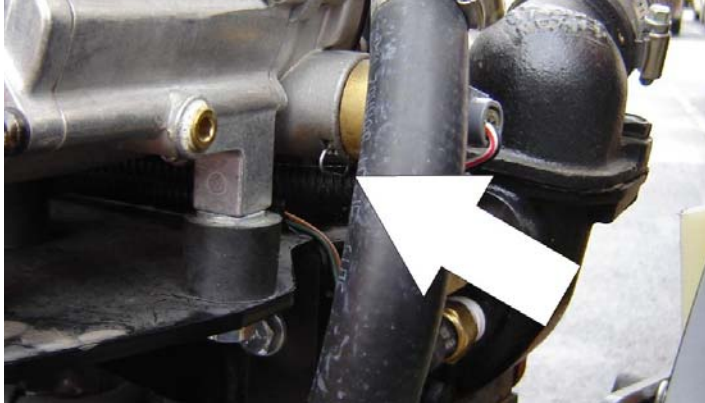

NOTE: Have a small container ready to collect oil that will drain freely from the regulator at this point.

7. Once all of the oil has been drained, reinstall the LPG fuel temperature sensor and reconnect the electrical connector.
8. Open the fuel tank manual valve.
9. Start the engine and verify all connections are secure.
10. Dispose of any drained oil per local regulations in a safe and proper fashion.

6.6 PROPANE FUEL FILTER REPLACEMENT

Removal

1. Relieve the propane fuel system pressure. Refer to Propane Fuel System Pressure Relief.
2. Disconnect the negative battery cable.
3. Slowly loosen the Filter housing and remove it.
4. Pull the filter housing from the Electric lock off assembly.
5. Remove the filter from the housing.
6. Locate Filter magnet and remove it.
7. Remove and discard the housing seal.
8. If equipped, remove and discard the retaining bolt seal.
9. Remove and discard mounting plate to lock off O-ring seal.

SECTION 6 - GENERAL SPECIFICATIONS & OPERATOR MAINTENANCE

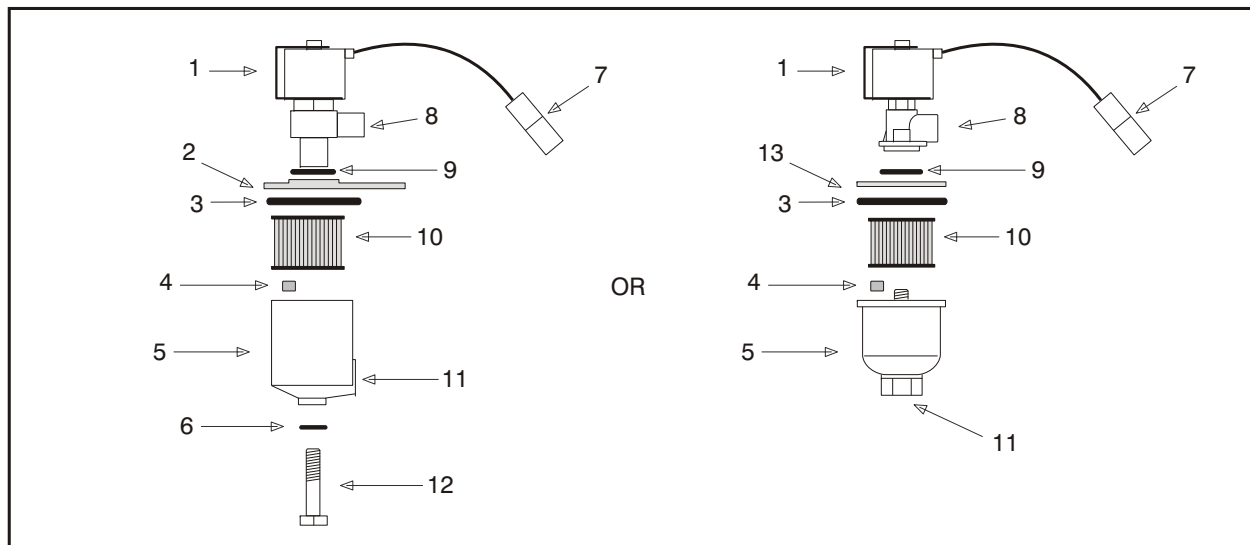

- | | | |
|-------------------------------|-------------------------|--------------------|
| 1. Electric Lock Off Solenoid | 6. Seal | 10. Filter |
| 2. Mounting Plate | 7. Electrical Connector | 11. Fuel Inlet |
| 3. Housing Seal | 8. Fuel Outlet | 12. Retaining Bolt |
| 4. Filter Magnet | 9. O-ring | 13. Ring |
| 5. Filter Housing | | |

Figure 6-13. Filter Lock Assembly

Installation

NOTICE

BE SURE TO REINSTALL THE FILTER MAGNET INTO THE HOUSING BEFORE INSTALLING NEW SEAL

1. Install the mounting plate to lock off O-ring seal.
2. If equipped, install the retaining bolt seal.
3. Install the housing seal.
4. Drop the magnet into the bottom of the filter housing.
5. Install the filter into the housing.
6. If equipped, install the retaining bolt into the filter housing.
7. Install the filter up to the bottom of the electric lock off.
8. Tighten the filter bowl retainer to 106 in lbs (12 Nm).
9. Open manual shut-off valve. Start the vehicle and leak check the propane fuel system at each serviced fitting. Refer to Propane Fuel System Leak Test.

6.7 PROPANE FUEL SYSTEM PRESSURE RELIEF

⚠ CAUTION

THE PROPANE FUEL SYSTEM OPERATES AT PRESSURES UP TO 312 PSI (21.5 BAR). TO MINIMIZE THE RISK OF FIRE AND PERSONAL INJURY, RELIEVE THE PROPANE FUEL SYSTEM PRESSURE (WHERE APPLICABLE) BEFORE SERVICING THE PROPANE FUEL SYSTEM COMPONENTS.

To relieve propane fuel system pressure:

1. Close the manual shut-off valve on the propane fuel tank.
2. Start and run the vehicle until the engine stalls.
3. Turn the ignition switch OFF.

⚠ CAUTION

RESIDUAL VAPOR PRESSURE WILL BE PRESENT IN THE FUEL SYSTEM. ENSURE THE WORK AREA IS WELL VENTILATED BEFORE DISCONNECTING ANY FUEL LINE.

6.8 SUPPLEMENTAL INFORMATION

The following information is provided in accordance with the requirements of the European Machinery Directive 2006/42/EC and is only applicable to CE machines.

For electric powered machines, the equivalent continuous A-Weighted sound pressure level at the work platform is less than 70dB(A)

For combustion engine powered machines, guaranteed Sound Power Level (LWA) per European Directive 2000/14/EC (Noise Emission in the Environment by Equipment for Use Outdoors) based on test methods in accordance with Annex III, Part B, Method 1 and 0 of the directive, is 104 dB.

The vibration total value to which the hand-arm system is subjected does not exceed $2,5 \text{ m/s}^2$. The highest root mean square value of weighted acceleration to which the whole body is subjected does not exceed $0,5 \text{ m/s}^2$.

SECTION 7. INSPECTION AND REPAIR LOG

Machine Serial Number _____

Table 7-1. Inspection and Repair Log

Date	Comments

SECTION 7 - INSPECTION AND REPAIR LOG

Table 7-1. Inspection and Repair Log

Date	Comments



An Oshkosh Corporation Company

TRANSFER OF OWNERSHIP

To Product Owner:

If you now own but **ARE NOT** the original purchaser of the product covered by this manual, we would like to know who you are. For the purpose of receiving safety-related bulletins, it is very important to keep JLG Industries, Inc. updated with the current ownership of all JLG products. JLG maintains owner information for each JLG product and uses this information in cases where owner notification is necessary.

Please use this form to provide JLG with updated information with regard to the current ownership of JLG products. Please return completed form to the JLG Product Safety & Reliability Department via facsimile or mail to address as specified below.

Thank You,
Product Safety & Reliability Department
JLG Industries, Inc.
13224 Fountainhead Plaza
Hagerstown, MD 21742
USA
Telephone: +1-717-485-6591
Fax: +1-301-745-3713

NOTE: Leased or rented units should not be included on this form.

Mfg. Model: _____

Serial Number: _____

Previous Owner: _____

Address: _____

Country: _____ Telephone: (____) _____

Date of Transfer: _____

Current Owner: _____

Address: _____

Country: _____ Telephone: (____) _____

Who in your organization should we notify?

Name: _____

Title: _____



WARNING:



The engine exhaust from this product contains chemicals known to the State of California to cause cancer, birth defects, or other reproductive harm.

1702961

PROPOSITION 65 WARNING

- **Battery posts, terminals and related accessories contain lead and lead compounds, chemicals known to the State of California to cause cancer and reproductive harm.**
- **Batteries also contain other chemicals known to the State of California to cause cancer.**
- **Wash hands after handling.**



An Oshkosh Corporation Company

Corporate Office
JLG Industries, Inc.
1 JLG Drive
McConnellsburg PA. 17233-9533
USA

(717) 485-5161

(717) 485-6417



3121179

JLG Worldwide Locations

JLG Industries (Australia)
P.O. Box 5119
11 Bolwarra Road
Port Macquarie
N.S.W. 2444
Australia

+61 2 65 811111

+61 2 65813058

JLG Latino Americana Ltda.
Rua Eng. Carlos Stevenson,
80-Suite 71
13092-310 Campinas-SP
Brazil

+55 19 3295 0407

+55 19 3295 1025

JLG Industries (UK) Ltd
Bentley House
Bentley Avenue
Middleton
Greater Manchester
M24 2GP - England

+44 (0)161 654 1000

+44 (0)161 654 1001

JLG France SAS
Z.I. de Baulieu
47400 Fauillet
France

+33 (0)5 53 88 31 70

+33 (0)5 53 88 31 79

JLG Deutschland GmbH
Max-Planck-Str. 21
D - 27721 Ritterhude - Ihlpohl
Germany

+49 (0)421 69 350 20

+49 (0)421 69 350 45

JLG Equipment Services Ltd.
Rm 1107 Landmark North
39 Lung Sum Avenue
Sheung Shui N. T.
Hong Kong

(852) 2639 5783

(852) 2639 5797

JLG Industries (Italia) s.r.l.
Via Po. 22
20010 Pregnana Milanese - MI
Italy

+39 029 359 5210

+39 029 359 5845

Oshkosh-JLG Singapore Technology
Equipment Pte Ltd
29 Tuas Ave 4,
Jurong Industrial Estate
Singapore, 639379

+65-6591 9030

+65-6591 9031

Plataformas Elevadoras
JLG Iberica, S.L.
Trapadella, 2
P.I. Castellbisbal Sur
08755 Castellbisbal, Barcelona
Spain

+34 93 772 4700

+34 93 771 1762

JLG Sverige AB
Enkopingsvagen 150
Box 704
SE - 176 27 Jarfalla
Sweden

+46 (0)850 659 500

+46 (0)850 659 534