

## Standard Features

- 20.3 m (66 ft) working height
- 10.4 m (34 ft) horizontal reach
- 227 kg (500 lb) lift capacity
- Tier II emission capable engine
- Diesel engine or dual fuel option (petrol/LPG)
- Fully proportional platform controls with ramp up/down feature
- Hydraulic platform rotation
- 360° continuous turntable rotation
- 12V DC auxiliary power unit
- Fuel select switch on platform and ground controls (Petrol/LPG models)
- Closed-loop hydrostatic drive
- Positive traction drive
- Drive enable system

- Full time 4 wheel drive (on 4WD models)
- Hall effect joystick controllers
- Full time active oscillating axle
- Self-leveling platform
- Locking turntable covers
- Anti-restart engine protection
- Auto engine fault shutdown
- AC wiring to platform
- Tilt alarm
- Horn
- Hour meter
- Foot switch time-out

## Options and Accessories

- Alarm package
- Cold start packages
- 5000 watt AC generators
- 1.83m (6 ft) steel platform
- Platform swing gate
- Air line to platform
- Platform rail pinch guard
- Platform work lights
- Lockable platform control box cover
- Tool tray
- Fluorescent tube caddy
- Hostile environment packages
- GS/LPS rating for Ford engine-powered machines
- Engine monitoring gauges
- Tow package (4x2 models only)
- Driving lights

## Range of Motion

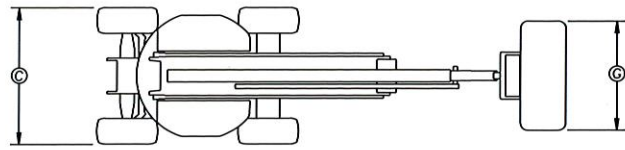
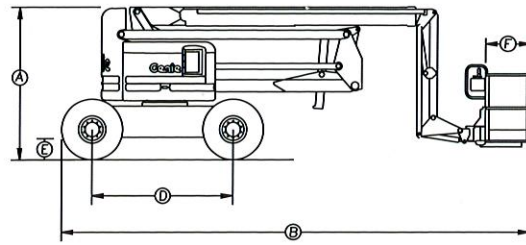
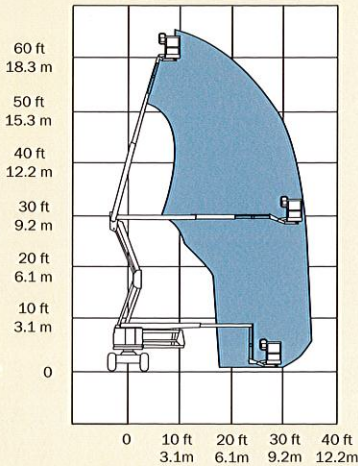

## Specifications

Model	4x2/4x4	Metric	US
Working height max*		20.3 m	66 ft
Platform height max		18.3 m	60 ft
(A) Height - stowed		2.64 m	8 ft 8 in
(B) Length - stowed		7.9 m	26 ft
(C) Width		2.41 m	7 ft 11 in
(D) Wheelbase		2.54 m	8 ft 4 in
(E) Ground clearance		40 cm	16 in
(F) Platform length: 6 ft		76 cm	30 in
8 ft		91 cm	36 in
(G) Platform width: 6 ft		1.83 m	72 in
8 ft		2.44 m	96 in
Horizontal reach max		10.4 m	34 ft
Up and over clearance		8.23 m	27 ft
Lift capacity		227 kg	500 lb
Turning radius - outside		4.1 m	13.5 ft
Turning radius - inside		1.2 m	4 ft
Turntable rotation		360° continuous	
Tailswing		zero	
Power source		Deutz Diesel F3L 2011 48 hp (35.8 kW)	
		Ford LRG-425 petrol EFI 82 hp (61.1 kW)	
		Perkins 404C-22 diesel 51hp (38 kW)	
Drive speed - stowed		6.4 km/h	4.0 mph
Drive speed - raised <sup>1</sup>		1 km/h	0.6 mph
Controls		12V DC proportional	
Platform rotation		180°	180°
Auxiliary power unit		12V DC	
Tyres		15x19.5, 12 ply	
Gradeability <sup>2</sup> 2 WD		25%	25%
4 WD		40%	40%
Hydraulic tank capacity		170 litre	45 gal
Fuel tank capacity		125 litre	33 gal
Weight**		9,929 kg	22,055 lb

1 In lift mode (platform raised), the machine is designed for operation on firm level surfaces only.  
2 Stowed position only.

\* The metric equivalent of working height adds 2 m to platform height. U.S. adds 6 ft to platform height.  
\*\* Weight will vary depending on options and/or country standards.

## Standards Compliance

- CE EN280
- AS1418-10

Distributed By:

**Genie**  
A TEREX COMPANY

**GENIE AUSTRALIA**  
591 Boundary Road, Darra, QLD 4076  
PO BOX 394, Richlands, QLD 4077  
Telephone **07 3375 1660**  
Toll Free in Australia **1800 331 660**  
Fax 07 3375 1002  
<http://www.genieindustries.com>

**GENIE UNITED STATES**  
18340 NE 76th Street  
P. O. Box 97030  
Redmond, Washington 98073-9730  
Telephone **+1 (425) 881-1800**  
Fax +1 (425) 883-3475  
<http://www.genieindustries.com>