



# ***Operator's Manual***

***Z-34/22***  
***Z-34/22N***  
***DC Power***

with  
Maintenance  
Information

Original Instructions  
Sixth Edition  
First Printing  
Part No. 1258814

---

## Important

Read, understand and obey these safety rules and operating instructions before operating this machine. Only trained and authorized personnel shall be permitted to operate this machine. This manual should be considered a permanent part of your machine and should remain with the machine at all times. If you have any questions, call Genie.

---

## Contents

	Page
Safety Rules .....	1
Controls .....	10
Legend .....	12
Pre-operation Inspection .....	13
Maintenance .....	15
Function Tests .....	18
Workplace Inspection .....	23
Operating Instructions .....	24
Transport and Lifting Instructions .....	31
Decals .....	34
Specifications .....	38

---

## Contact us:

Internet: <http://www.genielift.com>  
 e-mail: [awp.techpub@terex.com](mailto:awp.techpub@terex.com)

---

Copyright © 1996 by Genie Industries

Sixth Edition: First Printing, July 2014

"Genie" and "Z" are registered trademarks of Genie Industries in the U.S.A. and many other countries.

These machines comply with  
 ANSI A92.5  
 CSA B354.4

 Complies with EC Directive 2006/42/EC  
 See EC Declaration of Conformity

 Printed on recycled paper

Printed in U.S.A.

# Safety Rules



---

## Danger

Failure to obey the instructions and safety rules in this manual will result in death or serious injury.

---

## Do Not Operate Unless:

- You learn and practice the principles of safe machine operation contained in this operator's manual.

### 1 Avoid hazardous situations.

**Know and understand the safety rules before going on to the next section.**

- 2 Always perform a pre-operation inspection.
- 3 Always perform function tests prior to use.
- 4 Inspect the workplace.
- 5 Only use the machine as it was intended.

- You read, understand and obey the manufacturer's instructions and safety rules—safety and operator's manuals and machine decals.
- You read, understand and obey employer's safety rules and worksite regulations.
- You read, understand and obey all applicable governmental regulations.
- You are properly trained to safely operate the machine.

SAFETY RULES

### Electrocution Hazards

This machine is not electrically insulated and will not provide protection from contact with or proximity to electrical current.

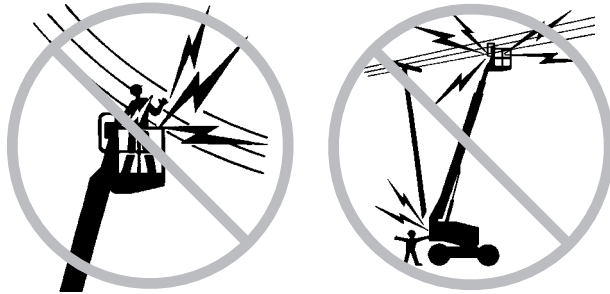

Maintain safe distances from electrical power lines and apparatus in accordance with applicable governmental regulations and the following chart.

Voltage Phase to Phase	Minimum Safe Approach Distance	
	Feet	Meters
0 to 300V	Avoid Contact	
300V to 50KV	10	3.05
50KV to 200KV	15	4.60
200KV to 350KV	20	6.10
350KV to 500KV	25	7.62
500KV to 750KV	35	10.67
750KV to 1000KV	45	13.72

Allow for platform movement, electrical line sway or sag and beware of strong or gusty winds.

Keep away from the machine if it contacts energized power lines. Personnel on the ground or in the platform must not touch or operate the machine until energized power lines are shut off.

Do not operate the machine during lightning or storms.

Do not use the machine as a ground for welding.

### Tip-over Hazards

Occupants, equipment and materials shall not exceed the maximum platform capacity.

Maximum platform capacity	500 lbs	227 kg
<b>Maximum platform capacity</b>		
Machine equipped with Aircraft Protection Package	440 lbs	200 kg
<b>Maximum occupants</b>	2	

The weight of options and accessories, such as pipe cradles, panel cradles and welders, will reduce the rated platform capacity and must be factored into the total platform load. See the decals on the options.

## SAFETY RULES

**CE and Australia Markets:** Do not use air-filled tires. These machines are equipped with foam-filled tires. Wheel weight and proper counterweight configuration are critical to stability.

Do not raise or extend the boom unless the machine is on a firm, level surface.

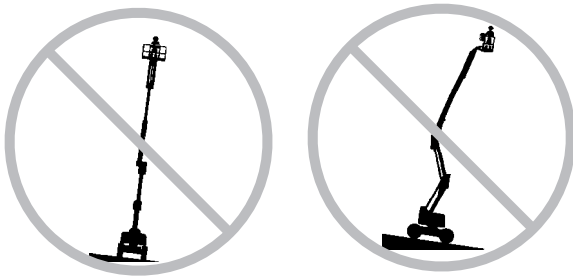

Do not depend on the tilt alarm as a level indicator. The tilt alarm sounds in the platform only when the machine is on a severe slope.

If the tilt alarm sounds while the boom is lowered: Do not extend, rotate or raise the boom above horizontal. Move the machine to a firm, level surface before raising the platform.

**ANSI, CSA and AUS models:** If the tilt alarm sounds when the platform is raised: Use extreme caution. Identify the condition of the boom on the slope as shown below. Follow the steps to lower the boom before moving to a firm, level surface. Do not rotate the boom while lowering.

**CE models:** If the tilt alarm sounds when the platform is raised, use extreme caution. The Machine Not Level indicator light will come on and the drive function in one or both directions will not operate. Identify the condition of the boom on the slope as shown below. Follow the steps to lower the boom before moving to a firm, level surface. Do not rotate the boom while lowering.

**All models:** If the tilt alarm sounds with the platform uphill:

- 1 Lower the primary boom.
- 2 Lower the secondary boom.
- 3 Retract the primary boom.

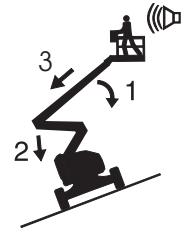

If the tilt alarm sounds with the platform downhill:

- 1 Retract the primary boom.
- 2 Lower the secondary boom.
- 3 Lower the primary boom.

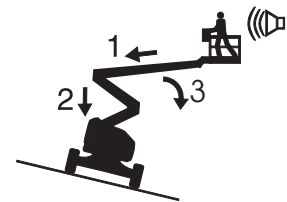

**SAFETY RULES**

Do not alter or disable the limit switches.

Do not drive over 0.7 mph / 1 km/h with the primary boom raised or extended or the secondary boom raised.

Do not use the platform controls to free a platform that is caught, snagged or otherwise prevented from normal motion by an adjacent structure. All personnel must be removed from the platform before attempting to free the platform using the ground controls.

Do not raise the boom when wind speeds may exceed 28 mph / 12.5 m/s. If wind speeds exceed 28 mph / 12.5 m/s when the boom is raised, lower the boom and do not continue to operate the machine.

Do not operate the machine in strong or gusty winds. Do not increase the surface area of the platform or the load. Increasing the area exposed to the wind will decrease machine stability.



Use extreme care and slow speeds while driving the machine in the stowed position across uneven terrain, debris, unstable or slippery surfaces and near holes and drop-offs.

Do not drive the machine on or near uneven terrain, unstable surfaces or other hazardous conditions with the boom raised or extended.

Do not drive the machine on a slope that exceeds the maximum uphill, downhill or side slope rating of the machine. Slope rating applies only to machines in the stowed position.

**Z-34/22N, Maximum slope rating, stowed position**

Counterweight uphill	35%	19°
Counterweight downhill	20%	11°
Side slope	25%	14°

**Z-34/22 DC, Maximum slope rating, stowed position**

Counterweight uphill	30%	17°
Counterweight downhill	20%	11°
Side slope	25%	14°

Note: Slope rating is subject to ground conditions and adequate traction.

Do not push off or pull toward any object outside of the platform.

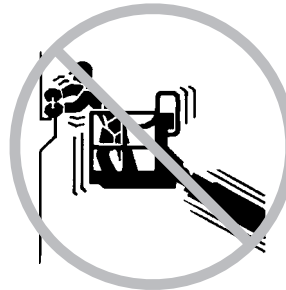

**Maximum allowable side force - ANSI & CSA**

150 lbs / 667 N

**Maximum allowable manual force - CE**

90 lbs / 400 N

## SAFETY RULES

Do not alter or disable machine components that in any way affect safety and stability.

Do not replace items critical to machine stability with items of different weight or specification.

Do not modify or alter an aerial work platform without prior written permission from the manufacturer. Mounting attachments for holding tools or other materials onto the platform, toeboards or guard rail system can increase the weight in the platform and the surface area of the platform or the load.

Do not place or attach overhanging loads to any part of this machine.

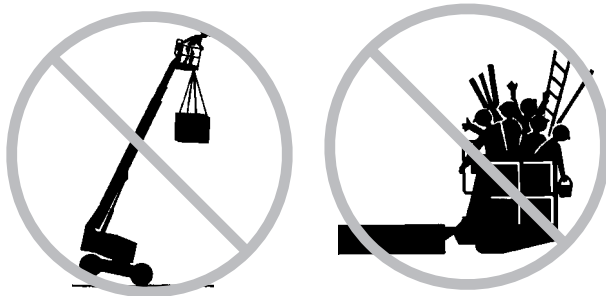

Do not place ladders or scaffolds in the platform or against any part of this machine.

Do not transport tools and materials unless they are evenly distributed and can be safely handled by person(s) in the platform.

Do not use the machine on a moving or mobile surface or vehicle.

Be sure all tires are in good condition and lug nuts are properly tightened.

Do not use batteries that weigh less than the original equipment. Batteries are used as counterweight and are critical to machine stability. Each battery must weigh a minimum of 88 lbs / 40 kg. Each battery box including batteries must weigh a minimum of 452 lbs / 205 kg.

Do not use the machine as a crane.

Do not push the machine or other objects with the boom.

Do not contact adjacent structures with the boom.

Do not tie the boom or platform to adjacent structures.

Do not place loads outside the platform perimeter.

**SAFETY RULES**

**Fall Hazards**

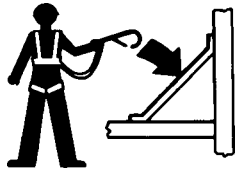

Occupants must wear a safety belt or harness and comply with applicable governmental regulations. Attach lanyard to the anchor provided in the platform.

Do not sit, stand or climb on the platform guard rails. Maintain a firm footing on the platform floor at all times.

Do not climb down from the platform when raised.

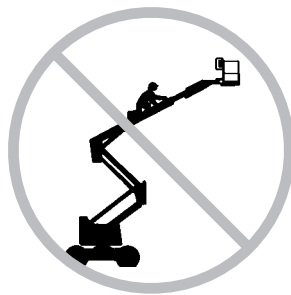

Keep the platform floor clear of debris.

Lower the platform entry mid-rail or close the entry gate before operating.

Do not enter or exit the platform unless the machine is in the stowed position and the platform is at ground level.

**Collision Hazards**

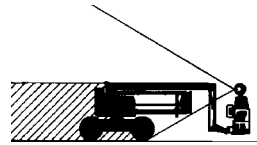

Be aware of limited sight distance and blind spots when driving or operating.

Be aware of the boom position when rotating the turntable.

Check the work area for overhead obstructions or other possible hazards.



Be aware of crushing hazards when grasping the platform guard rail.

Operators must comply with employer, job site and governmental rules regarding the use of personal protective equipment.

Observe and use the color-coded direction arrows on the platform controls and drive chassis for drive and steer functions.



## SAFETY RULES

Do not lower the boom unless the area below is clear of personnel and obstructions.

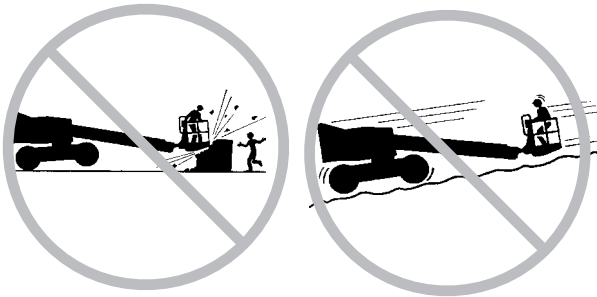

Limit travel speed according to the condition of the ground surface, congestion, slope, location of personnel, and any other factors which may cause collision.

Do not operate a boom in the path of any crane unless the controls of the crane have been locked out and/or precautions have been taken to prevent any potential collision.

No stunt driving or horseplay while operating a machine.

## Component Damage Hazard

Do not use the machine as a ground for welding.

## Damaged Machine Hazards

Do not use a damaged or malfunctioning machine.

Conduct a thorough pre-operation inspection of the machine and test all functions before each work shift. Immediately tag and remove from service a damaged or malfunctioning machine.

Be sure all maintenance has been performed as specified in this manual and the *Genie Z-34/22 & Genie Z-34/22N Service Manual*.

Be sure all decals are in place and legible.

Be sure the operator's, safety and responsibilities manuals are complete, legible and in the storage container located on the platform.

## SAFETY RULES

**Bodily Injury Hazard**

Do not operate the machine with a hydraulic oil or air leak. An air leak or hydraulic leak can penetrate and/or burn skin.

Improper contact with components under any cover will cause serious injury. Only trained maintenance personnel should access compartments. Access by the operator is only advised when performing a pre-operation inspection. All compartments must remain closed and secured during operation.

**Decal Legend**

Genie product decals use symbols, color coding and signal words to identify the following:



Safety alert symbol—used to alert personnel to potential personal injury hazards. Obey all safety messages that follow this symbol to avoid possible injury or death.

**▲ DANGER**



Red—used to indicate the presence of an imminently hazardous situation which, if not avoided, will result in death or serious injury.

**▲ WARNING**



Orange—used to indicate the presence of a potentially hazardous situation which, if not avoided, could result in death or serious injury.

**▲ CAUTION**



Yellow with safety alert symbol—used to indicate the presence of a potentially hazardous situation which, if not avoided, may cause minor or moderate injury.

**CAUTION**

Yellow without safety alert symbol—used to indicate the presence of a potentially hazardous situation which, if not avoided, may result in property damage.

**NOTICE**

Green—used to indicate operation or maintenance information.

## SAFETY RULES

## Battery Safety

### Burn Hazards

Batteries contain acid. Always wear protective clothing and eye wear when working with batteries.

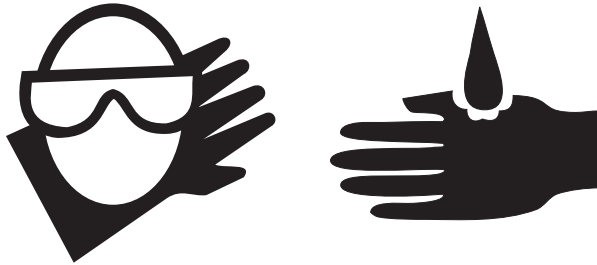

Avoid spilling or contacting battery acid. Neutralize battery acid spills with baking soda and water.

The battery pack must remain in upright position.

Do not expose the batteries or the charger to water or rain.

### Explosion Hazards



Keep sparks, flames and lighted tobacco away from batteries. Batteries emit an explosive gas.

The battery pack cover must remain off during the entire charging cycle.

Do not contact the battery terminals or the cable clamps with tools that may cause sparks.

### Component Damage Hazards

Do not use any battery charger greater than 48V to charge the batteries.

Both battery packs must be charged together.

Disconnect the battery pack plug before removing the battery pack.

### Electrocution Hazards



Connect the battery charger to a grounded, AC 3-wire electrical outlet only.

Inspect daily for damaged cord, cables and wires. Replace damaged items before operating.

Avoid electrical shock from contact with battery terminals. Remove all rings, watches and other jewelry.

### Tip-over Hazard

Do not use batteries that weigh less than the original equipment. Batteries are used as counterweight and are critical to machine stability. Each battery must weigh a minimum of 88 lbs / 40 kg. Each battery box including batteries must weigh a minimum of 452 lbs / 205 kg.

### Lifting Hazard

Use a forklift to remove or install the battery packs.

# Controls

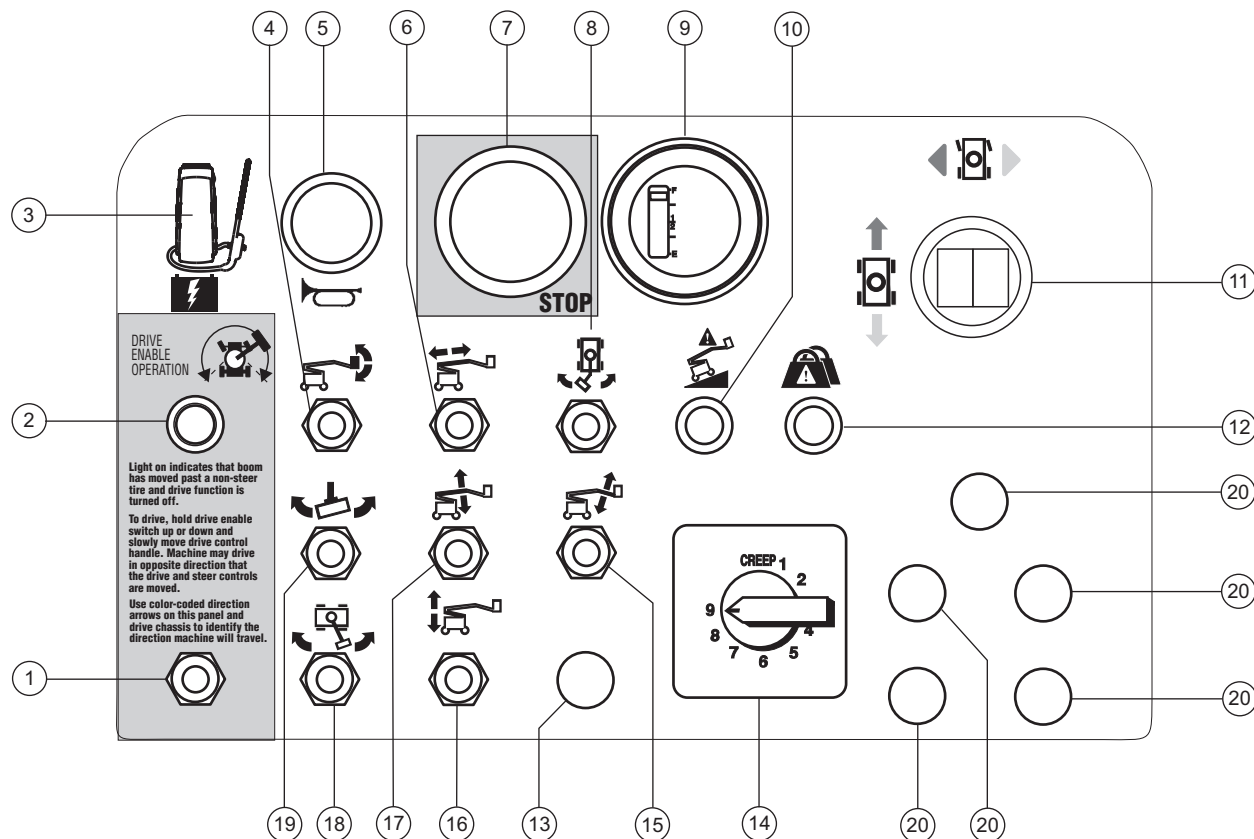

## Platform Control Panel

- |   |   |
|---|---|
| 1 Drive enable switch   | 10 Machine not level indicator light (if equipped)                                    |
| 2 Drive enable indicator light  | 11 Proportional control handle for drive function and thumb rocker for steer function |
| 3 ANSI/CSA models:Auxiliary power switch<br>CE models:Auxiliary power switch with cover | 12 Platform overload indicator light (if equipped)                                    |
| 4 Platform level switch   | 13 Boom function speed controller   |
| 5 Horn button   | 14 Jib boom up/down switch  |
| 6 Primary boom extend/retract switch  | 15 Secondary boom up/down switch  |
| 7 Red Emergency Stop button   | 16 Primary boom up/down switch  |
| 8 Function override - Aircraft protection package (if equipped)                         | 17 Turntable rotate switch  |
| 9 Battery charge indicator and/or low voltage interrupt (option)                        | 18 Platform rotate switch   |
|   | 19 Not used   |

CONTROLS

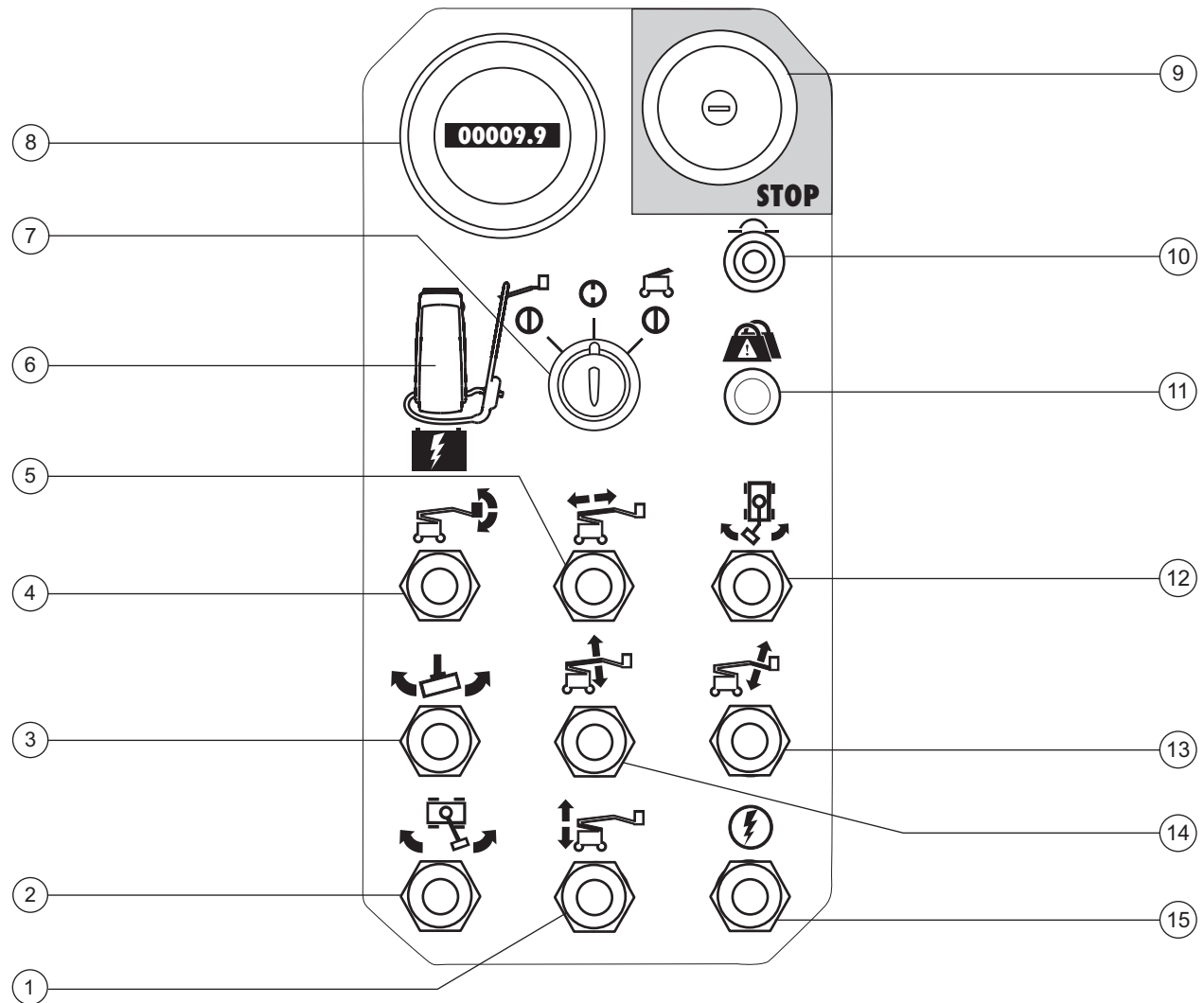

**Ground Control Panel**

- |   |  |
|---|--|
| 1 Secondary boom up/down switch   | 8 Hour meter                                       |
| 2 Turntable rotate switch   | 9 Red Emergency Stop button                        |
| 3 Platform rotate switch  | 10 10A breaker for electrical circuits             |
| 4 Platform level switch   | 11 Platform overload indicator light (if equipped) |
| 5 Primary boom extend/retract switch  | 12 Not used  |
| 6 ANSI/CSA models:Auxiliary power switch<br>CE models:Auxiliary power switch with cover | 13 Jib boom up/down switch                         |
| 7 Key switch for platform/off/ground selection  | 14 Primary boom up/down switch                     |
|   | 15 Function enable switch                          |



# Legend

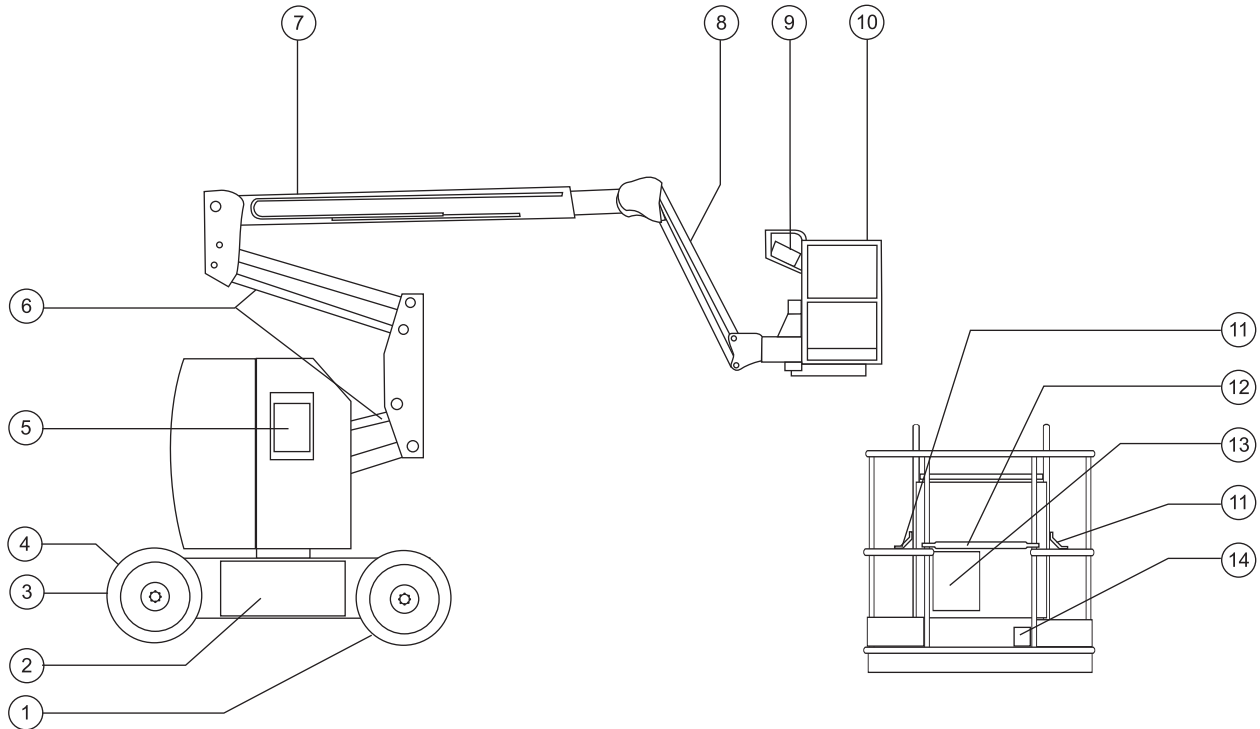

- |  |                             |
|--|-----------------------------|
| 1 Non-steer tire                         | 9 Platform controls         |
| 2 Battery box                            | 10 Platform                 |
| 3 Steer tire                             | 11 Lanyard anchorage point  |
| 4 Power to charger (between steer tires) | 12 Sliding mid-rail         |
| 5 Ground controls                        | 13 Manual storage container |
| 6 Secondary boom                         | 14 Foot switch              |
| 7 Primary boom                           |                             |
| 8 Jib boom                               |                             |

# Pre-operation Inspection



## Do Not Operate Unless:

- You learn and practice the principles of safe machine operation contained in this operator's manual.

1 Avoid hazardous situations.

### 2 Always perform a pre-operation inspection.

**Know and understand the pre-operation inspection before going on to the next section.**

3 Always perform function tests prior to use.

4 Inspect the workplace.

5 Only use the machine as it was intended.

## Fundamentals

It is the responsibility of the operator to perform a pre-operation inspection and routine maintenance.

The pre-operation inspection is a visual inspection performed by the operator prior to each work shift. The inspection is designed to discover if anything is apparently wrong with a machine before the operator performs the function tests.

The pre-operation inspection also serves to determine if routine maintenance procedures are required. Only routine maintenance items specified in this manual may be performed by the operator.

Refer to the list on the next page and check each of the items.

If damage or any unauthorized variation from factory delivered condition is discovered, the machine must be tagged and removed from service.

Repairs to the machine may only be made by a qualified service technician, according to the manufacturer's specifications. After repairs are completed, the operator must perform a pre-operation inspection again before going on to the function tests.

Scheduled maintenance inspections shall be performed by qualified service technicians, according to the manufacturer's specifications and the requirements listed in the responsibilities manual.

## PRE-OPERATION INSPECTION

## Pre-operation Inspection

---

- Be sure that the operator's, safety and responsibilities manuals are complete, legible and in the storage container located on the platform.
- Be sure that all decals are legible and in place. See Decals section.
- Check for hydraulic oil leaks and proper oil level. Add oil if needed. See Maintenance section.
- Check for battery fluid leaks and proper fluid level. Add distilled water if needed. See Maintenance section.
- Z-34/22: Check for proper tire pressure. Add air if needed. See Maintenance section.

Check the following components or areas for damage, improperly installed or missing parts and unauthorized modifications:

- Electrical components, wiring and electrical cables
- Hydraulic power unit, tank, hoses, fittings, cylinders and manifolds
- Drive and turntable motors and drive hubs
- Boom wear pads
- Tires and wheels
- Limit switches, alarms and horn
- Nuts, bolts and other fasteners
- Platform entry mid-rail bar or gate
- Beacon and alarms (if equipped)
- Lanyard anchorage points

Check entire machine for:

- Cracks in welds or structural components
- Dents or damage to machine
- Be sure that all structural and other critical components are present and all associated fasteners and pins are in place and properly tightened.
- Be sure that both battery packs are in place, latched and properly connected.
- After you complete your inspection, be sure that all compartment covers are in place and latched.



# Maintenance



## Observe and Obey:

- ☑ Only routine maintenance items specified in this manual shall be performed by the operator.
- ☑ Scheduled maintenance inspections shall be completed by qualified service technicians, according to the manufacturer's specifications and the requirements specified in the responsibilities manual.
- ☑ Dispose of material in accordance with governmental regulations.

## Maintenance Symbols Legend

### NOTICE

The following symbols have been used in this manual to help communicate the intent of the instructions. When one or more of the symbols appear at the beginning of a maintenance procedure, it conveys the meaning below.



Indicates that tools will be required to perform this procedure.



Indicates that new parts will be required to perform this procedure.

## Check the Hydraulic Oil Level



Maintaining the hydraulic oil at the proper level is essential to machine operation. Improper hydraulic oil levels can damage hydraulic components. Daily checks allow the inspector to identify changes in oil level that might indicate the presence of hydraulic system problems.

- 1 Be sure that the boom is in the stowed position.
- 2 Check the hydraulic oil level.
- ⊙ Result: The hydraulic oil level should be, between the **FULL** and **ADD** marks on the hydraulic tank.
- 3 Add hydraulic oil if necessary.

---

### Hydraulic Oil Specifications

---

Hydraulic oil type	Chevron Rando HD Premium MV equivalent
--------------------	---

---

## MAINTENANCE

## Check the Batteries



Proper battery condition is essential to good machine performance and operational safety. Improper fluid levels or damaged cables and connections can result in component damage and hazardous conditions.

**⚠ WARNING** Electrocuting/burn hazard. Contact with hot or live circuits could result in death or serious injury. Remove all rings, watches and other jewelry.

**⚠ WARNING** Bodily injury hazard. Batteries contain acid. Avoid spilling or contacting battery acid. Neutralize battery acid spills with baking soda and water.

**NOTICE** Perform this test after fully charging the batteries.

- 1 Put on protective clothing and eye wear.
- 2 Be sure that the battery cable connections are tight and free of corrosion.

### Standard Batteries

- 3 Remove the battery vent caps.
- 4 Check the battery acid level. If necessary, replenish with distilled water to the bottom of the battery fill tube. Do not overfill.
- 5 Install the vent caps.

## Check the Tire Pressure



**NOTICE** This procedure does not need to be performed on machines equipped with the foam-filled or solid tires.

**⚠ WARNING** Bodily injury hazard. An over-inflated tire can explode and may cause death or serious injury.

**⚠ WARNING** Tip-over hazard. Do not use temporary flat tire repair products.

To safeguard maximum stability, achieve optimum machine handling and minimize tire wear, it is essential to maintain proper pressure in all air-filled tires.

- 1 Check each tire with an air pressure gauge and add air as needed.

### Tire pressure

Industrial tire	100 psi	6.89 bar
-----------------	---------	----------

## MAINTENANCE

## Scheduled Maintenance

Maintenance performed quarterly, annually and every two years must be completed by a person trained and qualified to perform maintenance on this machine according to the procedures found in the service manual for this machine.

Machines that have been out of service for more than three months must receive the quarterly inspection before they are put back into service.

# Function Tests



## Do Not Operate Unless:

- ☑ You learn and practice the principles of safe machine operation contained in this operator's manual.

1 Avoid hazardous situations.

2 Always perform a pre-operation inspection.

**3 Always perform function tests prior to use.**

**Know and understand the function tests before going on to the next section.**

4 Inspect the workplace.

5 Only use the machine as it was intended.

## Fundamentals

The function tests are designed to discover any malfunctions before the machine is put into service. The operator must follow the step-by-step instructions to test all machine functions.

A malfunctioning machine must never be used. If malfunctions are discovered, the machine must be tagged and removed from service. Repairs to the machine may only be made by a qualified service technician, according to the manufacturer's specifications.

After repairs are completed, the operator must perform a pre-operation inspection and function tests again before putting the machine into service.

- 1 Select a test area that is firm, level and free of obstruction.

## At the Ground Controls

2 Turn the key switch to ground control.

3 Pull out the red Emergency Stop button to the on position.

- ⦿ Result: The beacon (if equipped) should flash.

### Test Emergency Stop

4 Push in the red Emergency Stop button to the off position.

- ⦿ Result: All ground and platform control functions should not operate.

5 Pull out the red Emergency Stop button to the on position.

## FUNCTION TESTS

**Test the Boom Functions**

- 6 Do not hold the function enable switch to either side. Attempt to activate each boom and platform function toggle switch.



- ⦿ Result: All boom and platform functions should not operate.
- 7 Hold the function enable switch to either side and activate each boom and platform function toggle switch.
- ⦿ Result: All boom and platform functions should operate through a full cycle. The descent alarm (if equipped) should sound while the boom is lowering.

**Test the Tilt Sensor**

- 8 Pull out the platform red Emergency Stop button to the on position. Turn the key switch to platform control.
- 9 Open the ground control side turntable cover and locate the tilt sensor next to the function manifold.
- 10 Press down one side of the tilt sensor.
- ⦿ Result: The alarm, located in the platform, should sound.

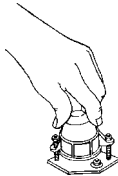
**At the Platform Controls**

- 11 Turn the key switch to platform control.
- 12 Pull out the red Emergency Stop button to the on position.

- ⦿ Result: The beacon (if equipped) should flash.

**Test Emergency Stop**

- 13 Push in the platform red Emergency Stop button to the off position.

- ⦿ Result: All platform control functions should not operate.

---

## FUNCTION TESTS

### Test the Horn

- 14 Pull out the red Emergency Stop button to the on position.
- 15 Push the horn button.
- ⦿ Result: The horn should sound.

### Test the Foot Switch

- 16 Do not press down the foot switch. Activate each machine function.
- ⦿ Result: The machine functions should not operate.

### Test Machine Functions

- 17 Press down the foot switch.
- 18 Activate each machine function toggle switch.
- ⦿ Result: All boom and platform functions should operate through a full cycle.

Note: Control the speed of boom functions by adjusting the boom function speed controller. Drive and steer functions are not affected by the boom function speed controller.

### Test the Steering

- 19 Press down the foot switch.
- 20 Depress the thumb rocker switch on top of the drive control handle in the direction identified by the blue triangle on the control panel.
- ⦿ Result: The steer wheels should turn in the direction that the blue triangles point on the drive chassis.
- 21 Depress the thumb rocker switch in the direction identified by the yellow triangle on the control panel.
- ⦿ Result: The steer wheels should turn in the direction that the yellow triangles point on the drive chassis.

## FUNCTION TESTS

**Test Drive and Braking**

- 22 Press down the foot switch.
- 23 Slowly move the drive control handle in the direction indicated by the blue arrow on the control panel until the machine begins to move, then return the handle to the center position.
- ⦿ Result: The travel alarm should sound. The machine should move in the direction that the blue arrow points on the drive chassis, then come to an abrupt stop.
- 24 Slowly move the drive control handle in the direction indicated by the yellow arrow on the control panel until the machine begins to move, then return the handle to the center position.
- ⦿ Result: The travel alarm should sound. The machine should move in the direction that the yellow arrow points on the drive chassis, then come to an abrupt stop.

Note: The brakes must be able to hold the machine on any slope it is able to climb.

**Test Limited Drive Speed**

- 25 Press down the foot switch.
- 26 Raise the primary boom 1 foot / 30 cm.
- 27 Slowly move the drive control handle to the full drive position.
- ⦿ Result: The maximum achievable drive speed with the primary boom raised should not exceed 1 foot / 30 cm per second.
- 28 Lower the boom to the stowed position.
- 29 Raise the secondary boom 1 foot / 30 cm.
- 30 Slowly move the drive control handle to the full drive position.
- ⦿ Result: The maximum achievable drive speed with the secondary boom raised should not exceed 1 foot / 30 cm per second.
- 31 Lower the boom to the stowed position.
- 32 Extend the primary boom 1 foot / 30 cm.
- 33 Slowly move the drive control handle to the full drive position.
- ⦿ Result: The maximum achievable drive speed with the primary boom extended should not exceed 1 foot / 30 cm per second.

If the drive speed with the primary boom raised or extended or the secondary boom raised exceeds 1 foot / 30 cm per second, immediately tag and remove the machine from service.

## FUNCTION TESTS

**Test the Drive Enable System**

- 34 Press down the foot switch and retract the primary boom to the stowed position.
- 35 Rotate the turntable until the boom moves past one of the non-steer wheels.

- ⦿ Result: The drive enable indicator light should come on and remain on while the boom is anywhere in the range shown.

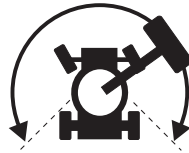

- 36 Move the drive control handle off center.

- ⦿ Result: The drive function should not operate.

- 37 Hold the drive enable toggle switch up or down and slowly move the drive control handle off center.

- ⦿ Result: The drive function should operate.

Note: When the drive enable system is in use, the machine may drive in the opposite direction that the drive and steer control handle is moved.

Use the color-coded direction arrows on the platform controls and the drive chassis to identify the direction of travel.

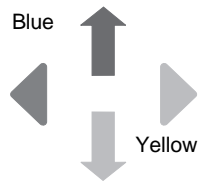
**Test the Lift/Drive Select Function (if equipped)**

- 38 Press down the foot switch.
- 39 Move the drive control handle off center and activate a boom function toggle switch.
- ⦿ Result: No boom functions should operate. The machine will move in the direction indicated on the control panel.



# Workplace Inspection



## Do Not Operate Unless:

- You learn and practice the principles of safe machine operation contained in this operator's manual.

- 1 Avoid hazardous situations.
- 2 Always perform a pre-operation inspection.
- 3 Always perform function tests prior to use.

### 4 Inspect the workplace.

**Know and understand the workplace inspection before going on to the next section.**

- 5 Only use the machine as it was intended.

## Workplace Inspection

Be aware of and avoid the following hazardous situations:

- drop-offs or holes
- bumps, floor obstructions or debris
- sloped surfaces
- unstable or slippery surfaces
- overhead obstructions and high voltage conductors
- hazardous locations
- inadequate surface support to withstand all load forces imposed by the machine
- wind and weather conditions
- the presence of unauthorized personnel
- other possible unsafe conditions

## Fundamentals

The workplace inspection helps the operator determine if the workplace is suitable for safe machine operation. It should be performed by the operator prior to moving the machine to the workplace.

It is the operator's responsibility to read and remember the workplace hazards, then watch for and avoid them while moving, setting up and operating the machine.

# Operating Instructions



---

## Do Not Operate Unless:

- You learn and practice the principles of safe machine operation contained in this operator's manual.
  - 1 Avoid hazardous situations.
  - 2 Always perform a pre-operation inspection.
  - 3 Always perform function tests prior to use.
  - 4 Inspect the workplace.
  - 5 Only use the machine as it was intended.**

## Fundamentals

The Operating Instructions section provides instructions for each aspect of machine operation. It is the operator's responsibility to follow all the safety rules and instructions in the operator's, safety and responsibilities manuals.

Using the machine for anything other than lifting personnel, along with their tools and materials, to an aerial work site is unsafe and dangerous.

Only trained and authorized personnel should be permitted to operate a machine. If more than one operator is expected to use a machine at different times in the same work shift, they must all be qualified operators and are all expected to follow all safety rules and instructions in the operator's, safety and responsibilities manuals. That means every new operator should perform a pre-operation inspection, function tests, and a workplace inspection before using the machine.

## OPERATING INSTRUCTIONS

## Emergency Stop

Push in the red Emergency Stop button to the off position at the ground or platform controls to stop all machine functions.

Repair any function that operates when the red Emergency Stop button is pushed in.

Selecting and operating the ground controls will override the platform Red Emergency Stop button.

## Auxiliary Controls

Use auxiliary power if the primary power source fails.

- 1 Be sure that both battery packs are connected before operating the machine.
- 2 Turn the key switch to ground or platform control.
- 3 Pull out the red Emergency Stop button to the on position.
- 4 Press down the foot switch when operating the auxiliary controls from the platform.
- 5 CE models: Break the security tie and lift the cover.

Note: If the security tie is broken or missing, consult the appropriate Genie service manual.

- 6 Simultaneously hold the auxiliary power switch on and activate the desired function.



The boom, steer and drive functions will operate with auxiliary power.

## Operation from Ground

- 1 Be sure both battery packs are connected before operating the machine.
- 2 Turn the key switch to ground control.
- 3 Pull out the red Emergency Stop button to the on position.

### To Position Platform

- 1 Hold the function enable switch to either side.
- 2 Move the appropriate toggle switch according to the markings on the control panel.



Drive and steer functions are not available from the ground controls.

## Operation from Platform

- 1 Be sure that both battery packs are connected before operating the machine.
- 2 Turn the key switch to platform control.
- 3 Pull out both ground and platform red Emergency Stop buttons to the on position.

### To Position Platform

- 1 Set the boom function speed controller to the desired speed.

Note: Drive and steer functions are not affected by the boom function speed controller.

- 2 Press down the foot switch.
- 3 Move the appropriate toggle switch according to the markings on the control panel.

## OPERATING INSTRUCTIONS

**To Steer**

- 1 Press down the foot switch.
- 2 Turn the steer wheels with the thumb rocker switch located on top of the drive control handle.

Use the color-coded direction triangles on the platform controls and the drive chassis to identify the direction the wheels will turn.

**To Drive**

- 1 Press down the foot switch.
- 2 Increase speed: Slowly move the drive control handle off center.

Decrease speed: Slowly move the drive control handle toward center.

Stop: Return the drive control handle to center or release the foot switch.

Use the color-coded direction arrows on the platform controls and the drive chassis to identify the direction the machine will travel.

Machine travel speed is restricted when the booms are raised or extended.

Battery condition will affect machine performance.

**Driving on a slope**

Determine the uphill, downhill and side slope ratings for the machine and determine the slope grade.



Maximum slope rating, counterweight uphill (gradeability):  
Z-34/22N: 35% (19°)  
Z-34/22 DC: 30% (17°)



Maximum slope rating, counterweight downhill: 20% (11°)



Maximum side slope rating: 25% (14°)

Note: Slope rating is subject to ground conditions and adequate traction. The term gradeability applies to the counterweight uphill configuration only.

Be sure the boom is below horizontal and the platform is between the non-steer wheels.

## OPERATING INSTRUCTIONS

**To determine the slope grade:**

Measure the slope with a digital inclinometer OR use the following procedure.

You will need:

- carpenter's level
- straight piece of wood, at least 3 feet / 1 m long
- tape measure

Lay the piece of wood on the slope.

At the downhill end, lay the level on the top edge of the piece of wood and lift the end until the piece of wood is level.

While holding the piece of wood level, measure the distance from the bottom of the piece of wood to the ground.

Divide the tape measure distance (rise) by the length of the piece of wood (run) and multiply by 100.

Example:

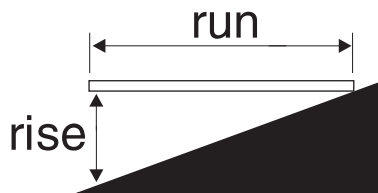

Piece of wood = 144 inches (3.6 m)

Run = 144 inches (3.6 m)

Rise = 12 inches (0.3 m)

$12 \text{ in} \div 144 \text{ in} = 0.083 \times 100 = 8.3\% \text{ grade}$

$0.3 \text{ m} \div 3.6 \text{ m} = 0.083 \times 100 = 8.3\% \text{ grade}$

If the slope exceeds the maximum uphill, downhill or side slope rating, then the machine must be winched or transported up or down the slope. See Transport and Lifting section.

**Drive Enable**

Light on indicates that the boom has moved past either non-steer wheel and the drive function has been interrupted.



To drive, hold the drive enable switch up or down and slowly move the drive control handle off center.

Be aware that the machine may move in the opposite direction that the drive and steer controls are moved.

Always use the color-coded direction arrows on the platform controls and the drive chassis to identify the direction the machine will travel.

**Low Voltage Interrupt (if equipped)**

Machines equipped with Low Voltage Interrupt will lose primary and secondary boom up functions from the platform when the batteries are low.

## OPERATING INSTRUCTIONS

## Machine Not Level Indicator Light



**ANSI, CSA and AUS models:** Light on indicates the machine is not level.

The tilt alarm will be sounding when this light is on. Identify the condition of the boom on the slope as shown below. Follow the steps to lower the boom before moving to a firm, level surface. Do not rotate the boom while lowering.

**CE models:** If the tilt alarm sounds when the platform is raised, the Machine Not Level indicator light will come on and the drive function in one or both directions will not operate. Identify the condition of the boom on the slope as shown below. Follow the steps to lower the boom before moving to a firm, level surface. Do not rotate the boom while lowering.

**All models:** If the tilt alarm sounds with the platform uphill:

- 1 Lower the primary boom.
- 2 Lower the secondary boom.
- 3 Retract the primary boom.

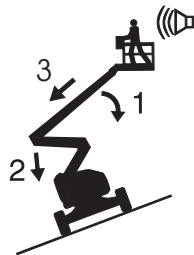

If the tilt alarm sounds with the platform downhill:

- 1 Retract the primary boom.
- 2 Lower the secondary boom.
- 3 Lower the primary boom.

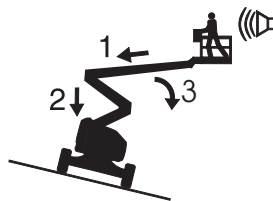

## Platform Overload Indicator Light (if equipped)



Light flashing indicates the platform is overloaded and no functions will operate.

Remove weight from the platform until the light goes off.

## Aircraft Protection Package (If equipped)

If the platform bumpers come into contact with aircraft components, the machine will shut down and no functions will operate.

- 1 Start the engine.
- 2 Press down the foot switch.
- 3 Move and hold the aircraft protection function override switch.
- 4 Move the appropriate function control handle or toggle switch to move the machine away from aircraft components.

## OPERATING INSTRUCTIONS

## Fall Protection

Personal fall protection equipment (PFPE) is required when operating this machine.

All PFPE must comply with applicable governmental regulations, and must be inspected and used in accordance with the PFPE manufacturer's instructions.

## After Each Use

- 1 Select a safe parking location—firm level surface, clear of obstruction and traffic.
- 2 Lower the boom to the stowed position.
- 3 Rotate the turntable so that the boom is between the non-steer wheels.
- 4 Turn the key switch to the off position and remove the key to secure from unauthorized use.
- 5 Charge the batteries.

## OPERATING INSTRUCTIONS



## Battery and Charger Instructions

### Observe and Obey:

- Do not use external charger or booster batteries.
- Charge the batteries in a well-ventilated area.
- Use proper AC input voltage for charging as indicated on the charger.
- Use only Genie authorized batteries and charger.

### To Charge the Batteries

- 1 Be sure the batteries are connected before charging the batteries.
- 2 Open the battery compartment. The compartment should remain open for the entire charging cycle.

#### Maintenance-free batteries

- 1 Connect the battery charger to a grounded AC circuit.
- 2 The charger will indicate when the battery is fully charged.

#### Standard Batteries

- 1 Remove the battery vent caps and check the battery acid level. If necessary, add only enough distilled water to cover the plates. Do not overfill prior to the charge cycle.
- 2 Replace the battery vent caps.
- 3 Connect the battery charger to a grounded AC circuit.
- 4 The charger will indicate when the battery is fully charged.
- 5 Check the battery acid level when the charging cycle is complete. Replenish with distilled water to the bottom of the fill tube. Do not overfill.

### Dry Battery Filling and Charging Instructions

- 1 Remove the battery vent caps and permanently remove the plastic seal from the battery vent openings.
- 2 Fill each cell with battery acid (electrolyte) until the level is sufficient to cover the plates.

Do not fill to maximum level until the battery charge cycle is complete. Overfilling can cause the battery acid to overflow during charging. Neutralize battery acid spills with baking soda and water.

- 3 Install the battery vent caps.
- 4 Charge the battery.
- 5 Check the battery acid level when the charging cycle is complete. Replenish with distilled water to the bottom of the fill tube. Do not overfill.



# Transport and Lifting Instructions



## Observe and Obey:

- ☑ The transport vehicle must be parked on a level surface.
- ☑ The transport vehicle must be secured to prevent rolling while the machine is being loaded.
- ☑ Be sure the vehicle capacity, loading surfaces and chains or straps are sufficient to withstand the machine weight. See the serial plate for the machine weight.
- ☑ The machine must be on a level surface or secured before releasing the brakes.
- ☑ Do not drive the machine on a slope that exceeds the slope or side slope rating. See Driving on a Slope in the Operating Instructions section.
- ☑ If the slope of the transport vehicle bed exceeds the uphill or downhill maximum slope rating, the machine must be loaded and unloaded using a winch as described.

## Free-wheel Configuration for Winching

- 1 Chock the wheels to prevent the machine from rolling.
- 2 Release the non-steer wheel brakes by turning over the torque hub disconnect caps (see below).
- 3 Be sure the winch line is properly secured to the drive chassis tie points and the path is clear of all obstructions.

After the machine is loaded:

- 1 Chock the wheels to prevent the machine from rolling.
- 2 Apply the non-steer wheel brakes by turning over the torque hub disconnect caps (see below).

Towing the Genie Z-34/22 or the Genie Z-34/22N is not recommended. If the machine must be towed, do not exceed 2 mph / 3.2 km/h.

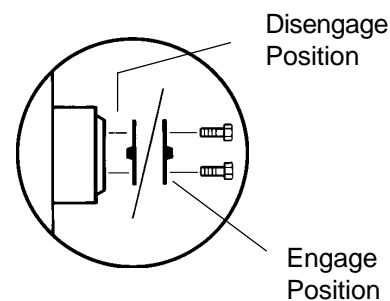

## TRANSPORT AND LIFTING INSTRUCTIONS

## Securing to Truck or Trailer for Transit

Always chock the machine wheels in preparation for transport.

Turn the key switch to the off position and remove the key before transporting.

Inspect the entire machine for loose or unsecured items.

### Securing the Chassis

Use the tie points on the drive chassis for anchoring down to the transport surface.

Use chains or straps of ample load capacity.

Use a minimum of 4 chains.

Adjust the rigging to prevent damage to the chains.

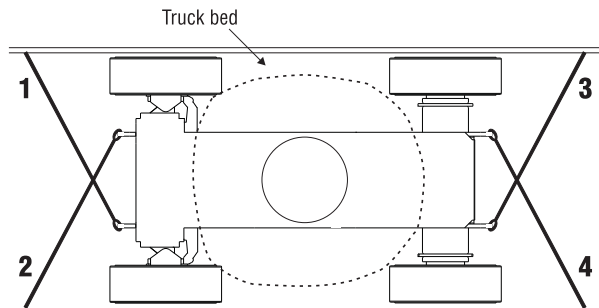

### Securing the Platform

Make sure the jib and platform are in the stowed position.

Place a block under the edge of the platform beneath the platform entry.

Secure the platform with a nylon strap placed over the platform mount near the platform rotator (see below). Do not use excessive downward force when securing the boom section.

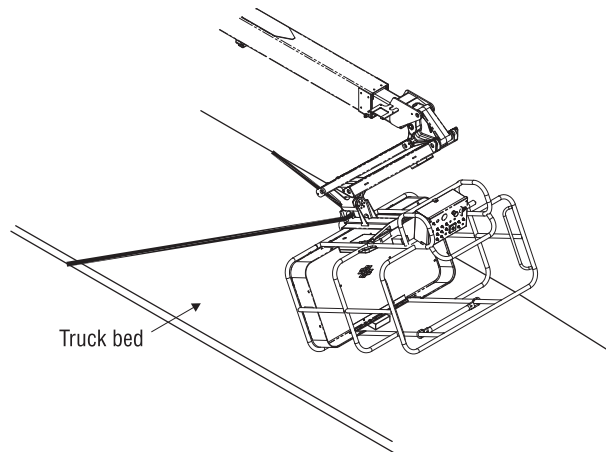

## TRANSPORT AND LIFTING INSTRUCTIONS

**Observe and Obey:**

- ☑ Only qualified riggers should rig and lift the machine.
- ☑ Be sure the crane capacity, loading surfaces and straps or lines are sufficient to withstand the machine weight. See the serial plate for the machine weight.

**Lifting Instructions**

Fully lower and retract the boom. Fully lower the jib. Remove all loose items on the machine.

Determine the center of gravity of your machine using the table and the picture on this page.

Attach the rigging only to the designated lifting points on the machine. There are four lifting points on the chassis.

Adjust the rigging to prevent damage to the machine and to keep the machine level.

Model	Z-34/22	Z-34/22N
X Axis	30.7 in 74.6 cm	34 in 86.3 cm
Y Axis	38.8 in 98.6 cm	32 in 81.2 cm

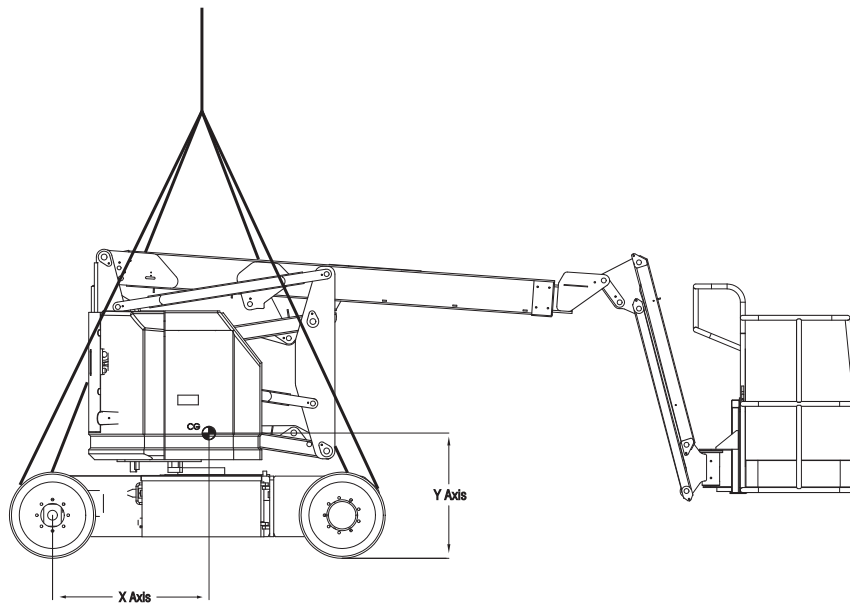

# Decals

## Inspection for Decals with Words

Determine whether the decals on your machine have words or symbols. Use the appropriate inspection to verify that all decals are legible and in place.

Part No.	Decal Description	Quantity
27564	Danger - Electrocutation Hazard	2
28161	Warning - Crushing Hazard	3
28164	Notice - Hazardous Materials	1
28165	Notice - Foot Switch	1
28171	Label - No Smoking	1
28174	Label - Power to Platform, 230V	2
28175	Caution - Compartment Access	1
28176	Notice - Missing Manuals	1
28177	Warning - Platform Rotate	2
28181	Warning - No Step or Ride	1
28235	Label - Power to Platform, 115V	2
28236	Warning - Failure To Read . . .	1
28372	Caution - Component Damage	2
31060	Danger - Tip-over Hazard, Interlock	4
31508	Notice - Power to Charger	1
31784**	Notice - Tire Specifications, Z-34/22 DC	4
31785	Notice - Battery Charger Instructions	2
31788	Danger - Battery/Charger Safety	2
32728	Label - Inverter Option Patch	1
35542	Notice - Tire Specifications, Z-34/22N	4
37052	Notice - Maximum Load, 500 lbs / 227 kg	1
37053	Arrow - Blue	1
37054	Arrow - Yellow	1
37055	Triangle - Blue	2
37056	Triangle - Yellow	2
40299	Notice - Battery Connection Diagram	2
40300	Danger - Tip-over, Batteries	2
40434	Label - Lanyard Anchorage	2

Part No.	Decal Description	Quantity
43595*	Danger - Tip-over Hazard, Tires (Z-34/22 DC only)	4
44248	Label - Maximum Capacity, 440 lbs (Aircraft Protection Package)	1
44980	Label - Power to Charger, EE	1
44981	Label - Air Line to Platform	2
44986	Notice - Max Manual Force, 90 lbs / 400 N	1
46468	Label - Function Override (Aircraft Protection Package)	1
52947	Notice - Operating Instructions, Ground	1
52968	Cosmetic - Genie Boom	1
62930	Cosmetic - Genie Z-34/22	1
62931	Cosmetic - Genie Z-34/22 DC Power	2
62932	Cosmetic - Genie Z-34/22N	1
62933	Cosmetic - Genie Z-34/22N	2
65171	Label - Circuit Breaker & Status Light	1
65301*	Notice - Tire Specifications, Z-34/22 DC	4
72081	Platform Control Panel	1
72833	Label - Open	2
72867	Label - Work Lights Option Patch	1
72999	Label - Environ MV46	1
82161	Label - UCON Hydrolube, HP-5046	1
82366	Label - Chevron Rando	1
82592	Ground Control Panel	1
97890	Danger - Safety Rules	2
97893	Notice - Max Side Force, 150 lbs / 667 N	1
114397	Danger - Tilt-Alarm	1
133286	Label - Power to Charger, Universal	1
139587	Label - Wheel Load, Z-34/22 DC	4
139590	Label - Wheel Load, Z-34/22N	4
1000043	Notice - Operating Instructions, Platform	1

\* Australia market only

\*\* ANSI market only



DECALS

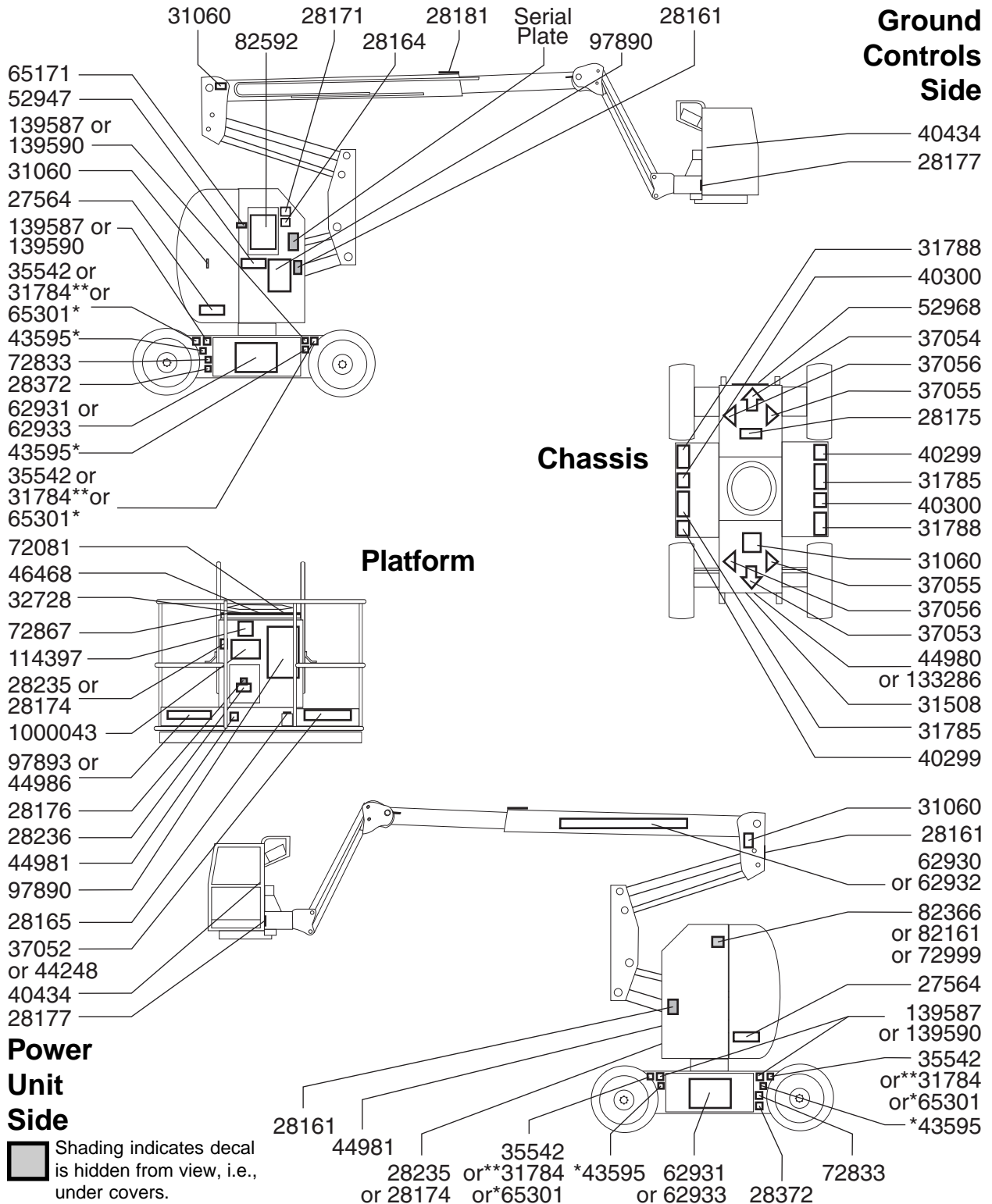

## DECALS

## Inspection for Decals with Symbols

Determine whether the decals on your machine have words or symbols. Use the appropriate inspection to verify that all decals are legible and in place.

Part No.	Decal Description	Quantity
28171	Label - No Smoking	1
28174	Label - Power to Platform, 230V	2
28235	Label - Power to Platform, 115V	2
32728	Label - Inverter Option Patch	1
37053	Arrow - Blue	1
37054	Arrow - Yellow	1
37055	Triangle - Blue	2
37056	Triangle - Yellow	2
40434	Label - Lanyard Anchorage	2
44981	Label - Air Line to Platform	2
46468	Label - Function Override (Aircraft Protection Package)	1
52968	Cosmetic - Genie Boom	1
62930	Cosmetic - Genie Z-34/22	1
62931	Cosmetic - Genie Z-34/22 DC Power	2
62932	Cosmetic - Genie Z-34/22N	1
62933	Cosmetic - Genie Z-34/22N	2
72081	Platform Control Panel	1
72867	Label - Work Lights Option Patch	1
82472	Warning - Crushing Hazard	3

Part No.	Decal Description	Quantity
82481	Danger - Battery Safety	2
82487	Label - Operating Instructions	2
82544	Danger - Electrocutation Hazard	2
82548	Warning - Platform Rotate	2
82592	Ground Control Panel	1
82601	Danger - Maximum Capacity, 227 kg	1
82602	Danger - Maximum Side Force, 667 N	1
82604	Danger - Maximum Manual Force, 400 N	1
82610	Label - Circuit Breaker & Status Light	1
82611	Label - Drive Enable Patch	1
82612	Label - Maximum Capacity, 200 kg (Aircraft Protection Package)	1
82942**	Label - Tire Pressure, (Z-34/22 DC only)	4
97815	Label - Lower Mid-rail	1
114249*	Danger - Tip-over Hazard, Tires (Z-34/22 DC only)	4
114343	Label - Emergency Lowering	1
133286	Label - Power to Charger	1
139587	Label - Wheel Load, Z-34/22 DC	4
139590	Label - Wheel Load, Z-34/22N	4

\* CE market only

\*\* ANSI market only

DECALS

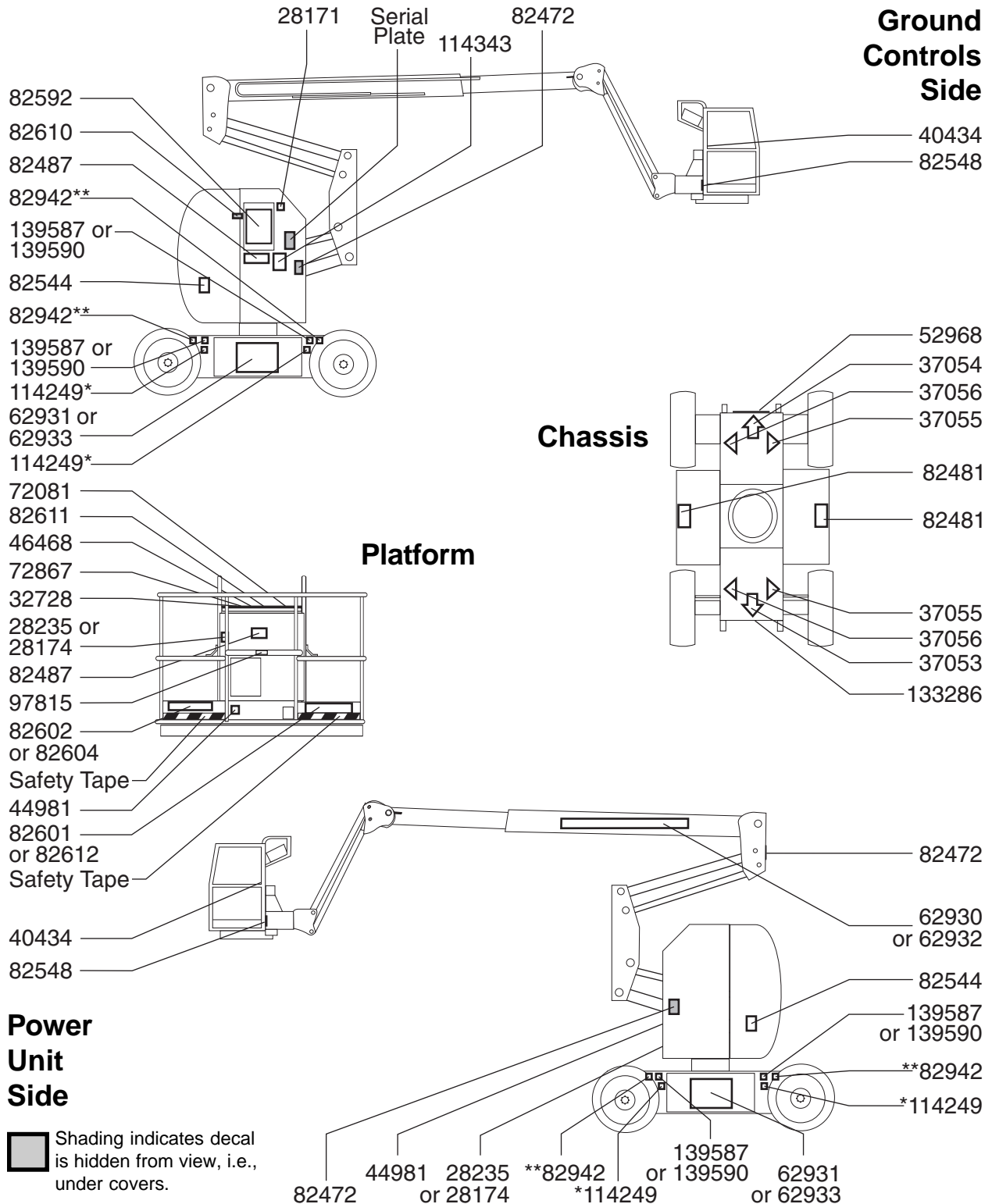

# Specifications

## Z-34/22N

Height, working maximum	40 ft 6 in	12.5 m
Height, platform maximum	34 ft 6 in	10.5 m
Height, stowed maximum	6 ft 7 in	2 m
Horizontal reach maximum	22 ft 3 in	6.8 m
Width	4 ft 10 in	1.5 m
Length, stowed	18 ft 9 in	5.7 m
Maximum load capacity	500 lbs	227 kg
Maximum wind speed	28 mph	12.5 m/s
Wheelbase	6 ft 2 in	1.9 m
Turning radius (outside)	13 ft 5 in	4.1 m
Turning radius (inside)	7 ft	2.1 m
Ground clearance	5 in	12.7 cm
Turntable rotation (degrees)		355°
Turntable tailswing		0
Power source	8 Group 902, J305, 6V 315AH Batteries	

## Drive speeds, maximum

Boom stowed	4.0 mph	6.4 km/h
	40 ft/6.8 sec	12.2 m/6.8 sec
Boom raised or extended	0.6 mph	1.0 km/h
	40 ft/40 sec	12.2 m/40 sec
Controls	24V DC proportional	
Platform dimensions, (length x width)	56 in x 30 in 1.42 m x 76 cm	

Platform leveling	self-leveling
Platform rotation	160°
AC outlet in platform	standard
Hydraulic pressure, maximum (boom functions)	2800 psi 193 bar
System voltage	48V
Tires size, solid rubber	22 x 7 x 17 <sup>3</sup> / <sub>4</sub> in

Total vibration value to which the hand/arm system is subjected does not exceed 2.5 m/s<sup>2</sup>

Highest root mean square value of weighted acceleration to which the whole body is subjected does not exceed 0.5 m/s<sup>2</sup>

Weight See Serial Plate  
(Machine weights vary with option configurations)

## Maximum slope rating, stowed position

Counterweight uphill	35%	19°
Counterweight downhill	20%	11°
Side slope	25%	14°

Note: Slope rating is subject to ground conditions and adequate traction.

## Airborne noise emissions

Sound pressure level at ground workstation	< 70 dBA
Sound pressure level at platform workstation	< 70 dBA

## Floor Loading Information

Tire load, maximum	6450 lbs	2926 kg
Tire contact pressure (per tire)	103 psi	7.24 kg/cm <sup>2</sup> 710 kPa
Occupied floor pressure	308 psf	14.75 kPa 1504 kg/m <sup>2</sup>

Note: Floor loading information is approximate and does not incorporate different option configurations. It should be used only with adequate safety factors.

**Continuous improvement of our products is a Genie policy. Product specifications are subject to change without notice or obligation.**





## SPECIFICATIONS

**Z-34/22**

Height, working maximum	40 ft 6 in	12.5 m
Height, platform maximum	34 ft 6 in	10.5 m
Height, stowed maximum	6 ft 7 in	2 m
Horizontal reach maximum	22 ft 3 in	6.8 m
Width	5 ft 8 in	1.7 m
Length, stowed	18 ft 6 in	5.6 m
Maximum load capacity	500 lb	227 kg
Maximum wind speed	28 mph	12.5 m/s
Wheelbase	6 ft 2 in	1.9 m
Turning radius (outside)	13 ft 1 in	4 m
Turning radius (inside)	5 ft 9 in	1.8 m
Ground clearance	6 in	15 cm
Turntable rotation (degrees)		355°
Turntable tailswing		0
Power source	8 Group 902, J305, 6V 315AH Batteries	

**Drive speeds, maximum**

Boom stowed,	4 mph	6.4 km/h
	40 ft/6.8 sec	12.2 m/6.8 sec
Booms raised or extended	0.6 mph	1.0 km/h
	40 ft/40 sec	12.2 m/40 sec
Controls	24V DC proportional	
Platform dimensions, (length x width)	56 in x 30 in 1.42 m x 76 cm	

Platform leveling	self-leveling	
Platform rotation	160°	
AC outlet in platform	standard	
Hydraulic pressure, maximum (boom functions)	2800 psi 193 bar	
System voltage	48V	
Tires size, ANSI	Size 9-14.5 LT	
Tire size, CE and Australia Foam filled only	9-14.5	

Total vibration value to which the hand/arm system is subjected does not exceed 2.5 m/s<sup>2</sup>

Highest root mean square value of weighted acceleration to which the whole body is subjected does not exceed 0.5 m/s<sup>2</sup>

Weight See Serial Plate  
(Machine weights vary with option configurations)

**Maximum slope rating, stowed position**

Counterweight uphill	30%	17°
Counterweight downhill	20%	11°
Side slope	25%	14°

Note: Slope rating is subject to ground conditions and adequate traction.

**Airborne noise emissions**

Sound pressure level at ground workstation	< 70 dBA
Sound pressure level at platform workstation	< 70 dBA

**Floor Loading Information**

Tire load, maximum	5850 lbs	2654 kg
Tire contact pressure (per tire)	100 psi	7.03 kg/cm <sup>2</sup> 689 kPa
Occupied floor pressure	239 psf	11.44 kPa 1167 kg/m <sup>2</sup>

Note: Floor loading information is approximate and does not incorporate different option configurations. It should be used only with adequate safety factors.

**Continuous improvement of our products is a Genie policy. Product specifications are subject to change without notice or obligation.**



SPECIFICATIONS

Range of Motion

