

General Specs

		DL200-5 Standard (US10)	DL200TC-5 Tool Carrier (US10)	DL220-5 Standard (US10)	DL250-5 Standard (US10)	DL250TC-5 Tool Carrier (US10)	DL280-5 Standard (US10)
ENGINE							
MAKE		Perkins	Perkins	Doosan	Doosan	Doosan	Doosan
MODEL		1204F	1204F	DL06	DL06	DL06	DL06
NUMBER OF CYLINDERS	INLINE	4	4	6	6	6	6
RATED POWER, GROSS (per SAE J1995)	hp (kW) @ rpm	142 (106) @ 2200	142 (106) @ 2200	160 (119) @ 2100	172 (128) @ 2100	172 (128) @ 2100	172 (128) @ 2100
MAXIMUM TORQUE, GROSS (per SAE J1995)	ft.-lb. (kgf-m) @ rpm	413 (57) @ 1400	413 (57) @ 1400	542 (75) @ 1400	593 (82) @ 1400	593 (82) @ 1400	593 (804) @ 1400
PISTON DISPLACEMENT	in. ³ (L)	269 (4.4)	269 (4.4)	360 (5.9)	360 (5.9)	360 (5.9)	360 (5.9)
BORE AND STROKE	in. x in. (mm x mm)	4.1" x 5" (105 x 127)	4.1" x 5" (105 x 127)	3.9" x 4.9" (100 x 125)	3.9" x 4.9" (100 x 125)	3.9" x 4.9" (100 x 125)	3.9" x 4.9" (100 x 125)
STARTER	V, hp (kW)	24, 7.4 (5.5)	24, 7.4 (5.5)	24, 8 (6)	24, 8 (6)	24, 8 (6)	24, 8 (6)
BATTERY (2)	V, AH, CCA	2x12, 100, 900	2x12, 100, 900	2x12, 100, 900	2x12, 100, 900	2x12, 100, 900	2x12, 100, 900
ALTERNATOR	V, amp	24, 85	24, 85	24, 80	24, 80	24, 80	24, 80
AIR CLEANER		Double Element	Double Element	Double Element	Double Element	Double Element	Double Element
HYDRAULICS							
MAIN PUMPS	gpm (L/min.)	49 (184)	49 (184)	41 (155)	41 (155)	41 (155)	55.5 (210)
SYSTEM PRESSURE (WORK)	psi (kg/cm ²)	3190 (224)	3190 (224)	3626 (255)	3843 (270)	3843 (270)	3843 (270)
SYSTEM PRESSURE (STEER)	psi (kg/cm ²)	2830 (199)	2828 (199)	2828 (199)	3843 (270)	3843 (270)	3843 (270)
BOOM SPEED	UP (UNLOADED)	sec.	5.7	5.1	6	6	6.3
	DOWN	sec.	3.6	4.2	3.5	3.7	3.2
BUCKET SPEED	CROWD (UNLOADED)	sec.	1.6	3	1.9	1.9	2.1
	DUMP	sec.	1.6	2.6	1.2	1.4	1.3
ENVIRONMENT							
SOUND LEVEL (per ISO 6394)	dB(A)	102	102	102	101	101	103
CABIN SOUND LEVEL (per ISO 6394)	dB(A)	70	70	71	71	71	72
TRANSMISSION SPEEDS							
TRAVEL SPEED - FORWARD (4)	mph (km/h)	8/8/12/24 (13/13/20/38)	8/8/12/24 (13/13/20/38)	4.3/8/15/24.2 (7/12.8/24.2/39)	4.1/7.4/14.3/23.5 (6.6/11.9/23/37.8)	4.1/7.4/14.3/23.5 (6.6/11.9/23/37.8)	3.9/7.7/14.4/22.1 (6.3/12.4/23.1/35.5)
TRAVEL SPEED - REVERSE (3)	mph (km/h)	8/8/12 (13/13/20)	8/8/12 (13/13/20)	4.6/8.4/15.8 (7.4/13.5/25.4)	4.3/7.8/15 (6.9/12.5/24.2)	4.3/7.8/15 (6.9/12.5/24.2)	4.1/8.1/15 (6.6/13.1/24.2)
MAXIMUM GRADE	% (°)	55 (29)	55 (29)	58 (30)	58 (30)	58 (30)	58 (30)
REFILL CAPACITIES							
FUEL TANK	gal. (L)	45 (172)	45 (172)	58.6 (222)	58.7 (222)	58.7 (222)	58.7 (222)
DIESEL EXHAUST FLUID TANK	gal. (L)	5 (19)	5 (19)	8.3 (31.5)	8.3 (31.5)	8.3 (31.5)	8.3 (31.5)
COOLING SYSTEM (RADIATOR)	gal. (L)	8.5 (32)	8.5 (32)	10.6 (40)	10.6 (40)	10.6 (40)	8.3 (31.6)
ENGINE OIL	gal. (L)	2.8 (10.5)	2.8 (10.5)	7.1 (27)	7.1 (27)	7.1 (27)	7.1 (27)
TRANSMISSION	gal. (L)	–	–	8 (30)	8 (30)	8 (30)	9.8 (37)
GEARBOX	gal. (L)	0.7 (2.7)	0.7 (2.7)	–	–	–	–
FRONT AXLE	gal. (L)	4 (15)	4 (15)	5.7 (21.5)	9.3 (35)	9.3 (35)	9.2 (35)
REAR AXLE	gal. (L)	3.5 (13.3)	3.5 (13.3)	5.7 (21.5)	6.1 (23)	6.1 (23)	6.1 (23)
HYDRAULIC SYSTEM	gal. (L)	34.1 (129)	34.1 (129)	31.7 (120)	31.7 (120)	31.7 (120)	31.7 (120)
HYDRAULIC CYLINDERS							
STEERING (2)	BORE x ROD x STROKE	in. x in. x in. (mm x mm x mm)	2.8" x 1.4" x 14.4" (70 x 35 x 366)	2.8" x 1.4" x 14.4" (70 x 35 x 366)	2.8" x 1.8" x 16.7" (70 x 45 x 425)	2.8" x 1.8" x 16.7" (70 x 45 x 425)	2.8" x 1.8" x 16.7" (70 x 45 x 425)
LIFT (2)	BORE x ROD x STROKE	in. x in. x in. (mm x mm x mm)	4.9" x 3.0" x 26" (125 x 75 x 669)	4.3" x 3.0" x 31" (110 x 75 x 790)	4.5" x 3.0" x 31.1" (115 x 75 x 790)	4.5" x 3.0" x 31.1" (115 x 75 x 790)	5.3" x 3.1" x 31.1" (135 x 80 x 790)
BUCKET (1) *	BORE x ROD x STROKE	in. x in. x in. (mm x mm x mm)	5.1" x 2.9" x 20" (130 x 75 x 509)	4.1" x 2.6" x 33" (105 x 65 x 843)*	5.1" x 3.1" x 20.3" (130 x 80 x 515)	5.1" x 3.1" x 20.3" (130 x 80 x 515)	4.1" x 2.6" x 34.7" (105 x 65 x 881)*

* The DL200TC-5 and DL250TC-5 have TWO bucket cylinders.

NOTE — Where applicable, dimensions are in accordance with Society of Automotive Engineers (SAE) and ISO standards. Specifications and design are subject to change without notice. Pictures of Doosan wheel loaders may show other than standard equipment. All dimensions are shown in inches. Respective metric dimensions are enclosed by parentheses. Doosan Construction Equipment is manufactured with a Quality Management System that is in compliance with ISO 9001:2008.

All dimensions are given for Doosan wheel loaders equipped with standard tires.

Operational Data

		DL200-5		DL200TC-5	DL220-5	
		Standard (US10)	High Lift (US20)	Tool Carrier (US10)	Standard (US10)	High Lift (US20)
BUCKET TYPE: General Purpose		BUCKET MOUNT: Pin-On		BUCKET CONFIGURATION: Bolt-On Edge		
BUCKET CAPACITY, HEAPED ISO/SAE	yd ³ (m ³)	2.6 (2)	2.6 (2)	2.6 (2)	3 (2.3)	3 (2.3)
BUCKET WIDTH	A ft.-in. (mm)	8' 4" (2550)	8' 4" (2550)	8' 4" (2550)	8' 4" (2550)	8' 4" (2550)
HINGE PIN HEIGHT, MAXIMUM	B ft.-in. (mm)	12' 3" (3730)	13' 9" (4200)	12' 6" (3810)	12' 8" (3860)	14' 1" (4300)
DUMP HEIGHT (45°) - FULLY RAISED	C ft.-in. (mm)	9' 6" (2887)	11' (3347)	8' 10" (2685)	9' 3" (2825)	10' 9" (3270)
DUMP REACH (45°) - FULLY RAISED	D ft.-in. (mm)	40" (1015)	39" (985)	37" (945)	42" (1065)	41" (1040)
DIGGING DEPTH	E ft.-in. (mm)	2.4" (60)	6.9" (175)	3.1" (80)	3.5" (90)	7.9" (200)
OVERALL HEIGHT, ROPS CABIN	F ft.-in. (mm)	10' 9" (3280)	10' 9" (3280)	10' 9" (3280)	10' 9" (3280)	10' 9" (3280)
OVERALL LENGTH	G ft.-in. (mm)	23' 5" (7135)	24' 10" (7580)	24' (7315)	24' 5" (7445)	25' 11" (7905)
WHEEL BASE	H ft.-in. (mm)	9' 6" (2900)	9' 6" (2900)	9' 6" (2900)	9' 11" (3010)	9' 11" (3010)
WIDTH AT TIRES	I ft.-in. (mm)	8' 4" (2530)	8' 4" (2530)	8' 4" (2530)	8' 1" (2460)	8' 1" (2460)
TREAD WIDTH	J ft.-in. (mm)	6' 4" (1930)	6' 4" (1930)	6' 4" (1930)	6' 4" (1930)	6' 4" (1930)
GROUND CLEARANCE	K ft.-in. (mm)	1' 5" (435)	1' 5" (435)	1' 5" (435)	1' 5" (435)	1' 5" (435)
MAX. TILT ANGLE ON GROUND	°	43	43	52	42	43
MAX. TILT ANGLE AT CARRY POSITION	L °	49	50	52	48	51
MAX. TILT ANGLE AT FULLY RAISED	M °	60	63	53	59	61
MAX. DUMP ANGLE (FULLY RAISED)	N °	47	45	47	48	46
STEERING ANGLE, MAXIMUM	O °	40	40	40	40	40
EXTERNAL RADIUS, BUCKET EDGE	P ft.-in. (mm)	19' (5795)	19' 6" (5935)	18' 10" (5740)	19' 6" (5950)	20' (6100)
EXTERNAL RADIUS, OUTSIDE TIRE	Q ft.-in. (mm)	17' 2" (5245)	17' 2" (5245)	17' 2" (5245)	18' (5475)	18' (5475)
TIRE SIZE		20.5-R25 (L3)	20.5-R25 (L3)	20.5-R25 (L3)	20.5-R25 (L3)	20.5-R25 (L3)
OPERATING WEIGHT	lb. (kg)	25,795 (11,700)	26,566 (12,050)	26,224 (11,895)	27,381 (12,420)	28,296 (12,835)
STATIC TIPPING LOAD (STRAIGHT)	lb. (kg)	21,075 (9560)	17,955 (8145)	18,825 (8540)	21,230 (9630)	19,412 (8805)
STATIC TIPPING LOAD (AT FULL TURN)	lb. (kg)	18,620 (8445)	15,850 (7190)	16,625 (7540)	18,750 (8505)	17,141 (7775)
BREAKOUT FORCE	lbf. (kgf)	22,480 (10,197)	22,930 (10,401)	21,355 (9686)	22,706 (10,299)	25,180 (11,421)

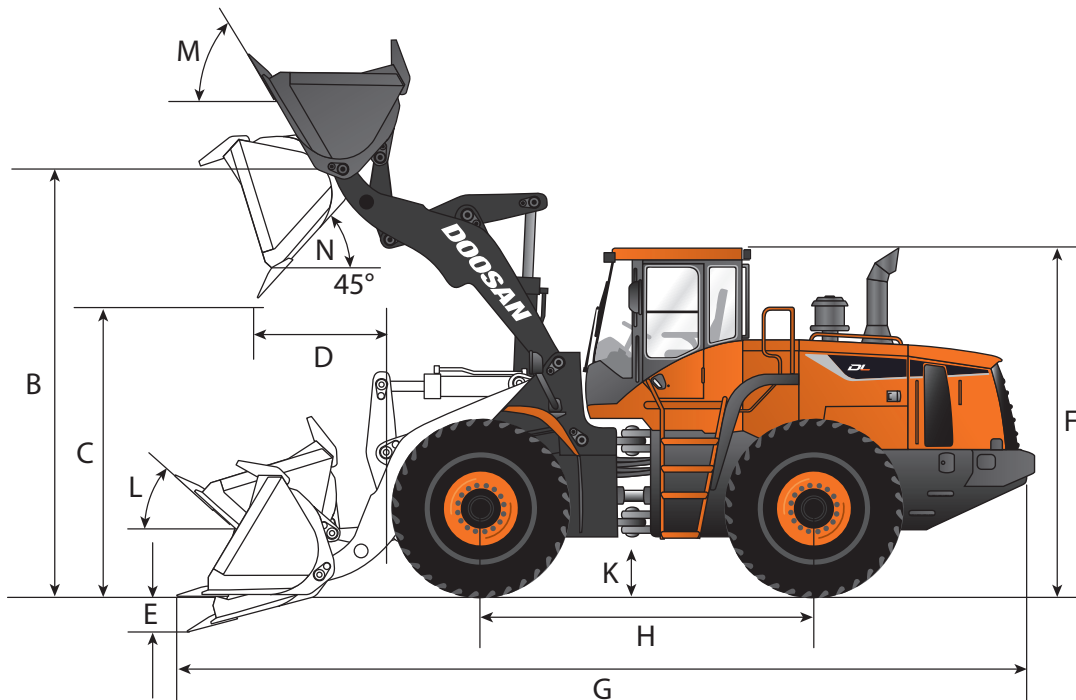

Operational Data *Continued*

		DL250-5		DL250TC-5	DL280-5	
		Standard (US10)	High Lift (US20)	Tool Carrier (US10)	Standard (US10) Standard (US30) HD	High Lift (US20) High Lift (US40) HD
BUCKET TYPE: General Purpose		BUCKET MOUNT: Pin-On		BUCKET CONFIGURATION: Bolt-On Edge		
CAPACITY HEAPED ISO/SAE		yd ³ (m ³)	3.3 (2.5)	3.3 (2.5)	3.3 (2.5)	3.7 (2.8)
BUCKET WIDTH	A	ft.-in. (mm)	8' 11" (2740)	8' 11" (2740)	8' 11" (2740)	9' (2740)
HINGE PIN HEIGHT, MAXIMUM	B	ft.-in. (mm)	12' 7" (3858)	14' 2" (4325)	12' 10" (3934)	12' 11" (3940) 13' (3975)
DUMP HEIGHT (45°) - FULLY RAISED	C	ft.-in. (mm)	9' 2" (2802)	10' 7" (3246)	9' (2749)	9' 2" (2802)
DUMP REACH (45°) - FULLY RAISED	D	ft.-in. (mm)	42" (1073)	40" (1034)	4' 3" (1299)	3' 9" (1150)
DIGGING DEPTH	E	ft.-in. (mm)	3.9" (98)	5.4" (137)	3.4" (87)	4.5" (115)
OVERALL HEIGHT, ROPS CABIN	F	ft.-in. (mm)	10' 9" (3280)	10' 9" (3280)	10' 9" (3280)	10' 10" (3310) 11' (3345)
OVERALL LENGTH	G	ft.-in. (mm)	24' 6" (7475)	25' 9" (7865)	25' 7" (7805)	25' 3" (7700)
WHEEL BASE	H	ft.-in. (mm)	9' 10" (3020)	9' 10" (3020)	9' 10" (3020)	9' 11" (3010)
WIDTH AT TIRES	I	ft.-in. (mm)	8' 7" (2640)	8' 7" (2640)	8' 7" (2640)	8' 5" (2570)
TREAD WIDTH	J	ft.-in. (mm)	6' 8" (2040)	6' 8" (2040)	6' 8" (2040)	6' 8" (2040)
GROUND CLEARANCE	K	ft.-in. (mm)	1' 5" (435)	1' 5" (435)	1' 5" (435)	1' 4" (397) 1' 5" (432)
MAX. TILT ANGLE ON GROUND		°	42	43	40	42
MAX. TILT ANGLE AT CARRY POSITION	L	°	48	51	48	48
MAX. TILT ANGLE AT FULLY RAISED	M	°	59	61	51	62
MAX. DUMP ANGLE (FULLY RAISED)	N	°	48	45	50	46
STEERING ANGLE, MAXIMUM	O	°	40	40	40	40
EXTERNAL RADIUS, BUCKET EDGE	P	ft.-in. (mm)	19' 9" (6045)	20' 1" (6134)	17' 11" (5475)	20' (6085)
EXTERNAL RADIUS, OUTSIDE TIRE	Q	ft.-in. (mm)	18' (5475)	18' (5475)	18' (5475)	17' 9" (5420)
TIRE SIZE			20.5-R25 (L3)	20.5-R25 (L3)	20.5-R25 (L3)	20.5-R25 (L3)
OPERATING WEIGHT		lb. (kg)	30,115 (13,660)	31,129 (14,120)	31,592 (14,330)	34,262 (15,541) 36,345 (16,489)
STATIC TIPPING LOAD (STRAIGHT)		lb. (kg)	23,997 (10,885)	21,440 (9725)	20,470 (9285)	26,486 (12,014) 29,357 (13,316)
STATIC TIPPING LOAD (AT FULL TURN)		lb. (kg)	21,186 (9610)	18,927 (8585)	18,078 (8200)	23,389 (10,609) 25,922 (11,758)
BREAKOUT FORCE		lbf. (kgf)	23,830 (10,809)	23,380 (10,605)	22,930 (10,401)	30,349 (13,766)

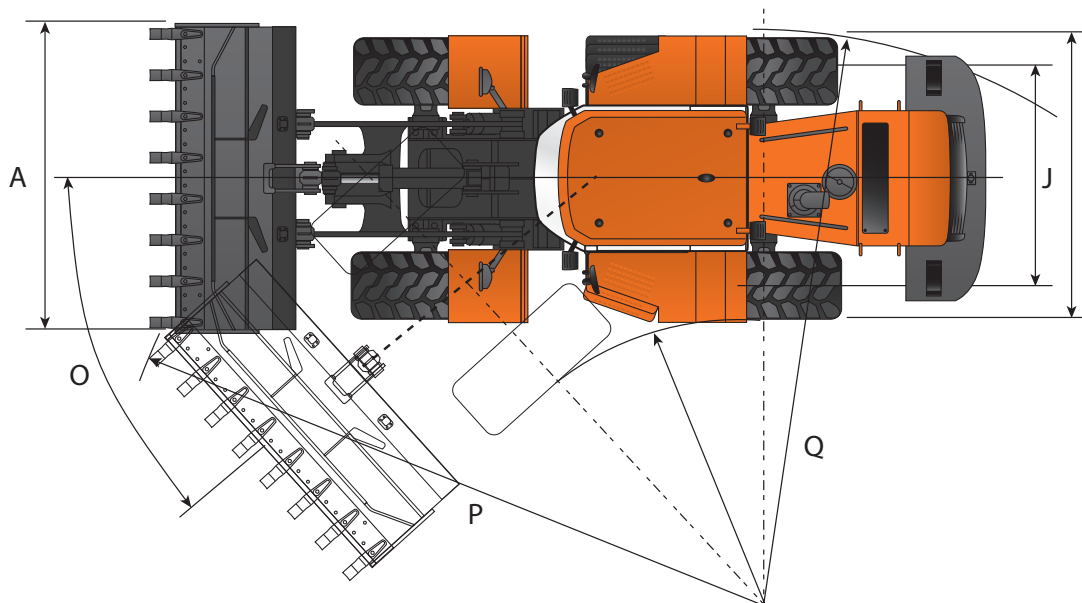

Specifications

Standard/Optional Equipment

	DL200-5	DL200TC-5	DL220-5	DL250-5	DL250TC-5	DL280-5
ENGINE						
Emissions (EPA)	T4	T4	T4	T4	T4	T4
High Pressure Common Rail (HPCR)	•	•	•	•	•	•
Cooled Exhaust Gas Recirculation (CEGR)	•	•	•	•	•	•
Diesel Oxidation Catalyst (DOC)	•	•	•	•	•	•
Selective Catalyst Reduction (SCR)	•	•	•	•	•	•
Diesel Exhaust Fluid (DEF)	•	•	•	•	•	•
Fuel Filter with Water Separator	•	•	•	•	•	•
Coolant Recovery Tank	•	•	•	•	•	•
Dual Element Dry-Type Air Filter with Evacuator	•	•	•	•	•	•
Pre Cleaner	•	•	•	•	•	•
Electronic Engine Control (ECU)	•	•	•	•	•	•
Auto-Idle (Working to Standby)	•	•	•	•	•	•
Auto-Shutdown (Time Adjustable)	•	•	•	•	•	•
Overheat & Low Oil Pressure Engine Protection	•	•	•	•	•	•
Cooling Fan - Radiator, Variable Speed	•	•	•	•	•	•
Cooling Fan - Radiator, Automatic Reversible	•	•	•	•	•	•
Radiator, Wide-Fin	-	-	-	-	-	•
Remote Drain Port - Engine Oil	•	•	•	•	•	•
Block Heater (110V)	•	•	•	•	•	•
Fuel Filler Pump	•	•	•	•	•	•
HYDRAULIC						
Variable Displacement Axial Piston Pump	•	•	•	•	•	•
Closed-Center System	•	•	•	•	•	•
Pilot Operated Control Valves	•	•	•	•	•	•
Remote Test Ports	•	•	•	•	•	•
Remote Drain Port - Hydraulic Oil	•	•	•	•	•	•
Spring Applied Hydraulic Release Parking Brake	•	•	•	•	•	•
Auxiliary Hydraulics (3rd Valve)	•	•	•	•	•	•
Auxiliary Hydraulics (4th Valve)	•	•	•	•	•	•
Automatic Boom/Lift Kick-Out, Adjustable (In Cab)	•	•	•	•	•	•
Automatic Return-to-Dig Position, Adjustable	•	•	•	•	•	•
Boom Float	•	•	•	•	•	•
Load Isolation System	•	•	•	•	•	•
ELECTRICAL						
System Voltage - 24V	•	•	•	•	•	•
Alternator - 24V, 80 Amp	-	-	•	•	•	•
Alternator - 24V, 85 Amp	•	•	-	-	-	-
2 x 12V Batteries, 100 AH Capacity, 900 CCA	•	•	•	•	•	•
Blade Type Fuse Panel	•	•	•	•	•	•
Main Circuit Breaker	•	•	•	•	•	•
Light, Work (Halogen): Front (2), Rear (2)	•	•	•	•	•	•
Light, Headlights (High/Low Beams) (2)	•	•	•	•	•	•
Light, Stop, Tail & Direction Indicators	•	•	•	•	•	•
Rotating Beacon	•	•	•	•	•	•
Hour Meter	•	•	•	•	•	•
Rearview Camera	•	•	•	•	•	•
Laptop Service Port	•	•	•	•	•	•
Self-Diagnostics System	•	•	•	•	•	•
Telematics	•	•	•	•	•	•

	DL200-5	DL200TC-5	DL220-5	DL250-5	DL250TC-5	DL280-5
CABIN						
Steel, All-Weather & Sound Suppressed	•	•	•	•	•	•
ROPS (ISO 3471)	•	•	•	•	•	•
Front & Rear Window with Wiper/Washer	•	•	•	•	•	•
Tinted Safety Glass	•	•	•	•	•	•
Visor, Retractable	•	•	•	•	•	•
Lockable Doors	•	•	•	•	•	•
Seat - Air Suspension - 2" (51 mm) Seat Belt - Adjustable Height & Recline - Adjustable Fore/Aft - Adjustable Arm Rests	•	•	•	•	•	•
Seat - Heated	•	•	•	•	•	•
3" (76 mm) Seat Belt	•	•	•	•	•	•
Control Stand - Sliding (Fore/Aft)	•	•	•	•	•	•
Storage	•	•	•	•	•	•
Mirror, Rear View (1)	•	•	•	•	•	•
Mirrors, Exterior (2) Heated	•	•	•	•	•	•
Fully Automatic HVAC with Ambient Temperature Sensor	•	•	•	•	•	•
Multi-Function LCD	•	•	•	•	•	•
Cigarette Lighter	•	•	•	•	•	•
AM/FM Stereo with CD Player & MP3 Port	•	•	•	•	•	•
Speakers (2)	•	•	•	•	•	•
Antenna, Roof-Mounted	•	•	•	•	•	•
Power Socket, 12V	•	•	•	•	•	•
Beverage Holder	•	•	•	•	•	•
Hot/Cold Compartment	•	•	•	•	•	•
Interior Light	•	•	•	•	•	•
CONTROLS						
Adjustable Steering Column - Tilting - Telescoping	•	•	•	•	•	•
Throttle Pedal (Accelerator)	•	•	•	•	•	•
Brake Pedal, Right	•	•	•	•	•	•
Brake Pedal, Left (Transmission Kick-Out)	•	•	•	•	•	•
Gear Selector (FNR)	•	•	•	•	•	•
Joystick Control	•	•	•	•	•	•
Fingertip Control (3 Lever)	•	•	•	•	•	•
Switches, Console-Mounted - Starter (Key) - Parking Brake - Pilot Cutoff - Transmission Cutoff - Work Light - Reversible Cooling Fan	•	•	•	•	•	•
Speed Management	•	•	-	-	-	-
Traction Control Management	•	•	-	-	-	-
Power Mode (P, S, E)	•	•	•	•	•	•
Transmission Mode	•	•	•	•	•	•
Wiper Control Panel	•	•	•	•	•	•
Audio Control Panel	•	•	•	•	•	•

- Standard Equipment
- Optional Equipment
- N/A

Standard/Optional Equipment *Continued*

	DL200-5	DL200TC-5	DL220-5	DL250-5	DL250TC-5	DL280-5
FRAME & DRIVELINE						
Z-Bar Lift Arm	•	–	•	•	–	•
Z-Bar Lift Arm, High Lift	■	–	■	■	–	■
Parallel Lift Arm	–	•	–	–	•	–
Steering Cylinder, Double-Acting (2)	•	•	•	•	•	•
Transmission, Automatic - Power Shift - (4F/3R Speed)	–	–	•	•	•	•
Transmission, Hydrostatic - Dual Motor	•	•	–	–	–	–
Torque Converter	–	–	•	•	•	•
Differential, Front - Limited Slip	•	•	•	•	•	•
Differential, Front - Hydraulic Locking	–	–	■	■	■	■
Differential, Rear - Limited Slip	•	•	•	•	•	•
Hydraulic Power Steering	•	•	•	•	•	•
Outboard Planetary Axles	•	•	•	•	•	•
Heavy Duty, Outboard Planetary Axles	–	–	–	–	–	■
Fixed Front Axle	•	•	•	•	•	•
Oscillating Rear Axle	•	•	•	•	•	•
Parking Brake, Spring Applied Hydraulic Release	•	•	•	•	•	•
Sealed, Self-Adjusting Brakes	•	•	•	•	•	•
Tires, 20.5R25 Bias	•	•	•	•	•	•
Tires, 20.5R25 Radial	■	■	■	■	■	■
DISPLAY MONITOR & WARNINGS						
Buzzer - Engine Oil Pressure - Coolant Temperature - Transmission Overheat	•	•	•	•	•	•
Gauges - Fuel Level - DEF Level - Engine Coolant Temperature - Transmission Oil Temperature - Engine rpm - Speedometer - Transmission Gear Indicator - Battery Voltage - ECO - Digital Clock - Trip Meter - Hour Meter - Total Operation Time - Fuel Consumption	•	•	•	•	•	•
Warning & Indicator Lights - Seat Belt - Error Code - SCR Warning - Check Engine - Engine Oil Pressure - Engine Pre-Heat Engaged - Radiator Coolant Temperature - Air Filter - Fuel Level - DEF Level - Water in Fuel - Battery Charge - Lights (High, Main, Work, Beacon) - Direction Signal - Emergency Steering - Hydraulic Oil Temperature - Hydraulic Charge Pressure Warning - Hydraulic Pilot Filter - Hydraulic Return Filter - Transmission Mode - Transmission Warning - Transmission Lock-Up - Transmission Oil Temp - Transmission Gear Indicator - Brake Fluid Pressure Warning - Reverse Fan Indicator - Mirror Heat Indicator - Parking Brake Indicator	•	•	•	•	•	•
Back-Up Alarm	•	•	•	•	•	•

	DL200-5	DL200TC-5	DL220-5	DL250-5	DL250TC-5	DL280-5
OTHER						
Centralized Lubrication	•	•	•	•	•	•
Handrails & Service Platforms	•	•	•	•	•	•
Skid-Resistant Steps & Service Platforms	•	•	•	•	•	•
Drawbar & Pin	•	•	•	•	•	•
Wheel Chocks	•	•	•	•	•	•
Rear Fender, Full	■	■	■	■	■	■
Additional Counterweight <i>*Additional counterweight is standard on all high lift machines.</i>	–	–	■	■	–	■
Manuals - Operation & Maintenance - Parts - AEM Safety Manual	•	•	•	•	•	•
Telematics, 36-Month Subscription	•	•	•	•	•	•
Vandalism Protection - Lockable Panels - Lockable Fluid Fill Points - Anti-Theft Protection (Password)	•	•	•	•	•	•

• Standard Equipment
 ■ Optional Equipment
 – N/A