

K9-3 AWD

DINGO



As with all Dingo models, the K9-3 AWD (All Wheel Drive) is covered by an industry leading warranty, coupled with quality trained service technicians to ensure that your machine will keep you working.

It's no wonder that Dingo is the world renowned No. 1 choice in Mini Diggers.



The Dingo's robust structure, narrow frame, adaptability and manoeuvrability are all unique features which give this machine the ability to go where no machine has gone before.

Dingo's reputation for excellence has made it the recognised name for Mini Diggers.

Ask for the machine that your customers will ask for by name.

Dingo, the world's toughest Mini Digger



K9-3 AWD

The ever popular Dingo K9-3 has evolved again with some great new features. Improvement in engine and hydraulic technologies combine with Dingo innovation to form the all new 4 wheel motor AWD. Increase in hydraulic flow and pressures enable greater ground speed, giving more power, result - the new AWD works harder and faster.

The K9-3 AWD operates an extensive range of specialised Dingo attachments. For more information on the available attachments, please see our attachments brochure or visit www.dingo.com.au

FEATURES & BENEFITS OF THE K9-3 AWD

Adaptability

The Dingo has a unique ability to be adapted to suite your individual needs. Whether you require wheels or tracks, buckets or trenchers, in a minimal amount of time the Dingo can be transformed easily to suit the job that it's required for.

4 Wheel Motors

Dingo Equipment Australia pioneered the technology that lead to the production of the first ever mini digger with 4 motors and no mechanical chain drive system. The latest edition to the Dingo pack, the K9-3 AWD also features full hydraulic drive to each wheel, easy access to the wheel motors, and no maintenance or adjustment to drive chains.

Increased Hydraulic Flow & Pressure (Diesel Models)

With the new generation of Perkins and Cat enhanced technology tier 3 diesel engines, the K9-3 AWD is now able to deliver more hydraulic flow than ever before. This means greater ground speed and more efficient attachment operation.

Safety Hydraulic Relief Valves

Compensates for the greater pressure, and prevents unsafe overloading of the system.

Service Intervals

Improved engineering, hydraulic design and filtration allows the K9-3 AWD hydraulic service interval to be extended to a massive 1000hr. Effectively lowering the cost of ownership and ensuring the K9-3 AWD is a more affordable option.

2 Pump Hydraulic System

A standard feature on all Dingo's is the unique "Tandem Pump" hydraulic system which improves oil efficiency, directs the flow and power to where they are needed most, and prolongs duty cycle, enabling the Dingo to work for extended periods.

Rupture Resistant Plastic Fuel Tank

Rota moulded plastic fuel tanks are robust as well as spark and rust resistant. First introduced into the automotive industries in the 1970's, these tough plastic tanks have now become an accepted earthmoving equipment industry standard.

Sealed Roller Bearings

The K9-3 AWD encompasses sealed roller bearings and Teflon bushes in the joints for a low maintenance, no mess joint. No mess, no fuss equal's lower ownership cost.

Serviceable Hydraulic Tank

Access to the hydraulic tank on all Dingo models, allows the hydraulic system to be thoroughly cleaned in the manufacture process, and ease of accessibility to the internal systems.

2 Lift Rams

Ensuring stable lifting, with no excess pressure on the chassis or arms.

DataDot Theft Prevention System

Tiny dots laser-etched with a unique number which is sprayed onto the Dingo. The random number is tracked on the Data Dot system.

STANDARD FEATURES

- 2 Pump Hydraulic System
- Auxiliary Hydraulic Outlet
- Flow Controller
- AWD System
- Heavy Duty Air Cleaner & Pre Cleaner
- Hard Wearing Durable Powder Coat Finish
- Hard Wearing Dingo Tyres
- DataDot Theft Prevention System
- Quick Hitch System
- Easy Soft Touch Operator Controls

SAFETY FEATURES

- Solid Operating Platform
- Machine Stability
- Safety Hydraulic Relief Valve
- Rupture Resistant Plastic Fuel Tank
- Low Engine Noise
- Engine Shut-Off Roll Over Protection (Mercury Switch) *optional feature
- Auxiliary Hydraulic Shut-Off *optional feature
- Catalytic Converter to Reduce Emissions *optional feature

OPTIONAL FEATURES TO CUSTOMISE YOUR MACHINE

- Gas Conversion - Petrol Models
- Level Lift
- Reverse Buzzer
- Light Front & Rear
- Rotating Beacon
- Traction Options for All Conditions Including Tracks, Narrow Wheels or Solid
- Spare Wheel Bracket

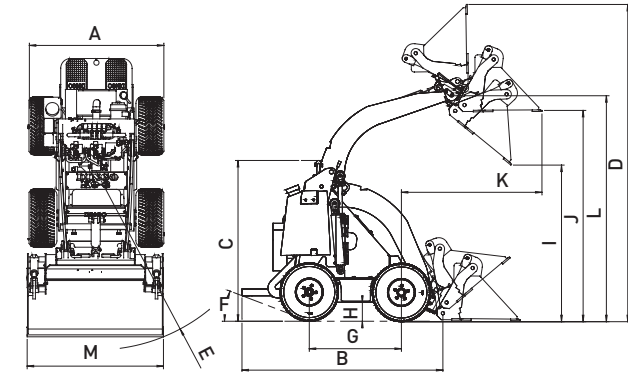

Engine

Make

Power

Performance

Hydraulic Pumps

Pump Sizes

Relief Pressure (Drive)

Relief Pressure (Aux)

Hydraulic Pump Output

Travel Speed (with overdrive)

Rate Lift Capacity

Wheel Motors

Auxiliary Hydraulic Outlets

Dimensions

A. Overall Width

B. Overall Length

C. Overall Height

D. Maximum Operating

Height with 4 in 1 Bucket

E. Turning Radius with

4 in 1 Bucket

F. Angle of Departure

G. Wheel Base

H. Ground Clearance

I. Dump Height Std Bucket

J. Dump Height with

4 in 1 Bucket

K. Reach Fully Raised

4 in 1 Bucket

L. Height to Hinge Pin

M. Machine Width with

4 in 1 Bucket

Hydraulic Reservoir

Machine Mass

Warranty

Engine Warranty

Product Warranty

K9-3 AWD

Vanguard (petrol) | Perkins (Diesel)

Cat

23HP | 20HP / 15kW

2 pumps

9 & 3 cc | 11 & 3 cc

220 bar (3200psi)

206 bar (3000psi)

43 l/min | 47 l/min

0-8.8 km/h | 0-9.5 km/h

SWL: 250 kg

MWL: 500 kg

4 X 29 cu in

1

880mm - 1050mm

1565mm

1200mm

2080mm

1300mm

20°

710-800mm

135mm - 175mm

1240mm

1750mm

600mm

1680mm

1050mm

60L

745kg (approx) | 825kg (approx)

2 Years ^{UNLIMITED*} | 3 Years/1000hrs*

3 Years / 1000hrs*

* Warranty conditions apply.



For more information call **1300 4 DINGO**
visit **WWW.DINGO.COM.AU**



Branches located throughout Australia

© Dingo Australia - March 2010

Specifications & design are subject to change without notice. Specifications may vary and may be approximate.