



MVH-R60



MVH-120GR/GH



MVH-150GR/GH/D



MVH-206D/DS



MVH-406DS



MVH-502DSB

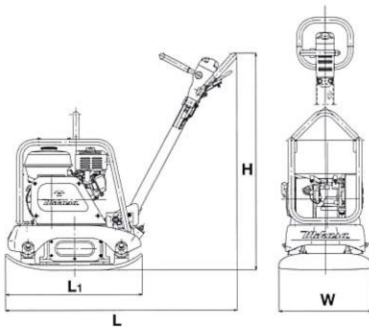

OPTION



Extension Plate

	width(mm)	weight(1set:kg)	set
for MVH-306, 406,502	75	17	1set
	150	23	(2pcs)



MVH-R60 Water tank (8.5ℓ)

model	dimensions	plate size	vibrating frequency	centrifugal force(max.)	max. traveling speed	limited gradeability (max)	power source
MVH-R60	H : 880mm L : 886mm WT : 68/69kg	W : 350mm L1 : 480mm	100Hz (6,000V.P.M)	15.0kN (1,530kgf)	25m/min	35%	Honda GX120 max.output 2.6kW(3.5PS) Robin EX13 max.output 3.2kW(4.3PS)
MVH-120 GR/GH	H : 900mm L : 1,030mm WT : 118/116kg	W : 400mm L1 : 585mm	100Hz (6,000V.P.M)	22.5kN (2,300kgf)	23m/min	35%	Robin EH17-2D max.output 3.7kW(5.0PS) Honda GX160 max.output 3.6kW(4.9PS)
MVH-150 GR/GH/D	H : 920mm L : 1,130mm WT : 164/150/ 150kg	W : 430mm L1 : 700mm	90Hz (5,400V.P.M)	27.0kN (2,750kgf)	25m/min	35%	Robin EH25-2D max.output 5.9kW(8.0PS) Honda GX200 max.output 4.1kW(5.6PS) Robin DY23-2D max.output 3.7kW(5.0PS) diesel engine
MVH-206 D/DS	H : 1,100mm L : 1,380mm WT : 224/238kg	W : 500mm L1 : 720mm	87Hz (5,200V.P.M)	35.0kN (3,570kgf)	23m/min	35%	Yanmar L70N max.output 4.9kW(6.7PS) diesel engine
MVH-207 GH/D/DS	H : 1,100mm L : 1,380mm WT : 214/230/ 244kg	W : 600mm L1 : 720mm	87Hz (5,200V.P.M) 84Hz (5,040V.P.M)	35.0kN (3,570kgf) 32.9kN (3,350kgf)	22m/min	35%	Honda GX240 max.output 5.3kW(7.2PS) Yanmar L70N max.output 4.9kW(6.7PS) diesel engine
MVH-306 DS	H : 970mm L : 1,570mm WT : 336kg	W : 445mm (595mm) (745mm) L1 : 860mm	73Hz (4,400V.P.M)	45.0kN (4,600kgf)	23m/min	35%	Yanmar L70N max.output 4.9kW(6.7PS) diesel engine electric start
MVH-406 DS	H : 930mm L : 1,610mm WT : 410kg	W : 500mm (650mm) (800mm) L1 : 900mm	73Hz (4,400V.P.M)	50.0kN (5,100kgf)	23m/min	35%	Yanmar L100N max.output 7.4kW(10.0PS) diesel engine electric start
MVH-502 DSB	H : 950mm L : 1,680mm WT : 550kg	W : 550mm (700mm) (850mm) L1 : 900mm	67Hz (4,000V.P.M)	61.7kN (6,300kgf)	23m/min	35%	Hatz 1D81S max.output 9.7kW(13.2PS) diesel engine electric start

Weight includes weigh of machine, lubricants, 50% of fuel and 50% of water in case with water tank option.  
Features and specifications are subject to change without notification.