



Bobcat®

T 2566





Bobcat®

T 2566

RATED CAPACITY	2500 kg
LIFTING HEIGHT	6450 mm
MAXIMUM REACH	4050 mm
CAPACITY	at max. height 2200 kg
	at max. reach 900 kg
CROWDING FORCE	3200 daN
WEIGHT (unladen)	4990 kg



FUNCTION TIME

	Seconds
Lift speed	5.0
Lower speed	2.5
Telescope in	6.5
Telescope out	7.0
Crowding	3.0
Dumping	2.5



4X4X4 MOTION

4 EQUAL DRIVE AND STEERING WHEELS
Mobility and motion through 2 automatic steering axles 2 WD - 4WD - CRAB



TYRES

Standard	400/70x20	140B
Option	15.0-55x17	

THE STEERING MODE IS SELECTED FROM THE OPERATOR'S CAB



BRAKES

ENGINE BRAKING Hydrostatic
MAIN BRAKES Immersed disk brakes acting on both axles
PARKING AND EMERGENCY BRAKES Negative mechanical acting on both axles



ENGINE

TYPE	PERKINS 1004.42 and 1004.40T Diesel 4 cylinder / 3990 cc DIRECT INJECTION WATER COOLING		
POWER AT 2200 RPM DIN 6271	HP	kW	
ATMO	80	59	
TURBO	106	78	
MAX. TORQUE	ATMO	290 Nm at 1400 rpm	
	TURBO	394 Nm at 1400 rpm	



HYDROSTATIC TRANSMISSION

2 DRIVING MODES: aggressive/smooth
2 SPEED RANGES: forward and reverse

Working	FWD and REV	0 to 7 km/h
Travel	FWD and REV	0 to 30 km/h

- Accelerator pedal for automatic gear variation
- Single pedal for inching and braking



HYDRAULIC SYSTEM

GEAR TYPE PUMP	
WORKING PRESSURE	220 bar
FLOW RATE	91 l/min



CAPACITIES

HYDRAULIC SYSTEM	65 l	
FUEL TANK	120 l	
AXLES AND REDUCTION GEARS	16 l	
ENGINE OIL	ATMO 8 l	TURBO 8 l



ATTACHMENTS

730-1300 l digging and reclaim bucket - Pallet-forks with or without side shift carriage - 4 in 1 bucket - Multibuckets - Crane jib - Dozer blade - Concrete bucket (mechanical or hydraulic opening) - Trailer hook

LIFTING CAPACITIES

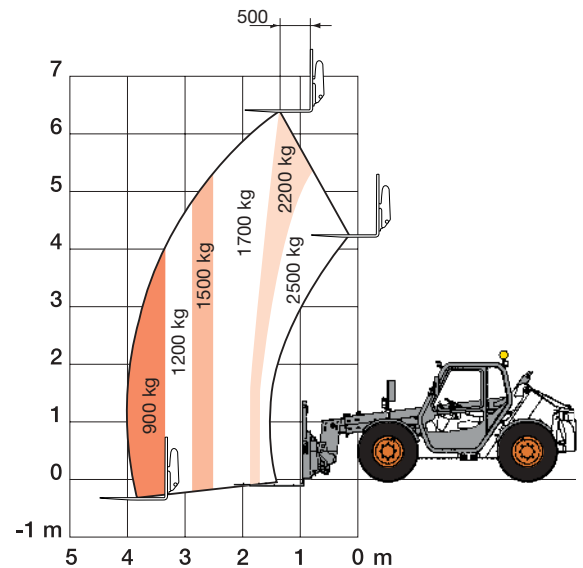

DIMENSIONS

All dimensions are in mm.

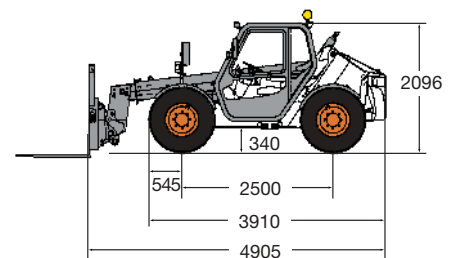
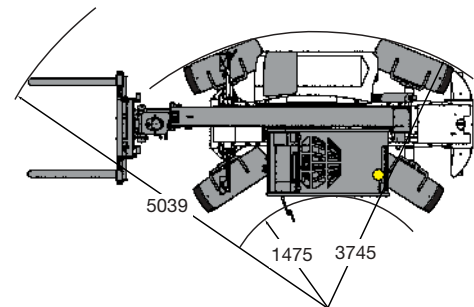
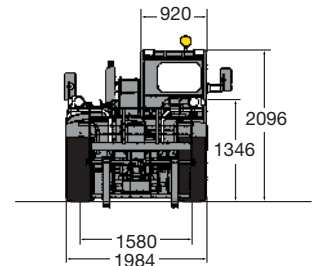

Get more info from your dealer.



BOBCAT EUROPE

J. Huysmanslaan, 59 - B - 1651 LOT Belgium
© +32 (0)2 371 68 11 - Fax +32 (0)2 371 69 59