

Operator's and Safety Handbook



Zebra 16 with outriggers



DISTRIBUTOR'S STAMP



FOREWORD

This manual has been compiled to assist to properly use and maintain your Zebra 16 self-propelled work platform.

Take the time to carefully read and familiarise yourself with its content. Once you have read and understood all sections, keep this manual in the manual storage box provided to this effect in the platform.

The information in this manual does not, in any case, replace community, state, local regulations or safety instructions or insurance policy requirements.

Due to constant improvements made to its products, **ATN** reserves the right to alter their specifications and equipment without prior notice.

WARNING SYMBOLS AND SAFETY TERMS



These symbols alert the user to possible risks of injury and invite them to consult the operator and safety manual. The safety instructions which follow these symbols must be respected to avoid any risk of serious or fatal injury.



DANGER



INDICATES A DANGEROUS SITUATION WHICH MAY LEAD TO SERIOUS OR FATAL INJURIES IF THE SAFETY INSTRUCTIONS ARE NOT RESPECTED.



CAUTION



INDICATES A PROCEDURE OR OPERATION TO BE RESPECTED TO THE LETTER TO AVOID ANY RISK OF DAMAGES TO THE MACHINE.

- NOTE-

These are generally remarks relating to a procedure or important condition for using the machine.

**DANGER**

DO NOT USE THIS MACHINE IF YOU HAVE NOT BEEN PROPERLY TRAINED TO ITS SAFE OPERATION. TRAINING INCLUDES KNOWLEDGE OF YOUR EMPLOYER'S WORK REGULATIONS, THE INSTRUCTIONS IN THIS MANUAL AND THE REGULATION IN FORCE FOR THIS TYPE OF MACHINE.

AN UNTRAINED OPERATOR PUTS HIMSELF AND OTHERS AT RISK OF DEATH OR SERIOUS INJURIES.

**DANGER**

NEVER EXCEED THE PLATFORM'S RATED CAPACITY.
THE LOAD MUST BE EVENLY DISTRIBUTED ACROSS THE WORK PLATFORM FLOOR.
DO NOT RAISE THE PLATFORM OR MOVE WITH THE PLATFORM RAISED ON INCLINES, HILLY OR SOFT SURFACES.
ALL 4 WHEELS MUST REMAIN IN PERMANENT CONTACT WITH THE GROUND.



FOR THE ATTENTION OF THE CUSTOMER / USER

If this platform is involved in an accident, please contact your distributor immediately and provide them with all the details of the accident. If you do not know who your distributor is, or cannot inform them, please contact:



Tel: 33 (0)5 53 79 83 20

Fax: 33 (05) 53 79 96 90

Address: Lieu-Dit Bacqué, rue André Thévet, 47400 Fauillet, France



A.T.N. - S.A.

Head office: Lieu Dit Bacqué – Rue André Thevet, 47400 Fauillet, France
Administrative and accounting: Lieu Dit Bacqué – Rue André Thevet, 47400 Fauillet, France
RCS Agen 429 807 597 – Code APE/ 2822Z – SIRET 429 807 597 00068 - Capital 57900 €

EC CONFORMITY DECLARATION

The manufacturer: A.T.N. declares that the machine designated below:

Denomination PEMP (Mobile Elevating Work Platform)
Function Elevation of people for work at heights
Type Diesel Elevating platform with articulated arms (Group B – Type 3)
Model and commercial designation **ZEBRA 16**
Serial number **Z16xxxxx**

meets all of the relevant provisions in the appendix at the end of the 1st chapter in book III of the fourth section of the employment code (Machine Directive 2006/42/CE of 17th May 2006), also meets other relevant provisions such as EMC directive 2004/108/CE of 15th December 2004 and the noise emission directive 2000/14/CE of 8th May 2000.

This machine also conforms to standard NF EN280.

The EC type certificate has been awarded by:
APAVE
13 à 17 rue Salneuve
75854 PARIS CEDEX 17
Under the reference:
0060/ 5253/ 760/ 09/13 / 0002 Ext N°002 / 06/16



TABLE OF CONTENTS

Section 1. GENERAL DESCRIPTION +	8
1.1. DESCRIPTION	8
1.2. CHARACTERISTICS - DIMENSIONS	9
Section 2. SAFETY INSTRUCTIONS	14
2.1. GENERAL INFORMATION	14
2.2. CONTROLS AND INDICATORS	14
2.3. OUTRIGGERS	16
Section 3. Schematics	17
3.1. ELECTRIC SCHEMATIC	17
3.2. HYDRAULIC SCHEMATIC	19
NOTES	21



Section 1. GENERAL DESCRIPTION +

1.1. DESCRIPTION

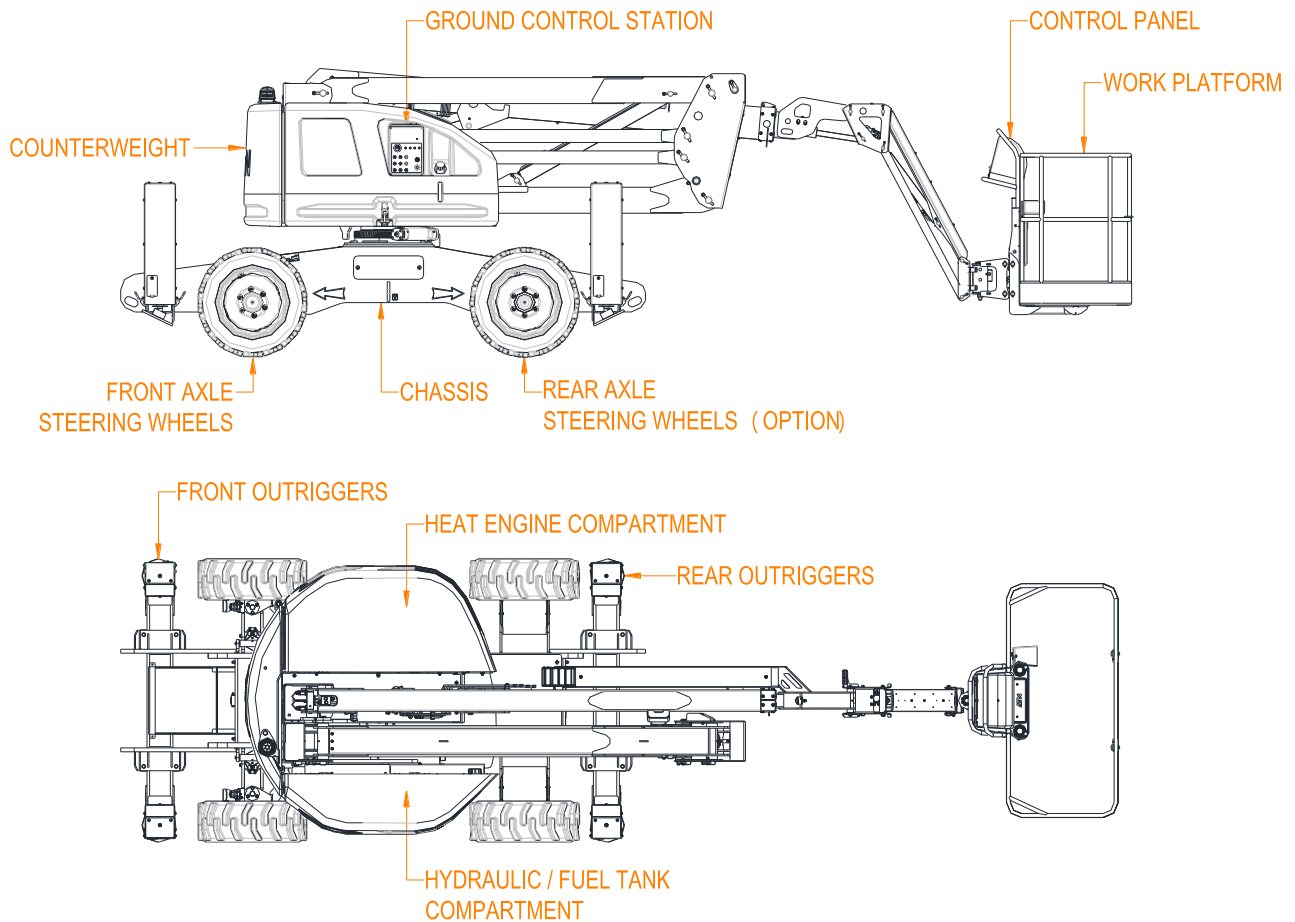



1.2. CHARACTERISTICS - DIMENSIONS

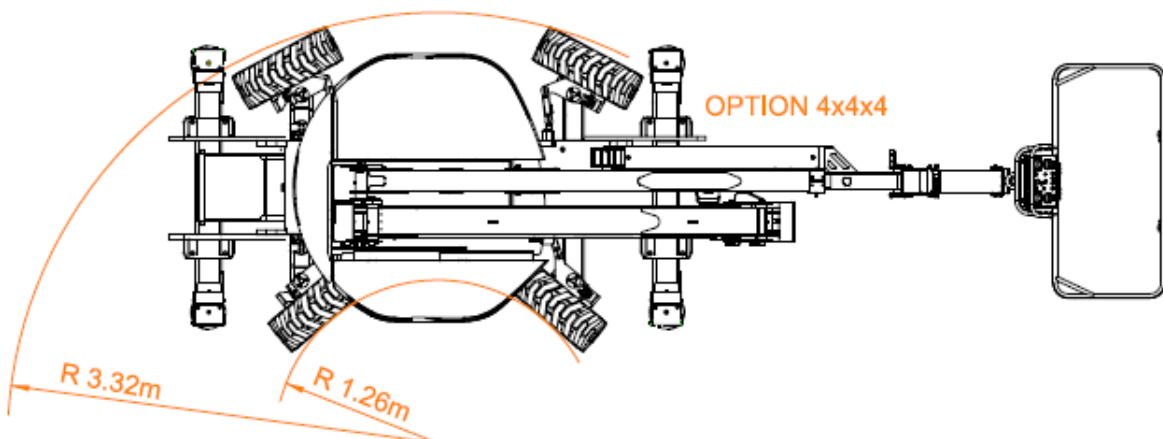
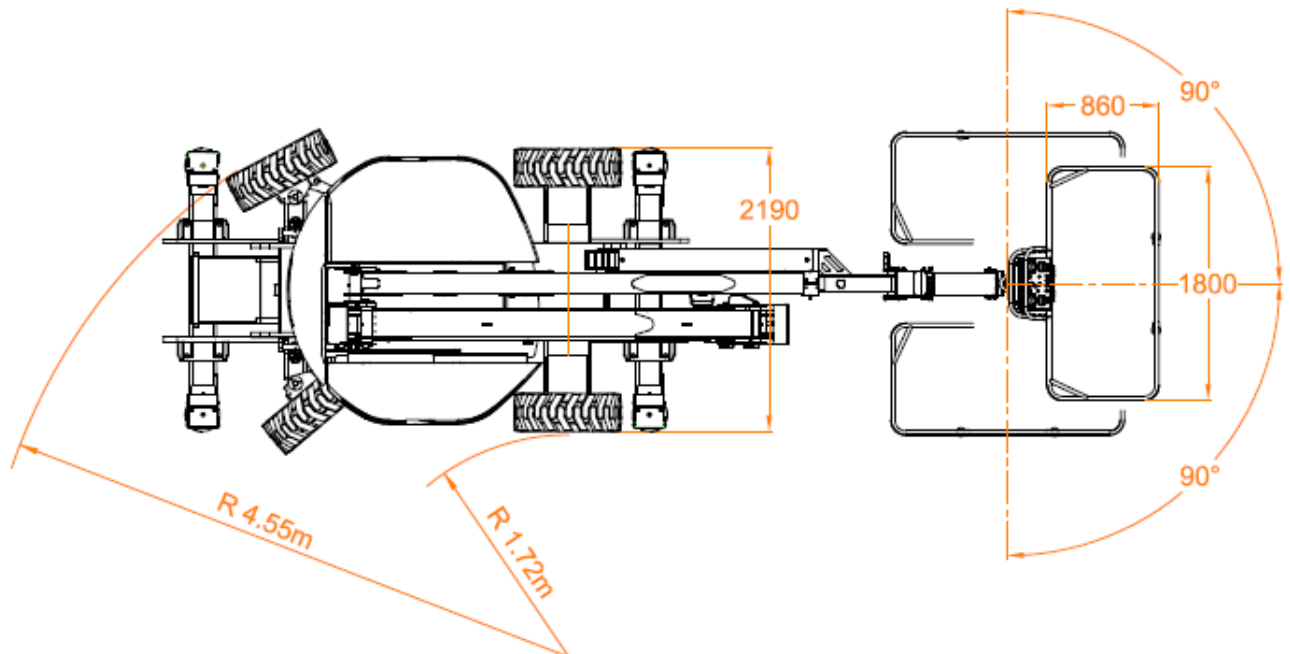
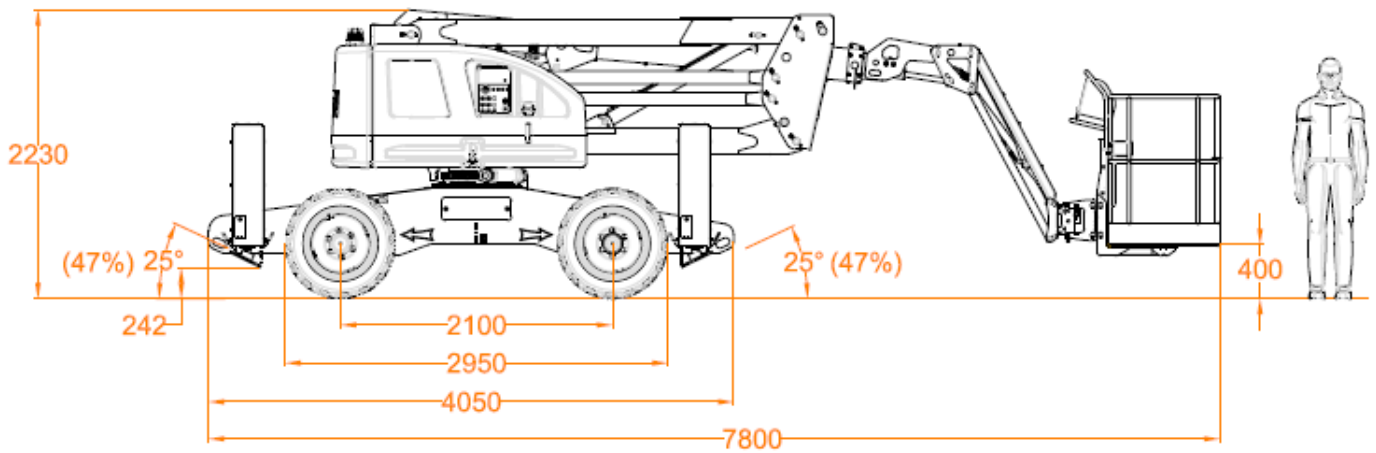

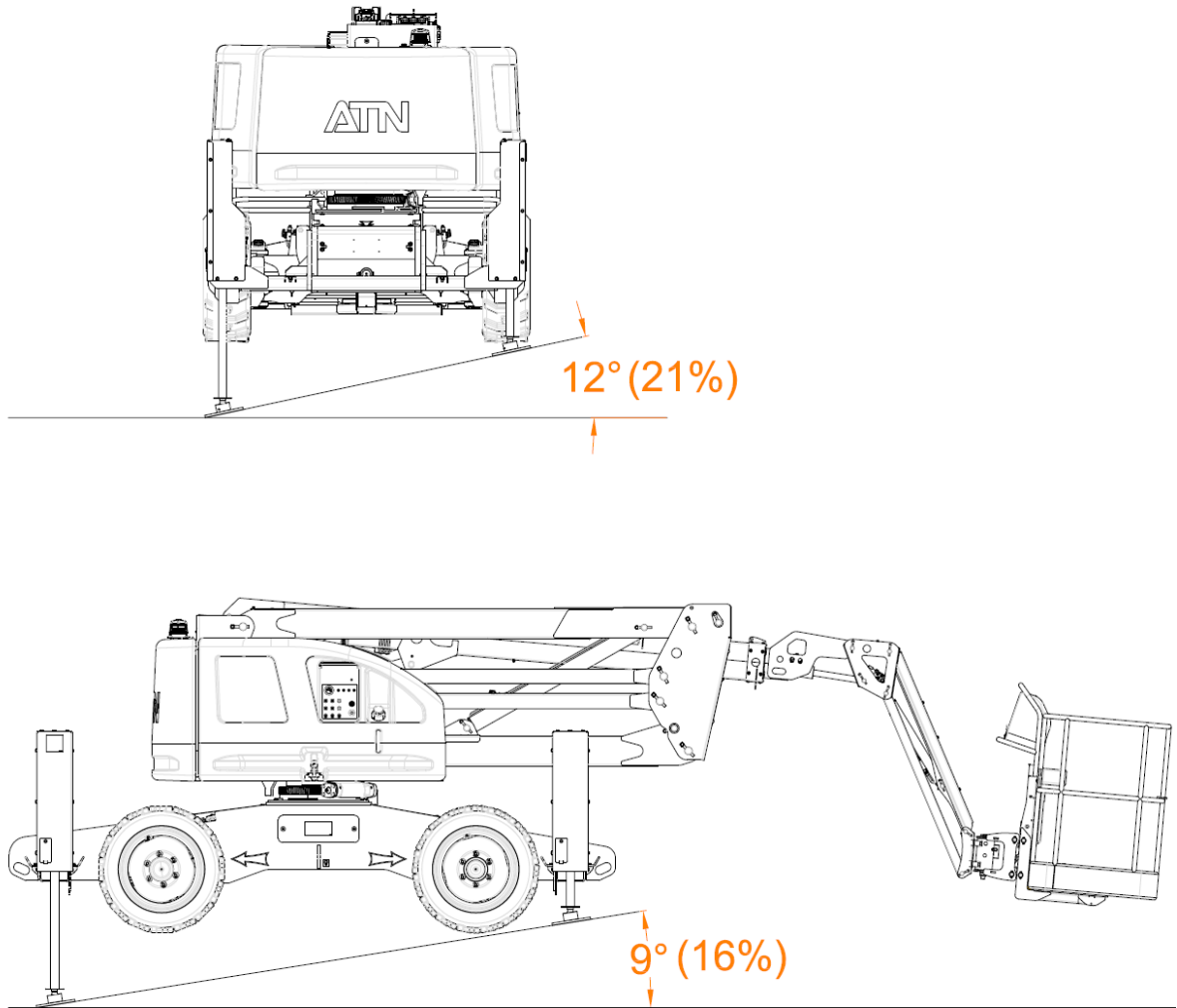

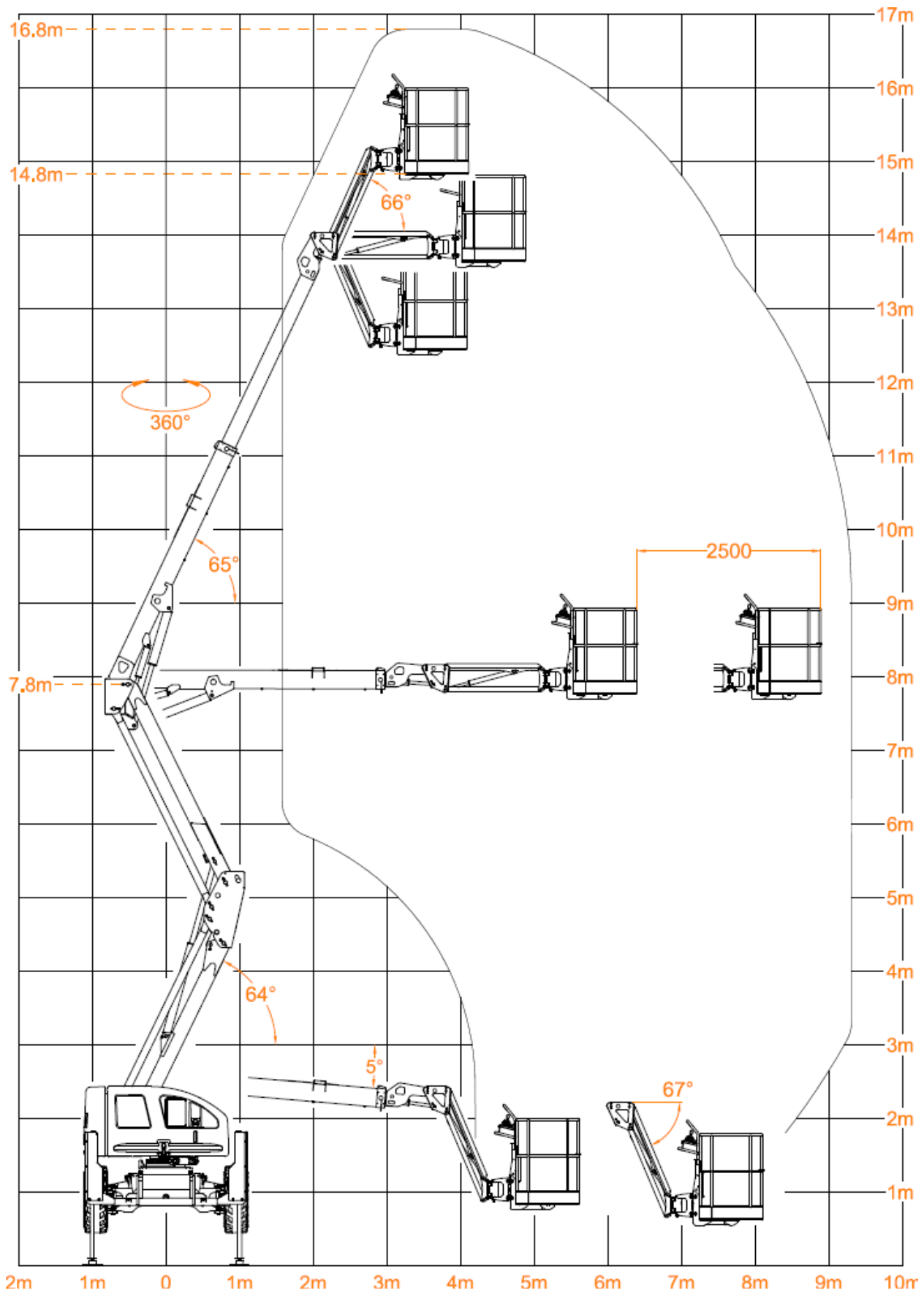



CHARACTERISTICS		Zebra 16 with outriggers
Maximum working height		16.80 m
Max floor height		14.80 m
Min floor height		0.40 m
Max outreach (on axis)		8.90 m
Max working reach (on axis)		9.40 m
Structure orientation		360° (Non continuous)
Work platform rotation		2x 90°
Work platform dimensions		0.86 x 1.80 m
Max number of people on the platform		2
Platform capacity		230 kg
Maximum allowable wind		12.5 m/s (45 km/h)
Maximum manual force		400 Newton
Maximum tilt (on wheels)		5°
Maximum tilt (on outriggers)		1°
Maximum allowable slope		43%
Overall length (transport position)		7.70 m
Longitudinal levelling capacity		9 Degrees (16%)
Side levelling capacity		12 Degrees (21%)
Overall length (storage position)		5.69 m
Overall Width		2.19 m
Overall height (transport position)		2.26 m
Wheelbase		2.10 m
Ground clearance		0.40 m
Oscillating axle travel		0.23 m (14°)
Number of driving wheels		4
Number of steering wheels		2
Tyres (solid tyres)	Standard	830x285(530)
	Option	36x14-20
Turning radius	Inside (2 steering wheels)	1.72 m
	Inside (4 steering wheels)	1.26 m
	Outside (2 steering wheels)	4.55 m
	Outside (4 steering wheels)	3.32 m
Travel speed	Transport position	6km/h
	With platform elevated	0.85km/h
Empty weight	Standard	8050kg
Empty weight	4x4x4	8200kg
Load on one wheel (*)	Effort	4 200 daN
	Contact pressure	14.5 kg/cm ² (1422 kPa)
Load on one outrigger (*)	Effort	3561 daN
	Contact pressure	6.8 kg/cm ² (6681 kPa)
<p>(*): The floor load values indicated may vary depending on the configuration/position of the machine. an adequate safety margin with respect to these values should always be kept.</p>		
<p>The weighted acoustic pressure level A on the platform's control station is dB(A). The weighted acoustic power level emitted by the machine (LWA) is 104 dB (test method according to European directive 2000/14/CE relating to noise emissions in the environment of equipment intended to be used outside buildings – Appendix III, Section B, Points 0 and 1).</p>		
<p>The total value of the vibrations to which the hand-arm system is exposed does not exceed 2.5m/s². The average maximum quadratic value weighted by the acceleration frequency to which the whole body is exposed does not exceed 0.5m/s².</p>		
<p>Due to constant improvements made to its products, ATN reserves the right to alter their specifications and equipment without notice.</p>		



MOVEMENT DURATIONS			Zebra 16
Arm 1	Rise	Idle	29 to 32 seconds
		High regime	17 to 20 seconds
	Descent	Idle	24 to 27 seconds
		High regime	21 to 24 seconds
Arm 2	Rise	Idle	25 to 28 seconds
		High regime	14 to 17 seconds
	Descent	Idle	17 to 20 seconds
		High regime	13 to 17 seconds
Arm 3	Rise		16 to 19 seconds
	Descent		18 to 21 seconds
Telescope	Out	Idle	30 to 33 seconds
		High regime	17 to 20 seconds
	In	Idle	18 to 21 seconds
		High regime	16 to 19 seconds
Orientation (end to end)			110 to 120 seconds
Rotation (end to end)			10 to 15 seconds
<p>Note: The movement speeds may vary according to the telescope position, the adjustment of the limit switches and the adjustment of the load holding valves.</p>			



Section 2. SAFETY INSTRUCTIONS

2.1. GENERAL INFORMATION

2.1.1 INSPECTION OF THE WORK PLACE

- Ensure the ground can support the load of the wheels or of the outrigger pads.

2.1.2 TIPPING HAZARDS

- Do not use the outriggers on soft, hilly or loose surfaces. Always ensure the pads lay flat on firm grounds before raising the work platform.

2.2. CONTROLS AND INDICATORS

2.2.1 GROUND CONTROL STATION

Outrigger control is not authorised from the ground control station.

2.2.2 WORK PLATFORM CONTROL STATION

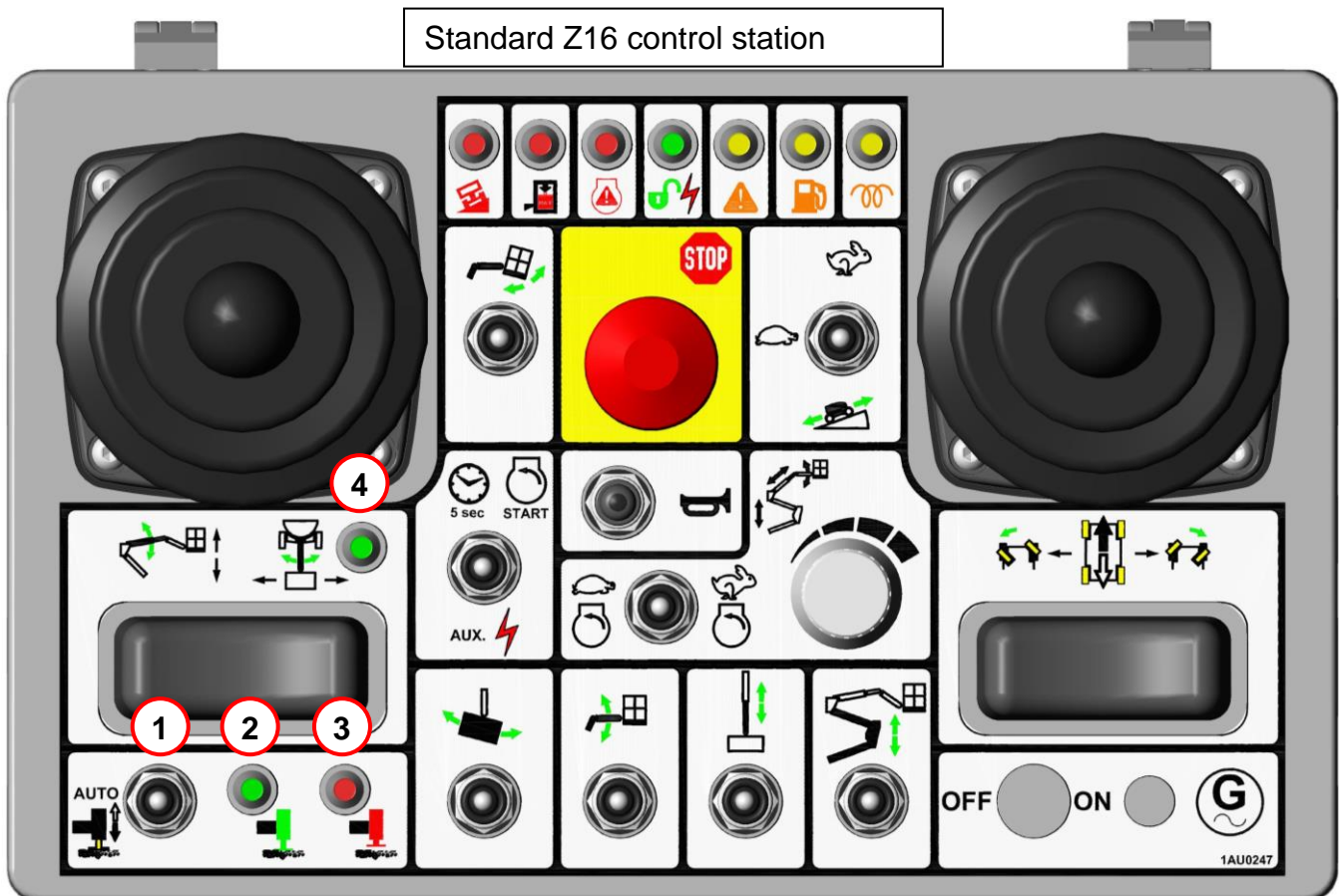

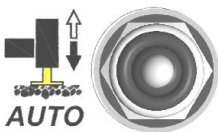
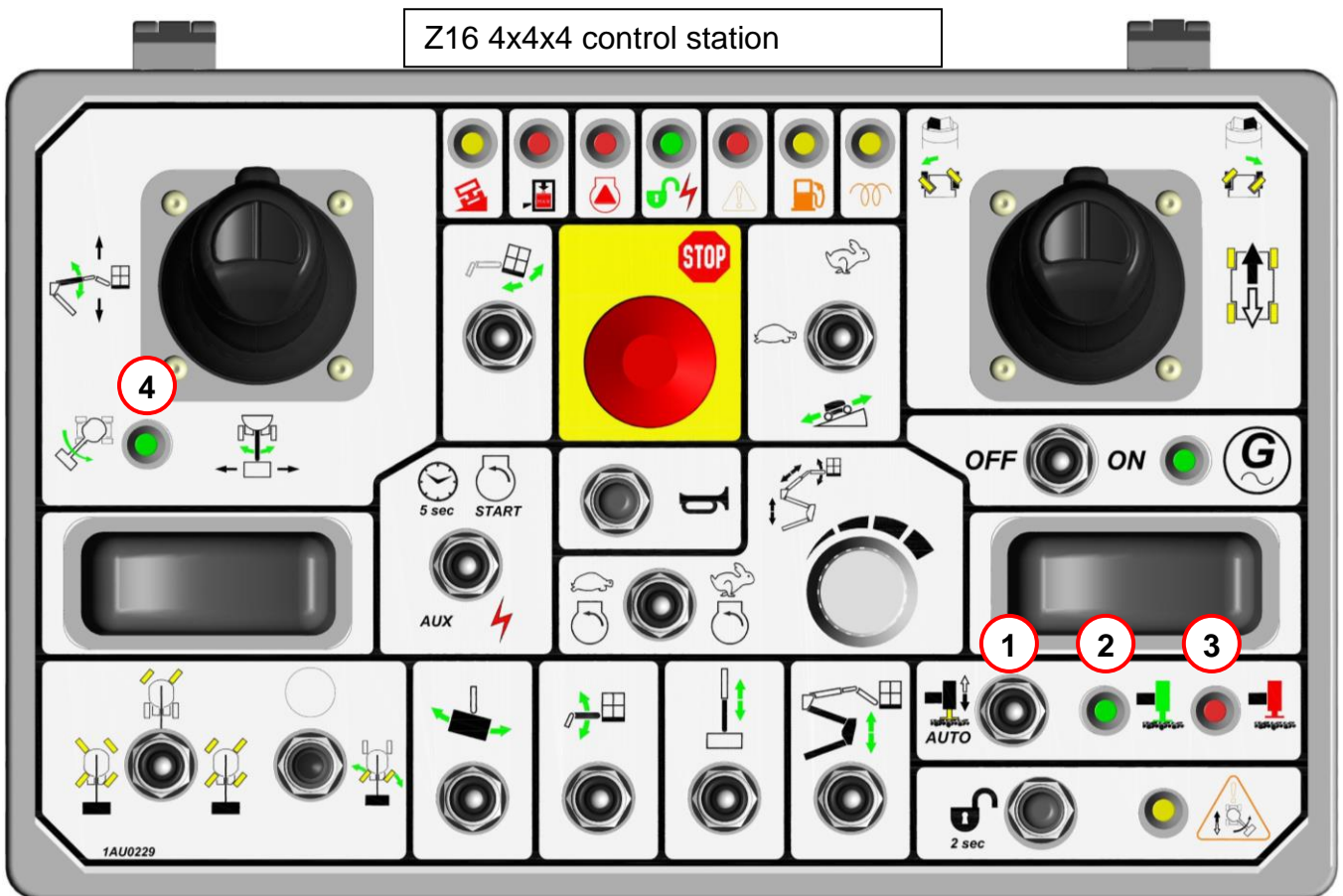

1- Outrigger Extension/Retraction control

The platform must be lowered and the pedal depressed. Push the button forwards to extend the outriggers and actuate the automatic levelling. Pull the button rearwards to retract the outriggers.

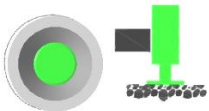

2- Outrigger ground contact indicator

This indicator flashes when the automatic levelling mode is actuated as well as during the movement of the outriggers. This indicator is on steady when all four outriggers contact the ground.

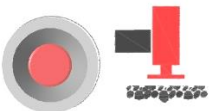

3- Outrigger position indicator

This indicator is on steady:

- During the outrigger movement as long as they do not contact the ground.
- When the four outriggers are not completely retracted.
- When at least ONE OF THE OUTRIGGERS DOES NOT OR NO LONGER CONTACT THE GROUND FIRMLY.

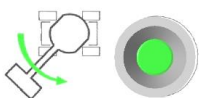

4- Structure rotation indicator

During the rotation of the structure a cam stops the jib 1 before it collides with one of the outrigger cylinder. This indicator indicates the jib 1 is raised enough (approx 10°) to authorise a continuous rotation above the outrigger cylinders.



2.3. OUTRIGGERS

The machine is fitted with four outrigger cylinders allowing the chassis to be levelled before raising the work platform.

The outrigger control is only possible when the machine is lowered.

The chassis is always levelled in automatic mode.

- **Automatic levelling**

- 1- Select the platform control station and start the heat engine.
- 2- Depress the enable pedal.
 - The green indicator lights up.
- 3- Within 5 seconds, push the switch forward to extend the outriggers:
 - The engine speed increases.
 - The red outrigger position indicator switches on.
- 4- Once the four outriggers contact the ground:
 - The green outrigger ground contact indicator flashes.
 - The engine speed slows down.
 - The levelling sequence starts.
- 5- Keep the switch pushed forward until:
 - The outrigger ground contact indicator is on steady.
 - The tilt indicator switches off.
 - An acoustic signal (2 quick beeps) sounds.

The outrigger movement stops automatically when the chassis is level.

- 6- To retract the outriggers, fully lower the platform then pull the switch backwards.
 - The engine speed increases.
 - As soon as the outriggers no longer contact the ground the red indicator lights up.
 - The outrigger movement stops automatically when they are fully retracted..
 - An acoustic signal (3 quick beeps) sounds
- 7- Drive movements are authorised.

- **Automatic levelling failure**

- 1- Loss of contact with the ground during the automatic levelling sequence.

If an outrigger loses firm contact with the ground:

- The levelling sequence is interrupted.
 - The red indicator for loss of ground contact lights up.
- Check the ground condition and resistance or that there are no objects under the outrigger pads.
 - If need be move the machine on firmer grounds.

Prior to restart a new automatic levelling sequence, the four outriggers must be retracted until none of them contact the ground (system reset).

- 2- Outrigger cylinders reaching the end of their course or tilt aggravation detection.

If the outriggers reach the end of their course before the chassis is level or if the chassis tilt gets worse instead of being corrected: the levelling sequence is interrupted.

- Check the ground condition and surface.
- If need be move the machine to a surface where it will be possible to level the machine.



Section 3. Schematics

3.1. ELECTRIC SCHEMATIC

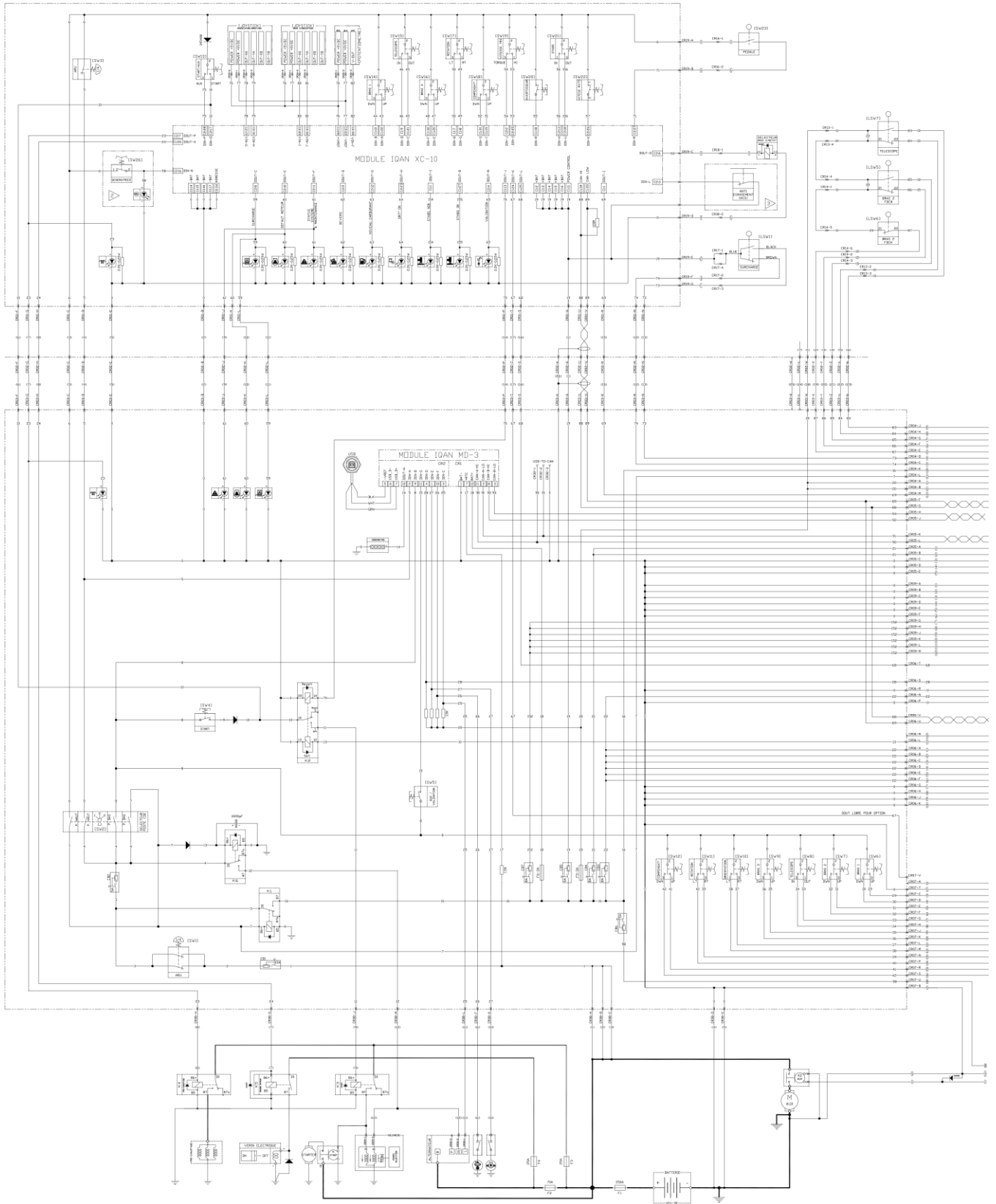

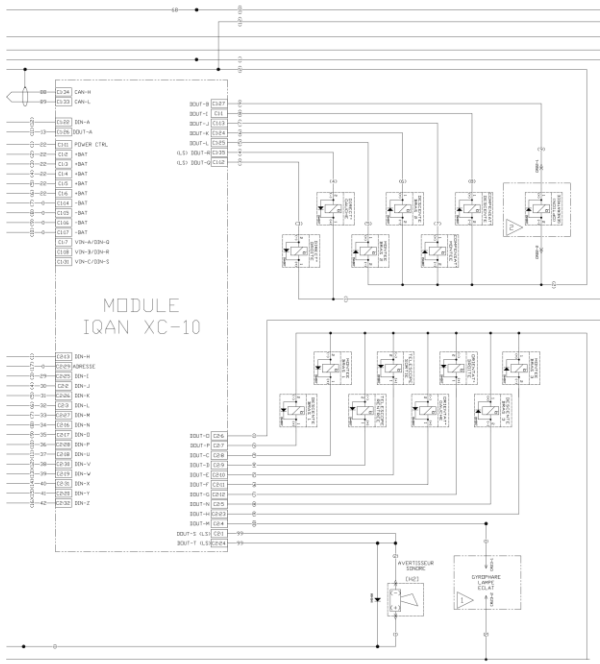
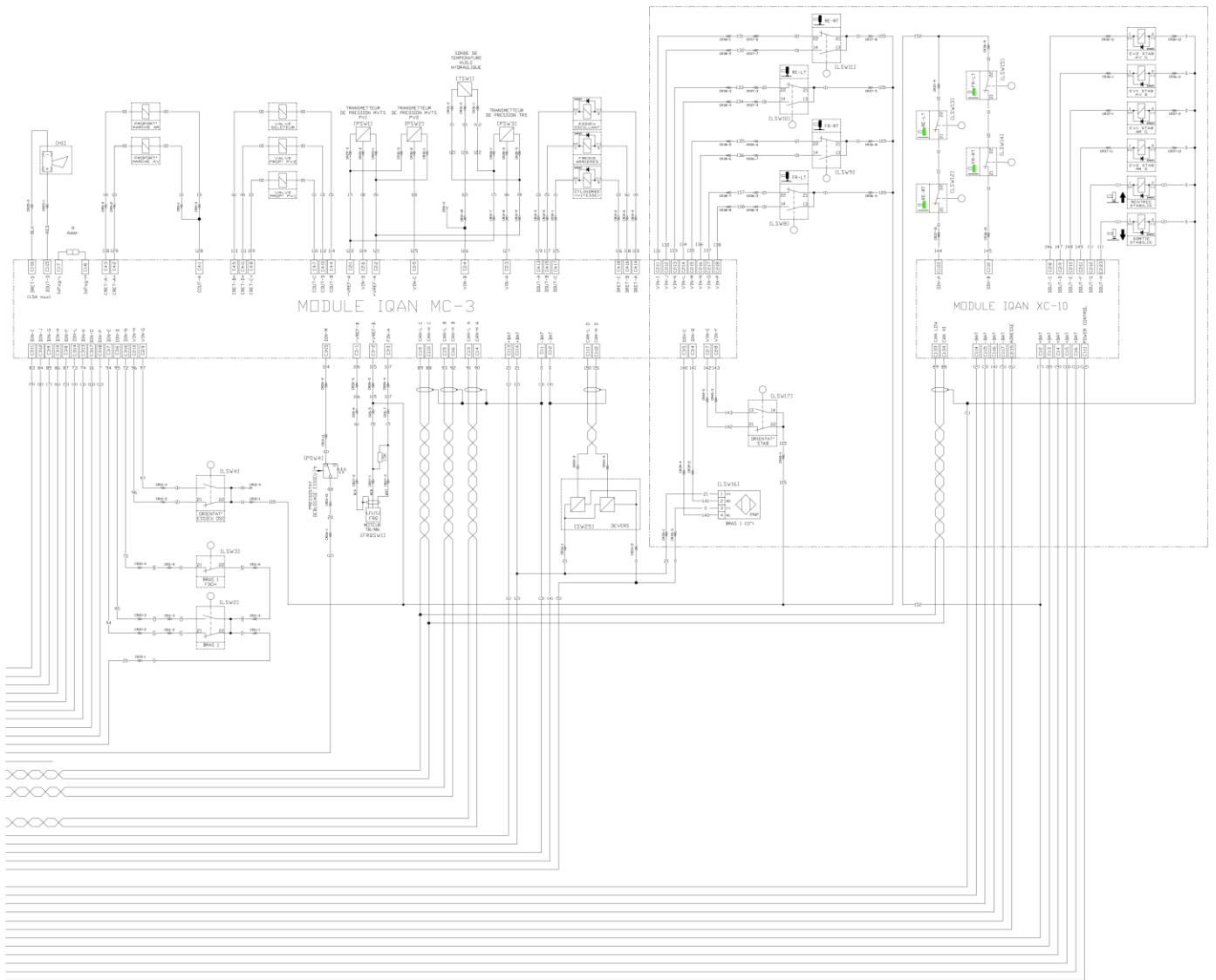



3.2. HYDRAULIC SCHEMATIC

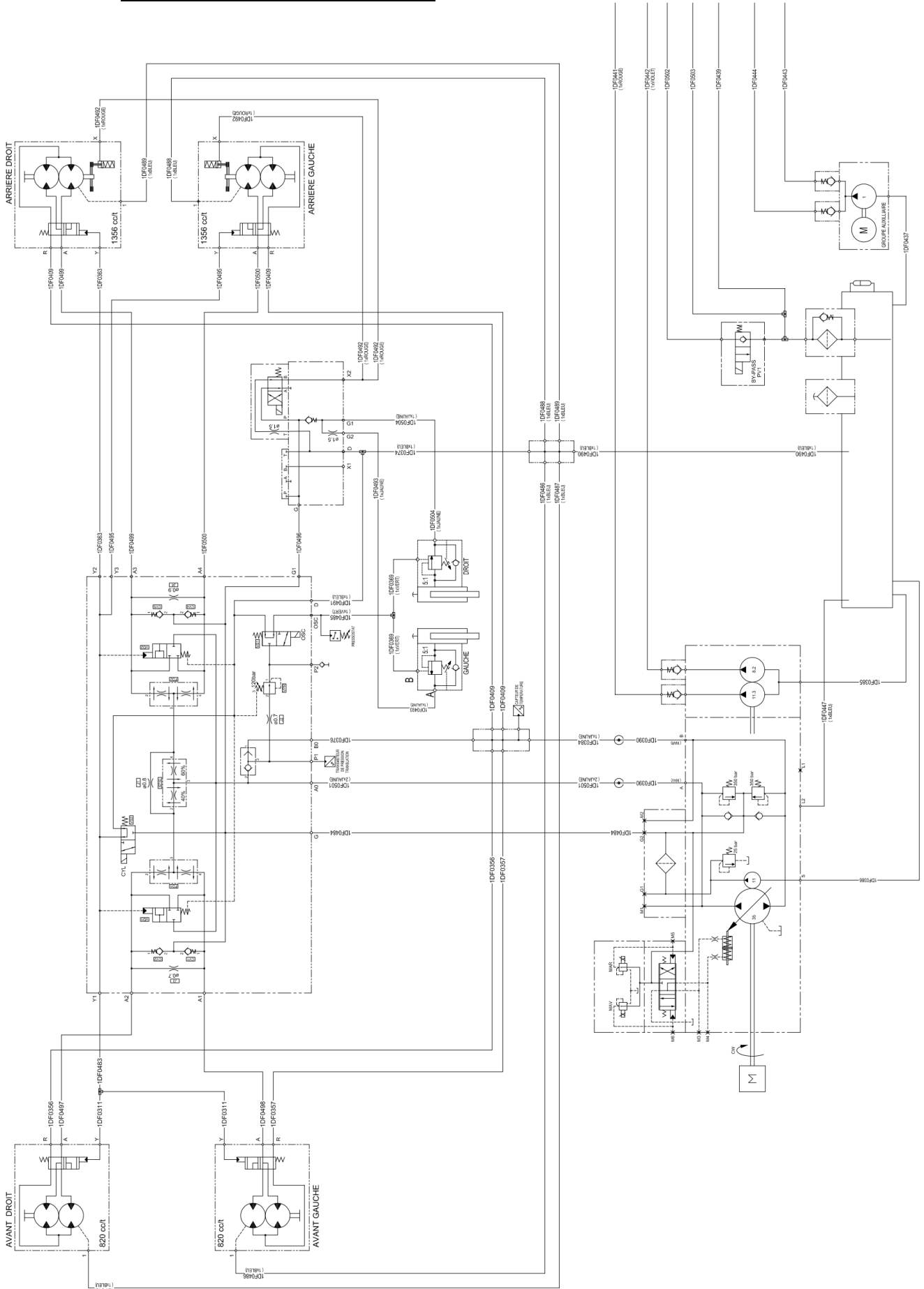

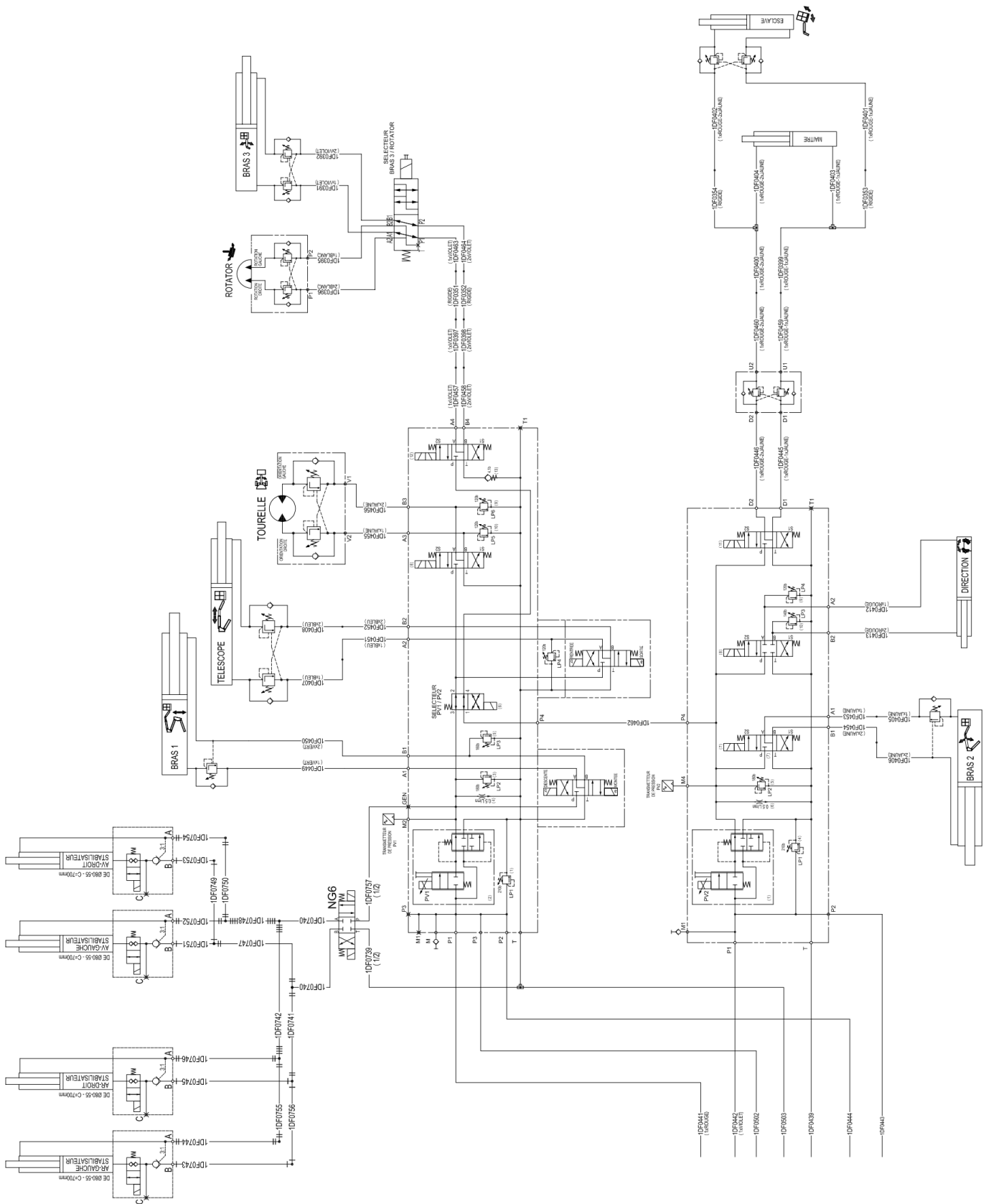



NOTES