



An Oshkosh Corporation Company

Operation and Safety Manual

Original Instructions - Keep this manual with the machine at all times.

Boom Lift Models

800A

800AJ

S/N 0300183034 to

Present

ANSI



3121627

November 5, 2018 - Rev I

NOTE: *This manual also applies to machines with the following Serial Numbers: 0300174954, 0300180871, and 0300181353.*



WARNING

Operating, servicing and maintaining this vehicle or equipment can expose you to chemicals including engine exhaust, carbon monoxide, phthalates, and lead, which are known to the State of California to cause cancer and birth defects or other reproductive harm. To minimize exposure, avoid breathing exhaust, do not idle the engine except as necessary, service your vehicle or equipment in a well-ventilated area and wear gloves or wash your hands frequently when servicing. For more information go to www.P65Warnings.ca.gov.

FOREWORD

This manual is a very important tool! Keep it with the machine at all times.

The purpose of this manual is to provide owners, users, operators, lessors, and lessees with the precautions and operating procedures essential for the safe and proper machine operation for its intended purpose.

Due to continuous product improvements, JLG Industries, Inc. reserves the right to make specification changes without prior notification. Contact JLG Industries, Inc. for updated information.

SAFETY ALERT SYMBOLS AND SAFETY SIGNAL WORDS



This is the Safety Alert Symbol. It is used to alert you to the potential personal injury hazards. Obey all safety messages that follow this symbol to avoid possible injury or death

DANGER

INDICATES AN IMMINENTLY HAZARDOUS SITUATION. IF NOT AVOIDED, WILL RESULT IN SERIOUS INJURY OR DEATH. THIS DECAL WILL HAVE A RED BACKGROUND.

WARNING

INDICATES A POTENTIALLY HAZARDOUS SITUATION. IF NOT AVOIDED, COULD RESULT IN SERIOUS INJURY OR DEATH. THIS DECAL WILL HAVE AN ORANGE BACKGROUND.

CAUTION

INDICATES A POTENTIALLY HAZARDOUS SITUATION. IF NOT AVOIDED, MAY RESULT IN MINOR OR MODERATE INJURY. IT MAY ALSO ALERT AGAINST UNSAFE PRACTICES. THIS DECAL WILL HAVE A YELLOW BACKGROUND.

NOTICE

INDICATES INFORMATION OR A COMPANY POLICY THAT RELATES DIRECTLY OR INDIRECTLY TO THE SAFETY OF PERSONNEL OR PROTECTION OF PROPERTY.

⚠ WARNING

THIS PRODUCT MUST COMPLY WITH ALL SAFETY RELATED BULLETINS. CONTACT JLG INDUSTRIES, INC. OR THE LOCAL AUTHORIZED JLG REPRESENTATIVE FOR INFORMATION REGARDING SAFETY-RELATED BULLETINS WHICH MAY HAVE BEEN ISSUED FOR THIS PRODUCT.

NOTICE

JLG INDUSTRIES, INC. SENDS SAFETY RELATED BULLETINS TO THE OWNER OF RECORD OF THIS MACHINE. CONTACT JLG INDUSTRIES, INC. TO ENSURE THAT THE CURRENT OWNER RECORDS ARE UPDATED AND ACCURATE.

NOTICE

JLG INDUSTRIES, INC. MUST BE NOTIFIED IMMEDIATELY IN ALL INSTANCES WHERE JLG PRODUCTS HAVE BEEN INVOLVED IN AN ACCIDENT INVOLVING BODILY INJURY OR DEATH OF PERSONNEL OR WHEN SUBSTANTIAL DAMAGE HAS OCCURRED TO PERSONAL PROPERTY OR THE JLG PRODUCT.

For:

- Accident Reporting
- Product Safety Publications
- Current Owner Updates
- Questions Regarding Product Safety
- Standards and Regulations Compliance Information
- Questions Regarding Special Product Applications
- Questions Regarding Product Modifications

Contact:

Product Safety and Reliability Department
JLG Industries, Inc.
13224 Fountainhead Plaza
Hagerstown, MD 21742
USA

or Your Local JLG Office
(See addresses on inside of manual cover)

In USA:

Toll Free: 877-JLG-SAFE (877-554-7233)

Outside USA:

Phone: 240-420-2661
Fax: 301-745-3713
E-mail: ProductSafety@JLG.com

REVISION LOG

Original Issue	A - March 20, 2014
Revised	B - April 30, 2014
Revised	C - June 4, 2014
Revised	D - January 5, 2015
Revised	E - June 30, 2017
Revised	F - March 23, 2018
Revised	G - May 30, 2018
Revised	H - June 29, 2018 - Revised Covers, Prop 65
Revised	I - November 5, 2018

SECTION - PARAGRAPH, SUBJECT	PAGE
SECTION - 1 - SAFETY PRECAUTIONS	
1.1 GENERAL	1-1
1.2 PRE-OPERATION	1-1
Operator Training and Knowledge	1-1
Workplace Inspection	1-2
Machine Inspection	1-3
1.3 OPERATION	1-3
General	1-3
Trip and Fall Hazards	1-4
Electrocution Hazards	1-5
Tipping Hazards	1-7
Crushing and Collision Hazards	1-10
1.4 TOWING, LIFTING, AND HAULING	1-11
1.5 MAINTENANCE	1-11
Maintenance Hazards	1-11
Battery Hazards	1-13
SECTION - 2 - USER RESPONSIBILITIES, MACHINE PREPARATION, AND INSPECTION	
2.1 PERSONNEL TRAINING	2-1
Operator Training	2-1
Training Supervision	2-1
Operator Responsibility	2-1
2.2 PREPARATION, INSPECTION, AND MAINTENANCE	2-2
Pre-Start Inspection	2-4
General	2-7

SECTION - PARAGRAPH, SUBJECT	PAGE
2.3 FUNCTION CHECK	2-9
From the Ground Control Station with No Load in the Platform:	2-9
From the Platform Control Station:	2-13
SkyGuard Function Test	2-16
2.4 OSCILLATING AXLE LOCKOUT TEST (IF EQUIPPED)	2-17
SECTION - 3 - MACHINE CONTROLS AND INDICATORS	
3.1 GENERAL	3-1
3.2 CONTROLS AND INDICATORS	3-1
Ground Control Console	3-2
Ground Control Indicator Panel	3-8
Platform Console	3-11
Platform Console Indicator Panel	3-18
SECTION - 4 - MACHINE OPERATION	
4.1 DESCRIPTION	4-1
4.2 BOOM OPERATING CHARACTERISTICS AND LIMITATIONS	4-1
Capacities	4-1
Stability	4-1
4.3 ENGINE OPERATION	4-5
Starting Procedure	4-5
Shutdown Procedure	4-6
Air Shutoff Valve (ASOV) (If Equipped)	4-6
Fuel Reserve / Shut-Off System	4-7

TABLE OF CONTENTS

SECTION - PARAGRAPH, SUBJECT	PAGE	SECTION - PARAGRAPH, SUBJECT	PAGE
4.4 TRAVELING (DRIVING)	4-8	4.12 OSCILLATING AXLE LOCKOUT TEST (IF EQUIPPED) ...	4-19
Traveling Forward and Reverse	4-10	4.13 TOWING	4-19
4.5 STEERING	4-11	4.14 TOW BAR (IF EQUIPPED)	4-19
4.6 PLATFORM	4-11	4.15 DUAL FUEL SYSTEM (GAS ENGINE ONLY)	4-21
Platform Level Adjustment	4-11	Description	4-21
Platform Rotation	4-11	Changing From Gasoline to LP Gas	4-22
4.7 BOOM	4-12	Changing From LP Gas to Gasoline	4-22
Swinging the Boom	4-12	4.16 RE-SYNCHRONIZE UPRIGHT	4-22
Raising and Lowering the Tower Boom	4-13	Releveling Valve	4-22
Raising and Lowering the Main Boom	4-14		
Telescoping the Main Boom	4-14	SECTION - 5 - EMERGENCY PROCEDURES	
4.8 SHUT DOWN AND PARK	4-14	5.1 GENERAL	5-1
4.9 MACHINE SAFETY SYSTEM OVERRIDE (MSSO)		5.2 INCIDENT NOTIFICATION	5-1
(CE ONLY)	4-14	5.3 EMERGENCY OPERATION	5-1
4.10 SKYGUARD OPERATION	4-15	Operator Unable to Control Machine	5-1
SkyGuard	4-15	Platform or Boom Caught Overhead	5-2
SkyGuard - SkyLine	4-15	5.4 EMERGENCY TOWING PROCEDURES	5-2
SkyGuard - SkyEye	4-16	5.5 MACHINE SAFETY SYSTEM OVERRIDE (MSSO)	
SkyGuard Function Table	4-16	(CE ONLY)	5-3
4.11 LIFTING AND TIE DOWN	4-17		
Lifting	4-17	SECTION - 6 - ACCESSORIES	
Tie Down	4-17	6.1 FALL ARREST PLATFORM	6-3
		Safety Precautions	6-3
		6.2 PIPE RACKS	6-3
		Capacity Specifications (Australia Only)	6-4

TABLE OF CONTENTS

SECTION - PARAGRAPH, SUBJECT	PAGE	SECTION - PARAGRAPH, SUBJECT	PAGE
		Tire Replacement.....	7-24
		Wheel Replacement.....	7-24
		Wheel Installation.....	7-25
7.5		PROPANE FUEL FILTER REPLACEMENT.....	7-26
		Removal.....	7-26
		Installation.....	7-27
7.6		PROPANE FUEL SYSTEM PRESSURE RELIEF.....	7-28
7.7		SUPPLEMENTAL INFORMATION.....	7-28

SECTION - 8 - INSPECTION AND REPAIR LOG

FIGURE NUMBER - TITLE	PAGE
2-1. Basic Nomenclature.....	2-5
2-2. Daily Walk-Around Inspection (Sheet 1 of 3)	2-6
2-3. Daily Walk-Around Inspection (Sheet 2 of 3)	2-7
2-4. Daily Walk-Around Inspection (Sheet 3 of 3)	2-8
2-5. Tower Boom Vertical Limit Switch	2-9
2-6. Tower Boom Horizontal Limit Switch	2-10
2-7. Boom Upright Positioning - Correct.....	2-11
2-8. Boom Upright Positioning - Incorrect.....	2-12
3-1. Ground Control Console	3-3
3-2. Ground Control Console with Machine Safety System ... Override (MSSO) (CE Only).....	3-4
3-3. Ground Control Indicator Panel	3-9
3-4. Platform Control Console	3-12
3-5. Platform Console Indicator Panel	3-19
4-1. Position of Least Forward Stability.....	4-2
4-2. Positions of Least Backward Stability (Sheet 1 of 2) ...	4-3
4-3. Positions of Least Backward Stability (Sheet 2 of 2) ...	4-4
4-4. ASOV Reset (Closed to Open Position)	4-7
4-5. Grade and Sideslopes	4-9
4-6. Lifting Chart	4-18
4-7. Tow Bar	4-20
4-8. Releveling Valve	4-23
4-9. Decal Installation - Sheet 1 of 5.....	4-24
4-10. Decal Installation - Sheet 2 of 5.....	4-25
4-11. Decal Installation - Sheet 3 of 5.....	4-26
4-12. Decal Installation - Sheet 4 of 5.....	4-27

FIGURE NUMBER - TITLE	PAGE
4-13. Decal Installation - Sheet 5 of 5	4-28
6-1. Bolt-On External Fall Arrest Cable Tension	6-16
6-2. Bolt-On External Fall Arrest System	6-18
7-1. Engine Operating Temperature Specifications - Deutz - .. Sheet 1 of 2.....	7-9
7-2. Engine Operating Temperature Specifications - Deutz - .. Sheet 2 of 2.....	7-10
7-3. Engine Operating Temperature Specifications - GM - Sheet 1 of 2.....	7-11
7-4. Engine Operating Temperature Specifications - GM - Sheet 2 of 2.....	7-12
7-5. Maintenance and Lubrication Diagram	7-13
7-6. Deutz 2011 Engine Dipstick	7-19
7-7. Filter Lock Assembly	7-27

LIST OF FIGURES

FIGURE NUMBER - TITLE

PAGE

FIGURE NUMBER - TITLE

PAGE

This Page Left Blank Intentionally

TABLE NUMBER - TITLE	PAGE	TABLE NUMBER - TITLE	PAGE
1-1	Minimum Approach Distances (M.A.D.)	1-6	
1-2	Beaufort Scale (For Reference Only).....	1-9	
2-1	Inspection and Maintenance Table	2-3	
4-1	Decal Legend - 800A	4-29	
4-2	Decal Legend - 800AJ	4-33	
6-1	Available Accessories	6-1	
6-2	Options/Accessories Relationship Table.....	6-2	
7-1	Operating Specifications	7-1	
7-2	Tire Specifications.....	7-2	
7-3	Capacities	7-3	
7-4	Deutz D2011L04 Specifications.....	7-3	
7-5	Deutz TD 2.9 Specifications.....	7-4	
7-6	GM 3.0L.....	7-4	
7-7	Hydraulic Oil	7-5	
7-8	Mobilfluid 424 Specs	7-5	
7-9	Mobil DTE 10 Excel 32 Specs.....	7-6	
7-10	Mobil EAL 224H Specs.....	7-6	
7-11	UCon Hydrolube HP-5046.....	7-7	
7-12	Exxon Univis HVI 26 Specs.....	7-7	
7-13	Critical Stability Weights.....	7-8	
7-14	Lubrication Specifications.....	7-14	
7-15	Wheel Torque Chart.....	7-26	
8-1	Inspection and Repair Log.....	8-1	

LIST OF TABLES

TABLE NUMBER - TITLE

PAGE

TABLE NUMBER - TITLE

PAGE

This Page Left Blank Intentionally

SECTION 1. SAFETY PRECAUTIONS

1.1 GENERAL

This section outlines the necessary precautions for proper and safe machine usage and maintenance. It is mandatory that a daily routine is established based on the content of this manual to promote proper machine usage. A maintenance program, using the information provided in this manual and the Service and Maintenance Manual, must also be established by a qualified person and must be followed to ensure that the machine is safe to operate.

The owner/user/operator/lessor/lessee of the machine must not accept operating responsibility until this manual has been read, training is accomplished, and operation of the machine has been completed under the supervision of an experienced and qualified operator.

This section contains the responsibilities of the owner, user, operator, lessor, and lessee concerning safety, training, inspection, maintenance, application, and operation. If there are any questions with regard to safety, training, inspection, maintenance, application, and operation, please contact JLG Industries, Inc. ("JLG").

WARNING

FAILURE TO COMPLY WITH THE SAFETY PRECAUTIONS LISTED IN THIS MANUAL COULD RESULT IN MACHINE DAMAGE, PROPERTY DAMAGE, PERSONAL INJURY OR DEATH.

1.2 PRE-OPERATION

Operator Training and Knowledge

- The Operation and Safety Manual must be read and understood in its entirety before operating the machine. For clarification, questions, or additional information regarding any portions of this manual, contact JLG Industries, Inc.

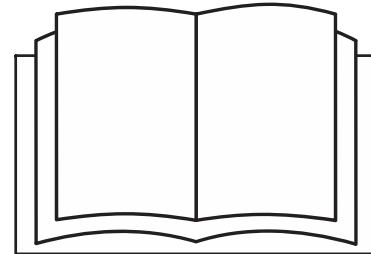

SECTION 1 - SAFETY PRECAUTIONS

- An operator must not accept operating responsibilities until adequate training has been given by competent and authorized persons.
- Allow only those authorized and qualified personnel to operate the machine who have demonstrated that they understand the safe and proper operation and maintenance of the unit.
- Read, understand, and obey all DANGERS, WARNINGS, CAUTIONS, and operating instructions on the machine and in this manual.
- Ensure that the machine is to be used in a manner which is within the scope of its intended application as determined by JLG.
- All operating personnel must be familiar with the emergency controls and emergency operation of the machine as specified in this manual.
- Read, understand, and obey all applicable employer, local, and governmental regulations as they pertain to your utilization and application of the machine.

Workplace Inspection

- Precautions to avoid all hazards in the work area must be taken by the user before and during operation of the machine.
- Do not operate or raise the platform from a position on trucks, trailers, railway cars, floating vessels, scaffolds or other equipment unless the application is approved in writing by JLG.
- Before operation, check work area for overhead hazards such as electric lines, bridge cranes, and other potential overhead obstructions.
- Check operating surfaces for holes, bumps, drop-offs, obstructions, debris, concealed holes, and other potential hazards.
- Check the work area for hazardous locations. Do not operate the machine in hazardous environments unless approved for that purpose by JLG.
- Ensure that the ground conditions are adequate to support the maximum tire load indicated on the tire load decals located on the chassis adjacent to each wheel. Do not travel on unsupported surfaces.

Machine Inspection

- Do not operate this machine until the inspections and functional checks as specified in Section 2 of this manual have been performed.
- Do not operate this machine until it has been serviced and maintained according to the maintenance and inspection requirements as specified in the machine's Service and Maintenance Manual.
- Ensure all safety devices are operating properly. Modification of these devices is a safety violation.

WARNING

MODIFICATION OR ALTERATION OF AN AERIAL WORK PLATFORM SHALL BE MADE ONLY WITH PRIOR WRITTEN PERMISSION FROM THE MANUFACTURER.

- Do not operate any machine on which the safety or instruction placards or decals are missing or illegible.
- Check the machine for modifications to original components. Ensure that any modifications have been approved by JLG.
- Avoid accumulation of debris on platform floor. Keep mud, oil, grease, and other slippery substances from footwear and platform floor.

1.3 OPERATION

General

- Machine operation requires your full attention. Bring the machine to a full stop before using any device, i.e. cell phones, two-way radios, etc. that will distract your attention from safely operating the machine.
- Do not use the machine for any purpose other than positioning personnel, their tools, and equipment.
- Before operation, the user must be familiar with the machine capabilities and operating characteristics of all functions.
- Never operate a malfunctioning machine. If a malfunction occurs, shut down the machine. Remove the unit from service and notify the proper authorities.
- Do not remove, modify, or disable any safety devices.
- Never slam a control switch or lever through neutral to an opposite direction. Always return switch to neutral and stop before moving the switch to the next function. Operate controls with slow and even pressure.
- Do not allow personnel to tamper with or operate the machine from the ground with personnel in the platform, except in an emergency.

SECTION 1 - SAFETY PRECAUTIONS

- Do not carry materials directly on platform railing unless approved by JLG.
- When two or more persons are in the platform, the operator shall be responsible for all machine operations.
- Always ensure that power tools are properly stowed and never left hanging by their cord from the platform work area.
- When driving, always position boom over rear axle in line with the direction of travel. Remember, if boom is over the front axle, steer and drive functions will be reversed.
- Do not assist a stuck or disabled machine by pushing or pulling except by pulling at the chassis tie-down lugs.
- Fully lower platform and shut off all power before leaving machine.
- Remove all rings, watches, and jewelry when operating machine. Do not wear loose fitting clothing or long hair unrestrained which may become caught or entangled in equipment.
- Persons under the influence of drugs or alcohol or who are subject to seizures, dizziness or loss of physical control must not operate this machine.
- Hydraulic cylinders are subject to thermal expansion and contraction. This may result in changes to the boom and/or platform position while the machine is stationary. Factors affecting thermal movement can include the length of time

the machine will remain stationary, hydraulic oil temperature, ambient air temperature, and boom and platform position.

Trip and Fall Hazards

- During operation, occupants in the platform must wear a full body harness with a lanyard attached to an authorized lanyard anchorage point. Attach only one (1) lanyard per lanyard anchorage point.

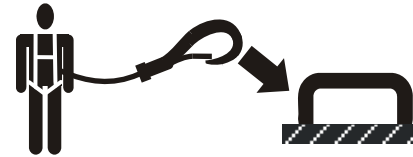

- Enter and exit only through gate area. Use extreme caution when entering or leaving platform. Ensure that the platform assembly is fully lowered. Face the machine when entering or leaving the platform. Always maintain “three point contact” with the machine, using two hands and one foot or two feet and one hand at all times during entry and exit.

- Before operating the machine, make sure all gates are closed and fastened in their proper position.

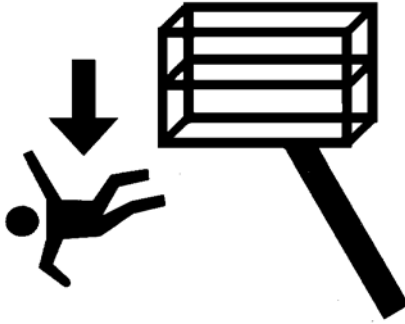

- Keep both feet firmly positioned on the platform floor at all times. Never position ladders, boxes, steps, planks, or similar items on unit to provide additional reach for any purpose.
- Keep oil, mud, and slippery substances cleaned from footwear and the platform floor.

Electrocution Hazards

- This machine is not insulated and does not provide protection from contact or proximity to electrical current.

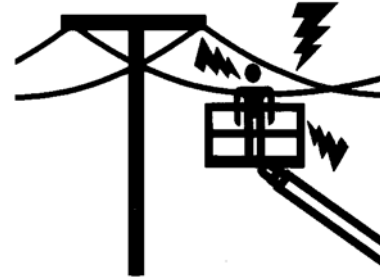

SECTION 1 - SAFETY PRECAUTIONS

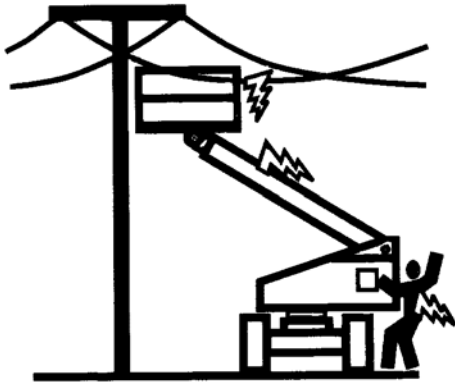

- Maintain distance from electrical lines, apparatus, or any energized (exposed or insulated) parts according to the Minimum Approach Distance (MAD) as shown in Table 1-1.
- Allow for machine movement and electrical line swaying.

Table 1-1. Minimum Approach Distances (M.A.D.)

Voltage Range (Phase to Phase)	MINIMUM APPROACH DISTANCE in Feet (Meters)
0 to 50 KV	10 (3)
Over 50KV to 200 KV	15 (5)
Over 200 KV to 350 KV	20 (6)
Over 350 KV to 500 KV	25 (8)
Over 500 KV to 750 KV	35 (11)
Over 750 KV to 1000 KV	45 (14)

NOTE: *This requirement shall apply except where employer, local or governmental regulations are more stringent.*

- Maintain a clearance of at least 10 ft. (3m) between any part of the machine and its occupants, their tools, and their equipment from any electrical line or apparatus carrying up to 50,000 volts. One foot additional clearance is required for every additional 30,000 volts or less.

- The minimum approach distance may be reduced if insulating barriers are installed to prevent contact, and the barriers are rated for the voltage of the line being guarded. These barriers shall not be part of (or attached to) the machine. The minimum approach distance shall be reduced to a distance within the designed working dimensions of the insulating barrier. This determination shall be made by a qualified person in accordance with the employer, local, or governmental requirements for work practices near energized equipment.

⚠ DANGER

DO NOT MANEUVER MACHINE OR PERSONNEL INSIDE PROHIBITED ZONE (MAD). ASSUME ALL ELECTRICAL PARTS AND WIRING ARE ENERGIZED UNLESS KNOWN OTHERWISE.

Tipping Hazards

- The user must be familiar with the surface before driving. Do not exceed the allowable sideslope and grade while driving.

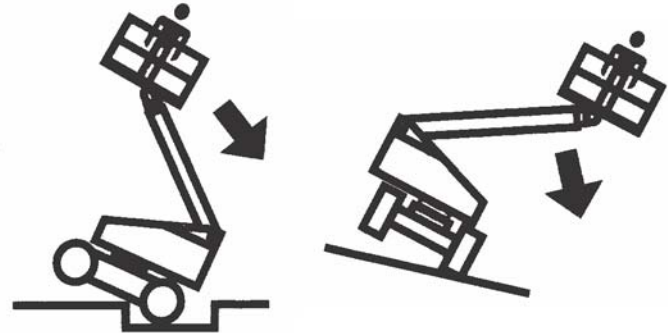

- Do not elevate platform or drive with platform elevated while on or near a sloping, uneven, or soft surface. Ensure machine is positioned on a firm, level and smooth surface before elevating platform or driving with the platform in the elevated position.
- Before driving on floors, bridges, trucks, and other surfaces, check allowable capacity of the surfaces.

SECTION 1 - SAFETY PRECAUTIONS

- Never exceed the maximum work load as specified on the platform. Keep all loads within the confines of the platform, unless authorized by JLG.
- Keep the chassis of the machine a minimum of 2 ft. (0.6m) from holes, bumps, drop-offs, obstructions, debris, concealed holes, and other potential hazards at the ground level.
- Do not push or pull any object with the boom.
- Never attempt to use the machine as a crane. Do not tie-off machine to any adjacent structure. Never attach wire, cable, or any similar items to platform.
- If boom assembly or platform is in a position that one or more wheels are off the ground, all persons must be removed before attempting to stabilize the machine. Use cranes, forklift trucks, or other appropriate equipment to stabilize machine.
- Do not operate the machine when wind conditions, including gusts, may exceed 28 mph (12.5 m/s). Factors affecting wind speed are; platform elevation, surrounding structures, local weather events, and approaching storms. Refer to Table 1-2, Beaufort scale (For Reference Only) or use other means to monitor wind conditions.
- Wind speed can be significantly greater at height than at ground level.
- Wind speed can change rapidly. Always consider approaching weather events, the time required to lower the platform, and methods to monitor current and potential wind conditions.
- Do not increase surface area of the platform or the load. Increased areas exposed to wind will decrease stability.
- Do not increase the platform size with unauthorized modifications or attachments.

NOTICE

DO NOT OPERATE THE MACHINE WHEN WIND CONDITIONS EXCEED 28 MPH (12.5 M/S).

Table 1-2. Beaufort Scale (For Reference Only)

Beaufort Number	Wind Speed		Description	Land Conditions
	mph	m/s		
0	0	0-0.2	Calm	Calm. Smoke rises vertically
1	1-3	0.3-1.5	Light air	Wind motion visible in smoke
2	4-7	1.6-3.3	Light breeze	Wind felt on exposed skin. Leaves rustle
3	8-12	3.4-5.4	Gentle breeze	Leaves and smaller twigs in constant motion
4	13-18	5.5-7.9	Moderate breeze	Dust and loose paper raised. Small branches begin to move.
5	19-24	8.0-10.7	Fresh breeze	Smaller trees sway.
6	25-31	10.8-13.8	Strong breeze	Large branches in motion. Flags waving near horizontal. Umbrella use becomes difficult.
7	32-38	13.9-17.1	Near Gale/Moderate Gale	Whole trees in motion. Effort needed to walk against the wind.
8	39-46	17.2-20.7	Fresh Gale	Twigs broken from trees. Cars veer on road.
9	47-54	20.8-24.4	Strong Gale	Light structure damage.

Crushing and Collision Hazards

- Approved head gear must be worn by all operating and ground personnel.
- Check work area for clearances overhead, on sides, and bottom of platform when lifting or lowering platform, and driving.

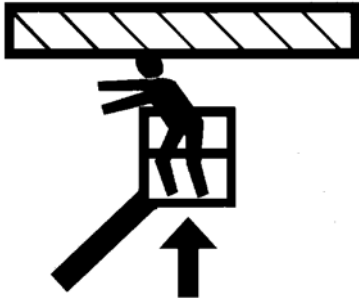

- During operation, keep all body parts inside platform railing.
- Use the boom functions, not the drive function, to position the platform close to obstacles.
- Always post a lookout when driving in areas where vision is obstructed.

- Keep non-operating personnel at least 6 ft. (1.8m) away from machine during all driving and swing operations.
- Under all travel conditions, the operator must limit travel speed according to conditions of ground surface, congestion, visibility, slope, location of personnel, and other factors which may cause collision or injury to personnel.
- Be aware of stopping distances in all drive speeds. When driving in high speed, switch to low speed before stopping. Travel grades in low speed only.
- Do not use high speed drive in restricted or close quarters or when driving in reverse.
- Exercise extreme caution at all times to prevent obstacles from striking or interfering with operating controls and persons in the platform.
- Be sure that operators of other overhead and floor level machines are aware of the aerial work platform's presence. Disconnect power to overhead cranes.
- Warn personnel not to work, stand, or walk under a raised boom or platform. Position barricades on floor if necessary.

1.4 TOWING, LIFTING, AND HAULING

- Never allow personnel in platform while towing, lifting, or hauling.
- This machine should not be towed, except in the event of emergency, malfunction, power failure, or loading/unloading. Refer to the Emergency Procedures section of this manual for emergency towing procedures.
- Ensure boom is in the stowed position and, if equipped, the turntable locked prior to towing, lifting or hauling. The platform must be completely empty of tools.
- When lifting machine, lift only at designated areas of the machine. Lift the unit with equipment of adequate capacity.
- Refer to the Machine Operation section of this manual for lifting information.

1.5 MAINTENANCE

This sub-section contains general safety precautions which must be observed during maintenance of this machine. Additional precautions to be observed during machine maintenance are inserted at the appropriate points in this manual and in the Service and Maintenance Manual. It is of utmost importance that maintenance personnel pay strict attention to these precautions to avoid possible injury to personnel or damage to the machine or property. A maintenance program must be established by a qualified person and must be followed to ensure that the machine is safe.

Maintenance Hazards

- Shut off power to all controls and ensure that all moving parts are secured from inadvertent motion prior to performing any adjustments or repairs.
- Never work under an elevated platform until it has been fully lowered to the full down position, if possible, or otherwise supported and restrained from movement with appropriate safety props, blocking, or overhead supports.
- DO NOT attempt to repair or tighten any hydraulic hoses or fittings while the machine is powered on or when the hydraulic system is under pressure.
- Always relieve hydraulic pressure from all hydraulic circuits before loosening or removing hydraulic components.

SECTION 1 - SAFETY PRECAUTIONS

- DO NOT use your hand to check for leaks. Use a piece of cardboard or paper to search for leaks. Wear gloves to help protect hands from spraying fluid.



- Ensure replacement parts or components are identical or equivalent to original parts or components.
- Never attempt to move heavy parts without the aid of a mechanical device. Do not allow heavy objects to rest in an unstable position. Ensure adequate support is provided when raising components of the machine.

- Do not use machine as a ground for welding.
- When performing welding or metal cutting operations, precautions must be taken to protect the chassis from direct exposure to weld and metal cutting spatter.
- Do not refuel the machine with the engine running.
- Use only approved non-flammable cleaning solvents.
- Do not replace items critical to stability, such as batteries or solid tires, with items of different weight or specification. Do not modify unit in any way to affect stability.
- Refer to the Service and Maintenance Manual for the weights of critical stability items.

⚠ WARNING

MODIFICATION OR ALTERATION OF AN AERIAL WORK PLATFORM SHALL BE MADE ONLY WITH PRIOR WRITTEN PERMISSION FROM THE MANUFACTURER.

Battery Hazards

- Always disconnect batteries when servicing electrical components or when performing welding on the machine.
- Do not allow smoking, open flame, or sparks near battery during charging or servicing.
- Do not contact tools or other metal objects across the battery terminals.
- Always wear hand, eye, and face protection when servicing batteries. Ensure that battery acid does not come in contact with skin or clothing.

CAUTION

BATTERY FLUID IS HIGHLY CORROSIVE. AVOID CONTACT WITH SKIN AND CLOTHING AT ALL TIMES. IMMEDIATELY RINSE ANY CONTACTED AREA WITH CLEAN WATER AND SEEK MEDICAL ATTENTION.

- Charge batteries only in a well ventilated area.
- Avoid overfilling the battery fluid level. Add distilled water to batteries only after the batteries are fully charged.

SECTION 1 - SAFETY PRECAUTIONS

 **NOTES:**

SECTION 2. USER RESPONSIBILITIES, MACHINE PREPARATION, AND INSPECTION

2.1 PERSONNEL TRAINING

The aerial platform is a personnel handling device; so it is necessary that it be operated and maintained only by trained personnel.

Persons under the influence of drugs or alcohol or who are subject to seizures, dizziness or loss of physical control must not operate this machine.

Operator Training

Operator training must cover:

1. Use and limitations of the controls in the platform and at the ground, emergency controls and safety systems.
2. Control labels, instructions, and warnings on the machine.
3. Rules of the employer and government regulations.
4. Use of approved fall protection device.
5. Enough knowledge of the mechanical operation of the machine to recognize a malfunction or potential malfunction.

6. The safest means to operate the machine where overhead obstructions, other moving equipment, and obstacles, depressions, holes, or drop-offs exist.
7. Means to avoid the hazards of unprotected electrical conductors.
8. Specific job requirements or machine application.

Training Supervision

Training must be done under the supervision of a qualified person in an open area free of obstructions until the trainee has developed the ability to safely control and operate the machine.

Operator Responsibility

The operator must be instructed that he/she has the responsibility and authority to shut down the machine in case of a malfunction or other unsafe condition of either the machine or the job site.

2.2 PREPARATION, INSPECTION, AND MAINTENANCE

The following table covers the periodic machine inspections and maintenance required by JLG Industries, Inc. Consult local regulations for further requirements for aerial work platforms. The frequency of inspections and maintenance must be increased as necessary when the machine is used in a harsh or hostile environment, if the machine is used with increased frequency, or if the machine is used in a severe manner.

NOTICE

JLG INDUSTRIES, INC. RECOGNIZES A FACTORY TRAINED SERVICE TECHNICIAN AS A PERSON WHO HAS SUCCESSFULLY COMPLETED THE JLG SERVICE TRAINING SCHOOL FOR THE SPECIFIC JLG PRODUCT MODEL.

SECTION 2 - USER RESPONSIBILITIES, MACHINE PREPARATION, AND INSPECTION

Table 2-1. Inspection and Maintenance Table

Type	Frequency	Primary Responsibility	Service Qualification	Reference
Pre-Start Inspection	Before using each day; or whenever there's an Operator change.	User or Operator	User or Operator	Operation and Safety Manual
Pre-Delivery Inspection (See Note)	Before each sale, lease, or rental delivery.	Owner, Dealer, or User	Qualified JLG Mechanic	Service and Maintenance Manual and applicable JLG inspection form
Frequent Inspection (See Note)	In service for 3 months or 150 hours, whichever comes first; or Out of service for a period of more than 3 months; or Purchased used.	Owner, Dealer, or User	Qualified JLG Mechanic	Service and Maintenance Manual and applicable JLG inspection form
Annual Machine Inspection (See Note)	Annually, no later than 13 months from the date of prior inspection.	Owner, Dealer, or User	Factory Trained Service Technician (Recommended)	Service and Maintenance Manual and applicable JLG inspection form
Preventative Maintenance	At intervals as specified in the Service and Maintenance Manual.	Owner, Dealer, or User	Qualified JLG Mechanic	Service and Maintenance Manual
NOTE: Inspection forms are available from JLG. Use the Service and Maintenance Manual to perform inspections.				

SECTION 2 - USER RESPONSIBILITIES, MACHINE PREPARATION, AND INSPECTION

Pre-Start Inspection

The Pre-Start Inspection should include each of the following:

1. **Cleanliness** – Check all surfaces for leakage (oil, fuel, or battery fluid) or foreign objects. Report any leakage to the proper maintenance personnel.
2. **Structure** - Inspect the machine structure for dents, damage, weld or parent metal cracks or other discrepancies.

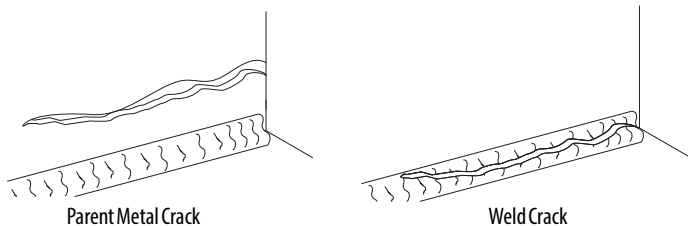

3. **Decals and Placards** – Check all for cleanliness and legibility. Make sure none of the decals and placards are missing. Make sure all illegible decals and placards are cleaned or replaced.
4. **Operators and Safety Manuals** – Make sure a copy of the Operator and Safety Manual, EMI Safety Manual (Domestic only), and ANSI Manual of Responsibilities (Domestic only) is enclosed in the weather resistant storage container.

5. **“Walk-Around” Inspection** – Refer to Figure 2-2. and Figure 2-3.
6. **Battery** – Charge as required.
7. **Fuel** (Combustion Engine Powered Machines) – Add the proper fuel as necessary.
8. **Engine Oil Supply** - Ensure the engine oil level is at the Full mark on the dipstick and the filler cap is secure.
9. **Hydraulic Oil** – Check the hydraulic oil level. Ensure hydraulic oil is added as required.
10. **Accessories/Attachments** - Refer to the Accessories section in this manual or the accessory installed upon the machine for specific inspection, operation, and maintenance instructions.
11. **Function Check** - Once the "Walk-Around" Inspection is complete, perform a functional check of all systems in accordance with Section 2.3 in an area free of overhead and ground level obstructions. Refer to Sections 3 and 4 for more specific machine operating instructions.

WARNING

IF THE MACHINE DOES NOT OPERATE PROPERLY, TURN OFF THE MACHINE IMMEDIATELY! REPORT THE PROBLEM TO THE PROPER MAINTENANCE PERSONNEL. DO NOT OPERATE THE MACHINE UNTIL IT IS DECLARED SAFE FOR OPERATION.

SECTION 2 - USER RESPONSIBILITIES, MACHINE PREPARATION, AND INSPECTION

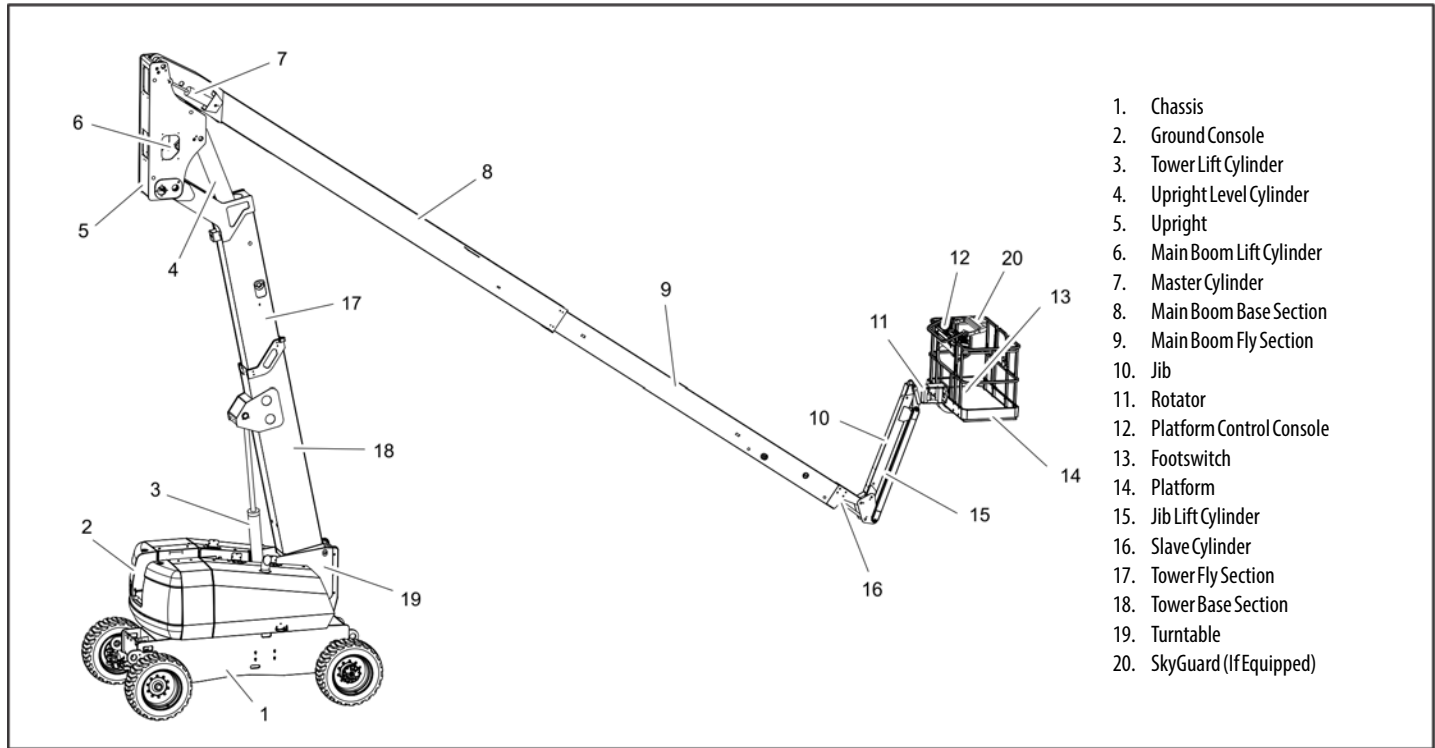
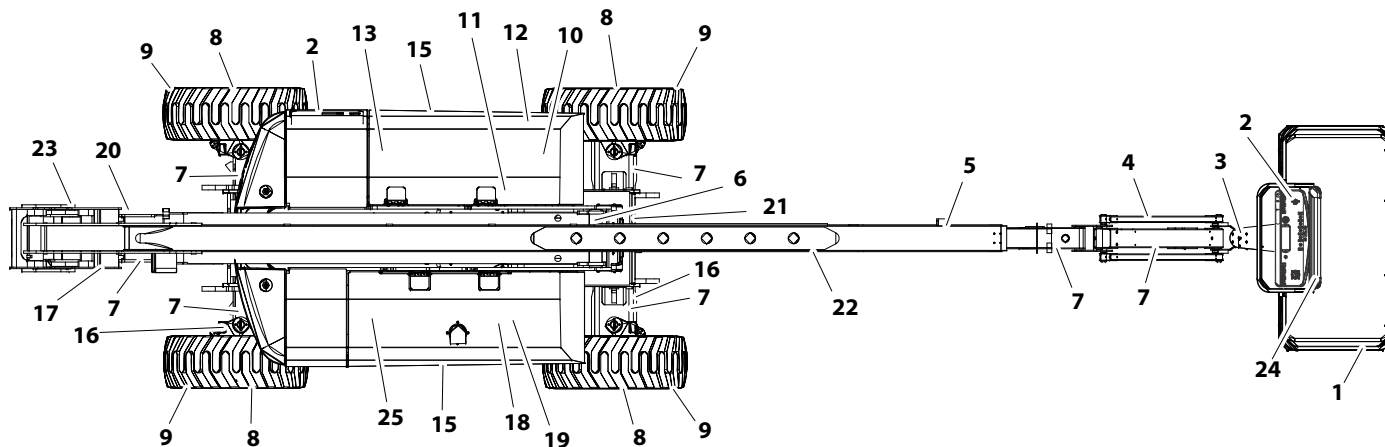

Figure 2-1. Basic Nomenclature

SECTION 2 - USER RESPONSIBILITIES, MACHINE PREPARATION, AND INSPECTION



OAC00390

Figure 2-2. Daily Walk-Around Inspection (Sheet 1 of 3)

General

Begin the "Walk-Around Inspection" at Item 1, as noted on the diagram. Continue checking each item in sequence for the conditions listed in the following checklist.

WARNING

TO AVOID POSSIBLE INJURY BE SURE MACHINE POWER IS OFF.

INSPECTION NOTE: *On all components, make sure there are no loose or missing parts, that they are securely fastened, and no visible damage, leaks or excessive wear exists in addition to any other criteria mentioned.*

1. Platform Assembly and Gate - Footswitch works properly, not modified, disabled or blocked. Latch and hinges in working condition.
2. Platform & Ground Control Consoles - Switches and levers return to neutral, decals/placards secure and legible, control markings legible.
3. Rotator - See Inspection Note.
4. Jib - See Inspection Note.
5. Dual Capacity Limit Switch (ANSI, Australia, if equipped); Transport Position Limit Switch (CE) - Properly secured, no damage to the switch, arm free to move, and free from dirt and grease.
6. Power Track - See Inspection Note.
7. All Hydraulic Cylinders - See Inspection Note.
8. Drive Motor, Brake, and Hub - See Inspection Note.
9. Wheel/Tire Assemblies - Properly secured, no missing lug nuts. Inspect for worn tread, cuts, tears or other discrepancies. Inspect wheels for damage and corrosion.
10. Main Control Valve - See Inspection Note.
11. Turntable Bearing - Evidence of proper lubrication. No evidence of loose bolts or looseness between bearing and structure.
12. Manual Descent - See Inspection Note. (if equipped)

Figure 2-3. Daily Walk-Around Inspection (Sheet 2 of 3)

SECTION 2 - USER RESPONSIBILITIES, MACHINE PREPARATION, AND INSPECTION

- 13.** Fuel Tank - See Inspection Note.
- 14.** Swing Drive Motor and Brake - See Inspection Note.
- 15.** Door and Latches - Hood door and latches in working condition, properly secured, no loose or missing parts.
- 16.** Tie Rod and Steering Linkage - See Inspection Note.
- 17.** Dual Capacity and Horizontal Cutout Limit Switches if equipped - Properly secured, no damage to the switches, arm free to move, and free from dirt and grease.
- 18.** Battery - Proper electrolyte levels; cables tight, no visible damage or corrosion.
- 19.** Hydraulic Pumps - See Inspection Note.
- 20.** Tower Boom - No visible damage; wear pads secure. All cylinders - rod end pins and barrel-end pins properly secured.
- 21.** Frame - See Inspection Note.
- 22.** Main Boom Sections - No visible damage; wear pads secure. All cylinders - rod end shafts and barrel-end shafts properly secured.
- 23.** Upright - In vertical position, relative to the chassis. Refer to Figure 2-7. and Figure 2-8. If out of alignment, do not use machine until the upright has been synchronized in accordance with Section 4.16.
- 24.** SkyGuard - See Inspection Note.
- 25.** Air Shutoff Valve (ASOV) (If Equipped) - See Inspection Note.

Figure 2-4. Daily Walk-Around Inspection (Sheet 3 of 3)

2.3 FUNCTION CHECK

Perform a function check of all systems, once the walk-around inspection is complete, in an area free of overhead and ground level obstructions.

⚠ WARNING

A MACHINE MALFUNCTION COULD CAUSE DEATH OR SERIOUS INJURY. IF ANY MALFUNCTIONS OCCUR DURING THE FUNCTION TEST, DISCONTINUE OPERATION AND CONTACT A QUALIFIED SERVICE TECHNICIAN TO CORRECT THE MALFUNCTION BEFORE OPERATING THE MACHINE.

From the Ground Control Station with No Load in the Platform:

1. Check that all guards protecting the function switches or locks are in place. Ensure that all function controls and switches return to the "off" or neutral position when released.

⚠ WARNING

DO NOT OPERATE IF GUARDS OR LOCKS ARE MISSING OR THE SWITCHES DO NOT RETURN TO THE "OFF" OR NEUTRAL POSITION

2. Test the tower boom assembly sequencing as follows:

- a. Place machine on level ground with the tower boom assembly in the stowed position. Identify the tower boom vertical limit switch adjacent to the tower lift cylinder at the bottom end (rear) of the tower base boom. Open the left side hood and perform a visual check that the plunger on the tower boom vertical limit switch is fully extended. The plunger is shown fully extended in Figure 2-5.

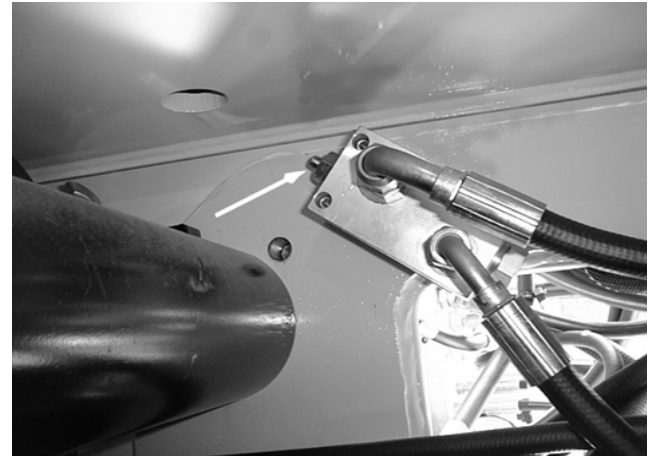

Figure 2-5. Tower Boom Vertical Limit Switch

SECTION 2 - USER RESPONSIBILITIES, MACHINE PREPARATION, AND INSPECTION

⚠ WARNING

DISCONTINUE OPERATION IF PLUNGER IS NOT FULLY EXTENDED

- b. Attempt to extend the tower fly boom. The tower fly boom should not extend and the red boom malfunction light in the ground control panel should illuminate when pressing the tower telescope switch.

⚠ WARNING

DISCONTINUE OPERATION IF THE TOWER FLY BOOM EXTENDS OR THE BOOM MALFUNCTION LIGHT DOES NOT ILLUMINATE.

- c. Raise the tower base boom to approximately 40 degrees, then lower the tower boom back to the below horizontal position. While raising and lowering the tower boom assembly, observe the position of the upright. Ensure that the upright remains vertical relative to the chassis. Refer to Figure 2-7. and Figure 2-8.

⚠ WARNING

DISCONTINUE OPERATION IF THE UPRIGHT IS OUT OF ALIGNMENT OR THE BOOM MALFUNCTION LIGHT IS FLASHING OR ON STEADY.

- d. Raise the tower base boom to full height. Extend the tower fly boom a few feet. Check that the plunger on

the tower boom horizontal limit switch at the end of the tower base boom section is fully extended. The plunger is shown fully extended in Figure 2-6.



Figure 2-6. Tower Boom Horizontal Limit Switch

⚠ WARNING

DISCONTINUE OPERATION IF PLUNGER IS NOT FULLY EXTENDED

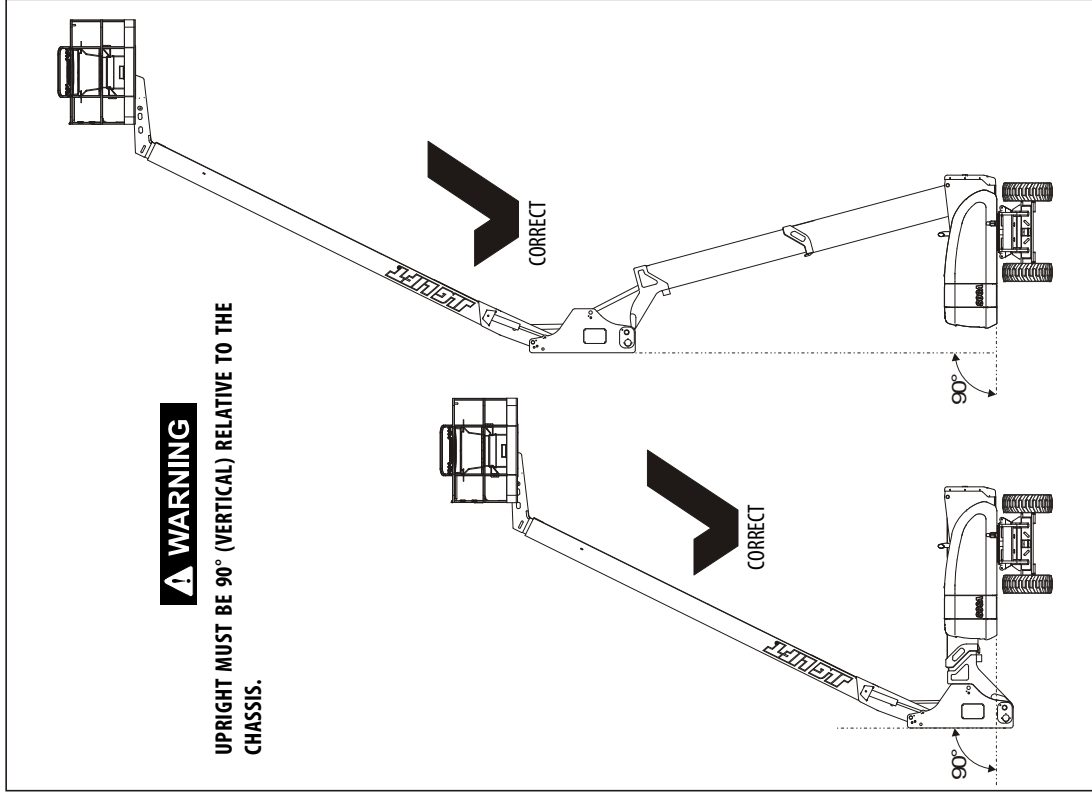

Figure 2-7. Boom Upright Positioning - Correct

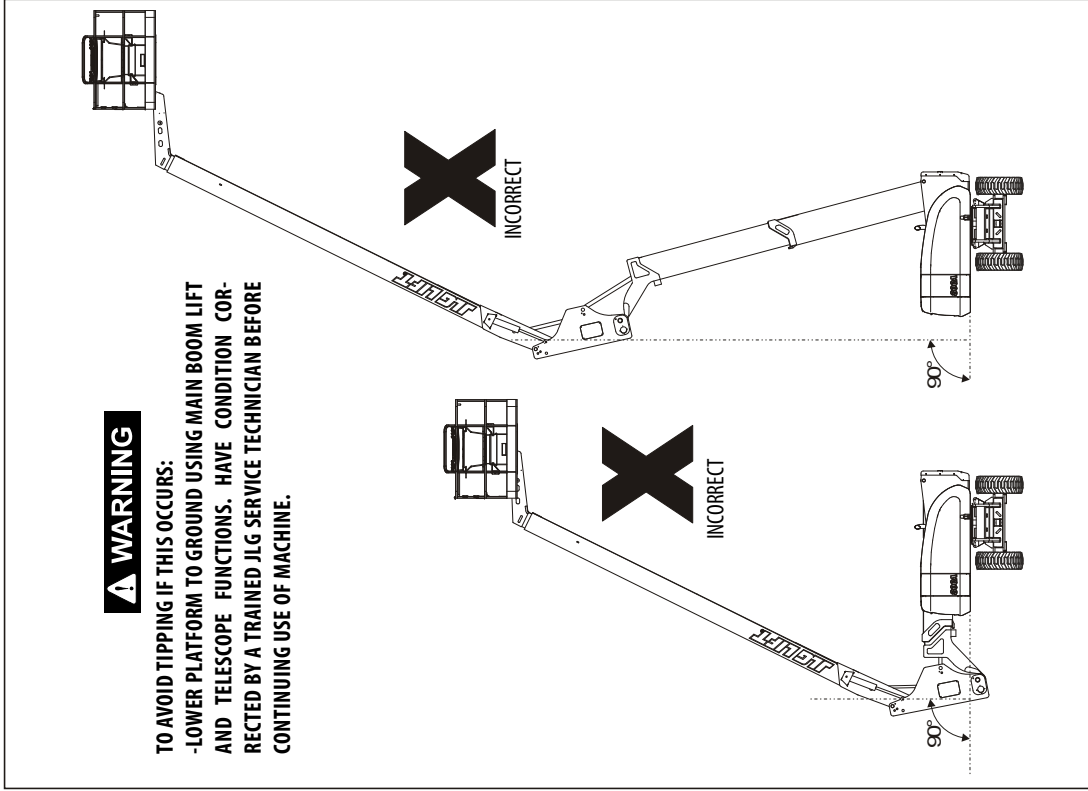

Figure 2-8. Boom Upright Positioning - Incorrect

SECTION 2 - USER RESPONSIBILITIES, MACHINE PREPARATION, AND INSPECTION

- e. Attempt to lower the tower base boom while the tower fly boom is extended. The tower base boom should not lower and the red boom malfunction light should illuminate when pressing the tower down switch.

WARNING

DISCONTINUE OPERATION IF THE TOWER BASE BOOM LOWERS OR THE BOOM MALFUNCTION LIGHT DOES NOT ILLUMINATE.

- f. Check that all machine functions are disabled when the Emergency Stop Button is pushed in.
- g. Check for proper operation of the auxiliary power and manual descent system (if equipped). Operate each function control to ensure proper operation.

From the Platform Control Station:

- 1. Check that the control console is secure and all guards protecting the function switches or locks are in place. Ensure that all function controls and switches return to the "off" or neutral position when released.

WARNING

DO NOT OPERATE MACHINE IF GUARDS OR LOCKS ARE MISSING OR THE SWITCHES DO NOT RETURN TO THE "OFF" OR NEUTRAL POSITION

- 2. Check the footswitch adjustment and operation as follows:
 - a. With engine power shut down, attempt to start engine. Engine should not attempt to start when footswitch is activated.
 - b. Start engine. Activate hydraulic system by depressing footswitch. Activate a boom function. Continue to activate the function and remove foot from footswitch. The motion should stop.

WARNING

DISCONTINUE OPERATION IF THE FOOTSWITCH DOES NOT OPERATE PROPERLY.

- c. Check adjustment of footswitch. Footswitch must be adjusted so that functions will operate when pedal is approximately at its center of travel. If the footswitch operates within last 1/4" of travel, top or bottom, it should be adjusted.

NOTE: *Footswitch has a 7 second delay timer. If a function is not activated within 7 seconds after depressing the footswitch, reset the footswitch.*

- 3. Ensure that all machine functions are disabled when the Emergency Stop Button is activated.

SECTION 2 - USER RESPONSIBILITIES, MACHINE PREPARATION, AND INSPECTION

4. Check auxiliary power for proper operation. Operate each function control switch to ensure proper operation of the auxiliary power system.

NOTE: *Step 5 is only applicable for 800A ANSI market machines.*

5. If equipped with a dual capacity system, check the limit switch as follows:
 - a. On a level surface with less than 500 lb (227 kg) in the platform, raise tower base boom to maximum angle keeping main boom horizontal.
 - b. Extend the main fly boom until the capacity indicator lights change from 1000 lb. (454 kg) to 500 lb. (227 kg).
 - c. With main boom in this position, raise the main base boom until the capacity indicator lights change back to the 1000 lb. (454 kg) indicator.

WARNING

DISCONTINUE OPERATION IF THE CAPACITY INDICATOR SYSTEM DOES NOT OPERATE PROPERLY.

6. Drive forward and reverse; check for proper operation.
7. Steer left and right; check for proper operation.
8. Check the high-drive cutout for the tower boom assembly as follows:
 - a. Place machine on level surface with booms retracted and lowered.
 - b. From the platform control, position Drive Speed/Torque Select switch to Fast (Forward Position).
 - c. Using extreme caution, partially position the DRIVE control to Forward just enough to cause the machine to move.
 - d. Raise the Tower Boom until the drive speed shifts from high speed to slow or creep speed. The bottom of the upright should NOT be above the hood level of the machine.

SECTION 2 - USER RESPONSIBILITIES, MACHINE PREPARATION, AND INSPECTION

9. Check the high-drive cutout for the main boom assembly as follows:

- a. Place machine on level surface with booms retracted and lowered.
- b. From the platform control, position Drive Speed/Torque Select switch to Fast (Forward Position).
- c. Raise the main boom above horizontal.
- d. Using extreme caution, partially position the DRIVE control to FORWARD just enough to cause the machine to move. The drive speed should be in slow or creep mode.

10. Swing turntable to Left and Right a minimum of 45 degrees. Check for smooth motion.

NOTE: *Ensure the turntable lock is disengaged. To disengage lock, pull snap pin from lock pin, lift lock pin up to unlock turntable. Return snap pin to lock pin to hold lock pin in the disengaged position. Reverse procedure to engage turntable lock.*

11. Check the Tilt Alarm and Warning System as follows:



IF THE TILT ALARM AND WARNING SYSTEM DOES NOT OPERATE PROPERLY, DISCONTINUE OPERATION. CONTACT A QUALIFIED SERVICE TECHNICIAN TO CORRECT THE MALFUNCTION BEFORE OPERATING THE MACHINE.

With the platform in the transport position (tower base boom lowered, main fly boom retracted, and main base boom below horizontal) drive up a suitable ramp of at least 5° slope. The tilt indicator light on the platform control console should illuminate.

12. Check that the platform automatically levels properly during raising and lowering of the boom.

13. Check that the platform level override operates properly.

SECTION 2 - USER RESPONSIBILITIES, MACHINE PREPARATION, AND INSPECTION

14. Check platform rotator for smooth operation and assure platform will rotate 90 degrees in both directions from centerline of boom.
15. If equipped with 4-wheel steer, check rear steer left and right for proper operation.
16. If equipped, raise and lower the articulating jib boom. Check for smooth operation.
17. If equipped with Auxiliary Power, operate each function control switch to assure that they function in both directions using auxiliary power instead of engine power.
18. Ground Controls - Place Ground/Platform Select switch to Ground. Start engine. Platform controls should not operate.

SkyGuard Function Test

NOTE: Refer to Section 4.10 for additional information on SkyGuard operation.

From the Platform Console in an area free from obstructions:

1. Operate the telescope out function.
2. Activate the SkyGuard sensor:
 - a. **SkyGuard** - Apply approximately 50 lb (222 Nm) of force to yellow bar.
 - b. **SkyGuard - SkyLine** - Press cable to break magnetic connection between the cable and right bracket.
 - c. **SkyGuard - SkyEye** - Put arm or hand in path of sensor beam.
3. Once the sensor has been activated, verify the following conditions:
 - a. Telescope out function stops and telescope in function operates for a short duration.
 - b. The horn sounds.
 - c. If equipped with a SkyGuard beacon, the beacon illuminates.

SECTION 2 - USER RESPONSIBILITIES, MACHINE PREPARATION, AND INSPECTION

NOTE: If SkyGuard is enabled with the Soft Touch system, functions will cut out instead of reversing.

4. Disengage the SkyGuard sensor, release controls, then recycle the footswitch. Ensure normal operation is available.

NOTE: On machines equipped with SkyLine, reattach magnetic end of the cable to the bracket.

If SkyGuard remains activated after function reversal or cutout, depress and hold the SkyGuard Override Switch to allow normal use of machine functions until the sensor is disengaged.

2.4 OSCILLATING AXLE LOCKOUT TEST (IF EQUIPPED)

NOTICE

LOCKOUT SYSTEM TEST MUST BE PERFORMED QUARTERLY, ANY TIME A SYSTEM COMPONENT IS REPLACED, OR WHEN IMPROPER SYSTEM OPERATION IS SUSPECTED.

NOTE: Ensure boom is fully retracted, lowered, and centered between drive wheels prior to beginning lockout cylinder test.

1. Place a 6 inch (15.2 cm) high block with ascension ramp in front of left front wheel.
2. From platform control station, start engine.
3. Position Drive Speed/Torque Select switch to Slow.
4. Place Drive control lever to Forward position and carefully drive machine up ascension ramp until left front wheel is on top of block.
5. Carefully activate Swing control lever and position boom over Right side of machine.
6. With boom over right side of machine, place Drive control lever to Reverse and drive machine off of block and ramp.
7. Have an assistant check to see that left front or right rear wheel remains elevated in position off of ground.

SECTION 2 - USER RESPONSIBILITIES, MACHINE PREPARATION, AND INSPECTION

8. Carefully activate Swing control lever and return boom to stowed position (centered between drive wheels). When boom reaches center, stowed position, lockout cylinders should release and allow wheel to rest on ground, it may be necessary to activate Drive to release cylinders.
9. Place the 6 inch (15.2 cm) high block with ascension ramp in front of right front wheel.
10. Place Drive control lever to Forward and carefully drive machine up ascension ramp until right front wheel is on top of block.
11. Carefully activate SWING control lever and position boom over left side of machine.
12. With boom over left side of machine, place DRIVE control lever to REVERSE and drive machine off of block and ramp.
13. Have an assistant check to see that right front or left rear wheel remains elevated in position off of ground.
14. Carefully activate SWING control lever and return boom to stowed position (centered between drive wheels). When boom reaches center, stowed position, lockout cylinders should release and allow wheel to rest on ground, it may be necessary to activate DRIVE to release cylinders.
15. If lockout cylinders do not function properly, have qualified personnel correct the malfunction prior to any further operation.

SECTION 3. MACHINE CONTROLS AND INDICATORS

3.1 GENERAL

NOTICE

THE MANUFACTURER HAS NO DIRECT CONTROL OVER MACHINE APPLICATION AND OPERATION. THE USER AND OPERATOR ARE RESPONSIBLE FOR CONFORMING WITH GOOD SAFETY PRACTICES.

This section provides the necessary information needed to understand control functions.

3.2 CONTROLS AND INDICATORS

NOTE: All machines are equipped with control panels that use symbols to indicate control functions. On ANSI machines refer to decal located on the control box guard in front of the control box or by the ground controls for these symbols and the corresponding functions.

NOTE: The indicator panels use different shaped symbols to alert the operator to different types of operational situations that could arise. The meaning of those symbols are explained below.



Indicates a potentially hazardous situation, which if not corrected, could result in serious injury or death. This indicator will be red.



Indicates an abnormal operating condition, which if not corrected, may result in machine interruption or damage. This indicator will be yellow.



Indicates important information regarding the operating condition, i.e. procedures essential for safe operation. This indicator will be green with the exception of the capacity indicator which will be green or yellow depending upon platform position.

⚠ WARNING

TO AVOID SERIOUS INJURY, DO NOT OPERATE MACHINE IF ANY CONTROL LEVERS OR TOGGLE SWITCHES CONTROLLING PLATFORM MOVEMENT DO NOT RETURN TO THE OFF POSITION WHEN RELEASED.

Ground Control Console

See Figure 3-1., Ground Control Console and Figure 3-2., Ground Control Console with Machine Safety System Override (MSSO) (CE Only).

NOTE: If equipped, the Function Enable switch must be held down in order to operate Main Boom Telescope, Tower Lift, Swing, Main Lift, Jib Lift, Platform Level Override, and Platform Rotate functions.



1. Platform Rotate

Provides rotation of the platform.

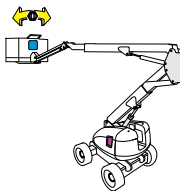

⚠ WARNING

ONLY USE THE PLATFORM LEVELING OVERRIDE FUNCTION FOR SLIGHT LEVELING OF THE PLATFORM. INCORRECT USE COULD CAUSE THE LOAD/OCCUPANT TO SHIFT OR FALL. FAILURE TO DO SO COULD RESULT IN DEATH OR SERIOUS INJURY.

2. Platform Leveling Override

A three position switch allows the operator to adjust the automatic self leveling system. This switch is used to adjust platform level in situations such as ascending/descending a grade.

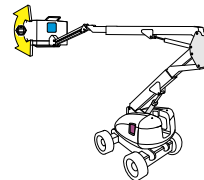

3. Jib (If Equipped)

This switch provides raising and lowering of the jib.

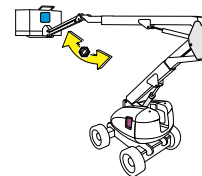

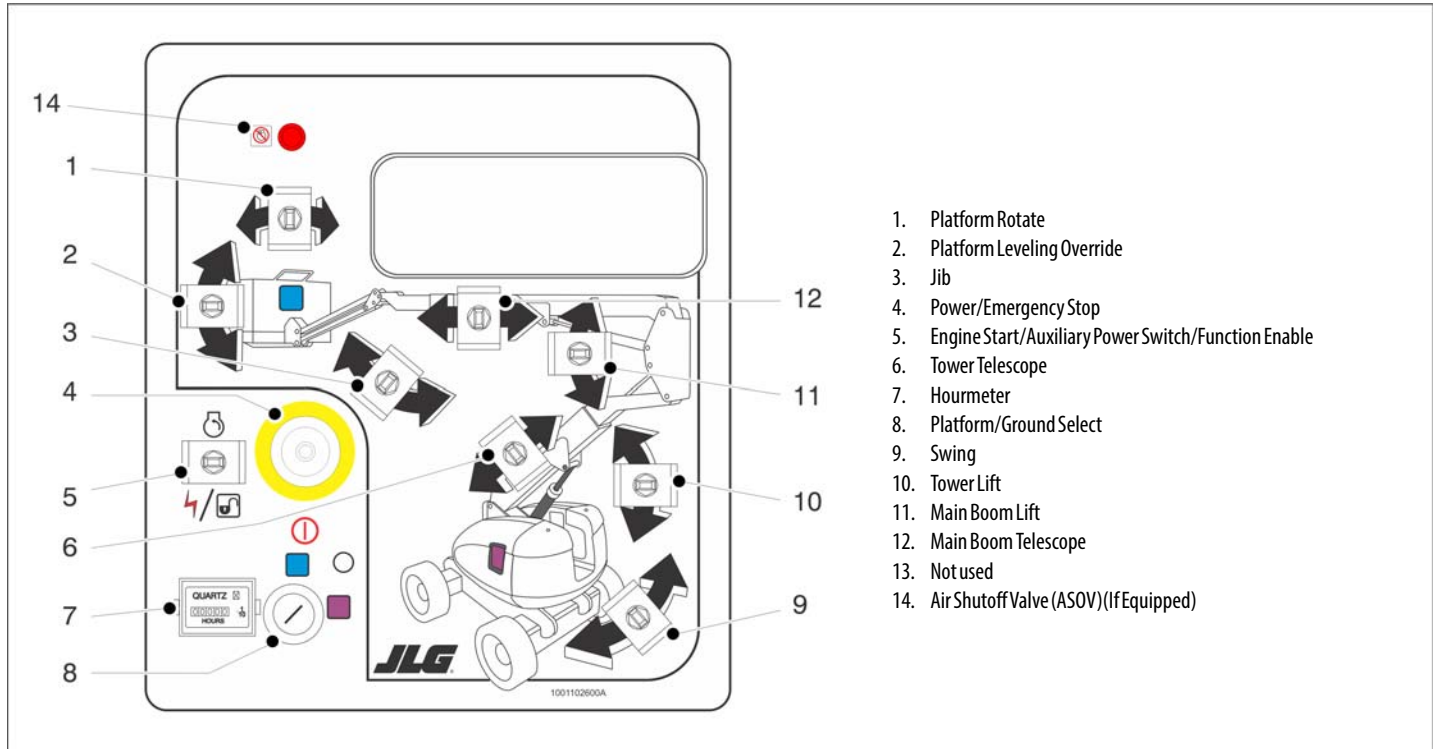

1. Platform Rotate
2. Platform Leveling Override
3. Jib
4. Power/Emergency Stop
5. Engine Start/Auxiliary Power Switch/Function Enable
6. Tower Telescope
7. Hourmeter
8. Platform/Ground Select
9. Swing
10. Tower Lift
11. Main Boom Lift
12. Main Boom Telescope
13. Not used
14. Air Shutoff Valve (ASOV) (If Equipped)

Figure 3-1. Ground Control Console

SECTION 3 - MACHINE CONTROLS AND INDICATORS

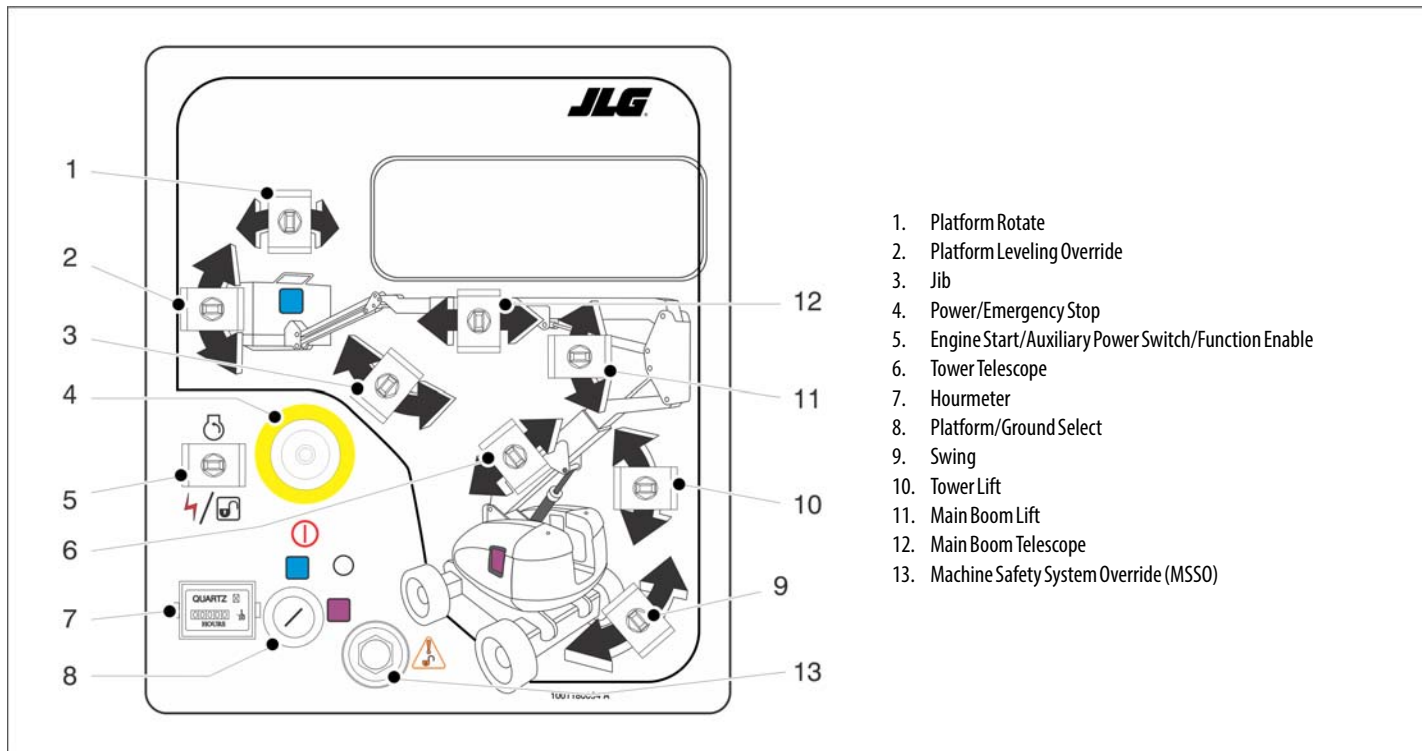

Figure 3-2. Ground Control Console with Machine Safety System Override (MSSO) (CE Only)

SECTION 3 - MACHINE CONTROLS AND INDICATORS

NOTE: When Power/Emergency Stop switch is in the "On" position and engine is not running, an alarm will sound, indicating Ignition is "On".

CAUTION

WHEN THE MACHINE IS SHUT DOWN THE MASTER/EMERGENCY STOP SWITCH MUST BE POSITIONED TO THE "OFF" POSITION TO PREVENT DRAINING THE BATTERY.

NOTE: On machines with diesel engines, when Glow Plug Indicator is lighted (Yellow), wait until light goes out before cranking engine.

4. Power/Emergency Stop Switch

A two-position red mushroom shaped switch supplies power to Platform/Ground Select switch when pulled out (on). When pushed in (off), power is shut off to the Platform/Ground Select switch.



5. Engine Start/ Auxiliary Power Switch /Function Enable



To start the engine, the switch must be held "Up" until the engine starts.

To use auxiliary power, the switch must be held "Down" for duration of auxiliary pump use.



When the engine is running, the switch must be held "Down" to enable all boom controls.



CAUTION

WHEN OPERATING ON AUXILIARY POWER, DO NOT OPERATE MORE THAN ONE FUNCTION AT A TIME. (SIMULTANEOUS OPERATION CAN OVERLOAD THE AUXILIARY PUMP MOTOR.)

SECTION 3 - MACHINE CONTROLS AND INDICATORS

6. Tower Telescope

This switch provides extending and retracting of the tower boom. This function works only when the tower boom is fully elevated (lift up).

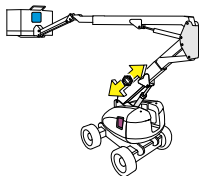

⚠ WARNING

TO AVOID UPSET AND SERIOUS INJURY, DO NOT OPERATE MACHINE IF TOWER LIFT AND TELESCOPE FUNCTIONS DO NOT OPERATE IN THE ABOVE SEQUENCE.

7. Hourmeter

Registers the amount of time the machine has been in use, with engine running. By connecting into the oil pressure circuit of the engine, only engine run hours are recorded. The hourmeter registers up to 9,999.9 hours and cannot be reset.

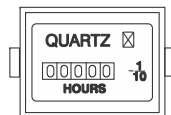

NOTE: When the Platform/Ground Select Switch is in the center position, power is shut off to the controls at both operating stations. Remove the key to prevent the controls from being actuated. The key is removable in the platform position on CE specification machines. The key must be available to ground personnel in the event of an emergency.



8. Platform/Ground Select Switch

The three position, key operated switch supplies power to the platform control console when positioned to Platform. With the switch key turned to the Ground position only ground controls are operable.

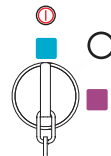

SECTION 3 - MACHINE CONTROLS AND INDICATORS

NOTE: Main Lift, Tower Lift, Swing, Platform Level, Main Telescope, Tower Telescope, Platform Rotate, and Auxiliary Power control switches are spring-loaded and will automatically return to neutral (off) when released.

WARNING

WHEN OPERATING THE BOOM ENSURE THERE ARE NO PERSONNEL AROUND OR UNDER PLATFORM.

WARNING

TO AVOID SERIOUS INJURY, DO NOT OPERATE MACHINE IF ANY CONTROL LEVERS OR TOGGLE SWITCHES CONTROLLING PLATFORM MOVEMENT DO NOT RETURN TO THE OFF POSITION WHEN RELEASED.

9. Swing Control

Provides 360 degrees continuous turntable rotation.

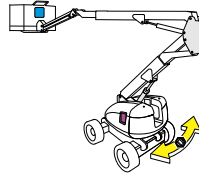

10. Tower Lift

This switch provides raising and lowering of the tower boom. This function works only when the tower boom is fully retracted.

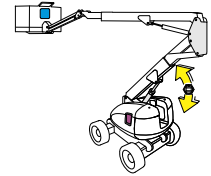

11. Main Boom Lift Control

Provides raising and lowering of the main boom.

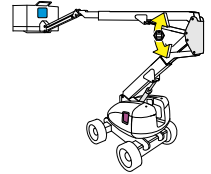

12. Main Telescope Control

Provides extension and retraction of the main boom.

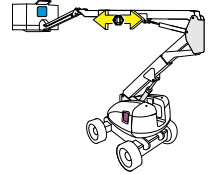

SECTION 3 - MACHINE CONTROLS AND INDICATORS

13. Machine Safety System Override (MSSO) (CE Only)

Provides emergency override of function controls that are locked out in the event of Load Sense System activation.



14. Air Shutoff Valve (ASOV) (If Equipped)

The red LED ASOV light indicate when the valve has been actuated.



Ground Control Indicator Panel

(See Figure 3-3., Ground Control Indicator Panel)

1. No Alternator Output Indicator

Indicates a problem in the charging circuit, and service is required.



2. Engine Oil Pressure Indicator

Indicates that engine oil pressure is below normal and service is required.



3. High Engine Coolant Temperature Indicator (Liquid Cooled Engines)

Indicates that engine coolant temperature is abnormally high and service is required.



4. Engine Oil Temperature Indicator (Deutz, If Equipped)

Indicates that the temperature of the engine oil, which also serves as engine coolant, is abnormally high and service is required.



5. Glow Plug/ Wait to Start Indicator

Indicates the glow plugs are on. The glow plugs are automatically turned on with the ignition circuit and remain on for approximately seven seconds. Start the engine only after the light goes out.



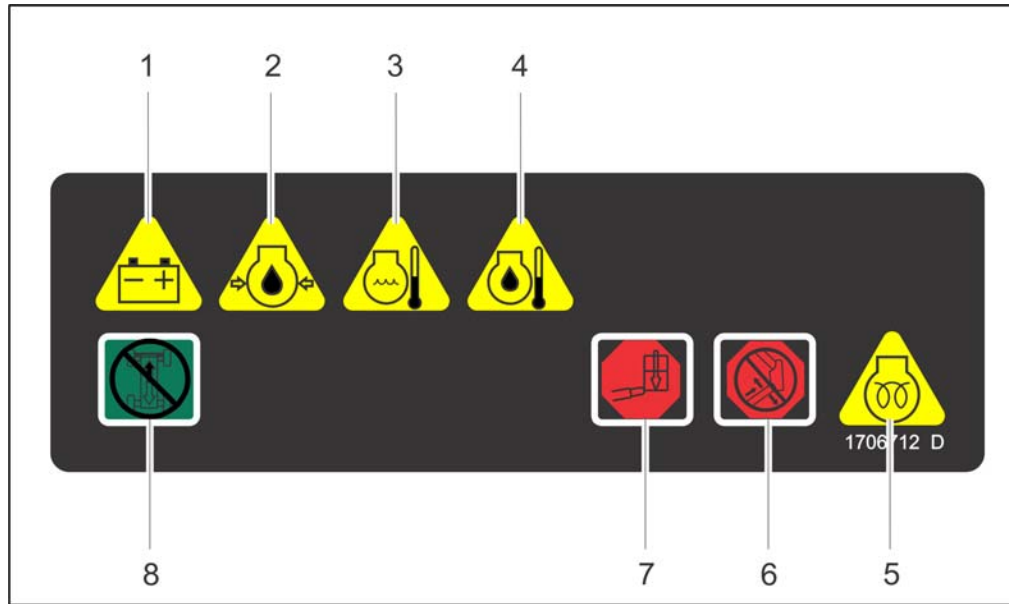

- | | | |
|------------------------------------|--------------------------------|----------------------------|
| 1. No Alternator Output | 4. High Engine Oil Temperature | 7. Platform Overload |
| 2. Low Engine Oil Pressure | 5. Glow Plug | 8. Drive and Steer Disable |
| 3. High Engine Coolant Temperature | 6. Boom Malfunction | |

Figure 3-3. Ground Control Indicator Panel

SECTION 3 - MACHINE CONTROLS AND INDICATORS

6. Boom Malfunction Indicator



If the Boom Malfunction Indicator illuminates when attempting to activate a tower boom function, the function is being cutout by tower boom limit switch. The function is not permitted at the current boom configuration.

If the Boom Malfunction Indicator is flashing or on steady without a boom function attempt, the upright is out of alignment or the monitoring system is in need of calibration.

⚠ WARNING

DISCONTINUE OPERATION IF THE BOOM MALFUNCTION LIGHT IS FLASHING OR ON STEADY.

NOTICE

IF THE UPRIGHT IS OUT OF ALIGNMENT WITH THE PLATFORM RAISED, LOWER THE MAIN BOOM AND TELESCOPE OUT UNTIL THE PLATFORM REACHES THE GROUND. THE TOWER BOOM DOWN FUNCTION IS CUT OUT IN THIS CONDITION. REPORT THE PROBLEM TO THE PROPER SERVICE PERSONNEL. DO NOT OPERATE THE MACHINE UNTIL THE MALFUNCTION IS CORRECTED.

7. Platform Overload Indicator. (If Equipped)

Indicates the platform has been overloaded.



8. Drive and Steer Disable Indicator (If equipped)

Indicates the Drive and Steer Disable function has been activated.



Platform Console

(See Figure 3-4.)

⚠ WARNING

TO AVOID SERIOUS INJURY, DO NOT OPERATE MACHINE IF ANY CONTROL LEVERS OR TOGGLE SWITCHES CONTROLLING PLATFORM MOVEMENT DO NOT RETURN TO THE OFF OR NEUTRAL POSITION WHEN RELEASED.

1. Drive Speed/Torque Select

The machine has a two position switch - The forward position gives maximum drive speed. The back position gives maximum torque for rough terrain and climbing grades.

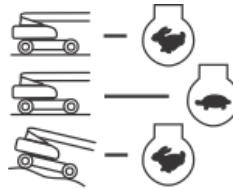

2. Steer Select (If Equipped)

When equipped with four wheel steering, the action of the steering system is operator selectable. The center switch position gives conventional front wheel steering with the rear wheels unaffected. This is for normal driving at maximum speeds. The forward position is for “crab” steering. When in this mode both front and rear axles steer in the same direction, which allows the chassis to move sideways as it goes forward. This can be used for positioning the machine in aisle ways or against buildings. The back switch position is for “coordinated” steering. In this mode the front and rear axles steer in the opposite directions to produce the tightest turning circle for maneuvering in confined areas.

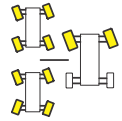

To re-synchronize the front and rear axles, position the rear drive wheels to the forward drive position by selecting either crab or compound steer, then select front steer (center switch position) to operate the normal steering function.

SECTION 3 - MACHINE CONTROLS AND INDICATORS

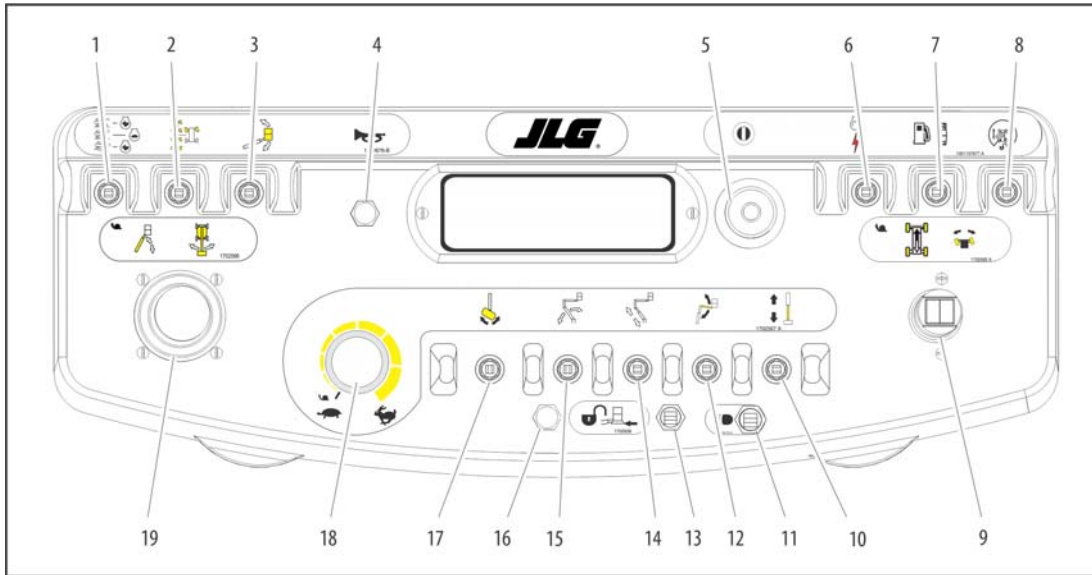

- | | | | |
|--------------------------------|-------------------------------|----------------------------------|-----------------------------------|
| 1. Drive Speed / Torque Select | 6. Engine Start / Aux Power | 11. Lights | 16. Soft Touch/SkyGuard Indicator |
| 2. Steer Select | 7. Fuel Select | 12. Jib (800AJ) | 17. Platform Rotate |
| 3. Platform Level Override | 8. Drive Orientation Override | 13. Soft Touch/SkyGuard Override | 18. Function Speed Control |
| 4. Horn | 9. Drive/Steer | 14. Tower Telescope | 19. Main Lift / Swing |
| 5. Power/Emergency Stop | 10. Telescope | 15. Tower Lift | |

Figure 3-4. Platform Control Console

WARNING

ONLY USE THE PLATFORM LEVELING OVERRIDE FUNCTION FOR SLIGHT LEVELING OF THE PLATFORM. INCORRECT USE COULD CAUSE THE LOAD/OCCUPANTS TO SHIFT OR FALL. FAILURE TO DO SO COULD RESULT IN DEATH OR SERIOUS INJURY.

3. Platform Leveling Override

A three position switch allows the operator to adjust the automatic self leveling system. This switch is used to adjust platform level in situations such as ascending/descending a grade.



4. Horn

A push-type Horn switch supplies electrical power to an audible warning device when pressed.



5. Power/Emergency Stop Switch

A two-position red mushroom shaped switch furnishes power to Platform Controls when pulled out (on). When pushed in (off), power is shut off to the platform functions.



6. Engine Start/Auxiliary Power

When pushed forward, the switch energizes the starter motor to start the engine.



The Auxiliary Power control switch energizes the electrically operated hydraulic pump. (Switch must be held on for duration of auxiliary pump use.)



The auxiliary pump functions to provide sufficient oil flow to operate the basic machine functions should the main pump or engine fail. The auxiliary pump will operate tower boom lift, tower telescope, main boom lift, main telescope and swing.

7. Fuel Select (Dual Fuel Engine Only) (If Equipped)

Gasoline or liquid propane fuel may be selected by moving the switch to the appropriate position. It is unnecessary to purge the fuel system before switching fuels, so there is no waiting period when switching fuels while the engine is running.



SECTION 3 - MACHINE CONTROLS AND INDICATORS

8. Drive Orientation Override

When the boom is swung over the rear tires or further in either direction, the Drive Orientation indicator will illuminate when the drive function is selected. Push and release the switch, and within 3 seconds move the Drive/Steer control to activate drive or steer. Before driving, locate the black/white orientation arrows on both the chassis and the platform controls. Move the drive controls in a direction matching the directional arrows.



NOTE: Lift, Swing, and Drive control levers are spring-loaded and will automatically return to neutral (off) position when released.

⚠ WARNING

TO AVOID SERIOUS INJURY, DO NOT OPERATE MACHINE IF ANY CONTROL LEVERS OR TOGGLE SWITCHES CONTROLLING PLATFORM MOVEMENT DO NOT RETURN TO THE OFF OR NEUTRAL POSITION WHEN RELEASED.

NOTE: To operate the Drive joystick, pull up on the locking ring below the handle.

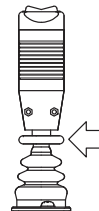

NOTE: The Drive joystick is spring loaded and will automatically return to neutral (off) position when released.

9. Drive/Steer

Push forward to drive forward, pull back to drive in reverse. Steering is accomplished via a thumb-activated rocker switch on the end of the steer handle.

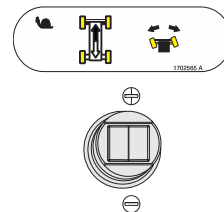

10. Main Boom Telescope

Provides extension and retraction of the main boom.

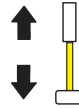

11. Lights (If Equipped)

This switch operates control console panel lights and head lights if the machine is so equipped. The ignition switch does not have to be on to operate the lights, so care must be taken to avoid draining the battery if left unattended. The master switch and / or the ignition switch at the ground control will turn off power to all lights.



12. Jib (If Equipped)

Push forward to lift up, pull back to lift down. Variable lift speed is using the Function Speed Control.



13. Soft Touch/SkyGuard Override Switch (If equipped)

The machine can be equipped with one of three options. It may have Soft Touch, SkyGuard, or both Soft Touch and SkyGuard.

If equipped with Soft Touch, the switch enables the functions that were cut out by the Soft Touch system to operate again at creep speed, allowing the operator to move the platform away from the obstacle that caused the shutdown situation.



If equipped with SkyGuard, the switch enables functions cut out by the SkyGuard system to be operated again, allowing the operator to resume use of machine functions.



If equipped with both Soft Touch and SkyGuard, the switch operates like described above and allows the operator to override the system that has experienced a cutout situation.



SECTION 3 - MACHINE CONTROLS AND INDICATORS

14. Tower Telescope

This switch provides for extending and retracting of the tower boom when positioned to in or out. Tower Telescope must be fully retracted before operating Tower Lift. (Tower Telescope should not function when Tower Lift is not fully elevated “up”).

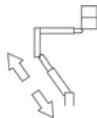

⚠ WARNING

TO AVOID UPSET AND SERIOUS INJURY, DO NOT OPERATE MACHINE IF TOWER LIFT AND TELESCOPE DO NOT OPERATE IN THE ORDER DESCRIBED ABOVE.

15. Tower Lift

This switch provides for raising and lowering of the tower boom when positioned to “up” or “down”. Tower Lift must be fully elevated “up” before operating Tower Telescope. (Tower Lift should not function when Tower Telescope is extended).



16. Soft Touch/SkyGuard Indicator (If Equipped)

Indicates the Soft Touch bumper is against an object or the SkyGuard sensor has been activated. All controls are cut out until the override button is pushed. For Soft Touch, controls are then active in the Creep Mode or for SkyGuard, controls will work normally.

17. Platform Rotate

Provides rotation of the platform when positioned to the right or left.



18. Function Speed Control

This control affects the speed of telescope and platform rotate. Turning the knob all the way counterclockwise until it clicks puts drive, main lift and swing into creep mode.



NOTE: To operate the Main Boom Lift/Swing joystick, pull up on the locking ring below the handle.

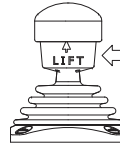

NOTE: The Main Boom Lift/Swing joystick is spring loaded and will automatically return to neutral (off) position when released.

19. Main Lift/Swing Controller

Provides main lift and swing. Push forward to lift up, pull backward to boom down. Move right to swing right, move left to swing left. Moving the joystick activates switches to provide the functions selected.

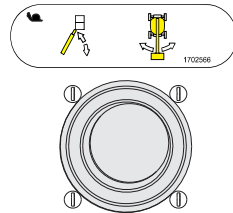

NOTE: Main boom lift and swing functions may be selected in combination. Maximum speed is reduced when multiple functions are selected.

Platform Console Indicator Panel

(See Figure 3-5., Platform Console Indicator Panel)

1. Tilt Alarm Warning Light and Alarm



This illuminator indicates that the chassis is on a slope. An alarm will also sound when the chassis is on a slope and the boom is above horizontal. If lit when boom is raised or extended, retract and lower to below horizontal then reposition machine so that it is level before continuing operation. If the boom is above horizontal and the machine is on a slope, the tilt alarm warning light will illuminate and an alarm will sound and CREEP is automatically activated.

⚠ WARNING

IF TILT WARNING LIGHT IS ILLUMINATED WHEN BOOM IS RAISED OR EXTENDED, RETRACT AND LOWER TO BELOW HORIZONTAL THEN REPOSITION MACHINE SO THAT IT IS LEVEL BEFORE EXTENDING BOOM OR RAISING BOOM ABOVE HORIZONTAL.

NOTE: *In certain markets, when the tilt sensor alarm is activated the Drive function will be disabled if the boom is elevated above horizontal.*

2. Platform Overload (If equipped)

Indicates the platform has been overloaded.



3. Boom Malfunction Indicator

When an audible alarm sounds and the Boom Malfunction Indicator illuminates when attempting to activate a tower boom function, the function is being cutout by tower boom limit switch. This function is not permitted at the current boom configuration.



When an audible alarm sounds and the Boom Malfunction Indicator illuminates steady without a boom function attempt, the upright is out of alignment.

⚠ WARNING

DISCONTINUE OPERATION IF THE UPRIGHT IS OUT OF ALIGNMENT OR THE BOOM MALFUNCTION LIGHT REMAINS ILLUMINATED.

NOTICE

IF THE UPRIGHT IS OUT OF ALIGNMENT WITH THE PLATFORM RAISED, LOWER THE MAIN BOOM AND TELESCOPE OUT UNTIL THE PLATFORM REACHES THE GROUND. THE TOWER BOOM DOWN FUNCTION IS CUT OUT IN THIS CONDITION. REPORT THE PROBLEM TO THE PROPER SERVICE PERSONNEL. DO NOT OPERATE THE MACHINE UNTIL THE CONDITION IS CORRECTED.

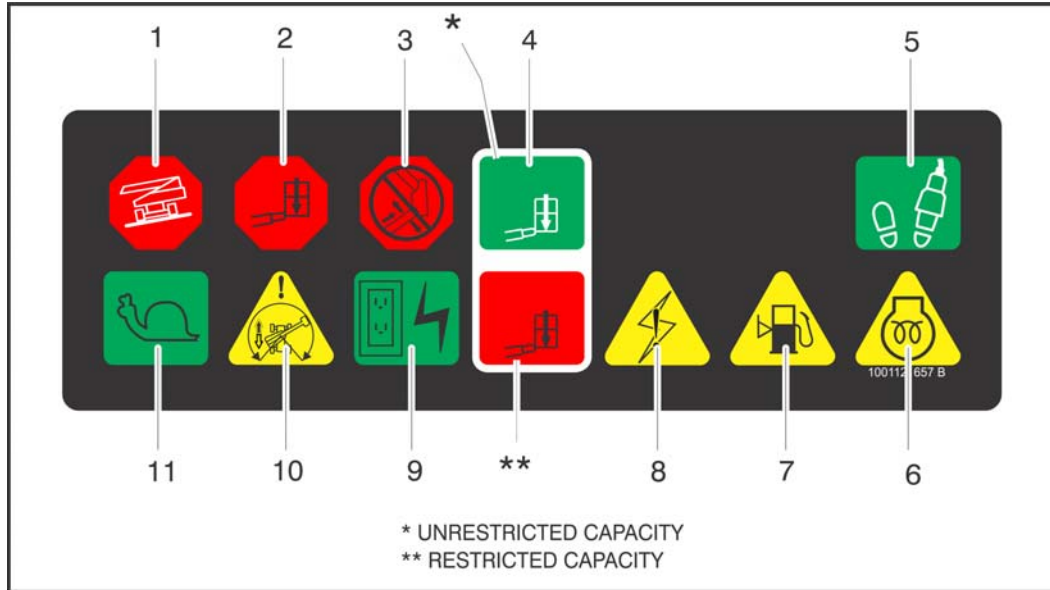

- | | | |
|---------------------|--------------------|-----------------------|
| 1. Tilt | 5. Enable | 9. ACGenerator |
| 2. Overload | 6. Glow Plug | 10. Drive Orientation |
| 3. Boom Malfunction | 7. Low Fuel | 11. Creep |
| 4. Capacity | 8. System Distress | |

Figure 3-5. Platform Console Indicator Panel

SECTION 3 - MACHINE CONTROLS AND INDICATORS

4. Capacity Indicator

Indicates the maximum platform capacity for the current position of the platform. Restricted capacities are permitted at restricted platform positions (shorter boom lengths and higher boom angles).



NOTE: Refer to the capacity decals on the machine for restricted and unrestricted platform capacities.

5. Footswitch/Enable Indicator

To operate any function, the footswitch must be depressed and the function selected within seven seconds. The enable indicator shows that the controls are enabled. If a function is not selected within seven seconds, or if a seven second lapse between ending one function and beginning the next function, the enable light will go out and the footswitch must be released and depressed again to enable the controls.



Releasing the footswitch removes power from all controls and applies the drive brakes.

⚠ WARNING

TO AVOID SERIOUS INJURY, DO NOT REMOVE, MODIFY OR DISABLE THE FOOTSWITCH BY BLOCKING OR ANY OTHER MEANS.

⚠ WARNING

FOOTSWITCH MUST BE ADJUSTED IF FUNCTIONS ACTIVATE WHEN SWITCH ONLY OPERATES WITHIN LAST 1/4" OF TRAVEL, TOP OR BOTTOM.

SECTION 3 - MACHINE CONTROLS AND INDICATORS

6. Glow Plug/Wait to Start Indicator

Indicates the glow plugs are operating. After turning on ignition, wait until light goes out before cranking engine.



7. Low Fuel Indicator (Yellow)

Indicates the fuel tank is 1/8 full or less. When the light first turns on, there are approximately four usable gallons of fuel remaining.



8. System Distress Indicator

The light indicates that the JLG Control System has detected an abnormal condition and a Diagnostic Trouble Code has been set in the system memory. Refer to the Service Manual for instructions concerning the trouble codes and trouble code retrieval.



9. AC Generator (If Equipped)

Indicates the generator is in operation.



10. Drive Orientation Indicator

When the boom is swung beyond the rear drive tires or further in either direction, the Drive Orientation indicator will illuminate when the drive function is selected. This is a signal for the operator to verify that the drive control is being operated in the proper direction (i.e. controls reversed situations).



11. Creep Speed Indicator

When the Function Speed Control is turned to the creep position, the indicator acts as a reminder that all functions are set to the slowest speed.



SECTION 3 - MACHINE CONTROLS AND INDICATORS

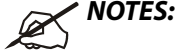

NOTES:

SECTION 4. MACHINE OPERATION

4.1 DESCRIPTION

This machine is a self-propelled hydraulic personnel lift equipped with a work platform on the end of an elevating and rotating boom.

The primary operator control station is in the platform. From this control station, the operator can drive and steer the machine in both forward and reverse directions. The operator can raise or lower the boom or swing the boom to the left or right. Standard boom swing is 360 degree continuous rotation. The machine has a Ground Control Station which will override the Platform Control Station. Ground Controls operate Boom Lift and Swing, and are to be used in an emergency to lower the platform to the ground should the operator in the platform be unable to do so.

4.2 BOOM OPERATING CHARACTERISTICS AND LIMITATIONS

Capacities

Raising boom above horizontal with or without any load in platform, is based on the following criteria:

1. Machine is positioned on a smooth, firm and level surface.

2. Load is within manufacturer's rated capacity.
3. All machine systems are functioning properly.
4. Proper tire pressure.
5. Machine is as originally equipped from JLG

Stability

Machine stability is based on two positions which are called FORWARD STABILITY and BACKWARD STABILITY. The machine position of least forward stability is shown in Figure 4-1. and its positions of least backward stability is shown in Figure 4-2. and Figure 4-3.

WARNING

TO AVOID FORWARD OR BACKWARD TIPPING, DO NOT OVERLOAD MACHINE OR OPERATE ON AN OUT-OF-LEVEL SURFACE.

SECTION 4 - MACHINE OPERATION

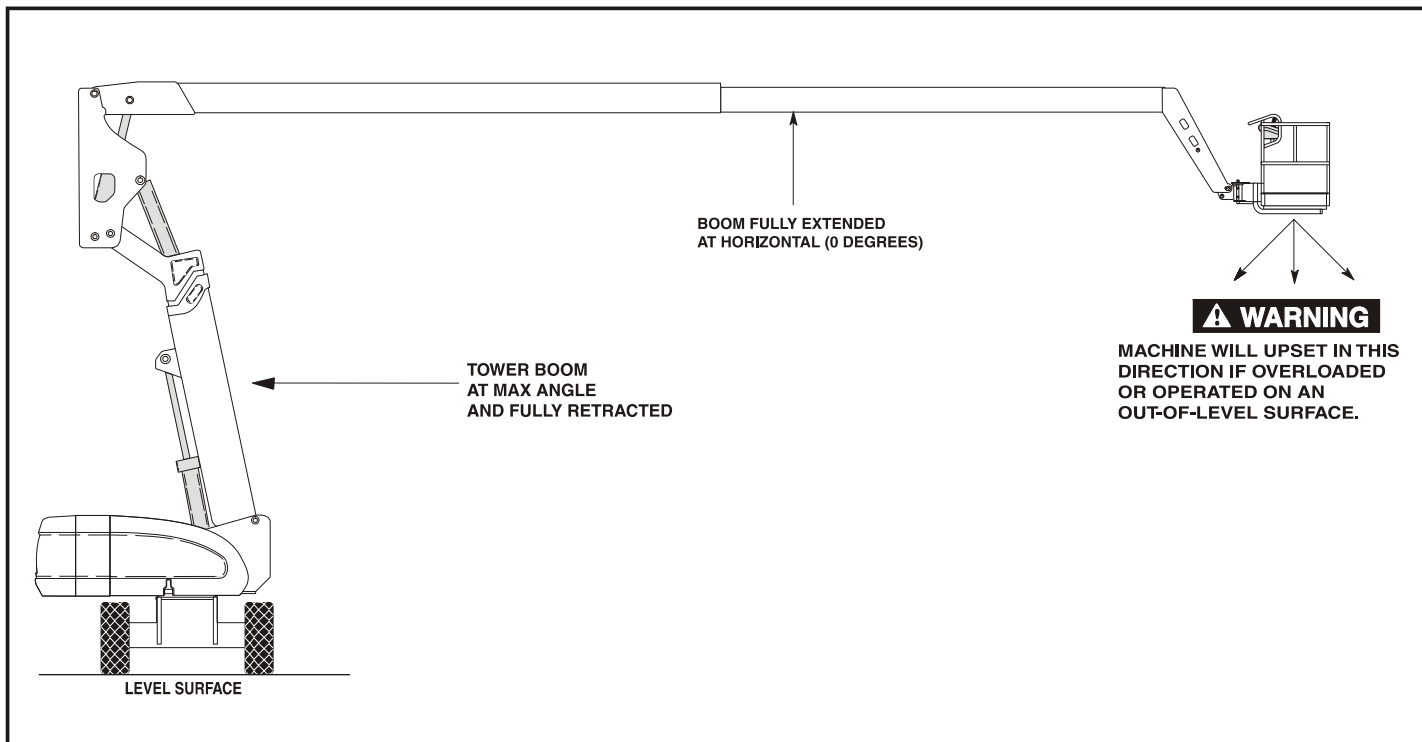

Figure 4-1. Position of Least Forward Stability

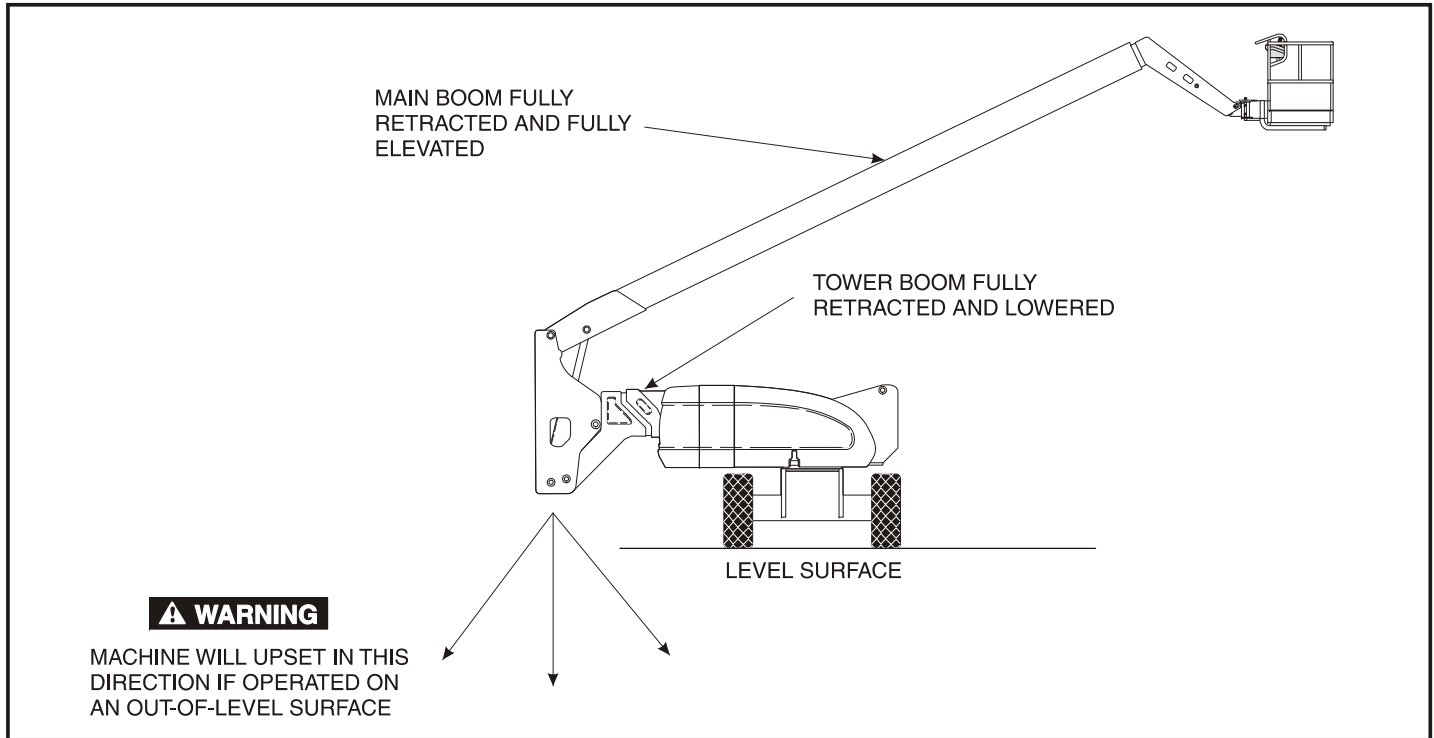

Figure 4-2. Positions of Least Backward Stability (Sheet 1 of 2)

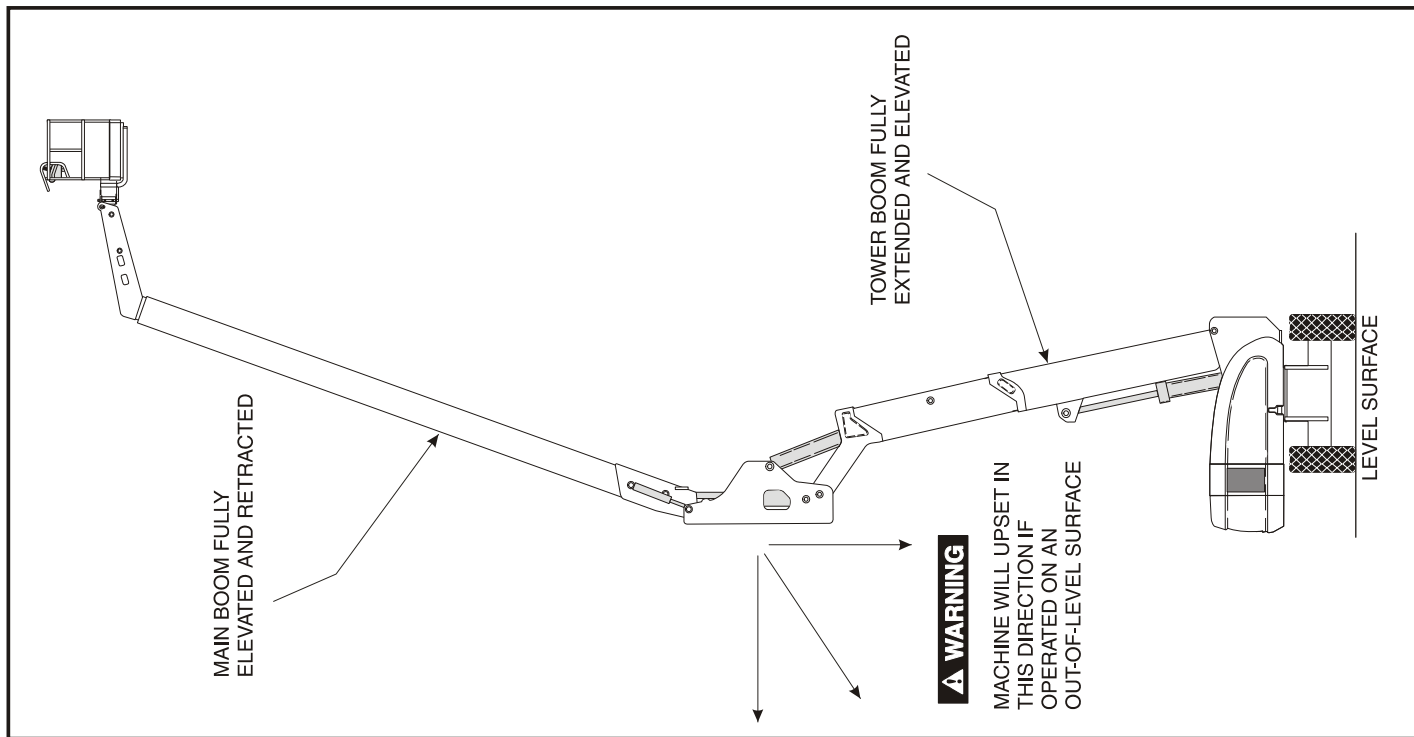
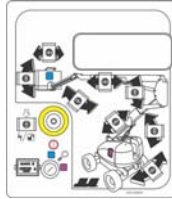

Figure 4-3. Positions of Least Backward Stability (Sheet 2 of 2)

4.3 ENGINE OPERATION

NOTE: Initial starting should always be performed from the Ground Control station.



Starting Procedure

CAUTION

IF ENGINE FAILS TO START PROMPTLY, DO NOT CRANK FOR AN EXTENDED TIME. SHOULD ENGINE FAIL TO START AGAIN, ALLOW STARTER TO “COOL OFF” FOR 2-3 MINUTES. IF ENGINE FAILS AFTER SEVERAL ATTEMPTS, REFER TO ENGINE MAINTENANCE MANUAL.

NOTE: Diesel engines only: After turning on ignition, operator must wait until glow plug indicator light goes out before cranking engine.



1. Turn key of Platform/Ground Select switch to Ground.



2. Pull the Power/Emergency Stop switch to On.



3. Push the Engine Start switch until engine starts.



CAUTION

ALLOW ENGINE TO WARM-UP FOR A FEW MINUTES AT LOW SPEED BEFORE APPLYING ANY LOAD.

4. After engine has had sufficient time to warm up, push in the Power/Emergency Stop switch and shut engine off.



5. Turn Platform/Ground Select switch to Platform.



6. From Platform, pull Power/Emergency Stop switch out.



SECTION 4 - MACHINE OPERATION

7. Push the Engine Start switch until engine starts.



NOTE: Footswitch must be in released (up) position before starter will operate. If starter operates with footswitch in the depressed position, DO NOT OPERATE MACHINE.

Shutdown Procedure

CAUTION

IF AN ENGINE MALFUNCTION CAUSES AN UNSCHEDULED SHUTDOWN, DETERMINE THE CAUSE AND CORRECT IT BEFORE RESTARTING THE ENGINE.

1. Remove all load and allow engine to operate at low speed for 3-5 minutes; this allows further reduction of internal engine temperature.
2. Push Power/Emergency Stop switch in.
3. Turn Platform/Ground Select switch to Off.

Refer to Engine Manufacturer's manual for detailed information.



Air Shutoff Valve (ASOV) (If Equipped)

Air Shutoff Valve (ASOV) is an overspeed protection device mounted to the engine's air intake system. When the valve is actuated, it obstructs airflow intake and stops the engine. Weekly tests are recommended to ensure the valve remains in good working condition.

1. Start the engine, running at idle.
2. Open the red switch guard on ASOV test switch, then activate toggle to test mode.

NOTE: Test switch is located under hood to the left of the ground control panel (look for test decal).



3. At the ground control panel, select any function and activate until valve actuates at test RPM of 1500. Once valve actuates, engine will stop.
4. Turn ignition to OFF.
5. Visually inspect valve to ensure it appears in good condition.
6. Reset valve by rotating valve handle to the Open position.

NOTE: The handle cannot be turned unless the machine is off. Ensure the ignition is moved to the OFF position.

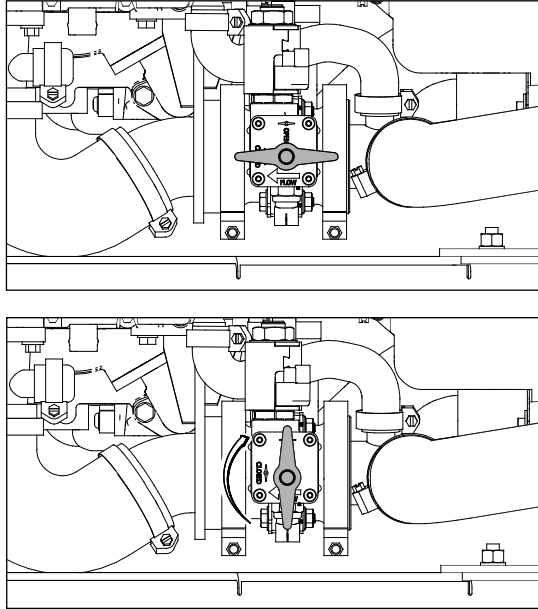
⚠ WARNING**DO NOT USE ASOV AS AN ALTERNATIVE TO SHUTTING DOWN MACHINE PROPERLY.****Figure 4-4. ASOV Reset (Closed to Open Position)****Fuel Reserve / Shut-Off System****NOTE:** Reference the Service and Maintenance Manual along with a qualified JLG Mechanic to verify your machine setup.

The Fuel Shutoff System monitors the fuel in the tank and senses when the fuel level is getting low. The JLG Control System automatically shuts the engine down before the fuel tank is emptied unless the machine is set up for Engine Restart.

If fuel level reaches the Empty range, the Low Fuel light will begin to flash once a second and there will be approximately 60 minutes of engine run time left. If the system is in this condition and automatically shuts down the engine or if the operator manually shuts down the engine before the 60 minute run time is complete, the Low Fuel light will flash 10 times a second and the engine will react according to machine setup. Setup options are as follows:



- Engine One Restart - When the engine shuts down, the operator will be permitted to cycle power and restart the engine once with approximately 2 minutes of run time. After the 2 minute run time is complete or if the engine is shut down by the operator prior to the completion of the 2 minute run time, it cannot be restarted until fuel is added to the tank.

- Engine Restart - When the engine shuts down, the operator will be permitted to cycle power and restart the engine for approximately 2 minutes of run time. After the 2 minutes of run time is complete, the operator may cycle power and restart the engine for an additional 2 minutes of run time. The operator can repeat this process until there is no more fuel available.

NOTICE

CONTACT A QUALIFIED JLG MECHANIC IF THE MACHINE NEEDS RESTARTED AFTER NO MORE FUEL IS AVAILABLE.

- Engine Stop - When the engine shuts down, no restarts will be permitted until fuel is added to the tank.

4.4 TRAVELING (DRIVING)

See Figure 4-5., Grade and Sideslopes

NOTE: *Refer to the Operating Specifications table for Gradeability and Sideslope ratings.*

All ratings for Gradeability and Sideslope are based upon the machine's boom being in the stowed position, fully lowered, and retracted.

Traveling is limited by two factors:

1. Gradeability, which is the percent of grade of the incline the machine can climb.
2. Sideslope, which is the angle of the slope the machine can be driven across.

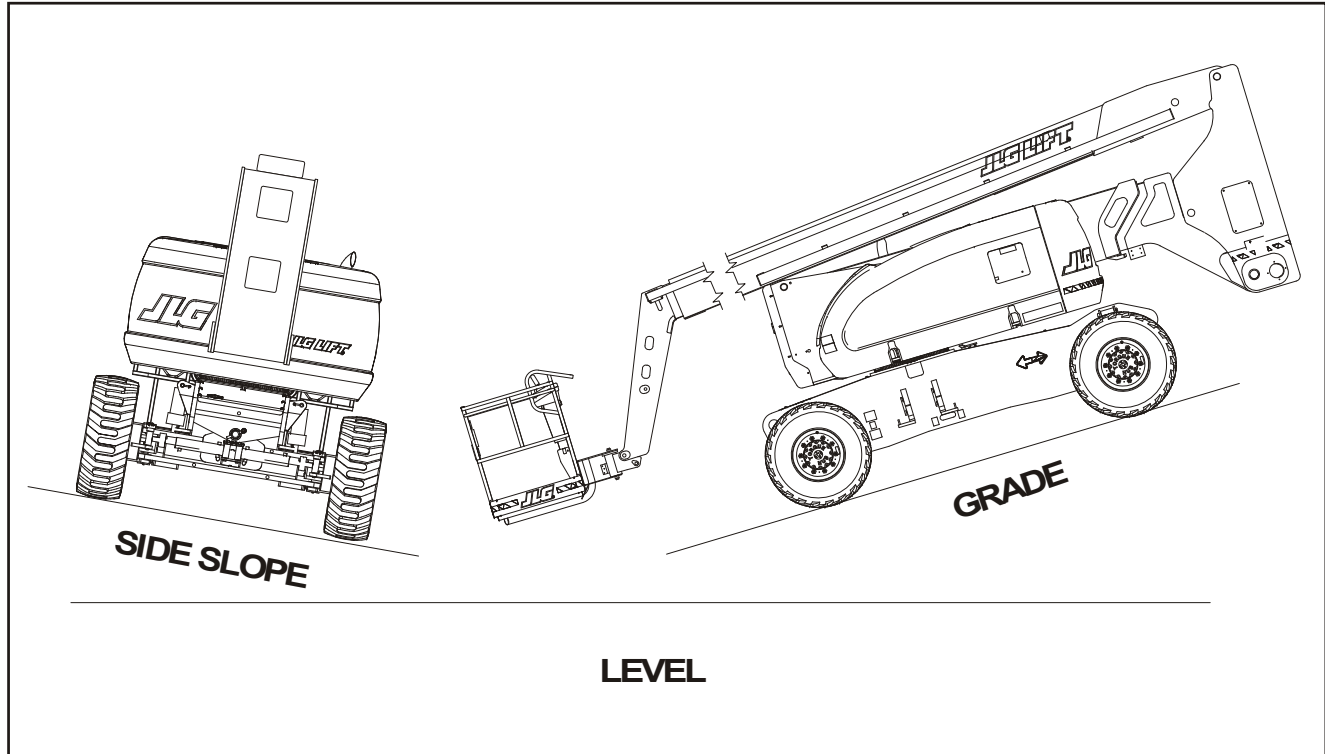

Figure 4-5. Grade and Sideslopes

⚠ WARNING

DO NOT DRIVE WITH BOOM ABOVE HORIZONTAL EXCEPT ON A SMOOTH, FIRM AND LEVEL SURFACE.

TO AVOID LOSS OF TRAVEL CONTROL OR "TIP OVER", DO NOT DRIVE MACHINE ON GRADES EXCEEDING THOSE SPECIFIED ON THE SERIAL NUMBER PLATE.

BE SURE THE TURNABLE LOCK IS ENGAGED BEFORE ANY EXTENDED TRAVELING.

DO NOT DRIVE ON SIDESLOPES WHICH EXCEED 5 DEGREES.

USE EXTREME CAUTION WHEN DRIVING IN REVERSE AND AT ALL TIMES WHEN THE PLATFORM IS ELEVATED.

BEFORE DRIVING, MAKE SURE BOOM IS POSITIONED OVER REAR DRIVE AXLE. IF BOOM IS OVER FRONT WHEELS, STEER AND DRIVE CONTROLS WILL BE REVERSED.

Traveling Forward and Reverse

1. At Platform Controls, pull out Emergency Stop switch and activate footswitch.
2. Position Drive controller to FORWARD or REVERSE as desired.

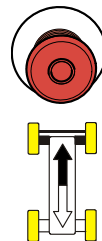

This machine is equipped with a Drive Orientation Indicator. The yellow light on the platform control console indicates that the boom is swung beyond the rear drive tires and the machine may Drive/Steer in the opposite direction from the movement of the controls. If the indicator is illuminated, operate the Drive function in the following manner:

1. Match the black and white direction arrows on both platform control panel and the chassis to determine the direction the machine will travel.

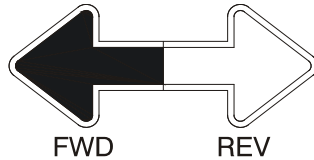

2. Push and release the Drive Orientation Override switch. Within 3 seconds, slowly move the Drive control toward the arrow matching the intended direction of machine travel. The indicator light will flash during the 3 second interval until the drive function is selected.



4.5 STEERING

Position thumb switch on Drive/Steer controller to Right for steering right, or to Left for steering left.



4.6 PLATFORM

Platform Level Adjustment

! WARNING

ONLY USE THE PLATFORM LEVELING OVERRIDE FUNCTION FOR SLIGHT LEVELING OF THE PLATFORM. INCORRECT USE COULD CAUSE THE LOAD/OCCUPANTS TO SHIFT OR FALL. FAILURE TO DO SO COULD RESULT IN DEATH OR SERIOUS INJURY.

To Level Up or Down - Position the Platform/Level control switch Up or Down and hold until the platform is level.

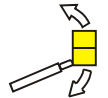

Platform Rotation

To rotate the platform to the left or right, use the Platform Rotate control switch to select the direction and hold until desired position is reached.



4.7 BOOM

WARNING

AN RED TILT ALARM WARNING LIGHT, LOCATED ON THE CONTROL CONSOLE, LIGHTS WHEN THE CHASSIS IS ON A SEVERE SLOPE. DO NOT SWING, EXTEND OR RAISE MAIN BOOM ABOVE HORIZONTAL WHEN LIT.

DO NOT DEPEND ON TILT ALARM AS A LEVEL INDICATOR FOR THE CHASSIS. CHASSIS MUST BE LEVEL BEFORE SWINGING, EXTENDING OR RAISING TOWER BOOM ABOVE HORIZONTAL.

TO AVOID UPSET, IF RED TILT ALARM WARNING LIGHT LIGHTS WHEN MAIN BOOM IS EXTENDED OR RAISED ABOVE HORIZONTAL, RETRACT AND LOWER PLATFORM TO NEAR GROUND LEVEL. THEN REPOSITION MACHINE SO THAT CHASSIS IS LEVEL BEFORE EXTENDING OR RAISING MAIN BOOM.

TRAVELING WITH MAIN BOOM RETRACTED AND BELOW HORIZONTAL IS PERMITTED ON GRADES AND SIDE SLOPES SPECIFIED ON THE SERIAL NUMBER PLACARD.

TO AVOID SERIOUS INJURY, DO NOT OPERATE MACHINERY IF ANY CONTROL LEVERS OR TOGGLE SWITCHES CONTROLLING PLATFORM MOVEMENT DO NOT RETURN TO THE OFF OR NEUTRAL POSITION WHEN RELEASED.

TO AVOID A COLLISION AND INJURY IF PLATFORM DOES NOT STOP WHEN A CONTROL SWITCH OR LEVER IS RELEASED, REMOVE FOOT FROM FOOTSWITCH OR USE EMERGENCY STOP TO STOP THE MACHINE.

Swinging the Boom

To swing boom, use Swing control switch to select Right or Left direction.



NOTICE

WHEN SWINGING THE BOOM MAKE SURE THERE IS AMPLE ROOM FOR THE BOOM TO CLEAR SURROUNDING WALLS, PARTITIONS AND EQUIPMENT.

NOTE: *On CE Market machines, when boom functions are being operated there is an interlock that prevents the use of Drive and Steer functions.*

Raising and Lowering the Tower Boom

This machine has two controls for the tower boom (two toggle switches), one controls tower lift, the other tower telescope. The switching system will sequence its Lift and Telescope functions as follows:

1. Sequence while raising the Tower Boom from the fully lowered position.

- a. The Tower Boom must be fully elevated “up” (approximately 12 degrees from vertical) before the Tower Boom can be extended from the fully retracted position.



- b. The Tower Telescope “out” or “in” will only be operable when the Tower Boom is fully elevated “up”.



2. Sequence while lowering the Tower Boom from the fully elevated “up” position.

- a. Operate Tower Telescope “in” until Tower Boom is fully retracted. (Tower must not lift “down until boom is telescoped “in” or “up” fully.



- b. The Tower lift “down” will only operate when the Tower Boom is fully retracted.



WARNING

TO AVOID TILTING MACHINE IF TOWER BOOM SWITCHING MALFUNCTIONS:

- LOWER PLATFORM TO GROUND USING MAIN BOOM LIFT AND TELESCOPE FUNCTIONS.
- HAVE CONDITION CORRECTED BY A CERTIFIED JLG SERVICE TECHNICIAN BEFORE CONTINUING USE OF MACHINE.

WARNING

DISCONTINUE OPERATION IF THE UPRIGHT IS OUT OF ALIGNMENT OR THE BOOM MALFUNCTION LIGHT REMAINS ILLUMINATED.

NOTICE

IF THE UPRIGHT IS OUT OF ALIGNMENT WITH THE PLATFORM RAISED, LOWER THE MAIN BOOM AND TELESCOPE OUT UNTIL THE PLATFORM REACHES THE GROUND. THE TOWER BOOM DOWN FUNCTION IS CUT OUT IN THIS CONDITION. REPORT THE PROBLEM TO THE PROPER SERVICE PERSONNEL. DO NOT OPERATE THE MACHINE UNTIL THE CONDITION IS CORRECTED.

Raising and Lowering the Main Boom

To raise or lower the Main Boom, position the Main Boom Lift switch to Up or Down until the desired height is reached.



Telescoping the Main Boom

To extend or retract the main boom, use the Main Telescope Control Switch to select In or Out movement.

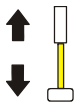

4.8 SHUT DOWN AND PARK

1. Drive machine to a protected area.
2. Assure boom is fully retracted and lowered over rear (Drive) axle; all access panels and doors closed and secured.
3. Remove all load and allow engine to operate 3-5 minutes at idle to permit reduction of engine internal temperatures.
4. At Ground Controls, turn Key Select switch to (center) Off Position, Power/Emergency Stop switch (down) to Off. Remove key.
5. Cover Platform Control console to protect instruction placards, warning decals and operating controls from hostile environment.

4.9 MACHINE SAFETY SYSTEM OVERRIDE (MSSO)(CE ONLY)

The Machine Safety System Override (MSSO) is used to override function controls for Emergency Platform Retrieval only. Refer to Section 5.5, MACHINE SAFETY SYSTEM OVERRIDE (MSSO)(CE ONLY) for operating procedures.



4.10 SKYGUARD OPERATION

SkyGuard provides enhanced control panel protection. When the SkyGuard sensor is activated, functions in use at the time of activation will reverse or cutout. The SkyGuard Function Table provides more details on these functions.

During activation, the horn will sound and, if equipped with a SkyGuard beacon, the beacon will illuminate until sensor and footswitch are disengaged.

If the SkyGuard sensor remains activated after function reversal or cutout, depress and hold the SkyGuard Override Switch to allow normal functions until the sensor is disengaged.

Consult the following illustrations to determine which type of SkyGuard the machine has. Regardless of type, SkyGuard function according to the SkyGuard Function Table does not change.

SkyGuard

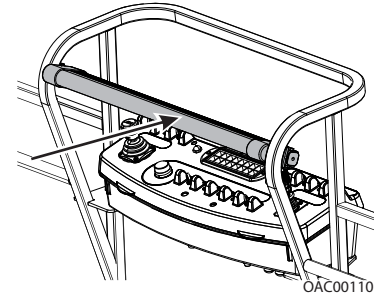

Approximately 50 lb (222 Nm) of force is applied to yellow bar.

SkyGuard - SkyLine

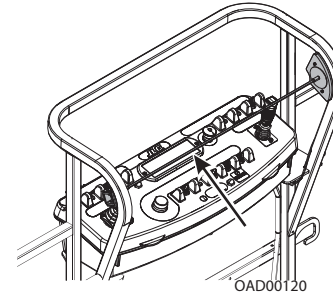

Cable is pressed, breaking the magnetic connection between the cable and right bracket.

SECTION 4 - MACHINE OPERATION

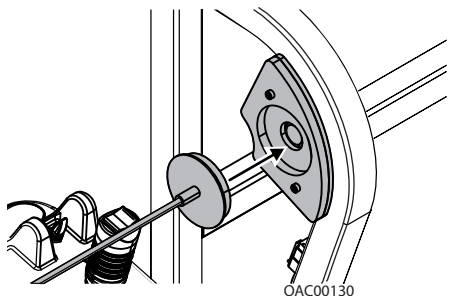

Reattach magnetic end of cable to bracket if it becomes disconnected.

SkyGuard - SkyEye

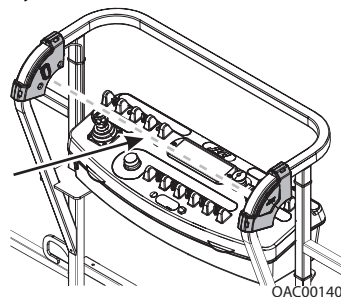

Operator passes through path of sensor beam.

SkyGuard Function Table

Drive Forward	Drive Reverse	Steer	Swing	Tower Lift Up	Tower Tele Out	Tower Lift Down	Tower Tele In	Boom Lift Up	Boom Lift Down	Boom Tele Out	Boom Tele In	Jib Lift	Basket Level	Basket Rotate
R*/C**	R	C	R	R	C	C	C	R	R	R	C	C	C	C
R = Indicates Reversal is Activated														
C = Indicates Cutout is Activated														
*DOS (Drive Orientation System) Enabled														
** DOS Not Enabled, machine is driving straight without steering, and any other hydraulic function is active														
Note: If SkyGuard is enabled with the Soft Touch system, functions will cut out instead of reversing.														

4.11 LIFTING AND TIE DOWN

See Figure 4-6.

Lifting

1. Refer to the Serial Number Plate, refer to the Specifications section of this manual, or weigh the individual unit to find out the Gross Vehicle Weight.
2. Place the boom in the stowed position with the turntable locked.
3. Remove all loose items from the machine.
4. Attach lifting device and equipment only to the designated lifting points.
5. Properly adjust the rigging to prevent damage to the machine and so the machine remains level.

Tie Down

NOTICE

WHEN TRANSPORTING THE MACHINE, THE BOOM MUST BE FULLY LOWERED INTO THE BOOM REST.

1. Place the boom in the stowed position with the turntable locked.
2. Remove all loose items from the machine.
3. Secure the chassis and the platform using straps or chains of adequate strength and attached to the designated tie down points.

SECTION 4 - MACHINE OPERATION

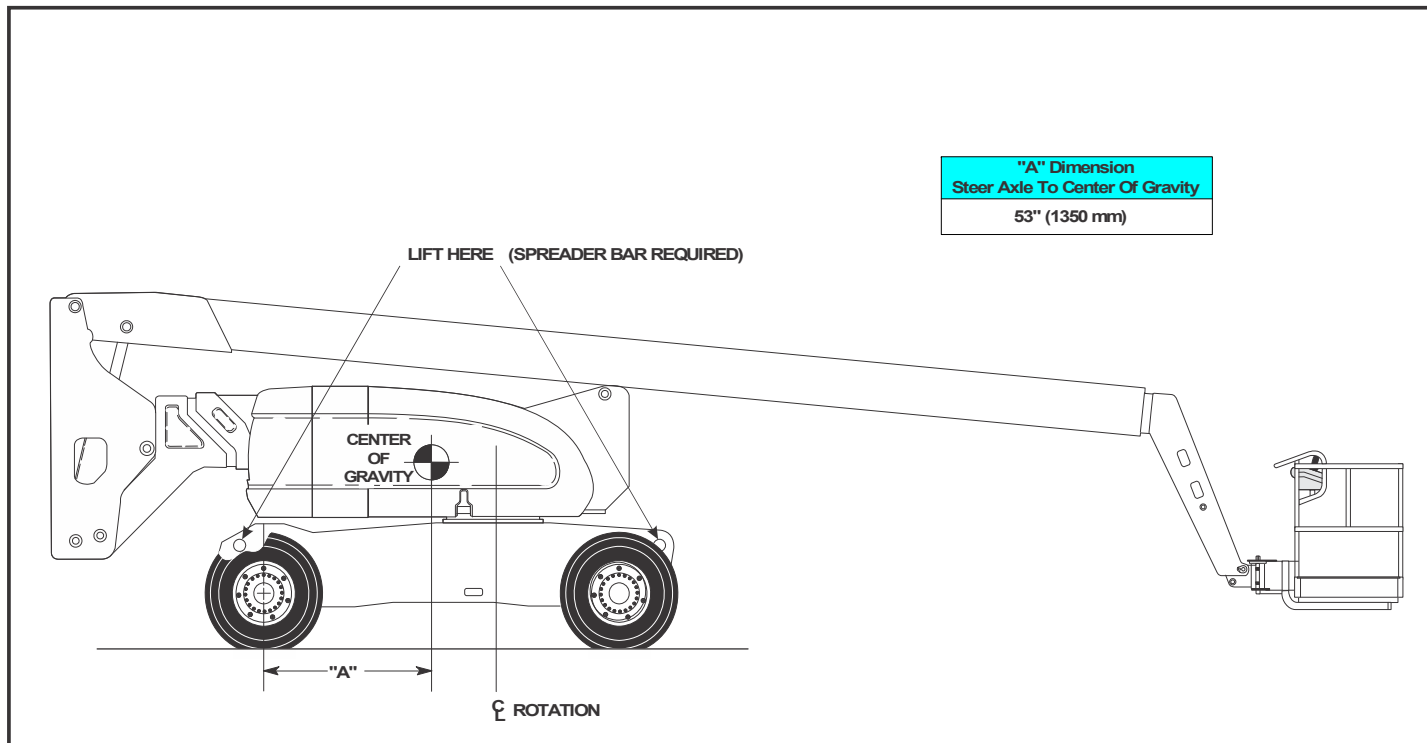

Figure 4-6. Lifting Chart

4.12 OSCILLATING AXLE LOCKOUT TEST (IF EQUIPPED)

NOTICE

LOCKOUT SYSTEM TEST MUST BE PERFORMED QUARTERLY, ANY TIME A SYSTEM COMPONENT IS REPLACED, OR WHEN IMPROPER SYSTEM OPERATION IS SUSPECTED.

Refer to Section 2.4, Oscillating Axle Lockout Test (If Equipped) for procedure.

4.13 TOWING

The machine is not equipped with a tow package. Refer to Section 5 for emergency towing procedures.

4.14 TOW BAR (IF EQUIPPED)

⚠ WARNING

RUNAWAY VEHICLE/MACHINE HAZARD. MACHINE HAS NO TOWING BRAKES. TOWING VEHICLE MUST BE ABLE TO CONTROL MACHINE AT ALL TIMES. ON-HIGHWAY TOWING NOT PERMITTED. FAILURE TO FOLLOW INSTRUCTIONS COULD CAUSE SERIOUS INJURY OR DEATH.

MAXIMUM TOWING SPEED 5 M.P.H. (8 K.M.H.)

MAXIMUM TOWING GRADE 25%.

Prior to towing the machine, complete the following:

⚠ CAUTION

DO NOT TOW MACHINE WITH ENGINE OPERATING OR DRIVE HUBS ENGAGED.

1. Retract, lower and position boom in travel position; lock turntable.
2. Lower tow bar and connect to towing vehicle
3. Disconnect drive hubs by inverting disconnect cap.

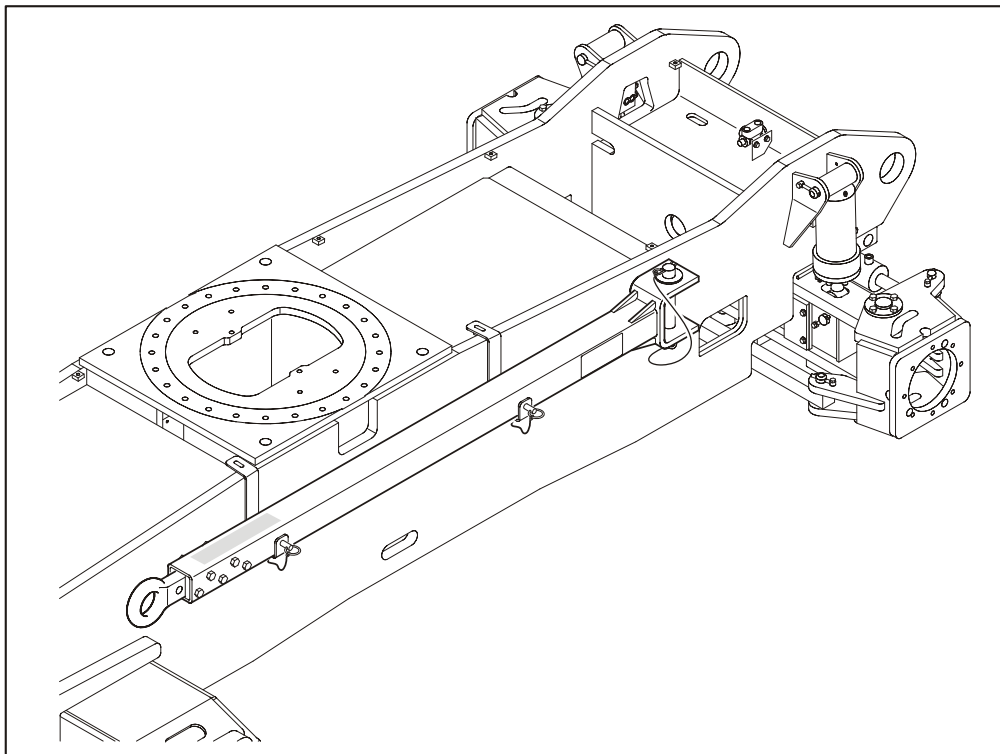

Figure 4-7. Tow Bar

4. Position steer/tow selector valve for towing; pull valve knob out for towing. The machine is now in the towing mode.

After towing the machine, complete the following:

1. Actuate steer/tow selector valve for steering; push valve knob in to the actuated position.
2. Reconnect drive hubs by inverting disconnect cap.
3. Disconnect tow bar from towing vehicle and place it in the stowed position as shown in Figure 4-7. The machine is now in the driving mode.

4.15 DUAL FUEL SYSTEM (GAS ENGINE ONLY)

Description

The dual fuel system enables the standard gasoline engine to run on either gasoline or LP gas. The system includes pressurized cylinders mounted on the frame, and the valves and switches needed to switch the fuel supply from gasoline to LP gas or from LP gas to gasoline.

A two position, Fuel Select switch at the platform control station supplies electrical power to open the gasoline shut-off solenoid and close the LP gas shut off solenoid when positioned to the Gasoline position. This switch also allows electrical power to open the LP gas shut-off solenoid and close the gasoline shut-off solenoid when positioned to the LP position.



⚠ CAUTION

IT IS POSSIBLE TO SWITCH FROM ONE FUEL SOURCE TO THE OTHER WITHOUT STOPPING THE ENGINE. EXTREME CARE MUST BE TAKEN AND THE FOLLOWING INSTRUCTIONS MUST BE FOLLOWED.

Changing From Gasoline to LP Gas

1. Start engine from Ground Control Console.

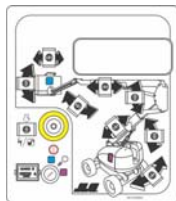

2. Open hand valve on LP gas supply tank by turning counter-clockwise.
3. While the engine is operating, place the two position LPG/Gasoline switch at the platform control station to the "LP" position.



Changing From LP Gas to Gasoline

1. With engine operating on LP under a no-load condition, position FUEL SELECT switch at Platform Control Station to GASOLINE position.
2. Close hand valve on LP gas supply tank by turning clockwise.



4.16 RE-SYNCHRONIZE UPRIGHT

Releveling Valve

A pull type control valve allows the operator to adjust the upright level cylinder if the upright is not 90° (vertical) relative to the chassis (Refer to Figure 2.9 and Figure 2.10). This valve is located in the tank compartment area.

Perform the following steps with the aid of an assistant:

1. Turn the key switch to the ground control position.
2. Start the engine.



3. Pull and hold the red relevel knob located next to the main control valve. Refer to Figure 4-8.
4. Raise the tower boom 6 feet (1.8 m).

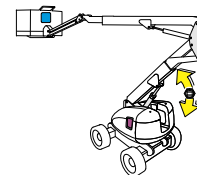

5. Release the red relevel knob.

6. Lower the tower boom fully and continue to hold down the switch to Tower Down for an additional 20 seconds.

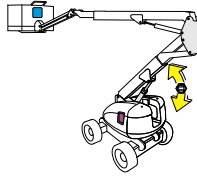

7. Repeat steps 3 thru 6 as necessary until the upright is 90° (vertical) relative to the chassis.

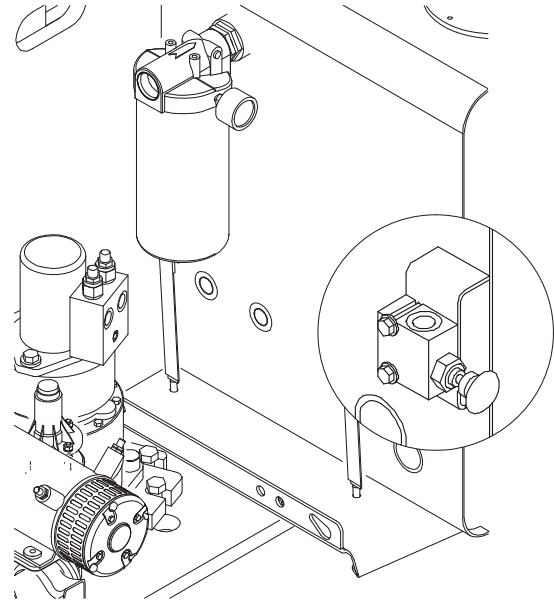

Figure 4-8. Releveling Valve

SECTION 4 - MACHINE OPERATION

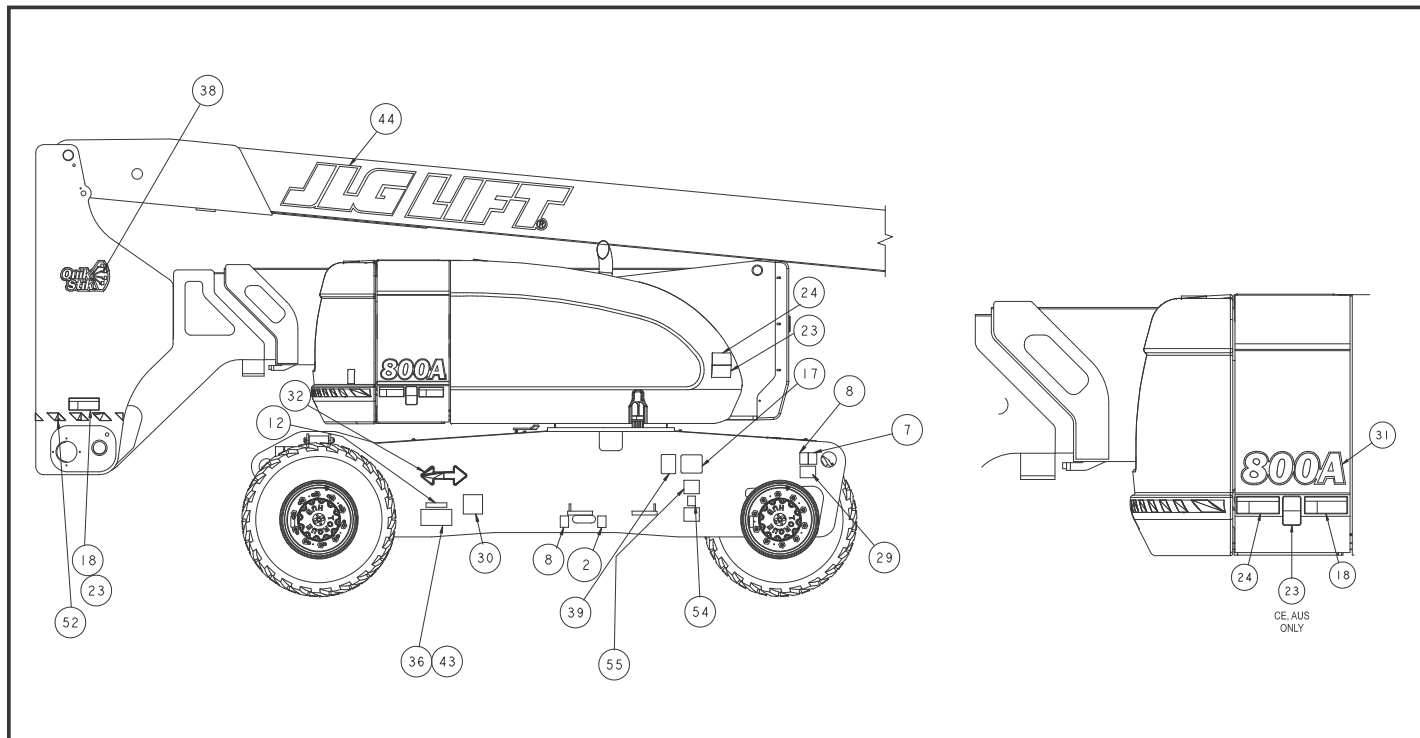

Figure 4-9. Decal Installation - Sheet 1 of 5

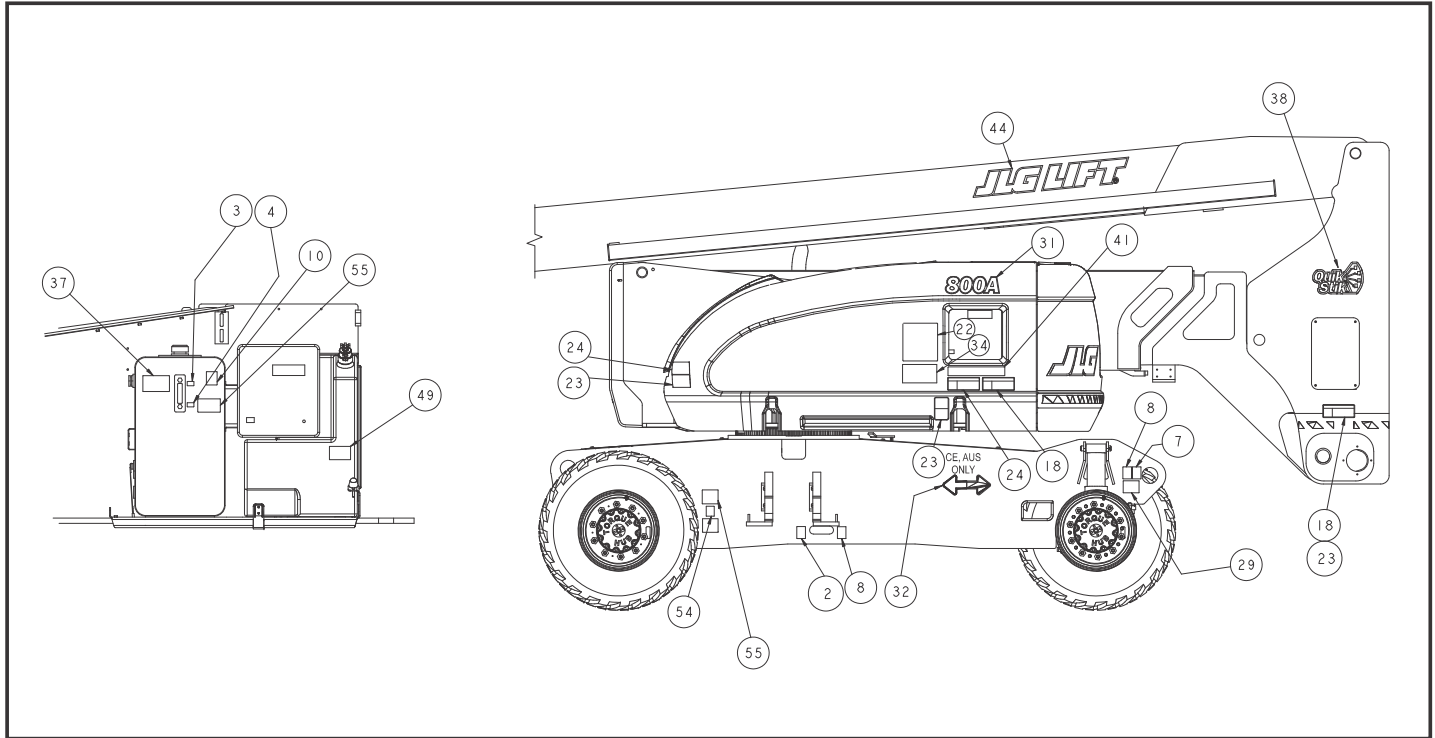

Figure 4-10. Decal Installation - Sheet 2 of 5

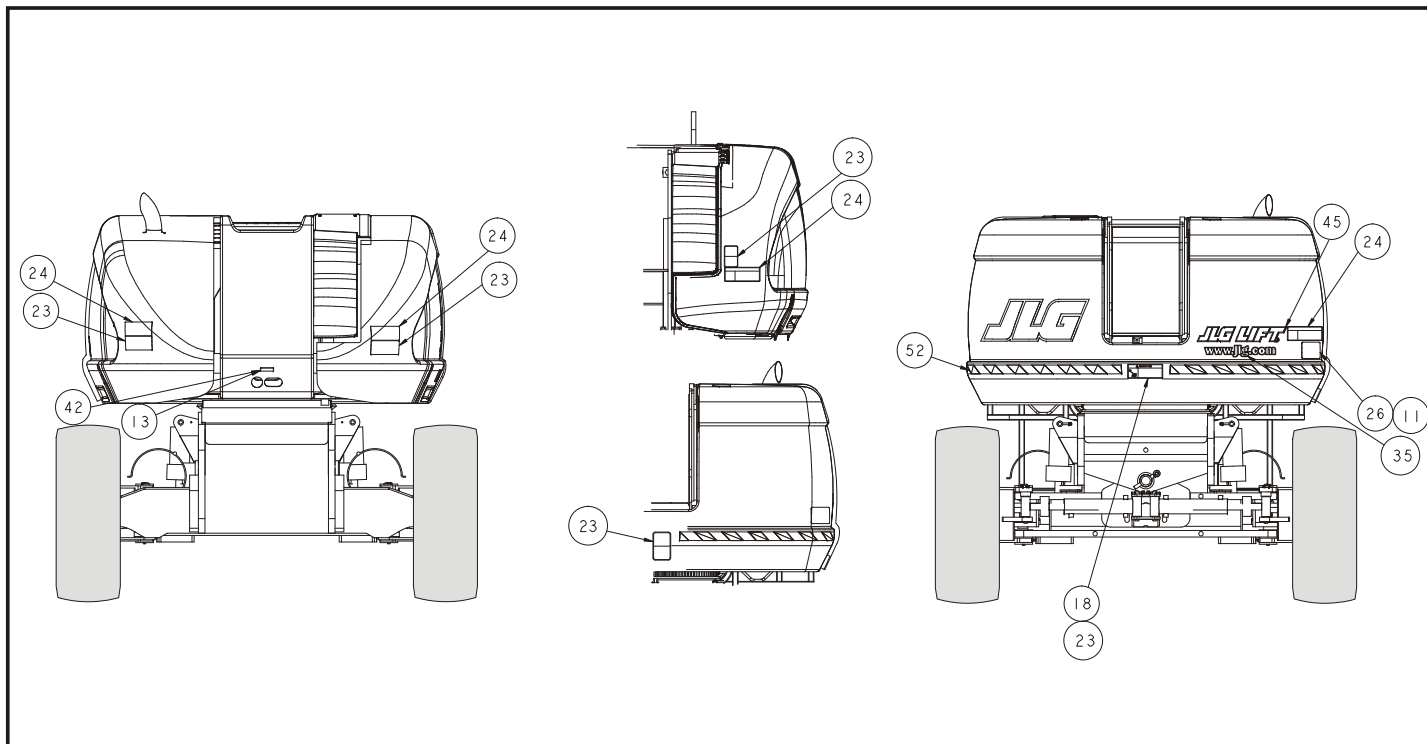

Figure 4-11. Decal Installation - Sheet 3 of 5

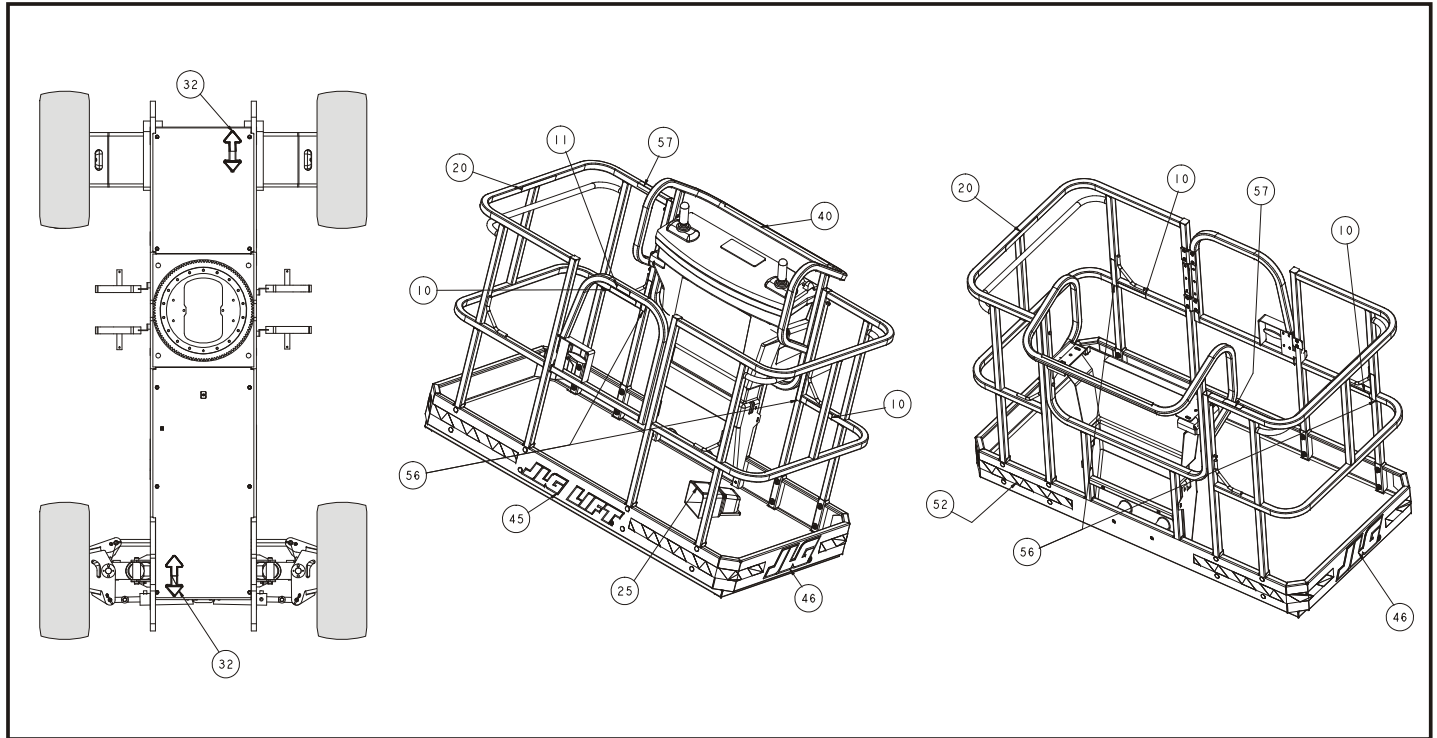

Figure 4-12. Decal Installation - Sheet 4 of 5

SECTION 4 - MACHINE OPERATION

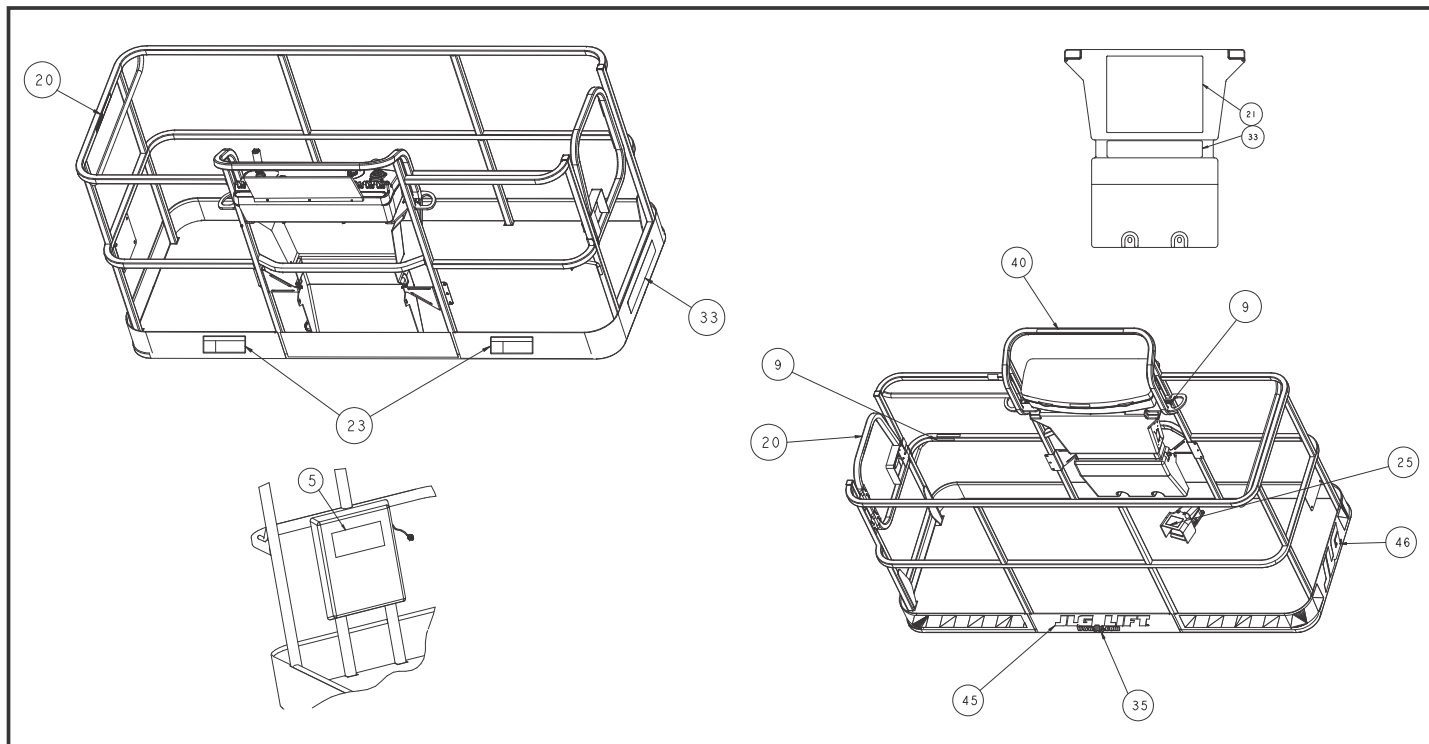

Figure 4-13. Decal Installation - Sheet 5 of 5

Table 4-1. Decal Legend - 800A

Item #	ANSI 0274460-B	Korean 0274464-B	Chinese 0274470-B	Spanish 0274466-B	Portuguese 0274468-B	French 0274472-B	CE/Aus 0274474-B	Japanese 0274462-B
1	--	--	--	--	--	--	--	--
2	1701499	1701499	1701499	1701499	1701499	1701499	1701499	1701499
3	--	--	--	--	--	--	--	--
4	--	--	--	--	--	--	--	--
5	1701509	1701509	1701509	1701509	1701509	1701509	1701509	1701509
6	--	--	--	--	1701529	--	--	--
7	1703811	1703811	1703811	1703811	1703811	1703811	1703811	1703811
8	1703814	1703814	1703814	1703814	1703814	1703814	1703814	1703814
9	1704277	1704277	1704277	1704277	1704277	1704277	1704277	1704277
10	1704412	1704412	1704412	1704412	1704412	1704412	1704412	1704412
11	--	--	--	--	--	--	1705980	--
12	--	--	--	--	--	1705514	--	--
13	--	--	--	--	--	--	--	--
14	--	--	--	--	--	--	--	--
15	1705337	1705339	1705342	--	--	--	--	--
16	--	--	--	--	--	--	--	--

SECTION 4 - MACHINE OPERATION**Table 4-1. Decal Legend - 800A**

Item #	ANSI 0274460-B	Korean 0274464-B	Chinese 0274470-B	Spanish 0274466-B	Portuguese 0274468-B	French 0274472-B	CE/Aus 0274474-B	Japanese 0274462-B
17	--	--	--	--	--	--	--	--
18	1703953	1703945	1703943	1703941	1705903	1703942	--	1703944
19	--	--	--	--	--	--	--	--
20	1702868	1705969	1705968	1704001	1705967	1704000	--	--
21	1703797	1703927	1703925	1703923	1705895	1703924	1705921	1703926
22	1705336	1705345	1705348	1705917	1705896	1705347	1705822	1705344
23	1703804	1703951	1703949	1703947	1705898	1703948	1701518	1703950
24	1703805	1703939	1703937	1703935	1705897	1703936	1705961	1703938
25	3252347	1703981	1703982	1703983	1705902	1703984	1705828	1703980
26	--	--	--	--	--	--	--	--
27	--	--	--	--	--	--	--	--
28	--	--	--	--	--	--	--	--
29	1703960	1703960	1703960	1703960	1703960	1703960	1703960	1703960
30	1702631	1702631	1702631	1702631	1702631	1702631	1702631	1702631
31	1703772	1703772	1703772	1703772	1703772	1703772	1703772	1703772
32	1701501	1701501	1701501	1701501	1701501	1701501	1701501	1701501
33	1001121800	1001122200	1001121809	1001121804	1001121806	1001121802	1705978	1001121807

Table 4-1. Decal Legend - 800A

Item #	ANSI 0274460-B	Korean 0274464-B	Chinese 0274470-B	Spanish 0274466-B	Portuguese 0274468-B	French 0274472-B	CE/Aus 0274474-B	Japanese 0274462-B
34	1001121813	1001122201	1001121822	1001121817	1001121819	1001121815	1705978	1001121820
35	--	--	--	--	--	--	--	--
36	--	1706948	--	--	--	1706948	--	--
37	1702265	1703987	1703988	1703989	1706439	1703990	1705977	1703986
38	1703959	1703959	1703959	1703959	1703959	1703959	1703959	1703959
39	1001131269	--	--	--	--	1001131269	--	--
40	1001108495	1001108495	1001108495	1001108495	1001108495	1001108495	--	1001108495
41	1706941	1706941	1706941	1706941	1706941	1706941	--	1706941
42	--	--	--	--	--	--	--	--
43	--	--	--	--	--	--	--	--
44	--	--	--	--	--	--	--	--
45	--	--	--	--	--	--	--	--
46	--	--	--	--	--	--	--	--
47	--	--	--	--	--	--	--	--
48	--	--	--	--	--	--	--	--
49	--	--	--	--	--	--	--	--
50	--	--	--	--	--	--	--	--

SECTION 4 - MACHINE OPERATION

Table 4-1. Decal Legend - 800A

Item #	ANSI 0274460-B	Korean 0274464-B	Chinese 0274470-B	Spanish 0274466-B	Portuguese 0274468-B	French 0274472-B	CE/Aus 0274474-B	Japanese 0274462-B
51	--	--	--	--	--	--	--	--
52	--	--	--	--	--	--	--	--
53	--	--	--	--	--	--	--	--
54	--	--	--	--	--	--	--	--
55	--	--	--	--	--	--	--	--
56	1705351	1705427	1705430	1705910	1705905	1705429	--	1705426

Table 4-2. Decal Legend - 800AJ

Item #	ANSI 0274461-B	Korean 0274465-B	Chinese 0274471-B	Spanish 0274467-B	Portuguese 0274469-B	French 0274473-B	CE/Aus 0274475-B	Japanese 0274463-B
1	--	--	--	--	--	--	--	--
2	1701499	1701499	1701499	1701499	1701499	1701499	1701499	1701499
3	--	--	--	--	--	--	--	--
4	--	--	--	--	--	--	--	--
5	1701509	1701509	1701509	1701509	1701509	1701509	1701509	1701509
6	--	--	--	--	--	--	--	--
7	1703811	1703811	1703811	1703811	1703811	1703811	1703811	1703811
8	1703814	1703814	1703814	1703814	1703814	1703814	1703814	1703814
9	1704277	1704277	1704277	1704277	1704277	1704277	1704277	1704277
10	1704412	1704412	1704412	1704412	1704412	1704412	1704412	1704412
11	--	--	--	--	--	--	1705980	--
12	--	--	--	--	--	1705514	--	--
13	--	--	--	--	--	--	--	--
14	--	--	--	--	--	--	--	--
15	1705337	1705339	1705342	--	--	--	--	--
16	--	--	--	--	--	--	--	--
17	--	--	--	--	--	--	--	--

SECTION 4 - MACHINE OPERATION

Table 4-2. Decal Legend - 800AJ

Item #	ANSI 0274461-B	Korean 0274465-B	Chinese 0274471-B	Spanish 0274467-B	Portuguese 0274469-B	French 0274473-B	CE/Aus 0274475-B	Japanese 0274463-B
18	1703953	1703945	1703943	1703941	1705903	1703942	--	1703944
19	--	--	--	--	--	--	--	--
20	1702868	1705969	1705968	1704001	1705967	1704000	--	--
21	1703797	1703927	1703925	1703923	1705895	1703924	1705921	1703926
22	1705336	1705345	1705348	1705917	1705896	1705347	1705822	1705344
23	1703804	1703951	1703949	1703947	1705898	1703948	1701518	1703950
24	1703805	1703939	1703937	1703935	1705897	1703936	1705961	1703938
25	3252347	1703981	1703982	1703983	1705902	1703984	1705828	1703980
26	3241813	--	--	--	--	--	--	3251813
27	--	--	--	--	--	--	--	--
28	--	--	--	--	--	--	--	--
29	1703960	1703960	1703960	1703960	1703960	1703960	1703960	1703960
30	1702631	1702631	1702631	1702631	1702631	1702631	1702631	1702631
31	1703773	1703773	1703773	1703773	1703773	1703773	1703773	1703773
32	1701501	1701501	1701501	1701501	1701501	1701501	1701501	1701501
33	1001121801	1001121918	1001121919	1001121805	1001121656	1001121803	1705978	1001121808
34	1001121814	1001121921	1001121922	1001121818	1001121655	1001121816	1705978	1001121821
35	--	--	--	--	--	--	--	--

Table 4-2. Decal Legend - 800AJ

Item #	ANSI 0274461-B	Korean 0274465-B	Chinese 0274471-B	Spanish 0274467-B	Portuguese 0274469-B	French 0274473-B	CE/Aus 0274475-B	Japanese 0274463-B
36	--	--	--	--	--	1706948	--	--
37	1001096141	1703987	1703990	1703989	1706439	1703990	1705977	1703986
38	1703959	1703959	1703959	1703959	1703959	1703959	1703959	1703959
39	1001131269	--	--	--	--	--	--	--
40	1001108495	1001108495	1001108495	1001108495	1001108495	1001108495	--	1001108495
41	1706941	1706941	1706941	1001095809	1706941	1706941	--	1706941
42	--	--	--	--	--	--	--	--
43	--	--	--	--	--	--	--	--
44	--	--	--	--	--	--	--	--
45	--	--	--	--	--	--	--	--
46	--	--	--	--	--	--	--	--
47	--	--	--	--	--	--	--	--
48	--	--	--	--	--	--	--	--
49	--	--	--	--	--	--	--	--
50	--	--	--	--	--	--	--	--
51	--	--	--	--	--	--	--	--
52	--	--	--	--	--	--	--	--
53	--	--	--	--	--	--	--	--

SECTION 4 - MACHINE OPERATION

Table 4-2. Decal Legend - 800AJ

Item #	ANSI 0274461-B	Korean 0274465-B	Chinese 0274471-B	Spanish 0274467-B	Portuguese 0274469-B	French 0274473-B	CE/Aus 0274475-B	Japanese 0274463-B
54	--	--	--	--	--	--	--	--
55	--	--	--	--	--	--	--	--
56	1705351	1705427	1705430	1705910	1705905	1705429	--	1705426

SECTION 5. EMERGENCY PROCEDURES

5.1 GENERAL

This section explains the steps to be taken in case of an emergency situation while operating.

5.2 INCIDENT NOTIFICATION

JLG Industries, Inc. must be notified immediately of any incident involving a JLG product. Even if no injury or property damage is evident, the factory should be contacted by telephone and provided with all necessary details.

- USA: 877-JLG-SAFE (554-7233)
- EUROPE: (32) 0 89 84 82 20
- AUSTRALIA: (61) 2 65 811111
- E-mail: ProductSafety@JLG.com

Failure to notify the manufacturer of an incident involving a JLG Industries product within 48 hours of such an occurrence may void any warranty consideration on that particular machine.

NOTICE

FOLLOWING ANY ACCIDENT, THOROUGHLY INSPECT THE MACHINE AND TEST ALL FUNCTIONS FIRST FROM THE GROUND CONTROLS, THEN FROM THE PLATFORM CONTROLS. DO NOT LIFT ABOVE 3 M (10 FT.) UNTIL YOU ARE SURE THAT ALL DAMAGE HAS BEEN REPAIRED, IF REQUIRED, AND THAT ALL CONTROLS ARE OPERATING CORRECTLY.

5.3 EMERGENCY OPERATION

Operator Unable to Control Machine

IF THE PLATFORM OPERATOR IS PINNED, TRAPPED OR UNABLE TO OPERATE OR CONTROL MACHINE:

1. Other personnel should operate the machine from ground controls only as required.
2. Other qualified personnel on the platform may use the platform controls. DO NOT CONTINUE OPERATION IF CONTROLS DO NOT FUNCTION PROPERLY.
3. Cranes, forklift trucks or other equipment can be used to remove platform occupants and stabilize motion of the machine.

Platform or Boom Caught Overhead

If the platform or boom becomes jammed or snagged in overhead structures or equipment, do the following:

1. Shut off the machine.
2. Rescue all people in the platform before freeing the machine. Personnel must be out of the platform before operating any controls on the machine.
3. Use cranes, forklifts, or other equipment to stabilize motion of the machine to prevent a tip over as required.
4. From the ground controls, use the Auxiliary Power System (if equipped) to carefully free the platform or boom from the object.
5. Once clear, restart the machine and return the platform to a safe position.
6. Inspect the machine for damage. If the machine is damaged or does not operate properly, turn off the machine immediately. Report the problem to the proper maintenance personnel. Do not operate the machine until it is declared safe for operation.

5.4 EMERGENCY TOWING PROCEDURES

Towing this machine is prohibited, unless properly equipped. However, provisions for moving the machine have been incorporated. For specific procedures, refer to Section 4.

5.5 MACHINE SAFETY SYSTEM OVERRIDE (MSSO)(CE ONLY)

The Machine Safety System Override (MSSO) is only to be used to retrieve an operator that is pinned, trapped, or unable to operate the machine and function controls are locked out from the platform due to a platform overload situation.



NOTE: *If the MSSO functionality is used, the fault indicator will flash and a fault code is set in the JLG Control System which must be reset by a qualified JLG Service Technician.*

NOTE: *No functional checks of the MSSO system are necessary. The JLG Control system will set a Diagnostic Trouble Code if the control switch is faulty.*

To operate the MSSO:

1. From the ground control console, place the Platform/ Ground Select switch in the Ground position.
2. Pull out the Power/Emergency Stop control.
3. Start the engine.
4. Press and hold the MSSO switch and the control switch for the desired function.

SECTION 5 - EMERGENCY PROCEDURES



NOTES:

SECTION 6. ACCESSORIES

Table 6-1. Available Accessories

Accessory	Market						
	ANSI (USA Only)	ANSI	CSA	CE	AUS	Japan	China
Fall Arrest Platform (36" x 96")	√	√	√	√			√
Fall Arrest Platform (36" x 72")	√	√	√				√
Pipe Racks	√	√	√		√		√
SkyAir™	√	√	√		√		√
SkyCutter™	√	√	√				√
SkyGlazier™	√	√	√		√		√
SkyPower™	√	√	√	√	√	√	√
SkyWelder™	√	√	√	√	√	√	√
Soft Touch	√	√	√	√	√	√	√
Bolt-On External Fall Arrest (36" x 96")	√	√	√			√	√
Bolt-On External Fall Arrest (36" x 72")	√	√	√			√	√

SECTION 6 - ACCESSORIES

Table 6-2. Options/Accessories Relationship Table

ACCESSORY	REQUIRED ITEM	COMPATIBLE WITH (Note 1)	INCOMPATIBLE WITH	INTERCHANGABLE WITH (Note 2)
Pipe Racks		SkyPower™	Platform MMR**, Platform MTR*, Soft Touch	SkyCutter, SkyGlazier, SkyWelder
SkyAir™	SkyPower™	SkyCutter™, SkyGlazier™, SkyWelder™		
SkyCutter™	SkyPower™	SkyWelder™	4' Platform, Pipe Racks, Platform MTR*, Soft Touch	SkyGlazier™
SkyGlazier™		SkyPower™	4' Platform, Pipe Racks, Platform MTR*, Soft Touch	SkyCutter™, SkyWelder™
SkyPower™		SkyCutter™, SkyGlazier™, SkyWelder™		
SkyWelder™	SkyPower™	SkyCutter™	4' Platform, Pipe Racks, Platform MTR*, Soft Touch	SkyGlazier™
Soft Touch			Pipe Racks, SkyCutter™, SkyGlazier™, SkyWelder™	

Note 1: Any non-"Sky" accessory not listed under "INCOMPATIBLE WITH" is assumed to be compatible.

Note 2: Can be used on same unit but not simultaneously.

* Platform MTR = Platform Mesh to Top Rail; ** Platform MMR = Platform Mesh to Mid Rail

4150459 M

6.1 FALL ARREST PLATFORM

NOTE: See the JLG External Fall Arrest System manual (PN 3128935) for more detailed information.

The external fall arrest system is designed to provide a lanyard attach point while allowing the operator to access areas outside the platform. Exit/enter the platform through the gate area only. The system is designed for use by one person.

Personnel must use fall protection at all times. A full body harness is required with lanyard not to exceed 6 ft (1.8 m) in length, that limits the maximum arrest force to 900 lbs (408 kg) for the trans-faster type and 1350 lbs (612 kg) for the shuttle type fall arrest system.

Safety Precautions

⚠ WARNING

DO NOT OPERATE ANY MACHINE FUNCTIONS WHILE OUTSIDE THE PLATFORM. USE CAUTION WHEN ENTERING/EXITING THE PLATFORM AT ELEVATION.

6.2 PIPE RACKS

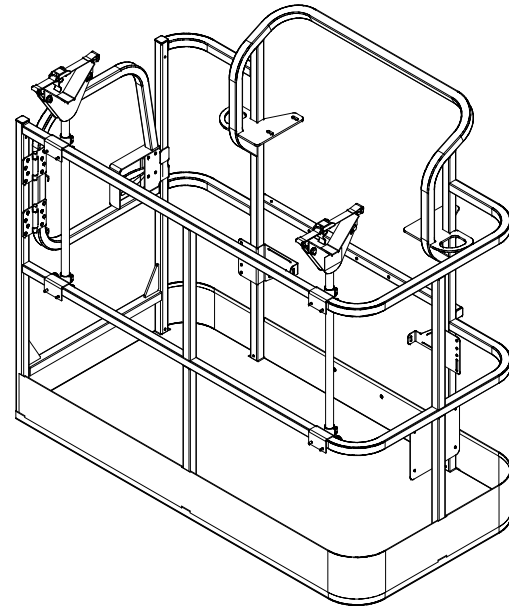

Pipe Racks provide a way to store pipe or conduit inside the platform in order to prevent rail damage and optimize platform utility. This accessory consists of two racks with adjustable straps to secure the load in place.

Capacity Specifications (Australia Only)

Max. Capacity in Racks	Max. Platform Capacity (With Max. Weight in Racks)
80 kg	184 kg
Max. Length of Material in Racks: 6.0 m Min. Length of Material in Racks: 2.4 m	

Safety Precautions

WARNING

REDUCE PLATFORM CAPACITY BY 100 LBS (45.5 KG) WHEN INSTALLED.

WARNING

WEIGHT IN RACKS PLUS WEIGHT IN PLATFORM MUST NOT EXCEED RATED CAPACITY.

NOTICE

THE MAXIMUM LOAD IN THE RACKS IS 180 LBS (80 KG) EVENLY DISTRIBUTED BETWEEN THE TWO RACKS.

NOTICE

THE MAXIMUM LENGTH OF MATERIAL IN RACKS IS 20 FT (6.1 M).

- Ensure no personnel are beneath the platform.
- Do not exit platform over rails or stand on rails.
- Do not drive machine without material secured
- Return racks to the stowed position when not in use.
- Use this option only on approved models.

Preparation and Inspection

- Ensure racks are secured to the platform rails.
- Replace torn or frayed tie-down straps.

Operation

1. To prepare racks for loading, remove locking pins, rotate each rack 90 degrees from stowed to working position, then secure with locking pins.
2. Loosen and remove tie-down straps. Place material on racks with weight evenly distributed between both racks.
3. Route the tie-down straps at each end across loaded material and tighten.
4. To remove material, loosen and remove tie-down straps, then carefully remove material from racks.

NOTE: *Reinstall tie-down straps across any remaining material before continuing machine operations.*

6.3 SKYAIR™

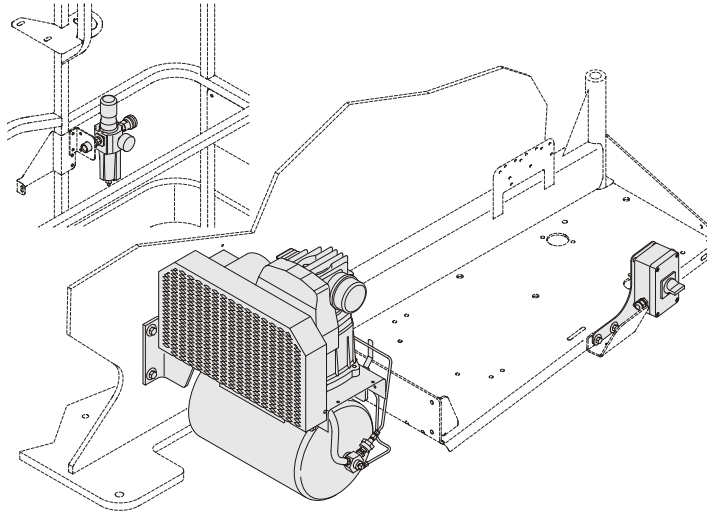

SkyAir™ supplies compressed air to the platform. A filter/regulator located in the platform controls air pressure. The on/off switch is located in the engine compartment. This accessory receives power from the SkyPower™ system.

Compressor Specifications

- Single stage with dual control
- CFM displacement: 9.3
- Motor: 230 V, 2 hp, 3-phase

Accessory Ratings

CONTROL MODE	VOLUME
Automatic Start-Stop Control	100 - 130 psi
Constant Run Control	105 - 120 psi

Safety Precautions

⚠ WARNING
DO NOT OVERLOAD PLATFORM.

- Ensure no personnel are beneath platform.
- This factory-installed option is available only on specified models.
- Keep lanyard attached at all times.

Preparation and Inspection

- Ensure compressor and hoses are secure.
- Check condition of belt and wiring.

Operation

Start the engine, turn on the generator, then turn on the air compressor.

See the J-Air Manual (PN 3128970) for more information.

6.4 SKYCUTTER™

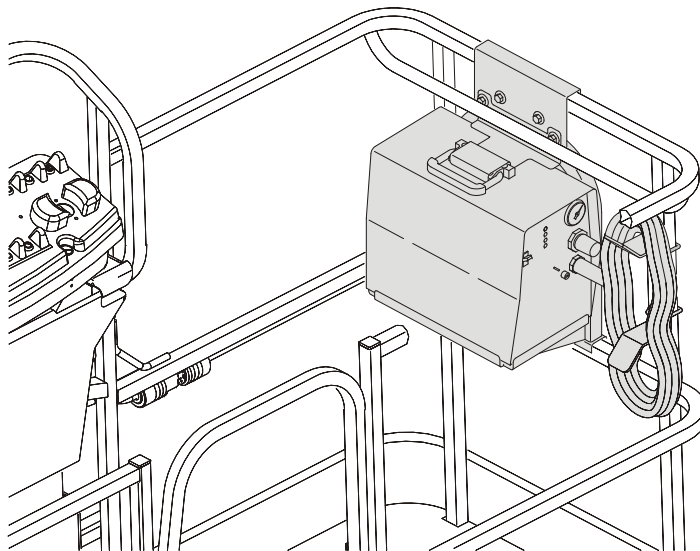

SkyCutter™ is capable of cutting up to a thickness of 3/8" metal. It can produce 27 A at 92 VDC at 35% duty cycle or 14 A at 92 VDC at 60% duty cycle. It receives power from the SkyPower™ system.

Accessory Ratings

Spec.	Rated Output	Amperes Input @ Rated Output, 60 Hz, 1-Phase	kVa/kW	Plasma Gas	Plasma Gas Flow/ Pressure	Rated Cutting Capacity @ 101PM	Max. OCV
120 Volts ±10% (20 A)	27 A @ 91 VDC @ 20% Duty Cycle	28.8 max; 0.30*	3.4 kVa 3.2 kW	Air or Nitrogen Only @ 90 - 120 psi (621 - 827 kPa)	4.5 cfm (129 L/Min) @ 60 psi (414 kPa)	3/8 in (10 mm)	400 VDC
120 Volts ±10% (15 A)	20 A @ 88 VDC @ 35% Duty Cycle	20.6 max; 0.30*	2.5 kVa 2.3 kW				
240 Volts ±10% (27 A)	27 A @ 91 VDC @ 35% Duty Cycle	13.9 max; 0.13*	3.3 kVa 3.0 kW				
*While idling.							

Generator Output

Engine Speed of 1800 rpm +/- 10%.

ANSI Specifications:

- 3-phase: 240 V, 60 Hz, 7.5 kW
- 1-phase: 240 V/120 V, 60 Hz, 6 kW

Safety Precautions



WARNING

DO NOT OVERLOAD PLATFORM.



WARNING

DE-RATE THE PLATFORM BY 70 LBS (32 KG) WHEN PLASMA CUTTER IS IN PLATFORM.

- Check for cracked welds and damage to plasma supports.
- Check for secure installation of cutter and bracket.

SECTION 6 - ACCESSORIES

- Ensure no personnel are beneath platform.
- Do not exit platform over rails or stand on rails.
- Use this option only on approved models.
- Keep lanyard attached at all times.
- Use correct cutting settings.
- Do not use electrical cords without ground.
- Do not use electrical tools in water.
- Do not cut platform, or ground through the platform.
- Wear proper cutting apparel.
- Do not drive machine while connected to external air/gas sources.

Preparation and Inspection

- Connect ground clamp to metal being cut.
- Ensure there is a good ground connection.

Operation

Start the engine, turn on the generator, then turn on the plasma cutter.

See the Miller Plasma Cutter Owner's Manual (PN 3128420) for more information.

6.5 SKYGLAZIER™

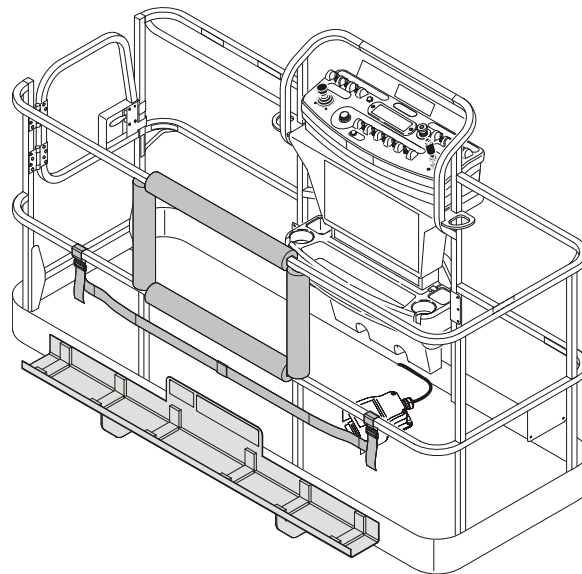

SkyGlazier™ allows glaziers to position panels efficiently. The glazier package consists of a tray that attaches the bottom of the platform. The panel rests on the tray and against top-rail of the platform, which is padded to prevent damage. SkyGlazier™ includes a strap to secure the panel to the platform rail.

Capacity Specifications

Capacity Zone *	Max. Tray Capacity	Max. Platform Capacity (With Max. Weight in Tray)
500 lbs (227 kg)	150 lbs (68 kg)	250 lbs (113 kg)
550 lbs (250 kg)	150 lbs (68 kg)	250 lbs (113 kg)
600 lbs (272 kg)	150 lbs (68 kg)	250 lbs (113 kg)
750 lbs (340 kg)	150 lbs (68 kg)	440 lbs (200 kg)
1000 lbs (454 kg)	250 lbs (113 kg)	500 lbs (227 kg)
* Refer to the capacity decals installed on the machine for capacity zone information.		
Required Platform Type: Side-Entry		
Max. Dimensions of Panel: 32 sq.ft. (3 sq.m.)		

Safety Precautions

WARNING

ENSURE PANEL IS SECURED WITH STRAP.

WARNING

DO NOT OVERLOAD TRAY OR PLATFORM. TOTAL MACHINE CAPACITY IS REDUCED WHEN TRAY IS INSTALLED.

WARNING

WITH SKYGLAZIER™ INSTALLED, THE ORIGINAL PLATFORM CAPACITY RATINGS ARE REDUCED AS SPECIFIED IN THE CAPACITY SPECIFICATIONS TABLE. DO NOT EXCEED NEW PLATFORM CAPACITY RATINGS. REFER TO CAPACITY DECAL LOCATED ON TRAY.

WARNING

AN INCREASE OF THE AREA EXPOSED TO THE WIND WILL DECREASE STABILITY. LIMIT PANEL AREA TO 32 SQ.FT. (3 SQ.M).

- Ensure no personnel are beneath platform.
- Do not exit platform over rails or stand on rails.
- Remove tray when not in use.
- Use this option only on approved models.

Preparation and Inspection

- Check for cracked welds and damage to tray.
- Ensure tray is properly secured to platform.
- Ensure strap is not torn or frayed.

Operation

1. Load SkyGlazier™ tray with panel.
2. Route the adjustable strap around the panel and tighten until secure.
3. Position panel to its desired location.

6.6 SKYPOWER™

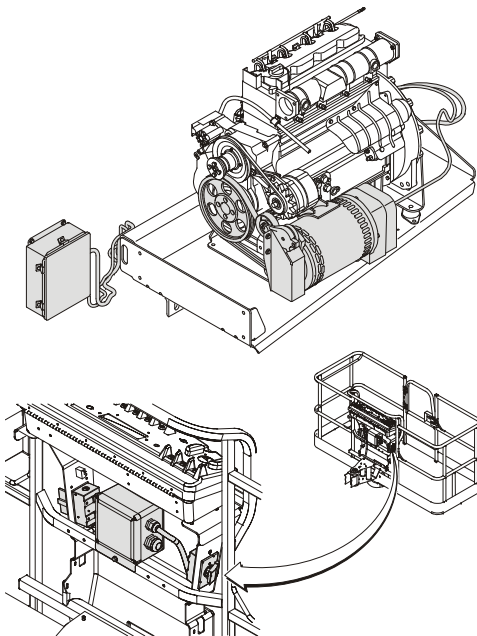

The SkyPower™ system supplies AC power to the platform through an AC receptacle to run tools, lights, cutting, and welding equipment.

All power regulation components are located in a watertight box connected by cable to the generator. The generator supplies power when running at the specified speed with the power switch on (switch is located on platform). A three-pole, 30 Amp circuit breaker protects the generator from overload.

Generator Output

ANSI Specifications:

- 3-phase: 240 V, 60 Hz, 7.5 kW
- 1-phase: 240 V/120 V, 60 Hz, 6 kW

CE Specifications:

- 3-phase: 240 V, 7.5 kW, 18.3 A, 1.0-pf
- 1-phase: 240 V, 6.0 kW, 26 A, 1.0-pf
- 1-phase: 120 V, 6.0 kW, 50 A, 1.0-pf

Peak:

- 3-phase: 8.5 kW
- 1-phase: 6.0 kW

Accessory Ratings

- 3000 rpm (50 Hz)
- 3600 rpm (60 Hz)

Safety Precautions



DO NOT OVERLOAD PLATFORM.

- Ensure no personnel are beneath platform.
- This factory-installed option is available only on specified models.
- Keep lanyard attached at all times.
- Do not use electrical tools in water.
- Use correct voltage for tool being used.
- Do not overload circuit.

Preparation and Inspection

- Ensure generator is secure.
- Check condition of belt and wiring.

Operation

Start the engine, then turn on the generator.

See the Miller Generator Technical Manual (PN 3121677) for more information.

6.7 SKYWELDER™

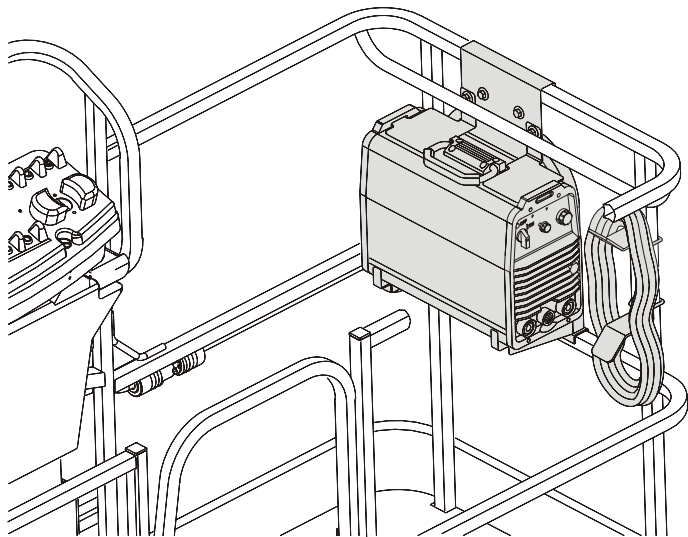

SkyWelder™ is capable of TIG and Stick welding, producing 200 Amps at 100% duty cycle or 250 Amps at 50% duty cycle. This accessory receives power from the SkyPower™ system.

Generator Output

Engine Speed of 1800 rpm +/- 10%.

ANSI Specifications:

- 3-phase: 240 V, 60 Hz, 7.5 kW
- 1-phase: 240 V/120 V, 60 Hz, 6 kW

CE Specifications:

- 3-phase: 400 V, 50 Hz, 7.5 kW
- 1-phase: 220 V, 50 Hz, 6 kW

Welding Accessories

- 12 ft welding leads with clamp and stinger (stored in the platform)
- Fire extinguisher

Accessory Ratings

Welding Mode	Input Power	Rated Output	Welding Amperage Range	Maximum Open Circuit Voltage	Amps Input At Rated Load Output (50/60 Hz)				
					230 V	460 V	575 V	kVa	kW
Stick (SMAW) TIG (GTAW)	3-phase	280 Amp at 31.2 V, 35% Duty Cycle	5-250 A	79VDC	32	17	13	15.7	10
		200 Amp at 28 V, 100% Duty Cycle			20	11	8	10.3	6.4
	1-phase	200 Amp at 28 V, 50% Duty Cycle	5-200 A	79VDC	35	-----	-----	9.8	6.5
		150 Amp at 28 V, 100% Duty Cycle			34	-----	-----	6.9	4.4

Safety Precautions

WARNING

DO NOT OVERLOAD PLATFORM.

WARNING

DE-RATE THE PLATFORM BY 70 LBS (32 KG) WHEN WELDER IS IN THE PLATFORM.

- Check for cracked welds and damage to welder supports.
- Check for proper and secure installation of welder and bracket.
- Ensure no personnel are beneath platform.
- Do not exit platform over rails or stand on rails.
- Use this option only on approved models.
- Keep lanyard attached at all times.
- Ensure correct polarity of leads.
- Wear proper welding apparel.

SECTION 6 - ACCESSORIES

- Use correct rod size and current settings.
- Do not use electrical cords without ground.
- Do not use electrical tools in water.
- Do not weld to the platform.
- Do not ground through the platform.
- Do not use a high frequency arc starter with TIG welder.

Preparation and Inspection

- Connect ground clamp to metal being welded.
- Ensure there is a good ground connection and observe proper polarity.

Operation

Start the engine, turn on the generator, then turn on the welder.

See the Miller Welder Owner's Manual (PN 3128957) for more information.

6.8 SOFT TOUCH

A padding kit is mounted to the platform rails and to a frame suspended below the platform. Limit switches deactivate platform functions when the padded framework contacts an adjacent structure. A button on the platform console allows override of the system.

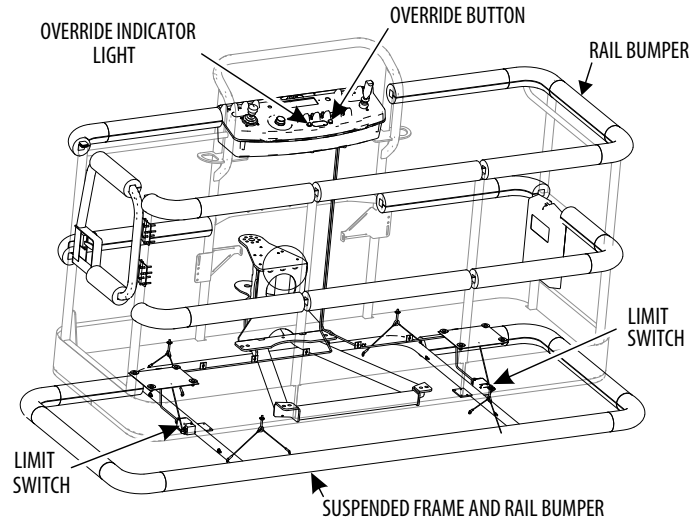

6.9 BOLT-ON EXTERNAL FALL ARREST

The bolt-on external fall arrest system is designed to provide a lanyard attach point while allowing the operator to access areas outside the platform. Exit/Enter the platform through the gate area only. The system is designed for use by one person.

Personnel must use fall protection at all times. A full body harness is required with lanyard not to exceed 6 ft. (1.8 M) in length, that limits the maximum arrest force to 900 lbs. (408 kg).

External Fall Arrest System capacity is 310 lb (140 kg) - one (1) person maximum.

Do not move platform during use of the external fall arrest system.

WARNING

DO NOT OPERATE ANY MACHINE FUNCTIONS WHILE OUTSIDE OF PLATFORM. BE CAREFUL WHEN ENTERING/EXITING THE PLATFORM AT ELEVATION.

WARNING

IF THE EXTERNAL FALL ARREST SYSTEM IS USED TO ARREST A FALL OR IS OTHERWISE DAMAGED, THE ENTIRE SYSTEM MUST BE REPLACED AND THE PLATFORM FULLY INSPECTED BEFORE RETURNING TO SERVICE. REFER TO THE SERVICE MANUAL FOR REMOVAL AND INSTALLATION PROCEDURES.

NOTICE

THE EXTERNAL FALL ARREST SYSTEM REQUIRES AN ANNUAL INSPECTION AND CERTIFICATION. THE ANNUAL INSPECTION AND CERTIFICATION MUST BE PERFORMED BY A QUALIFIED PERSON OTHER THAN THE USER.

Inspection Before Use

The external fall arrest system must be inspected before each use of the aerial work platform. Replace components if there are any signs of wear or damage.

Before each use, perform a visual inspection of the following components:

- Cable: Inspect cable for proper tension, broken strands, kinks, or any signs of corrosion.

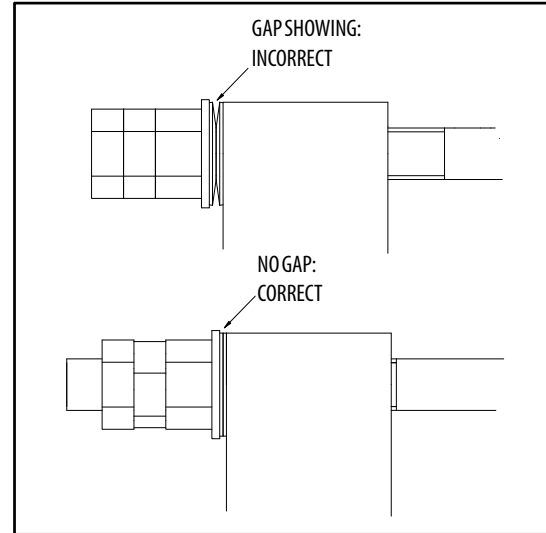

Figure 6-1. Bolt-On External Fall Arrest Cable Tension

- Fittings & Brackets: Ensure all fittings are tight and there are no signs of fractures. Inspect brackets for any damage.

- Attachment Ring: No cracks or signs of wear are acceptable. Any signs of corrosion requires replacement.
- Attaching Hardware: Inspect all attaching hardware to ensure there are no missing components and hardware is properly tightened.
- Platform Rails: No visible damage is acceptable.

SECTION 6 - ACCESSORIES

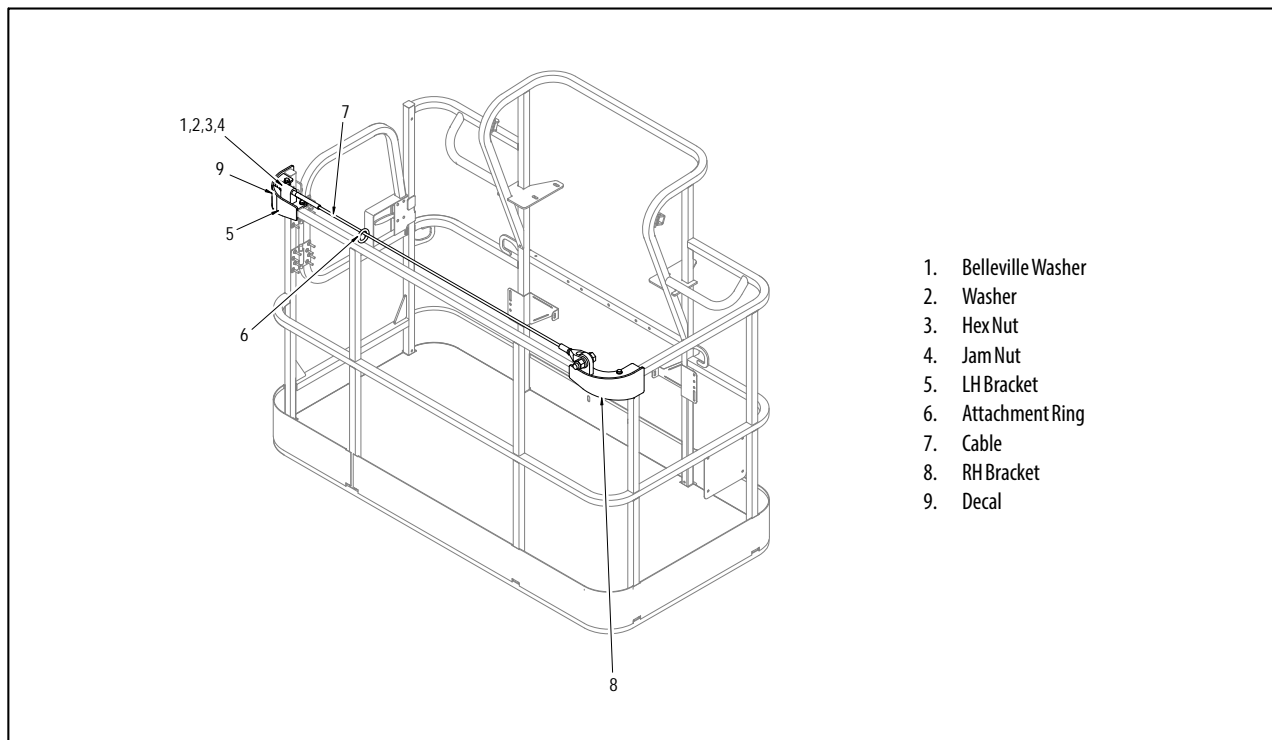

Figure 6-2. Bolt-On External Fall Arrest System

SECTION 7. GENERAL SPECIFICATIONS & OPERATOR MAINTENANCE

7.1 INTRODUCTION

This section of the manual provides additional necessary information to the operator for proper operation and maintenance of this machine.

The maintenance portion of this section is intended as information to assist the machine operator to perform daily maintenance tasks only, and does not replace the more thorough Preventive Maintenance and Inspection Schedule included in the Service and Maintenance Manual.

Other Publications Available:

Service and Maintenance Manual3121628
 Illustrated Parts Manual3121629

7.2 OPERATING SPECIFICATIONS AND PERFORMANCE DATA

Operating Specifications

Table 7-1. Operating Specifications

Travel Speed	3.0MPH (4.83 Km/hr.)
Maximum Travel Grade, stowed Position (Gradeability)	
2WD	30%
4WD	45%
Maximum Travel Grade, stowed Position (Side Slope)	5°
Turning Radius (Outside)	
2WS	19'8" (6.02 m)
4WS	11'7" (3.53 m)
Turning Radius (Inside)	
2WS	12'6" (3.8 m)
4WS	6' (1.83 m)
Overall Width	8'2" (2.48 m)
Tailswing	8'4" (2.56 m)
Ground Clearance	11" (28 cm)

SECTION 7 - GENERAL SPECIFICATIONS & OPERATOR MAINTENANCE

Table 7-1. Operating Specifications

Machine Height Stowed	9 ft. 9.5 in. (2.98 m)
Machine Length (Stowed)	
800A	36 ft.-9 in. (11.25 m)
800AJ	36 ft.-6 in. (11.13 m)
Wheel base	10 ft.-0 in. (3.05 m)
Boom Elevation - 800A	
Above Grade	+80 ft. (24.38 m)
Below Grade	-15 ft.-7 in. (4.75 m)
Boom Elevation - 800AJ	
Above Grade	+80 ft. (24.38 m)
Below Grade	-13 ft.-1 in. (3.99 m)
Max. Ground Bearing Pressure	76 psi. (5.3 kg/cm ²)
Max. Tire Load	17,755 lbs. (8054 kg)
Machine Weight approximately*	35,500 lb. (16,103 kg)
* Certain options or country standards can increase weight.	

Tires

Table 7-2. Tire Specifications

Size	Type	Ply Rating	Load Range	Pressure
15-625	pneumatic	16	H	95PSI (6.5 Bar)
15-625	foam-filled	16	H	N/A
18-625	foam-filled	16	H	N/A

Capacities

Table 7-3. Capacities

Fuel Tank	Approx. 39 gallons (147.6 liters)
Hydraulic Tank	Approx. 40 gallons (151.4 liters)
Hydraulic System (Including Tank)	77 Gal. (291.4 L)
Drive Hub	44 ounces (1.3 L)
Drive Brake	2.7 ounces (80 ml)
Engine Crankcase	
Deutz D2011L04	11 quarts (10.5 L)
Deutz TD 2.9L	2.4 Gallon (8.9 L) w/Filter
GM	4.5 qts. (4.25 L) w/Filter

Engine Data

Table 7-4. Deutz D2011L04 Specifications

Type	Liquid Cooled (Oil)
Fuel	Diesel
Oil Capacity	
Cooling System	5 Quarts (4.5 L)
Crankcase	11 Quarts (10.5 L) w/Filter
Total Capacity	16 Quarts (15 L)
Idle RPM	1000
Low RPM	1800
High RPM	2600
Alternator	55 Amp, belt drive
Fuel Consumption	0.88 GPH (3.33 lph)
Battery	1000 Cold Cranking Amps, 210 minutes Reserve Capacity, 12 VDC
Horsepower	61.6 @ 2600 RPM, full load

SECTION 7 - GENERAL SPECIFICATIONS & OPERATOR MAINTENANCE

Table 7-5. Deutz TD 2.9 Specifications

Fuel	Ultra Low Sulfur Diesel (15 ppm)
Output	67 hp (50 kW)
Torque	173 ft.lbs. (234 Nm) @ 1800rpm
Oil Capacity (Crankcase)	2.4 Gallon (8.9 L) w/Filter
Cooling System	3.3 Gallon (12.5 L)
Low RPM	1200 ± 50 rpm
High RPM	2600 ± 50 rpm
Alternator	95 Amp
Fuel Consumption	0.65 GPH (2.48 lph)

Table 7-6. GM 3.0L

Fuel	Gasoline or Gasoline/LP Gas
No. of Cylinders	4
BHP	
Gasoline	83 hp @ 3000 rpm
LP	75 hp @ 3000 rpm
Bore	4.0 in. (101.6 mm)
Stroke	3.6 in. (91.44 mm)
Displacement	181 cu.in. (3.0 L, 2966 cc)
Oil Capacity w/filter	4.5 qts. (4.25 L)
Minimum Oil Pressure	
at idle	6 psi (0.4 Bar) @ 1000 rpm
Hot	18 psi (1.2 Bar) @ 2000 rpm
Compression Ratio	9.2:1
Firing Order	1-3-4-2
Max. RPM	2800

Hydraulic Oil

Table 7-7. Hydraulic Oil

Hydraulic System Operating Temperature Range	S.A.E. Viscosity Grade
+0° to +180°F (-18° to +83°C)	10W
+0° to +210°F (-18° to +99°C)	10W-20, 10W30
+50° to +210°F (+10° to +99°C)	20W-20

NOTE: Hydraulic oils must have anti-wear qualities at least to API Service Classification GL-3, and sufficient chemical stability for mobile hydraulic system service. JLG Industries recommends Mobilfluid 424 hydraulic oil, which has an SAE viscosity index of 152.

NOTE: When temperatures remain consistently below 20 degrees F. (-7 degrees C.), JLG Industries recommends the use of Mobil DTE13.

Aside from JLG recommendations, it is not advisable to mix oils of different brands or types, as they may not contain the same required additives or be of comparable viscosities. If use of hydraulic oil other than Mobilfluid 424 is desired, contact JLG Industries for proper recommendations.

Table 7-8. Mobilfluid 424 Specs

SAE Grade	10W30
Gravity, API	29.0
Density, Lb/Gal. 60°F	7.35
Pour Point, Max	-46°F (-43°C)
Flash Point, Min.	442°F (228°C)
Viscosity	
Brookfield, cP at -18°C	2700
at 40°C	55 cSt
at 100°C	9.3 cSt
Viscosity Index	152

SECTION 7 - GENERAL SPECIFICATIONS & OPERATOR MAINTENANCE

Table 7-9. Mobil DTE 10 Excel 32 Specs

ISO Viscosity Grade	#32
Specific Gravity	0.877
Pour Point, Max	-40°F (-40°C)
Flash Point, Min.	330°F (166°C)
Viscosity	
at 40°C	33cSt
at 100°C	6.6cSt
at 100°F	169SUS
at 210°F	48SUS
cp at -20°F	6,200
Viscosity Index	140

Table 7-10. Mobil EAL 224H Specs

Type	Synthetic Biodegradable
ISO Viscosity Grade	32/46
Specific Gravity	.922
Pour Point, Max	-25°F (-32°C)
Flash Point, Min.	428°F (220°C)
Operating Temp.	0 to 180°F (-17 to 162°C)
Weight	7.64 lb. per gal. (0.9 kg per liter)
Viscosity	
at 40°C	37 cSt
at 100°C	8.4cSt
Viscosity Index	213
NOTE: Must be stored above 32°F (14°C)	

SECTION 7 - GENERAL SPECIFICATIONS & OPERATOR MAINTENANCE

Table 7-11. UCon Hydrolube HP-5046

Type	Synthetic Biodegradable
Specific Gravity	1.082
Pour Point, Max	-58°F (-50°C)
pH	9.1
Viscosity	
at 0°C (32°F)	340 cSt (1600SUS)
at 40°C (104°F)	46 cSt (215SUS)
at 65°C (150°F)	22 cSt (106SUS)
Viscosity Index	170

Table 7-12. Exxon Univis HVI 26 Specs

Specific Gravity	32.1
Pour Point	-76°F (-60°C)
Flash Point	217°F (103°C)
Viscosity	
at 40°C	25.8 cSt
at 100°C	9.3 cSt
Viscosity Index	376
NOTE: Mobil/Exxon recommends that this oil be checked on a yearly basis for viscosity.	

SECTION 7 - GENERAL SPECIFICATIONS & OPERATOR MAINTENANCE

Critical Stability Weights

WARNING

DO NOT REPLACE ITEMS CRITICAL TO STABILITY WITH ITEMS OF DIFFERENT WEIGHT OR SPECIFICATION (FOR EXAMPLE: BATTERIES, FILLED TIRES, COUNTER WEIGHT, ENGINE, AND PLATFORM) DO NOT MODIFY UNIT IN ANY WAY TO EFFECT STABILITY.

Table 7-13. Critical Stability Weights

COMPONENTS		LBS.	KG.
Tire & Wheel Size (Foam Filled Only)	15-625	544	247
	18-625	601	273
Engine	Deutz	534	242
	GM w/pumps	1030	468
Counterweight	Turntable	4805	2180
Wheel Hubs	Rear	218	99
	Front 2WD	210	99
	Front 4WD	218	99
Platform	6 FT. (1.83 M)	205	93
	8 FT. (2.44 M)	230	105

SECTION 7 - GENERAL SPECIFICATIONS & OPERATOR MAINTENANCE

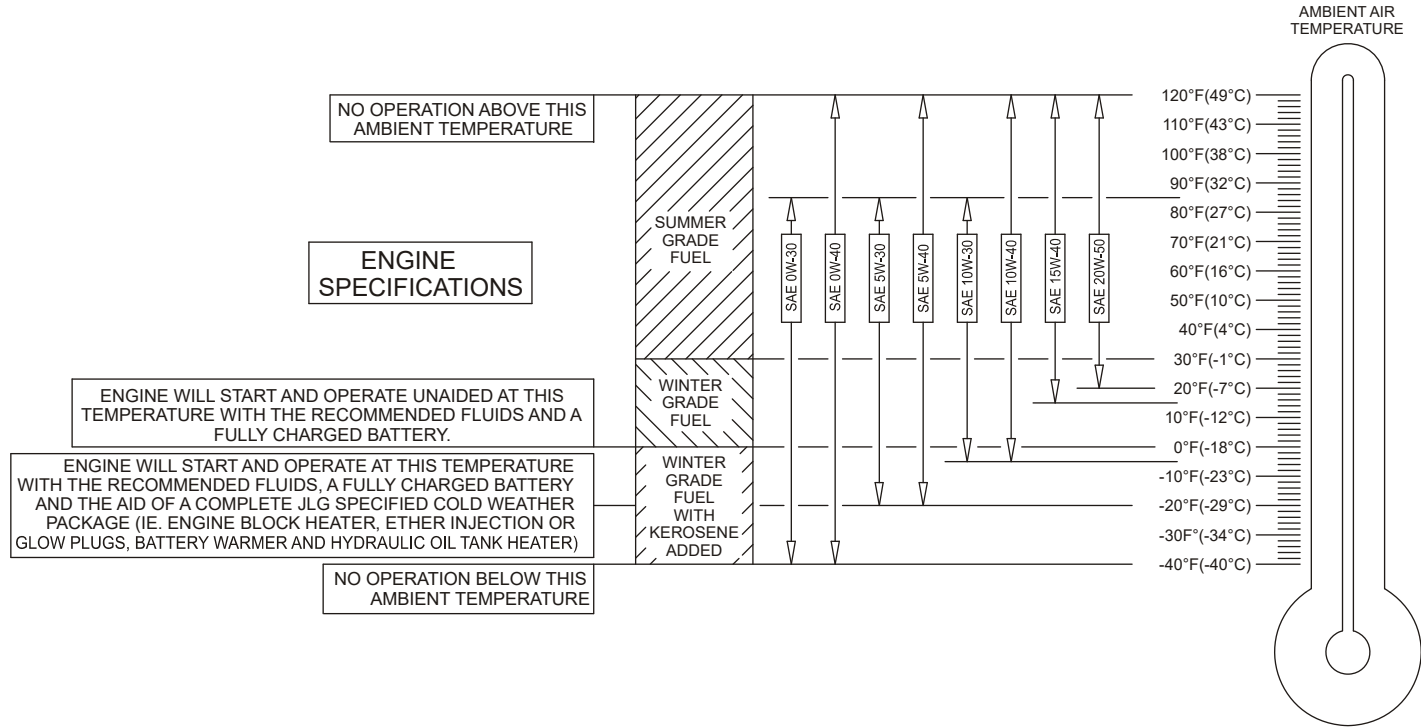

Figure 7-1. Engine Operating Temperature Specifications - Deutz - Sheet 1 of 2

SECTION 7 - GENERAL SPECIFICATIONS & OPERATOR MAINTENANCE

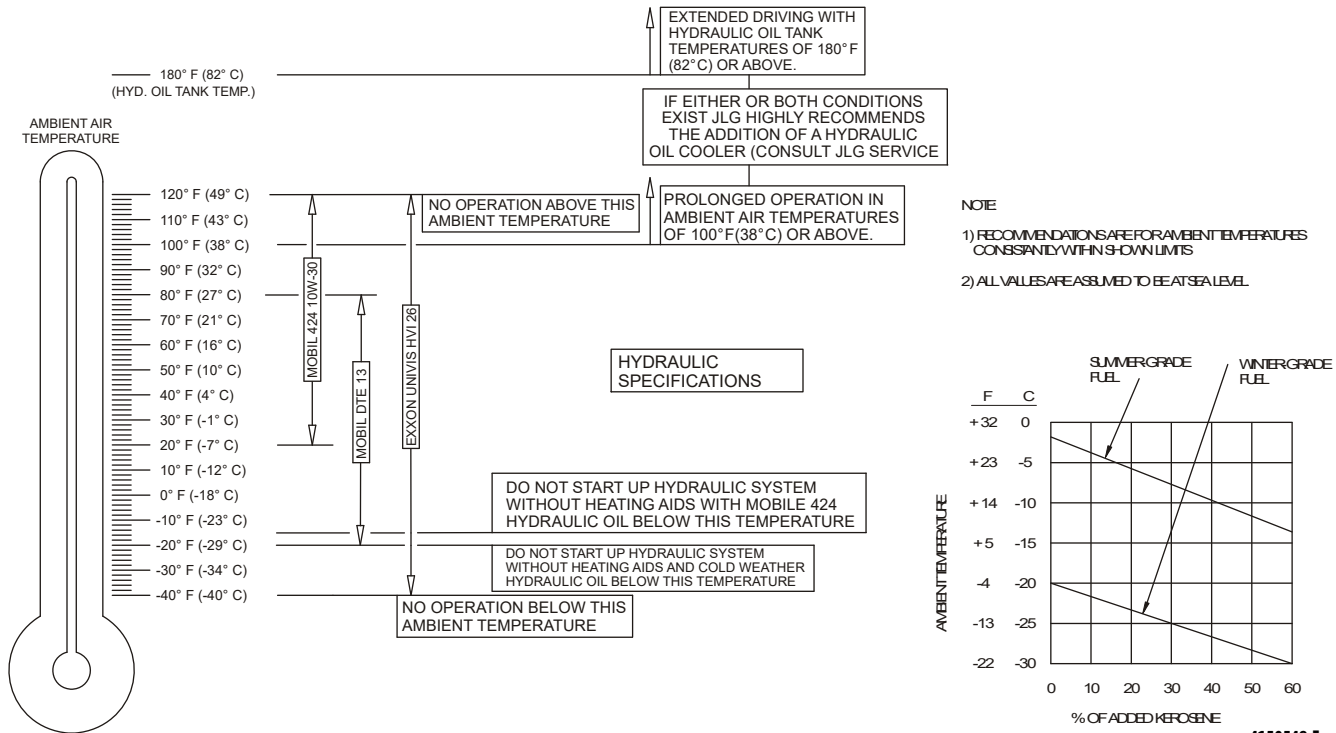

Figure 7-2. Engine Operating Temperature Specifications - Deutz - Sheet 2 of 2

SECTION 7 - GENERAL SPECIFICATIONS & OPERATOR MAINTENANCE

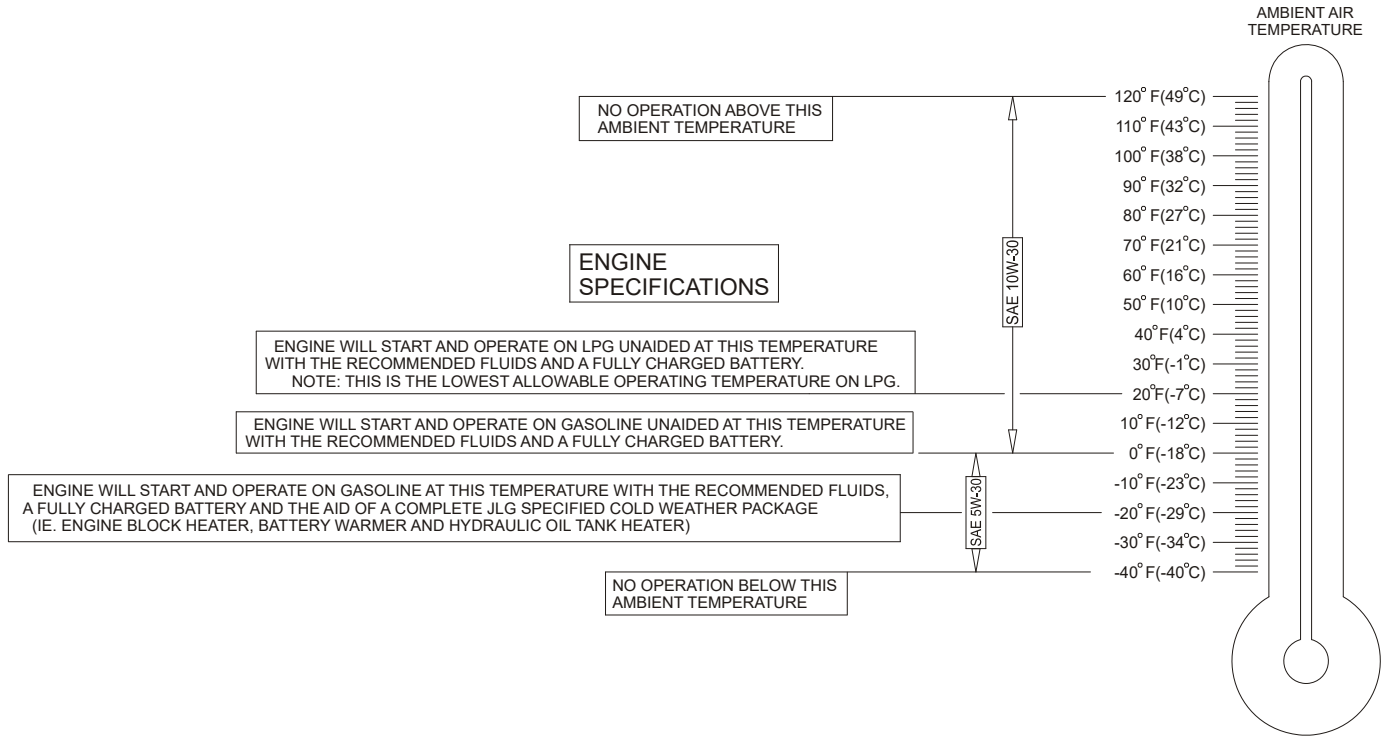
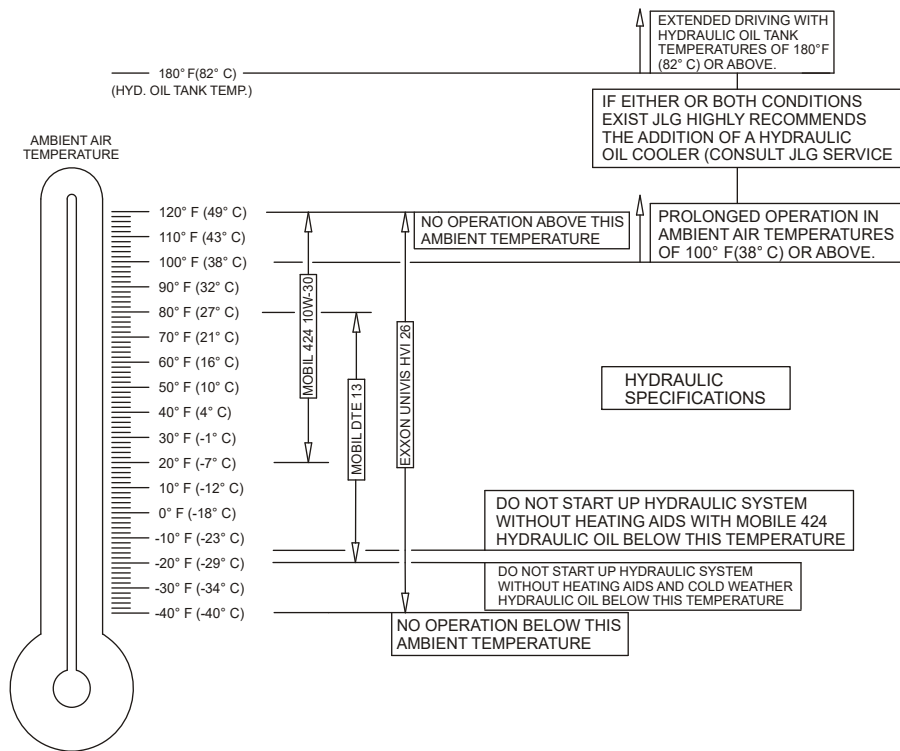

Figure 7-3. Engine Operating Temperature Specifications - GM - Sheet 1 of 2

SECTION 7 - GENERAL SPECIFICATIONS & OPERATOR MAINTENANCE



NOTE:

- 1) RECOMMENDATIONS ARE FOR AMBIENT TEMPERATURES CONSISTENTLY WITHIN SHOWN LIMITS
- 2) ALL VALUES ARE ASSUMED TO BE AT SEA LEVEL.

Figure 7-4. Engine Operating Temperature Specifications - GM - Sheet 2 of 2

4150548-E

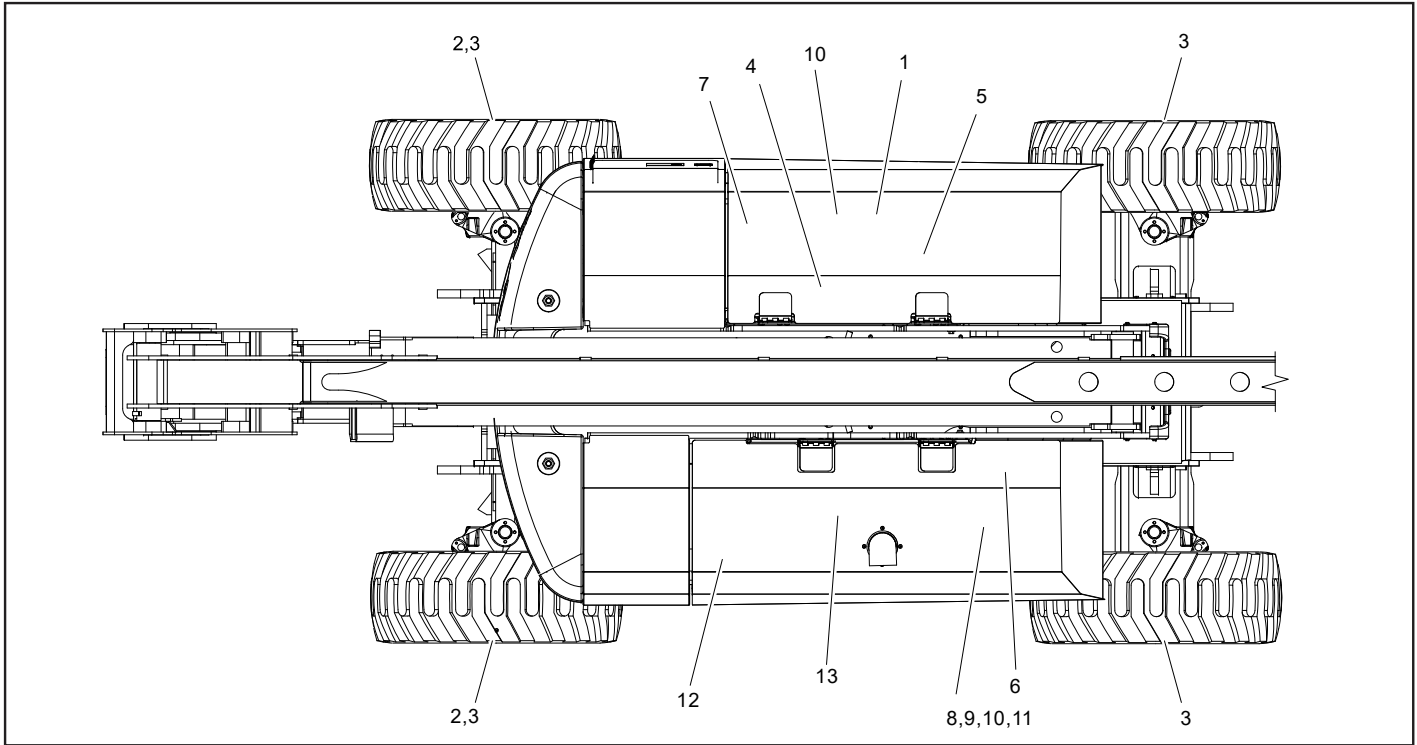

Figure 7-5. Maintenance and Lubrication Diagram

SECTION 7 - GENERAL SPECIFICATIONS & OPERATOR MAINTENANCE

7.3 MAINTENANCE AND LUBRICATION

NOTE: The following numbers correspond to those in Figure 7-5., Maintenance and Lubrication Diagram.

Table 7-14. Lubrication Specifications.

KEY	SPECIFICATIONS
MPG	Multipurpose Grease having a minimum dripping point of 350° F (177° C). Excellent water resistance and adhesive qualities, and being of extreme pressure type. (Timken OK 40 pounds minimum.)
EPGL	Extreme Pressure Gear Lube (oil) meeting API service classification GL-5 or MIL-Spec MIL-L-2105
HO	Hydraulic Oil. API service classification GL-3, e.g. Mobilfluid 424
EO	Engine (crankcase) Oil. Gas - API SF, SH, SG class, MIL-L-2104. Diesel - API CC/CD class, MIL-L-2104B/MIL-L-2104C
Super Lube®	Synthetic-Based Oil, Non-Flammable. Withstands temperatures within -45° to 450°F (-43° to 232° C). JLG P/N 3020042.

NOTICE

LUBRICATION INTERVALS ARE BASED ON MACHINE OPERATION UNDER NORMAL CONDITIONS. FOR MACHINES USED IN MULTI-SHIFT OPERATIONS AND/OR EXPOSED TO HOSTILE ENVIRONMENTS OR CONDITIONS, LUBRICATION FREQUENCIES MUST BE INCREASED ACCORDINGLY.

NOTE: It is recommended as a good practice to replace all filters at the same time.

1. Swing Bearing - Internal Ball Bearing



Lube Point(s) - 2 Grease Fittings
Capacity - A/R
Lube - MPG
Interval - Every 3 months or 150 hrs of operation
Comments - Remote Access

2. Wheel Bearings

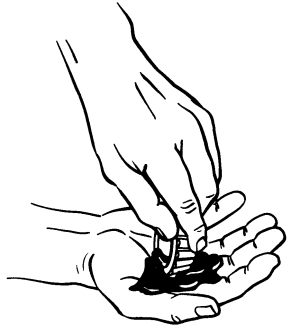

Lube Point(s) - Repack
Capacity - A/R
Lube - MPG
Interval - Every 2 years or 1200 hours of operation

3. Wheel Drive Hub

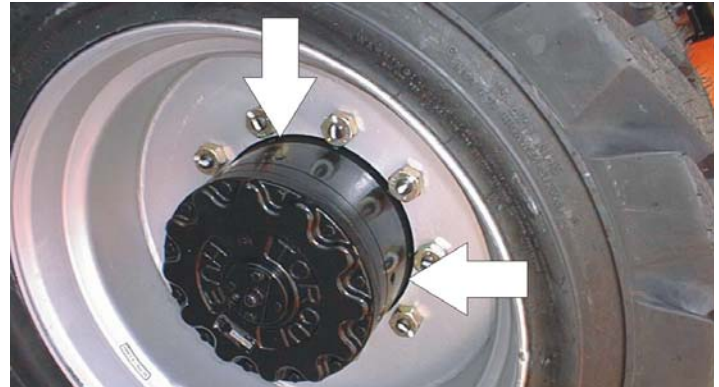

Lube Point(s) - Level/Fill Plug
Capacity - 17 oz. (0.5 L) - 1/2 Full
Lube - EPGL
Interval - Check level every 3 months or 150 hrs of operation;
change every 2 years or 1200 hours of operation
Comments - Place Fill port at 12 o'clock position and Check
port at 3 o'clock position. Pour lubricant into fill port until it
just starts to flow out of check port.

SECTION 7 - GENERAL SPECIFICATIONS & OPERATOR MAINTENANCE

4. Swing Drive Hub



Lube Point(s) - Level/Fill Plug

Capacity - 43 oz. (1.3 L)

Lube - 90w80 Gear Oil

Interval - Check level every 3 months or 150 hrs of operation;
change every 2 years or 1200 hours of operation

5. Hydraulic Return Filter

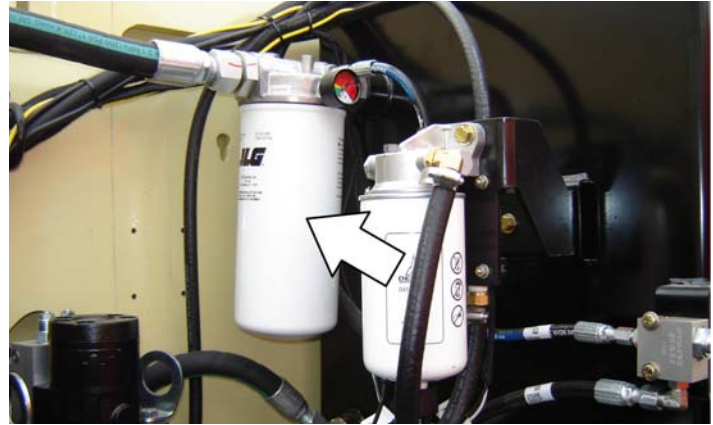

Interval - Change after first 50 hrs. and every 6 months or 300 hrs. thereafter or as indicated by Condition Indicator.

SECTION 7 - GENERAL SPECIFICATIONS & OPERATOR MAINTENANCE

6. Hydraulic Charge Filter



Interval - Change after first 50 hrs. and every 6 months or 300 hrs. thereafter or as indicated by Condition Indicator.

7. Hydraulic Tank



Lube Point(s) - Fill Cap

Capacity - 40 gallons (151 L) Tank; 77 gallons (291.4 L) System

Lube - HO

Interval - Check Level daily; Change every 2 years or 1200 hours of operation.

SECTION 7 - GENERAL SPECIFICATIONS & OPERATOR MAINTENANCE

8. Oil Change w/Filter - Deutz D2011

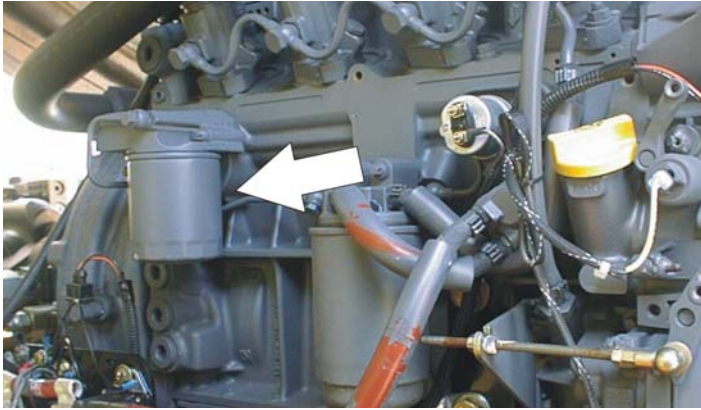

Lube Point(s) - Fill Cap/Spin-on Element
Capacity - 11 Quarts(10.5 L) Crankcase
Lube - EO
Interval - Every Year or 1200 hours of operation
Comments - Check level daily/Change in accordance with engine manual.

B. Oil Change w/Filter - Deutz TD2.9



Lube Point(s) - Fill Cap/Spin-on Element
Capacity - 9.6 Quarts (9.0 L)
Lube - EO
Interval - Every Year or 600 hours of operation
Comments - Check level daily/Change in accordance with engine manual.

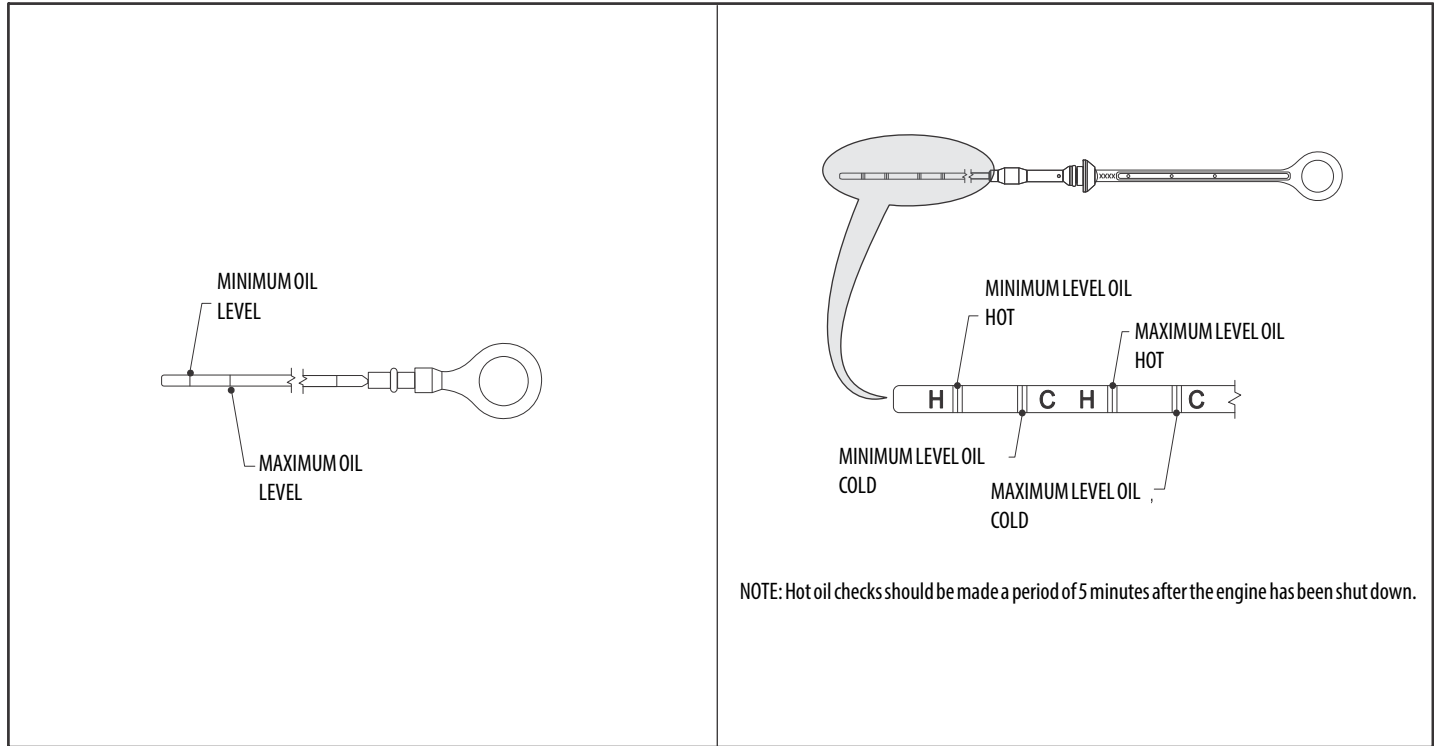
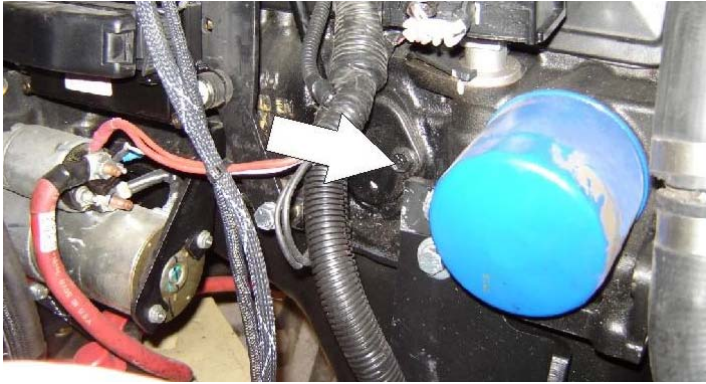

Figure 7-6. Deutz 2011 Engine Dipstick

SECTION 7 - GENERAL SPECIFICATIONS & OPERATOR MAINTENANCE

9. Oil Change w/Filter - GM



Lube Point(s) - Fill Cap/Spin-on Element
(JLG P/N 7027965)
Capacity - 4.5 qt. (4.25 L) w/filter
Lube - EO
Interval - 3 Months or 150 hours of operation
Comments - Check level daily/Change in accordance with engine manual.

10. Fuel Filter - Deutz D2011

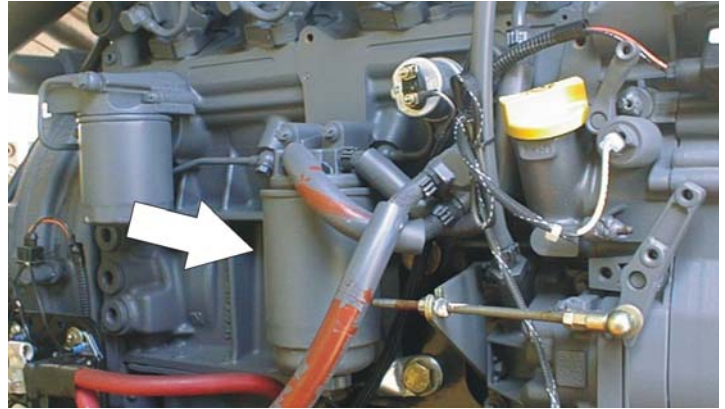

Lube Point(s) - Replaceable Element
Interval - Every Year or 600 hours of operation

SECTION 7 - GENERAL SPECIFICATIONS & OPERATOR MAINTENANCE

B. Fuel Filter - Deutz TD2.9 (On Hydraulic Tank)

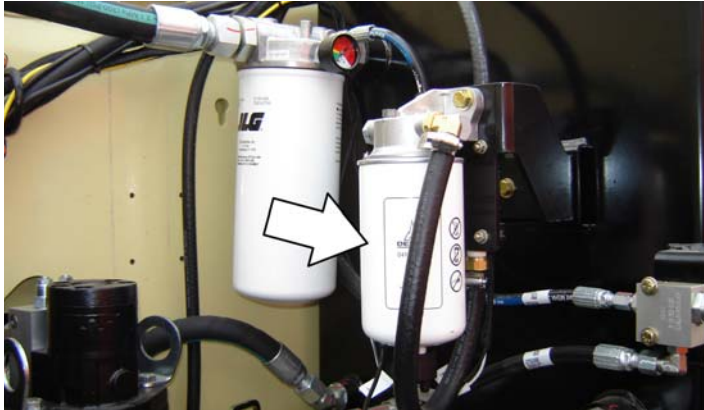

Lube Point(s) - Replaceable Element
Interval - Change in accordance with engine manual

C. Fuel Filter - Deutz TD2.9 (On Engine)



Lube Point(s) - Replaceable Element
Interval - Change in accordance with engine manual

11. Fuel Filter (Gasoline) - GM

Lube Point(s) - Replaceable Element
Interval - Every 6 months or 300 hours of operation

SECTION 7 - GENERAL SPECIFICATIONS & OPERATOR MAINTENANCE

12. Air Filter

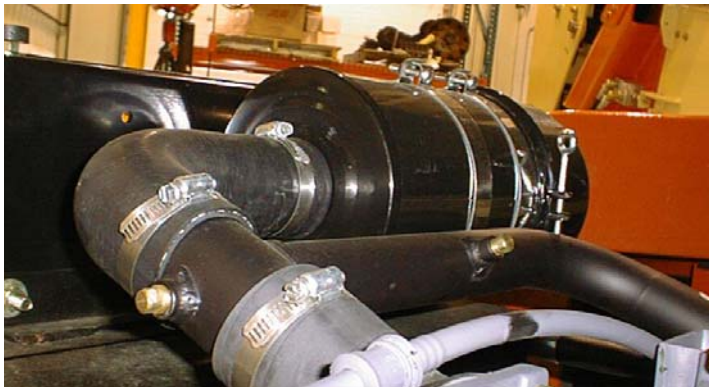

Lube Point(s) - Replaceable Element
Interval - Every 6 months or 300 hours of operation or as indicated by the condition indicator

B. Air Filter (Deutz TD 2.9)

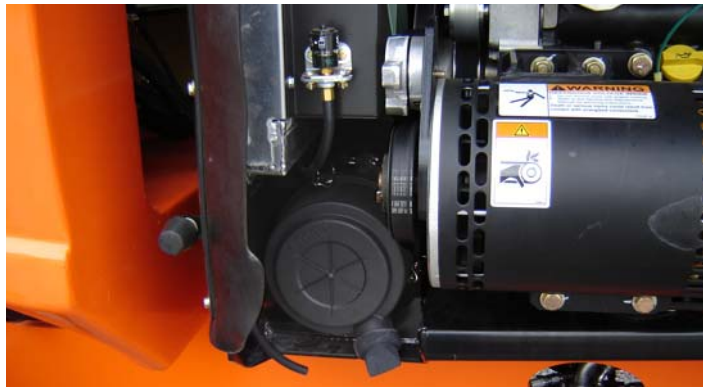

Lube Point(s) - Replaceable Element
Interval - Every 6 months or 300 hours of operation or as indicated by the condition indicator

13. Fuel Filter (Propane) - GM Engine

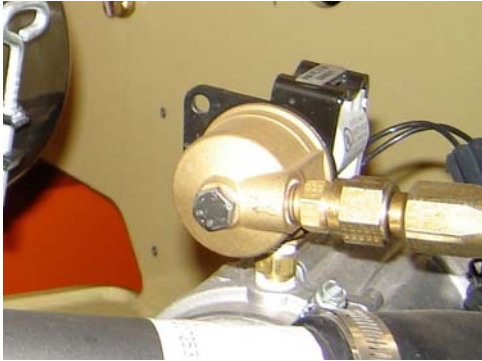

Interval - 3 Months or 150 hours of operation

Comments - Replace filter. Refer to Section 7.5, Propane Fuel Filter Replacement

7.4 TIRES & WHEELS

Tire Inflation

The air pressure for pneumatic tires must be equal to the air pressure that is stenciled on the side of the JLG product or rim decal for safe and proper operational characteristics.

Tire Damage

For pneumatic tires, JLG Industries, Inc. recommends that when any cut, rip, or tear is discovered that exposes sidewall or tread area cords in the tire, measures must be taken to remove the JLG product from service immediately. Arrangements must be made for replacement of the tire or tire assembly.

For polyurethane foam filled tires, JLG Industries, Inc. recommends that when any of the following are discovered, measures must be taken to remove the JLG product from service immediately and arrangements must be made for replacement of the tire or tire assembly.

- a smooth, even cut through the cord plies which exceeds 3 inches (7.5 cm) in total length
- any tears or rips (ragged edges) in the cord plies which exceeds 1 inch (2.5 cm) in any direction
- any punctures which exceed 1 inch in diameter

SECTION 7 - GENERAL SPECIFICATIONS & OPERATOR MAINTENANCE

- any damage to the bead area cords of the tire

If a tire is damaged but is within the above noted criteria, the tire must be inspected on a daily basis to insure the damage has not propagated beyond the allowable criteria.

Tire Replacement

JLG recommends a replacement tire be the same size, ply and brand as originally installed on the machine. Please refer to the JLG Parts Manual for the part number of the approved tires for a particular machine model. If not using a JLG approved replacement tire, we recommend that replacement tires have the following characteristics:

- Equal or greater ply/load rating and size of original
- Tire tread contact width equal or greater than original
- Wheel diameter, width, and offset dimensions equal to the original
- Approved for the application by the tire manufacturer (including inflation pressure and maximum tire load)

Unless specifically approved by JLG Industries Inc. do not replace a foam filled or ballast filled tire assembly with a pneumatic tire. When selecting and installing a replacement tire, ensure that all tires are inflated to the pressure recommended by JLG. Due to size variations between tire brands, both tires on the same axle should be the same.

Wheel Replacement

The rims installed on each product model have been designed for stability requirements which consist of track width, tire pressure, and load capacity. Size changes such as rim width, center piece location, larger or smaller diameter, etc., without written factory recommendations, may result in an unsafe condition regarding stability.

Wheel Installation

It is extremely important to apply and maintain proper wheel mounting torque.

⚠ WARNING

WHEEL NUTS MUST BE INSTALLED AND MAINTAINED AT THE PROPER TORQUE TO PREVENT LOOSE WHEELS, BROKEN STUDS, AND POSSIBLE DANGEROUS SEPARATION OF WHEEL FROM THE AXLE. BE SURE TO USE ONLY THE NUTS MATCHED TO THE CONE ANGLE OF THE WHEEL.

Tighten the lug nuts to the proper torque to prevent wheels from coming loose. Use a torque wrench to tighten the fasteners. If you do not have a torque wrench, tighten the fasteners with a lug wrench, then immediately have a service garage or dealer tighten the lug nuts to the proper torque. Over-tightening will result in breaking the studs or permanently deforming the mounting stud holes in the wheels. The proper procedure for attaching wheels is as follows:

1. Start all nuts by hand to prevent cross threading. DO NOT use a lubricant on threads or nuts.

2. Tighten nuts in the following sequence:

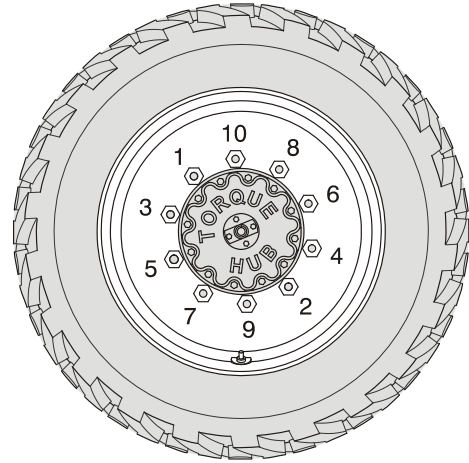

SECTION 7 - GENERAL SPECIFICATIONS & OPERATOR MAINTENANCE

3. The tightening of the nuts should be done in stages. Following the recommended sequence, tighten nuts per wheel torque chart.

Table 7-15. Wheel Torque Chart

TORQUE SEQUENCE		
1st Stage	2nd Stage	3rd Stage
70 ft. lbs. (95 Nm)	170 ft. lbs. (225 Nm)	300 ft. lbs. (405 Nm)

4. Wheel nuts should be torqued after first 50 hours of operation and after each wheel removal. Check torque every 3 months or 150 hours of operation.

7.5 PROPANE FUEL FILTER REPLACEMENT

Removal

1. Relieve the propane fuel system pressure. Refer to Propane Fuel System Pressure Relief.
2. Disconnect the negative battery cable.
3. Slowly loosen the Filter housing and remove it.
4. Pull the filter housing from the Electric lock off assembly.
5. Remove the filter from the housing.
6. Locate Filter magnet and remove it.
7. Remove and discard the housing seal.
8. If equipped, remove and discard the retaining bolt seal.
9. Remove and discard mounting plate to lock off O-ring seal.

Installation

NOTICE

BE SURE TO REINSTALL THE FILTER MAGNET INTO THE HOUSING BEFORE INSTALLING NEW SEAL

1. Install the mounting plate to lock off O-ring seal.
2. If equipped, install the retaining bolt seal.
3. Install the housing seal.
4. Drop the magnet into the bottom of the filter housing.
5. Install the filter into the housing.
6. If equipped, install the retaining bolt into the filter housing.
7. Install the filter up to the bottom of the electric lock off.
8. Tighten the filter bowl retainer to 106 in lbs (12 Nm).
9. Open manual shut-off valve. Start the vehicle and leak check the propane fuel system at each serviced fitting. Refer to Propane Fuel System Leak Test.

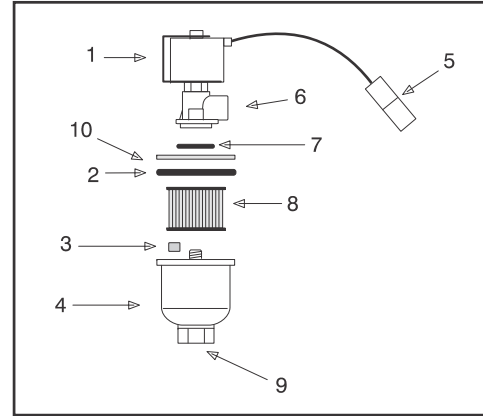

- | | |
|-------------------------------|----------------|
| 1. Electric Lock Off Solenoid | 6. Fuel Outlet |
| 2. Housing Seal | 7. O-ring |
| 3. Filter Magnet | 8. Filter |
| 4. Filter Housing | 9. Fuel Inlet |
| 5. Electrical Connector | 10. Ring |

Figure 7-7. Filter Lock Assembly

7.6 PROPANE FUEL SYSTEM PRESSURE RELIEF

CAUTION

THE PROPANE FUEL SYSTEM OPERATES AT PRESSURES UP TO 312 PSI (21.5 BAR). TO MINIMIZE THE RISK OF FIRE AND PERSONAL INJURY, RELIEVE THE PROPANE FUEL SYSTEM PRESSURE (WHERE APPLICABLE) BEFORE SERVICING THE PROPANE FUEL SYSTEM COMPONENTS.

To relieve propane fuel system pressure:

1. Close the manual shut-off valve on the propane fuel tank.
2. Start and run the vehicle until the engine stalls.
3. Turn the ignition switch OFF.

CAUTION

RESIDUAL VAPOR PRESSURE WILL BE PRESENT IN THE FUEL SYSTEM. ENSURE THE WORK AREA IS WELL VENTILATED BEFORE DISCONNECTING ANY FUEL LINE.

7.7 SUPPLEMENTAL INFORMATION

The following information is provided in accordance with the requirements of the European Machinery Directive 2006/42/EC and is only applicable to CE machines.

For electric powered machines, the equivalent continuous A-Weighted sound pressure level at the work platform is less than 70dB(A)

For combustion engine powered machines, guaranteed Sound Power Level (LWA) per European Directive 2000/14/EC (Noise Emission in the Environment by Equipment for Use Outdoors) based on test methods in accordance with Annex III, Part B, Method 1 and 0 of the directive, is 106 dB for machines equipped with Tier4i engines and 112 dB for machines equipped with T4F engines.

The vibration total value to which the hand-arm system is subjected does not exceed 2,5 m/s². The highest root mean square value of weighted acceleration to which the whole body is subjected does not exceed 0,5 m/s².

SECTION 8. INSPECTION AND REPAIR LOG

Machine Serial Number _____

Table 8-1. Inspection and Repair Log

Date	Comments



An Oshkosh Corporation Company

TRANSFER OF OWNERSHIP

To Product Owner:

If you now own but ARE NOT the original purchaser of the product covered by this manual, we would like to know who you are. For the purpose of receiving safety-related bulletins, it is very important to keep JLG Industries, Inc. updated with the current ownership of all JLG products. JLG maintains owner information for each JLG product and uses this information in cases where owner notification is necessary.

Please use this form to provide JLG with updated information with regard to the current ownership of JLG products. Please return completed form to the JLG Product Safety & Reliability Department via facsimile or mail to address as specified below.

Thank You,
Product Safety & Reliability Department
JLG Industries, Inc.
13224 Fountainhead Plaza
Hagerstown, MD 21742
USA
Telephone: +1-717-485-6591
Fax: +1-301-745-3713

NOTE: Leased or rented units should not be included on this form.

Mfg. Model: _____

Serial Number: _____

Previous Owner: _____

Address: _____

Country: _____ Telephone: (____) _____

Date of Transfer: _____

Current Owner: _____

Address: _____

Country: _____ Telephone: (____) _____

Who in your organization should we notify?

Name: _____

Title: _____



3121627



An Oshkosh Corporation Company

Corporate Office

JLG Industries, Inc.

1 JLG Drive

McConnellsburg, PA 17233-9533 USA

☎ (717) 485-5161 (Corporate)

☎ (877) 554-5438 (Customer Support)

☎ (717) 485-6417

Visit our website for JLG Worldwide Locations

www.jlg.com